

Owner Manual



WARNING

The engine exhaust from this product contains chemicals known to the State of California to cause cancer, birth defects or other reproductive harm.

Owner Manual

INTRODUCTION

Congratulations on your purchase of the HS550UTV-3/HS550UTV-4. This Owner's / Operator's manual will provide you information regarding safe operation, operational instructions, maintenance and care. Fully understanding this manual and following all of the instructions herein will provide the knowledge needed to have safe and enjoyable UTV operation.

For questions regarding this UTV, please call (972) 446-0760.

IMPORTANT SAFETY MESSAGE

- **READ THIS MANUAL TOGETHER WITH TIPS FOR THE UTV RIDER CAREFULLY AND COMPLETELY BEFORE OPERATING YOUR UTV. MAKE SURE YOU UNDERSTAND ALL INSTRUCTIONS.**
- **PAY CLOSE ATTENTION TO THE WARNING AND CAUTION LABELS ON THE UTV.**
- **NEVER OPERATE THE UTV WITHOUT PROPER TRAINING OR INSTRUCTION.**
- **THIS UTV, AND ANY OTHER UTV OVER 90cc, SHOULD NOT BE RIDDEN BY ANYONE UNDER 16 YEARS OF AGE.**

Owner Manual

IMPORTANT MANUAL INFORMATION

FAILURE TO FOLLOW THE WARNINGS CONTAINED IN THIS MANUAL CAN RESULT IN SERIOUS INJURY OR DEATH. Particularly important information is distinguished in this manual by the following notations:



The Safety Alert Symbol means **ATTENTION!**
YOUR SAFETY IS INVOLVED!



Failure to follow **WARNING** instructions could result in severe injury or death to the machine operator, bystander or a person inspecting or repairing the machine.



A CAUTION indicates special precautions that must be taken to avoid damage to the machine.

Owner Manual

NOTE:	A NOTE provides key information to make procedures easier or clearer.
--------------	-----------------------------------------------------------------------

IMPORTANT NOTICE

Curve speed must be smaller than 30km/h.

This UTV is designed and manufactured for **OFF - ROAD** use only. It is illegal and unsafe to operate this UTV on any public street, road or highway.

This UTV complies with all applicable **OFF - ROAD** noise level and spark arrester laws and regulations in effect at the time of manufacture.

Please check your local riding laws and regulations before operating this UTV.

When the temperature is below $-4^{\circ}\text{F}(-20^{\circ}\text{C})$, park the UTV in the place where the temperature is higher than $-4^{\circ}\text{F}(-20^{\circ}\text{C})$. Start the UTV has warmed up, the UTV can be started. Please see page 6-3 on the warming up process.

Follow the proper parking procedures when the temperature is higher than $100^{\circ}\text{F} (38^{\circ}\text{C})$: turn off the engine; make sure the radiator fan is on for 3 minutes before turning off the power switch.

Starting the UTV for the first time will take longer because the fuel will need reach the fuel injectors. To start the UTV the first time, hold the ignition key on at 5-second intervals. Allow the starter to rest 15 seconds between each start attempt.

Owner Manual

1	Warning and Specification Labels	1-1
2	Safety Information	2-1
3	Description and Vehicle Identification	3-1
	Identification Number Records	3-3
	Model Label	3-3
	Vehicle Identification Number	3-3
4	Control Functions	4-1
	Main Switch	4-1
	Indicator and Warning Lights	4-2
	Use of EPS system	4-4
	Speedometer Unit	4-5
	Odometer and Trip Meter Modes	4-6
	Fault code indicator	4-8
	Fuel level indicator	4-9

Accelerator Pedal	4-14
Brake Pedal	4-15
Drive Select Lever	4-16
Fuel Tank Cap	4-16
Seats	4-17
Moving Seat Forward and Backward.	4-18
Seat Belt	4-19
Cargo Bed	4-21
Front and Rear Shock Adjustment	4-22
Trailer Hitch Bracket	4-24
Auxiliary DC Jack	4-24

Owner Manual

Switches

4-10

5 Pre Operation Checks **5-1**

Brakes 5-2

Fuel 5-4

Gasoline 5-5

Engine/Reduction Gear box Oil 5-6

Coolant 5-6

Final Gear Oil 5-7

Differential Gear Oil 5-7

Adjustment of steering wheel 5-8

Throttle Pedal 5-8

Throttle Free-Play 5-9

Throttle Free-Play Inspection 5-9

Owner Manual

Throttle Free-Play Adjustment	5-10
Steering Wheel Inspection	5-10
Seat Belts	5-10
Fittings and Fasteners	5-11

Lights	5-11
Switches	5-11
Tires	5-12
How to Measure Tire Pressure	5-13
Tire Wear Limit	5-13

6 Operation **6-1**

Starting the Engine in Low

Temperatures	6-1	Warming Up	6-3
Starting the Engine	6-2	Drive Select Lever Operation and	
		Driving In Reverse	6-4
		Parking	6-6
		Parking on a Slope	6-7
		Vehicle Break-in Period	6-8
		Engine Break-In	6-9
		Accessories and Loading	6-10

Owner Manual

7 Driving Your Vehicle 7-1

Getting to Know Your Vehicle 7-1

Learning to Operate Your Vehicle

7-4

Turning your Vehicle 7-6

Braking 7-8

Going Uphill 7-8

Going Downhill 7-10

Crossing Through Shallow Lou Water

7-12

Rear Axle Differential Lock 7-15

Riding Over Rough Terrain 7-15

Riding in Brush or Wooded Areas 7-16

Encountering Obstacles on the

Trail 7-17

8

Adjustment 8-

Periodic Maintenance Chart for the **1**

Emission Control System 8-

General Maintenance and 3

Lubrication Chart 8-

4

Sundry Box Cover 8-

6

Engine Cover 8-

6

Owner Manual

		8-7	Periodic Maintenance and		
	EFI System Inspection	8-9		Axle Boots	8-20
	Engine Oil and Oil Filter Cartridge	8-10		Spark Plug Inspection	8-21
	To Change the Engine Oil	8-11		Inspection	8-22
	Final Gear Oil	8-14		Installation	8-22
24	Changing the Final Gear Oil	8-15		Cleaning the Air Filter Elements	8-
	Differential Gear Oil	8-16		Cleaning the Spark Arrester	8-27
	Coolant	8-19		Valve Clearance	8-29
				Front Brake Pad Check	8-29
				Rear Brake Pad Check	8-29
30				Checking the Brake Fluid Level	8-
				Brake Fluid Replacement	8-31
				Checking the Brake Pedal	8-32
				Cable Inspection and Lubrication	8-
33				Brake Pedal and Accelerator Pedal Lubrication	8-34
				Rear Knuckle Upper and Lower Pivot Lubrication	8-34
				Steering Shaft Lubrication	8-35
				Wheel Removal	8-37
			Wheel Installation		8-37

Owner Manual

	Battery	8-38	
	Battery Maintenance	8-40	
	Fuse Replacement	8-40	
	Replacing Headlight Bulb	8-42	
<hr/>			
	Tail/brake Light Bulb Replacement	8-45	
	Troubleshooting	8-47	
	Check and Solution to Common Problems in the Vehicle	8-48	
	Cleaning	9-1	
9	Storage	9-3	
			10 Cleaning and Storage 9-1 Specifications 10-1
11	Fault code of Electronic Injection System	11-1	
			12 USA EPA Emissions Limited Warranty
			12-1

Read and understand all of the labels on your vehicle. They contain important information for safe and proper operation of your vehicle. Never remove any labels from

your vehicle. If a label becomes difficult to read or comes off, a replacement label is available from your dealer.



Warning and Safety Labels 1-1

3.



2.



4.

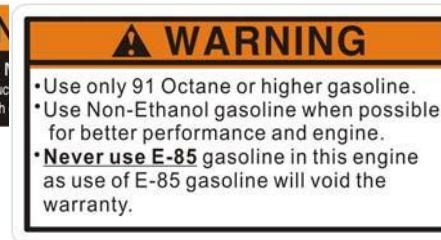

1-2 Warning and Safety Labels

5.

7.



6.



8.



Warning and Safety Labels 1-3

9.



10.



11.



12.



13.



1-4 Warning and Safety Labels

14.

15.

⚠ WARNING

Improper Operation Can Cause This Vehicle to Overturn and Lead to Serious Injury or Death.
 This vehicle handles differently than cars, trucks or other off road vehicles.
 In order to avoid overturns:

- avoid sharp turns.
- never turn while applying heavy throttle.
- turn speed less than 30km/h.
- never make abrupt steering maneuvers.
- operate at speeds appropriate for your skills, the conditions and the terrain.
- DO NOT do power slides, "donuts", jumps or other driving stunts.



⚠ WARNING

Instruction

preparing the battery for filling with electrolyte(acid).
 take off the rubber sealing cap and remove filling plugs.
 replace rubber cap with exhaust tube provided.

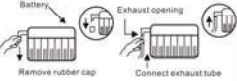

filling electrolyte(acid).
 fill battery with electrolyte(diluted sulphuric acid) with a specific gravity of: cool or temperate climate 1.270-1.280
 tropical climate 1.250-1.260
 the electrolyte temperature when filling must not be lower than 15°C or higher than 30°C.
 fill battery to upper level as indicated on the battery case.
 leave battery to stand for at least 30 minutes after filling.
 electrolyte level may fall during this period, refill to upper level before charging.

16.

⚠ WARNING

Improper vehicle use can result in SEVERE INJURY or DEATH

NEVER Operate:

- with more than one passenger.
- on hills steeper than 15 degrees.
- on public roads.
- on paved surfaces-pavement may seriously affect handling and control.

ALWAYS:

- keep hands and feet inside vehicle.
- reduce speed and use extra caution when carrying a passenger.
- operate slowly in reverse - avoid sharp turns or sudden braking.
- make sure passenger reads and understands all safety labels.
- watch for branches or other hazards that could enter vehicle.

LOCATE AND READ OWNER'S MANUAL. FOLLOW ALL INSTRUCTIONS AND WARNINGS.
 IF OWNER'S MANUAL IS MISSING, CONTACT YOUR DEALER FOR A REPLACEMENT.

ALWAYS USE AN APPROVED HELMET AND PROTECTIVE GEAR FOR OPERATOR AND PASSENGER



NEVER USE ON PUBLIC ROADS



NEVER USE WITH DRUGS OR ALCOHOL



 SAFETY INFORMATION

This off-highway utility vehicle handles differently from other vehicles including cars and UTVs. **SEVERE INJURY OR DEATH** can result if you do not follow these instructions:

- Read this manual and all labels carefully and follow the operating procedures described.
- This vehicle is designed to carry the driver and one passenger. **NEVER CARRY PASSENGERS IN THE CARGO BED.**
- Always be sure the driver and passenger are wearing seat belts.
- Never give a ride to a passenger who is too small to reach and hold the handgrip fixed before the seat.
- Always avoid operating the vehicle on any paved surfaces, including sidewalks, driveways, parking lots, and streets.
- Never operate this vehicle on any public street, road, or highway, even a dirt or gravel one.
- Never operate this vehicle without wearing an approved motorcycle helmet that fits properly. You should also wear eye protection (goggles or a face shield), gloves, over-the-ankle boots, long-sleeved shirt or jacket, and long pants.
- Never consume alcohol or drugs before or while operating this vehicle.
- Never operate at speeds too fast for your skills or the conditions. Always go at a speed that is proper for the terrain, visibility, operating conditions, and your experience.

2-2 Safety Information

- Never attempt jumps or other stunts.
- Always inspect your vehicle each time you use it to be sure it is in safe operating condition. Always follow the inspection and maintenance procedures and schedules described in this manual.
- Always keep both hands, arms, feet, and legs inside the vehicle at all times during operation. Keep your feet on the floorboard. Never hold onto the enclosure. Otherwise, your hand could be injured if it is caught between the enclosure and an obstacle outside the vehicle.
- Always keep both hands on the steering wheel when driving.
- Never wrap your thumbs and fingers around the steering wheel. This is particularly important when driving in rough terrain. The front wheels will move right and left as they respond to the terrain, and this movement will be felt in the steering wheel. A sudden jolt could wrench the steering wheel around, and your thumbs or fingers could be injured if they are in the way of the steering wheel spokes.
- Always go slowly and be extra careful when operating on unfamiliar terrain. Always be alert to changing terrain conditions when driving the vehicle.

Safety Information 2-3

- Never operate on excessively rough, slippery, or loose terrain until you have learned and practiced the skills necessary to control the vehicle on such terrain. Always be especially cautious on these kinds of terrain.
- Never turn at excessive speed. Practice turning at slow speeds before attempting to turn at faster speeds. Do not attempt turns on steep inclines.

- Never operate the vehicle on hills that are too steep for it or for your abilities. Go straight up and down hills where possible. Maximum slope angle: 15° .
- Never operate on hills that are slippery or ones where you will not be able to see far enough ahead of you. Never go over the top of a hill at speed if you cannot see what is on other side.
- Always follow proper procedures for going uphill. If you lose control and cannot continue up a hill, back down the hill with the engine in reverse gear. Use engine braking to help you go slowly. If necessary, use the brakes gradually to help you go slowly.
- Always check terrain before going down hills. Go as slowly as possible. Never go down a hill at high speed.
- Always check for obstacles before operating in a new area.
- Never operate the vehicle in fast flowing water or water deeper than the floorboards on this model. Remember that wet brakes may have reduced stopping ability. Test your brakes

after leaving water. If necessary, apply the brake several times to let friction dry out the linings.

- Always be sure there are no obstacles or people behind you when you operate in reverse. When it is safe to proceed in reverse, go slowly.
- Do not brake abruptly when carrying loads in the cargo bed.
- Always use the size and type of tires specified in this manual.
- Always maintain proper tire pressure as described in this manual.
- Never exceed the stated load capacity. Cargo should be as far forward in the bed as possible, and distributed evenly from side to side. Be sure cargo is secured so that it cannot move around during operation. Reduce speed and follow instructions in this manual for carrying cargo or pulling a trailer. Allow greater distance for braking.

2-4 Safety Information

 **WARNING**

POTENTIAL HAZARD

Improper handling of gasoline.

WHAT CAN HAPPEN

Gasoline can catch fire and you could be burned.

HOW TO AVOID THE HAZARD

Always turn off the engine when refueling. Do not refuel right after the engine has been running and is still very hot. Do not spill gasoline on the engine or exhaust pipe (or muffler) when refueling. Never refuel while smoking, or while in the vicinity of sparks, open flames, or other sources of ignition such as the pilot light of water heaters and clothes dryers. When transporting the vehicle in another vehicle, be sure it is kept in an upright position. Otherwise, fuel may leak out of the fuel tank.

WHAT CAN HAPPEN

Gasoline is poisonous and can cause injuries.

HOW TO AVOID THE HAZARD

If you should swallow some gasoline or inhale a lot of gasoline vapor, or get some gasoline in your eyes, see your doctor immediately. If gasoline spills on your skin, wash with soap and water. If gasoline spills on your clothing, change your clothes.

⚠ WARNING

POTENTIAL HAZARD

Starting or running the engine in a closed area.

WHAT CAN HAPPEN

Exhaust fumes are poisonous and may cause loss of consciousness and death within a short time.

HOW TO AVOID THE HAZARD

Always operate your vehicle in an area with adequate ventilation.

3-1 Description and Vehicle Identification

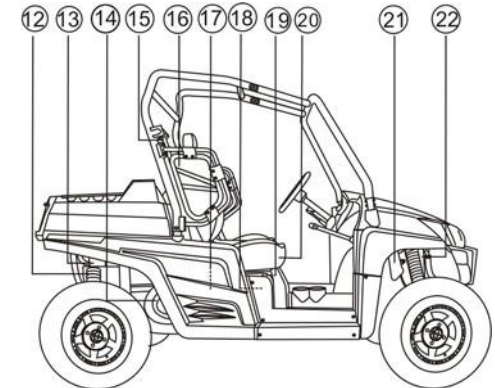
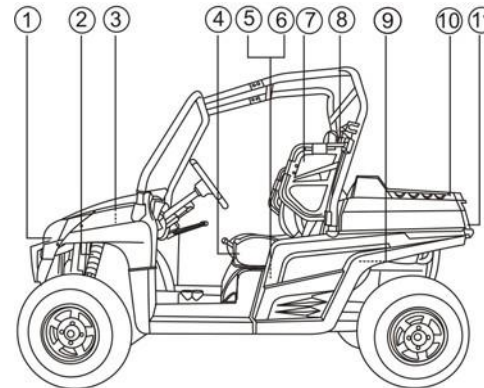

- | | |
|-----------------------------------|-------------------------------------|
| 1. Headlights | 12. Rear shock absorber assembly |
| 2. Front shock absorber assembly | 13. Spark arrester |
| 3. Brake fluid reservoir | 14. CVT-belt case |
| 4. Driver seat | 15. Passenger seat belt |
| 5. Battery | 16. Right shoulder protection plate |
| 6. Fuses | 17. Spark plug |
| 7. Left shoulder protection plate | 18. Oil filter cartridge |
| 8. Driver seat belt | 19. Fuel tank cap |
| 9. Air filter element | 20. Passenger seat |
| 10. Cargo bed | 21. Coolant reservoir |
| 11. Tail/brake lights | 22. Radiator cap |

Description and Vehicle Identification 3-2

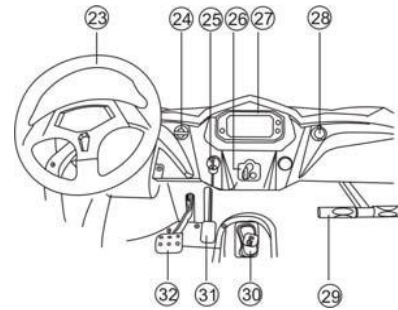

- 23. Steering wheel
- 24. Light switch
- 25. Ignition switch
- 26. On-Command four-wheel-drive and differential lock switches
- 28. Auxiliary DC jack

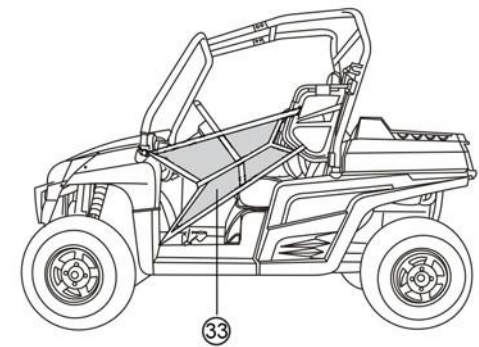

- 27. Multi-function display gauge

-
- 29. Passenger handrail
 - 30. Drive select lever
 - 31. Accelerator pedal 32. Brake pedal 33. Cab nets.

NOTE: _____ The vehicle you have purchased may differ slightly from

those in the figures of this manual.

3-3 Description and Vehicle Identification

Identification Number Records

Record the
Vehicle
Identification
Number and
model label

WARNING

To protect drivers and passengers' arm, leg and feet, make sure the cab nets is in function before driving.

information in
spaces provided
for assistance
when ordering
spare parts from
a dealer or for
reference in

case the vehicle
is stolen.

1.VEHICLE
IDENTIFICATIO
N NUMBER:

NOTE:_____ The vehicle identification number is used to
identify your vehicle.

2.MODEL
LABEL
INFORMATION

Vehicle Identification Number

The Vehicle Identification Number is stamped into the frame.

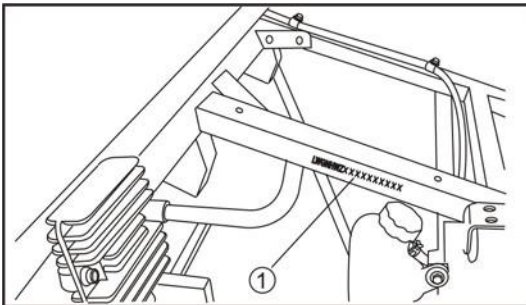

1. Vehicle identification number

CONTROL FUNCTIONS

Functions of the respective switch positions are as follows:

ON:

All electrical circuits are supplied with power, and the headlights and taillights illuminate when the light switch is on. **OFF:**

All electrical circuits are switched off. The key can be removed in this position. **START:**

Main Switch

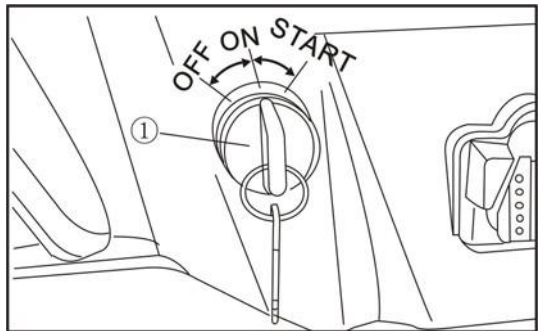

The electric starter is engaged by turning and

Release the key when the engine starts.

1. Ignition Switch holding the key in this position.

CAUTION:

- Do not operate the electric starter continuously for more than 5 seconds, or starter damage could occur. Wait at least 5 seconds between each operation of the electric starter to let it cool.
- Do not turn the key to the "START" position with the engine running, or damage to the electric starter can result.
- See starting instructions prior to starting the engine. (See pages 6-1—6-3 for details.)

Indicator and Warning Lights

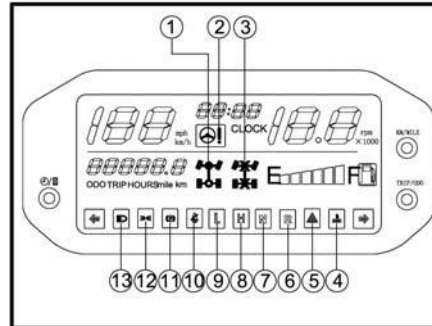

1. Four-wheel locked showing light
2. Fault indicator light of EPS system
3. differential gear lock indicator
4. Coolant temperature warning light
5. Emergency indicator
6. Reverse indicator light "R"
7. Neutral indicator light "N"
8. High-range indicator light "H"
9. Low-range indicator light "L"

10. Safety belt alarm
11. Mechanical parking brake indicator light "P"
12. Position indicator
13. Far light indicator

Low-Range Indicator Light "L"

This indicator light comes on when the drive select lever is in the "L" position.

Mechanical Parking Brake Indicator Light "P"

This indicator light comes on when the mechanical parking brake is applied.

High-Range Indicator Light "H"

This indicator light comes on when the drive select lever is in the "H" position.

Neutral Indicator Light “N”

This indicator light comes on when the drive select lever is in the “N” position.

Reverse Indicator Light “R”

This indicator light comes on when the drive select lever is in the “R” reverse position.

**Coolant Temperature Warning Light “

When the coolant temperature reaches a specified level, this light comes on to warn that the coolant temperature is too hot. If the light comes on during operation, stop the engine as soon as it is safe to do so and allow the engine to cool down for about 15 minutes.****CAUTION:**

- The engine may overheat if the vehicle is overloaded. If this happens, reduce the load to specification.
- After restarting, make sure that the light is out. Continuous use while the light is on may cause damage to the engine.

High beam indicator

The light being on means headlight is at high beam mode.

Position light indicator

The light being on means that the position light fixed in the front headlight has been turned on.

Emergency indicator “”

The light being on means emergency lamp is on.

Use of EPS system

Meter is an important part of UTV.

Meter works together with EPS system and monitors working condition of EPS system. Fault can be displayed by fault indicator light and fault indicator of EPS system, so the driver can acknowledge fault of EPS in time and take some measures to keep himself/herself safe.

When fault occurs on EPS system, fault indicator light will be lit up. At the same time, fault indicator of EPS system will display the fault code for maintenance.

- Open main switch of UTV, and EPS system will automatically enter into working state.
- Check the meter. If fault indicator light of EPS system does not be lit, ECU can be for regular use.
- If fault indicator light of EPS system is lit, that means EPS system find out some fault during ECU self-checking process, then you should consult your local dealer for maintenance in time.

-
- 7. Left turn indicator light
 - 8. Clock/Hour/ fault code reset button 

Speedometer Unit

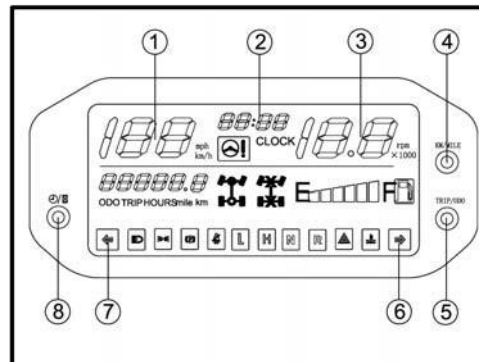

- 1. Speed indicator
- 2. Clock/Hour/ fault code meter
- 3. RPM indicator
- 4. Metric/mile button
- 5. "TRIP/ODO" button
- 6. Right turn indicator light

Speedometer unit functions:

- a speedometer (which shows the speed)
- an odometer (which shows the total distance covered)
- a tripometer (which can be cleared and then show any new distances traveled)
- an RPM indicator (which shows the revolutions per minute of the engine)
- a clock
- an EFI fault code indicator (which shows the fault code for problems with the EFI)

Odometer and trip meter modes

On the display panel there are two large buttons, one located on the left side and one on the right side. Quickly pressing the button on the left side toggles the display from the odometer, to the tripometer, and then to the hours meter; then it starts the cycle over.

The odometer displays the total distance traveled by the UTV. The tripometer records distances for a specific trip and can record distances from 0 through 999.9 miles. To reset a trip meter, select it by pressing the left button, Press left button to switch to small mileage (Trip), press the right button for a long time to reset. The tripometer can be used to estimate the distance that can be traveled with a full tank of fuel. This information will enable you to judge the fuel consumption.

To change the display from miles per hour to kilometers per hour press the right side button on the display. This will also change the displayed mileage from miles to kilometers.

Clock time adjustment

Press the left button and hold for three seconds and the clock goes into the hour 'set' mode.

1. Press the right button to set the hour.
2. Press the left button again and the clock goes into the minute 'set' mode.
3. Press the right button to set the minutes.
4. Press the left button again and the clock will exit the 'set' mode.

Four-wheel drive indicator “4WD”

There are two 4WD indicators on the display panel. The left 4WD indicator has a blinking circle on the front axle when the grey and yellow 4WD selector buttons are pressed in indicating the “4WD” function has been activated. This position also indicates that the 4WD is NOT locked. This allows the wheels on the left and right sides to rotate at different speeds to accommodate turning.

Differential gear lock indicator

The right 4WD symbol will show an ‘X’ over the center of the front axle when the lever is moved to the right and the yellow differential gear lock button is set to out position, which means the differential is not operational and is locked. When

riding an UTV on muddy and slippery roads or when climbing a steep hill, make sure the 4WD lock indicator is on. When riding on a flat road at a comparatively high speed, adjust the settings to “2WD/UNLOCK” and there are no symbols in either of the 4WD indicators.

Riding an UTV while the differential is functioning and is NOT locked, may improve the stability and safety of the UTV operation.

CAUTION:

When the selector is set to 4WD, the right 4WD symbol front axle will have an ‘X’ in the middle . When riding on good surfaces you should unlock the differential and press in the yellow and

the gray buttons to the 2WD unlocked position. There should be no symbols showing in either the left or right 4WD indicators.

CAUTION:

If the display indicators flash or the speedometer does not show the speed while the UTV is in motion, Ask a dealer to check the speed sensor and circuits.

Fault code indicator

When the EFI encounters faults, the ECU will send the fault code to the instrument display, and it will flash on the clock.

If there are more than one fault code, they will be shown in rolling sequence. When fault codes are present, in order to see the time press the clock button, the time will be

shown. Then after five seconds, the fault code returns again. Only after the fault is fixed, will the time show automatically. The description for the fault codes are shown in Chapter 11 of this manual.

Fuel level indicator

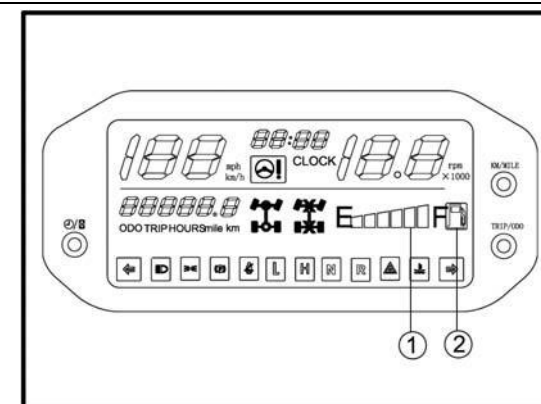

The fuel level display will indicate the fuel volume. When the fuel is getting low the fuel pump symbol will flash.

1. Fuel level indicator
2. Fuel level warning indicator



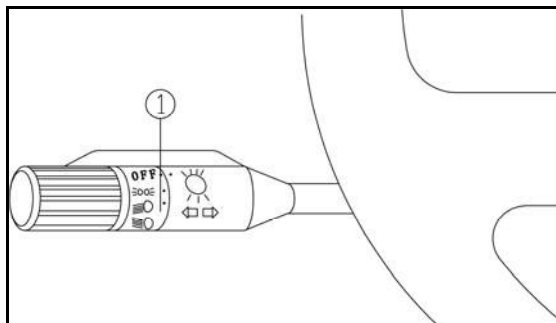

Switches



1. Light switch “OFF/ / ”

Light Switch “OFF/ / ”

Set the switch to “  ” to turn on the low beam and the taillights.

Set the switch to “  ” to turn on the high beam and the taillights.

Set the switch to “OFF” to turn off all lights.

CAUTION:

Do not use the headlights with the engine turned off for an extended period of time. The battery may discharge to the point that the starter motor will not operate properly. If this should happen, remove the battery and recharge it.

On-Command Four-Wheel-Drive and Differential

with an On command four-wheel-drive switch "2WD"/"4WD" and a

Gear Lock Switches

differential gear lock switch "2WD"/UNLOCK".

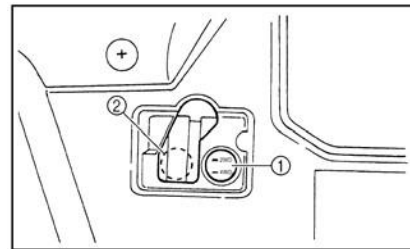

1. On-Command four-wheel-drive switch "2WD"/"4WD"
2. Differential gear lock switch "UNLOCK"/"2WD"

Select the appropriate drive according to terrain and the conditions.

- Only rear wheels have differential lock mechanism.
- Two-wheel drive, Power is supplied to the rear wheels only. With the rear wheels differential gear locked, the two rear wheels turn at the same speed regardless of traction.
- Four-wheel drive, Power is supplied to the rear and front wheels. With the rear wheels' differential gear locked, the two rear wheels turn at the same speed regardless of traction.
- Two-wheel drive with differential gear, Power is supplied to the rear wheels only. With the differential gear of rear wheels unlocked, the two rear wheels can turn at different speed.

This vehicle is equipped

⚠ WARNING

4-14 Control Functions

POTENTIAL HAZARD

Changing from 2WD to 4WD or from 2WD to 2WD-Differential UNLOCK, or vice-versa while the vehicle is moving.

WHAT CAN HAPPEN

The vehicle handles differently in 4WD than in 2WD and in 2WD- Differential UNLOCK in some circumstances. Changing from 2WD to 4WD or from 2WD to 2WD-Differential UNLOCK, or vice-versa while moving may cause the vehicle to unexpectedly handle differently. This could distract the operator and increase the risk of losing control and an accident.

HOW TO AVOID THE HAZARD

Always stop the vehicle before changing from 2WD to 4WD or from 2WD to 2WD-Differential UNLOCK, or vice-versa.

On-Command Four-Wheel-Drive Switch “2WD/4WD”

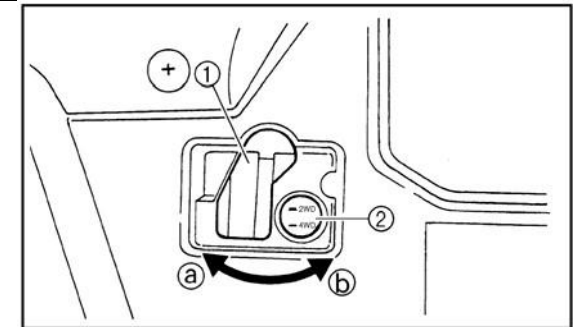

1. Select lever
2. On-Command four-wheel-drive switch “2WD/4WD”

To change from 2WD to 4WD stop the vehicle, be sure the select lever is set to position (a), and then set the switch to “4WD”. When the vehicle is in 4WD, the 4WD indicator will come on in the multi-function display.

To change from 4WD to 2WD stop the vehicle, and then set the switch to “2WD”. The 4WD indicator will go out in the multi-function display.

On-Command Differential Gear Lock Switch “2WD/UNLOCK”

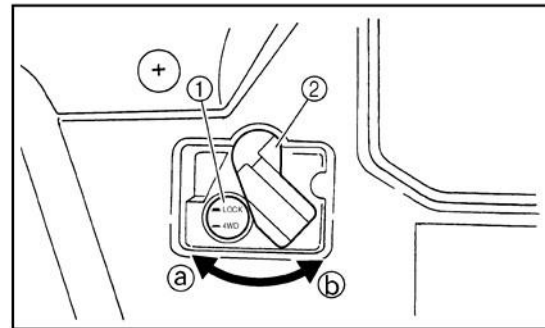

1. On-Command differential lock switch “2WD/UNLOCK”
2. Select lever

To unlock the differential gear in 2WD
Stop the vehicle, make sure the
On-Command four-wheel-drive switch is set
to “2WD”, move the select lever to position

②, and then set the switch to “UNLOCK”. the
differential gear is unlocked, the differential
gear lock indicator light will go out.
At this time, with rear differential lock on the
rear bridge unlocked, the rear differential
starts to work.

⚠ WARNING

POTENTIAL HAZARD

**Riding too fast while the vehicle is in
4WD-LOCK.**

WHAT CAN HAPPEN

**All wheels turn at the same speed when
the differential is locked, so it takes
more effort to turn the vehicle. The
amount of effort required is greater the**

**faster you go. You may lose control and
have an accident if you cannot make a**

sharp enough turn for the speed you are traveling.

HOW TO AVOID THE HAZARD Always ride at a slow speed when the vehicle is in 4WD-LOCK, and allow extra time and distance for maneuvers.

Accelerator Pedal

Press the accelerator pedal down to increase engine speed. Spring pressure returns the pedal to the rest position when released. Always check that the accelerator pedal returns normally before starting the engine.

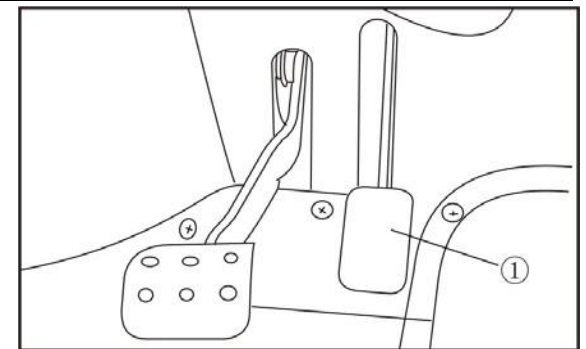

1. Accelerator pedal

Before starting the engine, check the accelerator pedal to be sure it is operating smoothly. Make sure the accelerator pedal fully returns to the idle position as soon as it is released.

⚠ WARNING

POTENTIAL HAZARD

Malfunction of the accelerator pedal.

WHAT CAN HAPPEN

The accelerator pedal could be hard to operate, making it difficult to speed up or slow down when you need to. This could cause an accident.

HOW TO AVOID THE HAZARD

Check the operation of the accelerator pedal before you start the engine. If it does not work smoothly, check for the cause. Correct the problem before operating the vehicle. Consult a dealer if you can't find or solve the problem yourself.

Brake Pedal

Press the brake pedal to slow or stop the vehicle.

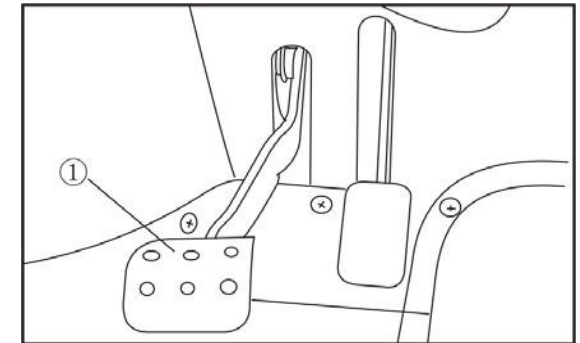

1. Brake pedal

Drive Select Lever

The drive select lever is used to shift the vehicle into low, high, neutral and reverse counter clockwise.

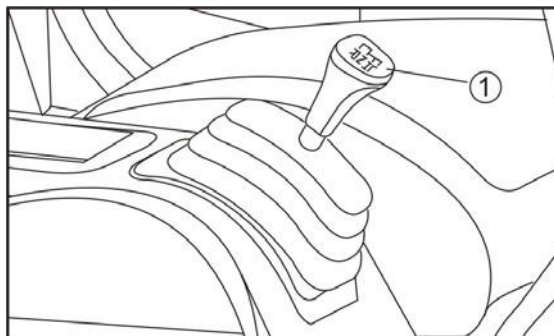

positions. (Refer to pages 6-4—6-5 for the drive select lever operation.)

Fuel Tank Cap

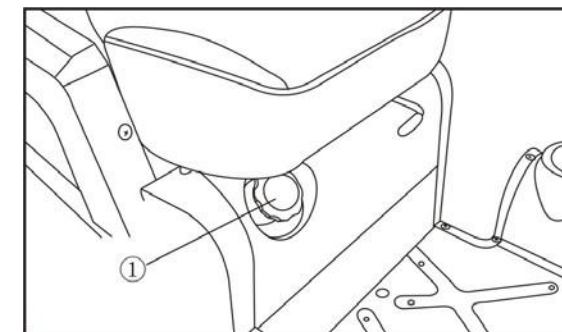

1. Fuel tank cap

1. Drive select lever

Seats

To
remov
e a
seat,
Remo
ve
bolts
M6
with
socket
wrenc

h, and then remove
the seat. Installation
is the reverse of
removal.

4-20 Control Functions

ger seat

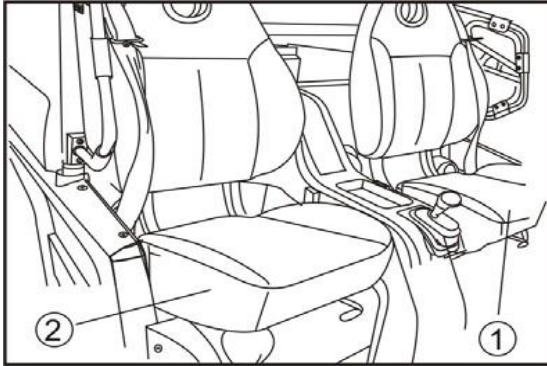

1
·
D
r
i
v
e
r
s
e
a
t
2
·
P
a
s
s
e
n

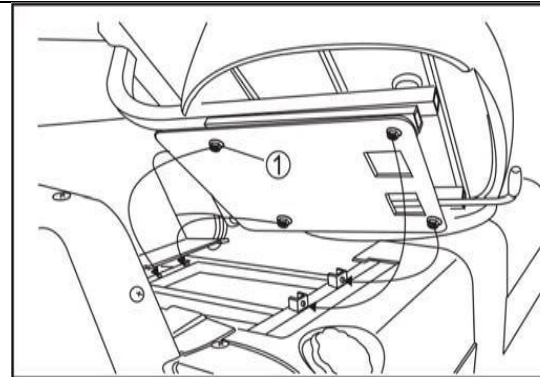

1.Bolt (4×M6)

CAUTION:

To install the seat, Adjust the four bolts M6 cooperatively to ensure the seat can move forward and backward normally. Improper installation can result in seat rail blocked and failure to move the seat back and forth.

Moving Seat Forward and Backward.

⚠ WARNING

POTENTIAL HAZARD**A loose seat.****WHAT CAN HAPPEN****The operator could lose control or the operator or passenger could fall if the seat is loose during operation.****HOW TO AVOID THE HAZARD****Make sure the seat is mounted firmly.**

The seat can be moved forward and backward to fit the height of different drivers. Pull up the handle, then you can move the seat forward and backward.

Seat Belt

This vehicle is equipped with three-point seat belts for both the operator and passenger. Always wear the seat belt while riding in the vehicle.

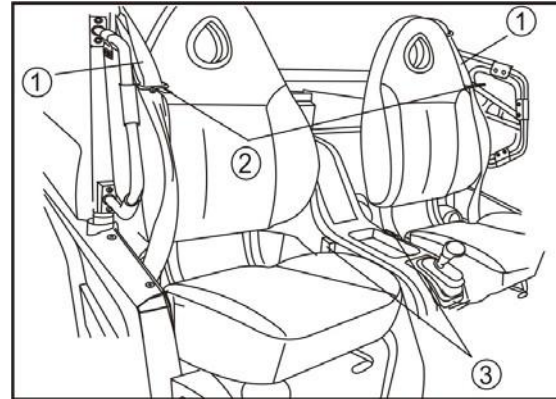

1. Seat belt (x2) 2. Latch plate (x2)
3. Buckle (x2)

To wear the seat belt properly, do the following:

1. Hold the latch plate as you pull the belt across your lap and chest. Make sure the belt is not twisted and is not caught on any portion of the vehicle, your clothing, or any equipment you are carrying.
2. Push the latch plate into the buckle until it clicks. Pull up on the latch plate to make sure it is secure.

1. Seat handle

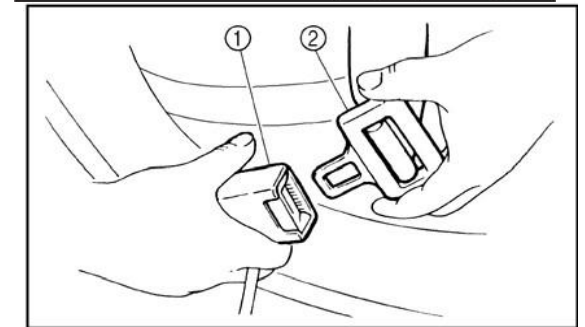
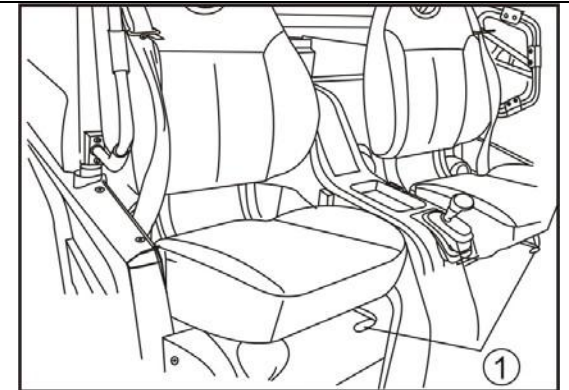

1. Buckle 2. Latch plate

3. Put the lap portion of the belt low on your hips. Push down on the buckle end of the belt as you pull up on the shoulder part so the belt is snug across your hips.
4. Position the shoulder belt over your shoulder and across your chest. The shoulder belt should fit against your chest. If it is loose, pull the belt out all the way and then let it retract.

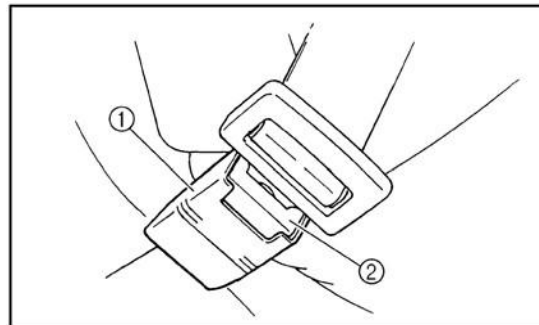

5. To release the buckle, firmly press the

⚠ WARNING

POTENTIAL HAZARD

Not wearing the seat belt.

Wearing the seat belt improperly.

WHAT CAN HAPPEN

There is increased risk of being killed or seriously injured in an accident.

HOW TO AVOID THE HAZARD

Always wear your seat belt when riding in the vehicle.

Be sure the seat belt is close-fitting across your hips and chest and is latched securely.

release button.

-
- 1. Buckle
 - 2. Release button
- Cargo Bed**

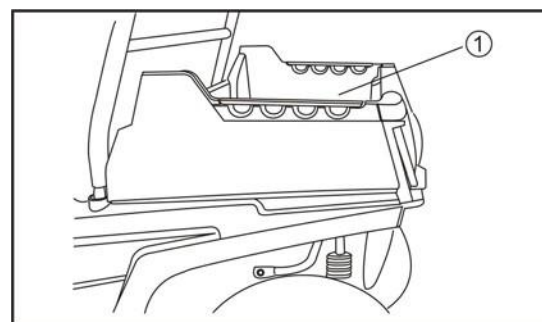

1. Cargo bed

Maximum load limit: 350lb (159kg)

⚠ WARNING

POTENTIAL HAZARD

Overloading the cargo bed.

WHAT CAN HAPPEN

Could cause changes in vehicle handling which could lead to an accident.

HOW TO AVOID THE HAZARD

Never exceed the stated maximum load limit for this cargo bed.

Cargo should be properly distributed and securely attached.

Reduce speed when carrying cargo.

Allow greater distance for braking.

Front and Rear Shock Adjustment

<p>⚠ WARNING</p>
<p><u>POTENTIAL HAZARD</u> Carrying a passenger in the cargo bed.</p> <p><u>WHAT CAN HAPPEN</u> The passenger could fall, be thrown out, or be struck by objects in the cargo bed.</p> <p><u>HOW TO AVOID THE HAZARD</u> Never carry a passenger in the cargo bed. This cargo bed is designed to carry cargo only.</p>

The spring preload can be adjusted to suit the operating conditions.

You can reduce preload for a softer ride, or increase preload if frequent bottoming occurs.

CAUTION:

Frequent or severe bottoming can cause increased wear or damage to the vehicle.

Adjust the spring preload as follows.

To increase the spring preload, turn the adjusting ring in the direction Ⓐ.

To decrease the spring preload, turn the adjusting ring in the direction Ⓑ.

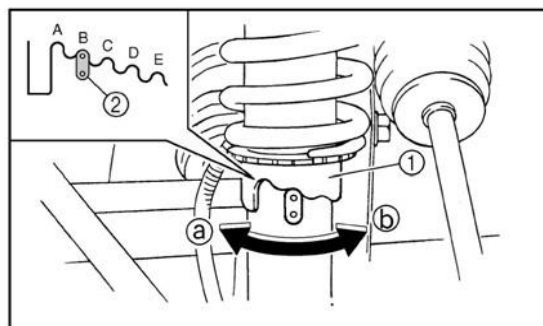

- 1. Spring preload adjusting ring
- 2. Position indicator

NOTE:

A special wrench can be obtained at a dealer to make this adjustment.

Standard position: B
A-Minimum(soft)
E-Maximum(hard)

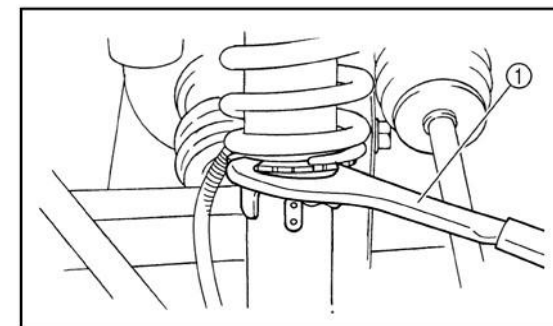

- 1. Special wrench

⚠ WARNING

POTENTIAL HAZARD
Improper shock absorber adjustment.

WHAT CAN HAPPEN
Uneven adjustment can cause poor handling and loss of stability, which could lead to an accident.

HOW TO AVOID THE HAZARD
Always adjust the shock absorbers on the left and right side to the same setting.

Trailer Hitch Bracket

This vehicle is equipped with a 5 cm (2 in) receiver bracket for a standard trailer hitch. Trailer towing equipment can be obtained at a dealer.

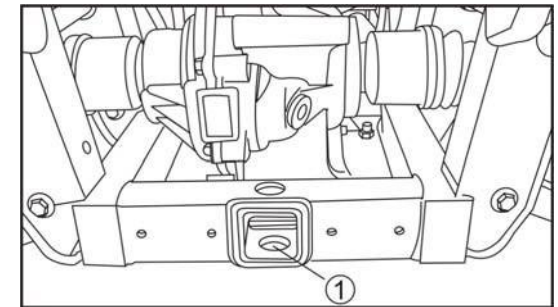

1. Trailer hitch bracket

Auxiliary DC Jack

The auxiliary DC jack is located at the right side of the front panel.

The auxiliary DC jack can be used for suitable work lights, radios, etc. The auxiliary DC jack should only be used when the engine is running.

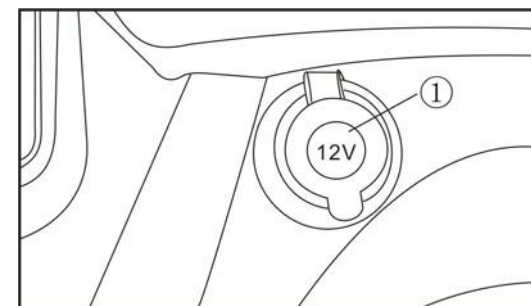

1. Auxiliary DC jack cap

1. Set the light switch to "OFF".

2. Start the engine.
(See pages 6-1-6-3.)
3. Open the

with
the
cap.

auxiliary DC jack cap, and then insert the accessory power plug into the jack.

4. When the auxiliary DC jack is not being used, cover it

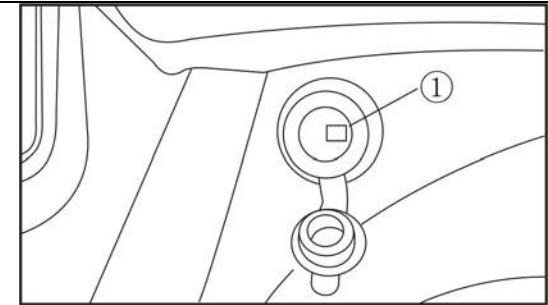

1. Auxiliary DC jack

<p>Maximum rated capacity for the auxiliary DC jack: DC 12V, 120W (10 A)</p>

CAUTION:

- Do not use accessories requiring more than the above maximum capacity. This may overload the circuit and cause the fuse to blow.
- If accessories are used without the engine running or with the headlights turned on, the battery will lose its charge and engine starting may become difficult.

4-30 Control Functions

- Do not use an automotive cigarette lighter or other accessories with a plug that gets hot because the jack can be damaged.
-

Pre Operation Checks 5-1

Before using this vehicle, check the following points:

ITEM	ROUTINE	PAGE
Brakes	<ul style="list-style-type: none"> ● Check operation, free play, fluid level and fluid leakage. ● Fill with DOT 3 brake fluid if necessary. 	5-2—5-3, 8-30—8-31
Parking brake	<ul style="list-style-type: none"> ● Check for proper operation, condition and free play. 	6-6—6-7
Fuel	<ul style="list-style-type: none"> ● Check fuel level. ● Fill with fuel if necessary. 	5-4—5-5
Engine/Gear box oil	<ul style="list-style-type: none"> ● Check oil level. ● Fill with oil if necessary. 	5-6
Coolant reservoir	<ul style="list-style-type: none"> ● Check coolant level. ● Fill with coolant if necessary. 	5-6, 8-19—8--20
Final gear oil / Differential gear oil	<ul style="list-style-type: none"> ● Check for leakage. 	5-7
Accelerator pedal	<ul style="list-style-type: none"> ● Check for proper accelerator pedal operation. 	5-8—5-10
Seat belts	<ul style="list-style-type: none"> ● Check for proper operation and belt wear. 	5-10
Steering	<ul style="list-style-type: none"> ● Check for proper operation . 	5-10
Fittings and fasteners	<ul style="list-style-type: none"> ● Check all fittings and fasteners. 	5-11
Lights and switches	<ul style="list-style-type: none"> ● Check for proper operation. 	5-11
Wheels and tires	<ul style="list-style-type: none"> ● Check tire pressure, wear and damage. 	5-2—5-15, 8-37-8-38
Axle boots	<ul style="list-style-type: none"> ● Check for damage. 	8-20-8-21

5-2 Pre Operation Checks

Instrument	● Check for complete and right display	4-2-4-8
Light/Indicator	● Check for light / indicator operation	4-2-4-8

Brakes

5-4 Pre Operation Checks

⚠ WARNING	
<u>POTENTIAL HAZARD</u>	
Failure to inspect the vehicle before operating. Failure to properly maintain the vehicle.	Always check brake pedal travel and the brake fluid reservoir level before each use of the vehicle. When applied, the brake pedal should feel firm. Any sponginess would indicate a possible fluid leak or low brake fluid level, which must be corrected before riding.
<u>WHAT CAN HAPPEN</u>	
Increases the possibility of an accident or equipment damage.	If you discover any irregularities in brake system operation, including excessive pedal travel, contact your dealer for proper diagnosis and repairs.
<u>HOW TO AVOID THE HAZARD</u>	
Always inspect your vehicle each time you use it to make sure the vehicle is in safe operating condition. Always follow the inspection and maintenance procedures and schedules described in the Owner's Manual.	Front and Rear Brakes Brake Pedal Check for correct brake pedal free play. If the brake pedal free play is incorrect, have a dealer adjust it. Check the operation of the brake pedal. It

should
move
smoothly
and there
should be a
firm feeling

brake fluid
is leaking
out of the
pipe joints
or the brake
fluid

when the
brakes are
applied. If
not, have
the vehicle
inspected
by a dealer.

reservoir.
Apply the
brakes
firmly for
one minute.
If there is
any
leakage,
have the
vehicle
inspected
by a dealer.

**Brake Fluid
Level**

Check the
brake fluid
level.

Add fluid if
necessary.

Brake Operation

Test the brakes at slow speed after starting out to make sure they are working properly. If the brakes do not provide proper braking performance, inspect the brake system.

Recommen
ded brake
fluid: DOT 3

**Brake Fluid
Leakage**

Check to
see if any

5-6 Pre Operation Checks

Fuel

Make sure there is sufficient gasoline in the tank.

⚠ WARNING

POTENTIAL HAZARD

Driving with improperly operating brakes.

WHAT CAN HAPPEN

You could lose braking ability, which could lead to an accident.

HOW TO AVOID THE HAZARD

Always check the brakes at the start of every ride. Do not operate the vehicle if you find any problem with the brakes. If a problem cannot be corrected by the adjustment procedures provided in this manual, have the vehicle inspected by a dealer.

Recommended fuel:

Unleaded gasoline only Fuel

tank capacity:

26.0L (5.71Imp gal, 6.87US gal)

CAUTION:

Use only unleaded gasoline. The use of leaded gasoline will cause severe damage to internal engine parts, such as the valves and piston rings, as well as to the exhaust system.

Your engine has been designed to use regular

⚠ WARNING

<p>unleaded gasoline with a pump octane number $([R+M] / 2)$ of 91 or higher, or research octane number of 91 or higher. If knocking or pinging occurs, use a different of gasoline or premium unleaded fuel. Unleaded fuel will give you longer spark plug and reduced maintenance cost.</p>	<p><u>POTENTIAL HAZARD</u> Improper care when refueling. <u>WHAT CAN HAPPEN</u> Fuel can spill, which can cause a fire and severe injury. Fuel expands when it heats up. If the fuel tank is overfilled, fuel could spill out due to heat from the engine or the sun. <u>HOW TO AVOID THE HAZARD</u> Do not overfill the fuel tank. Be careful not to spill fuel, especially on the engine or exhaust pipe. Wipe up any spilled fuel immediately. Be sure the fuel tank cap is closed securely.</p>
<p>Gasoline The UTV uses an electric fuel injection system, and its emissions completely meet the requirements of relevant rule of the United States and Europe. But mixed fuel is forbidden to use on the UTV, because its injection quantity is different from gasoline. The mixed fuel will cause engine to work abnormally and exhaust to be deteriorated.</p>	

brand
 life

5-8 Pre Operation Checks

Engine/Reduction Gear box Oil

Make sure the engine/reduction gear box oil is at the specified level. Add oil as necessary. (The coolant level will vary with engine temperature.)

CAUTION:

- In order to prevent clutch slippage (since the engine oil also lubricates the clutch), do not mix any chemical additives. Do not use oils with a diesel specification of “CD” or oils of a higher quality than specified. In addition, do not use oils labeled “ENERGY CONSERVING II” or higher.
- Make sure that no foreign material enters the crankcase. You may use soft water if you cannot get _____ distilled water.

Coolant

Check the coolant level in the coolant reservoir when the engine is cold. (The coolant level will vary with engine temperature.)

The coolant level is satisfactory if it is between the minimum and maximum level marks on the coolant reservoir. If the coolant level is at or below the minimum level mark, add additional coolant to bring the level up to maximum level mark. If coolant is not available, add distilled water. Change the coolant every two years. (See pages 8-19—8-20) for details.

CAUTION: _____ Hard water or salt water is harmful to the engine.

distilled

Recommended engine
oil type and
quantity:
See page 10-2

Coolant reservoir capacity
(up to the maximum level mark):
0.627L(0.555Imp qt, 0.663US qt)

level. Add oil as necessary. (See pages 8-14

5-10 Pre Operation Checks

⚠ WARNING

POTENTIAL HAZARD

Removing the radiator cap when the engine and radiator are still hot.

WHAT CAN HAPPEN

You could be burned by hot fluid and steam blown out under pressure.

HOW TO AVOID THE HAZARD

Wait for the engine to cool before removing the radiator cap. Always use a thick rag over the cap. Allow any remaining pressure to escape before completely removing the cap.

Final Gear Oil

Make sure the final gear oil is at the specified

—8-15 for details.)

If Recommended oil:
SAE 80 API GL-4 Hypoid gear oil

desired, An SAE 80W90 hypoid gear oil may be used for all conditions. **NOTE:** GL-4 is a quality and additive rating, GL-5 or GL-6 rated hypoid gear oils may also be used.

Differential Gear Oil

Make sure the differential gear oil is at the specified level. Add oil as necessary. (See pages 8-16—8-18 for details.)

Recommended oil:
SAE 80 API GL-5 Hypoid gear oil

Adjustment of steering wheel:

You can adjust the height of

the steering board according to the driver's height and driving habits.

1. Move handlebar to "vertical upper" direction and hold.
2. Adjust the steering board up and down to get it in proper position.

3. Loose the handle bar to fix the steering wheel in the position you want.

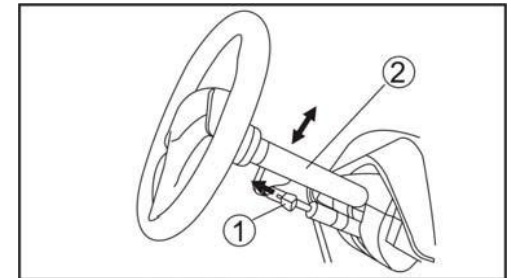

1. Adjust lever 2. Steering column

Throttle Pedal

Check to see that the accelerator pedal operates correctly. It must operate smoothly and fully spring back to the idle position when released. Have a dealer repair as necessary for proper operation.

5-12 Pre Operation Checks

⚠ WARNING

Failure to check or maintain proper operation of the throttle system can result in an accident and lead to serious injury or death if the throttle pedal sticks during operation.

Never start or operate this vehicle if it has a sticking or improperly operating throttle pedal.

Immediately contact your dealer for service if throttle problems arise.

Always check the pedal for free movement and return before starting the engine and occasionally during operation.

Throttle Free-play

If the throttle pedal has excessive play due to cable stretch or mis-adjustment, it will cause a delay in throttle response, especially at low engine speed. The throttle may also not open fully. If the throttle pedal has no free-play, the throttle may be hard to control, and the idle speed may be erratic.

Check the throttle pedal free-play, Adjust the free-play if necessary.

Throttle Free-play Inspection

1. Lift the parking brake to the top to park the car.
2. Apply the brakes. Start the engine. Allow it to warm up thoroughly.
3. Measure the distance the throttle pedal moves before the engine begins to pick up speed. Free-play should 1/16 to 1/8 inches

(1.5-3mm).

Throttle Free-play Adjustment

1. Remove both seats. Remove the middle cover of the engine, (see PAGE 8-6)
2. Loose the nut of throttle rope on the valve, Spin the throttle rope inside/ outside to increase the throttle pedal's moving distance to 1.5-3 mm.

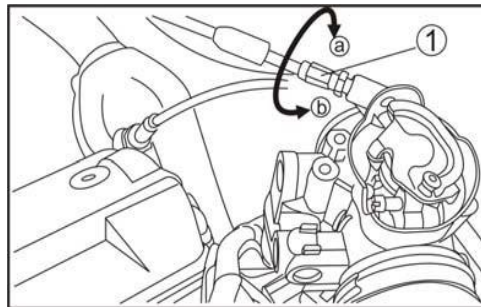

1. Accelerator Cable column nut

3. Fix the nut.
4. Resume the center cover and seat to their position

Steering Wheel Inspection

Check the steering wheel for specified free-play and smooth operation.

1. Position the vehicle on level ground.
2. Lightly turn the steering wheel left and right.
3. There should be 0.8" -1.0" (20-25 mm) of free-play.

If there is excessive free-play or strange noises, or the steering feels rough or "catchy," have the steering system

inspected by an authorized dealer. **Seat**

Belts

Make sure that both seat belts are not frayed or damaged.

The seat belt must move smoothly when pulled out and retract on its own when released. The latch plate should click securely into the buckle and release when the release button is pushed firmly. Wash off any dirt or mud which could affect operation. Have a dealer repair as necessary for proper operation.

Fittings and Fasteners

Always check the tightness of chassis fittings and fasteners before a ride. Take the vehicle to a dealer or refer to the Service Manual for correct tightening torque.

Lights

Check the headlights and tail/brake lights to make sure they are in working condition. Repair as necessary for proper operation.

Switches

Check the operation of all switches. Have a dealer repair as necessary for proper operation.

5-14 Pre Operation Checks

Tires

WARNING		
<u>POTENTIAL HAZARD</u>		
Operating this vehicle with improper tires, or with improper or uneven tire pressure.		
<u>WHAT CAN HAPPEN</u>		
Use of improper tires on this vehicle, or operation of this vehicle with improper or uneven tire pressure, may cause loss of control, increasing your risk of accident.		
1. The tires listed below have been approved.		
	Type	Inflation pressure
Front	26×9-14	100kPa (14psi)
Rear	26×11-114	100kPa (14psi)
2. The tires should be set to the recommended		
pressure: Check and adjust tire pressures when the tires are cold. Tire pressures must be equal on both sides. 3. Tire pressure below the minimum specified could cause the tire to dislodge from the rim under severe riding conditions. 4. Use no more than the following pressures when seating the tire beads. Higher pressures may cause the tire to burst. Inflate the tires very slowly and carefully. Fast inflation could cause the tire to burst.		
How to Measure Tire Pressure Use the tire pressure gauge. NOTE: The tire pressure gauge is included as standard		

5-16 Pre Operation Checks

equipment. Make two measurements of the **Tire Wear Limit** tire pressure and use the second reading. When the tire groove decreases to 3 mm (0.12 in) due to wear, replace the tire. Dust or dirt in the gauge could cause the first in) due to wear, reading to be incorrect.

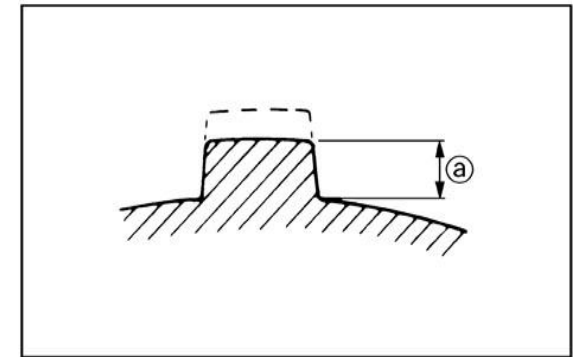
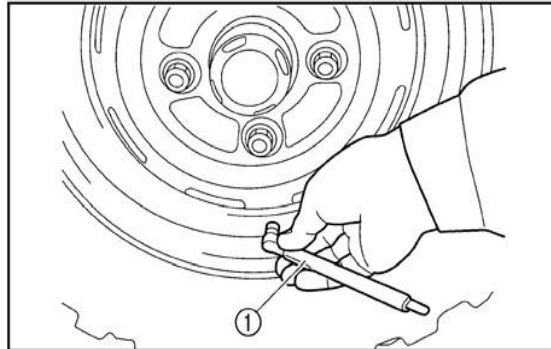

a. Tire wear limit

-
1. Tire pressure gauge

6-1 Operation

⚠ WARNING

POTENTIAL HAZARD

Operating vehicle without being familiar with all controls.

WHAT CAN HAPPEN

Loss of control, which could cause an accident or injury.

HOW TO AVOID THE HAZARD

Read the Owner's Manual carefully. If there is a control or function you do not understand, ask your dealer.

Starting the Engine in Low Temperatures

1. Check the throttle cable, parking cable, and the reverse lock out cable, and make sure that they are not frozen.
2. Start the engine (see P6-2).

Starting The Engine

CAUTION:

See the "Engine Break-In" section prior to operating the engine for the first time.

⚠ WARNING

POTENTIAL HAZARD

Freezing control cables in cold weather.

WHAT CAN HAPPEN

You could be unable to control the vehicle, which could lead to an accident or collision.

HOW TO AVOID THE HAZARD

When riding in cold weather, always make sure all control cables work smoothly before you begin riding.

1. Turning the key to "ON", the light in the display will turn on, and electronic

injection system's fuel pump will start to work;

neutral position.

NOTE:

- When the drive select lever is in the neutral position "N", the neutral indicator

wait for 10 second before the following operation.

light should come on. If the neutral indicator light does not come on, ask a dealer to inspect the electric circuit.

2. Apply the brake.
3. Shift the drive select lever into the

- The engine can be started in any gear if the brake is applied. However, it is recommended to shift into neutral ("N") before starting the engine.

4. With your foot off the accelerator pedal, start the engine by turning the key to "START".

NOTE: _____ If the engine fails to start, release the key, and then try starting again. Wait a few seconds before the next attempt. Each cranking should be as short as possible to preserve battery energy. Do not crank the engine more than 5 seconds on each _____ attempt.

⚠ WARNING

is over 12V, the idle speed will be normal. If the idle speed is still high, please contact your dealer.

6-3 Operation

POTENTIAL HAZARD

Engine idle speed exceeds the regulated speed.

WHAT CAN HAPPEN

Will make it difficult to select gear and lose control, finally causing serious injury or even death.

HOW TO AVOID THE HAZARD

Because of electronic injection system, the idle speed will be speed up when the voltage of battery is low.

Place the gear on position 'N', and press the throttle pedal to make the engine run at 2500RPM to charge the battery for 5-10 minutes; when the voltage of battery

5. Continue warming up the engine until it idles smoothly before riding.

Warming Up

To get maximum engine life, always warm up the engine before driving. Never accelerate hard

with a cold engine! To see whether or not the engine is warm, check if it responds to the throttle normally .

1. Release the brakes and press the accelerator pedal gradually.
2. If the rotation rate of the engine accelerates with pedal steadily, the warming-up procedure has been ready and the vehicle can be ridden.
Otherwise, go on with the third step.
3. Continue warming up the engine until it idles smoothly.

CAUTION: _____ See the “Engine break-in” section prior to operating the engine for the first time.

Shifting: Neutral to High and High to Low

1. Bring the UTV to a complete stop and return the accelerate pedal to the closed position.
2. Apply the brakes, then shift by moving the drive select lever along the shift guide.

NOTE: _____ Make sure that the drive select lever is completely shifted into position.

Drive Select Lever Operation And Driving In Reverse

CAUTION:

Before shifting, you must stop the UTV and return the accelerate pedal to the closed position, otherwise the transmission may be damaged.

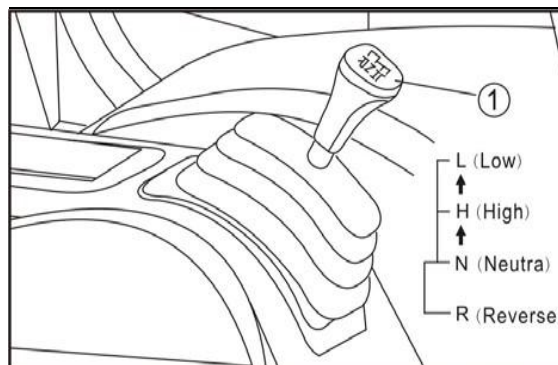

1. Drive select lever

Shifting: Neutral to Reverse

NOTE:

The drive select lever cannot be shifted into or from reverse without applying the brake.

1. Bring the UTV to a complete stop and return the accelerate pedal to the closed position.
2. Apply the brake pedal.
3. Shift from neutral to reverse and vice versa by moving the drive select lever along the shift guide.

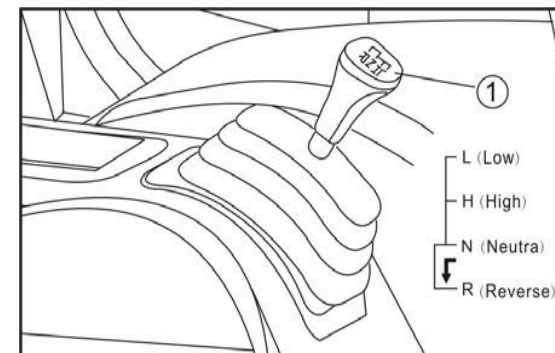

1. Drive select lever

NOTE:

- When in reverse, the reverse indicator light should be on. If the light does not come on, ask a dealer to inspect the electrical circuit.
- Due to the synchronizing mechanism in the engine, the light may not come on until the UTV starts moving.

4. Check behind for people or obstacles, and then release the brake pedal.

5. Press down the accelerate pedal gradually and continue to watch to the rear while backing.

⚠ WARNING

POTENTIAL HAZARD

Improperly operating in reverse.

WHAT CAN HAPPEN

You could hit an obstacle or person behind you, resulting in serious injury.

HOW TO AVOID THE HAZARD

When you shift into reverse, make sure there are no obstacles or people behind you.

When it is safe to proceed, go slowly.

Parking

1. When parking, stop the engine and shift the drive select lever into the neutral position.
2. Push the brake pedal down, and pull the parking brake to top position to park the vehicle

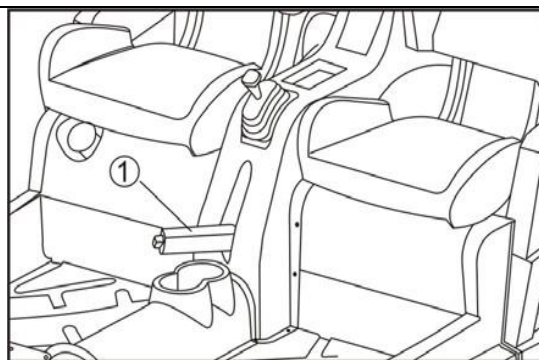

1. Parking hand-bar

⚠ WARNING

POTENTIAL HAZARD

Parking on a hill or other incline.

WHAT CAN HAPPEN

The vehicle could roll out of control, increasing the chance of an accident.

HOW TO AVOID THE HAZARD

Avoid parking on hills or other inclines. If you must park on an incline, apply the parking brake, and block the front and rear wheels with rocks or other objects. Do not park the vehicle at all on hills that are so steep you could not walk up them easily.

Parking on a Slope

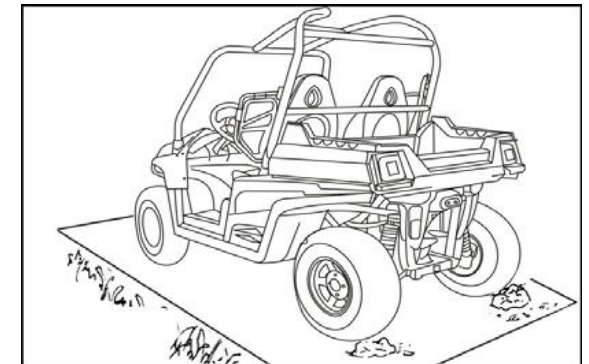

1. Bring the vehicle to a stop by applying the brakes.
2. Stop the engine.
3. With the parking hand-bar applied, set the

- parking brake.
4. Put a big rock or wedge-shaped pieces of wood in the downhill direction of the wheel, to ensure that the car will not slide

to the slopes accidentally.

Vehicle Break-in

Period

The break-in period for your new UTV vehicle is the first 25 hours of operation, or the time it takes to use the first three tanks full of gasoline. No single action on your part is as important as a proper break-in period. Careful treatment of a new engine and drive components will result in more efficient performance and longer life for these

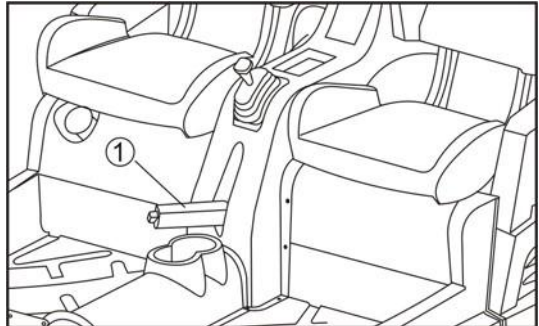

1. Parking hand-bar components. Perform the following

NOTE: _____ procedures carefully.

Like many other vehicles, the parking brake

CAUTION:

- Excessive heat build-up during the first acts on the rear wheels. For the parking three hours of operation will damage brake to operate all four wheels, shift to 4WD

drive before stopping the engine. _____ close-fitted engine parts and full components. Do not operate at

three hours of use.

- Use of any engine oil not mentioned in this manual will cause severe damage to the engine.

Engine Break-In

There is never a more important period in the life of your vehicle than the period between zero and 25 hours.

For this reason, we ask that you carefully read the following material. Because the engine is brand new, you must not put an

throttle or high speeds during the first excessive load on it for the first several hours of running.

During the first 25 hours, the various parts in the engine wear and polish themselves to the correct operating clearances.

During this period, prolonged full throttle operation or any condition which might result in excessive engine heating must be avoided. However, momentary (2-3 seconds maximum) full throttle operation under load does not harm the engine.

Each full throttle acceleration sequence should be followed with a substantial rest period for the engine by cruising at lower r/min

so the engine can rid itself of the temporary build up of heat. If any abnormality is noticed during this period, consult a dealer.

0-10 Hours:

Avoid continuous operation above half throttle. Allow a cooling off period of five to ten minutes after every hour of operation. Vary the speed of the vehicle from time to time. Do not operate it at one set throttle position.

10-25 Hours:

Avoid prolonged operation above 3/4 throttle. Rev the vehicle freely but do not use full throttle at any time.

After Break-In:

The vehicle can now be operated normally.

Brake System Break-in

Apply only moderate braking force for the first 50 stops. Aggressive or overly forceful braking when the brake system is new could damage brake pads and rotors.

CVT Break-in (Clutches/Belt)

A proper break-in of the clutches and drive belt will ensure a longer life and better performance. Break in the clutches and belt by operating at slower speeds during the break-in period as recommended. Pull only light loads. Avoid aggressive acceleration and high speed operation during the break-in period.

Accessories and Loading

Accessories

Accessories can affect the handling and control of your vehicle. Keep the following in mind when considering an accessory or operating a vehicle which has accessories.

- Choose only accessories designed for your vehicle. Your dealer has a variety of genuine accessories. Other accessories may also be available on the market. However, it is not possible to test all non factory accessories, nor have any control over the quality or suitability of them. Choose a genuine accessory, or one that is equivalent in design and quality.
- Accessories should be rigidly and securely mounted. An accessory which can shift position or come off while you are

operating could affect your ability to control the vehicle.

- Do not mount an accessory where it could interfere with your ability to control the vehicle. Examples include (but are not limited to) an object that limits your ability to turn the steering wheel or one that limits your view.
- Use extra caution when driving a vehicle with accessories. The vehicle may handle differently than it does without accessories.

Loading

Carrying cargo or towing a trailer can change the stability and handling of a vehicle.

You must use common sense and good judgment when carrying cargo or towing a trailer. Keep the following points in mind:

- Never exceed the weight limits shown.

An overloaded vehicle can be unstable.

MAXIMUM LOADING LIMIT

- Vehicle loading limit (total weight of cargo, operator, passengers and accessories, and tongue weight): 880 lb (399 Kg)
- Cargo bed: 350 lb (159Kg) ●
- Trailer hitch:
 Pulling load (total weight of trailer and cargo): 1200 lb (544Kg)
- Tongue weight (vertical weight on trailer hitch point): 110 lb (50Kg)

- Choose a trailer hitch drawbar designed for use with a 5 cm (2in) receiver. (See page 4-29 for more information)
- Do not exceed the maximum tongue weight. You can measure tongue weight with a bathroom scale. Put the tongue of the loaded trailer on the scale with the tongue at hitch height. Adjust the load in the trailer, if necessary, to reduce the weight on hitch. If you are carrying cargo and towing a trailer, include the tongue weight in the maximum vehicle load limit.
- Load cargo in the cargo bed as close to the center of the vehicle as possible and tie it down using the cargo hooks equipped on the cargo bed.
- Tie down cargo securely in the trailer. Make sure cargo in the trailer cannot move

around. A shifting load can cause an accident.

- Make sure the load does not interfere with controls or your ability to see where you

are going.

- Drive more slowly than would without a load. Although heavier loads conditions vary, it is good practice not to exceed low range whenever you are carrying or when towing a trailer.
- Allow more braking distance. A heavier vehicle takes longer to stop.
- Avoid making sharp turns unless at very slow speeds.
- Avoid hills and rough terrain. Choose terrain carefully. Added weight affects the stability and handling of the vehicle.

⚠ WARNING

POTENTIAL HAZARD
Overloading this vehicle or carrying or towing cargo improperly.

WHAT CAN HAPPEN
Could cause changes in vehicle handling which could lead to an accident.

HOW TO AVOID THE HAZARD
Never exceed the stated load capacity for this vehicle.
Cargo should be properly distributed and securely attached.
Reduce speed when carrying cargo or pulling a trailer. Allow greater distance for braking.

slowly than would without a load. The more weight you carry, the slower you should go. Although heavier loads conditions vary, it is good practice not to exceed low range whenever you are carrying or when towing a trailer. A heavier vehicle takes longer to stop. sharp turns unless at very slow speeds. rough terrain. Choose terrain carefully. Added weight affects the stability and handling of

DRIVING YOUR VEHICLE

Getting To Know Your Vehicle

This off-highway utility vehicle will handle and maneuver differently from an ordinary passenger car or other vehicle. Before you begin to use your vehicle, be sure you have read this Owner's Manual completely and understand all of the controls. Pay particular attention to the safety information on pages 2-1—2-5. Please also read all caution and warning labels on your vehicle.

This vehicle is designed for the operator and one passenger. The driver and passenger must always wear a seat belt. Never carry passenger in the cargo bed.

WARNING

POTENTIAL HAZARD

Not wearing the seat belt.

Wearing the seat belt improperly.

WHAT CAN HAPPEN

There is increased risk of being killed or seriously injured in an accident.

HOW TO AVOID THE HAZARD

Always wear your seat belt when riding in the vehicle.

Be sure the seat belt is close-fitting across your hips and chest and is latched securely.

The total weight of operator, passenger,

7-2 Your Vehicle

⚠ WARNING

POTENTIAL HAZARD

Carrying a passenger in the cargo bed.

WHAT CAN HAPPEN

The passenger could fall or be struck by objects in the cargo bed.

HOW TO AVOID THE HAZARD

Never carry a passenger in the cargo bed. The cargo bed is designed to carry cargo only.

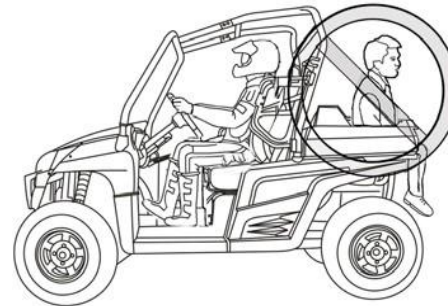

accessories, cargo, trailer tongue weight, and the vehicle itself must not exceed lbs (Kg).

⚠ WARNING

POTENTIAL HAZARD

Overloading this vehicle or carrying or towing cargo improperly.

WHAT CAN HAPPEN

Could cause changes in vehicle handling which could lead to an accident.

HOW TO AVOID THE HAZARD

Never exceed the stated load capacity for this vehicle.

Cargo should be properly distributed and securely attached.

Reduce speed when carrying cargo or pulling a trailer. Allow greater distance for braking.

Always follow the instructions in your Owner's Manual for carrying cargo or pulling a trailer.

The driver and passenger must always wear a seat belt and an approved motorcycle helmet. Also wear eye protection and protective clothing, including over-the-ankle boots, gloves, a long-sleeved shirt or jacket, and long pants. Keep hands and feet inside the vehicle at all times.

7-4 Your Vehicle

⚠ WARNING

POTENTIAL HAZARD

Operating this vehicle without wearing an approved motorcycle helmet, eye protection, and protective clothing.

WHAT CAN HAPPEN

Operating without an approved motorcycle helmet increases your chances of a severe head injury or death in the event of an accident.

Operating without eye protection can result in an accident and increases

accelerator pedal, brakes, steering, and drive select lever. Drive first at slow speed and become comfortable at that speed before gradually increasing your speed. Become familiar with the way the vehicle feels in low and high ranges, first in two-wheel drive (2WD) and then in four-wheel drive (4WD) and four-wheel drive with the differential locked. Also practice driving in reverse. Take the time to learn basic

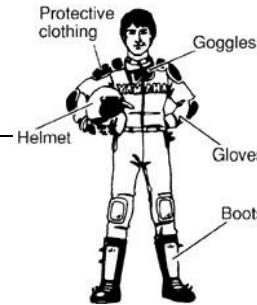

your chances of a severe injury in the event of an accident.

HOW TO AVOID THE HAZARD

Always wear an approved motorcycle helmet that fits properly. You should also wear:

**Eye Protection
(Goggles or Face Shield)**

Gloves

Boots

Long-Sleeved Shirt or Jacket Long

Pants

Your Vehicle 7-5

Learning To Operate Your Vehicle

You should become familiar with the performance characteristics of the vehicle in a large, flat area that is free of obstacles and other vehicles. Practice control of the operation before attempting more difficult maneuvers.

Perform the Pre-Operation Checks on pages 5-1—5-15. Set the parking brake, shift to neutral, and follow the instructions on page 6-1 to start the engine. Once it has warmed up and you have turned the choke off, you are ready to begin driving your vehicle. With the engine idling, shift the drive select lever into low or high. Then release the parking brake. Press the accelerator pedal slowly and smoothly. The centrifugal clutch will engage and you will start to accelerate.

7-6 Your Vehicle

Avoid higher speeds until you are thoroughly familiar with the operation of your vehicle. When slowing down or stopping, take your foot off the accelerator pedal and smoothly press the brake pedal. Improper use of the brakes can cause the tires to lose traction, reducing control and increasing the possibility of an accident.

CAUTION:

Do not shift from low to high or vice versa without coming to a complete stop and waiting for the engine to return to normal idle speed. Damage to the engine or drive train may occur.

Turning Your Vehicle

The vehicle is easier to steer in two-wheel drive (2WD) than four-wheel drive (4WD).

Steering takes the most effort in 4WD with the differential locked.

It is possible for the vehicle to roll over or go out of control if you attempt sharp, high-speed turns. You should also be careful making sharp turns on rough terrain. Do not attempt to turn around or make abrupt maneuvers on slope.

Position your hands on the steering wheel so that your thumbs and fingers do not wrap around the wheel. This is particularly important when driving in rough terrain. The front wheels will move right and left as they respond to the terrain, and this movement will be felt in the steering wheel. A sudden jolt could wrench the steering wheel around, and your thumbs or fingers could be injured if they are in the way of the steering wheel spokes.

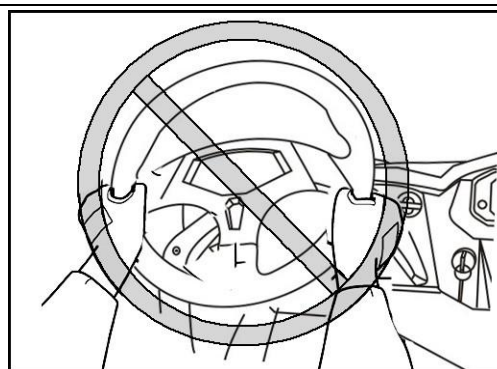

Operating Improperly in Reverse

Improperly operating in reverse could result in a collision with an obstacle or person.

Always follow proper operating procedures.

1. Always check for obstacles or people behind the vehicle.
2. Apply the accelerate pedal lightly. Never press down the accelerate pedal suddenly.
3. Back slowly.
4. Apply the brakes lightly for stopping.
5. Avoid making sharp turns.

Before shifting into reverse gear, always check for obstacles or people behind the vehicle. When it's safe to proceed, back slowly.

Follow these precautions when operating in reverse:

7-8 Your Vehicle

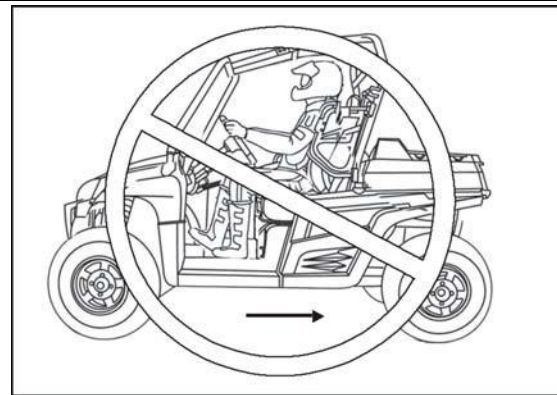

Cab Nets and Shoulder Protection Plate

Your vehicle is equipped with cab nets and shoulder protection plates on both sides of the vehicle. Cab nets and shoulder protection plates must be used by both operator and passenger at all times. Promptly replace worn or damaged cab nets with new,, available

from your authorized dealer allow component identification. Always use the cab nets and shoulder protection plates.

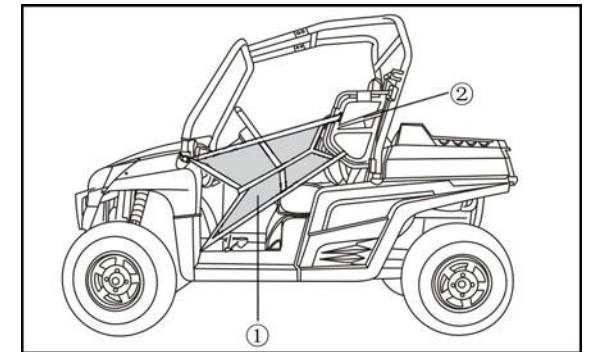

1、 Cab Nets 2、 Shoulder Protection Plate

Braking

Braking ability is affected by the type of terrain. In most cases, gradually application of the brakes is more effective than abrupt braking,

Maximum slope angle: 15° with full loading (300kg)

particularly on loose surfaces like gravel. Always allow for greater braking distance on rough, loose, or slippery surfaces.

Going

Uphill

Do not attempt to climb hills until you have mastered basic maneuvers on flat ground. Use proper driving techniques to avoid overturns on hills and slopes. Drive straight up hills, and avoid crossing the side of a hill, which increases your chance of rollover. Practice first on gentle slopes before attempting steeper hills. Always check the terrain carefully before attempting any hill. Use common sense and remember that some hills are too steep for you to climb.

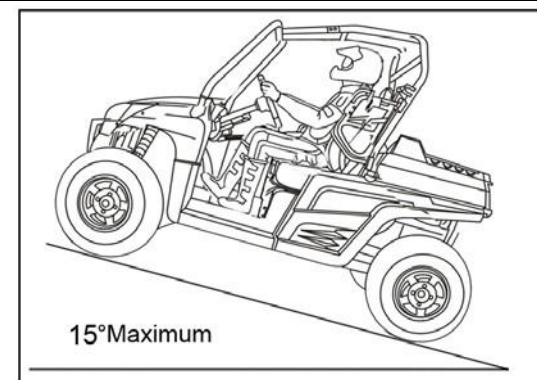

7-10 Your Vehicle

WARNING

POTENTIAL HAZARD

Operating on excessively steep hills.

WHAT CAN HAPPEN

The vehicle can over turn more easily on extremely steep hills than on level surfaces or small hills.

HOW TO AVOID THE HAZARD

Never operate your vehicle on hills too steep for it or your abilities. Never operate vehicles on hills steeper than 15°.

Do not drive across the face of a hill. Go straight up the hill.

Practice on smaller hills before attempting large hills.

Choose carefully which hills you attempt to climb. Avoid hills with slippery surfaces or ones where you will not be able to see far enough ahead of you.

Before climbing the hill, first be sure you are operating in low range 4WD or, if necessary, with 4WD. To climb a hill, you

need traction, momentum, and steady throttle.

could be another person, an obstacle, or a sharp

Travel fast enough to keep your momentum going, but not so fast that you cannot react to changes in the terrain as you climb. Slow down when you reach the crest of the hill if you cannot clearly see what is on the other side. There

drop off. If you start to lose traction or momentum when climbing, and you decide you will be unable to continue, use the brakes to come to a stop. Do not attempt to turn the vehicle around. With your foot on the

7-12 Your Vehicle

brake, look behind you and plan your descent.

coast down the hill. Use engine braking as much as

Shift the drive select lever in reverse so you can use the engine brake if necessary to slow your descent.

possible, gently applying the brakes when necessary.

Release the brake and begin to

Going Downhill

Check the terrain carefully before going down a hill. When possible, choose a path that lets you drive your vehicle straight downhill. Avoid sharp angles that could allow the vehicle to pitch or roll over. Carefully choose your path and drive no faster than you will be able to react to obstacles that may appear.

 **WARNING**

<p><u>POTENTIAL HAZARD</u> Going down a hill improperly. <u>WHAT CAN HAPPEN</u> Could cause loss of control or cause the vehicle to overturn. <u>HOW TO AVOID THE HAZARD</u> Always check the terrain carefully before you start down any hill. Never go down a hill at high speed. Avoid going down a hill at an angle that would cause the vehicle to lean sharply to one side. Go straight down the hill where possible.</p>	<p>vehicle is in low-range 4WD. On most slopes, this will let you use engine braking to help you go downhill slowly. Go as slowly as possible. If you start going too fast, gently apply the brakes. Avoid sudden application of the brakes, which could cause the vehicle to start sliding.</p> <p>If you are sliding or skidding, try to steer in the direction the vehicle is sliding to help you regain control.</p> <p>If you must turn on the hill to avoid an obstacle, do so slowly and carefully. If the vehicle starts to tip, gradually steer in the downhill direction if there are no obstacles in your path. As you regain proper balance, gradually steer again in the direction you want to go.</p>
----------------------------------------------------------------------------------------------------------------------------------------------------------------------------------------------------------------------------------------------------------------------------------------------------------------------------------------------------------------------------------------------------------------------------------------------------------------------------------------------------	---------------------------------------------------------------------------------------------------------------------------------------------------------------------------------------------------------------------------------------------------------------------------------------------------------------------------------------------------------------------------------------------------------------------------------------------------------------------------------------------------------------------------------------------------------------------------------------------------------------------------------------------------------------------------------------------------------------------

Before starting down hill, make sure the

7-14 Your Vehicle

Crossing Through Shallow Lou Water

If you must cross shallow, slow moving water up to the depth of the vehicle's floorboards, choose your path carefully to avoid sharp drop-offs, large rocks, or slippery surfaces that could cause the vehicle to overturn. Never operate through water deeper than 33 cm (13in) or fast flowing water. Wet brakes may have reduced effectiveness. After leaving the water, test your brakes. If necessary, apply the brakes several times to let friction dry out the linings.

WARNING

POTENTIAL HAZARD

Operating this vehicle through deep or fast-flowing water.

WHAT CAN HAPPEN

Loss of control, which could result in an accident including overturn, which could increase the risk of drowning.

HOW TO AVOID THE HAZARD

Never operate this vehicle in fast flowing water or in water deeper than 33cm (13in).

Remember that wet brakes may have reduced stopping ability. Test your brakes after leaving water. If necessary, apply brakes several times to let friction dry out the linings.

CAUTION:

After riding your vehicle in water, be sure to drain the trapped water by removing the check hose at the bottom of the air filter case, the CVT-belt cooling duct check hose, the drive select lever box check hose and the CVT-belt case drain plug. Wash the vehicle in fresh water if it has been operated in salt water or muddy conditions.

Vehicle Immersion**CAUTION:**

If your vehicle becomes immersed, major engine damage can result if the machine is not thoroughly inspected. Take the vehicle to your dealer before starting the engine.

If it's impossible to take your vehicle to a dealer before starting it, follow the steps outlined below. 1. Move the vehicle to dry land.

2. Check the air box. If water is present, dry the air box and replace the filter with a new filter.
3. Remove the spark plugs.
4. Turn the engine over several times.
5. Dry the spark plugs and reinstall them, or install new plugs.
6. Attempt to start the engine. If necessary, repeat the drying procedure.
7. Take the vehicle to your dealer for service as soon as possible, whether you succeed in starting it or not.
8. If water has been ingested into the CVT, make sure inspect the hole without water left inside. If it is muddy water, open the

7-16 Your Vehicle

CVT cap and wash the parts before reassemble.

9. Check the gearshift, release the water inside. Wash it if it is necessary.

CAUTION:

Make sure all motion parts coated with grease after wash and reassemble.

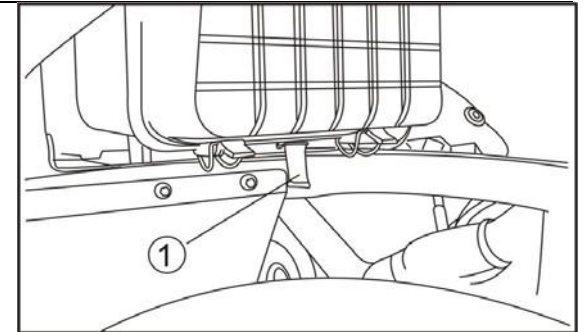

1. Air filter case check hose

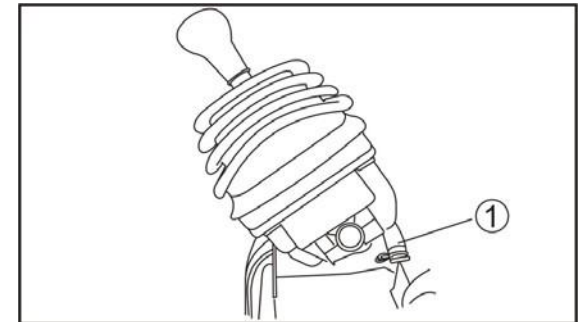

1. Drive select lever box check hose

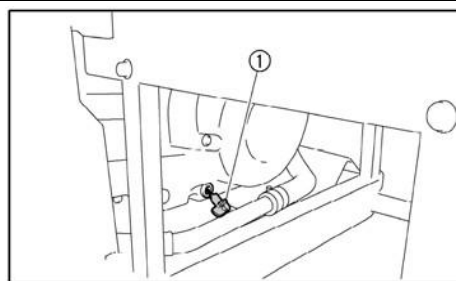

1. CVT Gear Box inspection hole

the rear wheels may continue to slip and will not drive the vehicle ahead.

CAUTION:

The differential case in front axle gearbox uses friction structure and doesn't have lock mechanism, so driver don't need to lock up the differential case.

Rear Axle Differential Lock

When driving on rugged or muddy roads, locking the differential case in the rear axle gearbox will give you the best traction. In this case, the two rear wheels will be driven at the same rate. It may not be useful to lock the differential case after you've lost traction, because the skid process has destroyed the soil structure. Even if you lock the differential,

Riding Over Rough Terrain

Operating over rough terrain should be done with caution. Look for obstacles that could cause damage to the vehicle or could lead to a rollover accident. Avoid jumping the vehicle as injury, loss of control, and damage to the vehicle could occur.

⚠ WARNING

POTENTIAL HAZARD

Failure to use extra care when operating this vehicle on unfamiliar terrain.

WHAT CAN HAPPEN

You can come upon hidden rocks, bumps, or holes, without enough time to react. Could result in the vehicle overturning or going out of control.

HOW TO AVOID THE HAZARD

Go slowly and be extra careful when operating on unfamiliar terrain. Always be alert to changing terrain conditions when operating the vehicle.

7-18 Your Vehicle

Riding in Brush or Wooded Areas

When operating in areas with brush or trees, watch carefully on both sides and above the vehicle for obstacles such as branches that the vehicle might hit, causing an accident,

or
for brush that might enter the vehicle as you pass and strike the driver or passenger. Never hold onto the enclosure so your hand is outside the vehicle. Hold only onto the handgrip inside the enclosure.

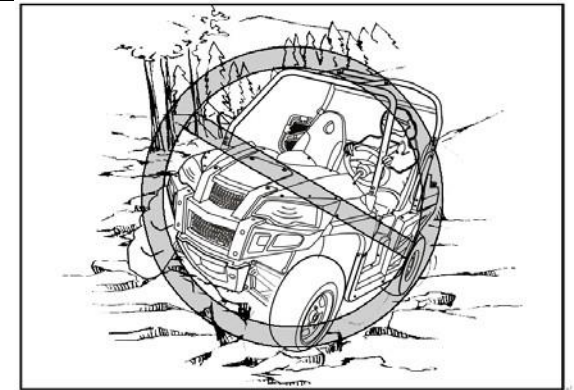

Encountering Obstacles on the Trail

If you cannot go around an obstacle such as a fallen tree trunk or a ditch, stop the vehicle where it is safe to do

so. Set the parking brake and get out to inspecting the area

momentum but still give yourself plenty of time to react to changes

thoroughly. Look from both your approach side and the exit side. If you believe you can continue safely, decide the path that will allow you to get over the obstacle at as close to a right angle as possible to minimize vehicle tipping. Go only fast enough to maintain your

in conditions. If there is any question about your ability to maneuver safely over the obstacle, you should turn around, if the ground is flat and you have the room, or back up until you find a less difficult path.

⚠ WARNING

POTENTIAL HAZARD

Improperly operating over obstacles.

WHAT CAN HAPPEN

Could cause loss of control or a collision. Could cause the vehicle to overturn.

HOW TO AVOID THE HAZARD

Before operating in a new area, check for obstacles.

Use extreme caution when operating over large obstacles, such as large rocks or fallen trees.

Periodic Maintenance and Adjustment 8-1

Periodic Maintenance and Adjustment

Periodic inspection, adjustment and lubrication will keep your vehicle in the safest and most efficient condition possible

e. Safety is an obligation of the vehicle owner. The most important points of vehicle inspection, adjustment and lubrication are explained on the following pages.

The service information included in this manual is intended to provide you, the owner, with the necessary information for completing your own preventive maintenance and minor repairs. The tools provided in the Owner's tool kit are sufficient for this purpose, except that a torque wrench is also necessary to

8-2 Periodic Maintenance and Adjustment

properly
tighten
nuts and
bolts.

NOTE:

If you do not have a torque wrench available during a service operation requiring one, take your vehicle to dealer to check the torque

settings and adjust them as necessary.

F
e
n
i
c
i
c
i
c
M
a
i
n
t
e
n
a



8-4 Periodic Maintenance and Adjustment

⚠️ WARNIN

POTENTIAL HAZARD

Servicing an engine while it is running.

WHAT CAN HAPPEN

Moving parts can catch clothing or parts of the body, causing injury.

Electrical components can cause shocks or can start fires.

HOW TO AVOID THE HAZARD

Turn off the engine when performing maintenance unless otherwise specified.

Have a dealer perform service if you are not familiar with vehicle service.

⚠️ WARNING

POTENTIAL HAZARD

Operating this vehicle with improper modifications.

WHAT CAN HAPPEN

Improper installation of accessories or modification of this vehicle may cause changes in handling which in some situations could lead to an accident.

HOW TO AVOID THE HAZARD

Never modify this vehicle through improper installation or use of accessories. All parts and accessories added to this vehicle should be genuine or equivalent components designed for use on this vehicle and should be installed and used according to instructions.

If you have questions, consult an authorized vehicle dealer.

P
e
r
i
o
d
i
c
M
a
i
n
t
e
n
a



Periodic Maintenance Chart for the Emission Control System

8-6 Periodic Maintenance and Adjustment

- For vehicles not equipped with an odometer or hour meter, follow the month maintenance intervals.
- For vehicles equipped with an odometer or an hour meter, follow the km(mi) or hours maintenance intervals. However, keep in mind that if the vehicle isn't used for a long period of time, the month maintenance intervals should be followed.
- Items marked with an asterisk should be performed by dealer as they require special tools, data and technical skills.

ITEM	ROUTINE	Whichever Comes first ⇒	INITIAL			EVERY		
			Month	1	3	6	6	12
			Km (mi)	320 (200)	1,200 (750)	2,400 (1,500)	2,400 (1,500)	4,800 (3,000)
hours	20	75	150	150	300			
Fuel Line*	<ul style="list-style-type: none"> • Check fuel hose for cracks or damage. • Replace if necessary. 				○	○	○	
Valves*	<ul style="list-style-type: none"> • Check valve clearance. • Adjust if necessary. 		○		○	○	○	
Spark Plug	<ul style="list-style-type: none"> • Check condition. • Adjust gap and clean. • Replace if necessary. 		○	○	○	○	○	
Crankcase Breather System*	<ul style="list-style-type: none"> • Check breather hose for cracks or damage. • Replace if necessary. 				○	○	○	
Exhaust System*	<ul style="list-style-type: none"> • Check for leakage. • Tighten if necessary. • Replace gasket(s) if necessary. 				○	○	○	
Spark Arrester	<ul style="list-style-type: none"> • Clean. 				○	○	○	
Sensor	<ul style="list-style-type: none"> • Clean. 		Clean for each 500km (312mi)					

F
e
r
i
c
o
i
c
M
a
i
n
t
e
n
a



Cooling System	•	Check coolant leakage.	•	○	○	○	○	○
----------------	---	------------------------	---	---	---	---	---	---

8-8 Periodic Maintenance and Adjustment

Repair if necessary. • Replace coolant every 24 months.					
------------------------------------------------------------	--	--	--	--	--

General Maintenance and Lubrication Chart

ITEM	ROUTINE	Whichever Comes first ⇒	INITIAL			EVERY		
			Month	1	3	6	6	12
			Km (mi)	320 (200)	1,200 (750)	2,400 (1,500)	2,400 (1,500)	4,800 (3,000)
			hours	20	75	150	150	300
Air Filter Elements (Engine and Air Intake Duct)	<ul style="list-style-type: none"> • Clean. • Replace if necessary. 		Every 20–40 hours (More often in wet or dusty areas.)					
Engine Oil	<ul style="list-style-type: none"> • Replace (Warm engine before draining.) 		○		○	○	○	
Engine Oil Filter Cartridge	<ul style="list-style-type: none"> • Replace 		○		○	○	○	
Final Gear Oil	<ul style="list-style-type: none"> • Check oil level. Check oil leakage. • Replace. 		○				○	
Differential Gear Oil								
Front Brake*	<ul style="list-style-type: none"> • Check operation/brake pad wear/fluid leakage/seeNOTE page 8-6. • Correct if necessary. Replace pads if worn to the limit. 		○	○	○	○	○	

Rear Brake*	• Check operation/brake pad wear/fluid leakage/see	<input type="checkbox"/>	<input type="checkbox"/>	<input type="checkbox"/>	<input type="checkbox"/>	<input type="checkbox"/>
-------------	----------------------------------------------------	--------------------------	--------------------------	--------------------------	--------------------------	--------------------------

R
e
n
i
c
i
c
i
c
M
a
i
n
t
e
n
a

8-10 Periodic Maintenance and Adjustment

	NOTE page 8-6. • Correct if necessary. Replace pads if worn to the limit.					
Accelerator Pedal*	• Check operation and free play.	○	○	○	○	○
CVT-Belt*	• Check operation. • Check for wear, cracks, or damage.	○			○	○
Wheels*	• Check balance/damage/run out. • Replace if necessary.	○		○	○	○
Wheel Bearings*	• Check bearing assemblies for looseness/damage. • Repair if damaged.					
Front and Rear Suspension*	• Check operation and for leakage. • Check toe-in/Adjust if necessary.			○		○

ITEM	ROUTINE	Whichever Comes first ⇒	INITIAL			EVERY		
			Month	1	3	6	6	12
			Km (mi)	320 (200)	1,200 (750)	2,400 (1,500)	2,400 (1,500)	4,800 (3,000)
			hours	20	75	150	150	300
Steering System*	• Check operation and for looseness. Replace if damaged. • Check toe-in. Adjust if necessary		○	○	○	○	○	

R
e
n
i
c
o
i
c
M
a
i
r
t
e
r
a



Rear Upper and Lower	• Lubricate with lithium-based grease.			○	○	○
----------------------	----------------------------------------	--	--	---	---	---

8-12 Periodic Maintenance and Adjustment

Knuckle Pivots*						
Drive Shaft Universal Joint*	● Lubricate with lithium-based grease.			○	○	○
Engine Mount*	● Check for cracks or damage. ● Check bolt tightness.			○	○	○
Front and Rear Axle Boots*	● Check operation. ● Replace if damaged.	○				○
Anti-Roll Bar Bushings*	● Check for cracks or damage.			○	○	○
Fittings and Fasteners*	● Check all chassis fittings and fasteners. ● Check if necessary.	○	○	○	○	○

NOTE:

- Recommended brake fluid: DOT 3 ● Brake fluid replacement.
- When disassembling the master cylinder or caliper, replace the brake fluid. Normally check the brake fluid level and add fluid as required.
- On the inner parts of the master cylinder and caliper, replace the oil seals every two years.
- Replace the brake hoses every four years, or if cracked or damaged.

Sundry Box Cover To Open/ Close

Unhook the hood latches, and then slowly tilt the sundry box cover up. To close, tilt cover back to closed position and fasten the latches.



8-14 Periodic Maintenance and Adjustment

1. Sundry box cover

Engine Cover To Open/ Close

1. Remove two seats (see page 4-17)
2. Unscrew all the screws on the engine cover.
3. Pull the engine cover upward to open it.

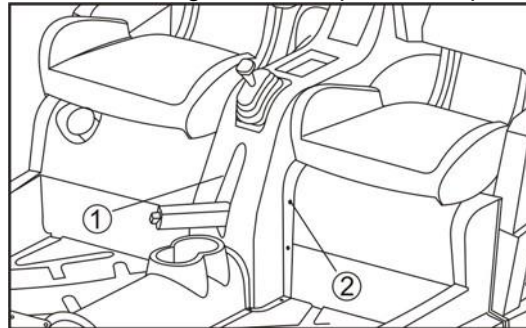

1. Engine cover 2. Screw (M6×12)

CAUTION:

When installing the engine cover, be sure not to pinch the cables or wires.

EFI system

EFI engine was completely different from the engine which uses carburetor, it consist of ECU, EFI-cables, sensors, actuators and other advanced components. As the following pictures:

1
2
3
4
5
6
7
8
9
10
11
12
13
14
15
16
17
18
19
20
21
22
23
24
25
26
27
28
29
30
31
32
33
34
35
36
37
38
39
40
41
42
43
44
45
46
47
48
49
50
51
52
53
54
55
56
57
58
59
60
61
62
63
64
65
66
67
68
69
70
71
72
73
74
75
76
77
78
79
80
81
82
83
84
85
86
87
88
89
90
91
92
93
94
95
96
97
98
99
100

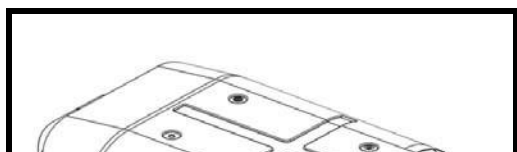

8-16 Periodic Maintenance and Adjustment

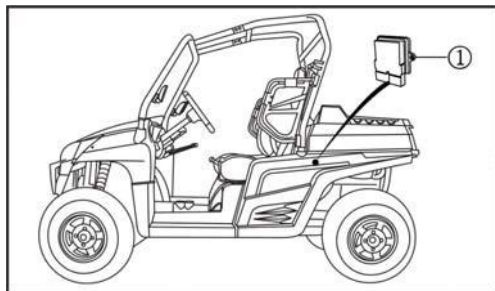

1. Oxygen sensor
2. Oxygen sensor threaded sleeve
3. Exhaust Pipe

1. ECU

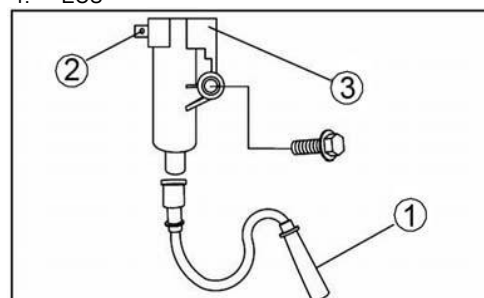

1. High voltage wire
2. Ignition signal plug

3. Ignition coil

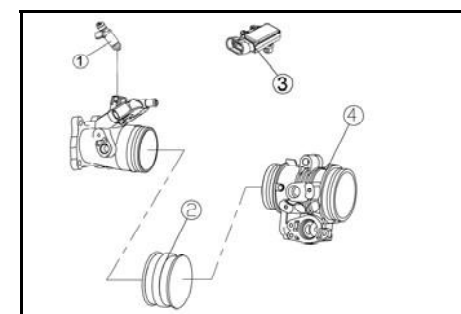

1. Fuel injector
2. Inlet bent pipe
3. Intake air temperature sensor/ pressure sensor
4. Ducting dampers



8-18 Periodic Maintenance and Adjustment

1. Water temperature sensor

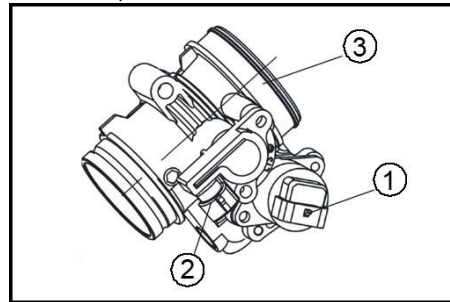

1. Idle speed stepper motor
2. Air damper degree sensor
3. Air damper

Air damper

For the purpose of adjustment of air intake volume.

Idle speed stepper motor To stabilize the idle speed **Fuel injector** Inject the fuel into the cylinder

Intake air temperature sensor

Inspect engine intake air temperature, according to the temperature, ECU will automatically adjust the fuel injection volume.

Air intake pipe pressure sensor

For testing the negative pressure of the air intake pipe, engine has the different working conditions, the 2 parameters- opening of air damper and pressure of air intake determine the engine's working condition, ECU will adjust the fuel injection volume according to different negative pressure and opening of air damper. Adjust the engine fuel injection volume can adjust the output power and output torque.

Water temperature sensor

For testing cooling water temperature, according to the temperature difference,

ECU will automatically revise fuel injection

8-20 Periodic Maintenance and Adjustment

volume, to ensure the smooth operation of the engine all the time.

Ignition signal

Ignition signal arising from the magneto to provide the ECU with correct ignition timing signal.

ECU

It is the core of EFI system, it used a specially designed micro computer chip as a controller , according to the information from sensors, has been calculated to ensure accurate control in different conditions from the nozzle of the fuel injection volume. To achieve fuel-efficient low emissions performance of the EFI engine.

EFI system inspection

If the EFI system has failure, the meter will display the appropriate failure code, you can

also use the special "EFI system failure diagnostic apparatus" for inspection, diagnostic apparatus can provide a more detailed failure information . Diagnostic apparatus equipped with its own user manual.

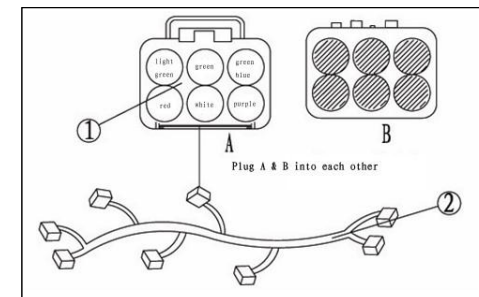

1. Diagnostic apparatus cable 2. EFI cables

Engine Oil and Oil Filter Cartridge

The engine oil level should be checked before each operation. In addition, the oil must be changed and the oil filter cartridge

replaced at the intervals specified in the

8-22 Periodic Maintenance and Adjustment

periodic maintenance and lubrication chart.

To Check Engine Oil Level

1. Place the vehicle on a level surface.
2. Remove the console.
3. Check the engine oil level on a cold engine.

NOTE: _____ If the engine was started before checking the oil level, be sure to warm up the engine sufficiently, and then wait at least ten minutes until the oil settles for an accurate reading.

4. Remove the engine oil filler cap and wipe off the dipstick with a clean rag.
5. Insert the dipstick in the oil filler hole (without screwing it in), and then remove it again to check the oil level.

NOTE: _____ The engine oil should be between the minimum and maximum level marks.

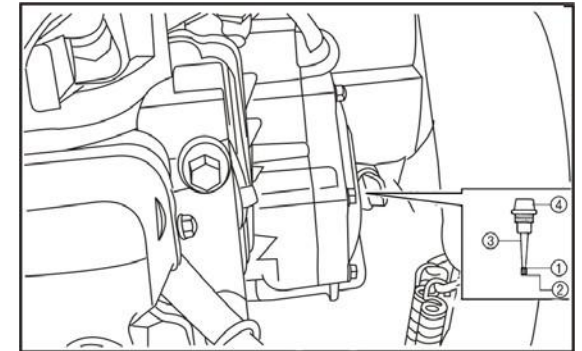

1. Maximum level mark
2. Minimum level mark
3. Dipstick
4. Engine oil filler cap

6. If the engine oil is at or below the minimum level mark, add sufficient oil of the recommended type to raise it to the correct level.
7. Insert the dipstick into the oil filler hole, and then tighten the oil filler cap.
8. Install the console.

To Change the Engine Oil (With or Without

8-24 Periodic Maintenance and Adjustment

Oil Filter Cartridge Replacement

1. Remove the console. Place an oil pan under the engine to collect the used oil, and then remove the engine oil filler cap.
2. Remove the engine oil drain bolt to drain the oil from the crankcase.

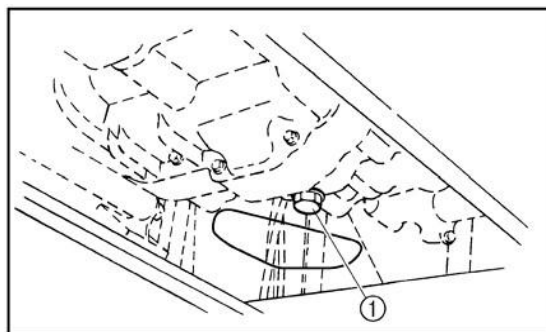

1. Engine oil drain bolt

NOTE:

Skip steps 4-6 if the oil filter cartridge is not being replaced.

3. Remove the oil filter cartridge with an oil filter wrench.

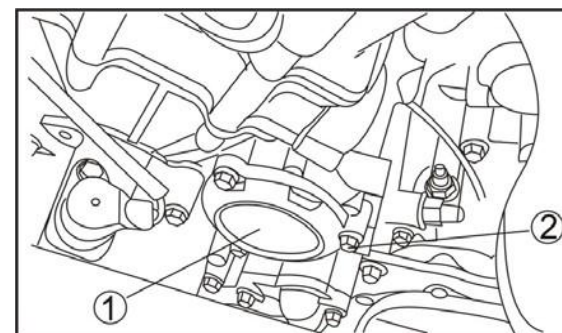

1. Oil filter cartridge 2. Oil filter bolt

NOTE: _____ An oil filter wrench is available at a nearby dealer.

4. Apply a light coat of engine oil to the O-ring of the new oil filter cartridge.

NOTE:

Make sure the O-ring is seated properly.

8-26 Periodic Maintenance and Adjustment

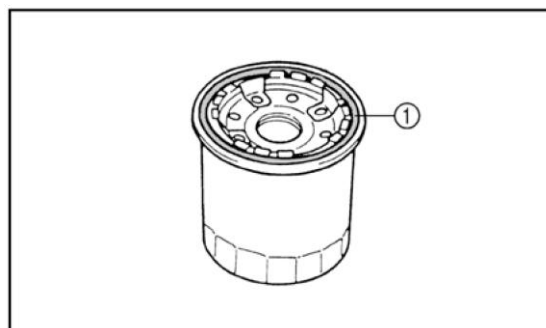

1. O-ring

5. Install the new oil filter cartridge with an oil filter wrench, and then tighten it to the specified torque with a torque wrench.

Tightening torque:

Oil filter cartridge: 17Nm
(1.7m·kgf, 12 ft-lbs)

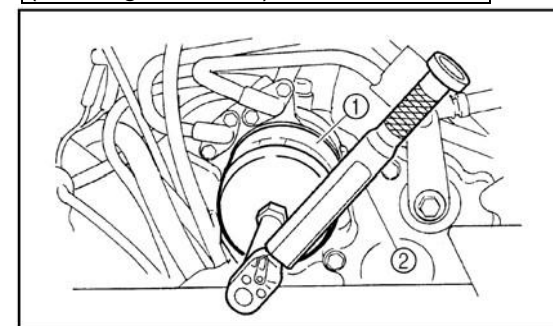

1. Oil filter cartridge 2. Torque wrench

6. Install the engine oil drain bolt, and then tighten it to the specified torque.

Tightening torque:
Engine oil drain bolt:
24Nm (2.4m·kgf, 17 ft-lbs)

7. Add the specified amount of

recommended engine oil, and then install the engine oil filler cap and tighten it.

Recommended engine oil: See page 10-2. Oil quantity: Without oil filter cartridge replacement: 1.05L (1.67 Imp qt, 2.01 US qt) With oil filter cartridge replacement: 2.0 L (1.76 Imp qt, 2.11 US qt)

the crankcase.

9. Start the engine, and then let it idle for several minutes while checking it for oil leakage. If oil is leaking, immediately turn the engine off and check for the cause.
10. Turn the engine off, wait at least ten minutes, and then check the oil level and correct it if necessary.
11. Install the console.

CAUTION:

- In order to prevent clutch slippage (since the engine oil also lubricates the clutch), do not mix any chemical additives. Do not use oils with a diesel specification of "CD" or oils of a higher quality than specified. In addition, do not use oils labeled "ENERGY CONSERVING II" or higher.
- Make sure that no foreign material enters

Final Gear Oil Checking the Final Gear Oil

8-30 Periodic Maintenance and Adjustment

Level

1. Place the vehicle on a level surface.
2. Remove the oil filler bolt, and then check the oil level in the final gear case.

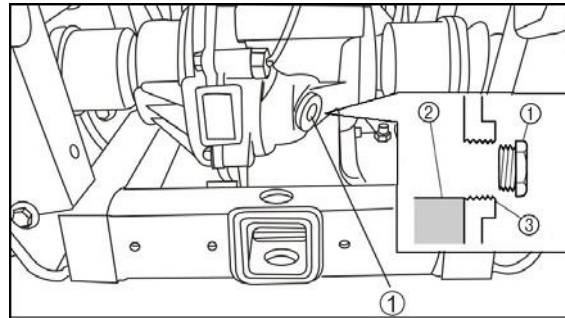

1. Oil filler bolt 2. Final gear oil
3. Correct oil level

NOTE:

The oil level should be at the brim of the filler hole.

3. If the oil is below the brim of the filler hole, add sufficient oil of the recommended type to raise it to the correct level.

CAUTION:

Be sure no foreign material enters the final gear case.

4. Install the oil filler bolt, and then tighten it to the specified torque.

Tightening torque:

Final gear oil filler bolt:
23 Nm (2.3 m-kgf, 16.3 ft-lbs)

Changing the Final Gear Oil

1. Place the vehicle on a level surface.

2. Place a container under the final gear

8-32 Periodic Maintenance and Adjustment

case to collect the used oil.

3. Remove the oil filler bolt and the drain bolt to drain the oil.

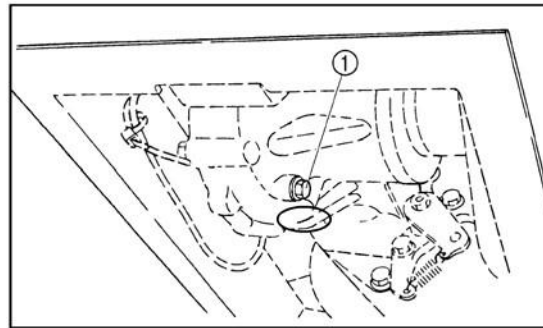

1. Final gear oil drain bolt

4. Install the drain bolt, and then tighten it to the specified torque

Tightening torque:
Final gear oil drain bolt:
20 Nm (2.0 m-kgf, 14 ft-lbs)

5. Add the recommended final gear oil up to the brim of the filler hole.

Recommended oil: SAE 80 API GL-4Hypoid gear oil
Oil quantity:
0.25 L (0.22 Imp qt, 0.26 US qt)

CAUTION:

Be sure no foreign material enters the final gear case.

6. Install the oil filler bolt, and then tighten it to the specified torque.

Tightening torque:
Final gear oil filler bolt:
23 Nm (2.3 m-kgf, 16.3 ft-lbs)

7. Check for oil leakage. If oil leakage is

found, check for the reason

Differential Gear Oil Checking the

Differential Gear Oil Level 1. Place the vehicle on a level surface.

2. Remove the differential gear oil filler bolt and check the oil level. It should be up to the brim of the filler hole. If the level is low, add sufficient oil of the recommended type to raise it to the specified level.

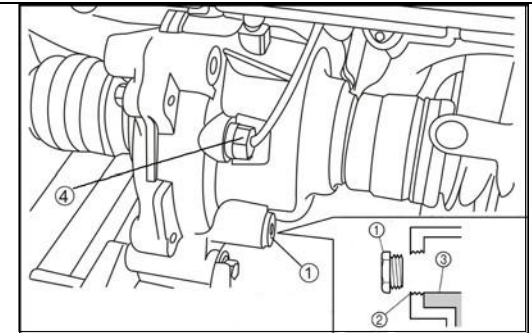

1. Speed sensor 2. Correct oil level
3. Differential gear oil 4. Oil level sensor

CAUTION:

1. To be sure no foreign material enters the differential gear case.
2. Please clean the sensor every 500km (310miles).

3. Install the differential gear oil filler bolt, and

then tighten it to the specified torque.

Tightening torque:
Differential gear oil filler bolt:
23Nm (2.3 m-kgf, 16.3 ft-lbs)

Changing the Differential Gear Oil

1. Place the vehicle on a level surface.
2. Place a container under the differential gear case to collect the used oil.
3. Remove the differential gear oil filler bolt and differential gear oil drain bolt to drain the oil.

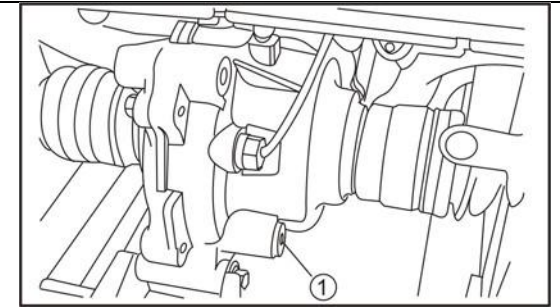

1. Differential gear oil drain bolt

4. Install the differential gear oil drain bolt, and tighten it to the specified torque.

Tightening torque:
Differential gear oil drain bolt:
23Nm (2.3 m-kgf, 16.3 ft-lbs)

5. Fill the differential gear case with the recommended oil.

Recommended oil:

SAE 80 API GL-5 Hypoid gear oil Oil
quantity:
0.1 L (0.085 Imp qt, 0.105 US qt)

CAUTION:

Be sure no foreign material enters the
differential gear case.

6. Install the differential gear oil filler bolt,
and then tighten it to the specified torque.

Tightening torque:
Differential gear oil filler bolt:
23Nm (2.3 m-kgf, 16.3 ft-lbs)

7. Check for oil leakage. If oil leakage is
found, check for the cause.

Coolant

The coolant level should be checked before
each ride.

Checking the Coolant Level

1. Place the vehicle on a level surface.
2. Open the hood. (See pages 8-6 for hood
opening and closing procedures.)
3. Check the coolant level in the coolant
reservoir when the engine is cold as the
coolant level varies with engine
temperature.

NOTE: _____ The coolant
should be between the minimum
and maximum level marks.

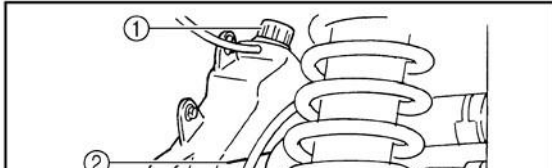

E
C
n
i
C
i
C
E
a
i
n
t
e
n
a

1. Coolant reservoir cap
2. Maximum level mark 3. Minimum level mark
4. If the coolant is at or below the minimum level mark, remove the reservoir cap, add coolant to the maximum level mark, install the reservoir cap, and then close the hood.

Coolant reservoir capacity (up to the maximum level mark):
0.627L(0.555Imp qt, 0.663US qt)

CAUTION:

Mix anti freeze with distilled water only. However, if distilled water is not available, soft water may be used for refilling.

Changing the Coolant

The coolant must be changed by a dealer at the intervals specified in the periodic maintenance and lubrication chart.

Recommended antifreeze:
High quality ethylene glycol antifreeze containing corrosion inhibitors for Aluminum engines.
Antifreeze and water mixing ratio: 1:1

Total amount:
1.32L (1.16 Imp qt, 1.40 US qt)
Coolant reservoir capacity
(up to the maximum level mark):
0.627 L (0.55 Imp qt, 0.65 US qt)

NOTE:

- Adding water instead of coolant lowers the antifreeze content of the coolant. If



water is used instead of coolant, have a

dealer check the antifreeze content of the coolant as soon as possible.

- The radiator fan is automatically switched on or off according to the coolant temperature in the radiator.

Axle Boots

Check the protective boots for holes or tears. If any damage is found, have them replaced

Periodic Maintenance and Adjustment 8-43

Removal

1. Remove hood (See pages 8-6)
2. Remove the spark plug cap.
3. Use the spark plug wrench in the tool kit to remove the spark plug as shown.

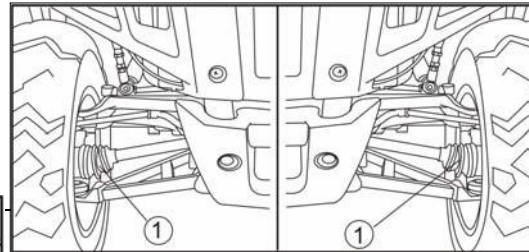
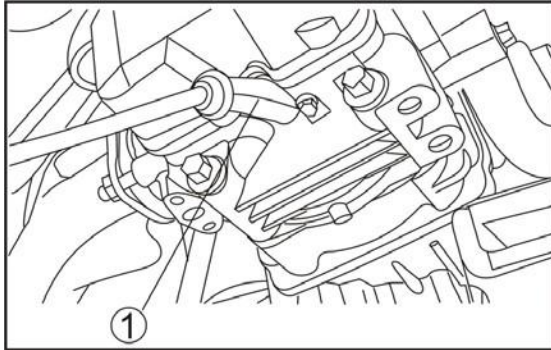

1. Front axle boot (×2 each side)

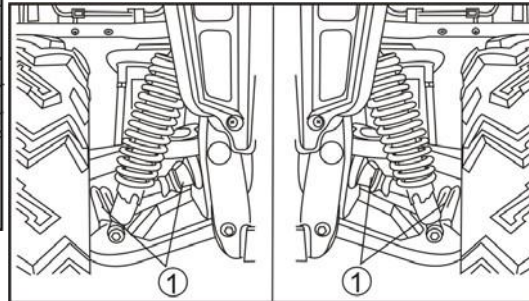

by a dealer.

1. Spark plug cap

Spark Plug Inspection

1. Rear axle boot (×2 each side)

8-44 Periodic Maintenance and Adjustment

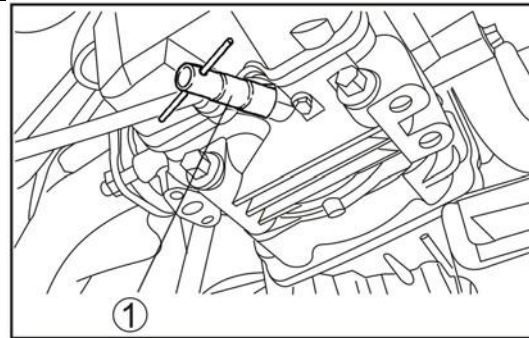

1. Spark plug wrench

Inspection

The spark plug is an important engine component and is easy to inspect. The condition of the spark plug can indicate the condition of the engine.

The ideal color of the porcelain insulator around the center electrode is a medium to light tan for a vehicle that is being ridden normally.

Do not attempt to diagnose such problems yourself.

Instead, take the vehicle to a dealer. You should periodically remove and inspect the spark plug because heat and deposits will cause the spark plug to slowly break down and erode. If electrode erosion becomes excessive, or if carbon and other deposits are excessive, you should replace the spark plug with the specified plug.

Specified spark plug:
DR8EA (NGK)

Installation

1. Measure the electrode gap with a wire thickness gauge and, if necessary, adjust the gap to specification.

l
c
n
i
c
i
c
l
a
i
n
t
e
n
a

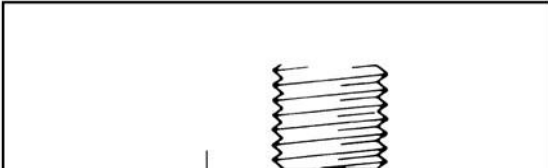

8-46 Periodic Maintenance and Adjustment

a. Spark plug gap

Spark plug gap:
0.6-0.7mm (0.023-0.027 in)

2. Clean the surface of the spark plug gasket and its mating surface, and then wipe off any grime from the spark plug threads.
3. Install the spark plug and tighten it to the specified torque.

Tightening torque:
Spark plug:
17.5 Nm(1.75 m-kgf, 12.4 ft-lbs)

NOTE: _____ If a torque wrench is not available when you are installing the spark plug, a good estimate of the correct torque is 1/4 to 1/2 turn past finger tight. Have the spark plug tightened

to the specified torque as soon as possible.

4. Install the spark plug cap.
5. Lower the cargo bed.

Cleaning the Air Filter Element

NOTE: _____ There is a check hose at the bottom of the air filter case. If dust or water collects in this hose, empty the hose and clean the air filter element and air filter case.

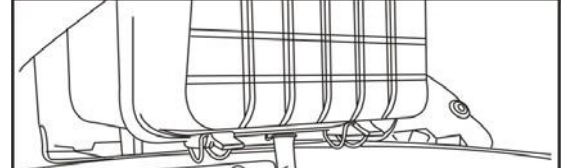

8-48 Periodic Maintenance and Adjustment

1. Air filter check hose

1. Remove the seats. (See pages 4-17 for seat removal and installation procedure.)
2. Remove the Engine cover. (See page 8-9 for Engine cover removal and installation procedure.)
3. Remove the connecting rubber tube between air cleaner and throttle valve and the screws fixing the air cleaner, and then remove the air cleaner.

frame.

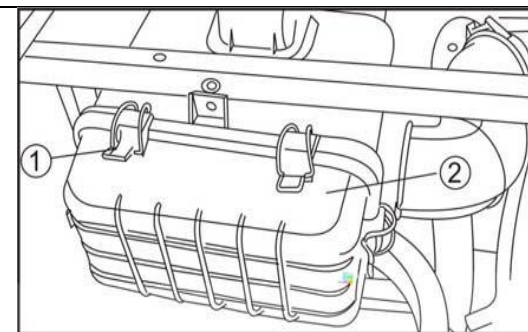

1. Holder (x6) 2. Air filter case cover

4. Remove the air filter element.
 5. Remove the sponge material from its
1. Air filter frame 2. Sponge material

⚠ WARNING

POTENTIAL HAZARD

Using low flash point solvents or gasoline to clean the sponge material.

WHAT CAN HAPPEN

Low flash point solvents or gasoline can catch fire or explode.

HOW TO AVOID THE HAZARD

Use parts cleaning solvent to clean the sponge material.

6. Wash the

sponge material gently but thoroughly in solvent.

3. Element retaining plate

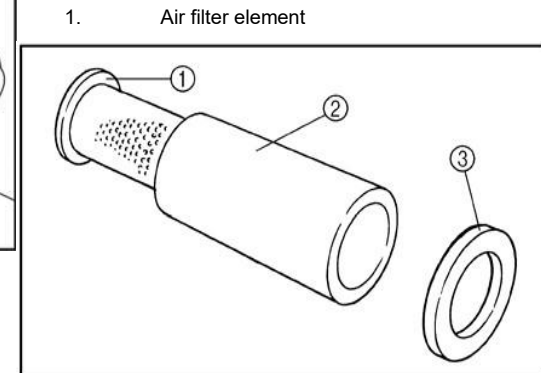
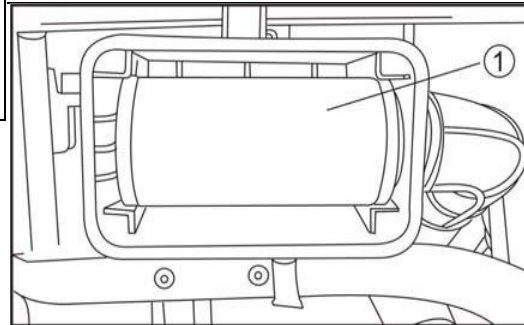

7. Squeeze the excess solvent out of the sponge material and let it dry.

CAUTION:

Do not twist the sponge material when squeezing it.

- 8. Inspect the sponge material and replace it if damaged.
- 9. Thoroughly apply foam air filter oil or other quality liquid foam air filter oil (not spray type) to the sponge material.

NOTE: _____ The sponge material should be wet but not

dripping.

- 10. Pull the sponge material over its frame.
- 11. Install the air filter element.
- 12. Install the air filter case cover and be sure the crankcase breather hose is connected.

8-50 Periodic Maintenance and Adjustment

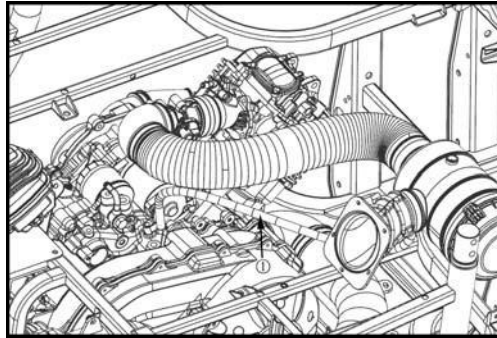

1. Crankcase breather hose

13. Install the engine cover.
14. Install the seats.

NOTE: _____ The air filter element should be cleaned every 20-40 hours. It should be cleaned and lubricated more often if the vehicle is operated in extremely dusty areas. Each time air filter element maintenance is performed, check the air inlet to the air filter case for obstructions. Check the air filter element rubber joint to the throttle valve and manifold fittings securely to avoid the possibility of unfiltered air entering the engine.

CAUTION:

Never operate the engine with the air filter element

8-52 Periodic Maintenance and Adjustment

removed. This will allow unfiltered air to enter, causing rapid engine wear and possible engine damage. Additionally, operation without the air filter element will affect throttle valve jetting with subsequent poor performance and possible engine overheating.

Cleaning the Spark Arrester

Be sure the exhaust pipe and muffler are cool before cleaning the spark arrester.

1. Remove the bolts.

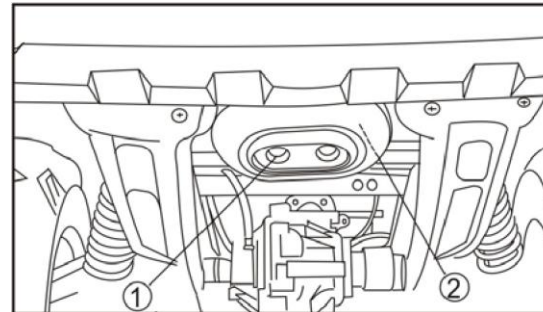

1. muffler

2. Spark Arrester

2. Remove the tailpipe by pulling it out of the muffler.
3. Tap the tailpipe lightly, and then use a wire brush to remove any carbon deposits from the spark arrester portion of the tailpipe and inside of the tailpipe housing.

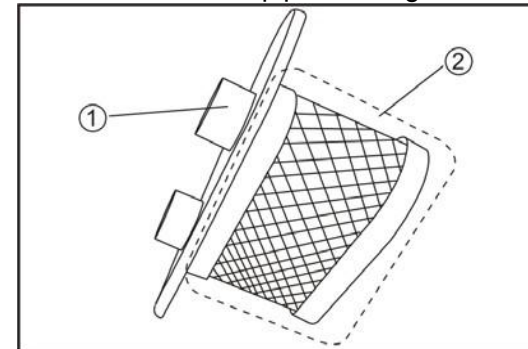

1. Tailpipe

2. Spark arrester

4. Insert the tailpipe into the muffler and align the bolt

holes.

5. Install the tailpipe by installing the bolts, and then tighten the bolts to the specified torque.

Tightening torque:

Tailpipe bolt:

12 Nm(1.2 m-kgf, 8.5 ft-lbs)

⚠ WARNING

POTENTIAL HAZARD

Improper cleaning of the spark arrester
Hot exhaust system.

WHAT CAN HAPPEN

Could injure the eyes.

Could cause burns.

Could cause carbon monoxide
poisoning, possibly leading to death.

Could start a fire.

HOW TO AVOID THE HAZARD

When cleaning the spark arrester

Always let the exhaust system cool
prior to touching exhaust components.

Do not start the engine when cleaning
the exhaust system.

Valve Clearance

The correct valve clearance changes with use, resulting in improper fuel-air supply or engine noise. To prevent this, the valve clearance must be adjusted regularly. This adjustment however, should be left to a professional service technician.

Front Brake Pad Check

Each brake pad is provided with wear indicator grooves, which allow you to check the brake pad wear without having to disassemble the brake system. To check the brake pad wear, check the wear indicator grooves. If a brake pad has worn to the point that the wear indicator grooves have almost disappeared, have a dealer replace the brake pads as a set.

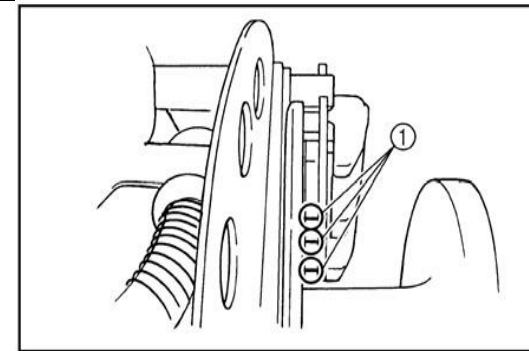

1. Brake pad wear indicator groove

NOTE: _____ The wheels need to be removed to check the brake pads. (See pages 8-39-8-40 for wheel removal and installation procedures.)

Rear brake pad check

8-58 Periodic Maintenance and Adjustment

Each brake pad is provided with wear indicator grooves, which allow you to check the brake pad wear without having to disassemble the brake system. To check the brake pad wear, check the wear indicator grooves. If a brake pad has worn to the point that the wear indicator grooves have almost disappeared, have a dealer replace the brake pads as a set.

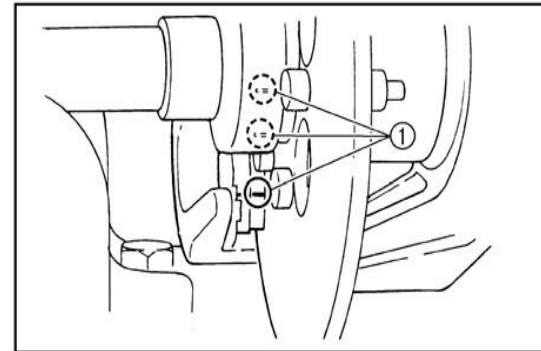

1. Brake pad wear indicator groove

Checking the Brake Fluid Level

Insufficient brake fluid may let air enter the brake system, possibly causing the brakes to become ineffective.

Before riding, check that the brake fluid is above the minimum level mark and replenish if necessary. A low brake fluid level may indicate worn brake pads and/or brake system leakage. If the brake fluid level is low, be sure to check the brake pads for wear and the brake system for leakage. The brake fluid reservoir is located under the hood. (See pages 8-6 for hood opening and closing procedure.)

l
c
n
i
c
i
c
l
a
i
n
t
e
n
a



8-60 Periodic Maintenance and Adjustment

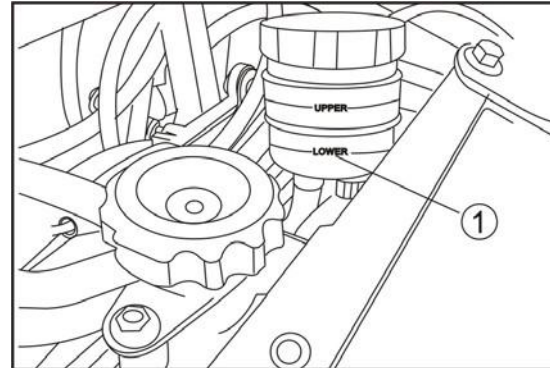

1. Minimum level mark

Observe these precautions:

- When checking the fluid level, make sure the top of the brake fluid reservoir is level.

- Use only the recommended quality brake fluid. Otherwise, the rubber seals may deteriorate, causing leakage and poor braking performance

Recommended brake fluid: DOT 3

- Refill with the same type of brake fluid. Mixing fluids may result a harmful chemical reaction and lead to poor braking performance.
- Be careful that water does not enter the brake fluid reservoir when refilling. Water will significantly lower the boiling point of the fluid and may result in vapor lock.

-
- Brake fluid may deteriorate painted surfaces or

plastic parts. Always clean up spilled fluid immediately.

- Have a dealer inspect the brake system if the brake fluid level goes down.

dealer replace the following components during periodic maintenance or when they are damaged or leaking.

- Replace the oil seals every two years.
- Replace the brake hoses every four years.

Checking the Brake Pedal

Have a dealer check the brakes at the intervals specified in the periodic maintenance and lubrication chart. There

Brake Fluid Replacement

Complete fluid replacement should be done only by trained service personnel. Have a

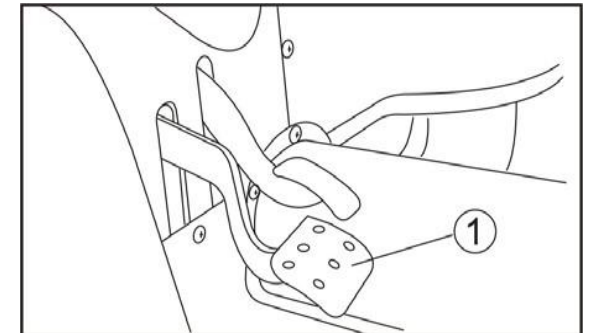

should be no free play in the brake pedal.

1. Brake pedal

8-64 Periodic Maintenance and Adjustment

The brakes should operate smoothly and there should be no brake drag. If the brakes feel soft or spongy, this could indicate air in the brake system. Have a dealer check the brake system if necessary.

Cable Inspection and Lubrication

⚠ WARNING

POTENTIAL HAZARD

Operating with improperly serviced or adjusted brakes.

WHAT CAN HAPPEN

You could lose braking ability, which could lead to an accident. **HOW TO AVOID THE HAZARD**

HOW TO AVOID THE HAZARD

After servicing:

- Make sure the brakes operate smoothly and that the brake pedal position is correct.
- Make sure the brakes do not drag.
- All air must be bled from the brake system.

Replacement of brake components requires professional knowledge. These procedures should be performed by a dealer.

⚠ WARNING

POTENTIAL HAZARD

Damaged control cables.

WHAT CAN HAPPEN

Corrosion can result when the outer covering of control cables becomes damaged. Cables can also become frayed or kinked. Operation of controls could be restricted, which could cause an accident or injury.

HOW TO AVOID THE HAZARD

Inspect cables frequently. Replace damaged cables.

Lubricate the inner cables and the cable ends. If the cables do not operate smoothly,

ask a dealer to replace them.

See page
10-2

**Brake Pedal
and
Accelerator**

**Pedal
Lubrication**

Lubricate
the pivoting
parts.

Recommen-
ded
lubricant:
Lithium-
based
grease
(all-
purpose
grease)



8-68 Periodic Maintenance and Adjustment

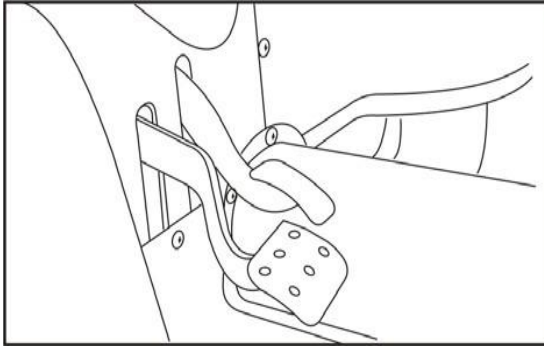

Rear Knuckle Upper and Lower Pivot Lubrication

Lubricate the knuckle upper and lower pivots with a grease gun.

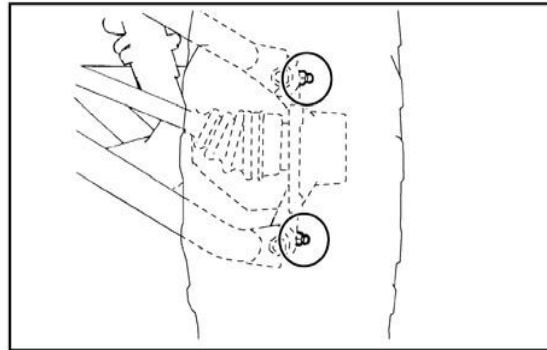

Recommended lubricant:
Lithium-based grease

Steering Shaft Lubrication

Lubricate the pivot points.

Recommended lubricant:
Lithium-based grease
(all-purpose grease)

Upper universal joint steering transmission shaft

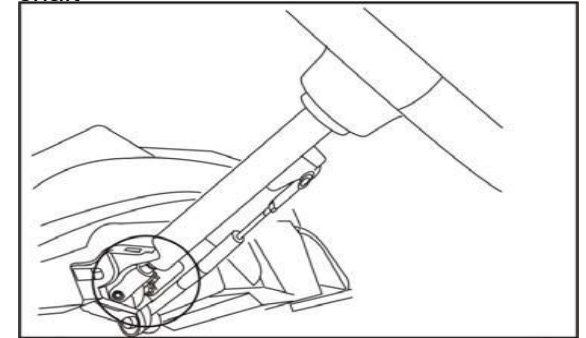

Lower universal joint steering transmission Front balance rod shaft

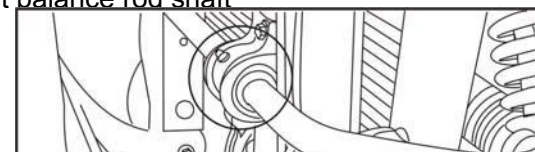
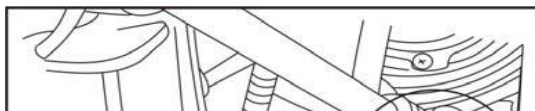

8-70 Periodic Maintenance and Adjustment

Rear balance rod

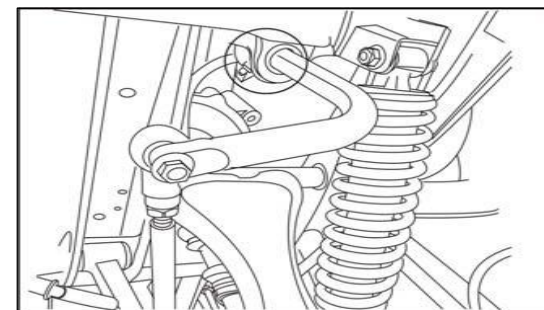

Wheel Removal

NOTE:

Loosen the wheel nuts.

● The arrow mark ⇄ on the tire must point

8-72 Periodic Maintenance and Adjustment

Elevate the vehicle and place a suitable

stand under the frame.

Remove the nuts from the wheel.

Remove the wheel.

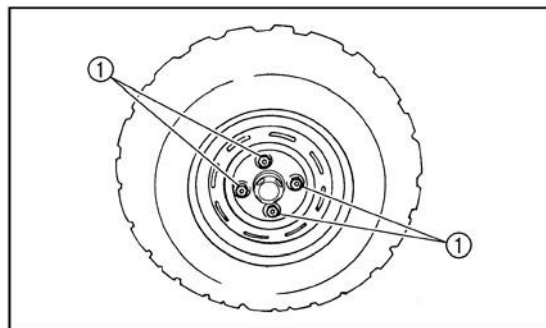

1. Nuts (x4)

toward the rotating direction of the wheel.

- Tapered nuts are used for both the front and rear wheels. Install the nut with its tapered side towards the wheel.

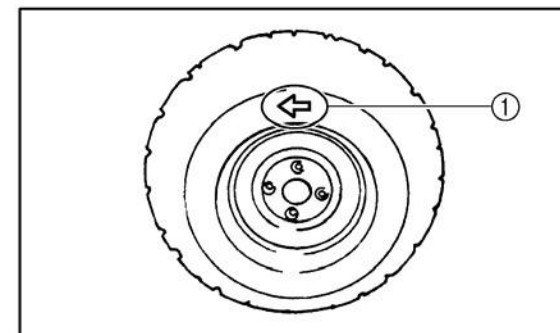

1. Arrow mark

Wheel Installation

8-74 Periodic Maintenance and Adjustment

1. Install the wheel and the nuts.

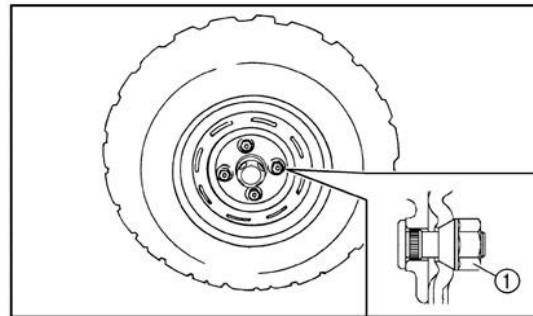

1. Tapered nut

2. Lower the vehicle so that the

3. Tighten the wheel nuts to the specified torque.

Wheel nut torque:

Front: 70Nm (7.0 m-kgf, 49.7 ft-lbs)

Rear: 70Nm (7.0 m-kgf, 49.7 ft-lbs)

in the battery. If the battery seems to have discharged, consult a dealer.

CAUTION:

Do not try to remove the sealing caps of the battery cells. You may damage the battery.

Battery

This vehicle is equipped with a sealed-type battery.

Therefore it is not necessary to check the electrolyte or add distilled water

⚠ WARNING

POTENTIAL HAZARD

Failure to handle batteries or battery electrolyte carefully.

WHAT CAN HAPPEN

You could be poisoned. You could be severely burned by the sulfuric acid in battery electrolyte. Batteries produce explosive gases.

HOW TO AVOID THE HAZARD

Avoid contact with skin, eyes or clothing. Always shield eyes when working near batteries. Keep out of reach of children.

Antidote:

EXTERNAL: Flush with water.

INTERNAL: Drink large quantities of water or milk. Follow with milk of magnesia, beaten egg or vegetable oil. Get prompt medical attention.

EYES: Flush with water for 15 minutes and get prompt medical attention. Keep batteries away from sparks, flames, cigarettes or other sources of ignition. Ventilate when charging or using in a closed space.

Battery Maintenance

1. When the vehicle is not used for a month or longer, remove the battery

and store it in a cool, dark place. Completely recharge the battery before reinstallation.

8-76 Periodic Maintenance and Adjustment

2. Always make sure the connections are correct when putting the battery back in the vehicle.

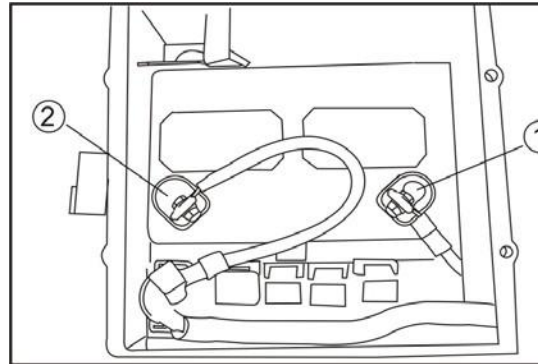

1. Negative battery lead 2. Positive battery lead

battery. Using a conventional battery charger may shorten the battery life.

Fuse Replacement

The main fuse and the fuse box are located under the seat.

If a fuse is blown, turn off the ignition switch and install a new fuse of the specified amperage.

If a fuse is blown, replace it as follows.

1. Remove the battery compartment cover by lifting it up and pulling it out.

CAUTION:

A special battery charger (constant voltage/ampere or constant voltage) is required for recharging a sealed-type

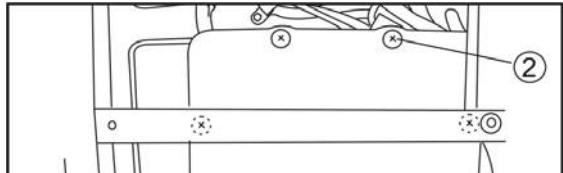

1. Battery compartment cover 2. Screw M6×8

2. Turn the key to “OFF” and turn off the electrical circuit in question.

CAUTION:

To prevent accidental short-circuiting, turn off the ignition switch when checking or replacing a fuse.

POTENTIAL HAZARD

Using an improper fuse

WHAT CAN HAPPEN

An improper fuse can cause damage to the electrical system, which could lead to a fire.

HOW TO AVOID THE HAZARD

Always use a fuse of the specified rating. Never use a material in place of the proper fuse.

⚠ WARNING

3. Remove the blown fuse, and then install a new fuse of the specified amperage.

Specified fuses:

8-80 Periodic Maintenance and Adjustment

Headlight horn fuse	15.0A 15.0A
ECU、 Pump fuse	15.0A
Auxiliary DC jack fuse	10.0 A
Signaling system fuse	10.0A
2WD/4WD fuse	10.0A
Rear bridge differential fuse	5.0A
ECU/Speedometer fuse	

Replacing Headlight Bulb

If a headlight bulb burns out, replace it as follows.

1. Lift the hood up. (See pages 8-6 for hood opening and closing procedures.)
2. Remove the cover at the rear of the headlight by pulling it off.

4. Turn the key to "ON" and turn on the electrical circuit in question to check if the device operates.
5. If the fuse immediately blows again, have a dealer check the electrical system.
6. Install the battery compartment cover.
7. Install the seat.

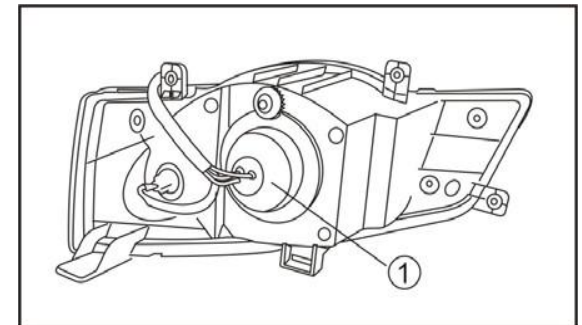

1. Cover at the rear of the headlight

3. Remove the headlight bulb holder

8-82 Periodic Maintenance and Adjustment

cover by pulling it off.

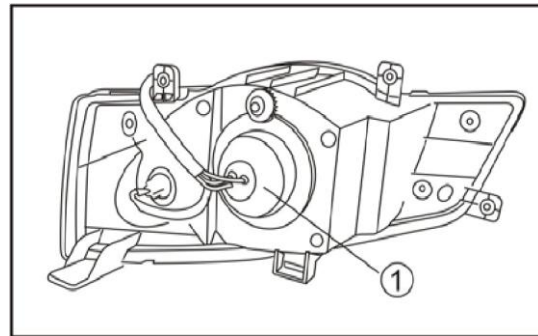

1. Headlight bulb holder cover

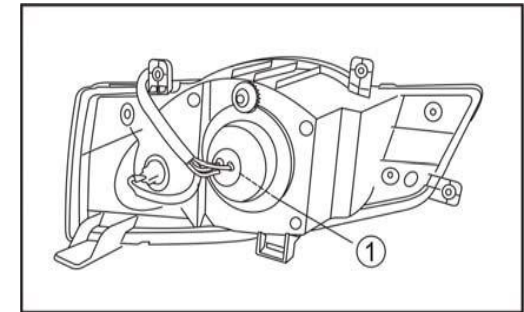

1. Headlight bulb holder

4. Remove the headlight bulb holder by pushing it in and turning it counter clockwise.
5. Remove the defective bulb by pulling it out.
6. Insert a new headlight bulb into the bulb holder by pushing it in.

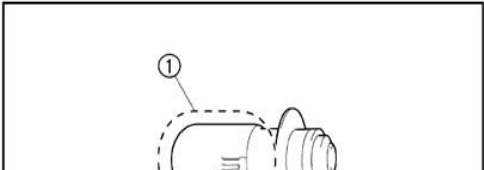

1. Do not touch the glass part of the bulb.

⚠ WARNING

POTENTIAL HAZARD

A headlight bulb is hot when it is on and immediately after it is turned off.

WHAT CAN HAPPEN

You can be burned, or a fire could start if the bulb touches something flammable.

HOW TO AVOID THE HAZARD

Wait for the bulb to cool before touching or removing it.

life will be adversely affected. Thoroughly clean off any dirt and fingerprints on the headlight bulb using a

7. Install the bulb holder by pushing it in and turning it clockwise.
8. Install the bulb holder cover and the cover at the rear of the headlight. **CAUTION:**

Make sure the headlight bulb holder cover is securely fitted over the bulb holder and seated properly.

9. Close the hood. 10. Adjust the headlight beam if necessary.

CAUTION:

Do not touch the glass part of the headlight bulb to keep it free from oil, otherwise the transparency of the glass, the luminosity of the bulb, and the bulb

Tail/Brake Light Bulb Replacement

If a tail/brake light bulb burns out, replace it as follows:

1. Remove panel A (if replacing the left tail/brake bulb) or panel B (if replacing the right



tail/brake bulb) by removing the quick

8-86 Periodic Maintenance and Adjustment

fasteners and bolts.

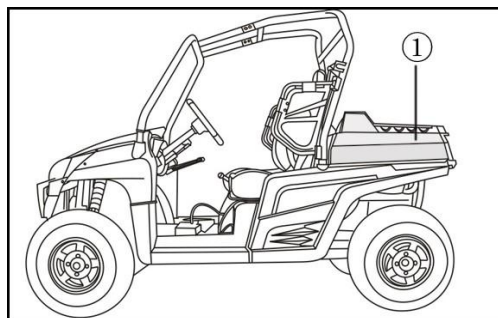

1. Panel A

1. Cargo bed

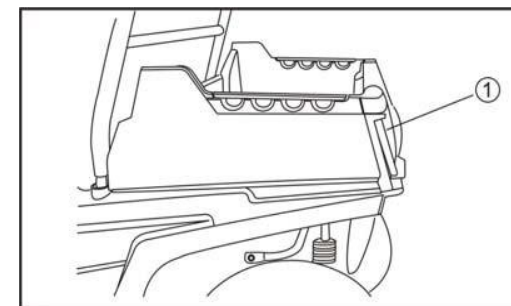

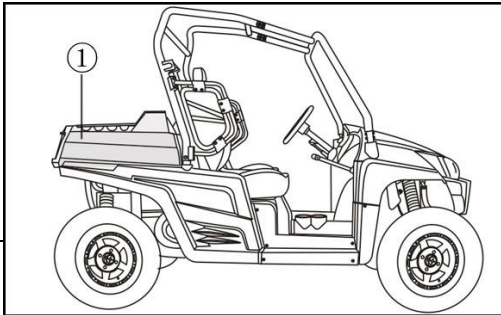

2. Remove the bulb holder (together with the bulb) by turning it counter clockwise.
3. Push the defective bulb in and turn it counter clockwise to remove it from the bulb holder.
4. Push a new bulb in and turn it clockwise to install in the bulb holder.
5. Install the bulb holder (together with the bulb) by turning it clockwise.

1. Panel B

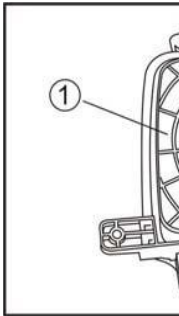

1. Tail/brake light bulb holder

6. Install the panel by installing the quick fasteners and bolts, and then tighten

the bolts to the specified torque.

Tightening torque:
 Panel bolt:
 6.5N·m
 (0.65 m-kgf, 4.7 ft-lbs)
Troubleshooting

Although vehicles receive a rigid inspection before shipment from the factory, trouble may occur during operation. Any problem in the fuel, compression, or ignition systems can cause poor starting and loss of power. The troubleshooting chart describes a quick, easy procedure for making checks. If your vehicle requires any repair, take it to a dealer. The skilled technicians at a dealership have the tools, experience, and know how to properly service your vehicle. Imitation parts may look like original parts,

8-88 Periodic Maintenance and Adjustment

but they are often inferior. Consequently, they have a shorter service life and can lead to expensive

⚠ WARNING

POTENTIAL HAZARD

Checking the fuel system while smoking or near an open flame.

WHAT CAN HAPPEN

Fuel can ignite or explode, causing severe injury or property damage.

HOW TO AVOID THE HAZARD

Do not smoke when checking the fuel system. Make sure there are no open flames or sparks in the area, including pilot lights from water heaters or furnaces.

Check and solution to Common Problems in Vehicle

Here you can see some tables on the common problems which may come up when you are driving a UTV, which will help to solve these problems.

To repair a UTV requires technical skills, if you cannot fix it up yourself, please contact your dealer.

Table1:Check and Solution of Common Problems in Appearance parts and impact fittings.

8-90 Periodic Maintenance and Adjustment

S/N	Problems	Solutions
1	Covers are cracked up when go crashing the field.	1. Covers are cracked up when go crashing the field.
		2.Change for new plastic covers.
		3.Re-paste the stickers and re-rivet the warning lables.
2	Vehicle's bottom protection plate is damaged by prominence on ground.	1.Check if the reduction gear box and differential in front and rear bridge are damaged or if there is any oil leakage.
		2.Check if the bottom of engine is damaged or if there is any oil leakage.
		3.Change for new bottom protection plate.

Table 2: Check and Solution of Common Problems in Brake System .

S/N	Problems	Solutions
1	Brake system is locked up.	1.Check if the handle of parking brake ruturn to its position.
		2.Check if the brake discs are deformed.

l
c
n
i
c
i
c
l
a
i
n
t
e
n
a



		3. Check if the calipers' hydraulic cylinders get stuck, or the
--	--	-----------------------------------------------------------------

8-92 Periodic Maintenance and Adjustment

		fixing parts of calipers are deformed.
2	Brake performance goes down.	1. Check if the brake disc are over-worn.
		2. Check if the brake block in calipers are over-worn, or contaminated by stuffs which can reduce friction.
		3. Check if there is any leakage in brake system's oil lines or conjunctions.
		4. Check if the post rod in brake master cylinder is deformed.
		5. Check if there is any air go into the oil lines, and drain the air with special equipment.
		6. Check if the remain oil in master cylinders of front and rear brake is still above the lowest level.
3	Front or rear brake system makes affricate noise, or the brake discs go.	1. Check if the brake discs are deformed.
		2. Check if the calipers' hydraulic cylinders get stuck, or the fixing parts of calipers are deformed.

		1.Check if left & right brake force' deviation of front brake is
--	--	------------------------------------------------------------------

8-94 Periodic Maintenance and Adjustment

4	Vehicle go deflected when braked at high speed.	with specified limit.
		2.Check if the brake force of front brake go down, which cause the rear wheels are locked up before the front wheels when braked.
		3.Check if spring force's deviation of shock absorbers in front left & right suspension are within specified limit.
		4.Check if the damper rubber sleeves connecting front suspension rock and frame are damaged.

l
c
n
i
c
i
c
l
a
i
n
t
e
n
a



8-96 Periodic Maintenance and Adjustment

Table 3: Check and Solution of Common Problems in Electrical System

S/N	Problems	Solutions
1	Lamps don't work.	1.check if the headlight switch functions well.
		2.Check if the wires are broken.
		3.Check if the lamps or bulbs are broken.
2	Vehicle cannot go into 4 drive mode.	1.Check if the control switch on meter board works well.
		2.Check if the differential lock control magneto plug in rear bridge reduction gear box are broken.
		3.Check if the wire is broken.
3	Rear differential won't work.	1.Check if the control switch on meter board works well.
3	Rear differential won't work.	2.Check if the differential lock control magneto plug in rear bridge reduction gear box are broken.
		3.Check if the wire is broken.
4	Meter display abnormally.	1.Check if the sensor is broken.
		2.Check if the meter is broken.
		3.Check if the surface of speed sensor is contaminated with iron dust.
5		1.Check if the switch is broken.

| |

2. Check if the wire is broken.

8-98 Periodic Maintenance and Adjustment

	Start switch on meter board won't work	3. Check if the ECU in electrical injection system is broken.
--	----------------------------------------	---------------------------------------------------------------

Table 4: Check and Solution of Common Problems in Running System

S/N	Problems	Solutions
1	Swing clearance of steering wheel is too big	1. Check the fix screws connecting steering rod to steering stem and knuckle to find out if they are loose or broken 2. Check the ball studs on the ends of steering rod to find out if they are broken 3. Check the clearance between gears of steering machine if it is too big.
2	Front wheels shake seriously in running.	1. Check the bearings in knuckles if they are broken.
2	Front wheels shake seriously in running.	2. Check the main ball pins to find out if they are broken. 3. Check the lock screws of front wheels and axles to find out if they are loose or broken. 4. Check the splined hold of front wheel hubs and spline shaft of front wheel axles to find out if they are worn or broken.

5. Check rubber bushes between the front suspension rocks and

8-100 Periodic Maintenance and Adjustment

		frame to find out if they are broken.
3	Rear wheels shake seriously in running.	1.Check the bearing in rear bridge bearing seat to find out if they are broken.
		2.Check the sliding bearing connecting rear bridge and rocks to find out if they are worn or loose.
		3.Check the splined hold of rear wheel hubs and spline shaft of rear wheel axles to find out if they are worn or broken.
		4.Check the lock screws of rear wheels and axles to find out if they are loose or broken.
		5.Check rubber bushes between the rear suspension rock and frame to find out if they are broken.
4	Wheels jump seriously in running.	1.Check if the rims are deformed.
		2.Check if the rear wheel axles are bent.
		3.Check if the tires are worn or deformed.
5	Shock absorbers become soft and not	1.Check if overloaded.
		2.Check if the springs are too soft after long time running.

comfortable in 3. Check if the shock absorbers lose their damping force in their

8-102 Periodic Maintenance and Adjustment

	running.	travel.
6	Front bridge makes noise in running.	1.Check if the spline shaft of intermediate driving shaft is broken.
		2.Check if the spline shaft in left & right drive shafts of front & rear bridges are broken.
		3.Check if the gears in rear bridge reduction gear box and differential are over worn.
		4.Check the dust cover of constant velocity universal joint in right & left drive shafts.

Table5: Check and Solution of Common Problems in Engine System

S/N	Problems	Solutions
1	Idle speed is not stable	1.Check the battery voltage for Within specified value
		2.Check the rectifier output voltage for within specified value
		3.Check MEUI for failure
2	Power performance is falling	1.Check if there is one cylinder not working.
		2.Check gasoline nozzle for block
		3.Check and clean core of air cleaner

	4. Check muffler for partly block and clean spark arrestor
--	------------------------------------------------------------

8-104 Periodic Maintenance and Adjustment

3	Popping in engine	1. Check air cleaner and admission line for leak.
		2. Check the connection joint of exhaust pipe with engine or muffler for leak
		3. Check the grade of gasoline to see if it's too low
4	Engine is difficult to start at low temperature	1. Check if the battery voltage goes down when temperature goes down
		2. If the temperature is under -18°C , have the vehicle placed in warmer place for start.
5	Coolant boils	1. Check the cooling fin of radiator for blocked by soil or dirt
		2. Check the speed sensor of radiator for damage and Check fan for failure
		3. Check if antifreeze can meet the requirement stated in the owner manual.
		4. Check the coolant loop for mixed with air
6	Engine can not start	1. Check the battery ,which with low electricity may cause the motor failure
		2. Check the starting motor for damage

| |

3.Check if MEUI can work in good condition

8-106 Periodic Maintenance and Adjustment

		4. Check if the ignition loop can work in good condition
		5. Check if the spark plug is carbon deposition or burned
		6. Check if the ignition signal is in good condition
		7. Check if the air cleaner is blocked
		8. Check if the oil circuit is smooth
		9. Check if the exhaust system is blocked

WARNING

POTENTIAL HAZARD

Removing the radiator cap when the engine and radiator are still hot.

WHAT CAN HAPPEN

You could be burned by hot fluid and steam blown out under pressure.

HOW TO AVOID THE HAZARD

Wait for the engine to cool before removing the radiator cap. Always use a thick rag over the cap. Allow any remaining pressure to escape before completely removing the cap.

NOTE:

8-108 Periodic Maintenance and Adjustment

If it is difficult to get the recommended coolant, tap water can be temporarily used, provided that it is changed to the recommended coolant as soon as poss

Cleaning

Frequent, thorough cleaning of your vehicle will not only enhance its appearance but will improve its general performance and extend the useful life of many components.

1. Before cleaning the vehicle:
 - a. Block off the end of the exhaust pipe to

prevent water entry. A plastic bag and strong rubber band may be used.

- b. Make sure the spark plug and all filler caps are properly installed.
2. If the engine case is excessively greasy, apply

degreaser with a paint brush.

Do not apply degreaser to the wheel axles.

3. Rinse the dirt and degreaser off with a garden hose. Use only enough

9-2 Cleaning and Storage

cloth.

pressure to do the job.

Cleaning and Storage 9-1

CAUTION:

Excessive water pressure may cause water seepage and deterioration of wheel bearings, brakes, transmission seals and electrical devices. Many expensive repair bills have resulted from improper high pressure detergent applications such as those available in coin-operated car washes.

4. Once the majority of the dirt has been hosed off, wash all surfaces with warm water and mild, detergent-type soap. An old toothbrush or bottle brush is handy for hard-to-get-at places.
5. Rinse the vehicle off immediately with clean water and dry all surfaces with a chamois, clean towel or soft absorbent

⚠ WARNING

POTENTIAL HAZARD

Operation with wet brakes after washing.

WHAT CAN HAPPEN

Wet brakes may have reduced stopping ability, increasing the chance of an accident.

HOW TO AVOID THE HAZARD

Test the brakes after washing. Apply the brakes several times at slow speeds to let friction dry out the linings.

6. Clean the seats with vinyl upholstery cleaner to keep the cover pliable and glossy.
7. Automotive type wax may be applied to all painted and chrome plated surfaces. Avoid combination cleaner-waxes. Many contain abrasives which may scratch the paint or protective finish. When finished, start the engine and let it idle for several minutes.

Storage

Long term storage (60 days or more) of your vehicle will require some preventive procedures to guard against deterioration. After thoroughly cleaning the vehicle,

prepare for storage as follows:

1. Fill the fuel tank with fresh fuel and add the specified amount of Fuel Stabilizer and Conditioner or equivalent

product.
Operate
the
vehicle
for at
least 5

Cleaning and Storage 9-3

minutes
to
distribute
treated
fuel
through
the fuel
system.

Specified amount:

1 oz of stabilizer to each gallon of fuel (or
7.5 ml of stabilizer to each liter of fuel)

2. This will
help
prevent
fuel
deposits
from
building
up.

NOTE: _____ Use of fuel stabilizer and conditioner eliminates the need to drain the fuel system. Consult a dealer if the fuel system needs to

be drained instead.

3. Remove the spark plug, pour about one tablespoon of SAE 10W30 or 20W40 motor oil in the spark plug. Ground the spark plug wire and turn the engine over several times to coat the cylinder wall with oil.

4. Lubricate all control cables.

5. Block up the frame to raise all wheels off the ground.

9-4 Cleaning and Storage

6. Tie a plastic bag over the exhaust pipe outlet to prevent moisture from entering.
7. If storing in a humid or salty atmosphere, coat all exposed metal surfaces with a light film of oil. Do not apply oil to any rubber parts or the seat covers.
8. Remove the battery and charge it. Store it in a dry place and recharge it once a month. Do not store the battery in an

excessively warm or cold place (less than 0°C (32°F) or more than 30°C (86°F)).

NOTE: _____ Make any necessary repairs before storing the vehicle.

Specification 10-1

Model	HS550UTV-3/HS550UTV-4
Dimensions: Overall length Overall width Overall height Seat height Wheelbase Ground clearance Minimum turning radius	2700mm (106.3 in) 1360mm (53.5 in) for HS550UTV-3 1520mm (59.8 in) for HS550UTV-4 1840mm (72.4 in) 425mm (16.7 in) 1940mm (76.4 in) 260 mm (10.2 in) 5000 mm (196.9 in)
Basic weight With oil and full fuel tank	720 kg (1587lb)
Engine: Engine type Cylinder arrangement Displacement Bore × stroke Compression ratio Starting system Lubrication system	Liquid-cooled 4-stroke, SOHC Forward-inclined single cylinder 546 cm ³ 91mm×84mm 9.6:1 Electric starter Wet sump

Model	HS550UTV-3/HS550UTV-4
-------	-----------------------

10-2 Specifications

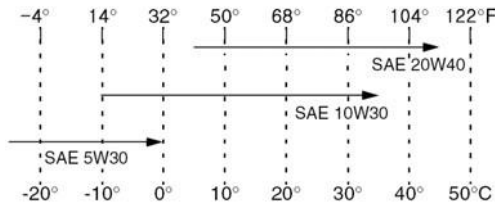
<p>Starting system Lubrication system</p> <p>Engine oil: Type</p> <p>Recommended engine oil classification</p> <p>Quantity: Without oil filter cartridge replacement With oil filter cartridge replacement</p>	 <p>API service SG type or higher, JASO standard MA</p> <p>CAUTION: _____ In order to prevent clutch slippage (since the engine oil also lubricates the clutch), do not mix any chemical additives. Do not use oils with a diesel specification of “CD” or oils of a higher quality than specified. In addition, do not use oils labeled “ENERGY CONSERVING II” or higher.</p> <p>1.90L (2.01 qt) 2.10L (2.22 qt)</p>
--------------------------------------------------------------------------------------------------------------------------------------------------------------------------------------------------------------------------------	---------------------------------------------------------------------------------------------------------------------------------------------------------------------------------------------------------------------------------------------------------------------------------------------------------------------------------------------------------------------------------------------------------------------------------------------------------------------------------------------------------------------

Model	HS550UTV-3/HS550UTV-4
<p>Final gear case oil: Type Quantity:</p>	<p>SAE80 API GL-4 Hypoid gear oil 0.40L (0.35 Imp qt, 0.41 US qt)</p>

Specification 10-3

Differential gear case oil: Type Quantity:	SAE80 API GL-5 Hypoid gear oil 0.10L (0.08 Imp qt, 0.1 US qt)
Radiator capacity (including all routes):	2.50L (2.20 Imp qt, 2.64 US qt)
Air filter:	Wet element
Fuel: Type Fuel tank capacity	Unleaded gasoline only 28.0L (7.40 US gal)
Throttle valve: Type/quantity	D46-U/1
Spark plug: Type Spark plug gap	DR8EA 0.6-0.7 mm (0.023-0.027 in)
Clutch type:	Wet, centrifugal automatic

Model	HS550UTV-3/HS550UTV-4
Transmission: Primary reduction system Secondary reduction system Transmission type Operation	CVT-belt Shaft drive CVT-belt automatic Right hand operation

10-4 Specifications

Tire: Type Size	Front Rear	Tubeless 26×9-14 26×11-14
Brakes: System Type Operation	Front Rear	Front and rear unified Dual disc brake Dual disc brake Foot operation
Suspension: Front/ Rear suspension		Double wishbone
Shock absorber: Front shock absorber Rear shock absorber		Coil spring/oil damper Coil spring/oil damper

Model	HS550UTV-3/HS550UTV-4
Wheel travel: Front wheel travel Rear wheel travel	130mm (5.12 in) 150mm (5.91in)
Electrical: Ignition system Generator system	ECU AC magneto
Battery type Battery capacity	U1L-11 or GSU1-9 12V32.0Ah or 12V30.0Ah

Specification 10-5

Bulb voltage, wattage × quantity: Headlight Tail/brake light Front/Rear turning light License light	12V35.0W/35.0W × 2 12V5.0W/21.0W × 2 12V10.0W/10.0W × 2 12V3.0W
Indicator lights: Neutral indicator light Reverse indicator light Coolant temperature warning light Parking brake indicator light Diff-lock indicator	LED LED LED LED LED
Model	HS550UTV-3/HS550UTV-4
On-Command differential gear lock indicator light High-range indicator light Low-range indicator light	LED LED LED
Specified fuses: Headlight horn fuse ECU, Pump fuse Auxiliary DC jack fuse Signaling system fuse 2WD/4WD fuse Rear bridge differential fuse ECU/Speedometer fuse	15.0A 15.0A 15.0A 10.0 A 10.0A 10.0A 5.0A

Fault Code of Electronic Injection System 11-1
Fault Code of Electronic Injection System

DTC Number	DTC Description	Related Calibration	HEX	DEC
P0107	MAP Circuit Low Voltage or Open	KsDGDM_MAP_ShortLow	107	263
P0108	MAP Circuit High Voltage	KsDGDM_MAP_ShortHigh	108	264
P0112	IAT Circuit Low Voltage	KsDGDM_IAT_ShortLow	112	274
P0113	IAT Circuit High Voltage or Open	KsDGDM_IAT_ShortHigh	113	275
P0117	Coolant/Oil Temperature Sensor Circuit Low Voltage	KsDGDM_CoolantShortLow	117	279
P0118	Coolant/Oil Temperature Sensor Circuit High Voltage or Open	KsDGDM_CoolantShortHigh	118	280
P0122	TPS Circuit Low Voltage or Open	KsDGDM_TPS_ShortLow	122	290
P0123	TPS Circuit High Voltage	KsDGDM_TPS_ShortHigh	123	291

P0131	O2S 1 Circuit Low Voltage	KsDGDM_O2_1_ShortLow	131	305
-------	---------------------------	----------------------	-----	-----

11-2 Fault Code of Electronic Injection System

P0132	O2S 1 Circuit High Voltage	KsDGDM_O2_1_ShortHigh	132	306
P0031	O2S Heater Circuit High Voltage	KsDGDM_O2_HeaterShortHigh	31	49
P0032	O2S Heater Circuit Low Voltage	KsDGDM_O2_HeaterShortLow	32	50
P0201	Injector 1 Circuit Malfunction	KsDGDM_INJ_CYL_A_Fault	201	513
P0202	Injector 2 Circuit Malfunction	KsDGDM_INJ_CYL_B_Fault	202	514
P0230	FPR Coil Circuit Low Voltage or Open	KsDGDM_FPP_CircuitShortLow	230	560
P0232	FPR Coil Circuit High Voltage	KsDGDM_FPP_CircuitShortHigh	232	562
P0336	CKP Sensor Noisy Signal	KsDGDM_CrankNoisySignal	336	822
P0337	CKP Sensor No Signal	KsDGDM_CrankNoSignal	337	823

P0351	Cylinder 1 Ignition Coil Malfunction	KsDGDM_EST_A_Fault	351	849
P0352	Cylinder 2 Ignition Coil Malfunction	KsDGDM_EST_B_Fault	352	850
P0505	Idle Speed Control Error	KsDGDM_IdleControl	505	1285
P0562	System Voltage Low	KsDGDM_SysVoltLow	562	1378

Fault Code of Electronic Injection System 11-3

P0563	System Voltage High	KsDGDM_SysVoltHigh	563	1379
P0650	MIL Circuit Malfunction	KsDGDM_MIL_Circuit	650	1616
P1693	Tachometer Circuit Low Voltage	KsDGDM_TAC_Circuit_Low	1693	5779
P1694	Tachometer Circuit High Voltage	KsDGDM_TAC_Circuit_High	1694	5780
P0137	O2S 2 Circuit Low Voltage	KsDGDM_O2_2_ShortLow	137	311
P0138	O2S 2 Circuit High Voltage	KsDGDM_O2_2_ShortHigh	138	312
P0038	O2S Heater 2 Circuit High Voltage	KsDGDM_O2_HeaterShortHigh	38	56

P0037	O2S Heater 2 Circuit Low Voltage	KsDGDM_O2_HeaterShortLow	37	55
P0500	VSS No Signal	KsDGDM_VSS_NoSignal	500	1280
P0850	Park Neutral Switch Error	KsDGDM_ParkNeutralSwitch	850	2128
P0445	CCP short to high	KsDGDM_CCP_CircuitShortHigh	445	1093
P0444	CCP short to low/open	KsDGDM_CCP_CircuitShortLow	444	1092
P0171	BLM Max Adapt(Kohler Special)	KsFDIAG_BLM_MaxAdapt	171	369
P0172	BLM Min Adapt(Kohler Special)	KsFDIAG_BLM_MinAdapt	172	370
P0174	PE System Lean(Kohler Special)	KsFDIAG_PESystLean	174	372

Hisun Motors Corp., U.S.A. Emission Control System Warranty Statement

YOUR WARRANTY RIGHTS AND OBLIGATIONS

The U.S. Environmental Protection Agency and **Hisun Motors Corp., U.S.A.**

(hereinafter "**HISUN**") are pleased to explain the emission control system warranty on your Off-Road vehicle. New off-road motor vehicles must be designed, built and equipped to meet U.S. EPA Federal and California anti-smog standards. HISUN must warrant the emission control system on your vehicle for 5,000 km, or at least 30 months, whichever comes first, provided that there has been no abuse, neglect or improper maintenance of your vehicle. This off-road vehicle was designed to meet the emission standards for 10,000 km, or five years, whichever comes first.

Your emission control system warranty covers components whose failure would increase an engine's emissions of any regulated pollutant

Where a warrantable condition exists, HISUN will repair your vehicle at no cost to you, including diagnosis, parts and labor.

If an emission-related part on your vehicle is defective, the part will be repaired or
Hisun Motors Corp., U.S.A. Emission Control System Warranty Statement

replaced by HISUN. This is your EMISSION CONTROL SYSTEM WARRANTY.

NOTICE! Use of this vehicle in any type of competitive event completely and absolutely voids this and all other warranties offered by HISUN.

OWNER'S WARRANTY RESPONSIBILITIES

As the vehicle owner, you are responsible for the performance of the required maintenance listed in your owner's manual. HISUN recommends that you retain all receipts covering maintenance on your vehicle, but HISUN cannot deny warranty solely for the lack of receipts or for your failure to ensure the performance of all scheduled maintenance.

You are responsible for presenting your vehicle to the HISUN dealer as soon as a problem exists. The warranty repairs should be completed in a reasonable amount of time, not to exceed 30 days.

As the vehicle owner, you should be aware that HISUN may deny your warranty
Hisun Motors Corp., U.S.A. Emission Control System Warranty Statement

coverage if your vehicle or a part has failed due to abuse, neglect, improper maintenance or unapproved modifications.

If you use your vehicle in any type of competitive event, this warranty is immediately and completely void.

If you have any questions regarding your warranty rights and responsibilities, you should contact Hisun Motors Corp., U.S.A., 310 E, University Drive, McKinney, TX 75069 (Phone: 972-446-0760 or Toll Free: 877-838-6188), or the U.S. Environmental Protection Agency at 2000 Traverwood Drive, Ann Arbor, MI 48105.



Hisun Motors Corp., U.S.A. Limited Warranty on Emission Control System

YOUR WARRANTY RIGHTS AND OBLIGATIONS

Hisun Motors Corp., U.S.A. warrants that each new off-road vehicle:

A. is designed, built and equipped so as to conform at the time of initial retail purchase with all applicable regulations of the United States Environmental Protection Agency, and

B. is free from defects in material and workmanship which cause such vehicle to fail to conform to applicable regulations of the United States Environmental Protection Agency for the periods specified above.

I. **Coverage.** Warranty defects shall be remedied during customary business hours at any authorized HISUN dealer located within the United States of America in compliance with the Clean Air Act and applicable regulations of the United States Environmental Protection Agency. Any part or parts replaced under this warranty shall become the property of HISUN.



Hisun Motors Corp., U.S.A. Limited Warranty on Emission Control System

II. Limitations This Emission Control System Warranty shall not cover any of the following:

- A.** Repair or replacement as a result of
 - (1) accident,
 - (2) misuse,
 - (3) repairs improperly performed or replacements improperly installed, unless performed by a HISUN authorized dealer,
 - (4) use of improper replacement parts or accessories not conforming to specifications set forth by HISUN, which adversely affect performance and/or
 - (5) Use in competitive racing or related events.

- B.** Inspections, replacement of parts and other services and adjustments required for required maintenance.



Hisun Motors Corp., U.S.A. Limited Warranty on Emission Control System

C. Any vehicle equipped with an odometer or hour meter on which the odometer mileage or hour meter reading has been changed so that actual mileage cannot be readily determined.

III. Limited Liability

A. The liability of HISUN under this Emission Control System Warranty is limited solely to the remedying of defects in material or workmanship by an authorized HISUN dealer at its place of business during customary business hours. This warranty does not cover inconvenience or loss of use of the vehicle or transportation of the vehicle to or from the HISUN dealer. HISUN shall not be liable for any other expenses, loss or damage, whether direct, incidental, consequential or exemplary arising in connection with the sale or use of or inability to use the vehicle for any purpose. Some states do not allow the exclusion or limitation of any incidental or consequential damages, so the above limitations may not apply to you.



Hisun Motors Corp., U.S.A. Limited Warranty on Emission Control System

- B.** No express emission control system warranty is given by HISUN except as specifically set forth herein. Any emission control system warranty implied by law, including any warranty of merchantability or fitness for a particular purpose, is limited to the express emission control system warranty terms stated in this warranty. The foregoing statements of warranty are exclusive and in lieu of all other remedies. Some states do not allow limitations on how long an implied warranty lasts, so the above limitations may not apply to you.
- C.** No dealer is authorized to modify this Limited Emission Control System Warranty issued by HISUN.
- IV. LEGAL RIGHTS.** This warranty gives you specific legal rights, and you may also have other rights which vary from state to state.
- V.** This warranty is in addition to the limited vehicle warranty.
- VI. ADDITIONAL INFORMATION.** Any replacement part that is equivalent in



Hisun Motors Corp., U.S.A. Limited Warranty on Emission Control System

performance and durability may be used in the performance of any maintenance or repairs by the owner. However, HISUN is not liable for these parts. The owner is responsible for the performance of all required maintenance. Such maintenance may be performed at a service establishment or by any individual. The warranty period begins when the vehicle is placed into service.

If you have any questions regarding your warranty rights and responsibilities, you should contact Hisun Motors Corp., U.S.A., or the U.S. Environmental Protection Agency at 2000 Traverwood Drive, Ann Arbor, MI 48105.

Hisun Motors Corp., U.S.A.

310 E. University Drive
McKinney, TX 75069
Phone: 972-446-0760
Fax: 972-446-0765

Toll-Free: 877-838-6188