

TopTier™ Utility Trailer Loadbar Kit

Model: MPG493 TopTier™ - Assembly Instructions

Take a few moments and read through these instructions to familiarize yourself with the step by step assembly process *before you begin turning wrenches.*

Required Tools:

- (2) 9/16" wrenches
- (1) 7/16" wrench
- (1) 3/8" chuckable nutdriver
- (1) variable speed drill
- (1) tape measure
- (1) hammer

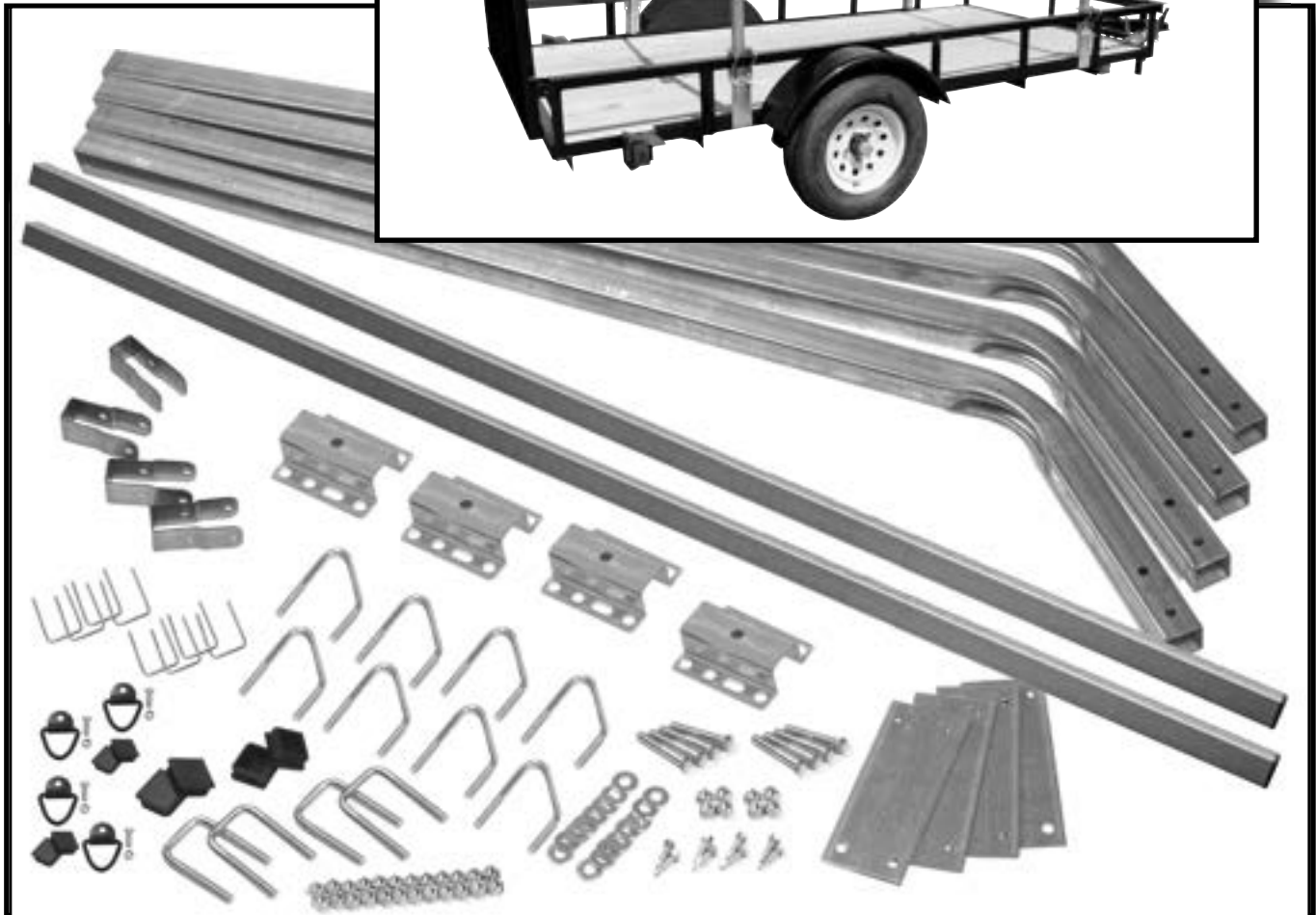

Visit us at maloneautoracks.com for more fine products and accessories.

1. The Malone Utility Trailer Loadbar Kit is designed to fit the most common styles of utility trailer, with raised angle iron side rails turned outward as shown in this picture, as well round and boxed frames. You will need to choose the correct U-bolt during assembly.



2. **IMPORTANT FOR SAFE TRAILERING:** When towing any trailer you always want 10% or more of the total weight of the (trailer + load) to be carried by the hitch ball. A trailer with a properly weighted hitch ball will pull straight behind the tow vehicle. If, as your speed increases, you find the trailer wants to sway back and forth, it's telling you its tongue weight is too light. To eliminate sway, re-arrange your load to shift weight forward onto the hitch ball. Towing a swaying trailer is very dangerous and can pull side to side on the tow vehicle with sufficient force to cause loss of control leading to a jackknife resulting in a crash. So if a sway is ever present, stop and take time to re-arrange more weight forward to eliminate it.

3. **LOAD CAPACITY:** The MPG493 is designed to safely carry up to 250 pounds.

4. We recommend the front loadbar be mounted as far forward as possible and the rear loadbar location vary for spacing.

5. Before starting to mount the kit, check your frame and rails for un-obstructed mounting locations. Look carefully for obstructions that would interfere with mounting the bottom brace plates such as frame cross members, drop gate components, lights, light brackets, fenders, suspension parts, or other obstructions.

6. Assemble all four brackets onto the rails using the proper U-bolts that fit your application.

Partially tighten all the U-bolts to remove most of the slack between the bracket and rail.



7. With the curved top end of each upright turned inward, slide the uprights down into the brackets letting the bottom end rest on the trailer deck as shown.



8. Measure that the uprights are in the same place on both sides of the trailer, then fully tighten all the U-bolts.



9. Assemble the bottom plates as shown using the square U-bolts and nuts, no washers here.

Align the bottom of each plate with the bottom of the frame as shown, and fully tighten the U-bolts.



10. Measure for a final time that all the uprights are equally spaced on both sides of the trailer.

- Check that there are no obstructions behind where you are about to drill.
- Measure that all uprights are vertical.

11. Use the holes in the plates as your drilling guide.

- Use the 3/8" nutdriver.
- Set your variable speed drill to HIGH.
- Apply firm pressure while drilling.
- The screws will thread into the hole they drill. Do not stop the drill until the head seats against the plate. Do not over tighten the screws.

12. Use the hammer to carefully tap the four end plugs into the top ends of the uprights.



13. Slip the load bar brackets over the load bars (as shown) and loosely install the two small bolts / nuts through each bracket trapping the load bars inside the brackets.

14. Install and hand tighten the bolts holding each bracket to the support tube.

15. Center the load bars to the trailer, then tighten all 8 bracket bolts.

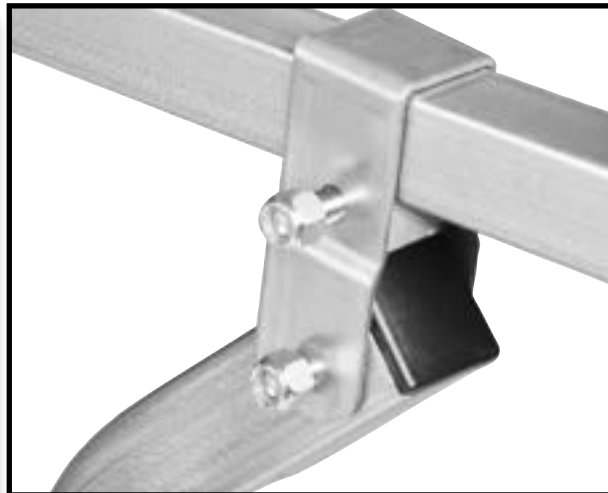
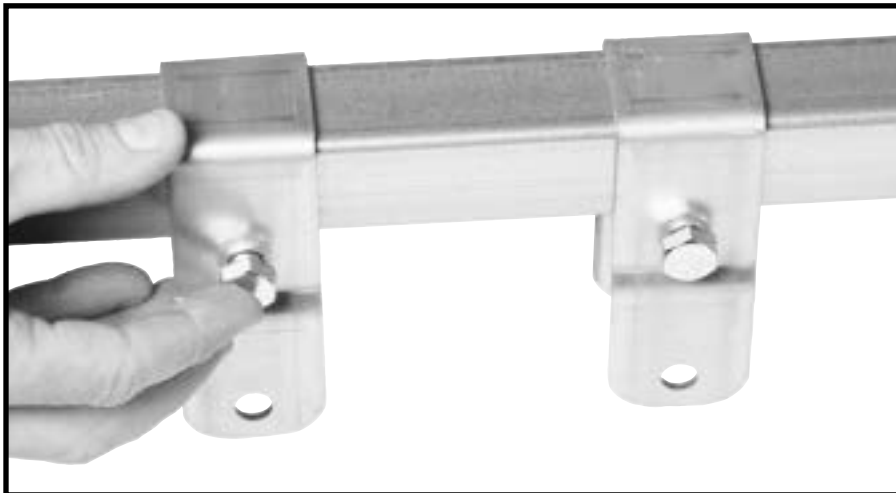

16. Install the D-Rings to the ends of the load bars. Slide a nylon lock nut into the open end of the load bar and align with the hole. Place washer under bolt head and insert it through the D-ring.

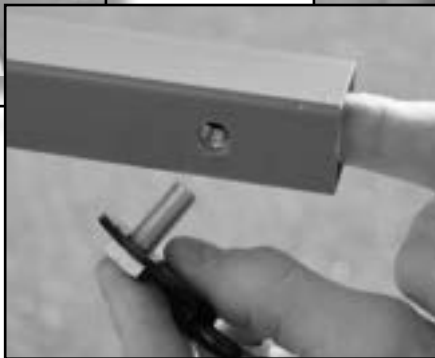
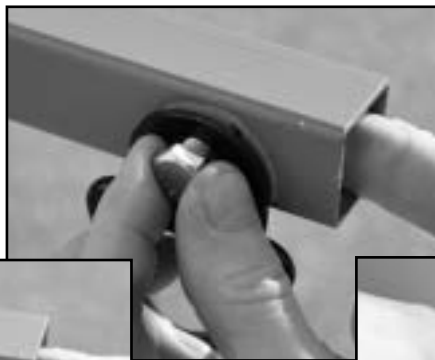
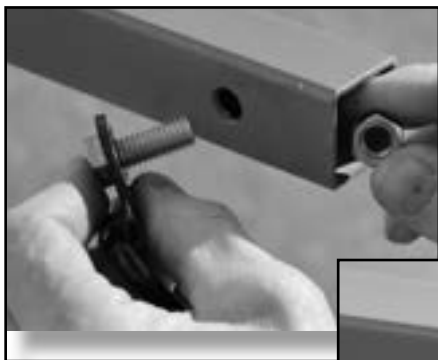

17. Align the bolt to the nut inside the cross bar and hand tighten. To secure fully, use a 9/16" wrench inside the cross bar to capture the nut inside. A 9/16" socket is used on the bolt head. Complete the cross bars with the new end caps. Repeat for remaining D-rings and end caps.

18. With the load bars centered, gently tighten all loadbar bracket bolts. Do not over tighten. Over-tightening will crush the tube or brackets.

19. Go back over and re-check that all nuts and bolts are securely tightened



*Visit us at **maloneautoracks.com**
for more fine products and accessories.*

MALONE AUTO RACKS 81 County Rd. Ste 1, Westbrook, ME 04092
P: 207.774.9100 F: 207.615.0551
E: support@maloneautoracks.com W: www.maloneautoracks.com