

GRILL CART WITH STORAGE CABINET

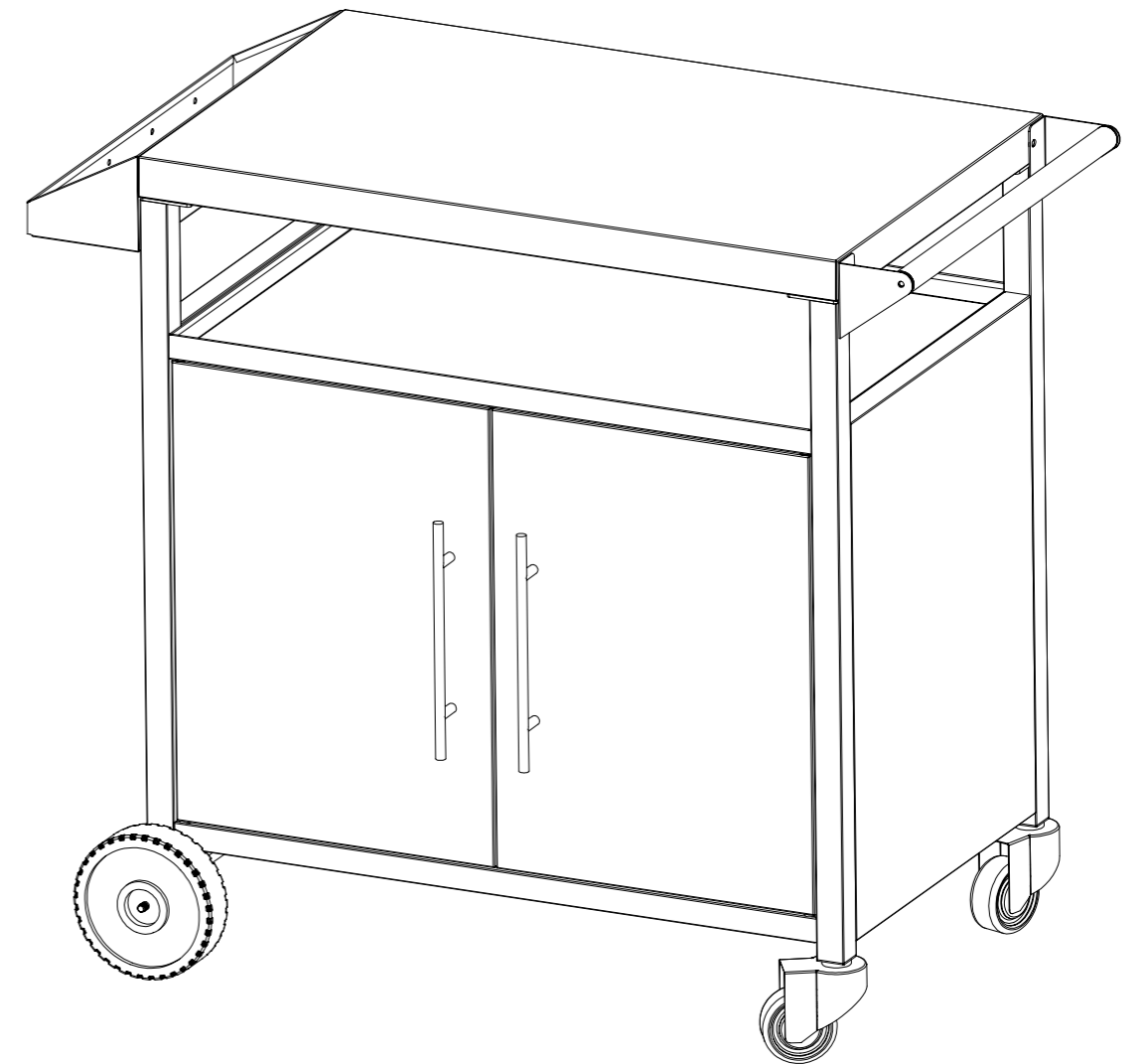

ASSEMBLY INSTRUCTIONS INSTRUCCIONES DE ENSAMBLAJE

MODEL NUMBER: GC-02
NÚMERO DE MODELO: GC-02



PLEASE READ THE PRECAUTIONS IN THE INSTALLATION INSTRUCTIONS CAREFULLY TO PREVENT TROUBLES CAUSED BY INCORRECT INSTALLATION.

LEA ATENTAMENTE LAS PRECAUCIONES DE LAS INSTRUCCIONES DE INSTALACIÓN PARA EVITAR PROBLEMAS CAUSADOS POR UNA INSTALACIÓN INCORRECTA.

CONTENTS / CONTENIDO:

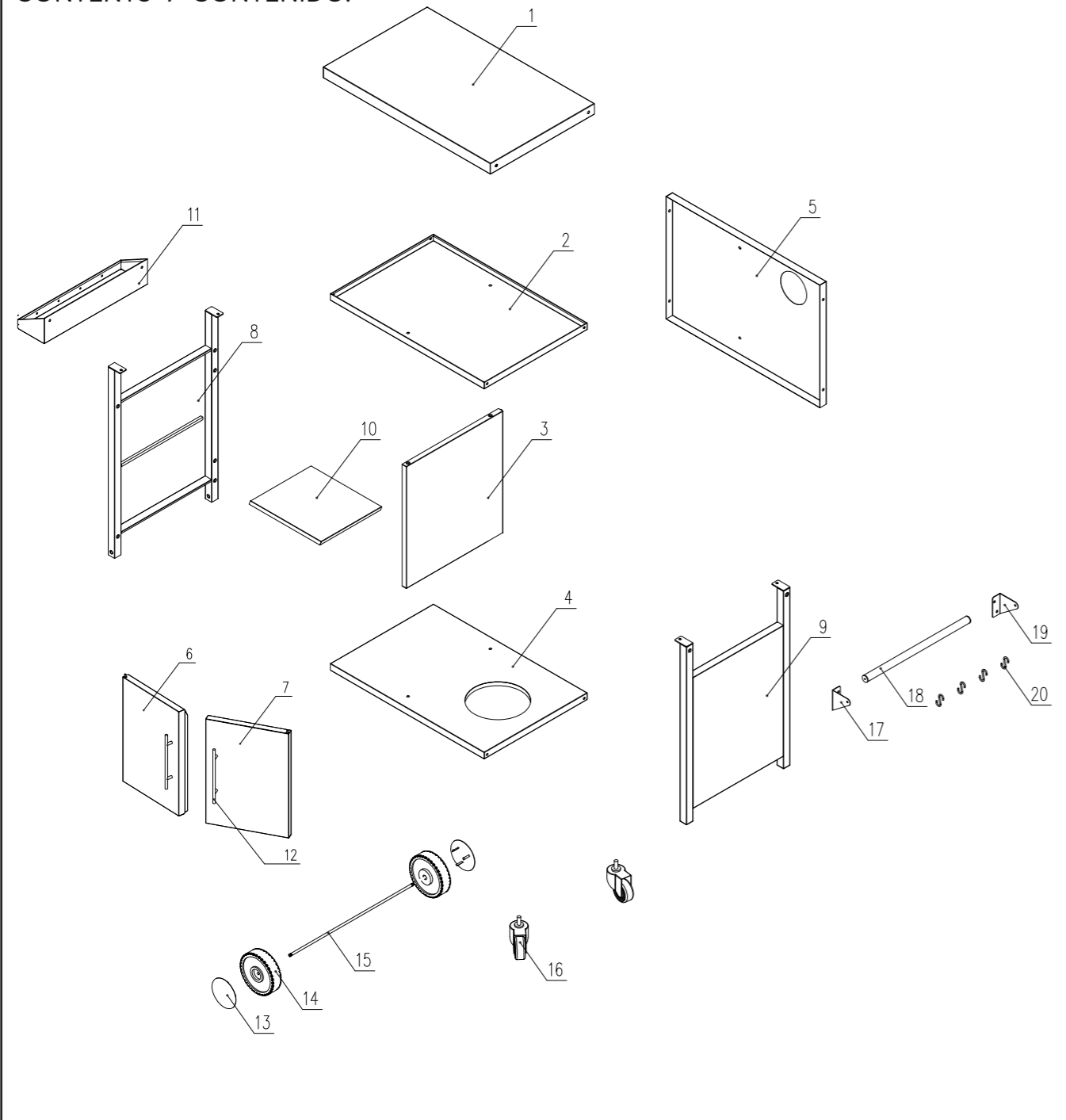

PARTS DIAGRAM

Item	Description	Qty.
1	Table top	1
2	Second shelf	1
3	Vertical cabinet divider	1
4	Base shelf	1
5	Back board	1
6	Cabinet door-left	1
7	Cabinet door-right	1
8	Left side panel	1
9	Right side panel	1
10	Lateral cabinet divider	1
11	Seasoning box	1
12	Door pull	2
13	Wheel cover	2
14	PE wheel	2
15	Axle	1
16	Caster	2
17	Left handle bracket	1
18	Handle	1
19	Right handle bracket	1
20	S hook	4

⚠ Two person assembly recommended
 ⚠ Se recomienda el montaje por dos personas

Tools required:
 Herramientas necesarias:



Part#	Diagram	Description	Qty.
A		M6x12 Inner Hex Screw	30
B		M8 Lock Nut	2
C		M4x8 Screw	4

1. Tools required: 4 M6*12 screws

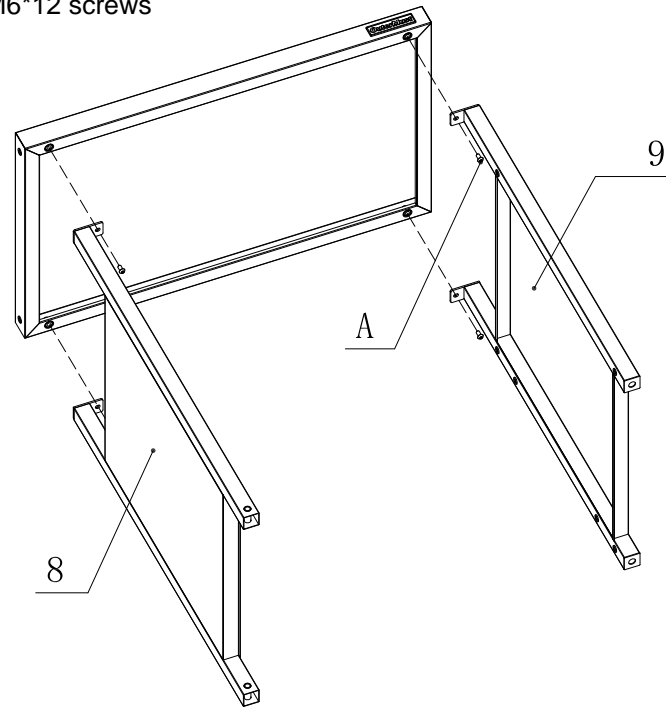

Attach left side panel (8) and right side panel (9) to table top (1) using 4 M6*12 screws (A).
Fije el panel lateral izquierdo (8) y el panel lateral derecho (9) al tablero de la mesa (1) con 4 tornillos M6*12 (A).

2. Tools required: 4 M6*12 screws

Alert: The second shelf is dish flat form as shown in the diagram, with two mounting holes on the bottom towards doors.

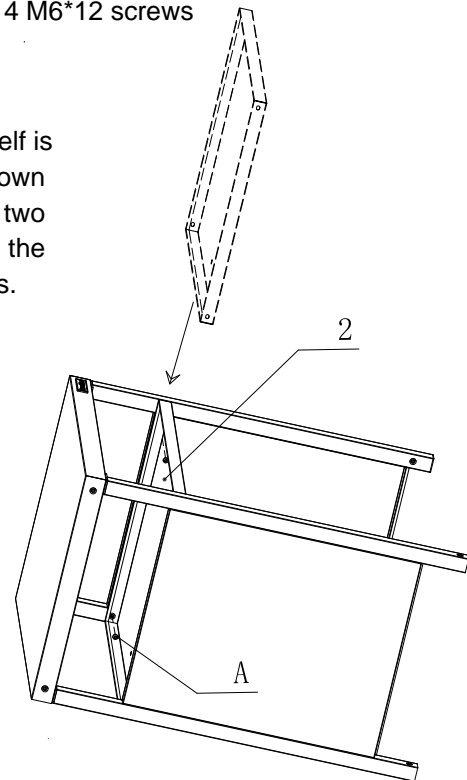

Screw the above assembly and second shelf (2) with 4 M6x12 screws (A).
Atornille el conjunto anterior y el segundo estante (2) con 4 tornillos M6x12 (A).

Note: For subsequent installation, do not fully tighten the screws.
Nota: Para la instalación posterior, no apriete completamente los tornillos.

Alerta: El segundo estante es plato forma plana como se muestra en el diagrama, con dos agujeros de montaje en la parte inferior hacia las puertas.

3. Tools required: 4 M6*12 screws

Note: When installing the back board, the round hole preformed for LP cylinder pipe (not included) towards the right side panel (9).

Nota: Al instalar el tablero trasero, el agujero redondo preformado para el tubo del cilindro LP (no incluido) hacia el panel lateral derecho (9).

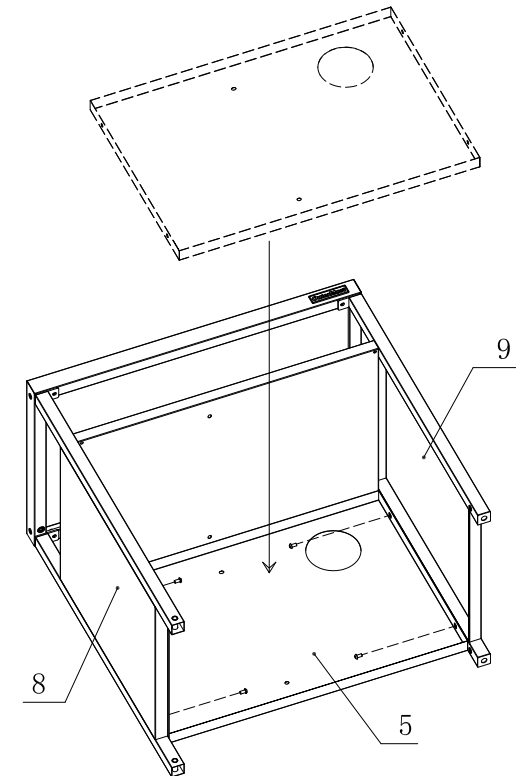

Fasten the back board (5) with 4 M6x12 screws (A).
Fije la placa posterior (5) con 4 tornillos M6x12 (A).

4. Tools required: 4 M6*12 screws

Note: When installing the base shelf, cylinder mounting bracket should be on the side of the round hole in the back board.

Nota: Al instalar el estante base, el soporte de montaje cilíndrico debe estar en el lado del orificio redondo del tablero trasero.

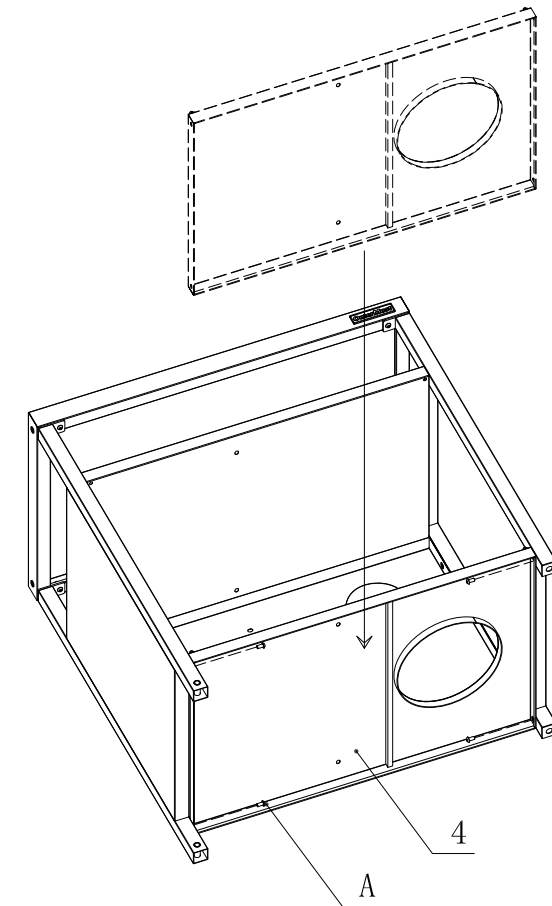

Fasten the base shelf (4) with 4 M6x12 screws.
Fije el estante base (4) con 4 tornillos M6x12.

5. Tools required: 6 M6*12 screws

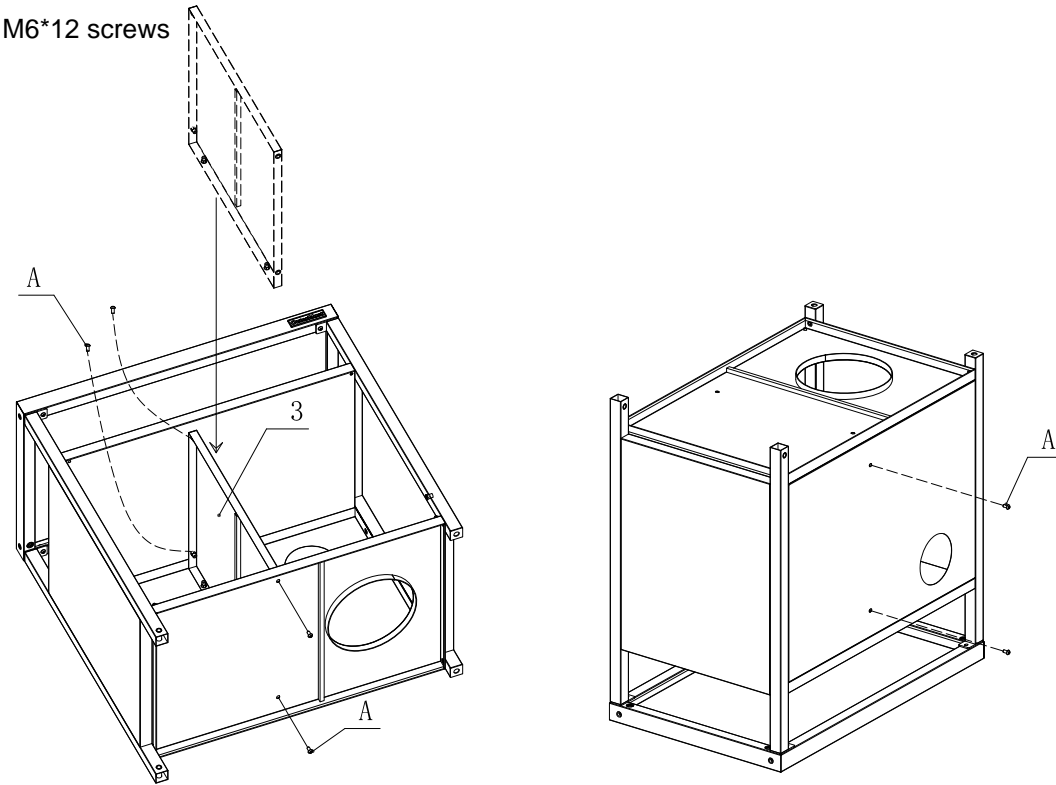

Fasten the vertical cabinet divider (3) with 6 M6*12 screws.
Fije el separador vertical del armario (3) con 6 tornillos M6*12.

6.

Note: Before you install these casters, please press the brake first to facilitate subsequent installation
Nota: Antes de instalar estas ruedas, presione primero el freno para facilitar la instalación posterior

Install the 2 casters (16) in the appropriate position.
Instale las ruedas de 2 (16) en la posición adecuada.

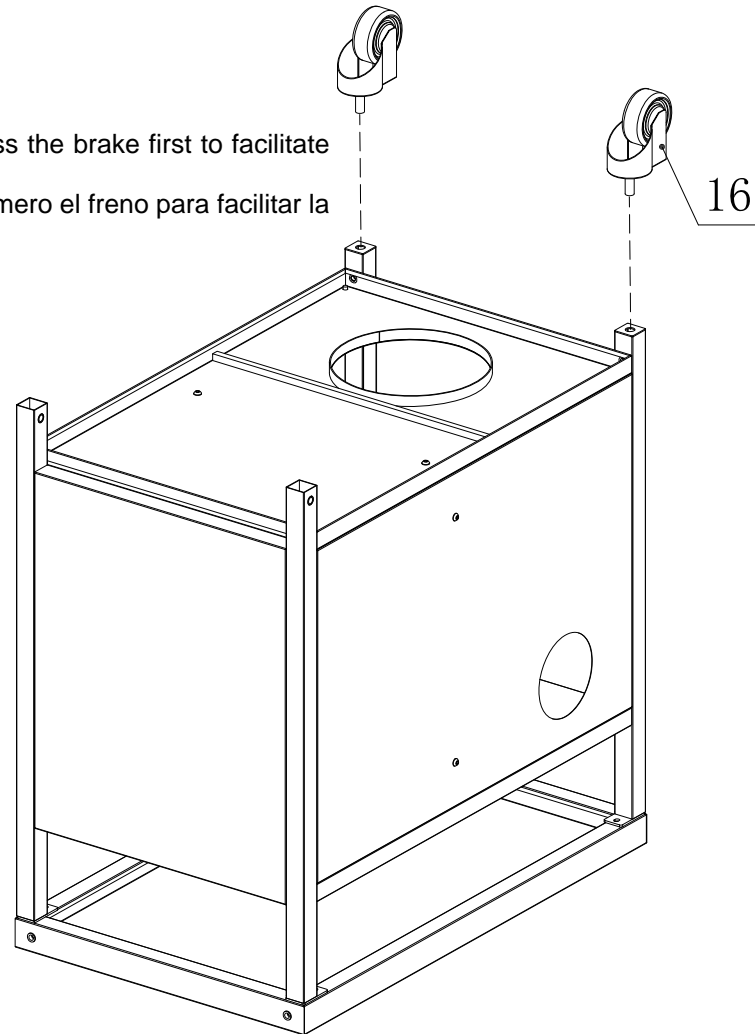

7. Tools required: 2 M8 lock nuts

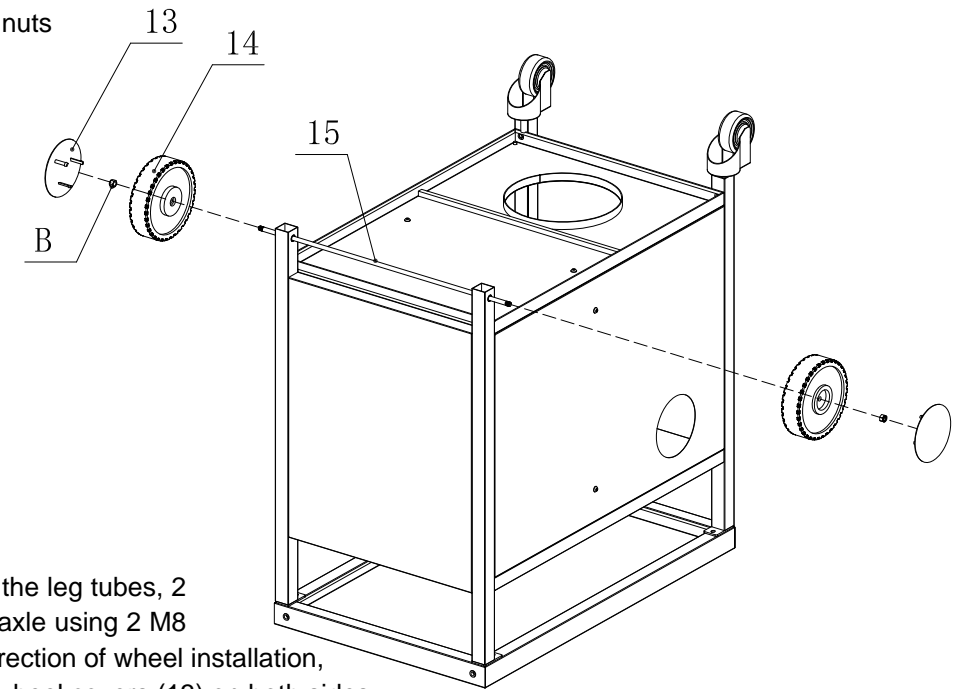

After inserting the axle (15) into the leg tubes, 2 PE wheels (14) are set into the axle using 2 M8 lock nuts (pay attention to the direction of wheel installation, raised towards the inside). Add wheel covers (13) on both sides.

Después de insertar el eje (15) en los tubos de las patas, se fijan 2 ruedas de PE (14) en el eje utilizando 2 contratuerzas M8 (prestar atención al sentido de instalación de las ruedas, levantadas hacia el interior).
Añada las cubiertas de las ruedas (13) a ambos lados.

8.

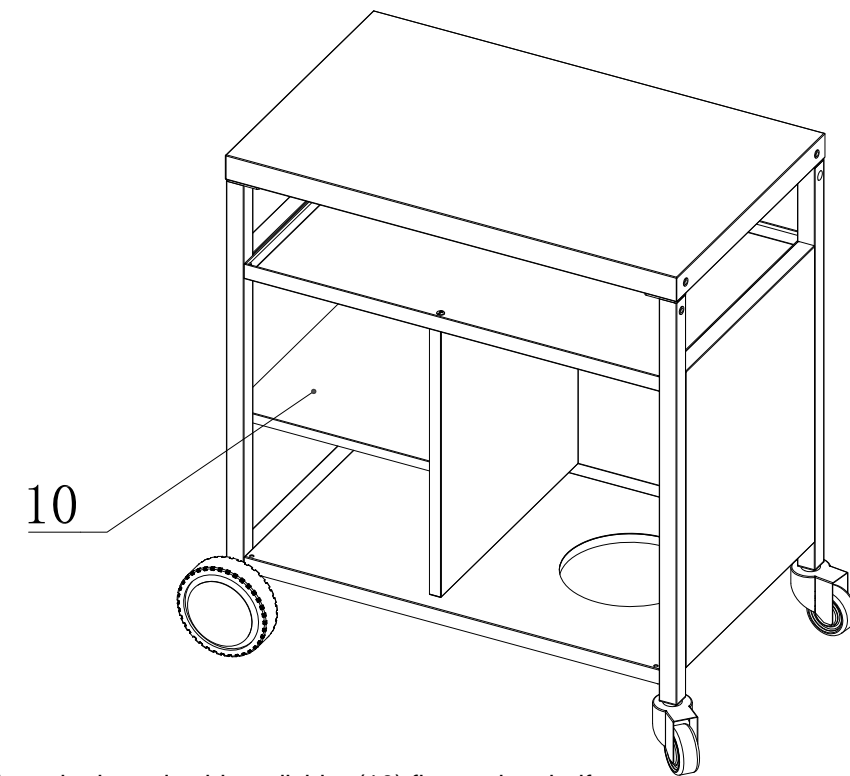

Place the lateral cabinet divider (10) flat on the shelf.
Coloque el separador lateral de armarios (10) plano sobre la estantería.

9. Tools required: 4 M6*12 screws

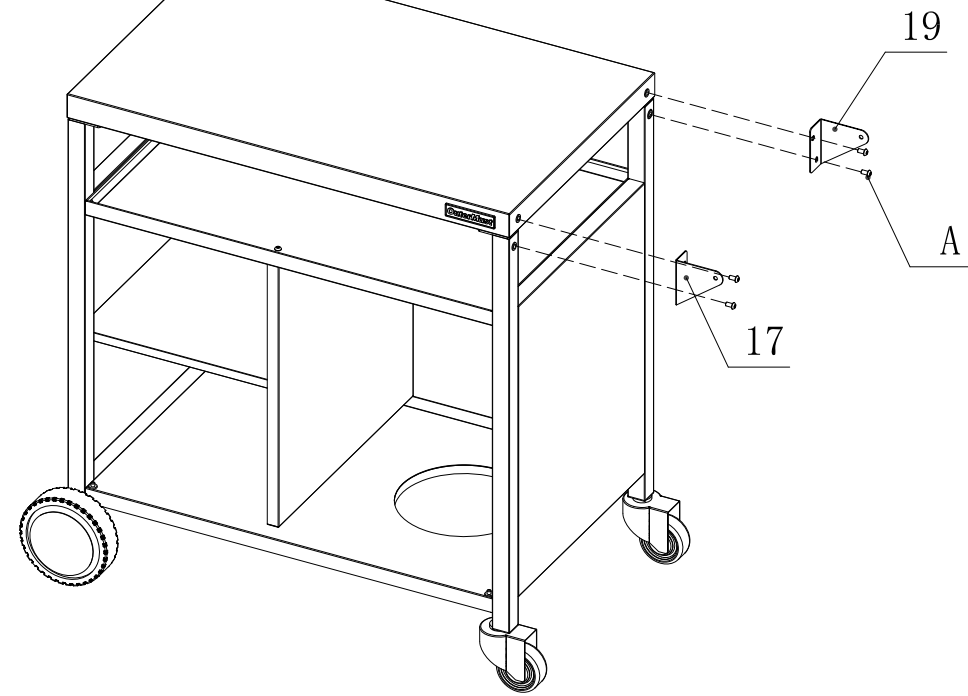

Fasten left handle bracket (17) and right handle bracket (19) to the mounted body with 4 screws M6x12 (A).
Fije los soportes izquierdo (17) y derecho (19) del asa al cuerpo montado con 4 tornillos M6x12 (A).

10. Tools required: 2 M6*12 screws

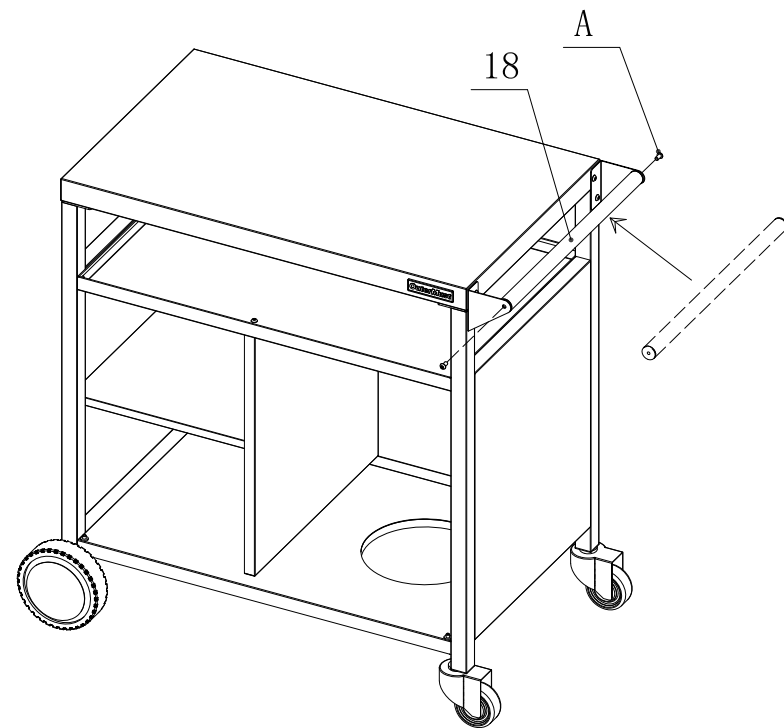

Fasten handle (18) with 2 M6x12 (A) screws to the handle connecting parts just installed.
Fije la empuñadura (18) con 2 tornillos M6x12 (A) a las piezas de unión de la empuñadura que se acaban de instalar.

11. Tools required: 2 M6*12 screws

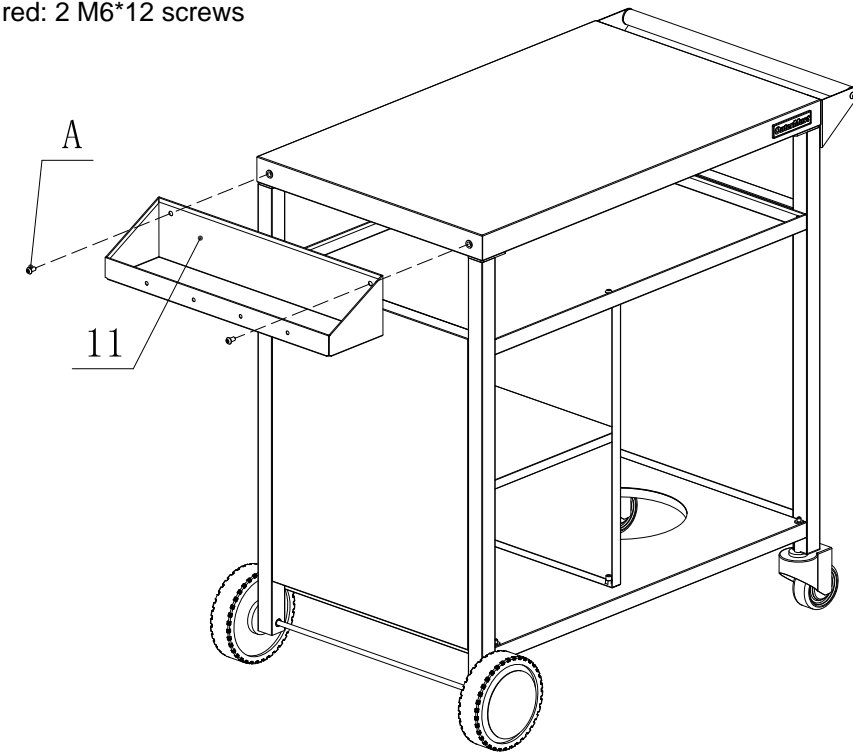

Fasten the seasoning box (11) with 2 M6x12 screws (A).
Fije la caja de condimentos (11) con 2 tornillos M6x12 (A).

12. Tools required: 4 M4*8 screws

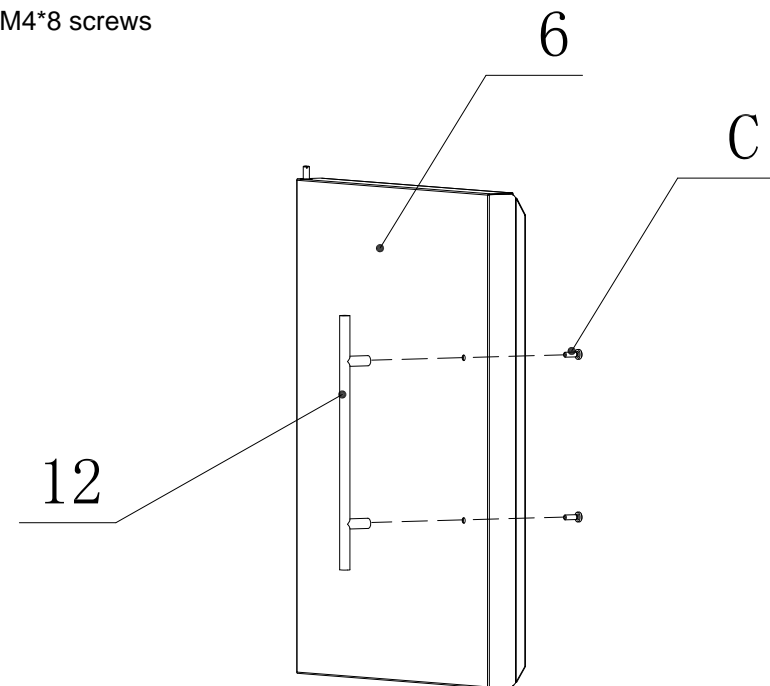

Fix the left cabinet door (6) and door pull (12) with 2 M4x8 screws. Right cabinet door (7) mounted in the same way.

Fije la puerta izquierda del armario (6) y el tirador de la puerta (12) con 2 tornillos M4x8. La puerta derecha del armario (7) se monta de la misma manera.

13.

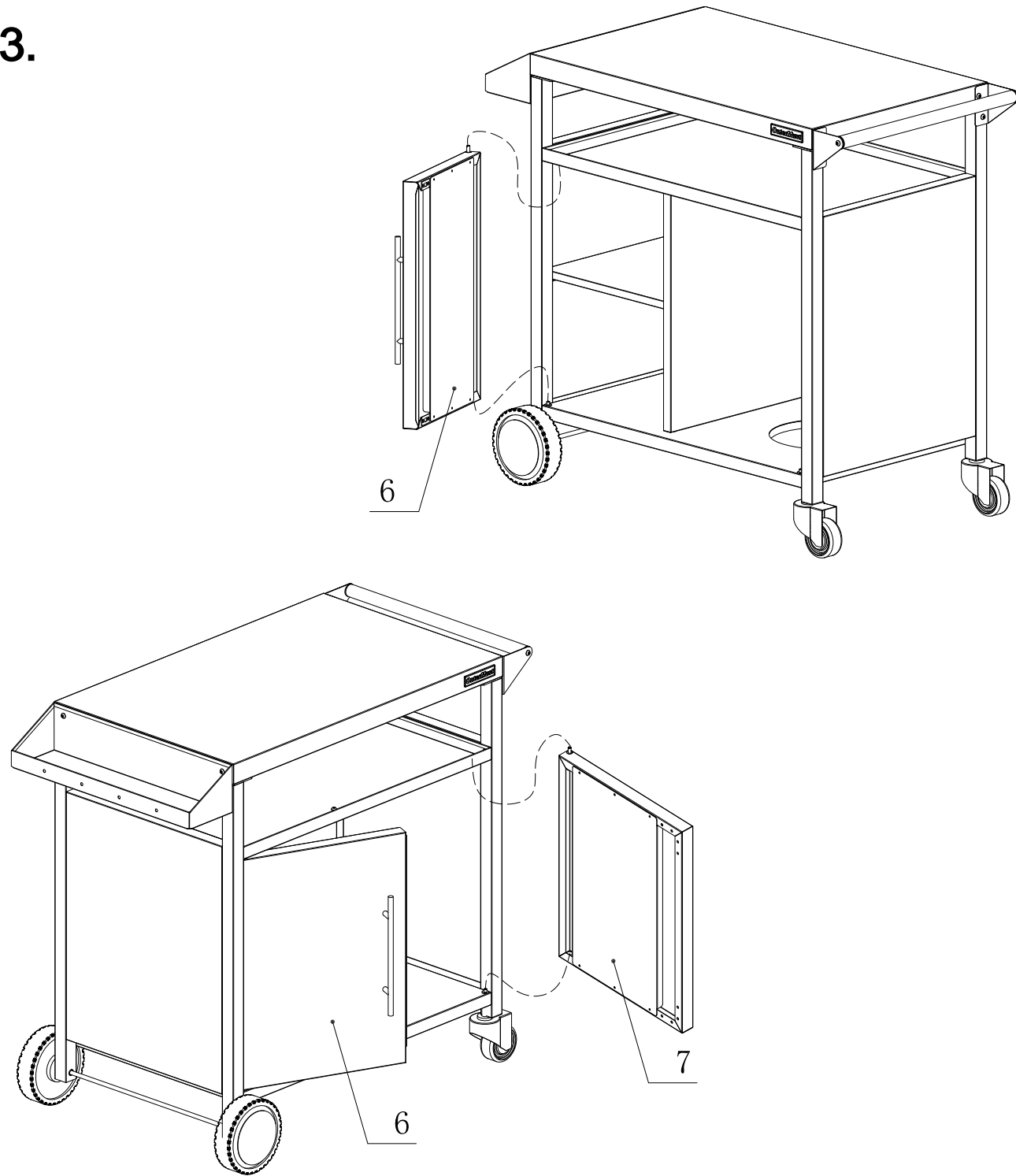

Insert the small hole at the bottom of the cabinet doors (6&7) into the pin and press the upper spring so that it snaps into the upper hole.

Introduzca el pequeño orificio de la parte inferior de las puertas del armario (6 y 7) en el pasador y presione el muelle superior para que encaje en el orificio superior.

Note: Tighten all screws to make this grill cart more stable.

Nota: Apriete todos los tornillos para que este carro grill sea más estable.