











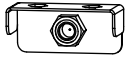

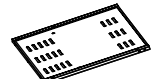
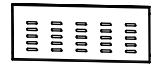



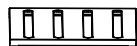

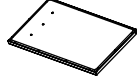
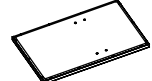





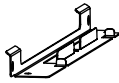
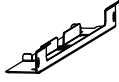
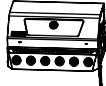
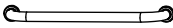







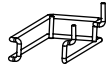

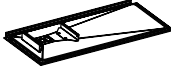
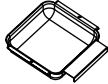
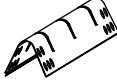





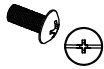

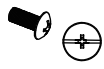

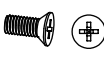

No.	#	QTY / CANT. / QTÉ	Description / Descripción / Description	Image / Imagen / Image
1	05-WXL-20	4	Caster Rueda Roulette	
2	AJDB05H5B	1	Bottom shelf Estante inferior Etagere inferieure	
3	AJQPGDZ01	1	Screw bushing Buje del perno de fijación de la bombona Douille de vis	
4	07-QPG-05-SI	1	LP cylinder screw Perno de fijación de la bombona Vis de bouteille de gaz	
5	AJCBL02	1	Left panel Panel izquierdo Panneau gauche	
6	AJCBR04	1	Right panel Panel derecho Panneau droit	
7	AJHB025B	1	Rear panel Panel trasero Panneau arrière	
8	AJSJJQPL02	1	Triangle support plate (L) Placa de soporte triangular (I) Plaque de support triangulaire (G)	
9	AJSJJQPR02	1	Triangle support plate (R) Placa de soporte triangular (D) Plaque de support triangulaire (D)	
10	GD17JCBZC01	2	Shelf support Soporte del estante Support d'étagère	
11	AJZCB01	1	Middle shelf Estante central Etagère du milieu	
12	AJQPGB01-DS1	1	Thermal baffle Deflector térmico Panneau isolant	
13	AJQHL02H5B	1	Cart front beam Barra frontal del carro Poutre avant du chariot	
14	AJML035B	1	Cabinet door (L) Puerta del armario (I) Porte d'armoire (G)	
15	AJMR035B	1	Cabinet door (R) Puerta del armario (D) Porte d'armoire (D)	
16	EJGG01	1	Hook Gancho Crochet	
17	AJCWL01H	1	Basket Cesta Panier	

No.	#	QTY / CANT. / QTÉ	Description / Descripción / Description	Image / Imagen / Image
18	AJMBSL015B	1	Door handle (L) Tirador de la puerta (I) Poignée de la porte (G)	
19	AJMBSR015B	1	Door handle (R) Tirador de la puerta (D) Poignée de la porte (D)	
20	EJMGDPL01	1	Beam connector (L) Unión de la barra (I) Connecteur de faisceau (G)	
21	EJMGDPR01	1	Beam connector (R) Unión de la barra (D) Connecteur de faisceau (D)	
22	ALYPZJL02	1	Grease tray bracket (L) Fijación de Bandeja de recojida de grasa (I) Support du Lèchefrite (G)	
23	ALYPZJR02	1	Grease tray bracket (R) Fijación de Bandeja de recojida de grasa (D) Support du Lèchefrite (D)	
24		1	Main body Cuerpo principal Corps principal	
25	04-GBS-2-56 -600-PT1	1	Lid handle Manija de la tapa Poignée du couvercle	
26	AB31BL02H	1	Side burner shelf Base del quemador lateral Étagère du bruleur d'appoint	
27	06-XNZ-5-01-BK	1	Knob base Base de mando de regulación de llama Base du bouton	
28	06-XNL-5-17ABK -PDD1-PBK-RGC	1	Knob Mando de regulación de llama Bouton	
29	01-LTL-4-19-230 -F-SS4	1	Side burner Quemador lateral Bruleur d'appoint	
30	AT31ZDCT02H	1	Side shelf Bandeja lateral Étagère latérale	
31	06-CTL-06	1	Magnetic tool holder Soporte magnético para herramientas Porte-outils magnétique	
32	AT31GDZJL01 -SS4	1	Side shelf support plate (L) Placa de sujeción de la bandeja lateral (I) Plaque de support de la étagère latérale (G)	
33	AT31GDZJR01 -SS4	1	Side shelf support plate (R) Placa de sujeción de la bandeja lateral (D) Plaque de support de la étagère latérale (D)	
34	06-XZL-3-25 -DD1	1	Paper towel holder Portarrollos de papel Porte-serviettes en papier	

No.	#	QTY / CANT. / QTÉ	Description / Descripción / Description	Image / Imagen / Image
35	07-GLL-10-DD1	1	Wire basket Cesta de alambre Panier en maille métallique	
36	ALJYP015B-DS2	1	Grease tray Bandeja de recogida de grasa Lèche-frite	
37	TY-YB01-LS4	1	Grease cup Depósito de recogida de grasa Bac à graisse	
38	ALFHB01-SS4	4	Flame tamer Regulador de llama Atténuateur de flamme	
39	ALFHB02-SS4	1	Flame tamer (big) Regulador de llama (grande) Gros atténuateur de flamme	
40	03-ZTW-A-01 -TC4	1	Cooking grate (big) Rejilla para asar (grande) Gros grille de cuisson	
41	03-ZTW-A-02 -TC4	1	Cooking grate Rejilla para asar Grille de cuisson	
42	03-ZTW-A-03 -TC4	1	Sear grate Rejilla para marcar la carne Grille de marquage de la viande	
43	03-GJL-08-TC3	1	Side burner grate Rejilla del quemador lateral Grille du bruleur d'appoint	
44	03-BWW-A-01 -5B-DD1	1	Warming rack Rejilla para calentar Grille de réchauffement	

No.	#	Image / Imagen / Image	No.	#	Image / Imagen / Image
A	M6x12	 ×41	H	M4x10	 ×10
B	M5x10	 ×26	I	Washer Arandela Rondelle	 ×2
C	M4x8	 ×6	J	M6x20	 ×2
D	M5x10	 ×12	K	M6x20	 ×3
E	Magnet Imán Aimant	 ×1	L	M4	 ×4
F	Spring washer Arandela elástica Rondelle élastique	 ×2	M	M4x25	 ×4
G	Stud with nut Espárrago con tuerca integrada Goujon avec écrou	 ×4			

**TOOLS REQUIRED / HERRAMIENTAS REQUERIDAS / OUTILS REQUIS**

Phillips screwdriver Destornillador phillips Tournevis phillips	Wrench Llave Clé		
---	------------------------	--	---

Before beginning assembly, make sure all parts are present. If any parts are missing or damaged, do not attempt to assemble the products. Contact customer service for replacement parts via telephone or email.

- Tools needed (not included): Phillips screwdriver and wrench
- Approximate assembly time: 60-80 minutes
- Note: 1. The right and left sides of the grill are designed as if you are facing the front of the grill.  
2. Model shown for illustration purpose only, specific please in kind prevail.

Antes de comenzar el montaje, asegúrese de que todas las piezas estén presentes. Si falta alguna pieza o está dañada, no intente ensamblar los productos. Póngase en contacto con el servicio de atención al cliente para obtener piezas de repuesto por teléfono o correo electrónico.

- Herramienta necesaria (no incluido): Destornillador phillips y llave
- Tiempo aproximado de ensamblaje: 60-80 minutos
- Nota: 1. Los lados derecho e izquierdo de la parrilla están diseñados como si estuvieras frente a la parte delantera de la parrilla.  
2. El modelo que se muestra es sólo para fines ilustrativos, prevalecen los específicos en especie.

Avant de commencer l'assemblage, assurez-vous que toutes les pièces sont présentes. Si des pièces sont manquantes ou endommagées, n'essayez pas d'assembler les produits. Contactez le service de clientèle pour les pièces de rechange par téléphone ou par e-mail.

- Outils nécessaires (non inclus): Tournevis phillips et clé
- Temps nécessaire pour l'assemblage: 60-80 minutes
- Remarque: 1. les côtés droit et gauche du gril sont conçus comme si vous faisiez face à l'avant du gril.  
2. le modèle est présenté à des fins d'illustration uniquement, spécifiques en nature prévalent.

1 A  x16

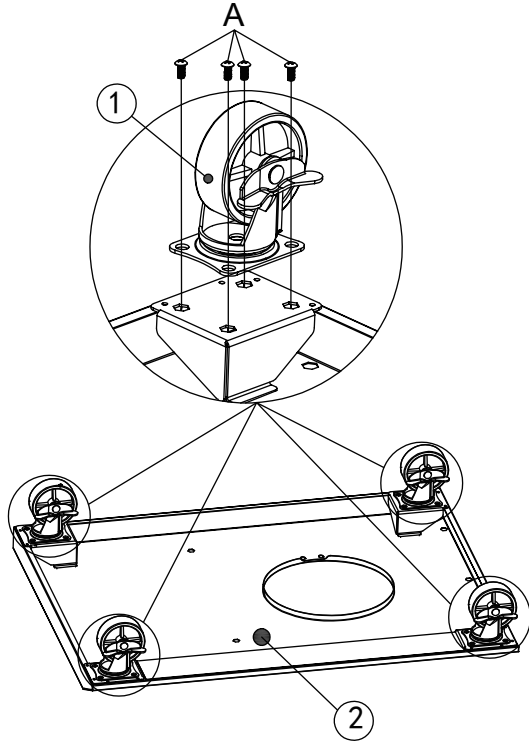

2 A  x2

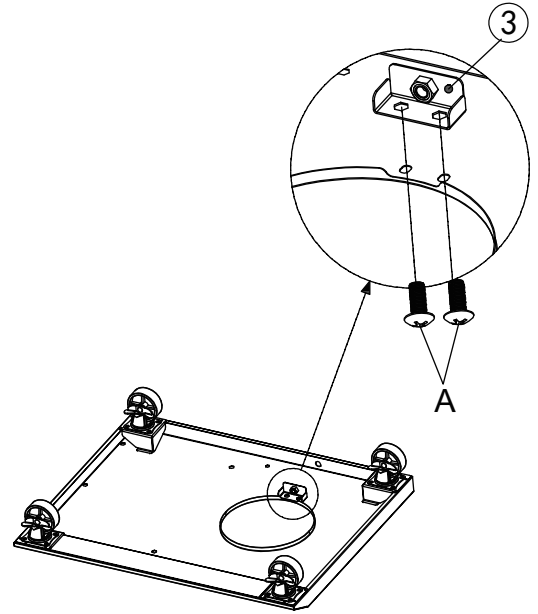

3

- Use the pre-installed screws from the LP cylinder screw.
- Utilice los tornillos preinstalados del tornillo del cilindro GLP.
- Utilisez les vis pré-installées de la bonbonne de gaz LP.

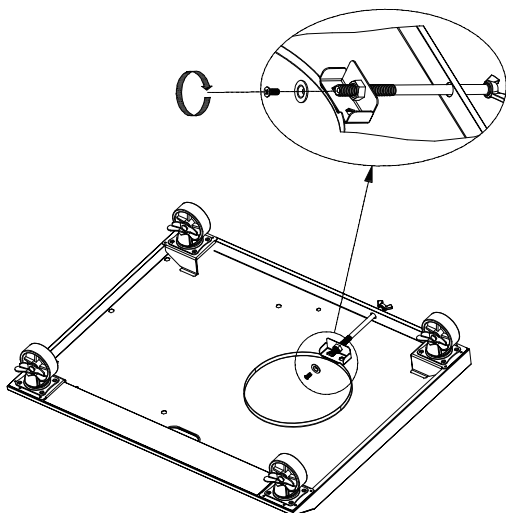
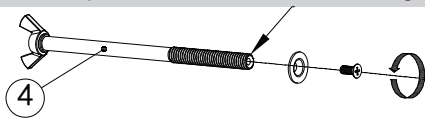

4

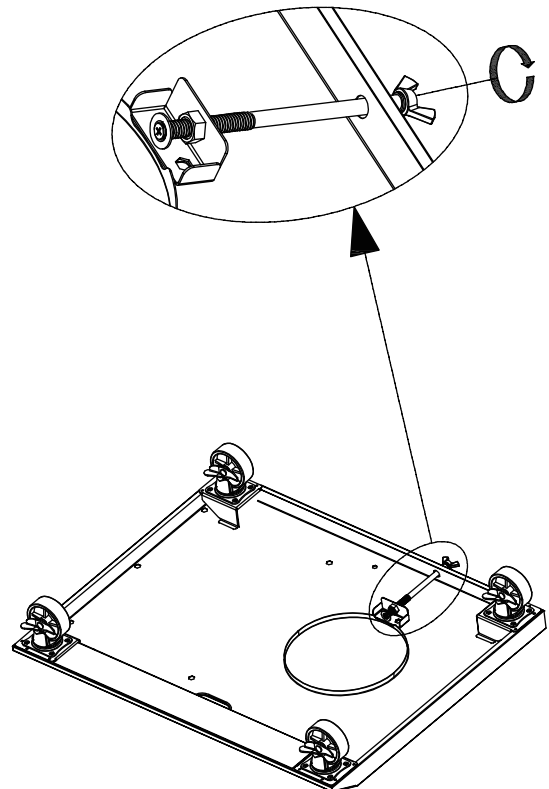

**5** A  x6

- Do not fully tighten the screws A until step 6 and 7.
- No apriete completamente los tornillos A hasta el paso 6 y 7.
- Ne serrez pas à fond les vis A avant l'étape 6 et 7.

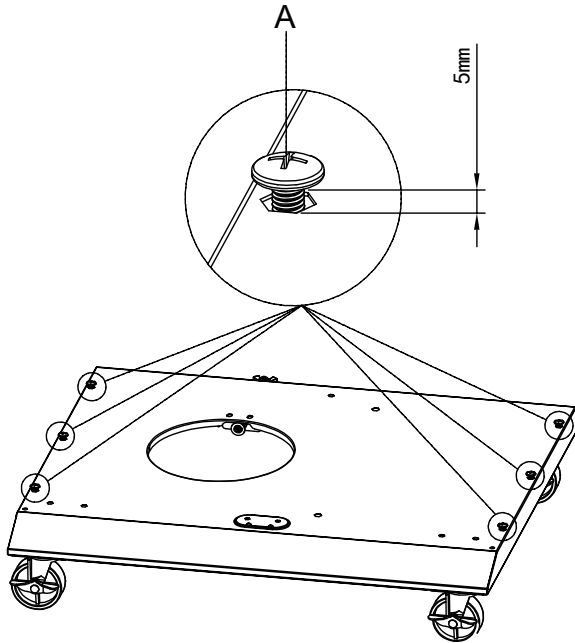

**6**

- Snap & tighten
- Encajar y apretar
- Endenche et serre

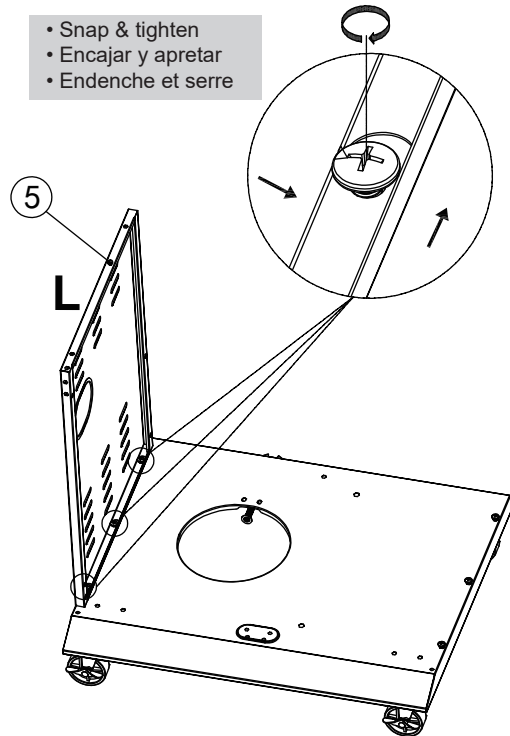

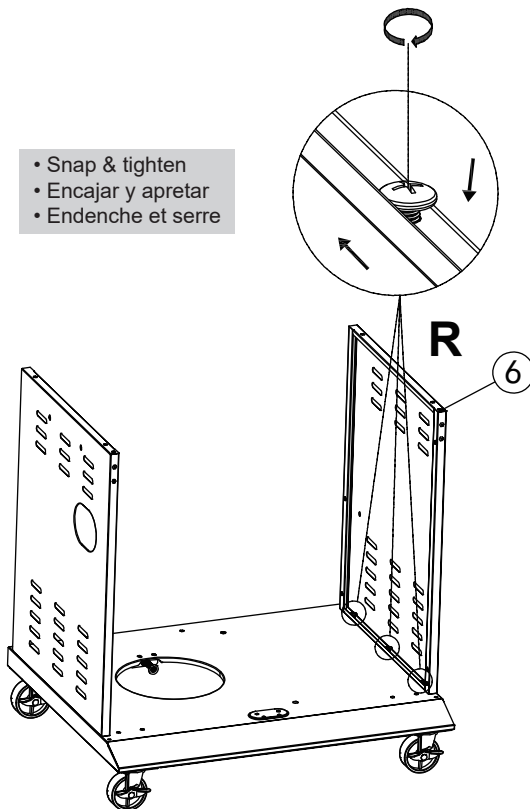

**7**

- Snap & tighten
- Encajar y apretar
- Endenche et serre

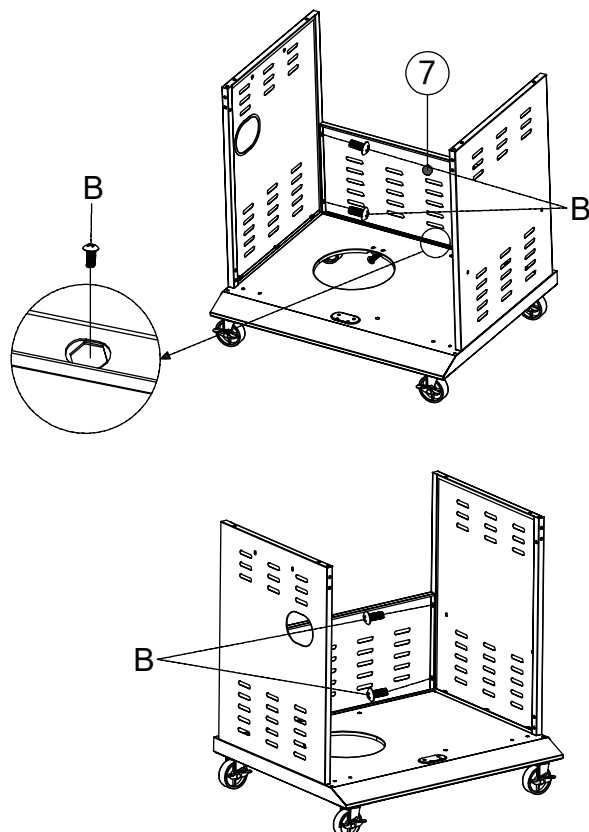

**8** B  x5



**9** B  x4

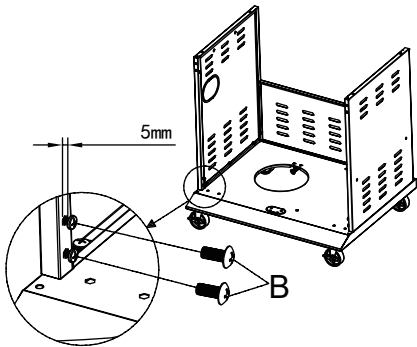



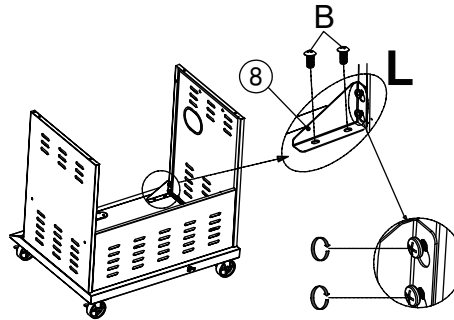

- Do not fully tighten the screws B until step 10.
- No apriete completamente los tornillos B hasta el paso 10.
- Ne serrez pas à fond les vis B avant l'étape 10.

**10** B  x4

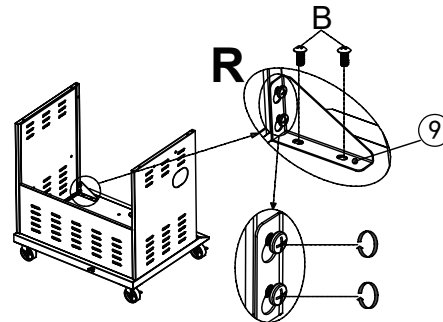
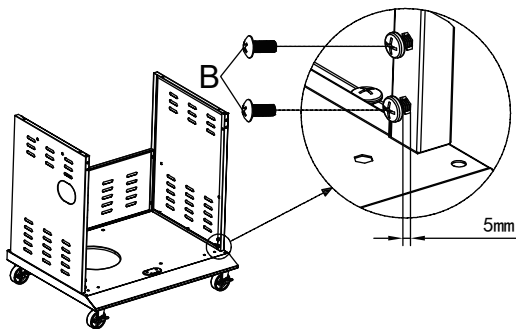

- Snap & tighten
- Encajar y apretar
- Endenche et serre



**11** C  x2    B  x2  
E  x1

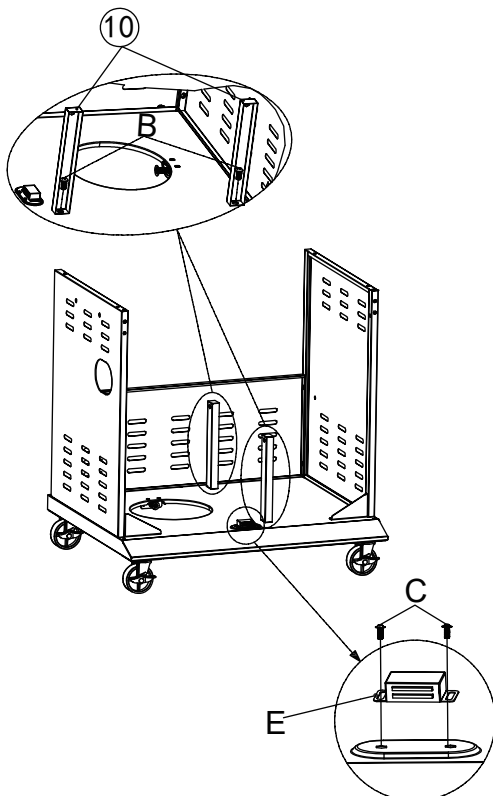

**12** A  x4

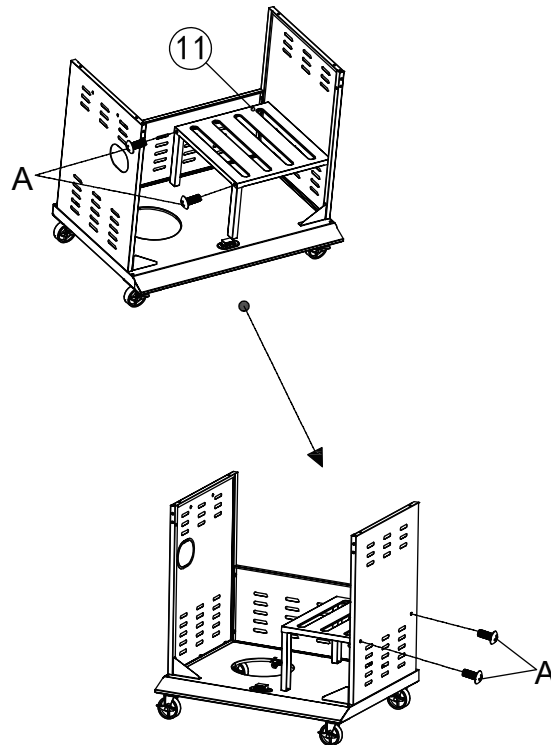

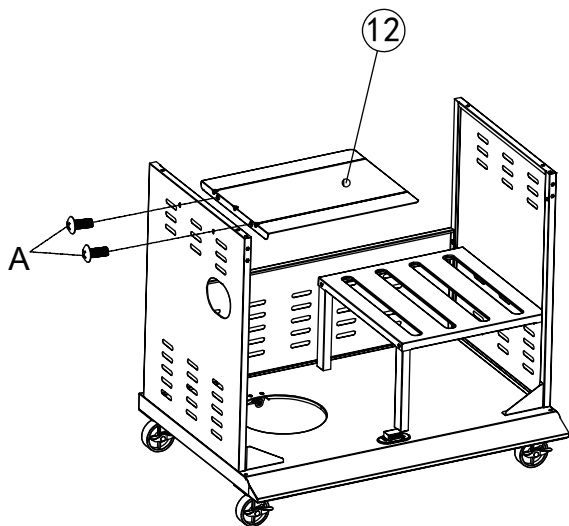

**13** A  x2

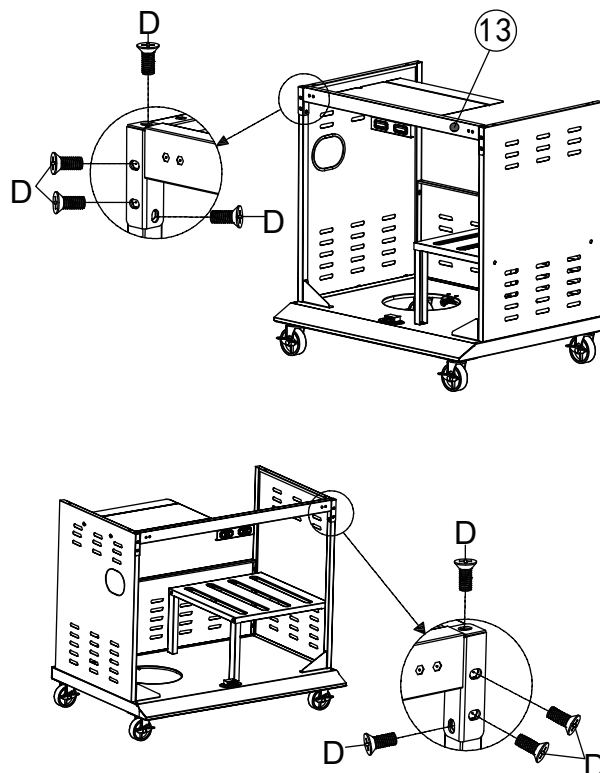

**14** D  x8



**15** G  x2 H  x3  
B  x3

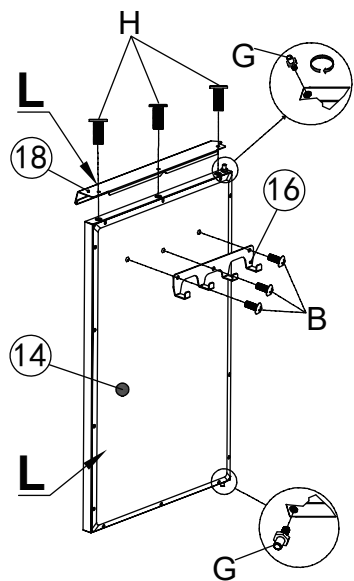

**16** G  x2 H  x3  
B  x4

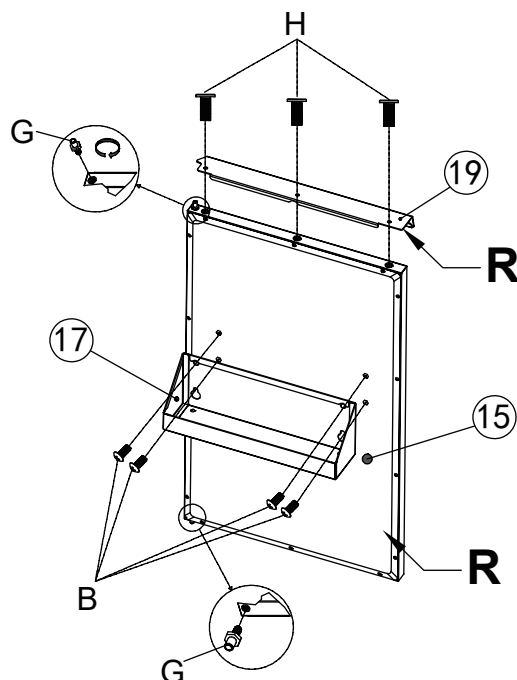

17 H  x4

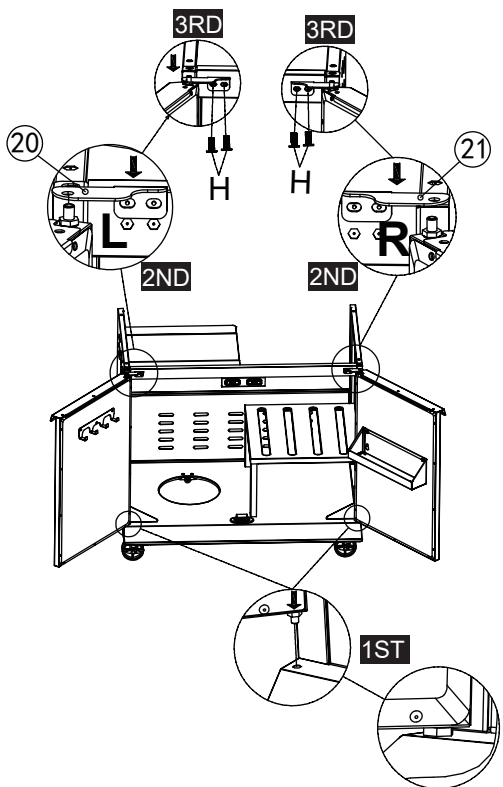

18 D  x4

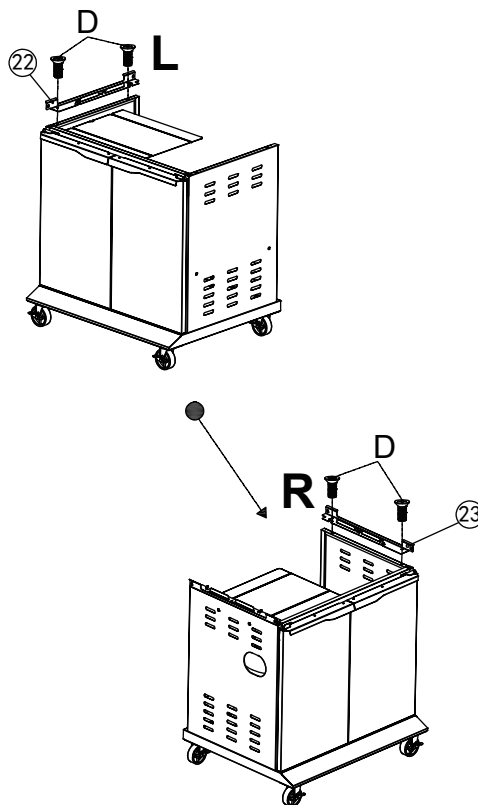

19

- Side burner valve
- Válvula del quemador lateral
- Valve de brûleur latéral

- Regulator
- Regulador
- Régulateur

- Ignition module
- Módulo de ignición
- Module d'allumage

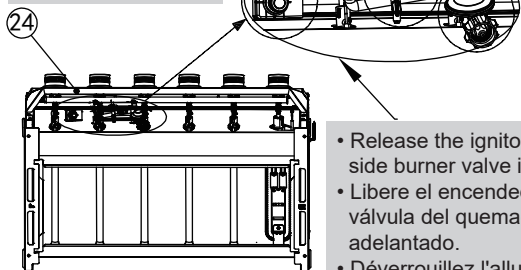

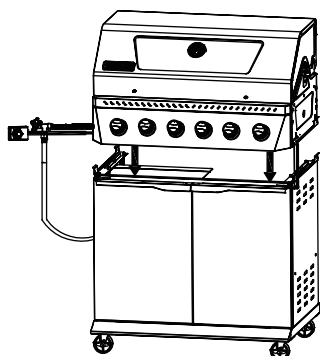

- Release the ignitor, regulator and side burner valve in advance.
- Libere el encendedor, el regulador y válvula del quemador lateral por adelantado.
- Déverrouillez l'allumeur, le régulateur et valve de brûleur latéral à l'avance.



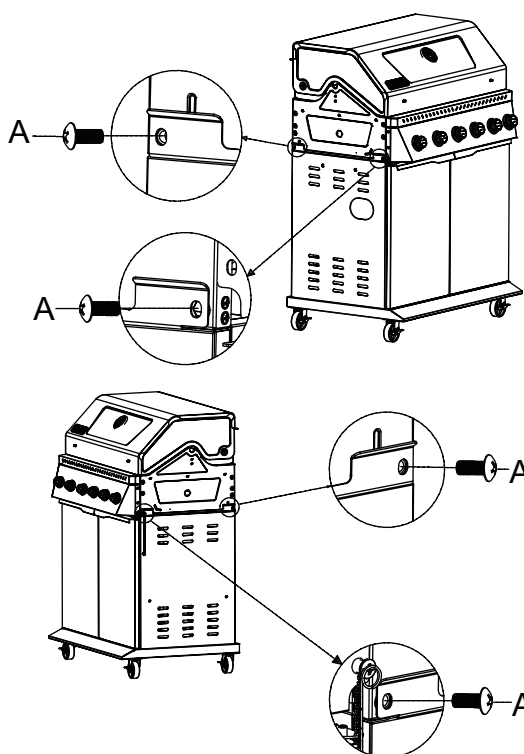

20 A  x4

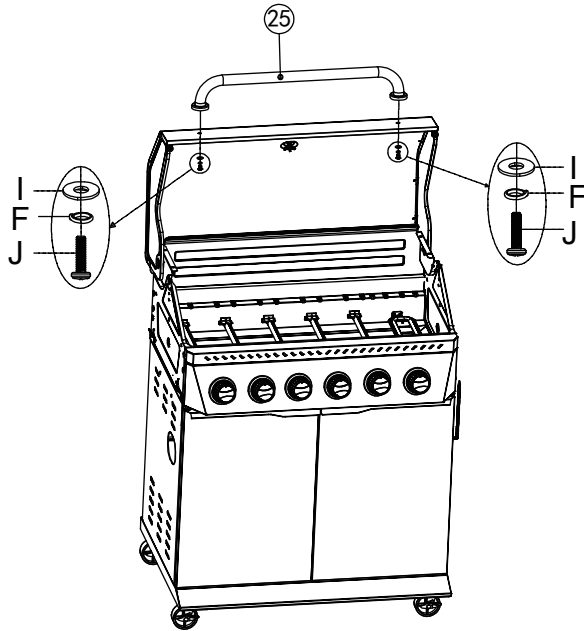

21	I		x2	J		x2
	F		x2			



22	K		x3	B		x2
	A		x5			

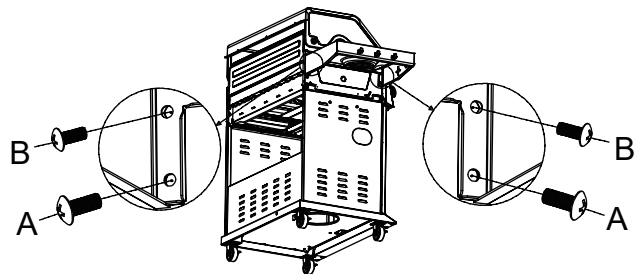
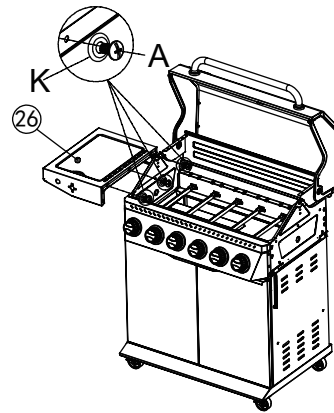

23	C		x2
----	---	---	----

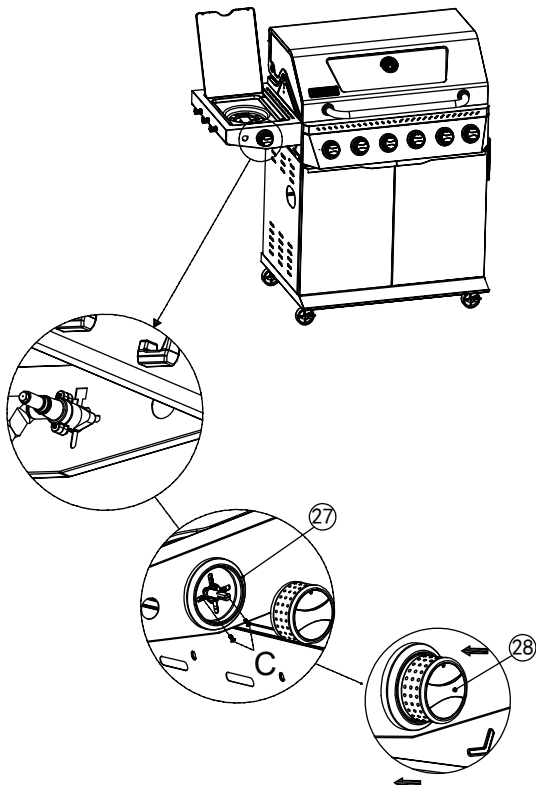

24			
----	--	--	--

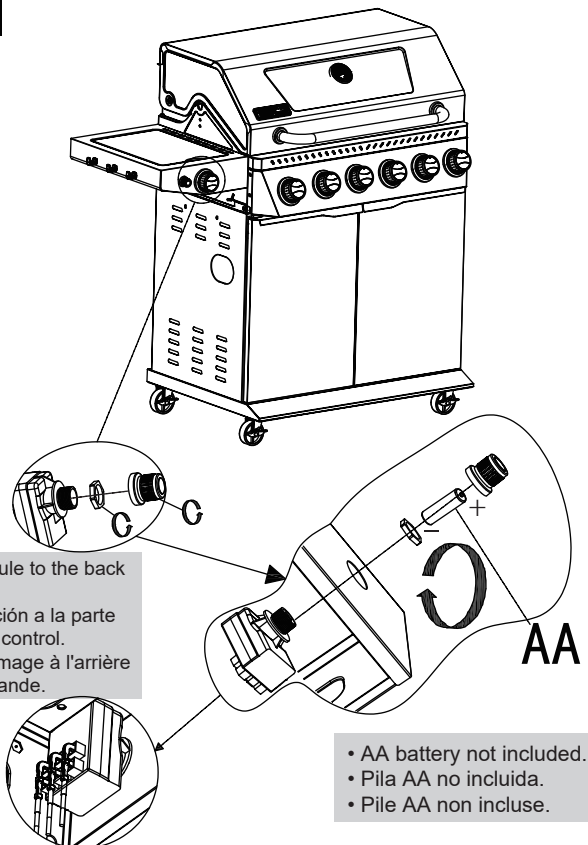

• Attach the igniter module to the back of the control panel.  
 • Fije el módulo de ignición a la parte posterior del panel de control.  
 • Fixez le module d'allumage à l'arrière du panneau de commande.

• AA battery not included.  
 • Pila AA no incluida.  
 • Pile AA non incluse.

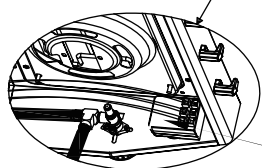
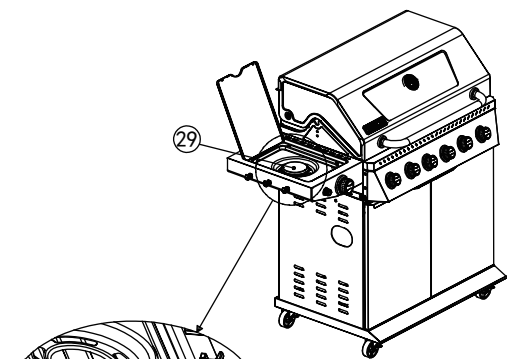

25 C  ×2

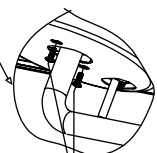
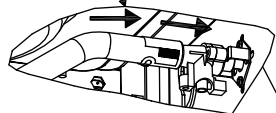

- Place the ignitor wire above the side burner tube.
- Coloque el cable de encendido sobre el tubo del quemador lateral.
- Placez le fil d'allumage au-dessus du tube du brûleur latéral.



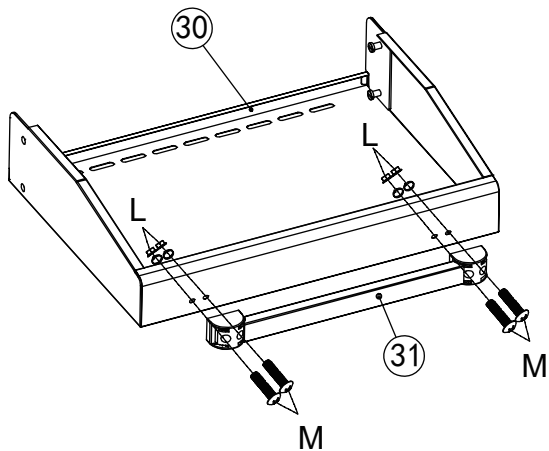

C

27 M  ×4  
L  ×4

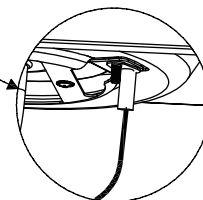
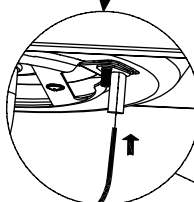
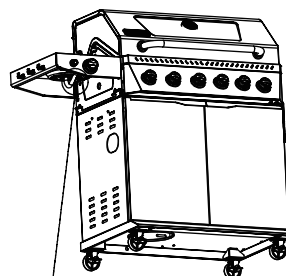

26



28 B  ×2  
A  ×2

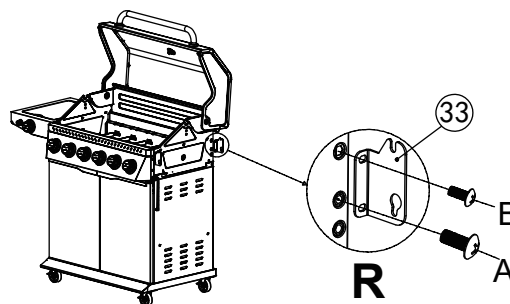
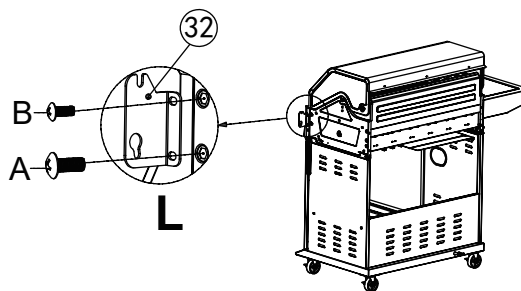

29

- Expand both sides of the side shelf and snap the screws into the brackets.
- Expanda ambos lados del estante lateral y encaje los tornillos en los soportes.
- Dépliez les deux côtés de l'étagère latérale et enclenchez les vis dans les supports.

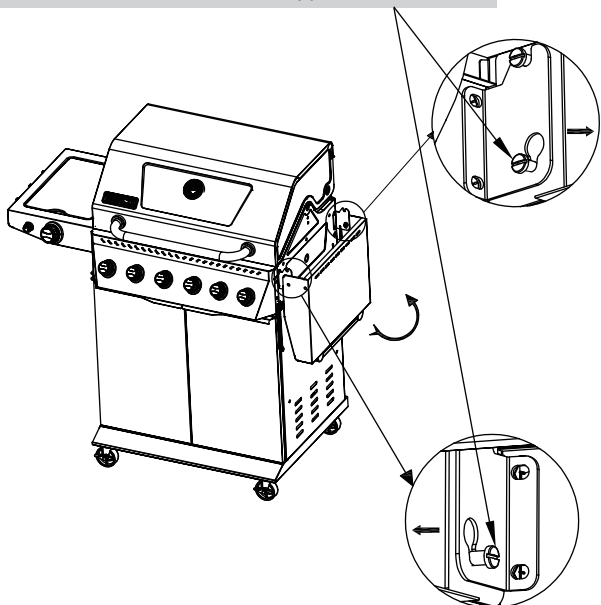

30

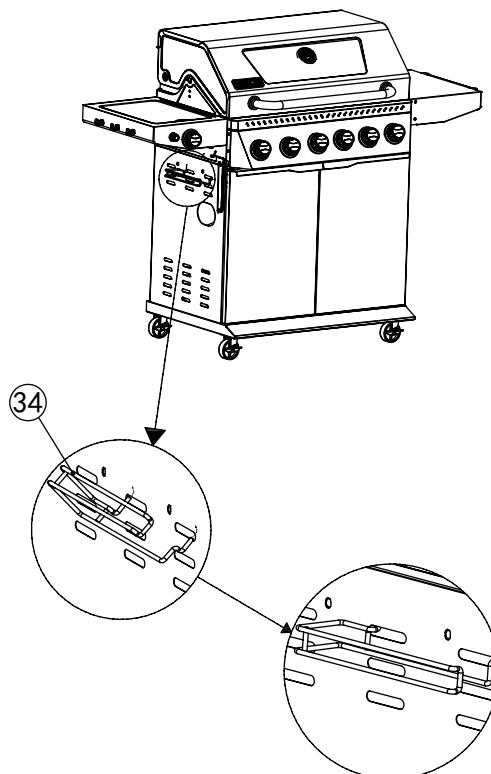

31

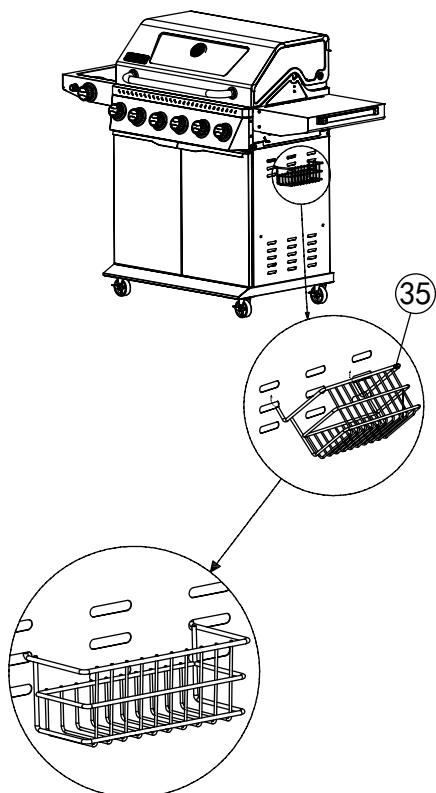

32

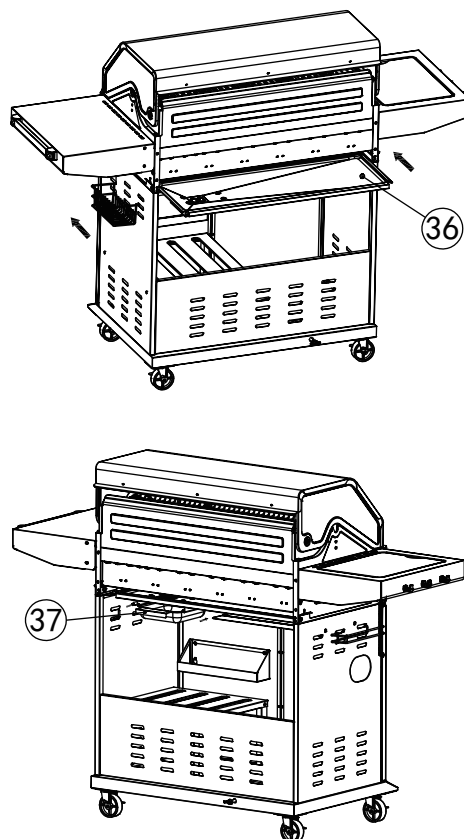

33

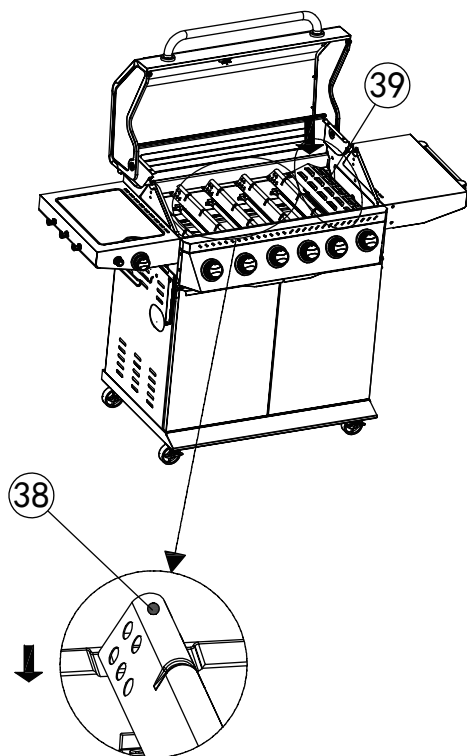

34

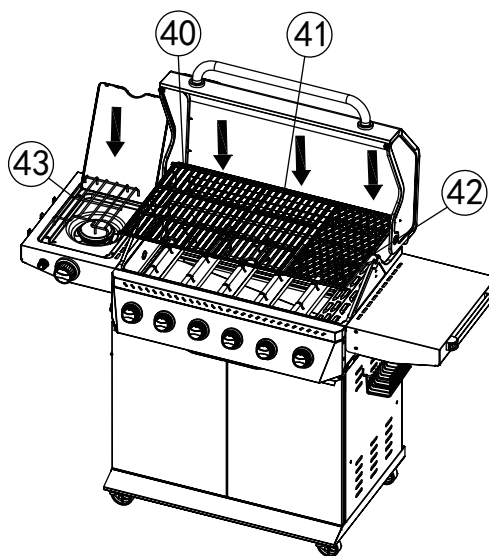

35

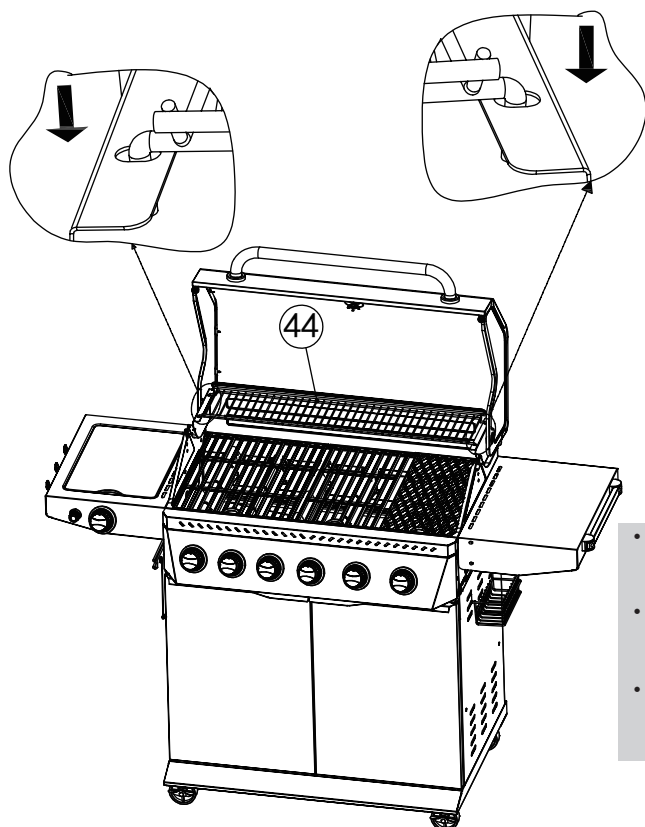

36

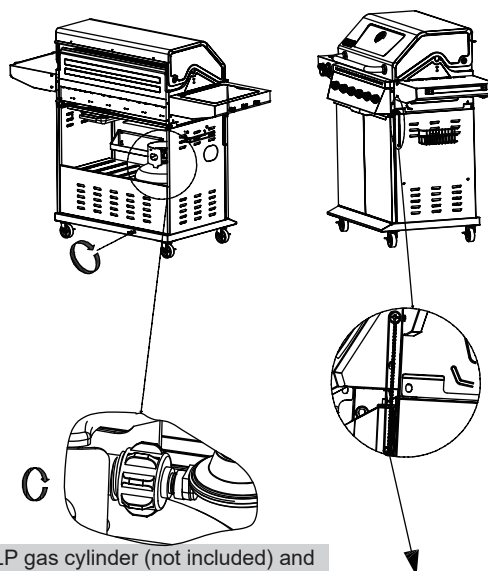

- Connect the LP gas cylinder (not included) and set it on the bottom shelf. Check the ignitor wire before using.
- Conecte el cilindro de gas LP (no incluido) y colóquelo en el estante inferior. Compruebe el cable del encendedor antes de usarlo.
- Connectez la bonbonne de gaz LP (non inclus) et placez-le sur l'étagère inférieure. Vérifiez le fil de l'allumeur avant de l'utiliser.

- Please hang the match-stick holder here after using.
- Cuelgue el soporte para cerillas aquí después de usarlo.
- Veuillez accrocher le porte-allumettes ici après utilisation.

**Thank You  
For Choosing Us.**

**Any Problem!  
We Can Help!**

**Customer  
Service**

**1-800-618-6798**

**Monday to Friday (8:30 am - 5:00 pm EST)**

**[service@royalgourmetusa.com](mailto:service@royalgourmetusa.com)**