

 HEAT STORM

User manual

Model: HS-3000-WALL-R

3000 W | Forced air | In-wall smart heater

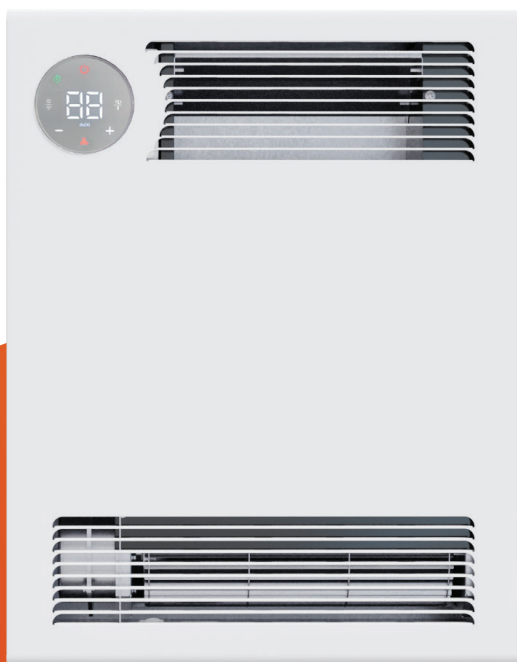

Table of contents:

Important instructions	3
Installation instructions	6
Operations & controls	13
Wi-Fi Setup	16
Troubleshooting guide	18
Return policy	20
1-year limited warranty	20

Thank you and congratulations on your Heat Storm Heater!
Please read and keep all safety and use instructions. Should you have any questions or concerns, please don't hesitate to reach out to us at 435-752-6611 or cs@heatstorm.com.

SPECIFICATIONS

Wattage: 3000	LxWxH: 15.51 x 4.92 x 19.88 inches
Amps: 25	Weight: 16.97 lbs
BTU: 10400	Decibels: 42-47
Voltage: 240V	Hardwired
CFM:	Heat settings: 2
Square footage: 300-1000 ft ²	Heating: Forced air

Important instructions

Please read and understand this entire manual before attempting to assemble, operate, or install the product. Use this heater only as described in the manual. If the directions are not followed, an electric shock or fire may result causing property damage, personal injury, or death.

SAFETY GUIDELINES

- Adhere to basic precautions to minimize the risk of fire, electric shock, and injury when using electrical appliances.
- The heater becomes hot during operation; avoid direct contact with hot surfaces to prevent burns.
- Exercise extreme caution in the presence of children, or individuals with reduced physical, sensory, or mental capabilities, or when the appliance is unattended. Children should not play with the appliance.
- Individuals with reduced capabilities should not operate the appliance without supervision or proper instruction.
- Unplug the heater when not in use for an extended period.
- The heater includes a thermostat limiter. If the inner temperature overheats or abnormal heating occurs, power will be cut off to prevent the risk of fire or heater damage.

WARNING

- For any maintenance please contact an authorized service representative.
- High temperature, risk of fire, keep electrical cords, drapery, furnishings, and other combustibles at least 3 feet (0.9 m) from the front of the heater and away from the side and rear. To reduce the risk of fire, do not store or use gasoline or other flammable vapors and liquids in the vicinity of the heater.
- Heat Storm Infrared Heaters are considered to be an appliance. Each heater and appliance should be on its own circuit.
- DO NOT operate if the following occurs:
 - » Heater has a damaged cord or plug.
 - » After the heater malfunctions.
 - » Heater has been dropped or damaged in any manner.Turn off the heater, disconnect the cord, and have heater inspected/serviced by an electrician before reusing or discard the heater.

CAUTION

- To prevent electric shock, match the wide blade of the plug to the wide slot and fully insert.
- Turn off and wait for the fan to stop before disconnecting.
- Do not insert foreign objects into ventilation or exhaust openings to prevent electric shock, fire, or heater damage.
- Do not block air intakes or exhaust.
- Under no circumstances should this heater be modified. Modifications will void the warranty. Parts removed for servicing must be replaced prior to operation.
- Hardwire or plug the heater directly into a wall outlet; do not use extension cords, surge protectors, or relocatable power taps. This heater is designed for a 240-volt power supply and should only be connected to a properly grounded power block.
- Ensure the cord is not under carpeting, covered with rugs, runners, or similar coverings. Avoid routing it under furniture or appliances and position it away from high-traffic areas to prevent tripping hazards.
- If the supply cord is damaged, it must be replaced by the manufacture, its service agent, or similarly qualified persons in order to avoid a hazard.
- Do not use in the following areas: outdoors, closets, or locations with gasoline, paint, or flammable liquids.
- To avoid excessive room temperatures which can cause hyperthermia: DO NOT leave product running unattended in a confined space around infants, or individuals with reduced physical, sensory, or mental capabilities.

BATTERY WARNING

- The remote contains a lithium button/coin cell battery. If a new or used lithium button/coin cell battery is swallowed or enters the body, it can cause severe internal burns and can lead to death in as little as 2 hours. If you think batteries have been swallowed or placed inside any part of the body, seek immediate medical attention. Call a local poison control center for treatment information.
- Even used batteries may cause severe injury or death.
- Remove and immediately recycle or dispose of used batteries according to local regulations and keep them away from children. Do NOT dispose of batteries in household trash or incinerate.
- Battery type Li-Mn CR2025 3.0V. Do not mix old and new batteries, different brands or types of batteries, such as alkaline, carbon-zinc, or rechargeable batteries.
- Non-rechargeable batteries are not to be recharged.
- Do not force discharge, recharge, disassemble, or heat above 140°F specified temperature rating or incinerate. Doing so may result in injury.
- Ensure the batteries are installed correctly according to polarity (+ and -).
- Remove and immediately recycle or dispose of batteries from equipment not used for an extended period of time according to local regulations.
- Always completely secure the battery compartment. If the battery compartment does not close securely, stop using the product, remove the batteries, and keep them away from children.

WARNING

- **INGESTION HAZARD:** This product contains a button cell or coin battery.
- **DEATH** or serious injury can occur if ingested.
- A swallowed button cell or coin battery can cause **Internal Chemical Burns** in as little as **2 hours**.
- KEEP new and used batteries **OUT OF REACH OF CHILDREN**
- **Seek immediate medical attention** if a battery is suspected to be swallowed or ingested inside any part of the body.



Installation instructions

Installation should be carried out by a certified electrician. Ensure that the heater is installed correctly before activating the power.

HEATER LOCATION

When choosing a location for your new heater, ensure that the general instructions are followed. Your heater must be properly installed prior to operation. Do not prop the heater up against objects or use the heater with the grill placed vertically. For best effect, install the heater out of direct sunlight.

Basement or garage use

The heater can be utilized in a finished basement with drywall and carpet. For other scenarios, consider Heat Storm Outdoor Infrared Heaters. Visit heatstorm.com for details.

Vaulted or cathedral ceilings

The heater can be used with vaulted or cathedral ceilings. However, initial room heating may take longer. Once the desired temperature is reached, the heater will cycle accordingly.

Poorly insulated areas

Note that rooms with poor insulation may not retain heat efficiently, potentially leading to longer or more frequent operation.

Cold climate installation note

Placing the unit under a window or on a poorly insulated wall may result in the heater reading a colder ambient temperature than the actual room temperature.

Heating multiple rooms

Effectiveness depends on floor plan openness and room sizes. Experiment to find the most suitable configuration.

NOTE: Designed for supplemental heating in spaces from 300 to 1000 square feet.

DO NOT USE in the following areas:

- Outdoors - use Heat Storm Outdoor Infrared Heaters
- Locations with gasoline, paint, or flammable liquids
- Wet or moist locations
- Closets

POWER CONNECTION GUIDELINES

Heat Storm Infrared Heaters are considered to be an appliance. Each heater and appliance should be on its own circuit.

The energy supply must be done through a properly grounded power block.

Plug the heater directly into a wall outlet; do not use extension cords, surge protectors, or relocatable power taps. This heater is designed for standard 240-volt outlets and should only be connected to a proper 3-prong polarized outlet.



CAUTION

High temperature, risk of fire, keep electrical cords, drapery, furnishings, and other combustibles at least 3 feet (0.9 m) from the front of the heater and away from the side and rear. To reduce the risk of fire, do not store or use gasoline or other flammable vapors and liquids in the vicinity of the heater.

TOOLS NEEDED FOR INSTALLATION

- Drywall saw
- Utility knife
- Wire cutter and stripper for hardwiring
- Philips screwdriver

Missing parts? Email us at cs@heatstorm.com

STEP 1: INSERT MOUNTING BRACKET

1-1 Select suitable wall

Ensure there is at least a 4½-inch clearance between the heater and the nearby walls, ceiling, and floor. Additionally, place the heater in a location where the cord can reach an outlet for power if it is not being hard wired.

1-2 Mark a 14⅞" (l) x 18 ⅞" (h) hole between two studs

Once you have measured, cut out the drywall.

Note: The mounting plate can be installed during new construction and the heater can be added after all finishing work is complete.

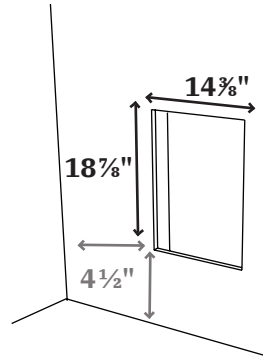

1-3 Secure mounting bracket

Insert the mounting bracket in the rectangular hole and screw it into the wood studs.

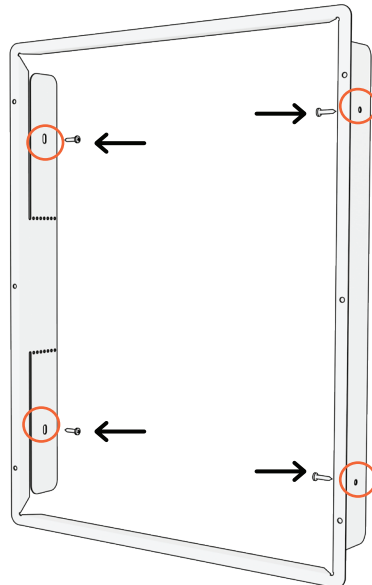
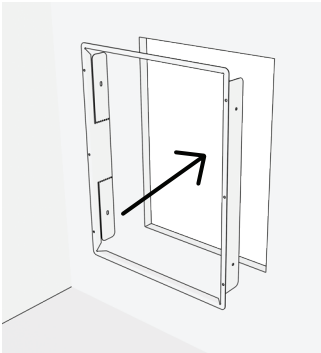

1-4

Remove heater grill

Remove front grill from heating base to prepare for install.

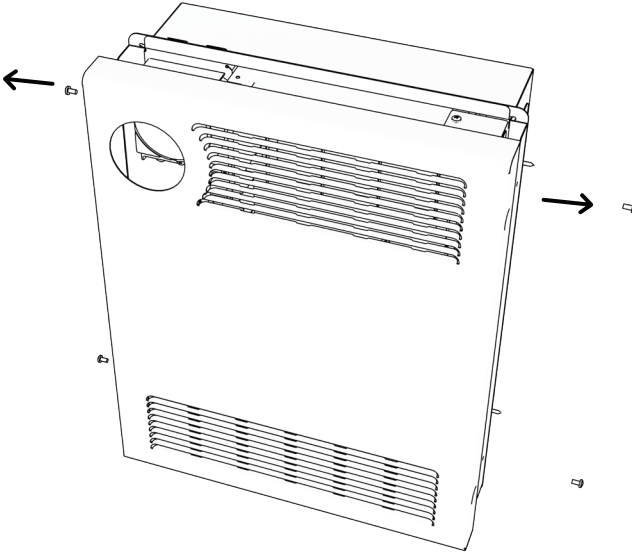

STEP 2: HARDWIRE HEATER

2-1

Remove power box cover

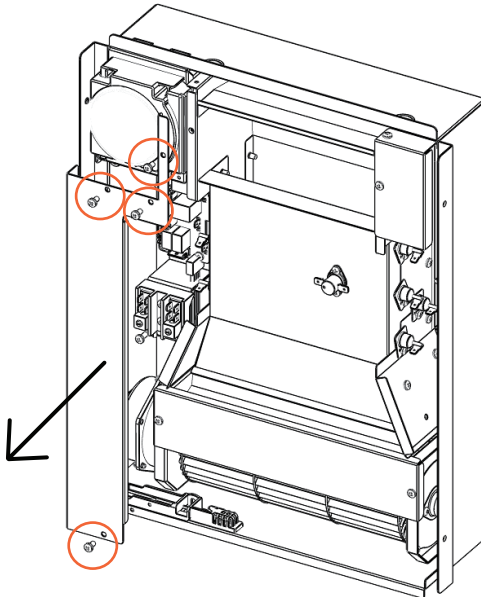

2-2

Remove hole cover at the bottom of the heater

Once removed, feed your wire into the box and ensure the wires are stripped and ready to connect.

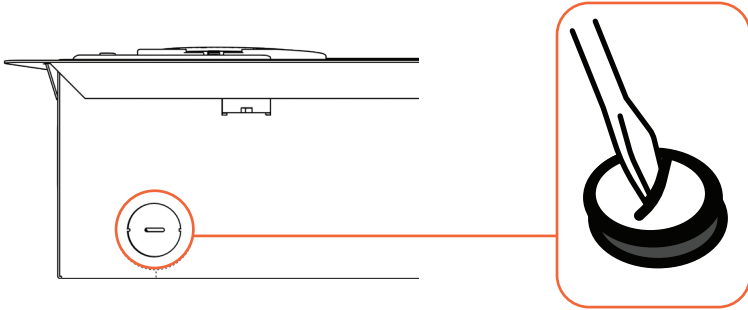

2-3

Connect wires

Connect the lines and the ground wire.

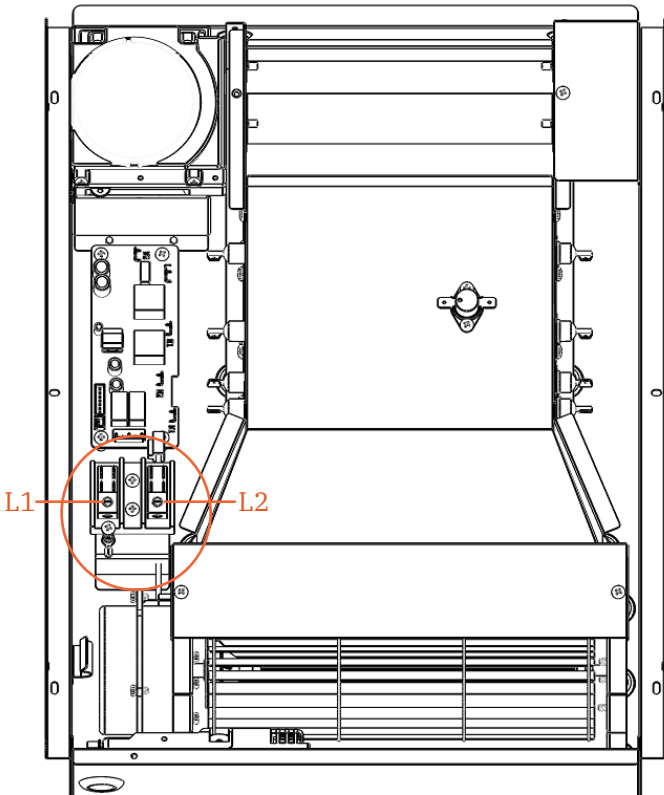

2-4 Replace power box cover

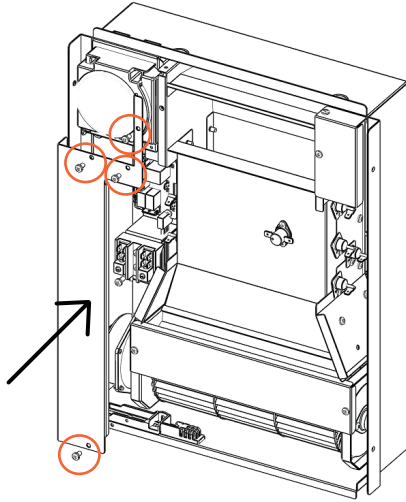

STEP 3: INSTALL HEATER

3-1 Install the heating base

Slide the heating base into the mounting bracket. Screw in place as shown.

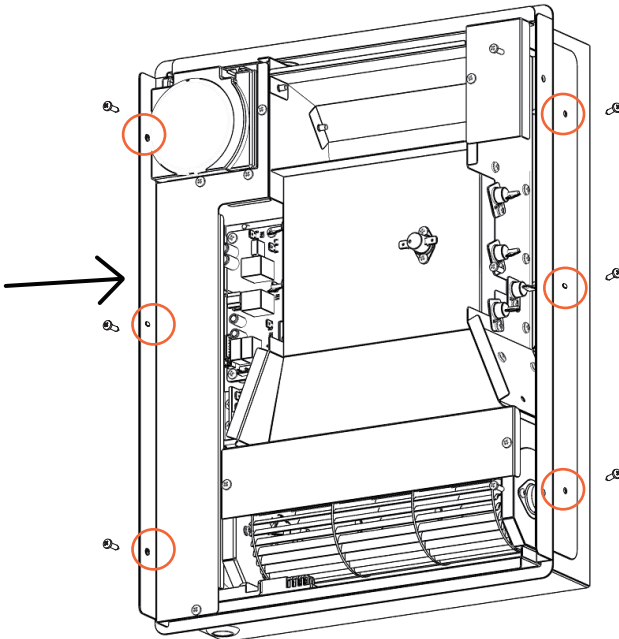

3-2 Attach the front grill

Screw the grill to the heating base using four screws.

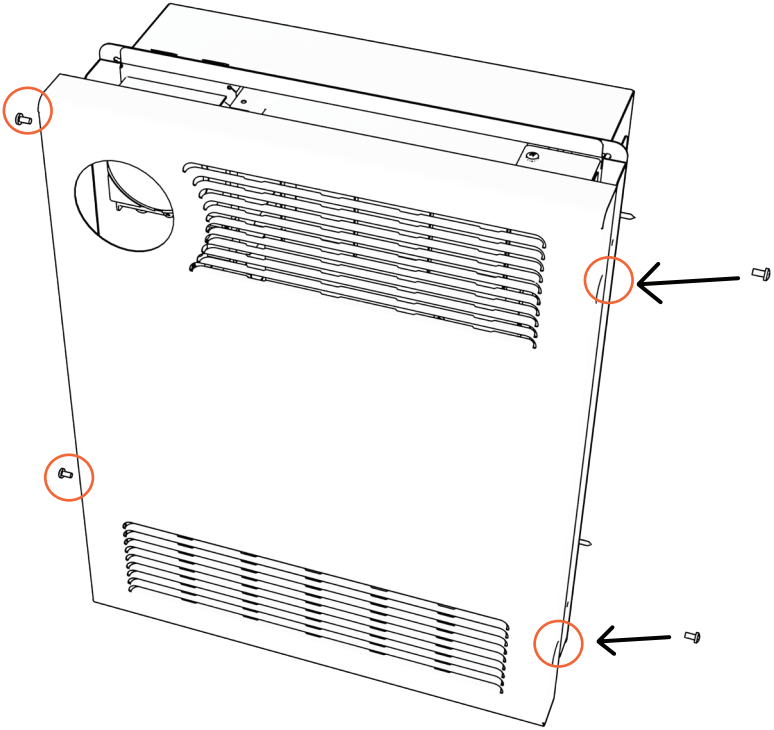

Operations & controls



Power ON/OFF

Press the power icon to alternate between on (red) and off (white).

Child lock

Press and hold the power icon for 5 seconds to engage/disengage child lock. When the child lock is on a red lock icon will appear and no changes can be made to the settings until the child lock is turned off.

Factory reset

Power off heater and allow time for elements to cool. Unplug and plug in heater. Within 3 minutes of plugging in heater, press and hold power icon for 10 seconds to reset the heater to factory settings.



Timer

When the heater is off, you can set both delay on and delay off time. Tap on the timer icon to enable edit mode. The display will flash. Use the plus and minus icons to change the "on" time (hour increments).

Tap the timer icon again to set the "delay off" timer. Follow the same instructions above to add or take away time. Wait 5 seconds for the timer setting to activate.

NOTE: When the heater is on, you can only set the "delay off" timer.

- **No timer set | White**
 - **Timer set for off | Green**
 - **Timer set for on | Red**
-

Setting the temperature

The default temperature for the heater is 70 °F or 21 °C. Pressing the + or - icons enters temperature setting mode, where the thermostat can be adjusted by 1 °F or 1 °C. The display exits this mode after 5 seconds of inactivity, showing the current ambient temperature.





NOTE: After the heater function or power is turned off, the blower will continue for several minutes to cool internal components.

Selecting Celsius & Fahrenheit

Press the + and - icons at the same time to switch between Celsius and Fahrenheit.

NOTE: Switching between °C and °F can only be performed using the control panel on the heater, and is not available using the remote control.



Change working mode

Press the fan button to toggle between low, auto, and high working modes.

- **Low mode* | Green**
Heater operates at 50% power, effectively halving the wattage. This is beneficial for situations where the breaker tends to trip easily or when heating a small space.
- **Auto mode (Eco mode) | White**
Heater runs at full power until it's within 2 degrees of the set temperature. It then shifts to 50% power to achieve and maintain the desired temperature. This ensures more frequent, energy-efficient operation while effectively maintaining the set temperature.
- **High mode* | Red**
Heater runs at 100% power until desired temperature is met.

NOTE: The fan will turn on and off to circulate air. The heater is trying to determine if the ambient temperature in the room has changed.

**Low and high modes will reach the set temperature, followed by a 2-degree cooling period before reheating.*

Fan only/heat mode

Press and hold the fan button for 3 seconds to toggle between fan only (blue fan icon) and heat mode (red icon).



Sound

Press the volume/thermostat symbol to alternate between sound on/off.



Pair external thermostat



Press and hold both the power/thermostat button on the heater for 5 seconds. The light will begin blinking red, indicating it's in discovery mode. Next, press and hold the button on the back of the external thermostat for 5 seconds until you hear a beep. Once paired, the thermostat indicator light will glow red, confirming a successful connection.



Display brightness

Tap on the Wi-Fi/sun symbol to change the display brightness.

Wi-Fi discovery mode

Press and hold the sun/Wi-Fi symbol for 5 seconds to enable the Wi-Fi discovery mode (will blink blue). Refer to page 16 for guidance on connecting to Wi-Fi. The blinking blue light will turn to a solid blue once Wi-Fi is connected.

REMOTE CONTROL

The remote will function the same as the buttons on your unit. If you have any questions on how a function works, please refer to the previous control descriptions.

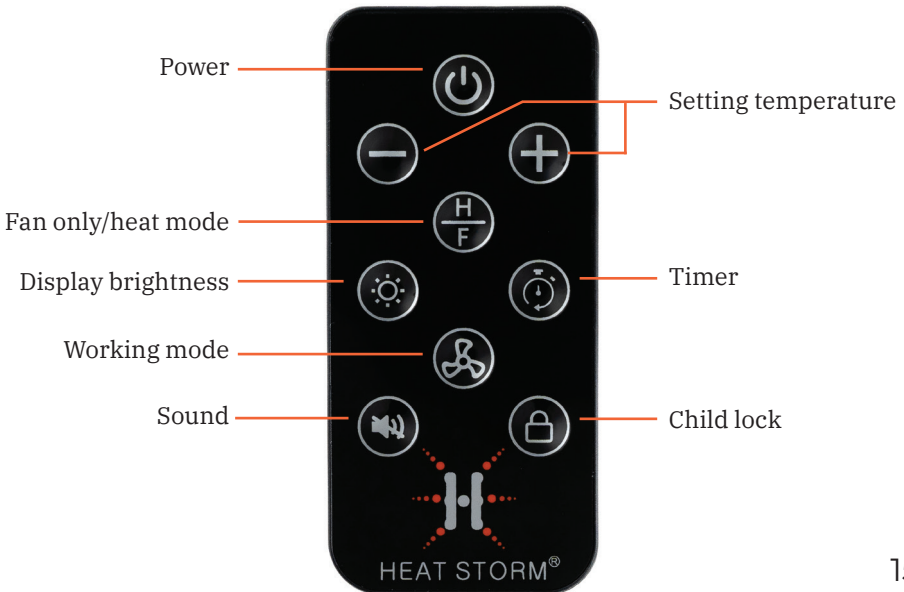

Wi-Fi® setup



SMART LIFE APP

Manage your Heat Storm Smart Heater conveniently anytime and anywhere you desire. With just a tap of your finger, you can adjust temperatures, create schedules, set a child lock, and ensure warmth according to your preferences.

Prepare your phone

Enable Wi-Fi and Bluetooth® on your phone. Connect to your phone to a 2.4 GHz Wi-Fi network. Your phone needs to be connected to the same Wi-Fi that you want to connect your heater to.

NOTE: for some dual band routers, you may need to manually create a network dedicated to 2.4 GHz.

Download the Smart Life App

Download the app by scanning the QR code or search for Smart Life in the App Store or on Google Play. Once the app is downloaded, sign up, and agree to the User Agreement and Privacy Policy.



Register with your email, set your password, and create a new home in the Smart Life app.

CONNECT YOUR HEATER TO WI-FI

The Smart Life app offers multiple methods for Wi-Fi setup. If one method fails, don't worry—simply move on to the next one.

It's essential to note that the app might undergo updates over time. As a result, the app prompts you encounter may differ slightly from the manual. For the most accurate and up-to-date guidance, follow the prompts within the app.

Need help?

Visit heatstorm.com/wifi for video tutorials and helpful tips.

EASY CONNECT

**Ensure your phone's Wi-Fi, Bluetooth®, and location functions are all activated.*

1 Add device

When the machine is on, press and hold the Wi-Fi/sun button on the control panel for 5 seconds until the Wi-Fi indicator light begins flashing slowly. Add the appliance in the app:

- i. If a pop-up is displayed, tap "Go to add". If you don't get a pop-up, tap the plus icon in the top right corner. Select "Add device."
- ii. Choose "small home appliance," then find "Heater (BLE) .

2 Choose Wi-Fi

Enter your case-sensitive Wi-Fi network name and password, then tap "Confirm." Press "Next" if prompted to reset the heater.

3 Configuration process

Wait for the connection to be completed. Please be patient, as this may take a few minutes. The app will notify you that the device was successfully added. Select "done" to enter the control interface.

MANUAL CONNECT

1 Add device

- i. When the machine is on, press and hold the Wi-Fi/sun button on the control panel for 5 seconds until the Wi-Fi indicator light begins flashing.
- ii. In the app, tap the plus icon in the top right corner.
- iii. Select "Add device." Choose "Small home appliance."
- iv. Tap "Heater (Wi-Fi)."

2 Choose Wi-Fi

Enter your case-sensitive Wi-Fi network name and password, then tap "Confirm." Press "Next" if it is asking you to reset your heater.

3 Configuration mode

Confirm the Wi-Fi indicator light on control panel is flashing quickly and select "blinking quickly" within the app. Then click on "Finish network configuration".

4 Configuration process

Wait for the connection to be completed. Please be patient, as this may take a few minutes. The app will notify you that the device was successfully added. Select "done" to enter the control interface.

Troubleshooting guide

RECALIBRATING YOUR HEATER

If your heater is not working like normal, try resetting it. Heaters are like other electronics, sometimes they need a reboot (refer to the factory reset on page 13). If an issue persists, contact customer service at 435-752-6611.

FAN

Not blowing air

When powering the heater ON, it does not blow any air at first. The initial 15 seconds allow the infrared elements to heat up, ensuring that when the fan turns on, warm air is circulated into the room.

Not blowing warm air

- Ensure the air inlet is not blocked.
- The ambient temperature (displayed) is higher than the thermostat setting.
- There is something blocking the air flow. Move the object out of the way of the heater. This is common if the heater is in a closet or under a desk.

Continuing to blow air when heater is turned off

This is the cool down phase. The heater will run for several minutes (up to 12) to cool the internal components. This increases the lifespan of the infrared elements. If the heater did not finish the cooling procedure when it was unplugged, the fan will blow immediately when the heater is powered back on.

Heater fails to reach the set temperature and continues to run.

Possible reasons for temperature discrepancies:

1. Ensure clean filters.
2. Address drafty or poorly insulated rooms.
3. Keep doors closed for efficient heating.
4. Place the heater on an interior wall, away from windows.
5. If issues persist, consider the heater's size suitability for the room. Optimal for spaces between 300-1000 sq. ft., with primary heating around 300 sq. ft.*

**Square footage recommendations may vary based on home insulation.*

Placing the heater near objects can impede air circulation in the room, resulting in uneven temperatures within the same space.

Unplug the unit from the wall outlet for 2 hours. Reconnect the unit after this period. If the issue persists, contact customer service at 435-752-6611.

Fan runs for under a minute and then turns off

The fan is turning on to attempt to create air flow within your room. The heater is trying to determine if the ambient temperature in the room has changed.

THERMOSTAT

Ambient temperature reading of the heater different then the reading on my central heating thermostat.

Thermostat readings may fluctuate depending on the surroundings. You can manually calibrate the thermostat on the heater to align with your central HVAC system. You may need to attempt calibration multiple times to align your heater thermostat with your HVAC system.

1. In the Smart Life app, tap on your heater to enter the temperature adjusting screen. Press the  icon to enter the temperature setting page.
2. Adjust the Heat Storm's thermostat with the slider to reach the same temperature as your central HVAC.

NOTE: Generally, Heat Storm heater thermostats are more precise than home central thermostats. Adjusting your Heat Storm heater to align with your central system may result in reduced efficiency.

BURNING PLASTIC SMELL

A light plastic odor is normal for new, unused heaters. If the smell persists for more than a couple of hours, call customer service at 435-752-6611.

ERROR CODES

EE : Temperature sensor (probe) error, when this code shows, the heating element and fan are turned off. Unplug heater and check if the temperature sensor is loose, disconnected, or damaged.

EO : Program setup failure. Unplug and plug in again. If error persists, the PCBA needs to be replaced.

UH: Incorrect high voltage power supply error. Unplug heater immediately. Attempt plugging the heater into a different outlet and ensure it is the sole major appliance on the circuit.

LO: The temperature is less than 16° F (-9 °C)

HI: The temperature is greater than 99° F (37°C)

Returns & exchanges

Eligibility

Returns are available for items purchased from heatstorm.com if the following conditions are met:

1. Returned within 30 days of receiving the order.
2. In new condition with the original packaging with manuals and accessories.
3. Proof of purchase is provided.

Shipping & fees

- Return shipping is the customer's responsibility.
- Original shipping charges and handling fees will be deducted from the refund.
- A 20% restocking fee applies for returns beyond 30 days.
- Shipping costs for Canadian orders are non-refundable.

1-year limited warranty

The manufacturer warrants this product and included accessories against defects in materials and workmanship under normal use for a period of ONE (1) YEAR from the date of retail purchase by the original end-user purchaser.

EXCLUSIONS AND LIMITATIONS

1. Install and operate the electric heater strictly in accordance with the provided instructions at all times. Unauthorized repairs, alterations, willful abuse, accidents, or misuse of the product will void this warranty.
2. This warranty is exclusive to the original owner, valid only if the purchase was made through an authorized supplier of the product, and is non-transferable.
3. The warranty is limited to repairing or replacing defective parts in material or workmanship. This applies only if the said part(s) have been exposed to normal conditions of use and service, confirmed by the manufacturer's inspection.
4. The manufacturer may, at its discretion, fulfill warranty obligations by refunding the wholesale price of the defective part(s).

5. Costs related to installation, labor, construction, transportation, or any other associated expenses arising from defective part(s), repair, replacement, or otherwise, are not covered by this warranty. The manufacturer disclaims responsibility for such costs.
6. The owner/user assumes all risks, including any direct, indirect, or consequential loss or damage resulting from product use, except as mandated by law.
7. All other warranties, whether expressed or implied, pertaining to the product, its components, accessories, or any manufacturer obligations/liabilities, are expressly excluded. The manufacturer neither assumes nor authorizes any third party to assume additional liabilities related to the product sale.
8. The manufacturer neither assumes nor authorizes any third party to assume on its behalf, any other liabilities with respect to the sale of the product.
9. The warranties as outlined in this document do not apply to non-accessories used in conjunction with the installation of this product.
10. Specific legal rights provided; additional rights may vary by state. Warranty void if prolonged exposure to dampness, unauthorized alteration, willful abuse, accident, misuse, or lack of original purchase receipt.

WARRANTY REDEMPTION

Reach out to Heat Storm customer service at 435-752-6611 during the warranty period. Please have your sales receipt, purchase location, and product model information ready. Troubleshooting support will be offered over the phone. If the issue persists, you may be requested to email proof of purchase and a photo of the manufacturer sticker to cs@heatstorm.com.

Replacement parts:

In some cases, we may send you a replacement part along with repair instructions. This is classified as an authorized repair and does not void your warranty.

Unit repairs:

If the situation warrants, we will have you send the defective product to us for inspection. Our technicians will repair the product or provide a new unit if your heater is deemed irreparable. For units beyond the 30-day return policy, shipping costs are the consumers responsibility. If interested in our discounted shipping rates, kindly inform your customer service representative.



Need help?

435-752-6611

cs@heatstorm.com

heatstorm.com