

SERVICE MANUAL

BUCK 550-4 24.0

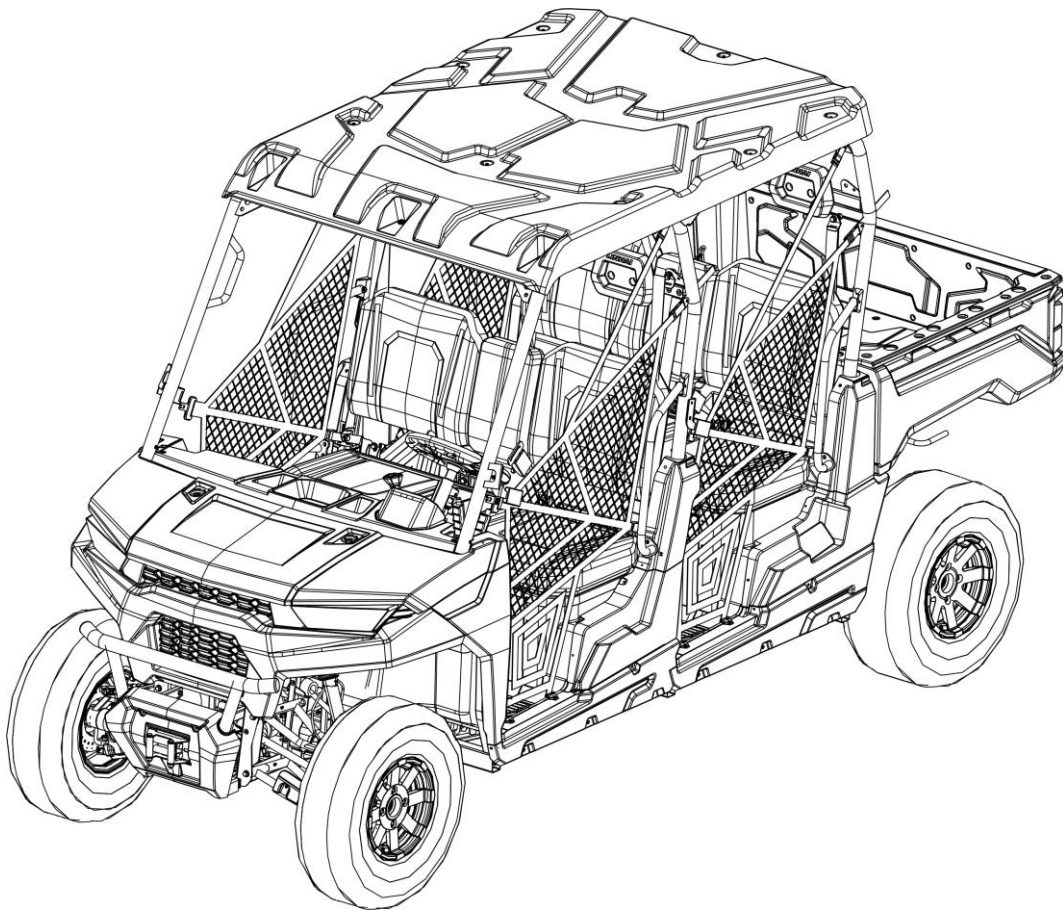

NOTICE

This manual was produced by the Linhai Group primarily for use by Linhai dealers and their qualified mechanics. It is not possible to include all the knowledge of a mechanic in one manual, so it is assumed that anyone who uses this book to perform maintenance and repairs on Linhai vehicle has a basic understanding of the mechanical ideas and the procedures of vehicle repair. Repairs attempted by anyone without this knowledge are likely to render the vehicle unsafe and unfit for use.

Linhai Group is continually striving to improve all its models. Modifications and significant changes in specifications or procedures will be forwarded to all authorized Linhai dealers and will appear in future editions of this manual where applicable.

NOTE:

Designs and specifications are subject to change without notice.

IMPORTANT INFORMATION

Particularly important information is distinguished in this manual by the following notations.



The Safety Alert Symbol means ATTENTION! BECOME ALERT! YOUR SAFETY IS INVOLVED!

WARNING

Failure to follow WARNING instructions could result in severe injury or death to the vehicle operator, passenger, a bystander, or a person checking or repairing the vehicle.

CAUTION:

A CAUTION indicates special precautions that must be taken to avoid damage to the vehicle.

NOTE:

A NOTE provides key information to make procedures easier or clearer.

CONTENTS

CHAPTER1	<i>General Information</i>
CHAPTER2	<i>Maintenance</i>
CHAPTER3.....	<i>Engine</i>
CHAPTER4.....	<i>Chassis</i>
CHAPTER5.....	<i>Final Drive</i>
CHAPTER6.....	<i>Brakes</i>
CHAPTER7.....	<i>Electrical</i>

 **WARNING**

Never run an engine in an enclosed area. Carbon monoxide exhaust gas is poisonous and can cause severe injury or death. Always start engines outdoors.

Gasoline is extremely flammable and explosive under certain conditions. Battery electrolyte is poisonous. It contains sulfuric acid. Serious burns can result from contact with skin, eyes or clothing. Always keep alert and wear protection.

Exhaust system components are very hot during and after use of UTV. Never service when the engine is warm or hot. Escaping steam from cooling system or hot oil from the machine can cause severe burns. The engine must be cool before service.

Crate of the UTV and parts in the UTV maybe have sharp edge, always pay attention and wear protection.

CHAPTER 1 GENERAL INFORMATION

WARNING

The parts of different types/ variants/ versions maybe un-interchangeable, even some parts have almost same appearance. Always refer to Parts Manual of each UTV model for spare parts information and service.

1.1 IMPORTANT INFORMATION

1.2 V.I.N AND ENGINE SERIAL NUMBER

1.3 VEHICLE DIMENSIONS

1.1 IMPORTANT INFORMATION

PREPARATION FOR REMOVAL PROCEDURES

1. Remove all dirt, mud, dust and foreign material before removal and disassembly.
2. Use proper tools and cleaning equipment.
3. When disassembling the machine, always keep mated parts together. This includes gears, cylinders, pistons and other parts that have been "mated" through normal wear. Mated part must always be reused or replaced as an assembly.
4. During machine disassembly, clean all parts and place them in trays in the order of disassembly. This will speed up assembly and allow for the correct installation of all parts.
5. Keep all parts away from any source of fire.

REPLACEMENT PARTS

Use only genuine parts for all replacements. Use recommended oil and grease for all lubrication jobs. Other brands may be similar in function and appearance, but inferior in quality.

GASKETS, OIL SEALS AND O-RINGS

1. Replace all gaskets seals and O-rings when overhauling the engine. All gasket surfaces, oil seal lips and O-rings must be cleaned.
2. Properly oil all mating parts and bearings during reassembly. Apply grease to the oil seal lips.

LOCK WASHERS/PLATES AND COTTER PINS

Replace all lock washers/plates and cotter pins after removal. Bend lock tabs along the bolt or nut flats after the bolt or nut has been tightened to specification.

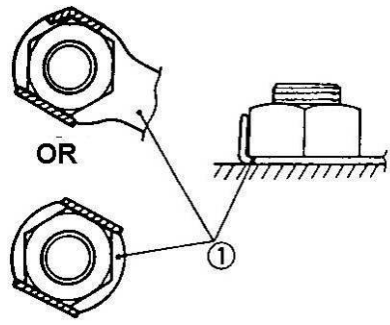

BEARINGS AND OIL SEALS

Install bearings and oil seals so that the manufacturer's marks or numbers are visible. When installing oil seals, apply a light coating of lightweight lithium base grease to the seal lips. Oil bearings liberally when installing, if appropriate.

① oil seal

CAUTION:

Do not use compressed air to spin the bearings dry. This will damage the bearing surfaces.

① Bearing

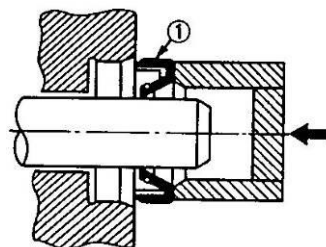

CIRCLIPS

1. Check all circlips carefully before reassembly. Always replace piston pin clips after one use. Replace distorted circlips. When installing a circlip ①, make sure that the sharp-edged corner ② is positioned opposite the thrust ③ it receives. See sectional view.

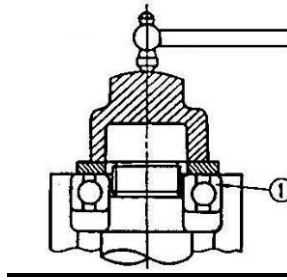

④ Shaft

CHECKING OF CONNECTIONS

Dealing with stains, rust, moisture, etc. on the connector.

1. Disconnect:
 - Connector
2. Dry each terminal with an air blower.
3. Connect and disconnect the connector two or three.
4. Pull the lead to check that it will not come off.
5. If the terminal comes off, bend up the pin ① and reinsert the terminal into the connector.
6. Connect:
 - Connector

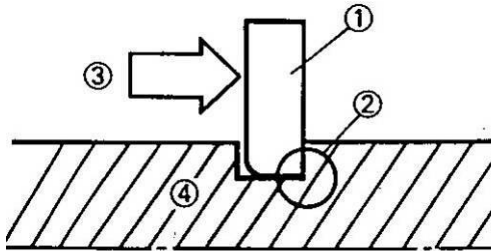

NOTE:

The two connectors "click" together.

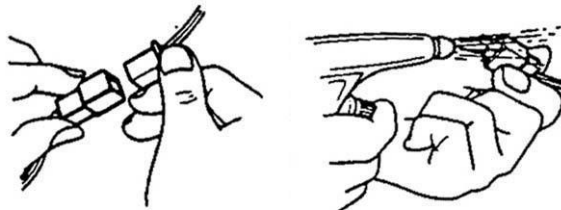

7. Check for continuity with a tester.

NOTE:

- If there is no continuity, clean the terminals.
- Be sure to perform the steps 1 to 7 listed above when checking the wire harness.
- Use the tester on the connector as shown.

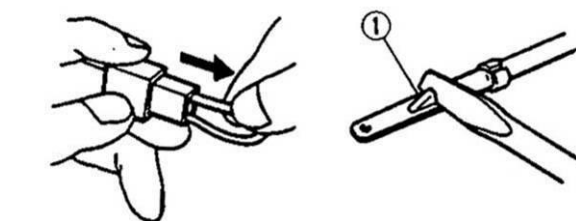

⚠ WARNING

Never run an engine in an enclosed area. Carbon monoxide exhaust gas is poisonous and can cause severe injury or death. Always start engines outdoors.

Gasoline is extremely flammable and explosive under certain conditions. Battery electrolyte is poisonous. It contains sulfuric acid. Serious burns can result from contact with skin, eyes or clothing. Always keep alert and wear protection..

Exhaust system components are very hot during and after use of UTV. Never service when the engine is warm or hot. Escaping steam from cooling system or hot oil from the machine can cause severe burns. The engine must be cool before service.

Crate of the UTV and parts in the UTV maybe have sharp edge, always pay attention and wear protection.

CONVERSION TABLE

How to use the CONVERSION TABLE

Use this table to convert METRIC unit data to IMPERIAL unit data.

Ex.

METRIC		MULIPLIER	=	IMP
**mm	x	0.3937	=	**in
**cm	x	0.03937	=	**in

CONVERSION TABLE

METRIC TO IMP			
	Known	Multiplier	Result
Torque	m • kg	7.233	ft • lb
	m • kg	86.794	ln • lb
	cm • kg	0.0723	ft • lb
	cm • kg	0.8679	ln • lb
Weight	kg	2.205	lb
	g	0.03527	oz
Distance	km/h	0.6214	mph
	km	0.6214	mi
	m	3.281	ft
	m	1.094	yd
	cm	0.3927	in
	mm	0.03927	in
Volume/ Capacity	cc(cm ³)	0.03527	oz(IMP liq.)
	cc(cm ³)	0.06102	cu • in
	lit(liter)	0.8799	qt (IMP liq.)
	lit(liter)	0.2199	gal(IMP liq.)
Miscellaneous	kg/mm	55.997	lb/in
	kg/cm ²	14.2234	psi(lb/in ²)
	Centigrade	9/5(°C)+32	Fahrenheit(° F)

1.2 V.I.N AND ENGINE SERIAL NUMBER

The vehicle identification number ① is stamped into the rear right of the frame tube.

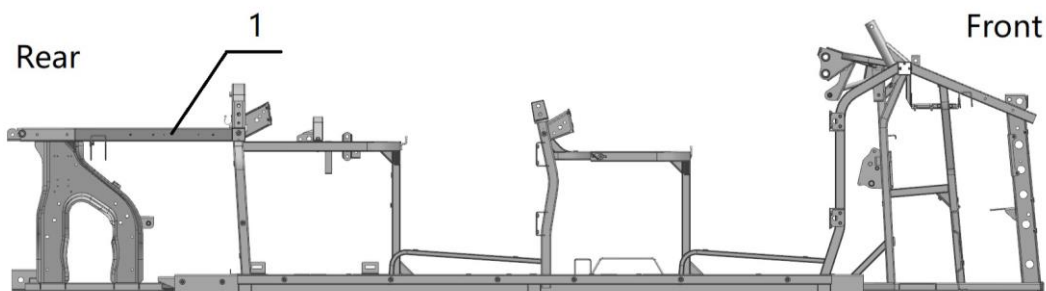

The engine serial number ② is stamped into left side of engine crankcase.

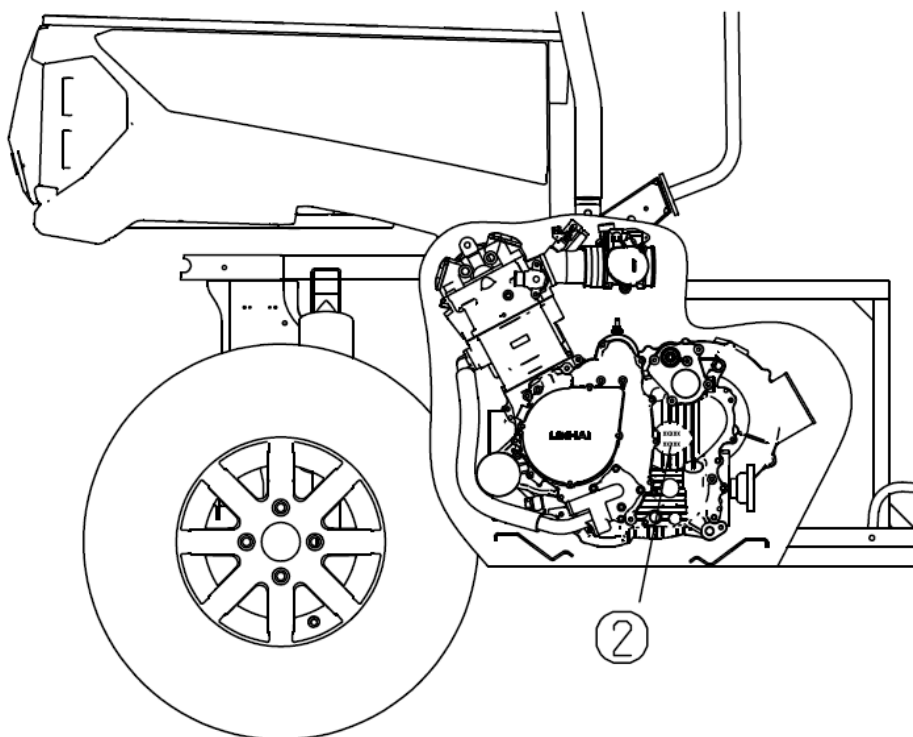

1.3 VEHICLE DIMENSIONS

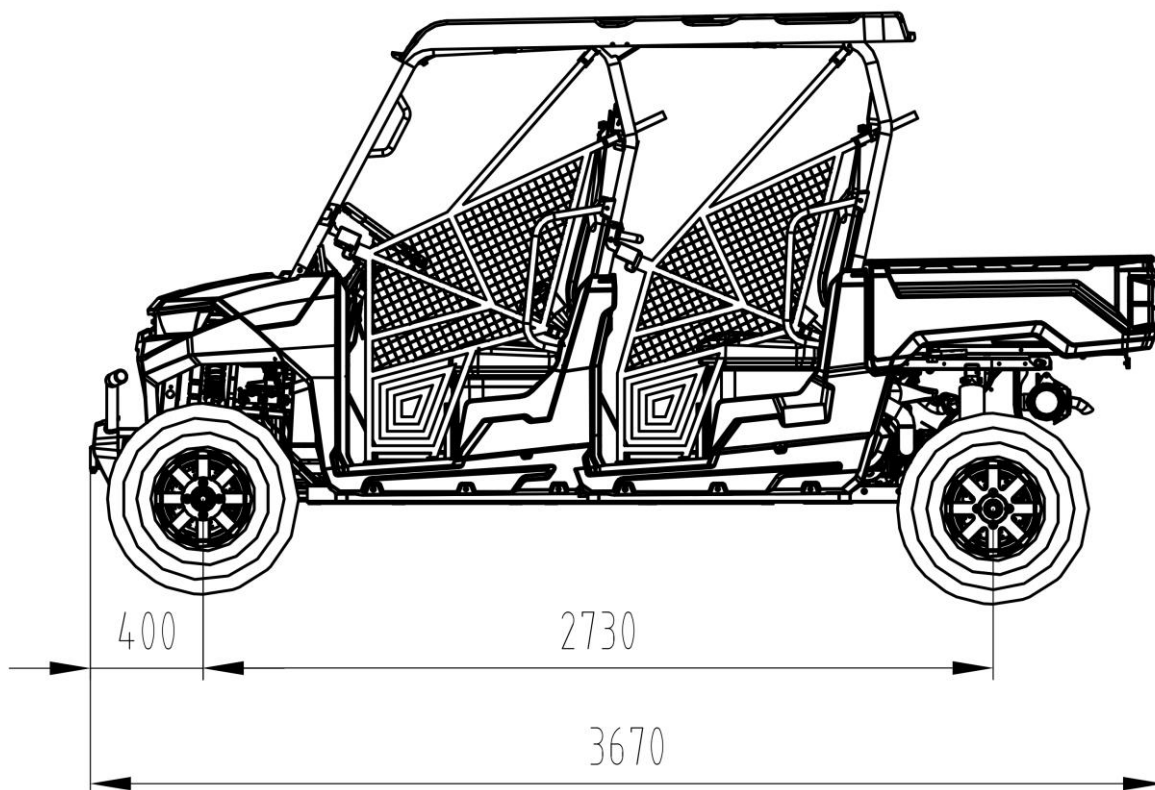
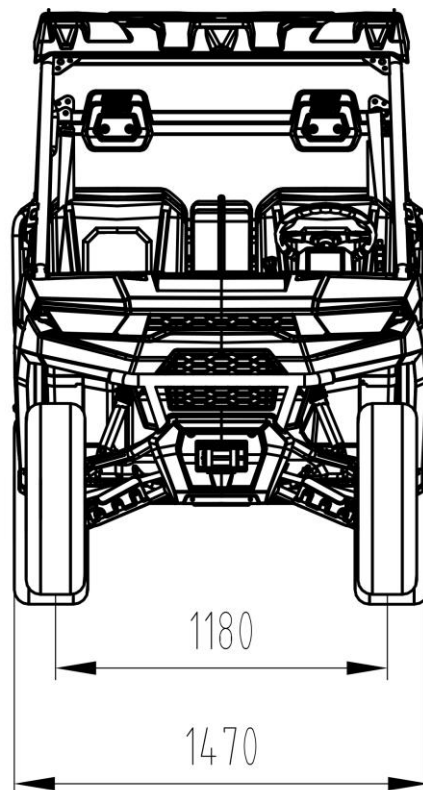
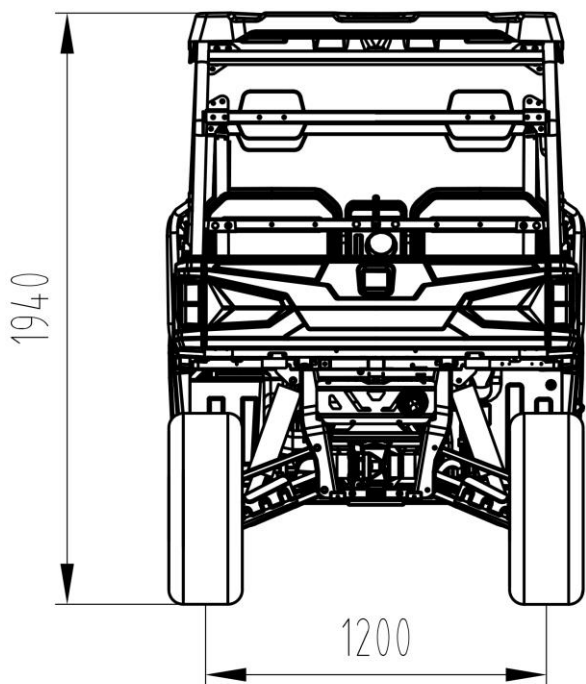

CHAPTER 2 MAINTENANCE

 WARNING

The parts of different types/ variants/ versions maybe un-interchangeable, even some parts have almost same appearance. Always refer to Parts Manual of each UTV model for spare parts information and service.

2.1 PERIODIC MAINTENANCE

2.2 THROTTLE PEDAL INSPECTION

2.3 CHOKE ADJUSTMETN

2.4 FUEL SYSTEM

2.5 TOE ALIGNMENT

2.6 BRAKING SYSTEM INSPECTION

2.7 SUSPENSION SPRING RPELOAD ADJUSTMENT

2.8 WHEELS

2.9 TIRE PRESSURE

3.0 FRAME, NUTS, BOLTS, FASTENERS

2.1 PERIODIC MAINTENANCE

GENERAL

CAUTION

Mark on the following chart

DL : Due to the nature of the adjustments marked with a **DL** on the following chart, it is recommended that service be performed by an authorized dealer.

▲ : Service/Inspect more frequently when operating in adverse conditions.

PERIODIC MAINTENANCE SCHEDULE

Careful periodic maintenance will help keep your vehicle in the safest, most reliable condition. Inspection, adjustment and lubrication intervals of important components are explained in the following chart on the following pages.

Maintenance intervals are based upon average riding conditions and an average vehicle speed of approximately 16km/h (10 miles per hour). Vehicles subjected to severe use, such as operation in wet or dusty areas, should be inspected and serviced more frequently.

Inspect, clean, lubricate, adjust or replace parts as necessary.

NOTE: Inspection may reveal the need for replacement parts. Always use genuine parts available from your dealer.

Service and adjustments are critical. If you are not familiar with safe service and adjustment procedures, have a qualified dealer perform these operations.

- A = Adjust I = Inspect
- C = Clean L = Lubricate
- D = Drain R = Replace
- T =Tighten to Correct Torque

	Item	Hours	When	Remarks
	Service (Main) Brake System	/	Pre-ride	I
	Parking Brake	/	Pre-ride	I
	Tires	/	Pre-ride	I
	Wheels	/	Pre-ride	I
	Frame nuts, bolts fasteners	/	Pre-ride	I
▲	Air Filter-Pre-Cleaner	/	Daily	I C
	Coolant/Level	/	Daily	I
	Coolant	150	Annually	R
	Coolant strength	25	3 months	I Inspect strength seasonally
▲	Air Box Sediment Tube	/	Daily	D

	Headlamp Inspection	/	Daily	C apply dielectric grease to connector when replaced
	Tail lamp inspection	/	Daily	C apply dielectric grease to socket when replaced
▲	Air Filter-Main Element	2	Weekly	I C Replace if necessary
▲	Transmission Oil Level	10	Monthly	I change annually
	Battery Terminals	10	Monthly	I C
DL	Brake pad wear	10	Monthly	I
▲	Gear case Oil	10	Monthly	C
		150	annually	R
	Engine Cylinder Head and Cylinder Base Fasteners	25	3 months	I (re-torque required at first service only)
▲	General Lubrication all fittings, pivots, cables, etc.	25	3 months	L
	Engine Oil-Level	/	Daily	I
	Engine Oil Change	30	3 months	R Break-in Service at 1 month. Change oil more often in cold weather use.
▲	Oil Filter	50	6 months	I C
▲	Engine breather hose	100	6 months	I
	Throttle Cable	/	Pre-ride	I
DL	Throttle Cable/Throttle pedal	50	6 months	A L (Grease M) R if necessary
	Shift linkage	50	6 months	I A R if necessary
DL	Transmission belt	50	6 months	I R if necessary

▲	Steering	50	6 months	I L T if necessary
▲	Front Suspension	50	6 months	I L T if necessary
▲	Rear Suspension	50	6 months	I T if necessary
	Spark Plug	100	12 months	I R if necessary
DL	Ignition Timing	100	12 months	I Adjust as needed
DL	Fuel System	100	12 months	Check for leaks at tank, cap, lines, fuel valve, and filter. Replace lines every 2 years.
DL	Fuel Filter	100	12 months	R
	Radiator	100	12 months	I R
	Cooling System hoses	50	6 months	I R if necessary
	Spark arrestor	10	monthly	C R if necessary
DL	Clutches (drive and Driven)	25	3 months	I R R if necessary
	Engine mounts	25	3 months	I T
DL	Valve clearance	100	12 months	I A
DL	Shift selector box (R/N/ H/L)	200	24 months	Change grease every two years
	Exhaust system	100	12 months	I
DL	Brake fluid Level	/	Pre-ride	I
	Brake fluid	200	24 months	Change every two years
	Idle Speed	/	As Required	A
DL	Toe adjustment	/	As Required	Periodic inspection, adjust when parts

				are replaced
	Headlight Aim	/	As Required	Adjust if necessary
▲ DL	Ball joint (A arm- strut)	10	monthly	I, (for damage, wear, and play) R. Replace if necessary

LUBRICANT AND FLUID

	Item	Lube Rec	Method	Frequency
●	1. Engine Oil	SAE15W/40 SG	Add to proper level on dipstick	Check level daily
	2.Brake Fluid	DOT 3 Only	Maintain level,Between fill lines. See "7.CONTROL"	As require; change every two years or 200 hours
	3.Rear Gear case oil	SAE GL-4 85W/90	See "16.MAI-NTENANCE/ Rear Gear Case Lubrication"	Change annually or at 100 hours
	4.Front Gear case oil	SAE GL-4 85W/90	See "16.MAI-NTENANCE/ Front Gear Case Lubrication"	Change annually or at 100 hours
●	5.Steering system	Grease	Lubricate the pivoting and sliding parts	Every 3 months or 50 hours
●	6.Tie rods	Grease	Grease	Semi-annually
●	7.Shift Linkages	Grease	Locate fittings and Grease	Semi-annually
●	8.Front/Rear Wheel bearings	Inspect	Inspect and replace bearings if necessary	Semi-annually
●	9.Ball joints	Grease	Inspect, Locate fittings and Grease, or replace it if necessary	Semi-annually
●	10.Prop Shaft & Shaft Yoke, Spline Joint	Grease	Locate fitting and Grease	Semi-annually
●	11. Front/Rear A-arm pivot Shaft	Grease	Locate fitting on pivot shaft and grease with grease gun	Every 3 months or 50 hours

●	12.Throttle Cable	Grease M	Grease, inspect and replace it if necessary	Monthly or 20 hours
●	13. Accelerator pedal and brake pedal	Grease	Grease, inspect	Monthly or 20 hours

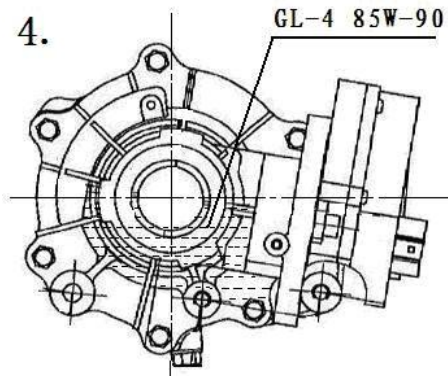
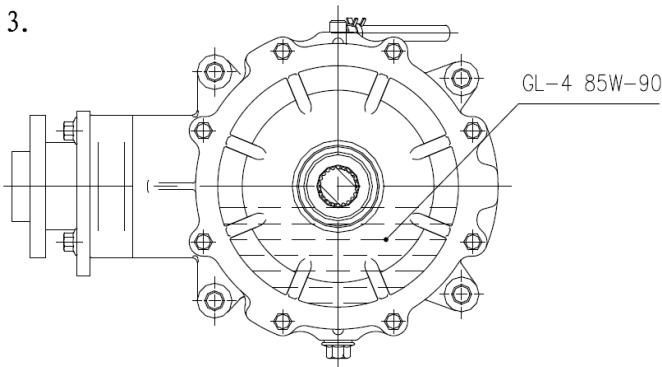
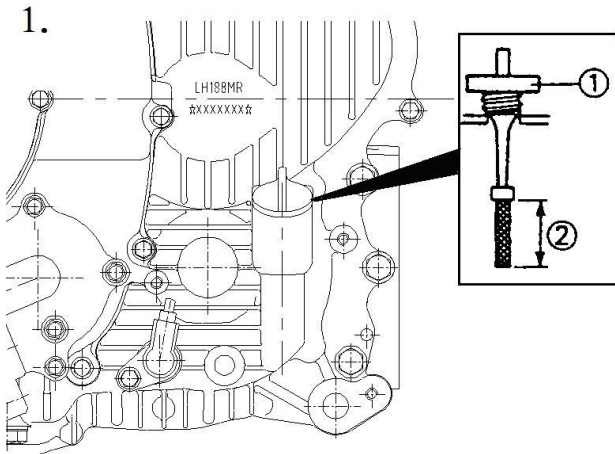

LUBRICATION RECOMMENDATIONS

NOTE:

1. More often under severe use, such as wet or dusty conditions.
2. Grease: Light weight lithium-soap grease.
3. Grease M: Molybdenum disulfide (MoS₂) grease (water resistant).
4. When suspension action becomes stiff or after washing.
5. Hours are based on 10 mph(16Km/h) average.

2.2 THROTTLE PEDAL INSPECTION

THROTTLE FREEPLAY

If the throttle pedal has excessive play due to cable stretch or cable misadjustment, it will cause a delay in throttle speed. Also, the throttle may not open fully. If the throttle pedal has no play, the throttle may be hard to control, and the idle speed may be erratic. Check the throttle pedal play periodically in accordance with the Periodic Maintenance Chart and adjust the play if necessary.

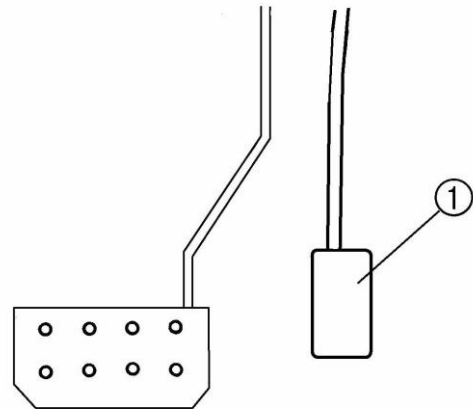

THROTTLE FREEPLAY INSPECTION

1. Apply the parking brake.
2. Put the gear shift lever in the N(Neutral) position.
3. Start the engine, and warm it up thoroughly.
4. Measure the distance the throttle pedal moves before the engine begins to pick up speed. Free play should be 1.5 – 3 mm.

Adjustment

1. Slide the boot off inline cable adjuster sleeve. Loosen adjuster locknut.
2. Turn adjuster until 1.5 to 3 mm, freeplay is achieved pedal. NOTE: While adjusting freeplay, it is important you flip the throttle lever back and forth.
3. Tighten locknut.

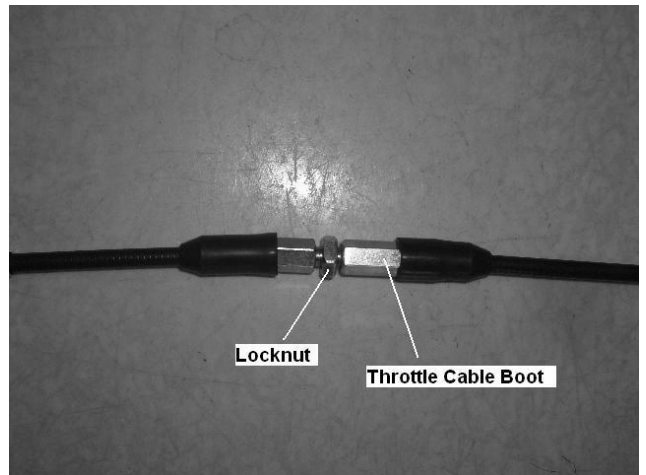

2.3 CHOKE ADJUSTMETN

If the choke knob does not stay out when pulled, adjust the choke tension by tightening (clockwise) the chock cable boot until the choke slider freely but stays out when pulled.

If smooth choke operation is not obtainable, inspect choke cable for kinks or sharp bends in routing

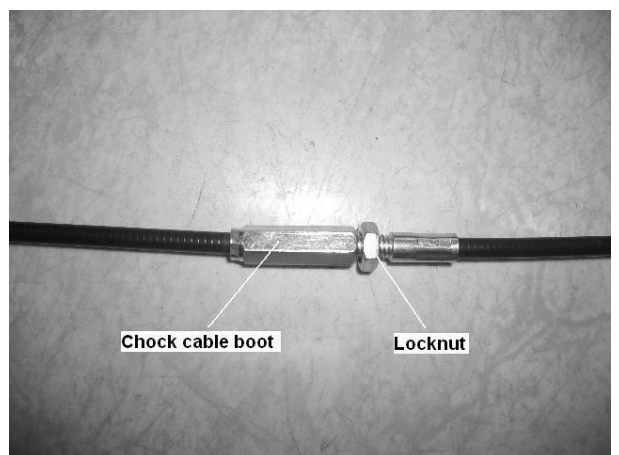

2.4 FUEL SYSTEM

EFI

⚠ WARNING

- ⚠ Always stop the engine and refuel outdoors or in a well ventilated area.
- ⚠ Do not smoke or allow open flames or sparks in or near the area where refueling is performed or where gasoline is stored.
Do not overfill the tank. Do not fill the tank neck.
- ⚠ If you get fuel in your eyes or if you swallow gasoline, see your doctor immediately.
- ⚠ If you spill fuel on your skin or clothing, immediately wash it off with soap and water and change clothing.
- ⚠ Never start the engine or let it run in an enclosed area. Fuel powered engine exhaust fumes are poisonous and can cause loss of consciousness and death in a short time.
- ⚠ Never drain the float bowl when the engine is hot. Severe burns may result.

FUEL LINES

1. Check fuel lines for signs of wear, deterioration, damage or leakage. Replace if necessary.
2. Be sure fuel lines are routed properly and secured with cable ties.

CAUTION:

Make sure lines are not kinked or pinched.
Replace all fuel lines every two years.

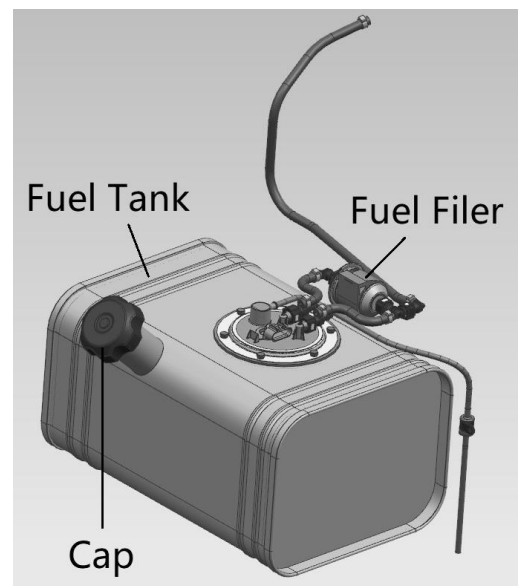

VENT LINES AND ROLL OVER VALVE

1. Check fuel tank, oil tank, battery and transmission vent lines for signs of wear, deterioration, damage or leakage. Replace every two years.
2. Be sure vent lines are routed properly and secured with cable ties.

CAUTION: Make sure lines are not kinked or pinched.

NOTE: Make sure the ↑ mark on the roll over valve is upwards.

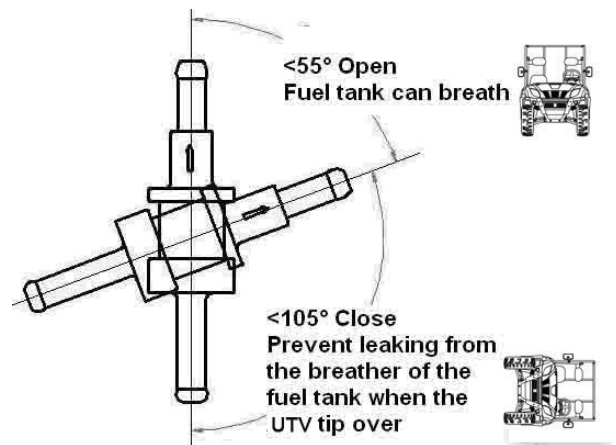

2.5 TOE ALIGNMENT

METHOD: STRAIGHTEDGE OR STRING

Be sure the steering wheel in a straight ahead position.

NOTE: String should just touch side surface of rear tire on each side of the UTV.

Measure from string to rim at front and rear of rim.

Rear rim measurement (A) should be 1/8" to 1/4" (3 to 6 mm) more than front rim measurement (B).

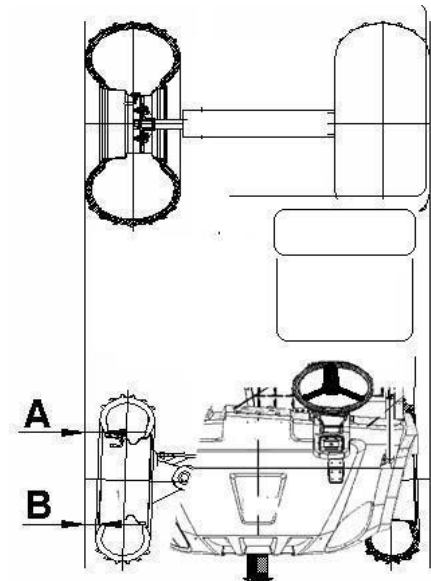

⚠ WARNING

Always pay attention to tie rods assembly, Both ends must screw in same and enough threads length.

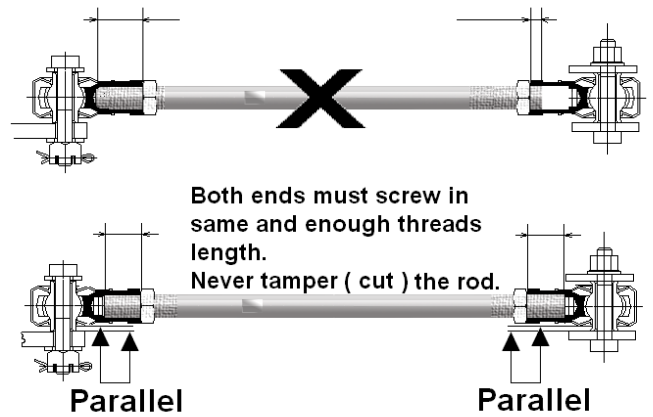

2.6 BRAKING SYSTEM INSPECTION

The following checks are recommended to keep the braking system in good operating condition. Service life of braking system components depends on operating conditions. Inspect brakes in accordance with the maintenance schedule and before each ride

- Keep fluid level in the master cylinder reservoir to the indicated level on reservoir.
- Use DOT 3 brake fluid.

NOTE: Use new brake fluid or brake fluid from a sealed container to avoid contamination to system.

- Check brake system for fluid leaks.
- Check brake for excessive travel or spongy feel.
- Check friction pads for wear, damage and looseness.
- Check surface condition of the disc.

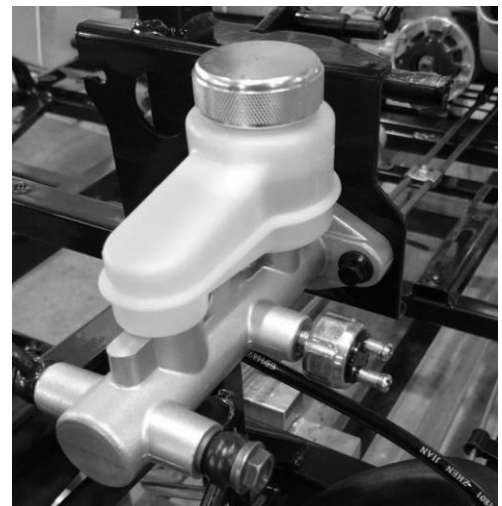

BRAKE PAD INSPECTION

Pads should be changed when friction material is worn to 3/64" (1mm).

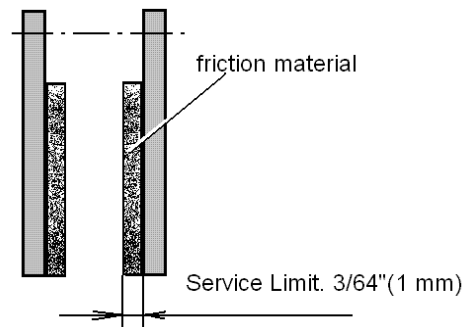

HOSE/FITTING INSPECTION

Check braking system hoses and fittings for cracks, deterioration, abrasion, and leaks. Tighten any loose fittings and replace any worn or damaged parts.

ADJUSTING THE BRAKE PEDAL

Check the brake pedal free play. Free play should be 8 – 12mm. Out of specification → Adjust.

1. Loosen the locknut
2. Turn brake rod in or out until the correct free play is obtained.
 - Turning in: Free play is increased.
 - Turning out: Free play is decreased.
3. Tighten the locknut

ADJUSTING THE PARKING BRAKE

Although the parking brake has been adjusted at the factory, the brake should be checked for proper operation. The mechanical brake must be maintained to be full functional.

1. With the engine off, apply the parking brake lever and attempt to move the UTV.
2. If the rear wheels are locked, it is adjusted properly.
3. If the wheels are not locked, it must be adjusted.

To adjust (set up) the mechanical parking brake, use the following procedure

Note: The adjusting on the caliper is for the wear out of the pads.

1. With the engine off, loosen the adjustor on the lever.
2. Loosen the jam nut of the adjuster on the caliper.
3. Turn the adjuster bolt CW (clockwise) by hand till the pad touch the brake disc, turn the adjuster bolt CCW (counterclockwise) by 1/4 to one turn for 10 to 20mm free play at the end of the parking lever.
4. Tighten the jam nuts securely against the adjusters.
5. Make sure the rear wheels turns freely without dragging.

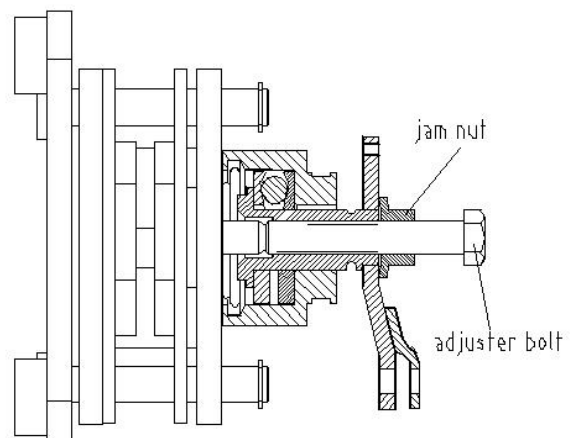
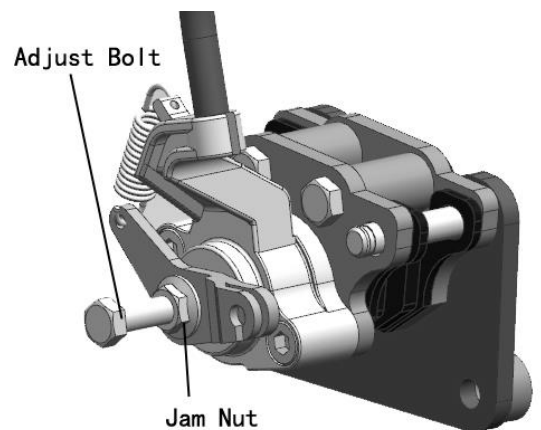

6. Turn the adjuster (the one on the lever) and apply the lever. While adjusting, it is important you apply the lever back and forth for operation, free play and the locking of the parking position.
7. Make sure the rear wheels turns freely without dragging and parking brake works properly.
8. Field test for parking. It must be capable of holding the laden UTV stationary on an 20% up and down gradient.

A temporary adjusting can also be done to the brake cable on the parking lever side by turn the adjuster (nut) directly. But the adjust range is limited. Always do the **procedure 1 to 8** when necessary.

2.7 SUSPENSION SPRING RPELOAD ADJUSTMENT

Operator weight and vehicle loading affect suspension spring preload requirements. Adjust if necessary.

FRONT SUSPENSION

Compress and release front suspension. Damping should be smooth throughout the range of travel. Check all front suspension components for wear or damage.

Inspect shock for leakage

Shock spring preload can be adjusted using the shock spanner wrench.

REAR SUSPENSION

Compress and release rear suspension. Damping should be smooth throughout the range of travel. Check all rear suspension components for wear or damage.

Inspect shock for leakage

Shock spring preload can be adjusted using the shock spanner wrench.

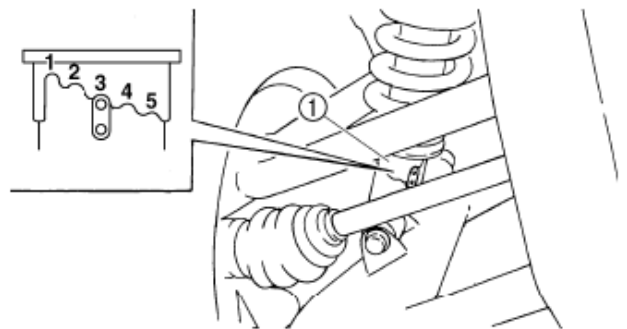

⚠ WARNING

Always adjust both shock absorber spring preload to

the same setting. Uneven adjustment can cause poor handling and loss of stability.

Turn the adjuster ① to increase or decrease the spring preload.

Standard position: 3

Minimum (Soft) position: 1

Maximum (Hard) position: 5

2.8 WHEELS

Inspect all wheels for runout of damage.

Check wheel nuts and ensure they are tight.

Do not over tighten the wheel nuts.

WHEEL REMOVAL

1. Stop the engine, place the transmission in gear and lock the parking brake.
2. Loosen the wheel nuts slightly.
3. Elevate the side of the vehicle by placing a suitable stand under the footrest frame.
4. Remove the wheel nuts and remove the wheel.

WHEEL INSTALLATION

1. With the transmission in gear and the parking Brake locked, place the wheel in the correct Position on the wheel hub. Be sure the valve stem is toward the outside and rotation arrows on the tire point toward rotation.
2. Attach the wheel nuts and finger tighten them. Install as shown at left for front or rear wheels.
3. Lower the vehicle to the ground.
4. Securely tighten the wheel nuts to the proper Torque listed in the table. On wheel nuts, Make sure tapered end of nut goes into taper on wheel.

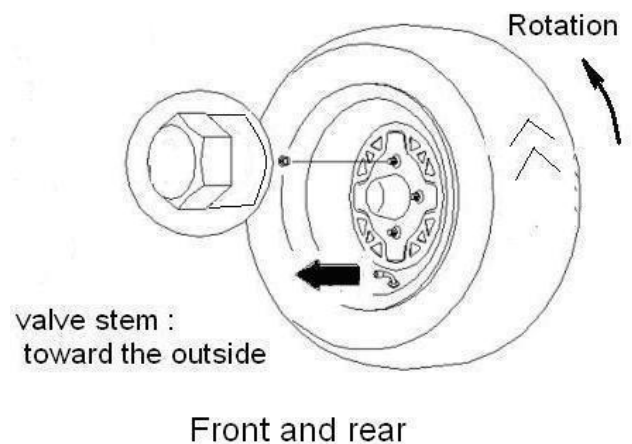

Wheel Nut Torque Specifications

Bolt Size		Specification	
Front	M10X1.25	55Lbs.Ft	75Nm
Rear	M10X1.25	55Lbs.Ft	75Nm

CAUTION: If wheels are improperly installed it could affect Vehicle handling and tire wear.

2.9 TIRE PRESSURE

TIRE INSPECTION

CAUTION:

- Maintain proper tire pressure. Refer to the warning tire pressure decal applied to the vehicle.
- Improper tire inflation may affect UTV maneuverability.
- When replacing a tire always use original equipment size and type and replace in pairs, especially in 4X4 model.
- The use of non- standard size or type tires may affect UTV handling and cause machine damage, especially in 4X4 model.

Tire Pressure Inspection	
Front	Rear
see detail on the mark of sidewall	see detail on the mark of sidewall

TIRE TREAD DEPTH

Always replace tires when tread depth is worn to 1/8" (3mm) or less.

⚠ WARNING

Operating an UTV with worn tires will increase the possibility of the vehicle skidding easily with possible loss of control.

Worn tires can cause an accident.

Always replace tires when the tread depth measures 1/8" (3mm) or less.

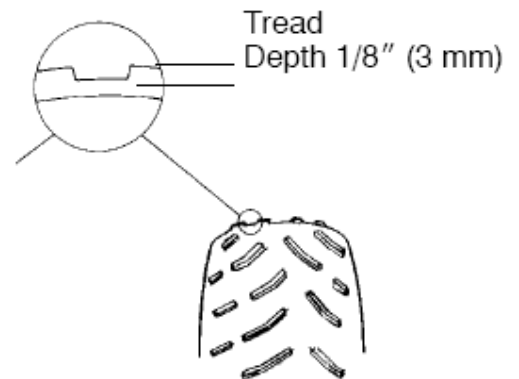

3.0 FRAME , NUTS, BOLTS, FASTENERS

Periodically inspect the tightness of all fasteners in accordance with the maintenance schedule. Check that all cotter pins are in place. Refer to specific fastener torques listed in each chapter.

CHAPTER 3 ENGINE

- 3.1 Removal and Installation of Engine
- 3.2 Engine Overhaul Information
- 3.3 Checks & Adjustment
- 3.4 Engine Removal, Inspection & Installation
- 3.5 Fuel Injection System
- 3.6 Cooling and Lubrication System
- 3.7 Troubleshooting

3.1. Removal and Installation of Engine

Overhaul Info.....3.1.1
 Engine Removal and Installation.....3.1.2

3.1.1 Overhaul info

Operation cautions

●Securely support the UTV with bracket when removing or installing engine.

Take care not to damage frame, engine body, bolts and cables.

●Wrap the frame to avoid any possible damage when removing or installing the engine.

●Following operation doesn't require removal of engine from the vehicle:

- Fuel pump
- Throttle body, air filter
- Cylinder head cover, cylinder head, cylinder body, camshaft
- CVT system, CVT cover
- Right side cover, AC magneto, water pump
- Piston, piston ring, piston pin

●Following operation require removal of engine from vehicle:

- Crankshaft
- Gearbox
- Oil pump

●Tightening torque:

Engine front upper mounting bolt:	50~60N • m
Engine front rear mounting bolt:	50~60N • m
Nut, engine front rear mounting bracket	40~50N • m

●Engine Removal

Remove:

- Plastic
- Cushion Support Component
- Air Filter
- Throttle Body
- Clamp
- Water Inlet Hose

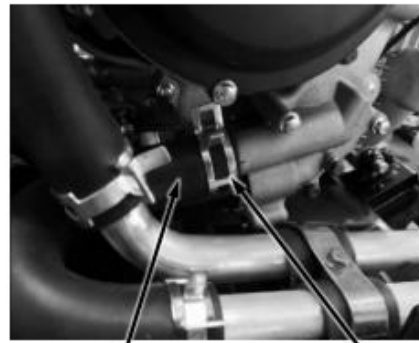

Water Inlet Hose,Engine Clamp

Remove bolt M6X25

Remove shift arm

Remove bolt

Remove shift plate

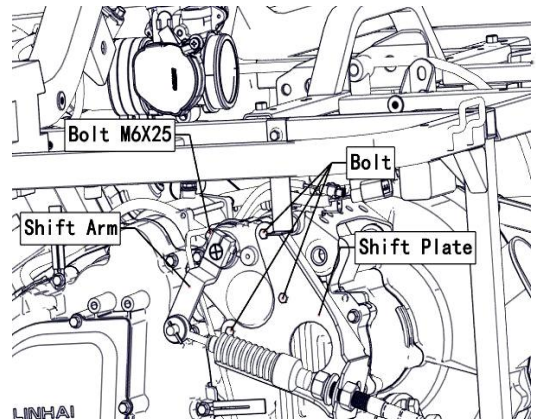

Remove connector of water temperature transducer

Remove clamp

Remove water outlet hose



Water Outlet Hose,Engine Clamp

Remove connectors of magneto, enriching device lead, pickup, water temperature transducer, gear sensor as illustrated on the right.



Connectors

Remove spark plug cap from cylinder.



Spark Plug Cap

Remove protection sleeve of starter relay.

Remove Nut.

Disconnect positive wire of starter relay.



Positive Wire, Starting Motor

Remove Bolt.

Remove negative wire of starter relay.



Negative Wire, Starting Motor

Remove the Bolt and Nut of upper engine hanger.



Bolt and Nut of upper engine hanger

Remove 2 Bolts and Nuts of lower engine hanger



2 Bolts and Nuts of lower engine hanger

Remove 4 Bolts of lower engine hanger.

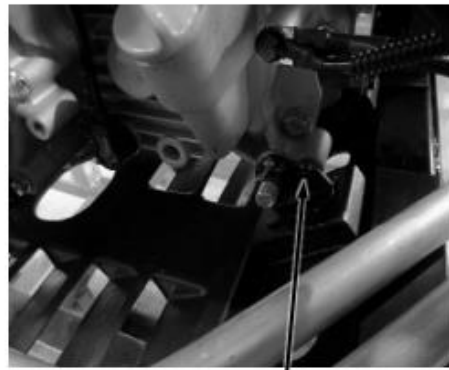

4 Bolts of lower engine hanger

Remove 4 Bolts of front steering knuckle connected with the engine



4 Bolts of front knuckle connected with the engine

Remove 4 Bolts of rear steering knuckle connected with the engine



4 Bolts of rear knuckle connected with the engine

3.1.2 Engine Installation

Put engine onto the frame, install the two lower mounting bolts and nuts.
Then install the upper and lower engine hangers.

Tightening torque: Engine upper hanger bolt:50~60N•m
Engine lower hanger bolt:50~60N•m

Install:

- Water outlet and inlet hoses to engine with proper clamps.
- Positive and negative starting wires to engine.
- Connect all the connectors.
- Spark plug cap.
- Shifting anchor plate and cable shifter to engine.
- Air filter, throttle body and removed parts.

3.2. Engine Overhaul Information

Conversion Table	3.2.1
General Precautions	3.2.2
Fuel, Oil and Coolant	3.2.3
Brake-in Procedures	3.2.4
Engine Exterior and Engine No	3.2.5
Engine Specification	3.2.6
Overhaul Data.....	3.2.7
Tightening Torque Table.....	3.2.8
Tools	3.2.9
Materials for Operation and Fixing	3.2.10
.	

3.2.1 COVNERSSION TABLE

Item	Conversion
Press	1mmHg=133.322Pa=0.133322KPa 1kgf/cm ² =98.0665KPa 1KPa=1000Pa
Torque	1kgf.m=9.80665N.m
Volume	1ml=1cm ³ =1cc 1l=1000 cm ³
Force	1kgf=9.80665N

Warning/Caution/Note

Please read this manual and follow is instructions carefully. To emphasize special information, the symbol and the words WARNING,CAUTION and NOTE have special meanings. Pay attention to the messages highlighted by these signal words.

Warning:

Indicates a potential hazard that could result in injury or death.

Caution:

indicates a potential hazard that could be result in vehicle damage.

Note:

provides key information to make procedures easier or instruction clearer.

Please note, however, that the warnings and cautions contained in this manual can't possibly cover all the potential dangerous information to the servicing, or lack of the vehicle. Except WARNINGS and CAUTIONS stated in this manual, mechanic should have a basic understanding of the mechanical ideas and the procedure of machine repair. If mechanic can't master all the troubleshooting operation, please consult with qualified mechanic for advice.

3.2.2 GENERAL PRECAUTIONS

Warning ! Proper service and repair procedures are important for the safety of operator and the safety and reliability of the vehicle.

When two or more persons work together, keep reminding each other for safety purpose.

When the engine indoors starts, make sure that the exhaust gas is forced outdoors.

If use hazardous or flammable material, please strictly operate according to manufacturer's operation manual. Operate in a well- ventilated place.

Never use gasoline as a cleaning solvent.

Do not touch the engine oil, radiator or muffler with bare hands to avoid scalding before it is cooled.

Check all the lines, and fittings related to the system for leakages, after repairing fuel, cooling, lubricating or exhaust system .

Do not dispose used oil, coolant or defective parts optionally for environmental purpose.

CAUTION:

Use genuine LINHAI parts or their equivalent.

Place and store the disassembled parts separately in order for correct assemble.

Use special tools according to service manual.

Make sure that all parts used in reassembly are clean, lubricated them when specified.

Use the special lubricants, sealants and greases.

Pre-tighten the bolts, nuts and screws, then tighten according to the specified torque, from big to small and from inner side to outer side.

Fix torque screw with torque wrench, clean grease or oil from the screw thread before fixing.

Check the parts after disassembling, clean the parts before measuring.

Check parts for tightness and proper operation, after assembling.

Replace the disassembled washers, o-rings, seals, locknuts, lockwashers, cotter pins, circlips with new ones.

3.2.3 FUEL, OIL AND COOLANT

Fuel

Use unleaded gasoline with octane number over 87.

OIL

Use a premium quality 4-stroke motor oil to ensure longer service life of your vehicle. Use only oils that meet API service classifications SN and that have a viscosity rating of SAE10W/50. If oil with a rating of SAE 10W/50 is not available, select an alternative according to the chart.

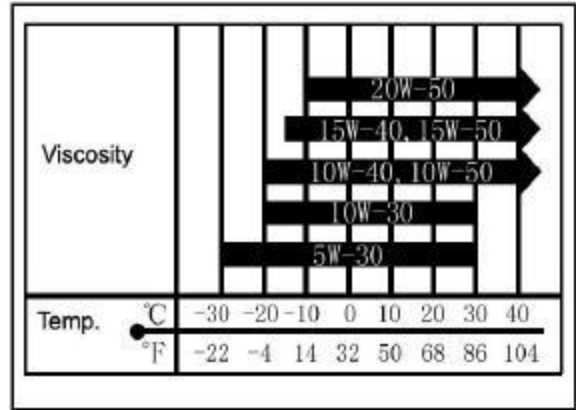

ENGINE COOLANT

Since antifreeze also has corrosion and rust-inhibiting properties, always use coolant containing antifreeze, even if the atmospheric temperature does not go below the freezing point.

It is suggested that the freezing point of antifreeze should be 5°C lower than the lowest ambient temperature where the vehicle is used.

Recommended Coolant: -35°C antifreeze, corrosion-resistant, high boiling point coolant

Warning! Coolant is poisonous. Never drink it. Store it properly.

Caution: DO NOT mix coolant with that of other engines.

3.2.4 BREAK-IN PROCEDURES

During manufacturing only the best possible material are used and all machined parts are finished to a very high standard. It is still necessary to allow the moving parts to “BREAK-IN” before subjecting the engine to maximum stresses. The future performance and reliability of the engine depends on the care and restraint exercised during its early life. Refer to the following break-in engine speed recommendations.

For better performance and durability, a new engine requires a run-in time of 20 hours as under:

0~10 Hours:

Avoid continuous operation above half throttle. Allow a cooling off period of five to ten minutes after every hour of operation. Vary the speed of vehicle from time to time. Do not operate it at one set throttle position.

10~20 Hours

Avoid prolonged operation above 3/4 throttles. Rev the vehicle freely but do not use full throttle at any time.

Note: Keep the daily maintenance during the run-in time and eliminate the troubles, if any. After 20h run-in time, do the maintenance according to the owner’s manual for normal operation of the UTV.

3.2.5 Engine Exterior and Engine No

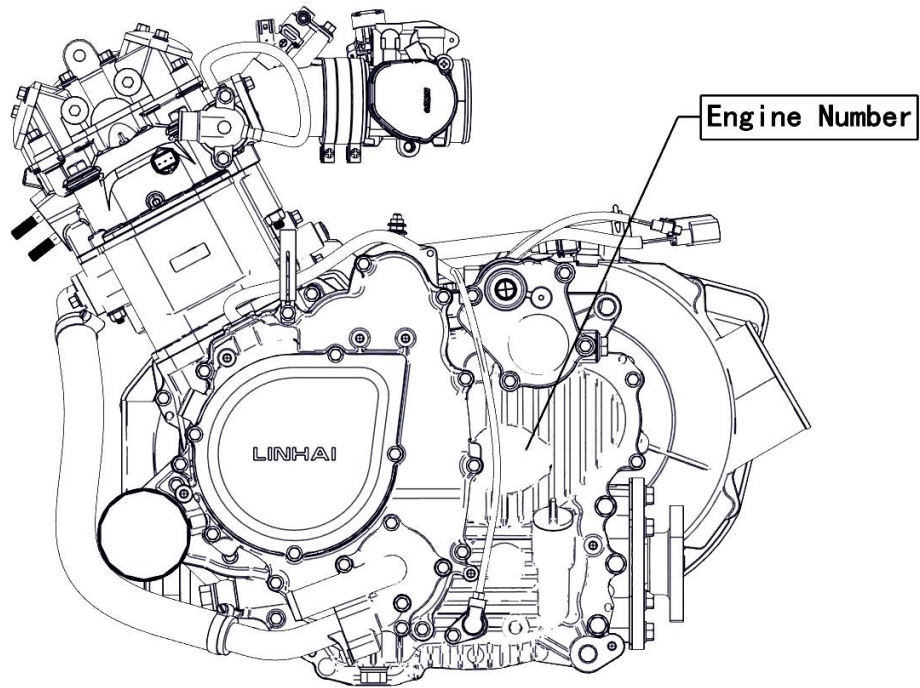

View From Engine Right Side

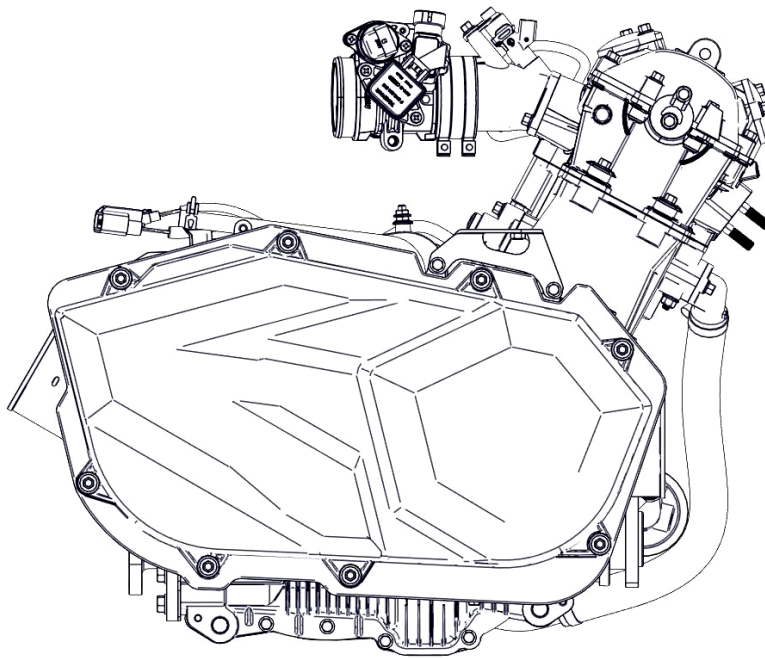

View From Engine Left Side

3.2.6 Engine Specification

REF. NO	ITEM		Type/SPECIFICATION
1	Type		Single Cylinder, 4-Stroke, Liquid-cooled, 4 Valve, SOHC
2	Bore and stroke		87.5mm×82.0mm
3	Displacement		493ml
4	Compression ratio		10.2: 1
5	Lowest continuous idle speed with load		1400r/min±100r/min
6	Starting type		Electrical starting
7	Electrical System	Ignition / Ignition Timing	EFI ECU Magneto ignition/BTDC10°1500r/min
		Spark Plug/ Spark Plug Gap	DPR7EA-9 (NGK)/0.8mm-0.9mm
		Magneto	Permanent Magnet AC Type
8	Combustion System	Combustion Chamber	Triangle Combustion Chamber
		Air Filter	Sponge Element Filter
		Gasoline	RQ-87
9	Valve System	Valve Type	SOHC/Chain Drive
10	Lubrication System	Lubrication Type	Pressure & Splash
		Oil Pump	Trochoid
		Filter Type	Full Flow Filter Screen
		Oil Type	SAE10W-50/SN
11	Cooling System	Cooling Type	Closed Coolant Circulation
		Coolant Type	—35°C Rust-resistant antifreeze
12	Drive System	Clutch type	Wet, Auto-centrifugal
		Operation Mode	Automatic(CVT)+Parking and Gear Shifting
		Gears	2 Forward Gears + 1 Reverse Gear
		Shift Type/Sequence	Hand Operation/L-H-N-R
	(CVT) Gear Ratio	2.919-0.705	
	Transfer Gear Ratio	Final Ratio	1.333(24/18, bevel gear)
		Secondary Ratio	1.952(41/21)
		Gears	Low Gear:2.25(36/16) High Gear :1.35(27/20) Reverse Gear:1.471(25/17)
Total		Low Gear:5.857, High Gear:3.514,Reverse Gear:3.828	
13	Overall Dimension		610×568×519mm
14	Net Weight		70kg
15	Output type		Front and rear shaft output
16	Rotational Direction of Engine Output		Clockwise (from behind engine at forward gear)

3.2.7 Overhaul Data

Item	Standard		Service Limit	Remark
Valve Head Diameter	IN	30.6	-----	
	EX	27.0		
Valve Clearance	IN	0.05-0.10	-----	
	EX	0.010-0.037		
Clearance Between Valve Guide and Valve Stem	IN	0.010-0.037	-----	
	EX	0.030-0.057		
Inner Diameter of Valve Guide	IN & EX	5.000-5.012	-----	
Outer Diameter of Valve Stem	IN	4.975-4.990	-----	
	EX	4.955-4.970	-----	
Valve Stem Play	IN & EX	-----	0.05	
Length of Valve Stem End	IN & EX	2.9-3.1	2.3	
Valve Head Thickness	IN & EX	-----	0.5	
Play of Valve Head Seal	IN & EX	-----	0.03	
Width of Valve Seat Seal	IN & EX	0.9-1.1	-----	
Valve Spring Free Length	IN & EX	40	38.8	
Valve Spring Tension	IN & EX	182-210N,(when compressed to 31.5mm)	-----	
Cam Height	IN	33.430-33.490	33.130	
	EX	33.500-33.560	33.200	
Clearance Between Camshaft Outer Diameter & Hole	Φ22	0.032-0.066	0.150	
	Φ17.5	0.028-0.059	0.150	
Camshaft Outer Diameter	Φ22	21.959-21.980	-----	
	Φ17.5	17.466-17.484	-----	
Inner Diameter of Camshaft Hole	Φ22	22.012-22.025	-----	
	Φ17.5	17.512-17.525	-----	
Camshaft Play			0.10	
Inner Diameter of Rocker Arm	IN & EX	12.000-12.018	-----	
Outer Diameter of Rocker Arm	IN & EX	11.973-11.984	-----	
Cylinder Head Distortion		0.03	0.05	
Cylinder Head Cover Distortion		0.03	0.05	

Cylinder + Piston + Piston Ring + Connecting Rod

Item	Standard			Service Limit	Remark
Cylinder Pressure	1000KPa			-----	
Cylinder-Piston Clearance	0.030-0.051			0.15	
Piston Skirt Diameter	87.460-87.480 (10mm form skirt end)			87.380	
Inner Diameter of Cylinder	87.500-87.522			-----	
Cylinder Joint Face Distortion	0.015			0.05	
Piston Ring Free Gap	Top Ring	R	About 11.7	8.9	
	2ND Ring	R	About 12	9.5	
Piston Ring Gap In Bore	Top Ring		0.15-0.30	0.60	
	2ND Ring		0.15-0.30	0.60	
Piston Ring Groove Clearance	Top Ring		0.04-0.08	0.180	
	2ND Ring		0.03-0.07	0.150	
Piston Ring Thickness	Top Ring		0.97-0.99	-----	
	2ND Ring		1.17-1.19	-----	
Piston Ring Groove Width	Top Ring		1.03-1.05	-----	
	2ND Ring		1.22-1.24	-----	
	Oil Ring		2.51-2.53		
Inner Diameter of Piston Pin Hole	23.002-23.008			23.030	
Outer Diameter of Piston Pin	22.995-23.000			22.980	
Inner Diameter of Connecting Rod Small End	23.006-23.014			23.040	
Clearance of Connecting Rod Big End	0.10-0.55			1.0	
Thickness of Connecting Rod Big End	24.95-25.00				
Crankshaft Play	0.03			0.08	

Lubrication

Item	Standard		Service Limit	Remark
Clearance between Inner and Outer Rotors	0.03mm-0.10mm		0.15mm	
Clearance between Outer Rotor and Oil Pump Body	0.03mm-0.10mm		0.12mm	
Oil Pressure	130Kpa-170Kpa (3000r/min)		-----	
Oil Type	SAE10W-50, SN		-----	
Oil Capacity	When changing	1900ml	-----	
	When Replacing Filter	2000ml	-----	
	Engine Repair	2200ml	-----	

Clutch + Transfer

Item	Standard	Service Limit	Remark
Clutch Engagement Speed	1800-2400r/min	-----	
Drive Belt Width	35	33.5	
Shift Fork to Groove Clearance	0.10-0.40	0.50	
Thickness of Left Shift Fork	5.8-5.9	-----	
Thickness of Right Shift Fork	5.8-5.9	-----	
Shift Fork Groove Width	6.0-6.2	-----	
Drive Output Gear Groove Width	6.0-6.2	-----	

Cooling System

Item	Standard		Service Limit	Remark
Thermostat Valve Opening Temperature	68-74℃		-----	
Thermostat Valve Lift	4.5-6.5mm (at 80℃)		-----	
Radiator Cap Opening Pressure	110-140Kpa		-----	
Corresponding Relation Between Water-temperature Transducer' resistance and water-temperature	Water Temperature (℃)	Resistant of A,C Terminal(Ω)	-----	
	-20	28582±4%		
	50	980±2.2%		
	100	334±2%		
	110	133±2.5%		
Coolant Type	-35℃ antifreeze, corrosion-resistant, high boiling point coolant		-----	

Electrical System

Item		Standard	Remark
Spark Plug	Type	NGK;DPR7EA-9	
	Gap	0.8-0.9	
Spark Character		>8mm	
Ignition coil Resistance	Primary	0.52Ω~0.64Ω	
	Secondary	6.4kΩ~7.8kΩ	
Magneto Coil Resistance	Pick-up	150Ω-300Ω	
Magneto Voltage (Without load)		>50AC),5000r/min	
Max. Magneto Output Power		300W, 5000r/min	
Regulated Voltage		13.5V-15.0V, 5000r/min	
Primary Peak Voltage of Ignition Coil		Peakvoltage ≥3V, 200r/min	
Starter Relay Coil Resistance		3Ω-5Ω	
Auxiliary Starter Relay Coil Resistance		90-100Ω	

3.2.8 Tightening Torques

Item	Quantities	Thread Size (mm)	Tightening Torque (N.m)	Remark
Spark Plug	1	M12×1.25	18	
Water-temperature Sensor	1	M12×1.5	10	Apply Thread Locker
Adjusting Nut, Valve Clearance	4	M5	10	
Nut, Front Drive Shaft	1	M14×1.5	97	
Nut, Drive Bevel Gear	1	M22×1	145	
Nut, Driven Bevel Gear	1	M16×1.5	150	
Limit Nut, Drive Bevel Gear Bearing	1	M60	110	Apply Thread Locker
Nut, Universal Joint Yoke	1	M55	80	Counter Clockwise, Apply Thread Locker
Bolt, Rocker Arm Shaft	2	M14×1.25	40	
Oil Drain Bolt	1	M12×1.5	30	
Bolt, Overriding Clutch	6	M8	26	Apply Thread Locker
Bolt, Magneto Stator	3	M6	10	Apply Thread Locker
Screw, CVT Plate	3	M6	10	Apply Thread Locker
Bolt, Oil Pipe	2	M14×1.5	40	
Bolt, Oil Pump	3	M6	10	
Bolt, Pressure Release Valve	2	M6	10	
Bolt, Drive Bevel Gear Cover	4	M8	32	
Bolt, Driven Bevel Gear Cover	4	M8	25	
Bolt, Gear Limit	1	M14×1.5	18	
Bolt, Splined Spacer	1	M10×1.25	60	
Bolt, drive pulley(CVT drive)	1	M12×1.5-LH	55	
Nut, CVT driven pulley	1	M20×1.5	110	

Tightening Torques

Item	Quantities	Thread Size (mm)	Tightening Torque (N.m)	Remark
Bolt, Crankcase	14	M6	10	
	3	M8	25	
Bolt, Driven Sector Gear	1	M6	12	
Bolt, Oil Filter	1	M20x1.5	36	
Bolt, Oil Starter Motor	2	M6	10	
Bolt, Cylinder Head	4	M10	42	
Bolt, Cylinder Head	2	M6	10	
	1	M8	25	
Bolt, Cylinder (Upper & Lower)	4	M6	10	
Bolt, Cylinder Head Cover	12	M6	10	
Bolt, Chain Tensioner	2	M6	10	
Bolt, Chain Tensioner	1	M8	20	
Bolt, Fan Motor	3	M6	10	
Bolt, Thermostat Housing	2	M6	10	
Bolt, Water Pump Cover	3	M6	10	
Bolt, Water Pump	2	M6	10	
Fixing Bolt, Timing Chain	2	M6	15	Apply Thread Locker
Other Bolts		M5	4.5-6	
		M6	8-12	
		M8	18-25	

3.2.9 Maintenance Tools

Measurement Tools			
No.	Description	Specification	Purpose
1	Vernier Caliper	0-150mm	For measuring the length and thickness
2	Micrometer	0-25mm	For measuring outer diameters of rocker arm, valve stem and camshaft
3	Micrometer	25-50mm	For measuring the max. lift of camshaft
4	Micrometer	75-100mm	For measuring piston skirt
5	Cylinder Gauge		For measuring cylinder bore diameter
6	Small Bore Gauge	10-34mm	For measuring inner gauge of rocker arm, piston pin bore, connecting rod small end bore
7	Dial Indicator	1/100	For measuring the play
8	Straightedge Gauge		Plane measuring
9	Feeler Gauge		Plane and valve clearance measuring
10	Fuel Level Gauge		For measuring the carburetor fuel level
11	Thickness Gauge		For measuring the clearance
12	Spring Balance		For measuring the spring tension
13	Tachometer		For measuring engine speed
14	Oil Pressure Gauge		For measuring oil pressure
15	Compression Gauge & Adapter		For measuring cylinder compression
16	Radiator Cap Tester		For measuring radiator cap opening pressure
17	Ohmmeter		For measuring resistance and voltage
18	Ammeter		For measuring current/switches
19	Thermometer		For measuring liquid temperature
20	Timing Light		For checking the ignition timing
21	Torque Wrench		For measuring the tightening torque
General-purpose and Auxiliary Tools			
22	Alcohol Burner		Heating up
23	Magnetic Stand		For micrometer
24	Slab		Auxiliary tool for measuring
25	V-block		For measuring the play
26	Tweezer		For installation of valve cotter
27	Circlip Pliers		For removal and installation of circlips
28	Long Nose Pliers		For removal and installation of retainers
29	Impact Driver		For removal of cross-headed bolts
30	(-) Driver		
31	(+) Driver		

Special Tools

No.	Description	Specifications	Purpose
1	Spark Plug Wrench		Removal and installation of spark plug
2	Clutch Holder		For removing/installing clutch carrier nuts
3	Oil Filter Wrench		Removal and installation of oil filter cartridge
4	Piston Pin Puller		For removal of piston pin
5	Flywheel Puller		For removal of magneto rotor
6	Crankcase Separating Tool		For separation of left and right crankcase
7	Crankshaft Remover		For removal of crankshaft from left crankcase
8	Crankshaft Installation Set		For installing crankshaft to left crankshaft
9	Valve Spring Compressor		For removal and installation of valve spring
10	Valve Seat Cutter		For valve-seating
11	driving wheel puller		Remove of CVT Drive pulley
12	Bolt M6×70 (all-thread)		Removal/installation of CVT Driven pulley
13	Driven pulley spring compressor		Removal/installation of CVT Driven pulley
14	Couple Gear/Middle Shaft Tool		Removal/installation of the coupling gear nut
15	Bearing Driver	Set	For installation of bearing and oil seal
16	Bearing Removing Tool	Set	For removal of bearing
17	Oil Seal Removing Tool		For removal of oil seal
18	Universal Joint Holder		For removal/installation of the universal joint yoke nut

3.2.10 Materials for Operation and Fixing

Materials for engine operation engine oil, grease and coolant. Fixing materials include sealant, thread locker, etc.

Description	Type	Application Area	Remark
Lubricating Oil/Engine Oil	10W-50 SN	Cylinder bore Crankcase Refer to Engine Lubrication System (→14-14)	capacity 1900ml (for changing oil) 2000ml (for replacing filet) 2200ml (for engine repairing)
Molybdenum lubrication oil		piston pin、 valve stem、 valve oil seal、 camshaft	
Lubricating Grease	#3 MoS ₂ Lithium Base Grease	Oil seal lip, O-ring and sealing faces of other rubber seal materials, bearings with seals, CVT bearing and collar	
Coolant	-35℃ antifreeze, corrosion-resistant, high boiling point coolant	Cooling system、 Water-seal	Capacity according to radiator and water hose system
Joint Face Sealant		Joint face of crankcase, crankcase and cylinder, cylinder head and cover	
Thread Locker		Thread Parts	

3.3. Checks & Adjustment

Periodic Maintenance table	3.3.1
Procedures of Maintenance and Adjustment.....	3.3.2
Valve Clearance.....	3.3.2.1
Engine Idle Speed.....	3.3.2.2
Spark Plug.....	3.3.2.3
Filter.....	3.3.2.4
Fuel Hose.....	3.3.2.5
Drive Belt.....	3.3.2.6
Inspection of Lubrication System.....	3.3.3
Inspection of Cooling System.....	3.3.4
Inspection of Cylinder Pressure.....	3.3.5
Inspection of Oil Pressure.....	3.3.6
Inspection of Clutch Engagement and Lock-up.....	3.3.7

3.3.1 Periodic Maintenance Table

The table below lists the recommended intervals for all the required periodic maintenance work necessary to keep the vehicle at its best performance and economy. Maintenance intervals are expressed in terms of kilometer, miles and hours, whichever occurs first.

Note: More frequent maintenance may be required on vehicles that are used in severe conditions.

Item	Interval	Km	Initial 750	Every 1600	Every 3200	Remark
		Miles	Initial 450	Every 900	Every2000	
		Hours	Initial 20	Every 50	Every 100	
Valve Clearance		I	--	I		IN: 0.05~0.10 EX:0.15~0.20
Idle Speed		I	I	I		1400±100r/Min
Spark Plug		--	--	I		No carbon deposit Gap: 0.8~0.9mm
		Replace every 6000Km				
Air Filter Element		R	R	R		Replace every 1500Km
Fuel Hose		--	--	I		Replace every 4 years
Clutch		--	--	I		
Drive Belt		--	I	R		
Engine Oil		R	--	R		
Oil Filter		R	--	R		
Coolant Level		I	I	I		
Water Hose & Pipes		I	I	I		
Coolant		Replace every 2 years				

I=Inpection and adjust, or replace if necessary

R=Replace

C=Clean

3.3.2 Procedures of Maintenance & Adjustment

This section describes the maintenance procedures for each item mentioned in the Periodic Maintenance Chart.

3.3.2.1 VALVE CLEARANCE

Inspect initially at 20-hour break-in and every 40 hours or every 1000km thereafter. Inspect the clearance after removing cylinder head.

Excessive valve clearance results in valve noise and insufficient valve clearance results in valve damage and reduced power.

Check the valve clearance at the period indicated above and adjust the valve clearance to specification, if necessary.

Remove cover ①

Remove inspection cap ② on left crankcase.

Remove 2 valve adjusting cover ③

Turn the crankshaft until the line④ of T.D.C. on rotor is aligned with mark⑤ of inspection hole on left crankcase.

Insert feeler gauge to check the clearance between the valve stem end and the adjust bolt on the rocker arm.

Valve Clearance (When cold)
IN: 0.05-0.10mm EX: 0.15-0.20mm

Note:
The valve clearance must be adjusted when the engine is cold.
Adjust the valve clearance when the piston is at the Top Dead Center (T.D.C.) on the compression stroke.

If the clearance is incorrect, bring it into the specified range using the special tool.

Loosen valve adjust bolt and nut, insert a feeler gauge between the valve stem end and valve adjusting bolt, tighten valve adjust bolt, make sure it slightly contacts the feeler gauge, tighten bolt and nut.

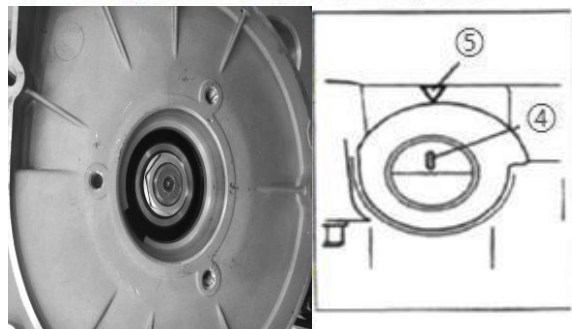
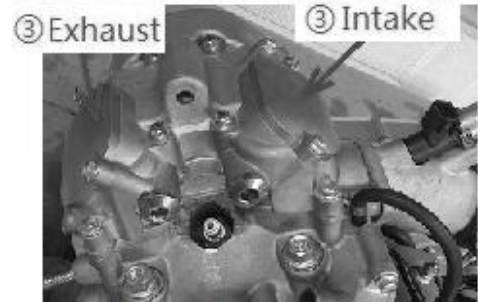

Take out the feeler gauge, measure the clearance.
 If the clearance is incorrect, repeat the above steps until the proper clearance is obtained.

Locknut: 10 N•m

Caution:
Securely tighten the locknut after completing adjustment

Install:
 2 valve adjusting cover;
 Inspection cap;
 Recoil starter;
 Cover plate;
 Apply a small quantity of THREAD LOCKER to recoil starter fixing bolts.

Tools:
 Valve adjuster
 Feeler gauge
Material:
 Thread Locker

3.3.2.2 ENGINE IDLE SPEED

Inspect initially at 20 hours run-in and every 40 hours or 1000km thereafter.

Start the engine and warm it up for several minutes, measure engine speed with a tachometer.

Engine idle speed: 1400r/min±100r/min

Tool: Tachometer

3.3.2.3 SPARK PLUG

Inspect initially at 20 hours run-in and every 80 hours or 2000km thereafter. Replace every 6000km.

Remove the spark plug with a special tool

Specification: DER7EA-9(NGK)

If the electrode is extremely worn or burnt, or spark plug has a broken insulator, damaged thread, etc, replace the spark plug with a new one.

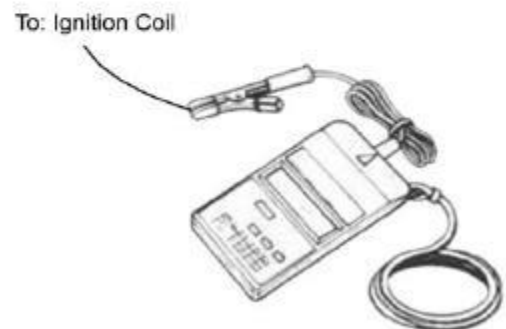

In case of carbon deposit, clean with a proper tool.

SPARK PLUG GAP

Measure the spark plug gap with a feeler gauge.

Out of specification: → Adjust

Spark plug gap: 0.8-0.9mm

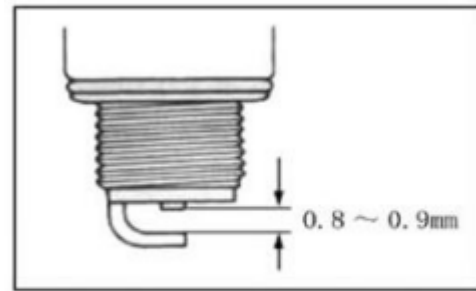

Caution:
Check the thread size and reach when replacing the spark plug. If the reach is too short, carbon will be deposited on the screw portion of the spark plug hole and engine damage may result.

Installation:

Caution:
To avoid damaging the cylinder head threads; first, tighten the spark plug with fingers, and then tighten it to the specified torque using the spark plug wrench.

Tightening Torque: 18 N•m

Tool: Spark Plug Wrench, Feeler Gauge

3.3.2.4 Air Filter

Inspect every 40 hours or 1000 km, clean it if necessary.

If the air cleaner is clogged with dust, intake resistance will be increased, with a resultant decrease in power output and an increase in fuel consumption. Check and clean the air filter as following:

Remove 2 nuts ① and 2 bolts ② fixing clamp③.

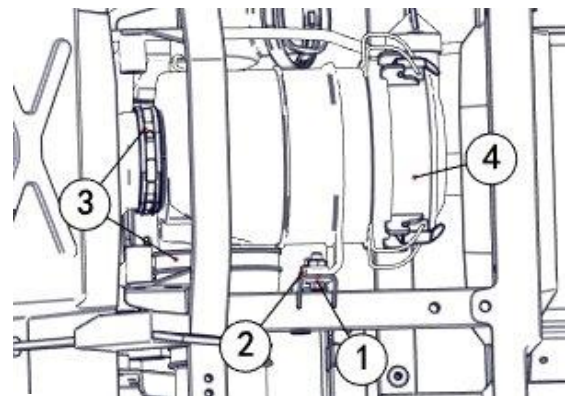

Note:

Be careful not to drop the o-ring into the air filter box that is attached to the air filter top cover.

Loosen bolt ②, clamps ③, remove top cover ④ and separate filter element ⑤

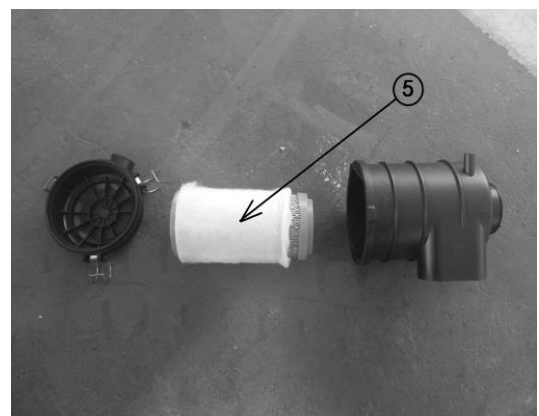

Warning:

Never use with gasoline or low flash point solvents to clean the filter element.

Inspect the filter element for tears. Torn element must be replaced.

Note:

If driving under dusty conditions, clean the air filter element more frequently. The surest way to accelerate engine wear is to operate the engine without the element or with torn element. Make sure that the air filter element is in good condition at all times.

3.3.2.5 Fuel Hose

Inspect every 80 hours or 2000 km, replace every 4 years.

Inspect the fuel hose for damage and fuel leakage. If any damages are found, replace the fuel hose with a new one.

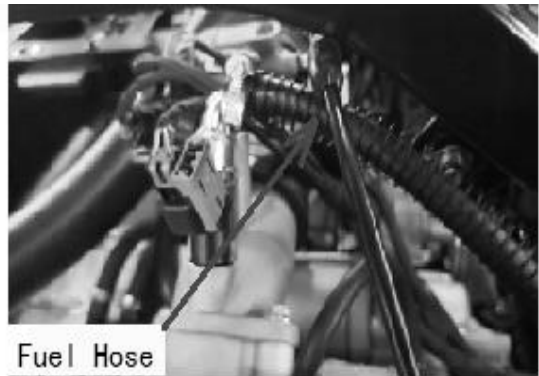

Fuel Hose

3.3.2.6 Drive Belt

Removal:

Remove CVT cover ①

Loosen drive pulley bolt ②(left-hand threads) and washer ③,
use driving wheel puller(left-hand threads) to take drive disk.

Loosen / driven pulley nut ④.

Remove drive pulley ⑤, driven pulley ⑥ together with drive belt ⑦.

Remove drive belt ⑦.

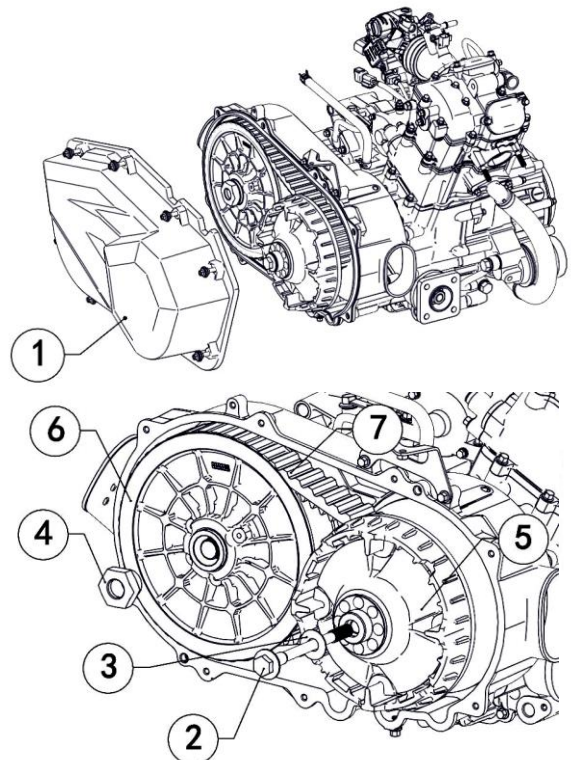

Inspection:

Inspect drive belt for wear and damage. If any cracks or damages are found, replace drive belt with a new one.

Inspect drive belt for width, if width is out of service limit, replace drive belt with a new one.

Service Limit: 33.5mm

Tool: Vernier Caliper

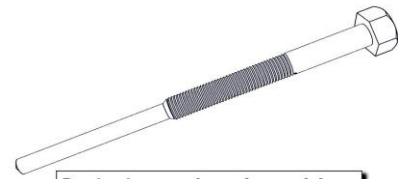

Driving wheel puller

Installation

Reverse the removal procedure for installation.

Pay attention to the following:

Insert drive belt ⑦ as low as possible, between secondary sliding sheave and primary fixed sheave.

Tighten driven pulley nut ④ to the specified torque.

Nut, / driven pulley: 110~120N.m

Install drive pulley ⑤, drive pulley bolt ② (counterclockwise) and washer ③. Tighten the bolt to the specified torque.

Bolt, drive pulley: 55~60N.m

Caution: Fit the drive belt with the arrow on the drive belt points towards normal turning direction.

Screw off Driven pulley Expander, turn driving pulley, until the drive belt is properly seated.

Warning:
The drive belt contact surface of the driven face should be thoroughly cleaned.

Install CVT cover ①.

3.3.3 Inspection of Lubrication System

Replace engine oil and oil filter initially at 20 hours or 200km and every 80 hours or 2000km thereafter.

Check Engine Oil Level

Keep the engine in a plan position.

Remove oil dip rod 1

Clean oil dip rod, insert oil dip rod but do not tighten it.

Take out oil dip rod and check if oil is between upper and lower limit.

If the engine oil is insufficient, fill more oil until the sufficient oil is obtained.

Engine Oil: SAE10W-50SN

Note:
 Keep the engine in a plan position
 Do not tighten oil dip rod when measuring oil level

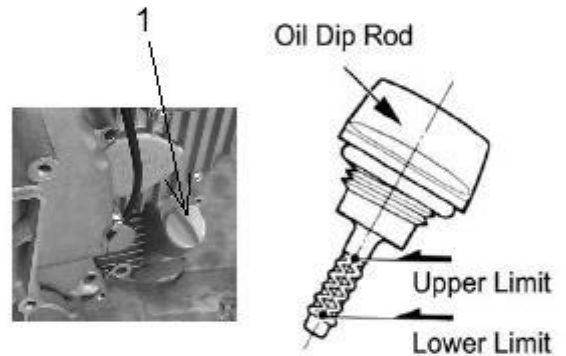

Replacing Engine Oil

Remove oil dip rod 2, drain bolt 2 and washer 3.

Drain out the engine oil while the engine is still warm.

Clean oil dip rod, drain bolt and washer with solvent.

Install washer and drain bolt.

Drain Bolt: 30 N•m

Fill engine oil. (about 1900ml)

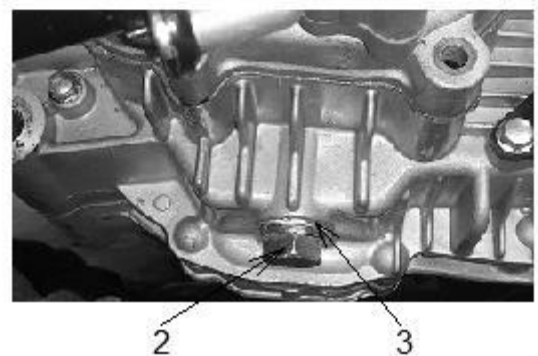

Install oil dip rod, start the engine and allow it to run for several minutes at idling speed.

Turn off the engine and wait for about 3 minutes, and then check the oil level on the dipstick.

Caution:

The engine oil should be changed when the engine is warm. If the oil filter should be replaced, replace engine oil at the same time.

Replacing Oil Filter

Remove relative parts (see Replacing Engine Oil)

Remove oil filter① with the special tool

Install washer and drain bolt

Install new oil filter with the special tool

Fill engine oil (about 2000ml) and check (see Replacing Engine Oil)

Tool: Oil Filter Wrench

Engine Oil Capacity

When replacing oil: 1.9L

When replacing oil filer: 2.0 L

Engine overhaul:2.2 L



3.3.4 Inspection of Cooling System

Check initially at 40 hours or 1000km, replace coolant every 2 years.

Check radiator, reservoir tank and water hoses.

Leakage or Damage: → Replace

Check coolant level by observing the upper and the lower limit on the reservoir tank.

If the level is below lower limit, fill coolant until the level reaches the upper limit.

Replacing Coolant

Remove radiator cap① and reservoir tank cap②.

Place a pan below water pump, and drain coolant by removing drain plug③ and water hose④.

Drain coolant from reservoir tank.

Warning !
 Do not open radiator cap when engine is hot, you may be injured by escaping hot liquid or vapor.
 Engine coolant is harmful. If coolant splashes in your eyes or clothes, thoroughly wash it away with water and consult a doctor. If coolant is swallowed, induce vomiting and get immediate medical attention.
 Keep coolant away from reach of children

Clean radiator with fresh water, if necessary.

Connect water hose④ and tighten drain bolt③ securely.

Fill the specified coolant into the radiator.

Loosen bleed bolt⑤ on water pump, when coolant flow from bleed bolt, tighten the bolt. Install radiator cap ①securely after filling coolant.

Start the engine and keep it running for several minutes. After warm up and cooling down the engine, open radiator cap and check coolant. Fill the specified coolant until the level is between the upper and lower lines on the reservoir tank.

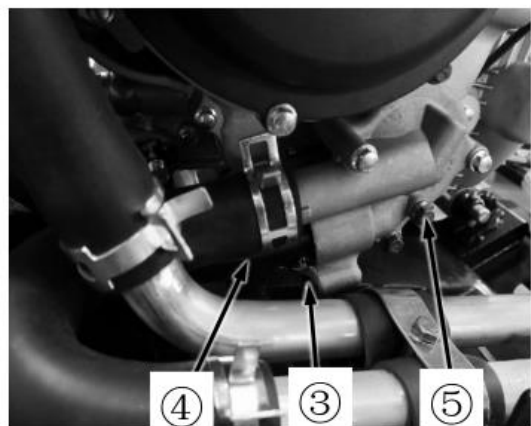
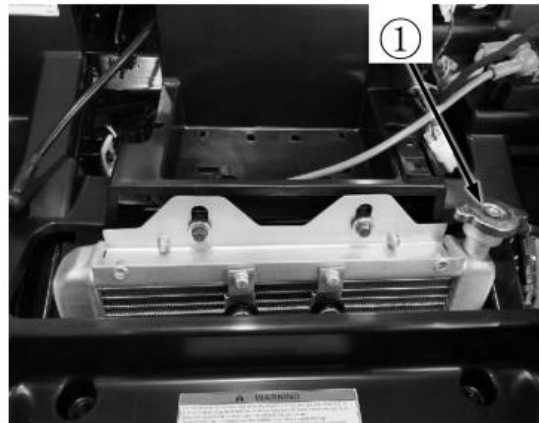

Caution:
 Repeat the above procedures several times and make sure the radiator is filled with coolant and air is discharged.

Fill coolant into the reservoir tank till between upper and lower limit.

Install reservoir tank cap.

Warning: Never mix with other brand

Inspection of Radiator Hose

Perform inspection every 40 hours

Check radiator hose and clamp.

Leakage or Damage: →Replace

3.3.5 Inspection of cylinder pressure

Check cylinder pressure is necessary.

Cylinder Pressure: 1000kpa

A lower cylinder pressure may be caused by:

- Excessive wear of cylinder;
- Wear of piston or piston ring;
- Piston ring jam in groove;
- Poor closure of valve seat;
- Damaged cylinder gasket or other defects

Note: When cylinder pressure too low, check the above items.

Testing Cylinder Pressure

Note: Before testing of cylinder pressure, make sure that cylinder head bolts are tightened to the specified torque and valve clearance has been properly adjusted.

- Warm up the engine before testing;
- Make sure battery is fully charged;
- Remove spark plug 1;
- Install cylinder pressure gauge 2 in spark plug hole and tighten nut;
- Keep throttle full open;
- Press start button crank the engine a few seconds. Record the maximum reading of cylinder pressure.

Tools: Cylinder Pressure Gauge
Adaptor

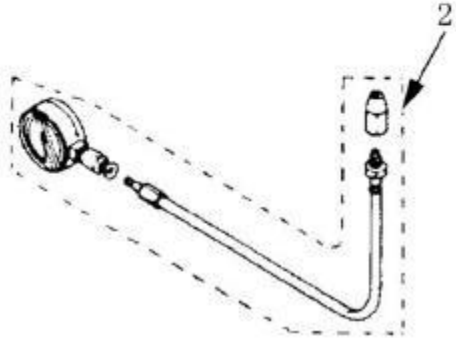
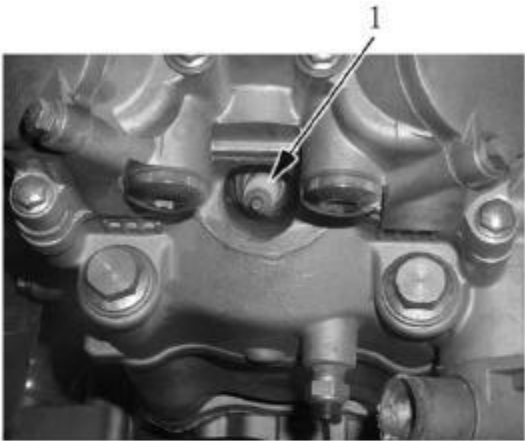

3.3.6 Inspection of Oil Pressure

Oil Pressure: 130~170kpa at 3000r/min

Lower or higher oil pressure may be caused by:

I Oil pressure is too low

- Clogged oil filter;
- Leakage from oil passage;
- Damaged O-ring;
- Oil pump failure;
- Combination of above items;

II Oil pressure is too high

- Oil viscosity is too high;
- Clogged oil passage;
- Combination of above items;

Testing Oil Pressure

- Install hose① and hose②;
- Connect tachometer③with ignition coil
- Install oil pressure gauge④ and joint seat to main oil gallery.

Warm up engine as per following:

Summer: 10 minutes at 2000r/min

Winter: 20 minutes at 2000r/min

After warming up, increase engine speed to 3000r/min, and record readings of oil pressure gauge.

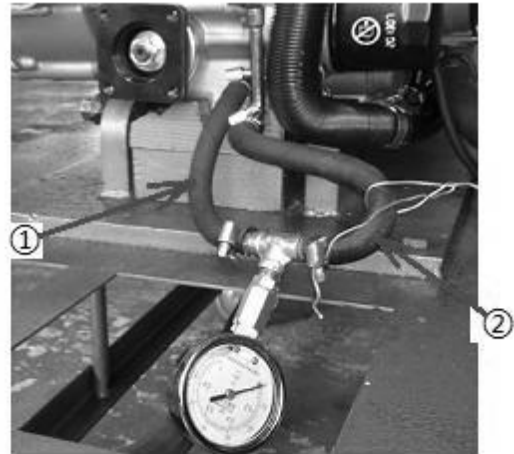

To: Ignition Coil



Tools: Oil pressure gauge
Tachometer

3.3.7 Inspection of Clutch Engagement and Lock-up

Engine is equipped with a centrifugal type automatic clutch.

Before checking the initial engagement and clutch lock-up two inspection checks must be performed to thoroughly check the operation of the drive train.

I Initial Engagement Inspection

- Connect tachometer to ignition coil
- Start engine
- Shift gear lever to "High" position
- Slowly increase throttle and note down the engine speed (r/min) when the vehicle starts to move forward.

Engagement speed: 1800r/min ~ 2400r/min

If the engagement speed is out of the above range, check the following:

- Clutch shoes
- Clutch shoe wheel
- Primary and secondary sheave

Refer to Chapter 12 for inspection of clutch

II Clutch Lock-up Inspection

- Connect the tachometer to ignition coil;
- Start the engine;
- Shift gear lever to "High" position;
- Apply front and rear brakes as firmly as possible;
- Fully open the throttle for a brief period and note the maximum engine speed obtained during the test cycle.

Lock-up Speed: 3300r/min ~ 3900r/min

Warning:

Do not apply full power for more than 5 seconds or damage to clutch or engine may occur.

If the lock-up speed is out of the above range, check the following:

- Clutch shoes
- Clutch wheel
- Primary and secondary sheave

Refer to Chapter 12 for inspection of clutch

Tool: Tachometer

To: Ignition Coil



3.4. Engine Removal, Inspection & Installation
Engine Removal

△ Preparation before engine removal

- Prepare a proper tray used for load of components
- Prepare necessary removal and assembly tools
- Drain up engine oil
- Drain up coolant

△ Engine Periphery
Water Hose/Pipe

- Remove water hose clamp① and②;
- Remove water hose③
- Remove screw④ and water hose⑤

Left Side Cover

- Remove 4 bolts (M6X12) of left side cover
- Remove left side cover

Inspection Plug

- Remove inspection plug⑥ with screwdriver

△ Engine Front Side
Spark Plug

- Remove spark plug⑦ with special wrench
- Tool: Spark Plug Wrench**

- Turn crankshaft, align T.D.C. line A on magneto rotor with mark B of left crankcase

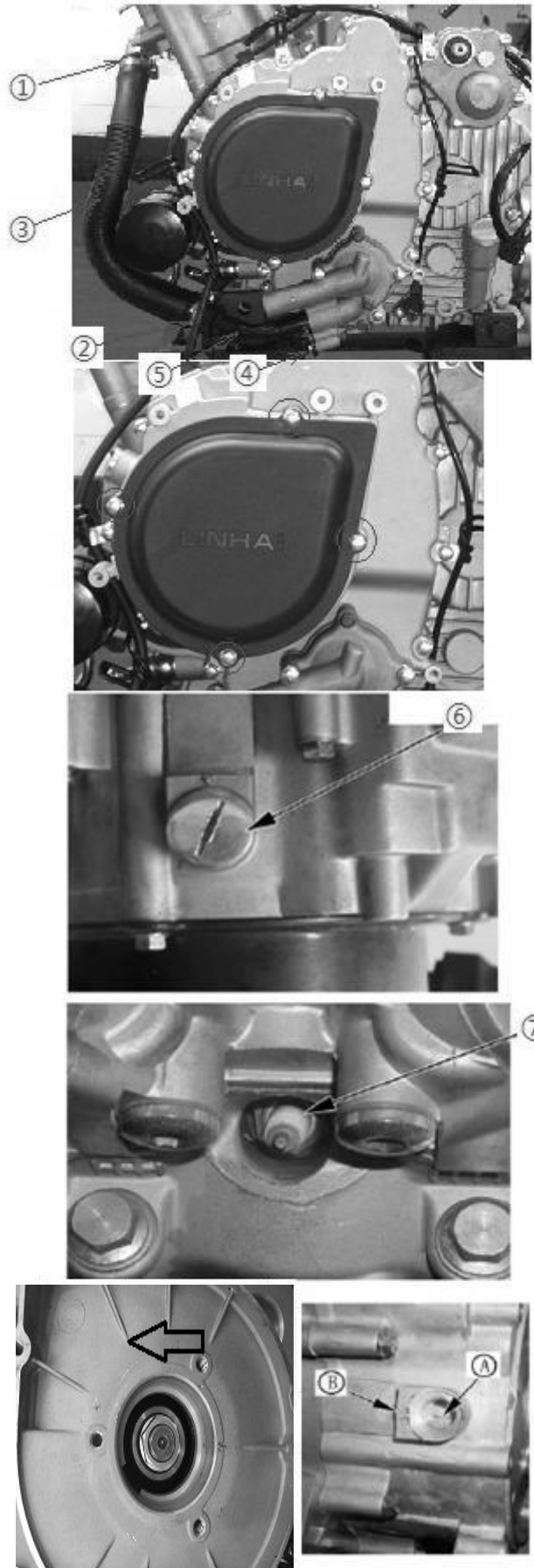

Cylinder Head Cover

Remove valve adjusting cover

Remove 12 bolts of cylinder head cover

Remove cylinder head cover



Timing Chain Tensioner

Remove screw plug ①, insert a flat screwdriver into slot of timing chain tensioner adjuster, turn it clockwise to lock tensioner spring;

Remove tensioner fix bolt

Remove tensioner and gasket

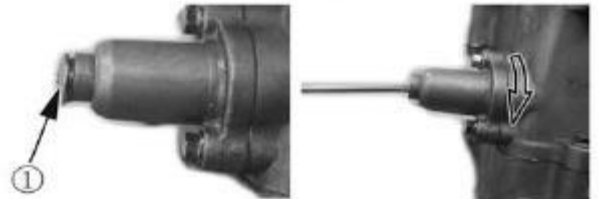

Camshaft

Loosen timing sprocket bolt;

Remove timing sprocket bolt and lock;



Remove C-ring①
Remove timing sprocket from camshaft, remove camshaft

Note: Take care not to drop spacer, bolt, bolt lock and C-ring into crankcase.

Remove tensioner plate

Cylinder Head
Remove cylinder head bolt

Remove cylinder head bolts diagonally;

Remove cylinder head

Note: Take care not to drop dowel pin into crankcase

Cylinder

Remove dowel pin and cylinder head gasket

Remove timing chain guide①

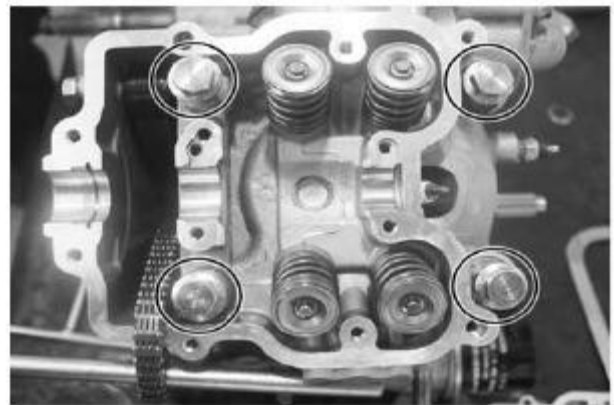
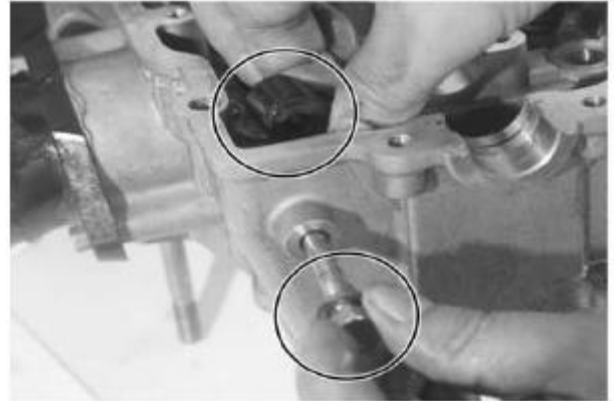

Remove cylinder bolt
Remove cylinder

Note: Take care not to drop dowel pin into crankcase

Remove dowel pin and cylinder gasket

Note: When performing above removal process, be sure to hook up timing chain to prevent it from falling into crankcase

Piston

Remove piston pin circlip① with long nosed pliers

Note: Put a clean rag under piston so as not to drop piston pin circlip into crankcase

Remove piston pin②and piston③

Notes:
When installing piston, make sure its identification conforms to that of cylinder;
When removing piston pin, clean off burrs of piston pin hole and groove. If it's difficult to remove the piston, DO NOT hammer, use a special remover④

Tool: Piston Pin Remover

Δ Engine Left Side

Starting Motor

Remove 2 bolts of starting motor

Remove starting motor

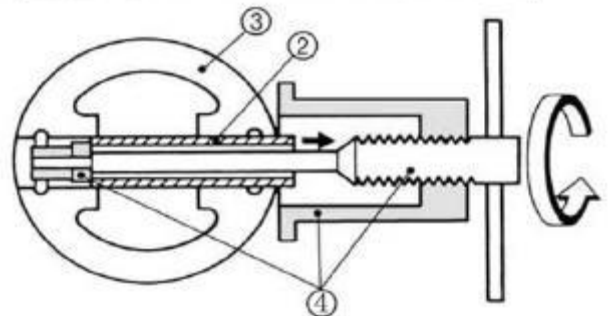
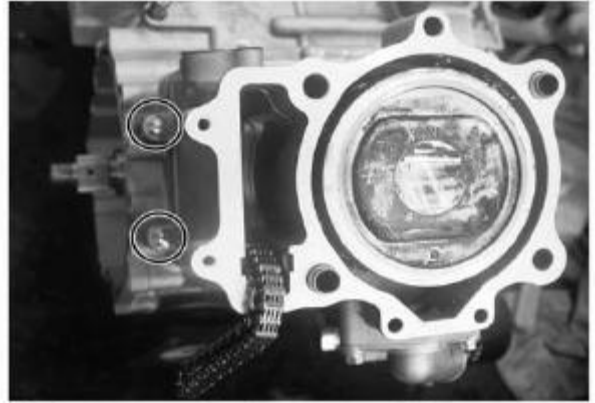

Starting Motor

Oil Filter

Remove oil filter with special tools

Tool: Oil filter Remover



Sector Gear

Remove bolt of sector gear housing cover
Remove wire clip and sector gear housing cover

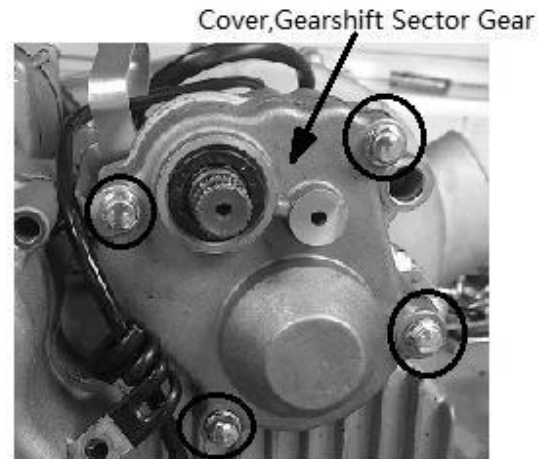

Remove dowel pin and gasket
Remove drive sector gear 1
Remove bolt 2 of driven sector gear



Remove washer 3 and driven sector 4

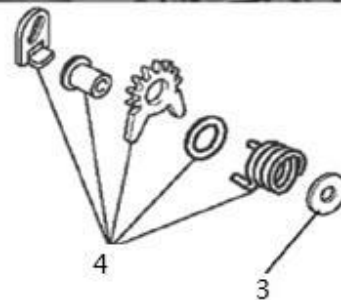

Water Pump

Screw out bolt of water pump
Remove water pump

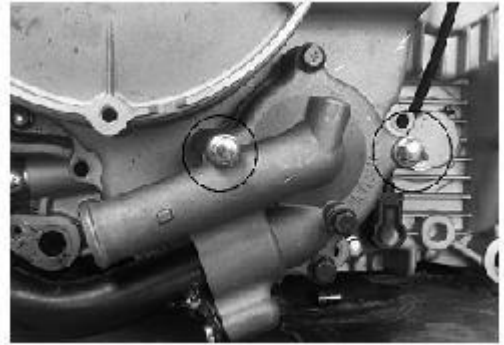

Remove left crankcase cover 1.

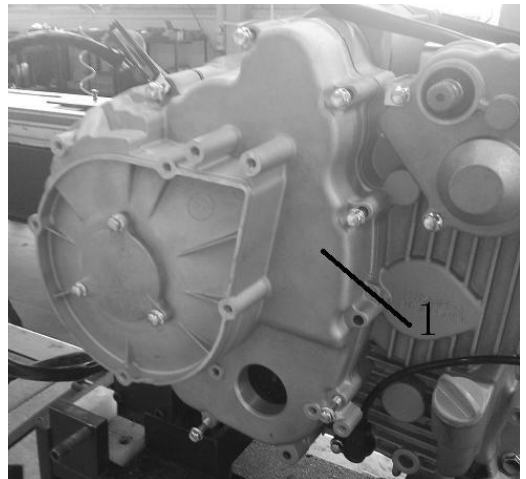

Remove nut.

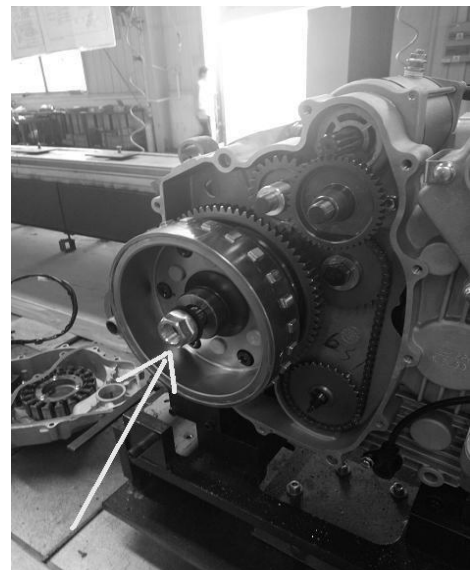

Install special tool to rotor thread;
Remove rotor and woodruff key

Tool: Rotor Remover



Starting Motor Gear

Remove driven gear ① and needle bearing

Remove spacer ②

·Remove dual gear and shaft ③

·Remove idle gear and shaft ④

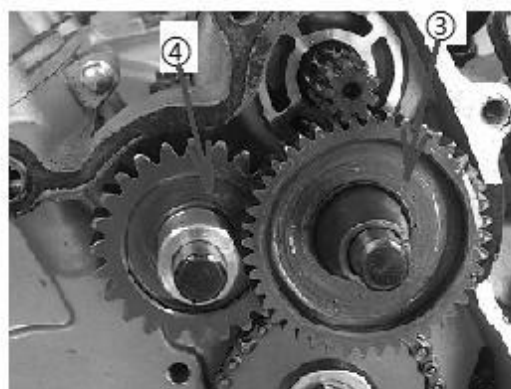
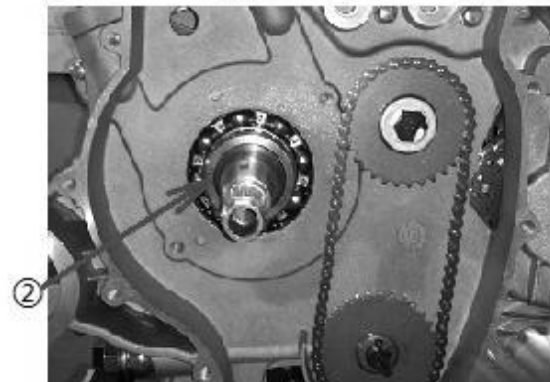

Oil Pump Sprocket and Chain

Remove drive sprocket nut ⑤

Remove C-ring ⑥

Remove oil pump drive and driven sprockets and chain

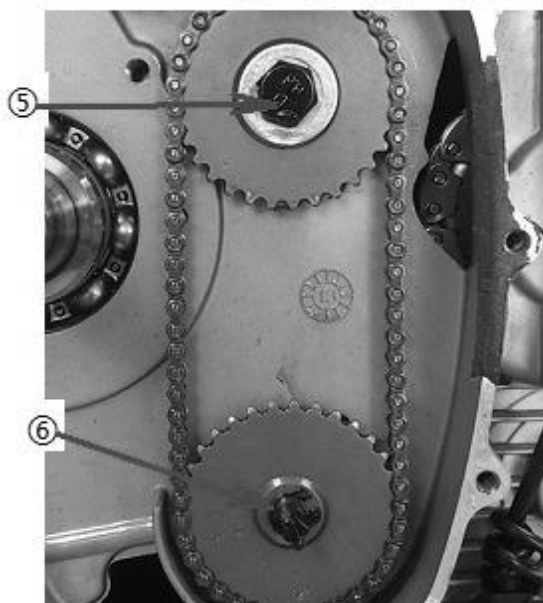

Δ Engine Right Side

CVT Cover

- Remove bolt of CVT cover
- Remove CVT cover
- Remove gasket

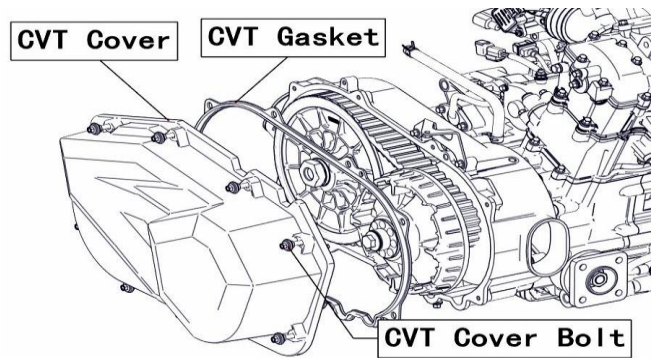

CVT(Continuously Variable Transmission)

- Remove drive pulley bolt (left-hand threads) and Washer. Use driving wheel puller(left-hand threads) to take drive disk

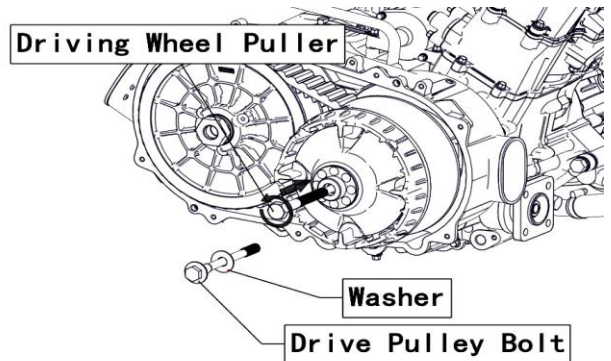

- Remove driven pulley nut

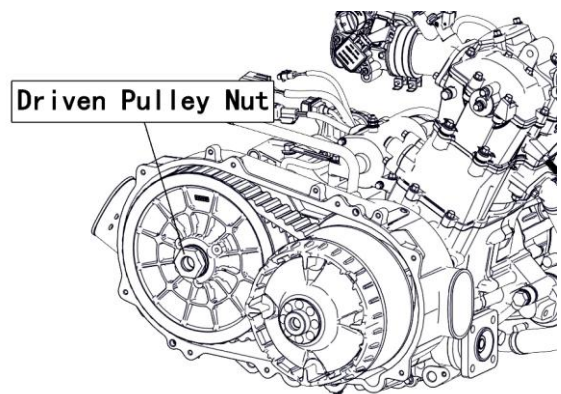

- Remove drive pulley , driven pulley together with drive belt .

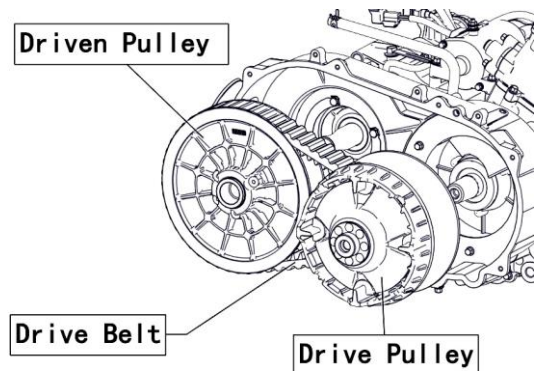

- Remove bolt for air guide plate.

- Remove air guide plate

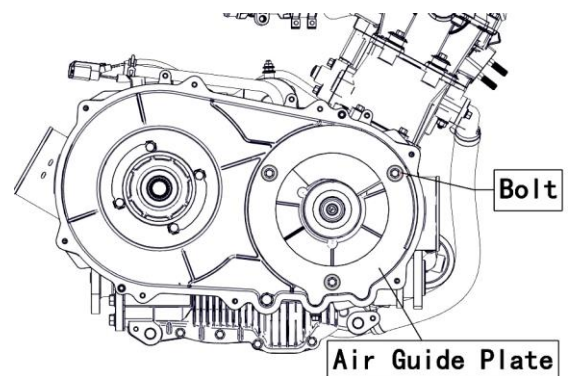

CVT Case

Remove bolt 1 of CVT case

Remove bolt 2 of CVT case

Remove lock plate 1 and lock plate 2

Remove CVT case

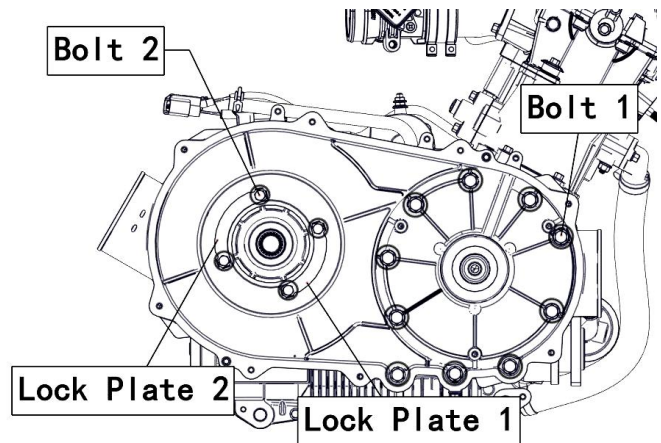

Remove dowel pin, front and rear gasket

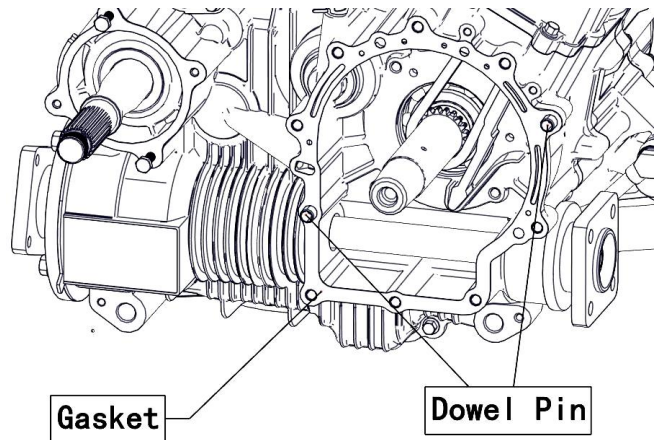

Timing Chain

Remove timing chain

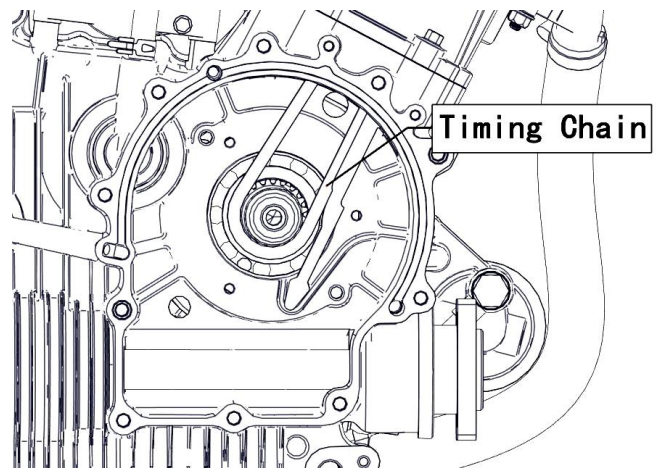

Engine Center

Gear position bolt

- Remove gear position bolt 1
- Remove spring and steel ball



- Right Crankcase
- Remove left crankcase bolts
- Remove right crankcase bolts
- Separate right crankcase with special tool



Caution

The Crankcase separator plate should be parallel with the end face of crankcase
Crankshaft should remain in the left crankcase half.

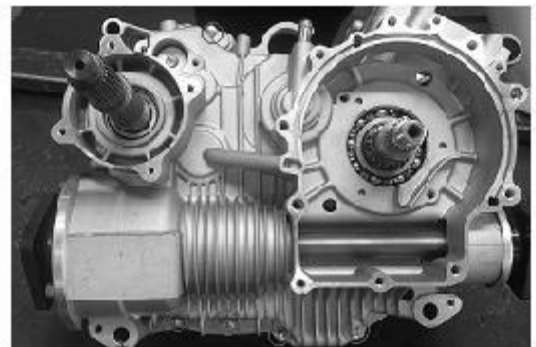

Driven Bevel Gear, Front Output Shaft

- Remove bevel gear cover bolt
- Remove driven bevel gear ②
- Remove front output shaft nut ③



Remove Oil seal①, Bearing limit nut②
Remove Bearing③, Front Output Shaft ④

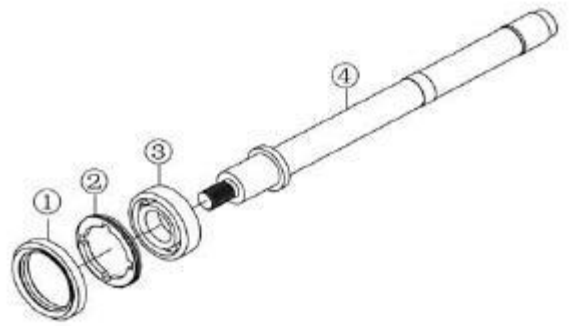

Shift Cam, Fork/Shaft

Remove Shift Cam⑤, Fork /Shaft⑥



Drive Bevel Gear

Remove left crankcase from driven bevel gear



Drive Shaft, Drive Shaft

Remove drive shaft⑦ and driven shaft⑧

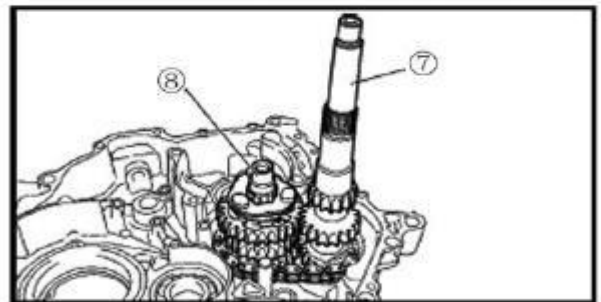

Balancer Shaft

Remove balancer shaft



Balancer Shaft

Crankshaft

Separate crankshaft from left crankcase with special tool

Tool: Crankshaft Separator

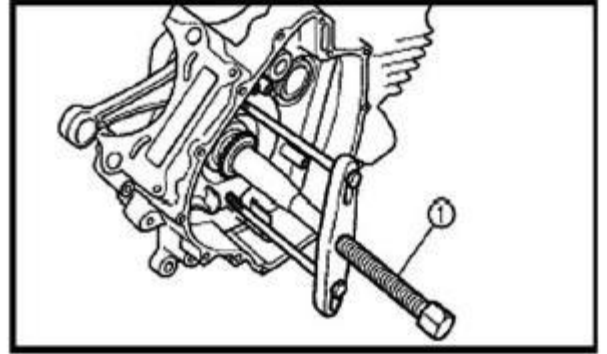

Oil bump, Relief Valve

Remove oil bump and relief valve



Engine Components Inspection

Cylinder Head Cover

Disassembly

Caution: Each removed part should be identified to its location, and the parts should be laid out in groups designated as "Exhaust", "Intake", so that each will be restored to the original location during assembly.

Remove rocker arm shaft bolts A

Remove rocker arm shaft by using M6 bolts B

Cylinder Head Cover Distortion

Clean off sealant from the fitting surface of cylinder head cover, place cylinder head cover on a surface plate and measure distortion with a thickness gauge.

Cylinder head Cover Distortion

Limit: 0.05mm

Tool: Thickness Gauge

Distortion out of range: → Replace

Note: Cylinder head cover and cylinder head should be replaced together.

Rocker Arm Shaft

Measure out diameter of rocker arm shaft with a micrometer.

Rocker Arm Shaft O.D.: (IN, EX)

Limit: 11.973~11.984mm

Tool: Micrometer (0~25mm)

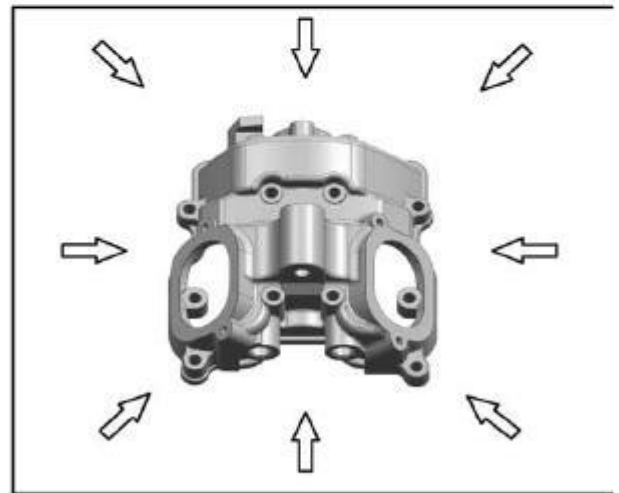
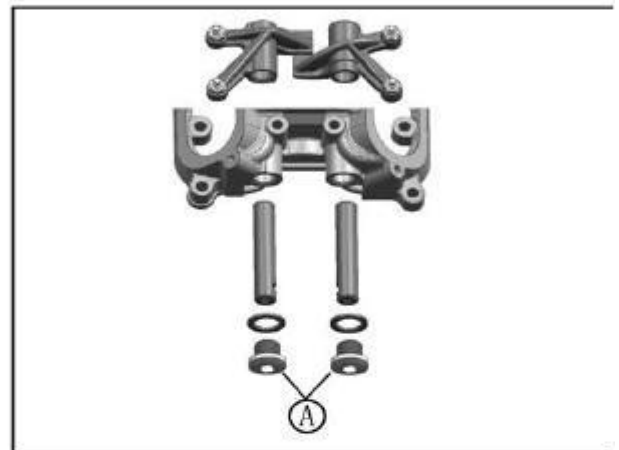
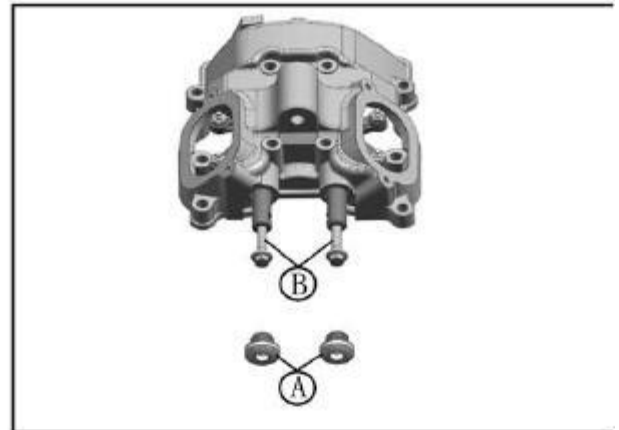

Rocker Arm

When checking the rocker arm, check the inner diameter of the valve rocker arm and wear of the camshaft contact surface.

Rocker Arm I.D. : .000~12.018mm

Tool: Dial Calipers

Assembly

Note: Intake rocker arm shaft A has oil holes.

Apply engine oil to rocker arms and shafts;
Install rocker arms and tighten rocker arm shaft to the specified torque:

Rocker Arm Shaft Bolt: 28N•m

Cylinder Had

Disassembly

Remove intake pipe

Remove water temperature sensor ① and thermostat cover ②

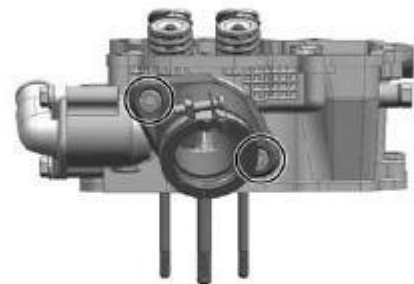
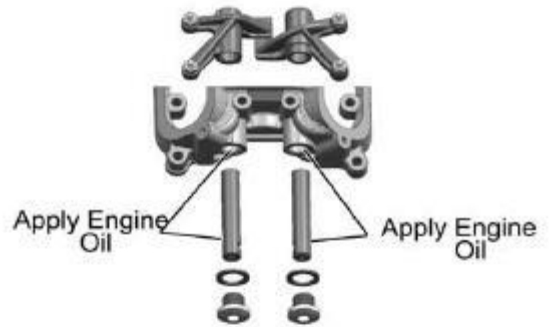
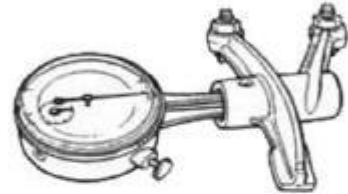
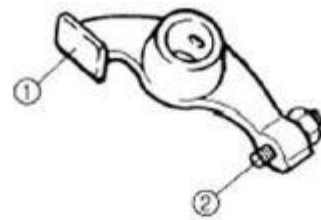

Remove thermostat



Compress the valve spring and remove valve cotter with tweezers.

**Tools: Valve Spring Compressor
Tweezers**

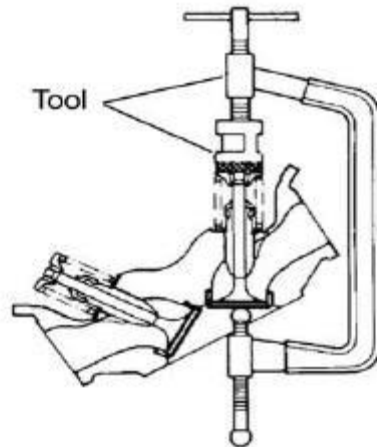

Remove valve spring upper seat and valve spring

Remove valve from the other side.

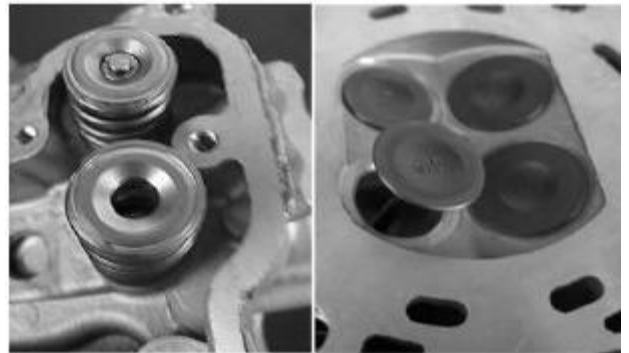

Remove valve stem seal ring and valve lower seat.



Cylinder Head Distortion

Clean off carbon deposit from combustion chamber;
 Check the gasket surface of the cylinder head for distortion with a straightedge and thickness gauge. Take clearance readings from several places. If any clearance reading is out of the service limit, replace with a new cylinder head.

Cylinder Head Distortion Service Limit: 0.05mm

Tool: Thickness Gauge

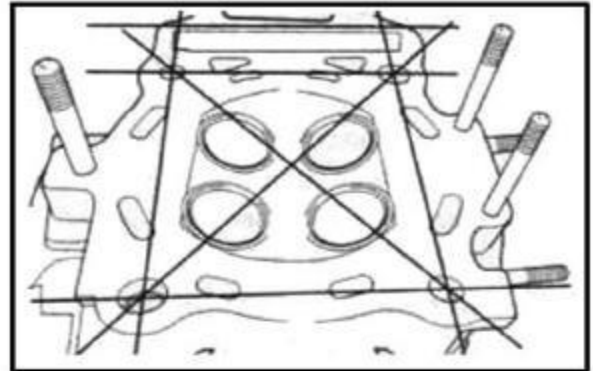

Valve Seat Width

Coat the valve seat with color uniformly. Fit the valve and tap the coated seat with the valve face in a rotating manner. To get a clear impression of the seating contact, use a valve lapper to hold the valve head.

The ring-like dye impression on the valve face should be continuous, without any break. The width of the dye ring, which is the visualized seat width, should be within the following range:

Valve Seat Width: 0.9-1.1mm

Tool: Valve Lapper

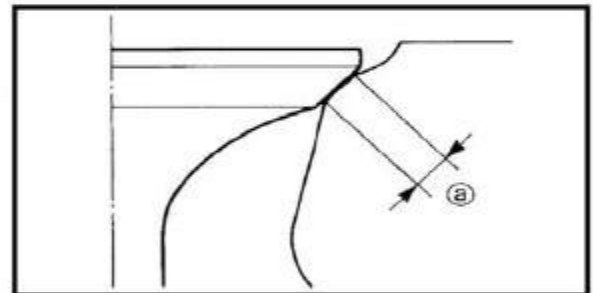
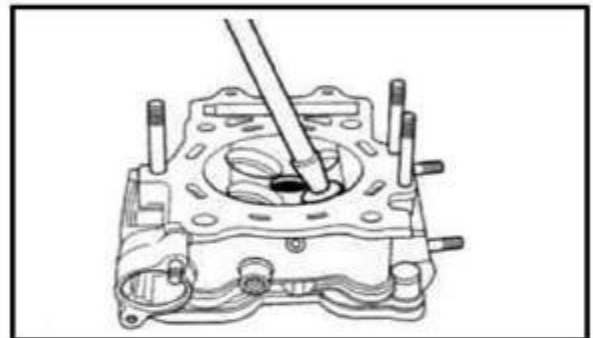

Valve Stem and Valve Guide

Lift the valve about 10mm from valve seat. Check the valve stem deflection in the directions of X and Y perpendicular to each other, with a dial gauge. If the deflection measured is out of the limit, replace either the valve or the valve guide. (If the valve stem is worn to the limit and the clearance is found to be in excess of the limit, replace the valve. If the valve stem is within the limit, replace the valve guide. Double check the clearance after replacing the valve stem or the guide).

Valve Stem Deflection (IN & EX): 0.35mm

Tool: Micrometer

Magnetic Stand

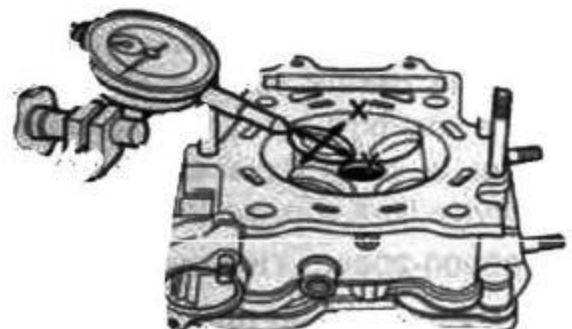
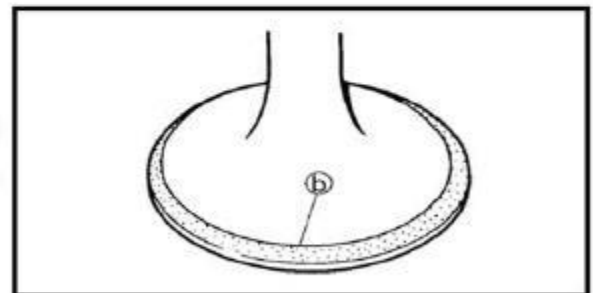

Valve Stem O.D

Measure valve stem O.D with a micrometer

Service Limit

IN: 4.975-4.990mm

EX: 4.955-4.970mm

Tool: Micrometer (0-25mm)



Valve Stem Run-out

Support valve stem with V block as illustrated on the right. Check the run-out with a dial gauge.

Service Limit: 0.05mm

Tool: Magnetism Stand

Dial Gauge (1/100)

V block

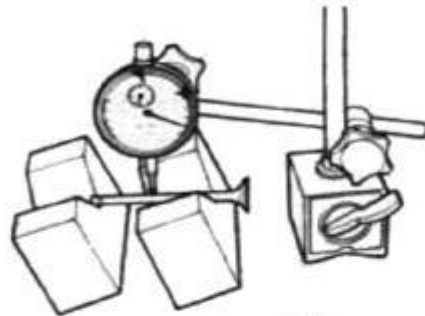

Valve Head Radial Run-out

Measure the valve head radial run-out as illustrated on the right.

Valve head Radial Run-out out of range: →Replace

Service Limit: 0.03mm

Tool: Dial Gauge (1/100)

Magnetic Stand

V Block

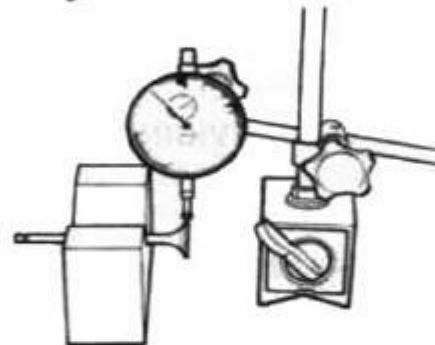

Valve Face Wear

Check each valve face for wear or damage.

Replace valve with a new one if it is found to have abnormal wear. Measure valve head thickness T.

Valve head thickness T out of range: → Replace

Service Limit: 0.5mm

Tool: Vernier Caliper

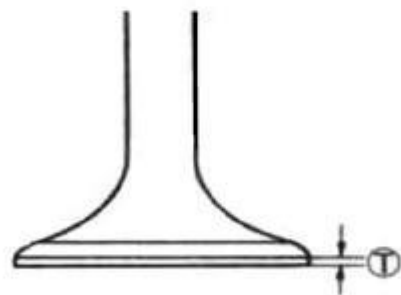

Valve Stem End

Check valve stem end for pitting or wear. In case of any pitting or wear, resurface the valve stem end. If the length T is less than service limit, replace valve with a new one.

Valve Stem End Length

Service Limit: 2.1mm

Tool: Vernier Caliper

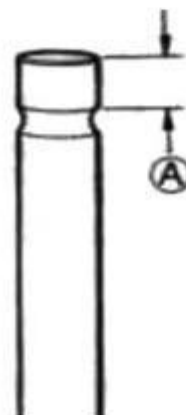

Valve Spring

Valve Spring keeps valve and valve seat tight.
Weakened spring results in reduced engine power output and chattering noise from valve mechanism.

Measure the spring free length.

Spring free length out of range: →Replace

Service Limit: 38.8mm

Tool: Vernier Caliper.

Measure the force to compress the spring to the specified length.

Valve spring tension out of range: → Replace

Service Limit: (IN/EX)

182N-210N/31.5mm

Tool: Spring Scale.

Measure valve spring incline.

Spring incline out of range:→ Replace

Valve Spring Incline Limit: 2.5°/1.7mm

Assembly of Cylinder Head

Install each valve spring seat;

Apply moly oil to valve stem seal and fit into position.

Material: Moly oil

Note: Do not reuse the valve stem seal.

Insert the valves, with stems coated with moly oil all around.

Note: When inserting the valve, be careful not to damage the lip of the stem seal.

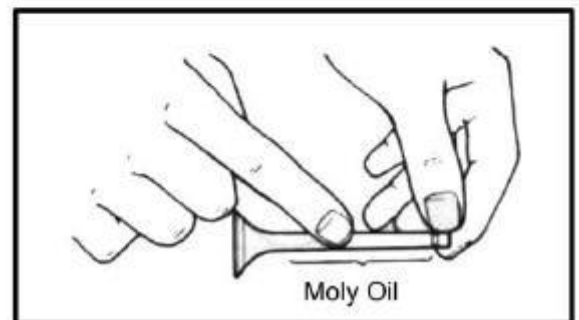
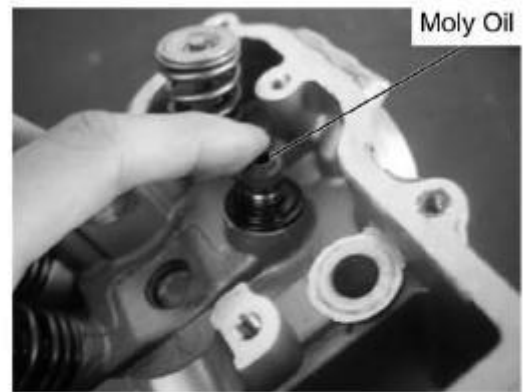
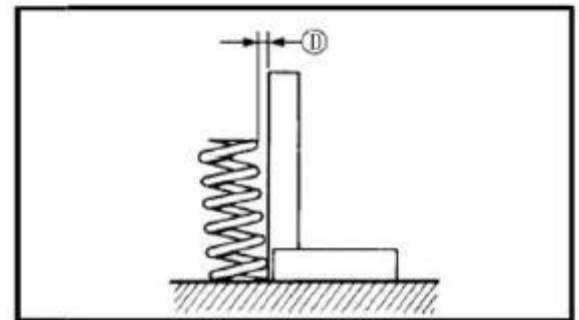
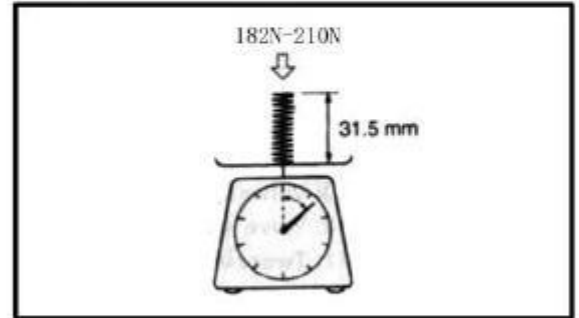
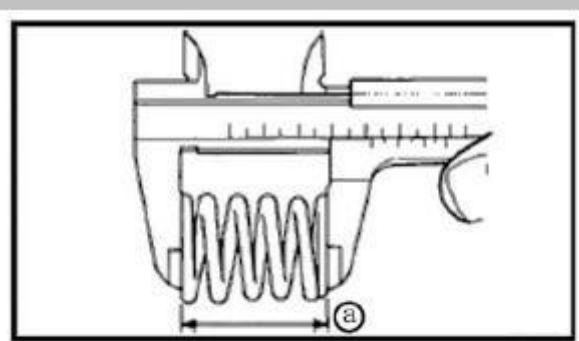

Install valve spring with small-pitch end “b” facing cylinder head. Big-pitch end “a” is marked.

Put on the valve spring retainer. Use the valve spring compressor to press down the spring. Fit the two cotter halves to the stem end and release compressor to allow the cotter ① to wedge in between seat and stem. Make sure that the rounded lip② of the cotter fits into the groove③ in the stem end.

**Tool: Valve Spring Compressor
Tweezers**

NOTE: Knock the valve end with rubber hammer. Make sure valve cotter is fit into groove.

Check the sealing effectiveness of cylinder head. Dip clean solution into valve IN/EX ① and check for any leakage of valve seat ② after a few minutes.

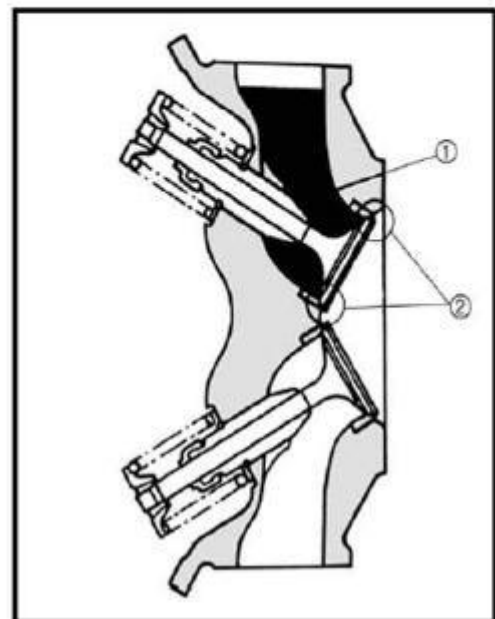
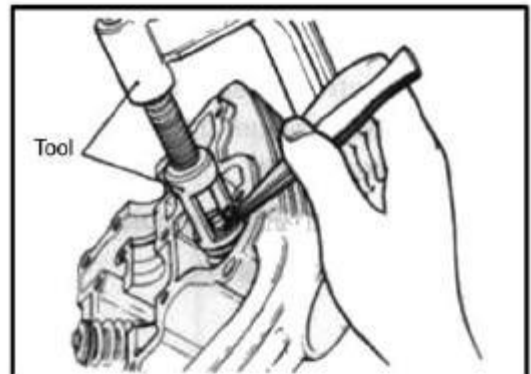
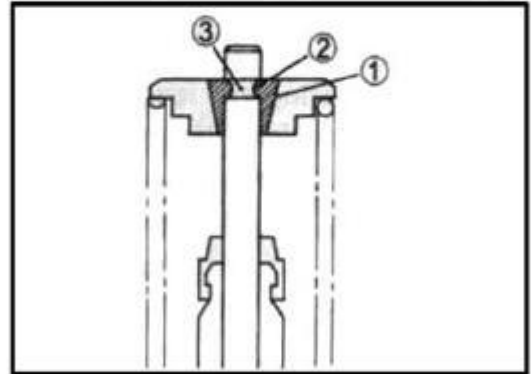
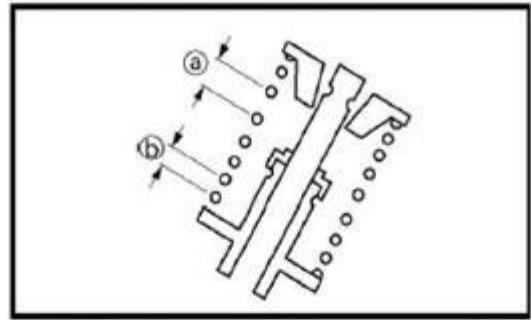

Install thermostat

Install thermostat cover

Install water temperature sensor, apply thread locker to the thread part, tighten it to the specified torque.

Water temperature sensor
Tightening torque: 10 N·m

Install intake pipe, apply lubricant to O-ring.

Camshaft

Check camshaft for wear and run-out of cams and journals if the engines produces abnormal noise or vibration or lacks power output. Any of these symptoms could be caused by wear of camshaft.

Note: Do not try to disassemble the camshaft/automatic decompression assembly. It is not serviceable.

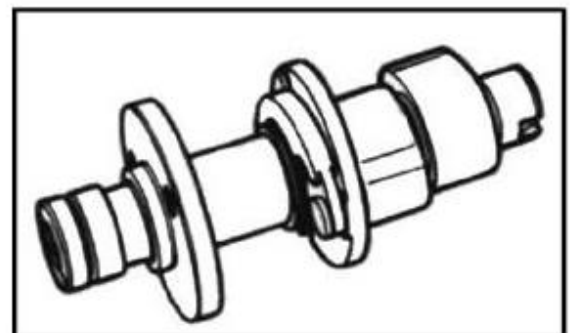
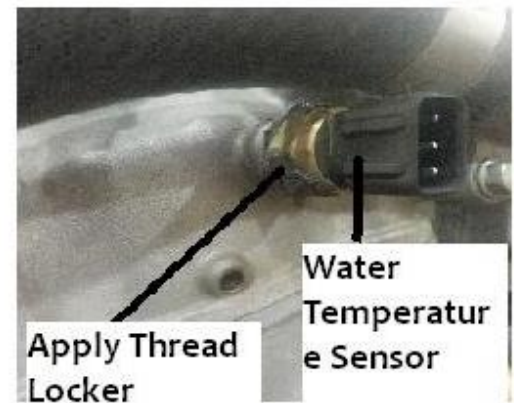

Automatic Decompression

Move the automatic decompression weight with hand and check if it is operating smoothly. If it is not working smoothly, replace with a new camshaft/automatic decompression assembly.

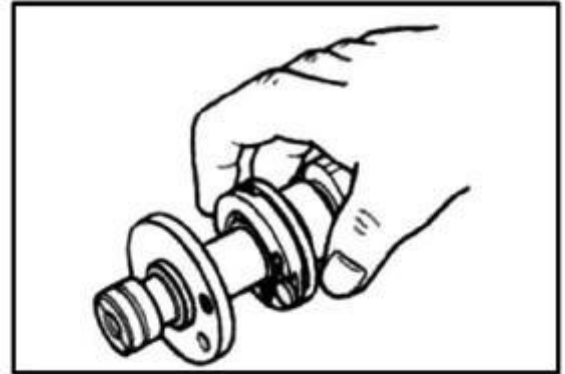

Cam Wear

Worn cams can often cause mistimed valve operation resulting in reduced power output. The limit of cam wear is specified for both IN and EX cams in terms of cam height "a". Measure with a micrometer the cam height.

Cam height out of range: → Replace

Cam height service limit:

IN: 33.130mm

EX: 33.200mm

Tool: micrometer (25-50mm)

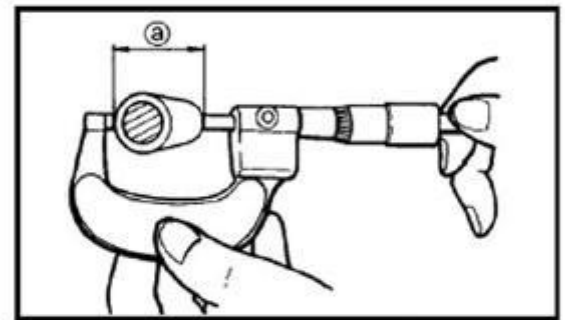

Camshaft Journal Wear

Check whether each journal is worn to the limit by measuring camshaft journal oil clearance with the camshaft installed.

Camshaft journal oil clearance

Service limit: 0.15mm

Check according to the following steps:

Clean off materials from cylinder head and cover;

Install camshaft with plastic gauge;

Install cylinder head cover and tighten bolts evenly and diagonally to the specified torque:

Tightening torque: 10 N·m

Remove cylinder head cover, read the width of the compressed plastic gauge with envelop scale. The reading should be taken from the widest part.

Tool: Plastid Gauge

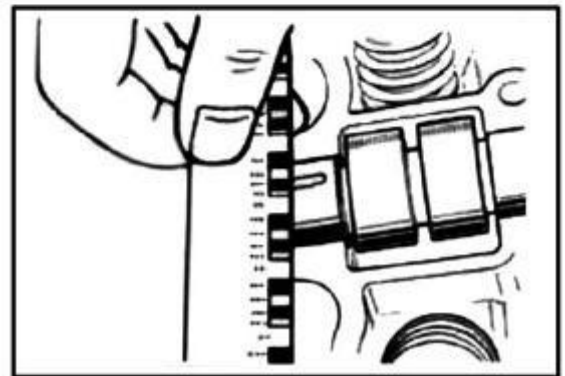

Note: Do not turn the camshaft with plastic gauge in place.

If the camshaft journal oil clearance exceeds the limit, measure the outer diameter of camshaft;

Replace either cylinder head set or the camshaft if the clearance is not correct.

Camshaft Journal O.D.

Measure camshaft journal O.D. with a micrometer.
If the O.D. is out of range, replace camshaft with a new one.

Camshaft journal O.D. service limit:

Sprocket end: 22.959 mm—21.980mm
Other end: 17.466mm—17.484mm

Tool: micrometer (0-25mm)

Camshaft Run-out

Measure the run-out with a micrometer. Replace camshaft if the run-out is out of range.

Service limit: 0.10mm

Timing Sprocket and Chain

Check timing sprocket and chain for wear or damage.
Replace with new parts if abnormal wear or damage is found.

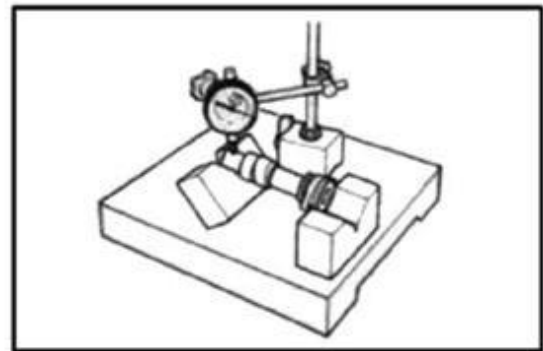
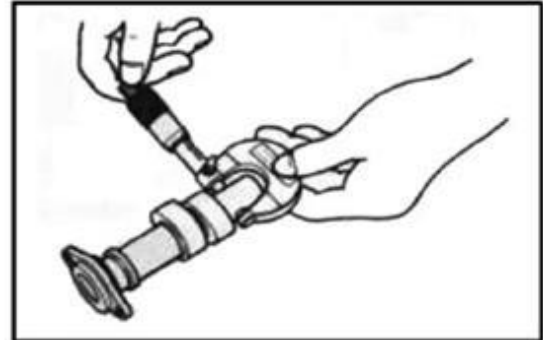

Tensioner and Chain Guide

Check contact surface of tensioner and chain guide for wear and damage.

Replace with new parts if abnormal wear or damage is found.

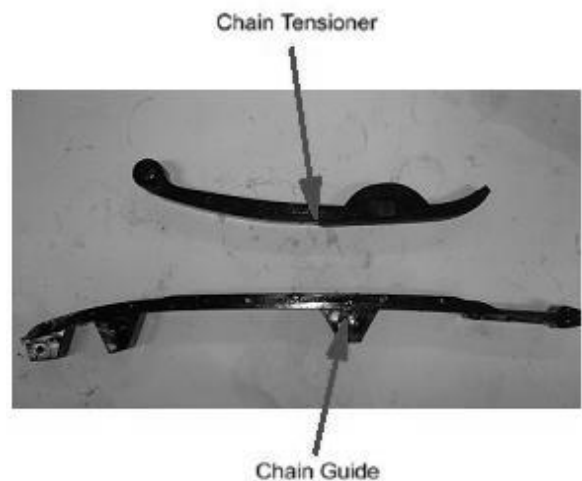

Chain Tensioner Inspection

Check tensioner for any damage or poor function.

Damage, poor function: →Replace

Insert screw driver into the slotted end of adjusting screw, turn it clockwise to loosen the tension and release the screwdriver.

Check the push rod movement. If the push rod is stuck or there is a failure with spring mechanism, replace the chain tensioner with a new one.

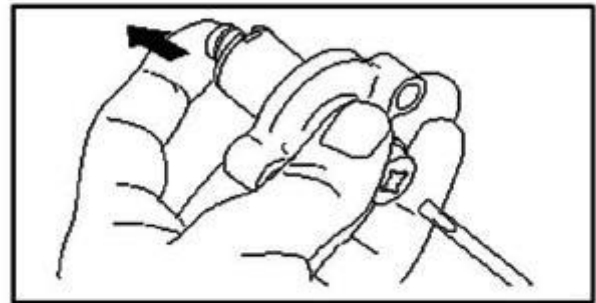
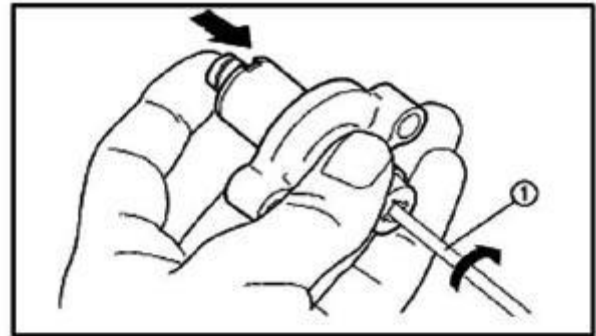

Cylinder Cylinder Distortion

Check the gasket face of cylinder for distortion with a straightedge and thickness gauge and take clearance readings at 7 points as illustrated. If the largest reading at any of the 7 points of the straightedge is out of the range, replace the cylinder.

Cylinder Distortion Service Limit: 0.05mm

**Tool: Straightedge
Thickness Gauge**

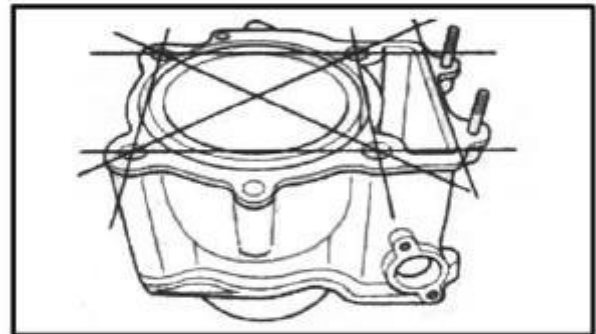

Cylinder Bore

Check cylinder wall for scratches, nicks or other damage. Replace with a new one if any.

Measure cylinder bore diameter at three points of upper, middle and lower.

Standard Cylinder Bore: 87.500-87.522mm

Tool: Cylinder Gauge Set

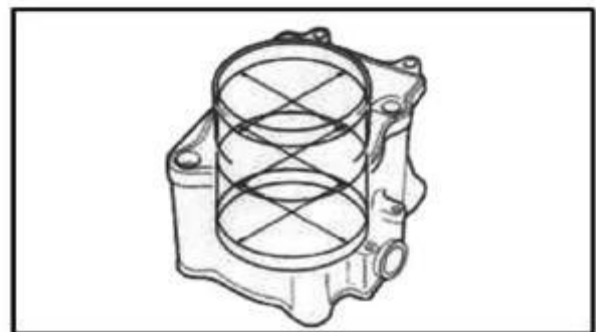
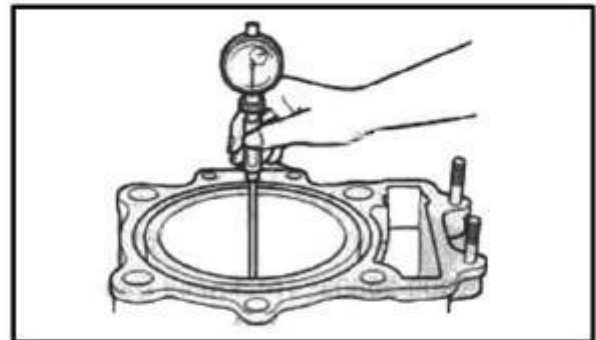

Piston

Piston Diameter

Use a micrometer to measure the diameter at the point 10mm above the piston end, as illustrated on the right. If the measurement is less than the limit, replace the piston

Standard: 87.460-87.480mm

Limit: 87.380mm

Tool: Micrometer (75-100mm)

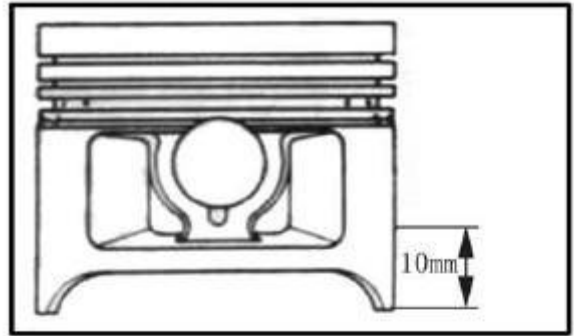

Calculate the piston to cylinder clearance according to the above measurement.

If the clearance is more than 0.15mm, replace the cylinder or piston, or both.

Piston Ring to Groove Clearance

Use a thickness gauge to measure the side clearance of top ring and 2nd ring.

If the clearance exceeds the limit, replace both piston and piston rings.

Service Limit:

Top ring: 0.18mm

2nd ring: 0.15mm

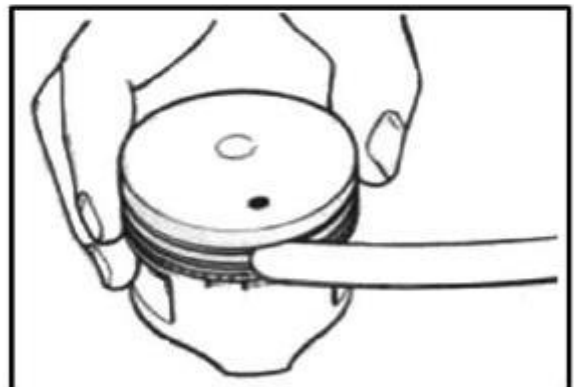
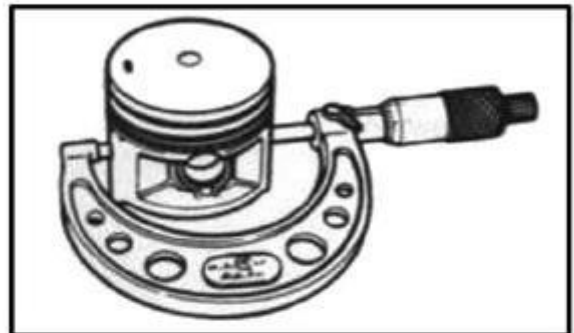

Standard width of piston ring groove

Top ring: 1.03-1.05mm

2nd ring: 1.22-1.24mm

Oil ring: 2.51-2.53mm

Standard thickness of piston ring

Top ring: 0.970-0.990mm

2nd ring: 1.170-1.190mm

Tools: Thickness gauge

Micrometer (0-25mm)

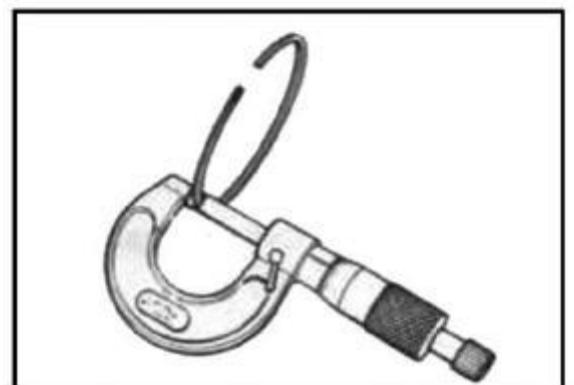

Piston Ring Free End Gap and End Gap

Before installing piston rings, use vernier caliper to measure the free end gap of each ring, and then fit ring into the cylinder.

Use thickness gauge to measure each ring end gap, if any ring has an excess end gap, replace the piston ring.

Piston ring free end gap limit:

Top ring: 8.9mm

2nd ring: 9.5mm

Piston ring end gap limit:

Top Ring: 0.60mm

2nd ring: 0.60mm

Tool: Vernier caliper

Thickness gauge

Piston Pin and Pin Bore

Use a bore gauge to measure the inner diameter of piston pin bore.

Use micrometer to measure outer diameter of piston pin.

If out of limit, replace both piston and piston pin.

Piston pin bore limit: 23.030mm

Use micrometer to measure piston pin outer diameter at three points

Piston pin outer diameter limit: 22.980mm

Tools: Bore gauge (18-35mm)

Micrometer (0-25mm)

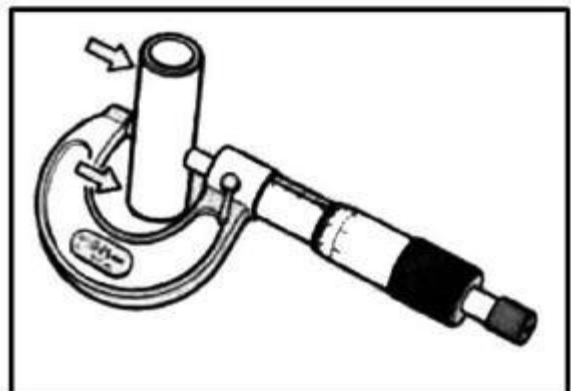
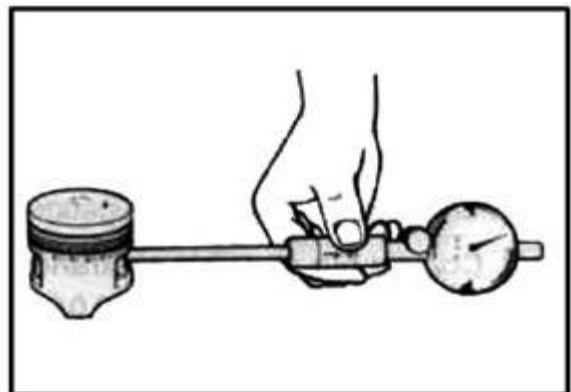
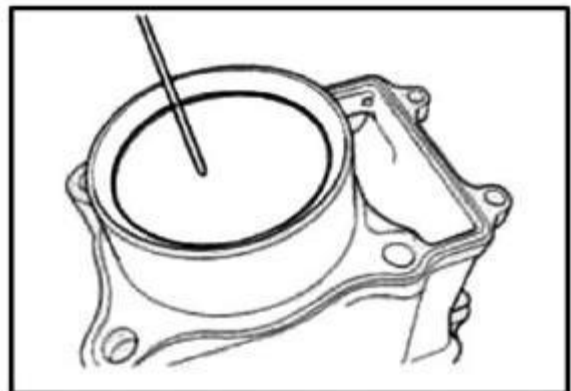

Connecting Rod/Crankshaft

Connecting rod small end I.D.

Use a dial gauge to measure the I.D. of connecting rod small end. If the measurement exceeds the limit, replace the connecting rod.

Connecting rod small end I.D. : 23.040mm

Tool: Dial Gauge (18-35mm)

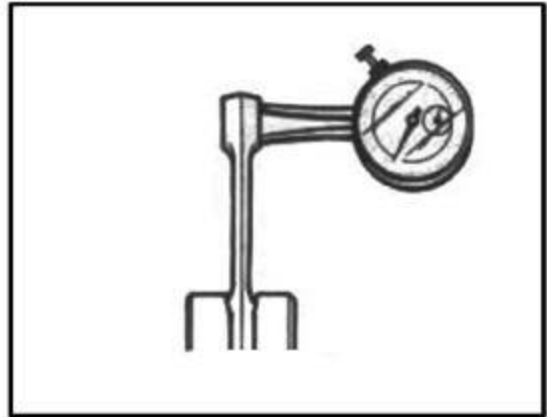

Connecting Rod Deflection

Check the movement of the small end of the rod and inspect the wear of the small end. This method is also applicable to check and inspection of big end.

Connecting Rod Deflection: 3.0mm

Tools: Dial Gauge

Magnetic stand

V-block

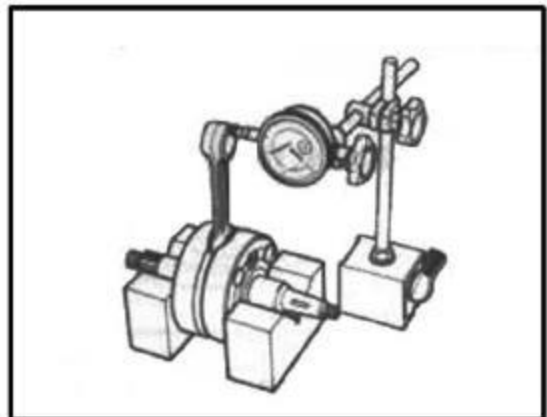

Connecting Rod Big End Side Clearance

Push the big end to one side, and use thickness gauge to measure the other side clearance. If out of limit, replace with a new crankshaft.

Connecting Rod big end side clearance: 1.0mm

Tool: Thickness Gauge

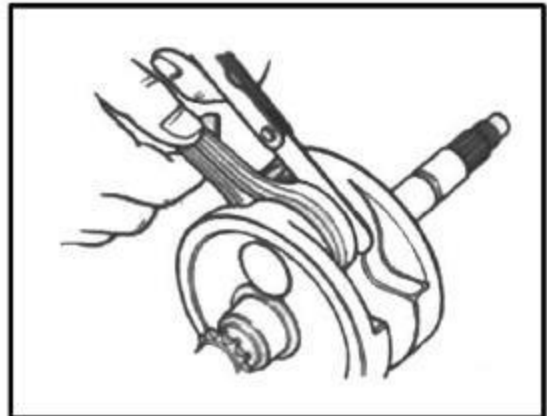

Crankshaft Run-out

Support crankshaft with "V" blocks as illustrated. Put the dial gauge, slowly turn the crankshaft and measure run-out with a dial gauge.

If the run-out exceeds the limit, correct or replace the crankshaft.

Run out limit: 0.08mm

Tools: dial gauge

Magnetic stand

V-block

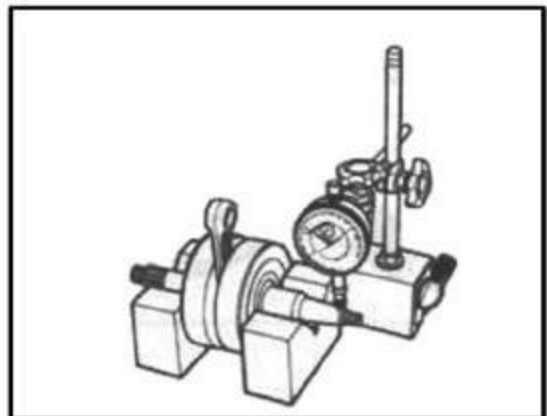

Drive Pulley,Driven Pulley,Drive Belt

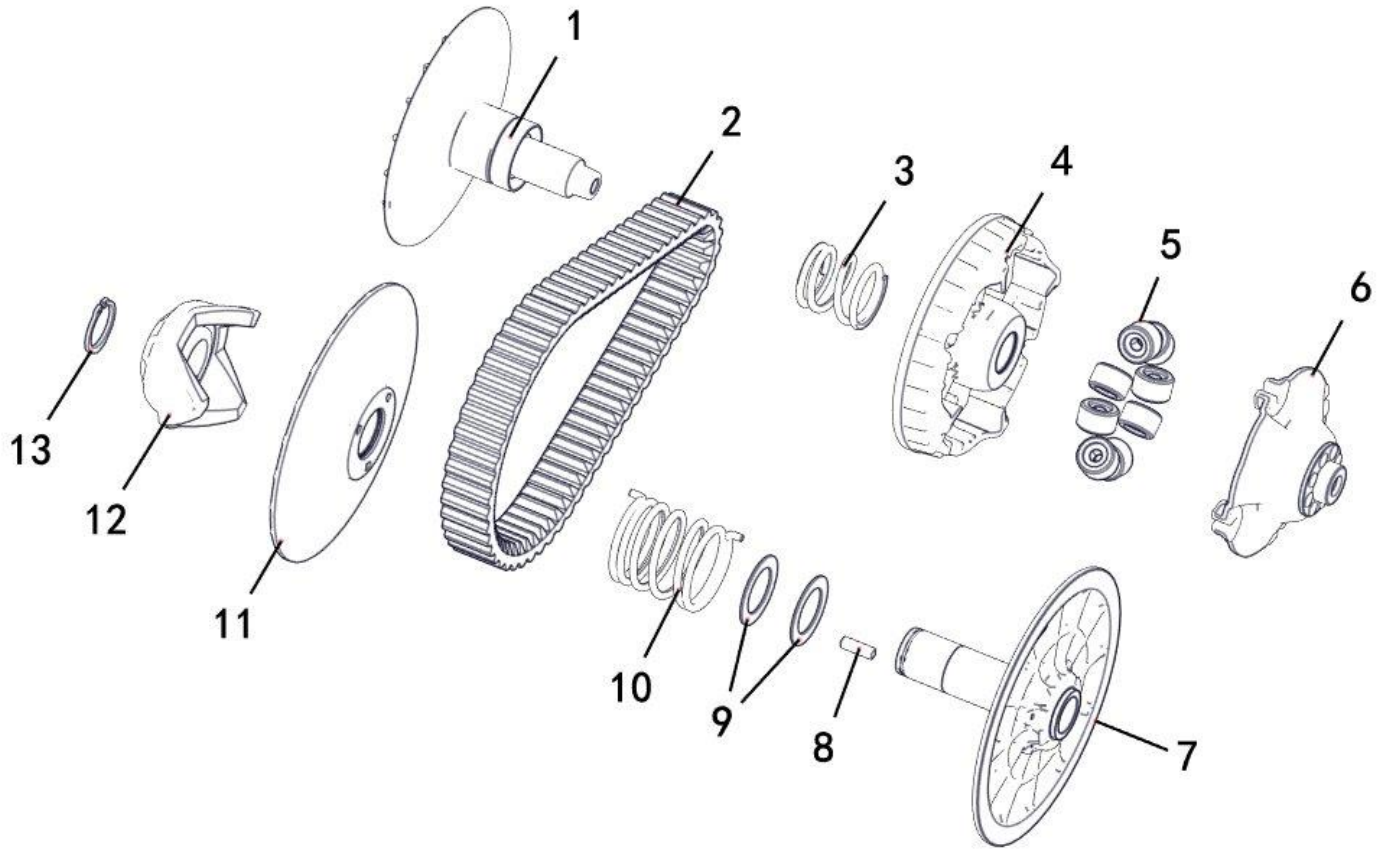

No.	Name
1	Drive Pulley Fixed Sheave
2	Drive Belt
3	Spring, Drive Pulley
4	Drive Pulley Sliding Sheave
5	Centrifugal Weight
6	Cam
7	Driven Pulley Fixed Sheave

No.	Name
8	Locating pin
9	Adjusting Washer
10	Spring, Driven Pulley
11	Driven Pulley Sliding Sheave
12	Spring Holder
13	Cir-clip

Drive Pulley

Disassembly

Remove Cam ① and Centrifugal Weight ②

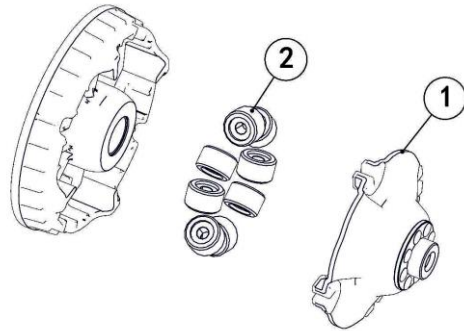

Centrifugal Weight Inspection

Inspect Centrifugal Weight and Sliding surface for wear or damage, Replace a set of centrifugal weight if abnormal.

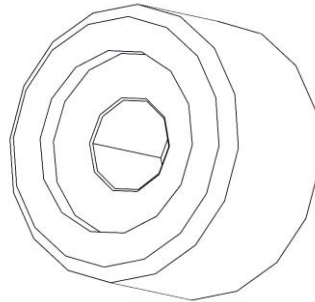

Note: Centrifugal Weight should be replaced by complete set.

Drive Pulley Fixed and Sliding Sheave Inspection

Inspect the abnormal conditions of drive surface for multi-step wear or other damage. Replace it if abnormal.

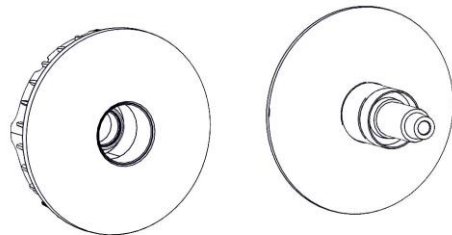

Inspect one-way clutch if equipped. Replace it if abnormal.

Driven Pulley

Disassembly

Note: Before disassembly, mark on the spring installation holes

Spring Installation Holes Marks

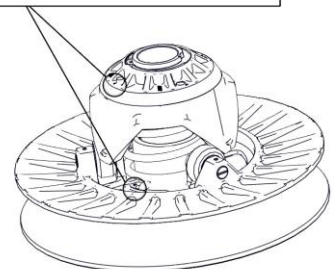

As the illustration shows, place driven pulley on the special tool base.

Special tool: Driven pulley spring compressor
(1BA-17730-00 FZ/1)

Turn special tool handle to compress the cam and spring. Using a cir-clip remover(pincer), remove cir-clip.

Note: Use special tool to remove cir-clip in order to avoid any wounding if spring seat flying up.

Slowly loosen tool handle to release the spring tension and remove the special tool(pincer);

Remove cam; Remove guide pin;

Remove spring and sliding sheave of driven pulley.

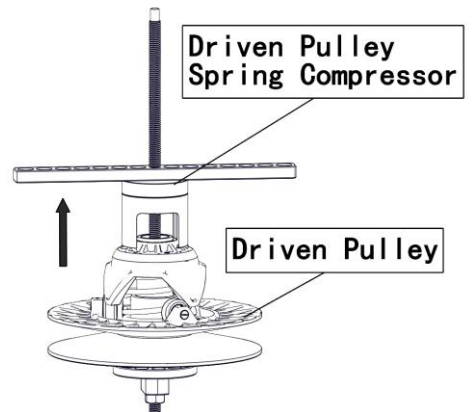
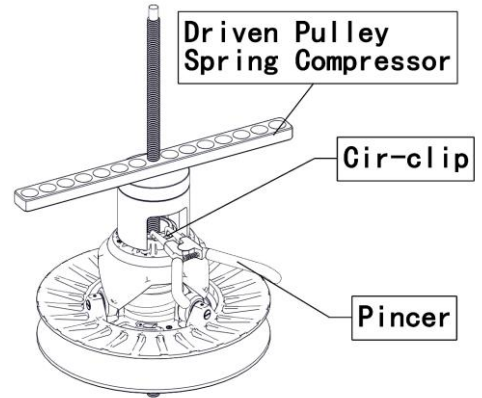
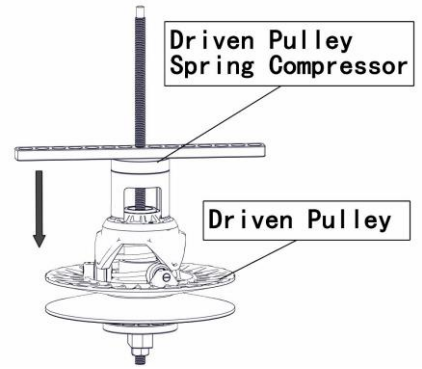

Driven Pulley Inspection

Driven Pulley Fixed Sheave Inspection

Check driven pulley faces for any abnormal conditions, such as heavy wear or visible damage. Replace if necessary.

Note: Clean fixed sheave of driven pulley before inspection.

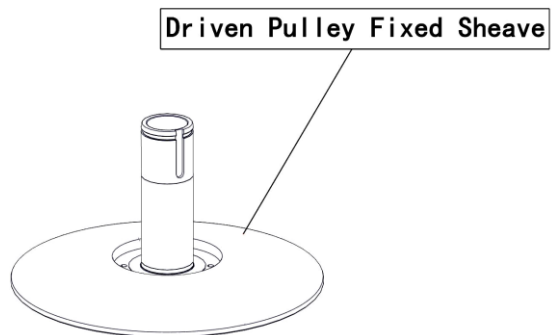

Note: Driven pulley assembly is precisely matched.
 If only fixed sheave or sliding sheave is replaced, the vibration may increase. It's recommended to replace both when necessary.

Driven Pulley Sliding Sheave Inspection

Inspect the drive face of sliding sheave for heavy wear and damage. Replace it if necessary.

Inspect the 3 sliders on driven pulley for wear and other damages. If the wear is severe ,replace all 4 sliders at the same time.

Cam Inspection

Check spring cam sliding face for wear and other damages. Replace if necessary.

Driven Pulley Spring Inspection

Check spring free length. If it is shorter than limit length, replace it.

Spring free limit length :

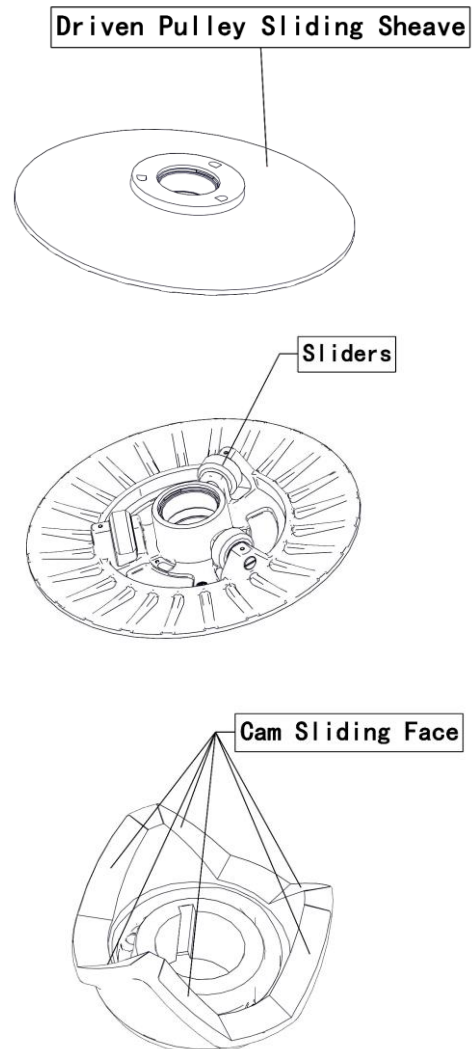

Drive belt

- Check belt for any greasy substance.
- Check contact surface of belt for any cracks and damage.
- Check belt width with vernier caliper.

Damage, width out of range: →Replace

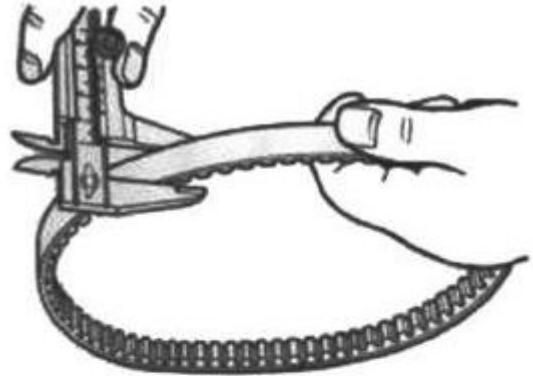

Belt width service limit: 33.5mm

Tool: vernier caliper

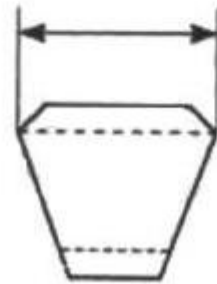

Caution:

If belt surface is stained with grease or oil, degrease the belt thoroughly.

Transmission

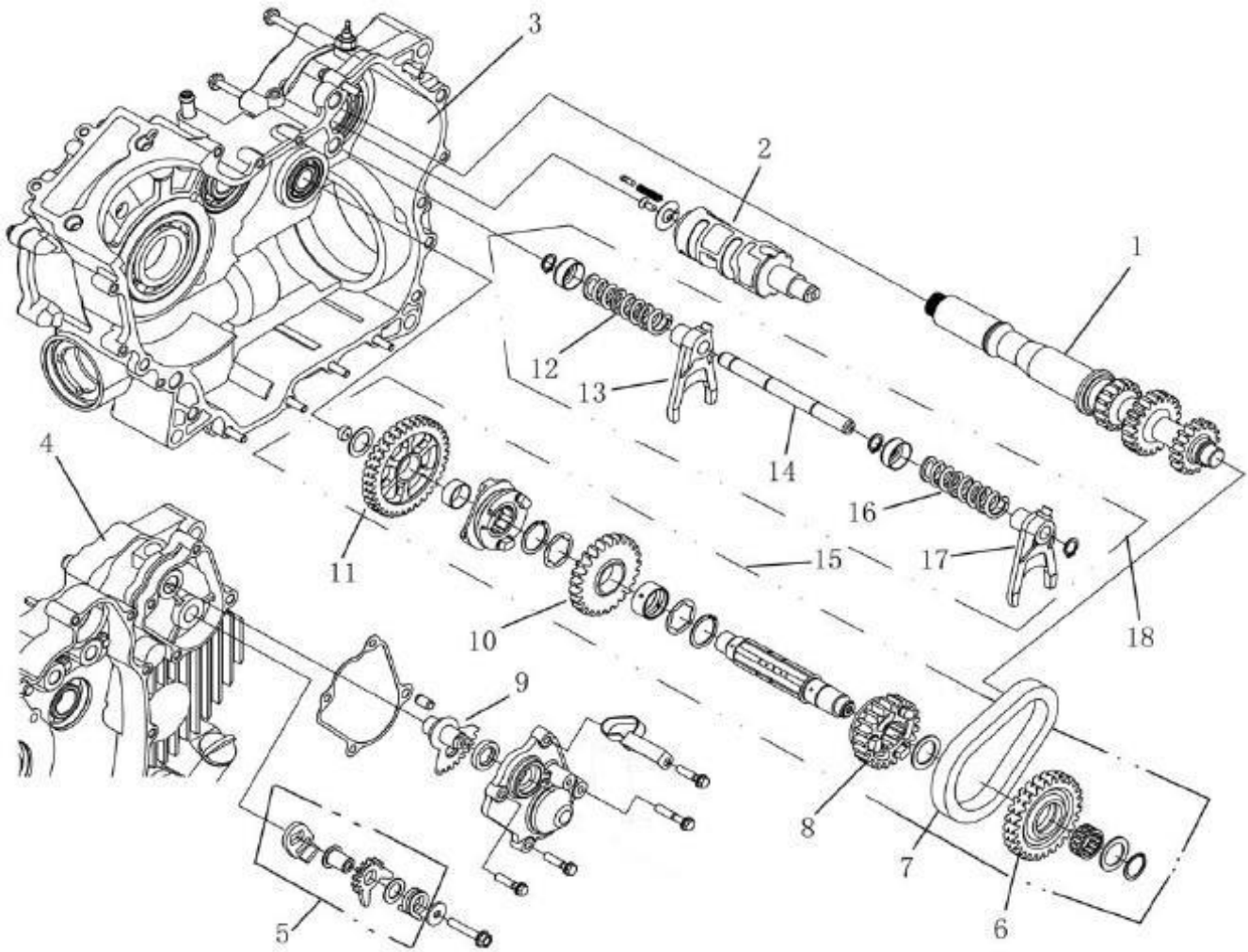

No.	Description	Qty	No.	Description	Qty.
1	MAIN SHAFT. GEARSHIFT	1	10	DRIVEN GEAR, HIGH RANGE	1
2	SHIFT CAM	1	11	DRIVEN GEAR, LOW RANGE	1
3	RIGHT CRANKCASE	1	12	SPRING, SHIFT FORK	1
4	LEFT CRANKCASE	1	13	RIGHT SHIFT FORK	1
5	DRIVEN SECTOR GEAR	1	14	GUIDE BAR	1
6	SPROCKET, REVERSE GEAR	1	15	DRIVEN SHAFT	1
7	CHAIN, REVERSE GEAR	1	16	SPRING, SHIFT FORK	1
8	DRIVEN OUTPUT GEAR	1	17	LEFT SHIFT FORK	1
9	DRIVE SECTOR GEAR	1	18	SHIFT FORK ASSEMBLY	1

Inspection

Check main shaft gear and sprocket surface for any damage or over wear.

Damage or over wear: → Replace

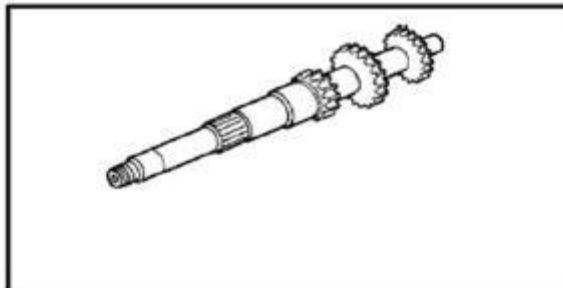

Check reverse gear chain for any damage or over wear.

Damage or over wear: → Replace



Disassemble driven shaft as illustrated.

Check each gear surface for any damage or over wear.

Check bearing and collar for any wear or damage..

Damage or over wear: → Replace

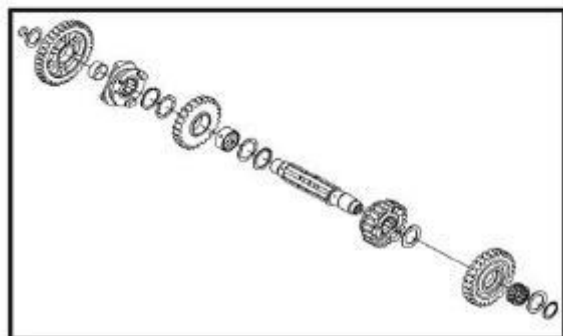

Check the shift fork clearance with a thickness gauge in the groove of its gear.

Clearance exceeds the limit: → Replace

Shift fork to Groove clearance

Standard clearance :0.10-0.30mm

Service Limit :0. 50mm

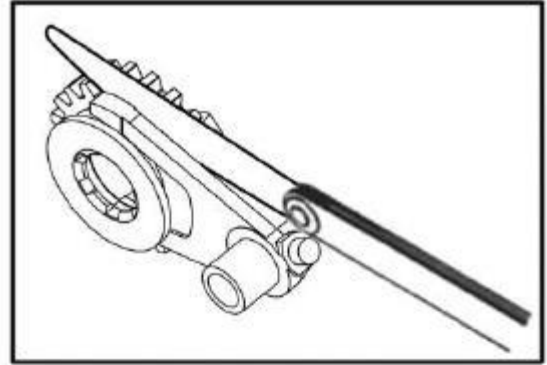

Measure shift fork groove width with vernier caliper

Standard shift fork groove width: 6.05-6.15mm

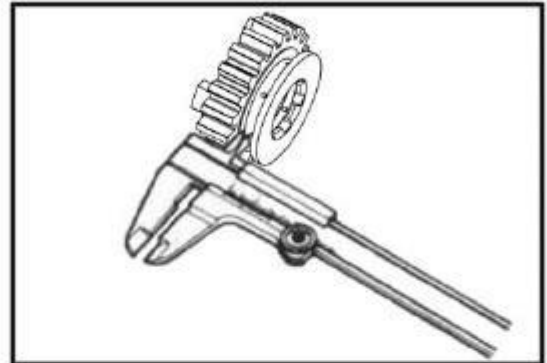

Measure shift fork thickness with vernier calipers;

Standard fork thickness: 5.08-5.90mm

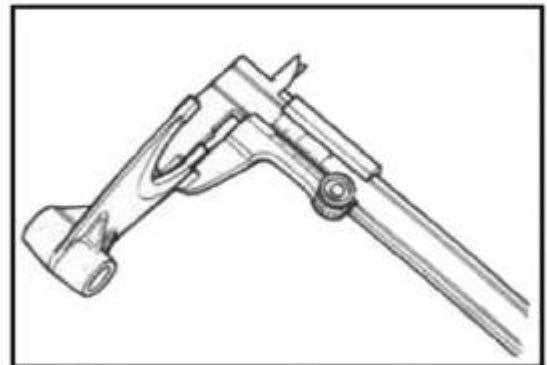

Check shift fork ① and ② for damage or bend

Damage, bend: → Replace

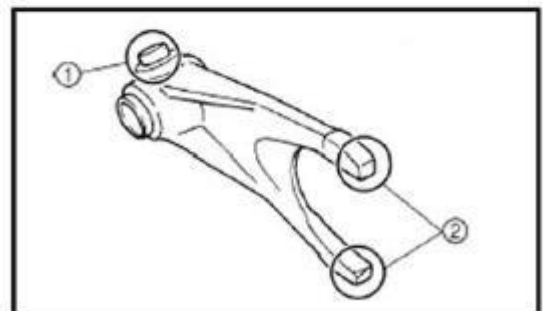

Install shift fork to guide bar and move left and right.
In case of any unsmooth moving, replace with a new one.

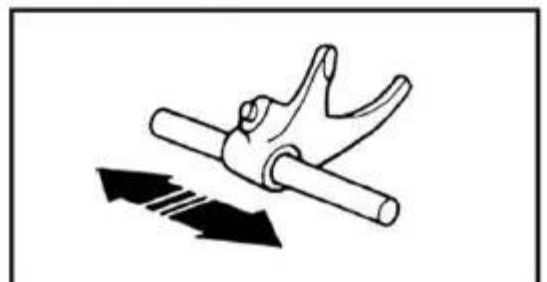

Put the guide bar on a flat plate and roll it. In case of any bend, replace with a new one.

NOTE: DON NOT attempt to correct a bent guide bar.

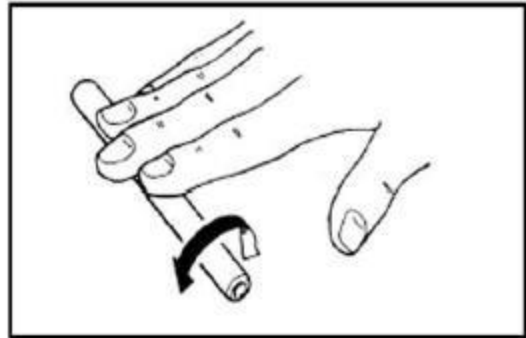

Check shift fork spring for breakage, damage
Broken or damaged: → **Replace**

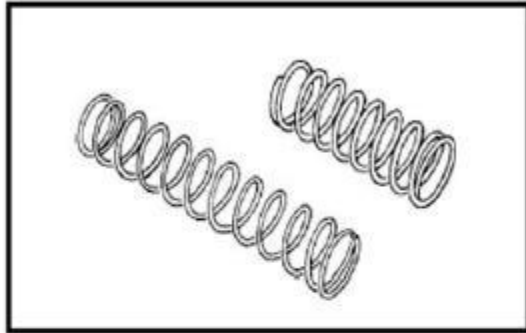

Check shift cam groove for scratches, damage.
Scratch or damage: → **Replace**

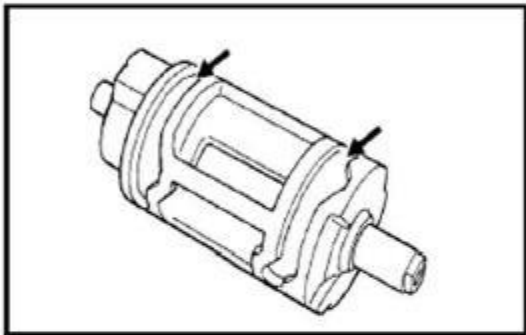

Assembly

Reverse the removal procedure for assembly. Pay attention to the following:

Use new retainers. Pay attention to the direction of the retainers. Fit to the side where the thrust is as illustrated.

Coat the gears and shafts with engine oil before assembly.

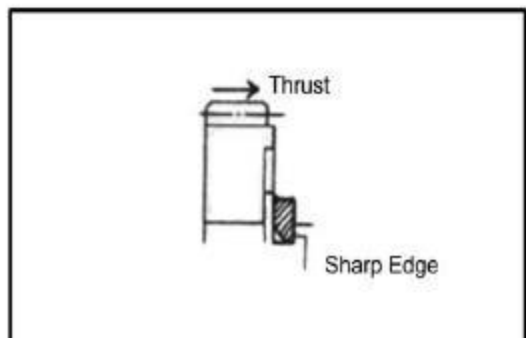

Note:

- Do not reuse the retainers
- Do not expand of the gap end of new retainers too wide when assembling.
- Make sure that all the retainers are properly fitted.

When assembling the guide bar, take care not to assemble the two shift forks and springs in the opposite direction.

- 1. Guide bar
- 2. Retainer
- 3. Left shift fork
- 4. Shift fork Spring (small)
- 5. Right shift fork
- 6. shift fork spring (big)
- 7. Spring seat

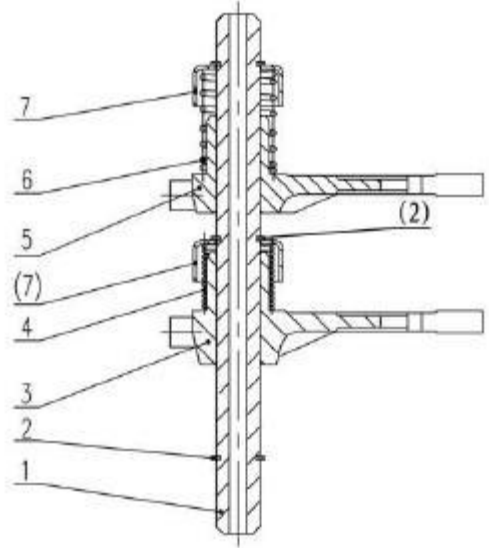

OIL PUMP

Disassembly oil pump as illustrated:

- 1. Oil pump housing
- 2. Dowel pin
- 3. Oil pump shaft
- 4. Straight pin
- 5. Inner rotor, oil pump
- 6. Outer rotor, oil pump
- 7. Oil pump cover

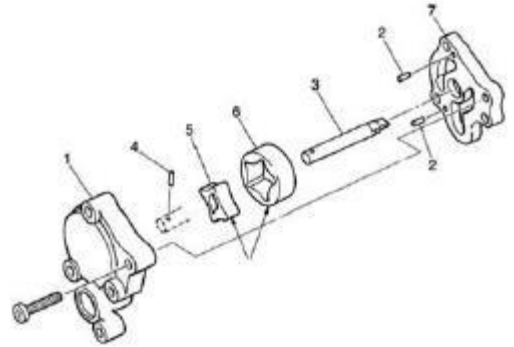

Check oil pump housing and cover for cracks and damage.

Crack or damage: → Replace

Measure top clearance “a” between inner and outer rotors and side clearance “b” between outer rotor and oil pump housing. If the clearance exceeds the limit, replace with new one.

Top Clearance: 0.03-0.10mm
Service Limit: 0.15mm

Side clearance: 0.03-0.10mm
Service Limit: 0.12mm

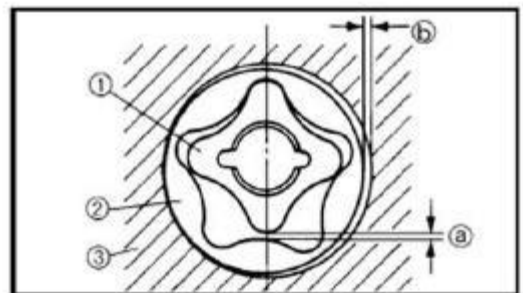
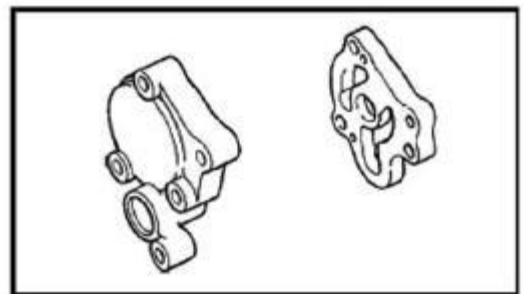

Oil strainer

Check oil strainer ① and O-ring ② for damage

Damaged oil strainer: → Replace

Clean the surface of oil strainer with engine oil

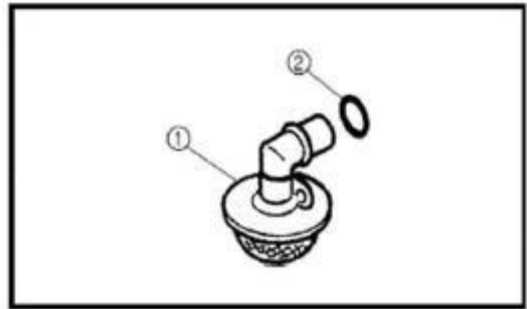

Relief Valve

Check the valve body ①, valve ② and spring ③ O ring ④ for damage or wear.

Damage or wear: → Replace

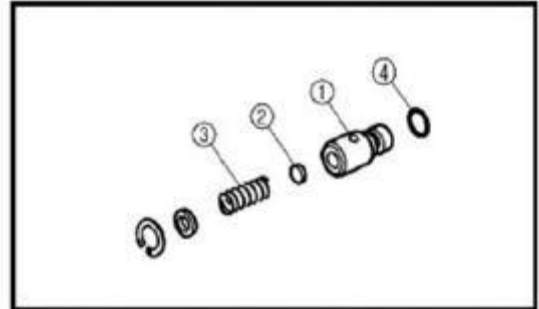

Drive Bevel Gear

Use a clean rag to protect the drive bevel gear shaft, clamp it to the pliers.

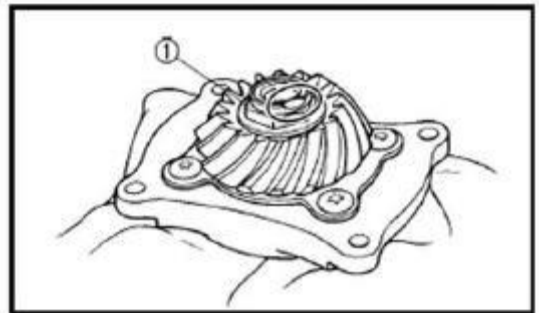

Loosen drive bevel gear nut 3, remove the drive bevel gear 4 and adjust washer 5

Check the drive bevel gear 4 and output driven gear 2 for rust, scratch, wear or damage. Replace if any.

Check if the bearing 8 turns smoothly, replace with a new bearing if necessary.

Adjust Washer 5 if any of right crankcase, drive bevel gear 4, or drive bevel gear cover 1 is replaced. Refer to bevel gear adjustment for details.

Apply engine oil to bearing 8 when assembling and tighten nut 3 to the specified torque.

- 1. Drive bevel gear cover
- 2. Output driven gear
- 3. Drive bevel gear nut
- 4. Drive bevel gear
- 5. Adjust washer
- 6. Drive bevel gear shaft
- 7. Bearing press
- 8. Bearing

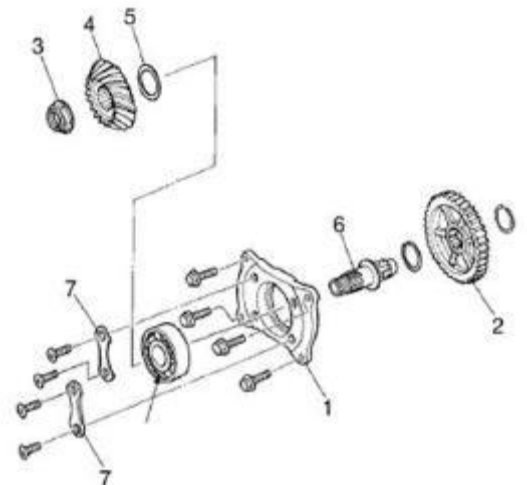

Drive bevel gear nut

Tightening torque: 145N•m

Front Output Shaft

Check bearing 7 for smooth turning and abnormal wear. Check oil seal 5 for damage.

Wear or damage: → **Replace**

Apply lubrication oil to bearing 7 and oil seal 5 lip before assembly.

Apply thread locker to bearing limit nut 6 (left thread) and tighten to the specified torque.

Bearing limit nut Tightening torque: 80N•m

Tighten Nut 1 to the specified torque

Front output shaft nut tightening torque: 97N•m

Driven Bevel Gear

Remove nut 19, washer 18, coupler 17 and oil seal 16.

Protect end thread of driven bevel gear with proper device ②. Fix bevel gear cover 14 and press out driven bevel gear.

Place a clean rag ① under bevel gear cover.

Remove bearing limit nut 10 with special tool ② and remove bearing.

Check driven bevel gear 8 surface for scratches, wear. Scratch or wear: → Replace

Check free turning of bearing 9 and 11. Replace with a new one if any abnormal is found.

Use new oil seal 16 and O-ring 12 when assembling.

Adjust washer 13 if any of right crankcase, driven bevel gear 8 or driven bevel gear cover 14 is replaced. Refer to bevel gear adjustment for details.

Apply lubrication oil to bearing 9 and 11 and oil seal 16, O-ring. Apply thread locker to nut 10 and tighten to the specified torque.

Tightening torque :110N•m

Tool: driven bevel gear nut wrench

Driven bevel gear nut tightening torque:150N•m

Bevel Gear Washer Adjustment

Adjust washer ① and ② when replacing crankcase and/or bevel gear and/or bevel gear cover,

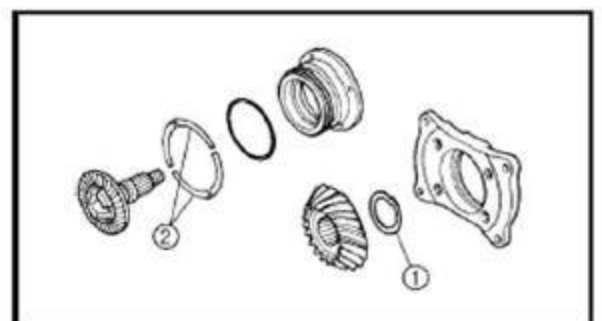
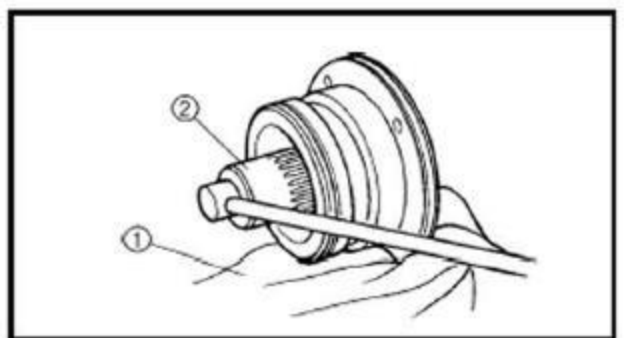
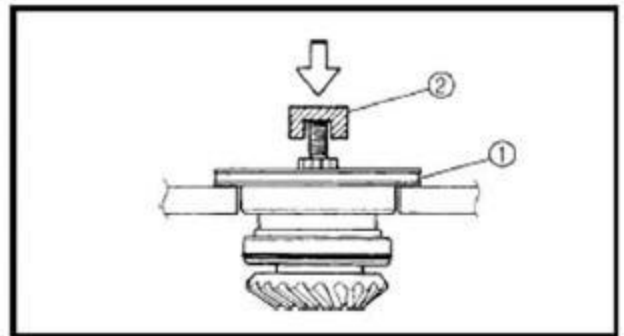
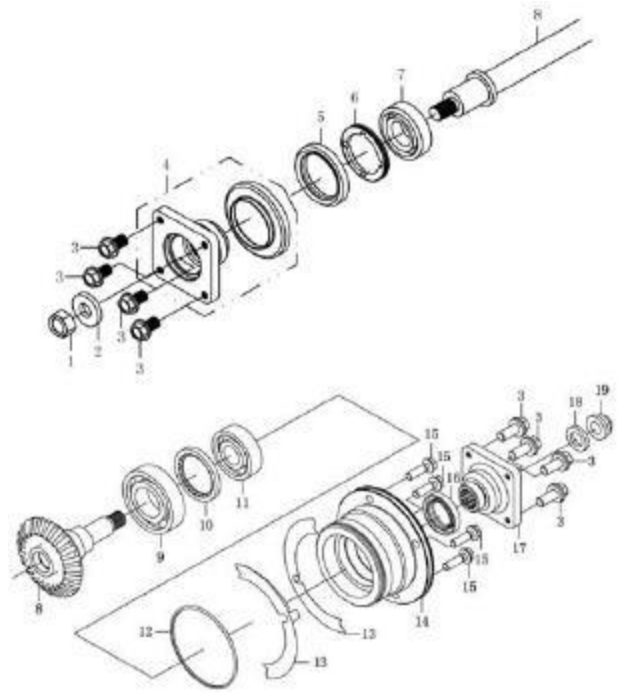

Bevel Gear

Note: Proper bevel gear engagement depends on that the gear backlash and tooth contact are within the proper range.

Bevel Gear Backlash

Install drive and driven gears to the crankcase. Wrap a (-) screwdriver ③ with a rag ② and insert it into the speed sensor hole ① of left crankcase to fix the drive bevel gear.

Install special tool ③ and micrometer ④.

Tool: Bevel gear side clearance dial gauge

Micrometer

a=46mm

Turn the driven bevel gear in each direction and measure the backlash.

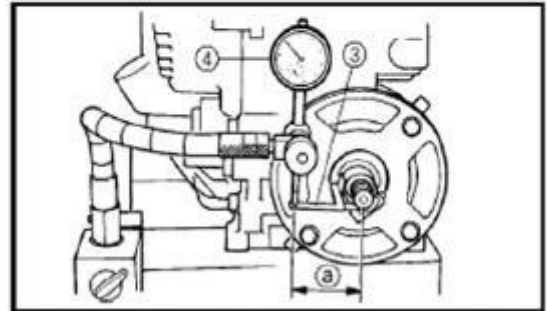
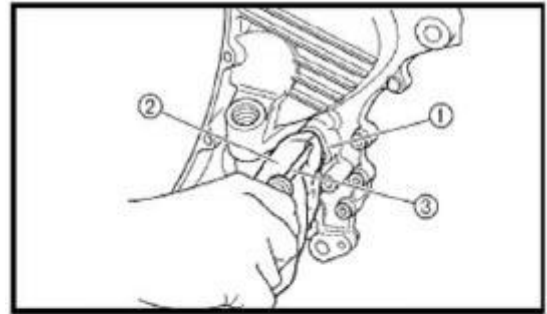

NOTE: Measure four points in the mutual vertical direction

If the backlash is not within the specification, adjust the thickness of the driven bevel gear adjust washer. Re-check the backlash until the backlash is correct.

Bevel Gear Backlash: 0.1-0.2mm

Adjustment

Measured Backlash	Washer Thickness Adjustment
<0.1mm	Decrease washer thickness
0.1~0.2m	Correct
>0.2mm	Increase washer thickness

Tooth Contact

After adjusting the backlash, check the tooth contact according to the following procedures:

Remove drive and driven bevel gear shafts from crankcase;

Clean and degrease every tooth of drive and driven bevel gear;

Coat the driven bevel gear with machinist's layout dye or paste;

Install drive and driven bevel gear;

Rotate the driven bevel gear several turns in both directions;

Remove drive and driven bevel gear shafts and check the coated teeth of the drive bevel gear;

Refer to the illustration on the right for tooth contact pattern ①, ② and ③

- ① Incorrect (contact at tooth top)
- ② Correct
- ③ Incorrect (contact at tooth bottom)

If tooth contact is correct (Contact ②), continue the next procedure.

If tooth contact is not correct (② and ③), adjust the thickness of the washer of drive bevel gear. Repeat above steps to check tooth contact until it is correct.

Adjustment

Tooth Contact	Washer Adjustment
Contact at tooth top ①	Increase Thickness
Contact at tooth bottom ③	Decrease Thickness

Note:

After adjusting the tooth contact, the backlash must be checked again;
 If the backlash is adjusted but tooth contact is still out of specification, replace the drive and driven bevel gears;
 Both tooth contact and backlash should be within the required specification.

①

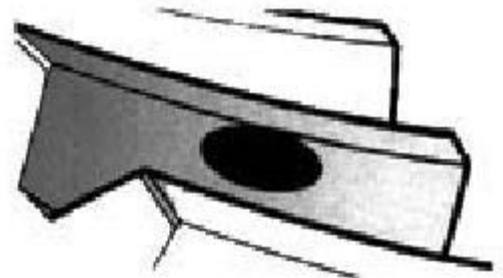

②

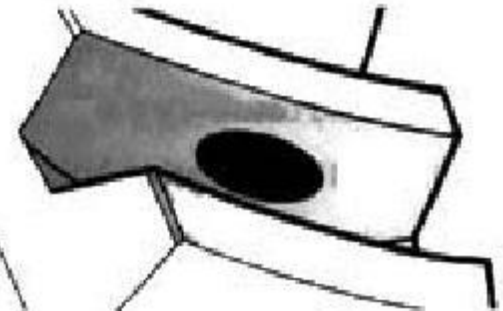

③

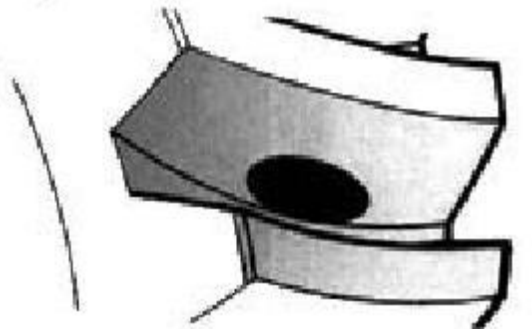

Balancer Shaft

Remove the parts as illustrated on the right. Check each part for abnormal wear or damage.

Wear or damage: → **Replace**

- ① Balancer shaft gear
- ② Woodruff key
- ③ Balancer shaft
- ④ Balancer shaft sprocket
- ⑤ Washer
- ⑥ Bolt

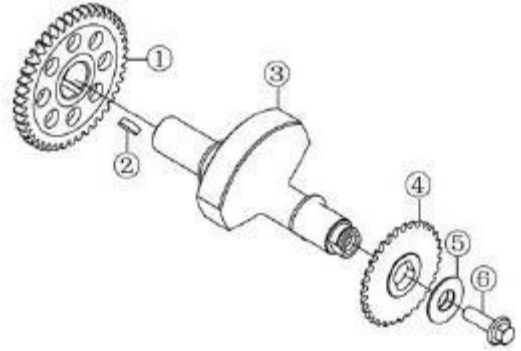

Magneto Rotor

Remove starter clutch nut;



Check starter clutch roller and holder for abnormal wear or damage.

Wear or damage: → **Replace**

Install the starter clutch in the correct direction.

Note:

When install the starter clutch to the magneto rotor, make sure side “A” is in the right direction.

Face arrow mark “B” to the engine side;
Apply engine oil to starter clutch.

Apply thread locker to bolt and tighten to the specified torque:

Tightening torque of starter clutch bolt: 30N•m

Material: Thread Locker

Install the starter driven gear

Make that the starter driven gear turns in the opposite direction of the arrow mark “B”. The gear cannot turn in the direction of the arrow.

Check starter driven gear bearing. In case of anything unusual, replace the bearing.

Remove starter driven gear bearing with special tool

Install starter driven gear bearing with special tool.

Tool: Bearing Installer/Remover



Electric Starter Gear

Check the gear surface for scrap or damage.

Scrape or Damage: → Replace

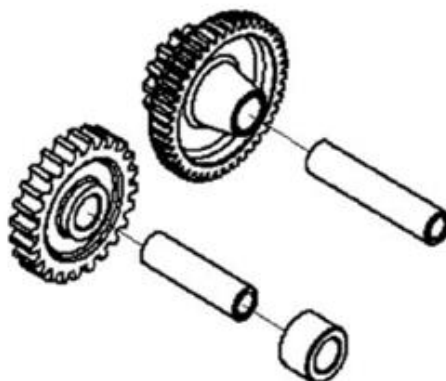

LEFT CRANKCASE COVER (MODEL2)

Check magneto stator coil 2, pickup coil 3 for damage, burn or short circuit, if any, replace with new one;

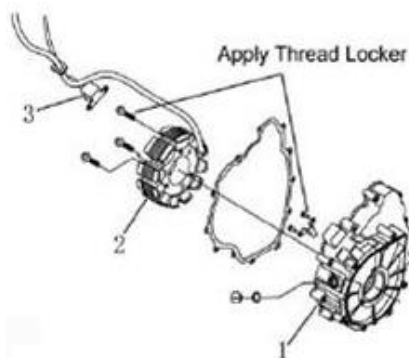

LEFT SIDE COVER

Disassembly

- 1— Left side cover
- 2— End cap

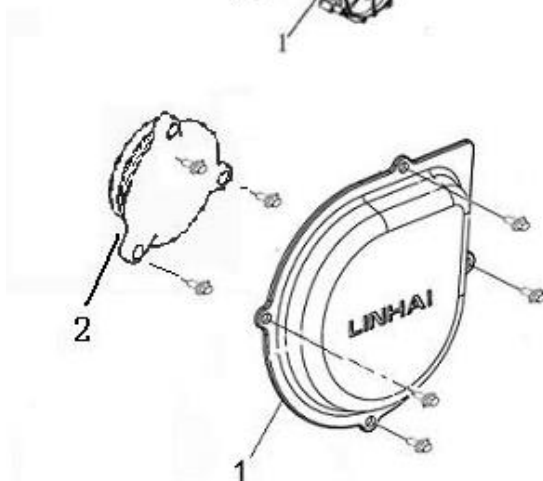

CVT Cover

Inspect CVT Cover for cracks. Replace a new CVT Case if necessary.

Inspect CVT Gasket for ageing, damage. Replace a new one if necessary.

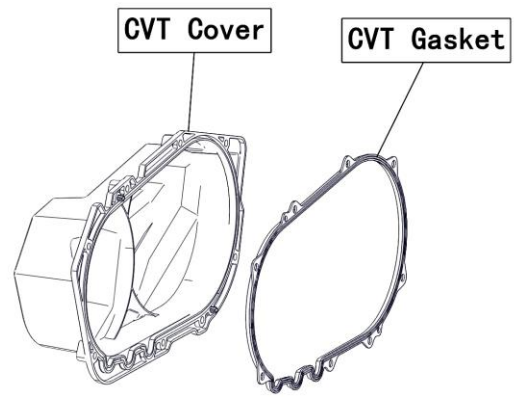

CVT Case

Check bearing ① for smooth turning. In case of any abnormal, remove screw ② and bearing retainer ③ and replace with a new bearing.

Check oil seal ④. In case of any damage, replace it;

Apply grease to oil seal lip and install with special tool.

Apply lubrication oil to bearing ① and install with special tool; Check bearing for smooth turning. The seal side of bearing ① should face bearing retainer ③.

Install bearing retainer ③ and bolt ②.

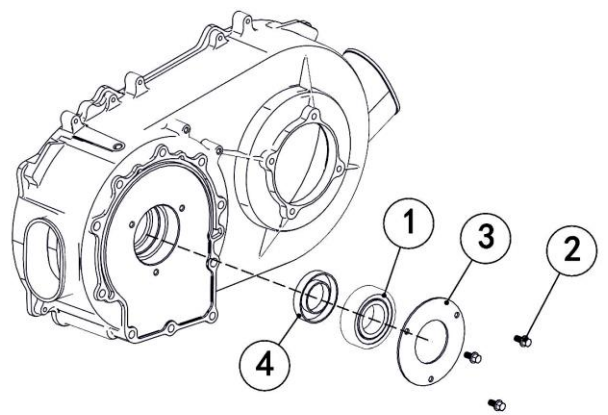

**Tool: Oil Seal Installer
Bearing Installer**

Crankcase

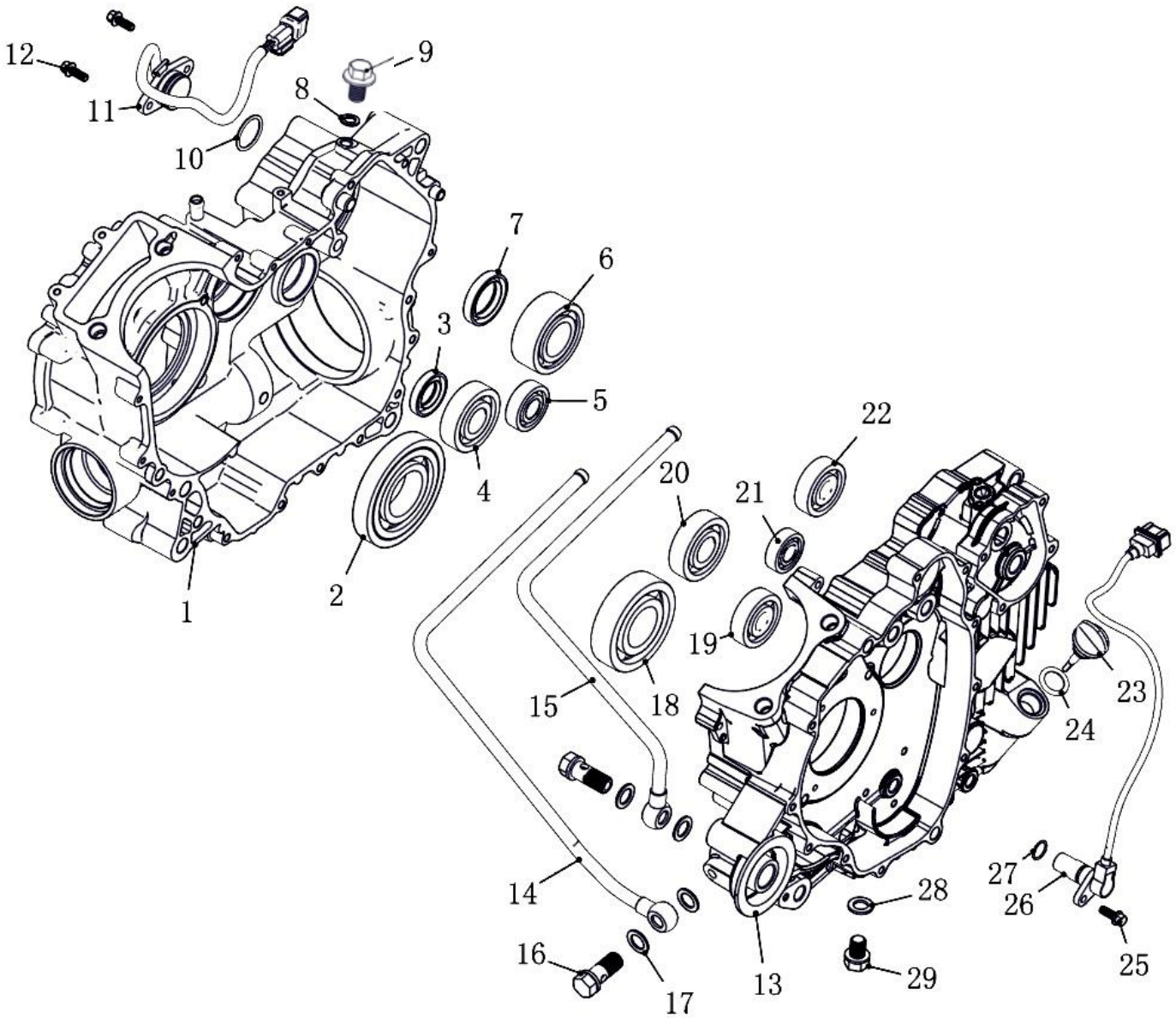

- 1.Right Crankcase
- 2.Bearing
- 3.Seal
- 4.Bearing
- 5.Bearing
- 6.Bearing
- 7.Oil Seal
- 8.Washer,Reverse Gear Sensor
- 9.Nut
- 10.O-ring

- 11.Gear Sensor
- 12.Bolt
- 13.Left Crankcase
- 14.Oil Pipe 1
- 15.Oil Pipe 2
- 16.Link Bolt
- 17.Washer
- 18.Bearing
- 19.Bearing
- 20.Bearing

- 21.Bearing
- 22.Bearing
- 23.Oil Dip Rod
- 24.O-ring
- 25.Bolt
- 26.Speed Sensor
- 27.O-ring
- 28.Washer
- 29.Oil Drainage Bolt

Clean and grease the bearings, turn the inner race of bearing and check the play, noise and smooth turning. In case of any abnormal, remove bearing with special tool and replace;
 Check all the oil seals for over wear or damage. In case of any over wear or damage, remove with special tool and replace with a new oil seal;
 Remove gear sensor (11) and check for continuity with reverse gear sensor (9) with a multimeter.
 Remove link bolt and oil pipe (14)(15) and check oil pipe for crack or clog. Replace with a new one if any;
 Remove oil drainage bolt (29) and clean it.

Note: Check bearing for smooth turning after installation.

Install new O-ring and apply grease;
 Install gear sensor;
 Install reverse gear sensor (9) and tighten to the specified torque.

Reverse gear sensor tightening torque: 20N•m

Install speed sensor (26)

Install oil pipe and tighten the link bolt to the specified torque;

Link bolt tightening torque: 40N•m

Install washer (28) and oil drainage bolt (29) and tighten to the specified torque;

Drain bolt tightening torque: 30N•m

**Tool: Bearing Remover
 Bearing Installer
 Multimeter**

III Engine Assembly

Reverse the engine removal procedure for installation.

Caution:
 Clean all the parts before assembly;
 Make sure that the parts are in good condition without any damage;
 Apply engine oil to the moving parts before assembly;
 Apply grease to oil seal lip and O-ring

Caution:
 Make sure that drive belt, primary and secondary sheaves are not stained with grease.

Engine Center

Oil Pump and Relief Valve

Install oil pump and relief valve to left crankcase, as illustrated on the right. Tighten to the specified torque:

Oil pump bolt: 10N•m

Relief valve bolt: 10N•m

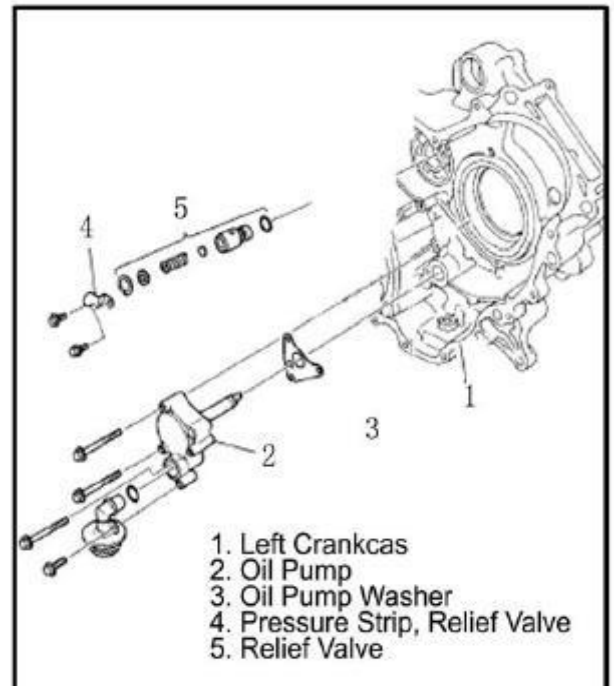
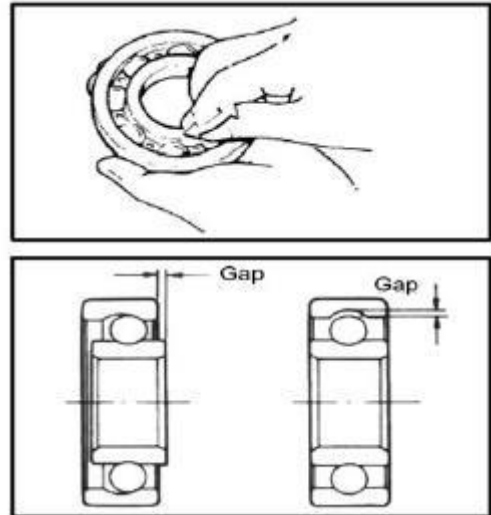

Connecting Rod

Install connecting rod to left crankcase with special tool;

Note:

Do not hammer the conrod into crankcase with plastic mallet;
Use special tool to avoid affect of conrod precision

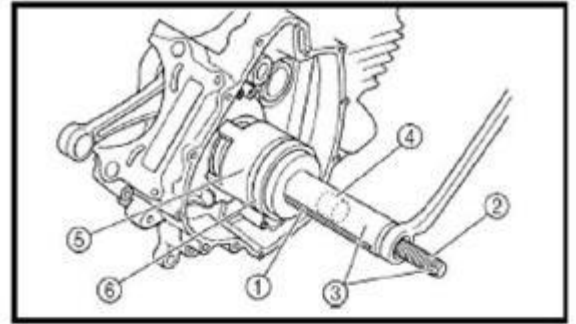

Tool: Conrod Installer

Balancer Shaft

Install balancer shaft

Caution: Balancer shaft driven gear should be aligned to the mark as illustrated.

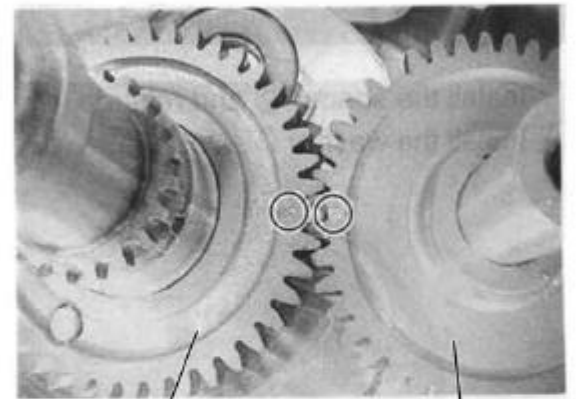

Drive Gear, Crankshaft Balancer

Driven Gear, Crankshaft Balancer

Main Shaft, Counter Shaft

Install main shaft and counter shaft.

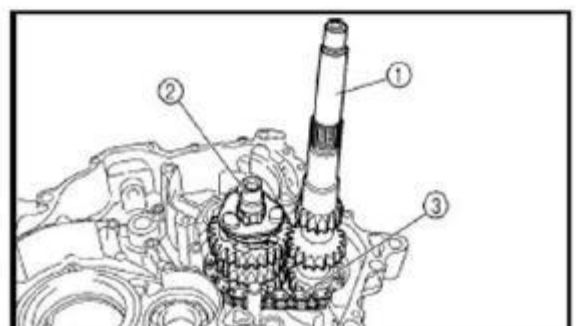

Shift Cam, Shift For

Install shift can① and shift fork②

Check each part for smooth turning

Install low range driven gear to counter shaft③

Spray adequate engine oil to each part.

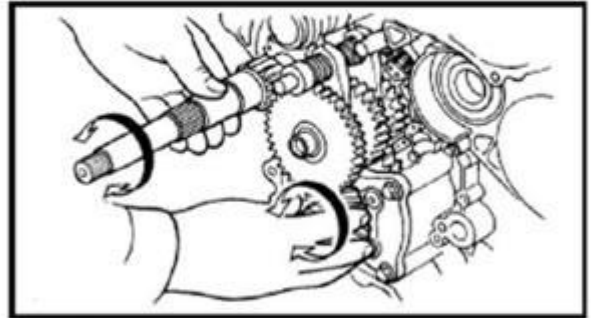
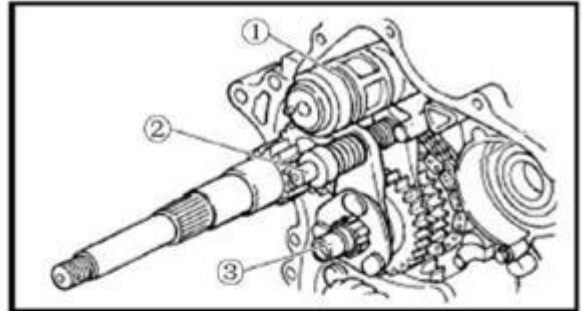

Drive Bevel Gear

Install drive bevel gear and tighten to the specified torque.

Drive bevel gear tightening torque: 32N. m
Material: Thread Locker



Right Crankcase

Driven Bevel Gear

Install driven bevel gear and tighten to the specified torque.

Driven bevel gear tightening torque: 25N. m

Check bevel gear backlash



Front Output Shaft

Install front output shaft to right crankcase



Apply sealant ① to the mating face of right crankcase.

Note: Apply sealant evenly in an uninterrupted thin line.

Install 5 dowel pins②

Assemble crankcase and tap slightly with a rubber hammer so that the crankcase is properly fitted.

Install bolt and tighten to the specified torque.

**Crankcase bolt tightening torque: M6: 10N•m
M8: 25N•m**

Note: Crankcase bolts should be tightened diagonally in several steps.

Place the steel ball and install gear positioning bolt and tighten the bolt to the specified torque.

Gear positioning bolt tightening torque: 40N•m

Engine Right

Timing Chain

Put on timing chain (2)

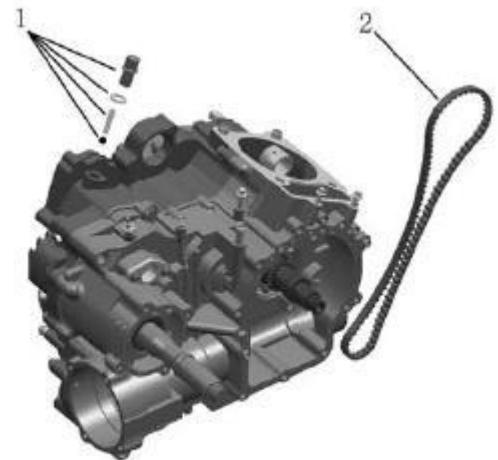

CVT Case

Install dowel pin ①, gasket ② and gasket ③ to the right crankcase. Install CVT case assembly to right crankcase.

Install bolt ④ and lock plate ⑤, lock plate ⑦, bolt ⑤

Note: Tighten bolt/nut diagonally
Use a new gasket

Install air guide plate ⑧ and bolt ⑨.

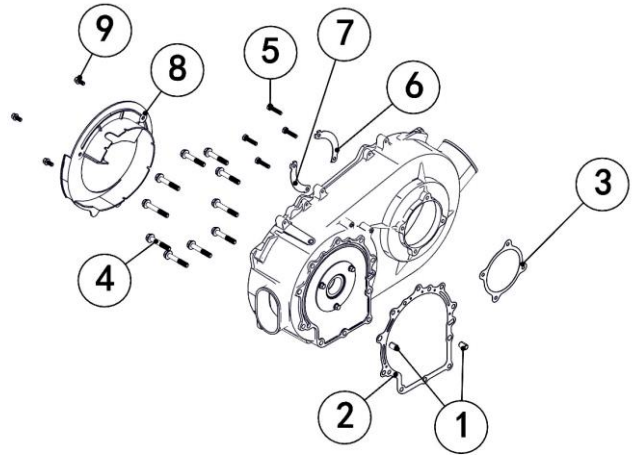

Drive pulley, driven pulley, drive belt

Use bolt M6X70(full thread) to open fixed plate and sliding plate.

Install drive belt on drive pulley and driven pulley

Warning: Drive belt contact surface should be free from any grease or oil

Install CVT assembly and tighten bolt washer and nut to the specified Torque

Note: Install bolt of primary sheave anticlockwise. Install nut of secondary sheave clockwise.

Drive pulley bolt tightening torque: 55~60N.m

Driven pulley nut tightening torque: 110~120N.m

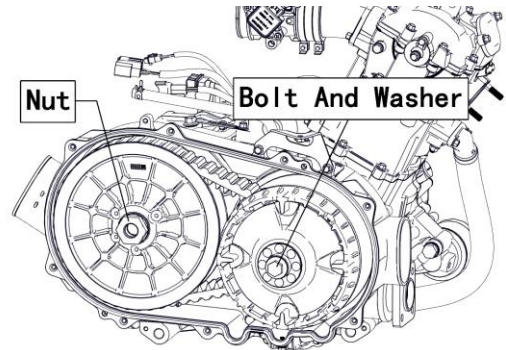
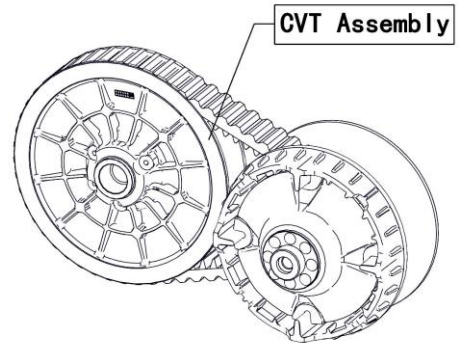
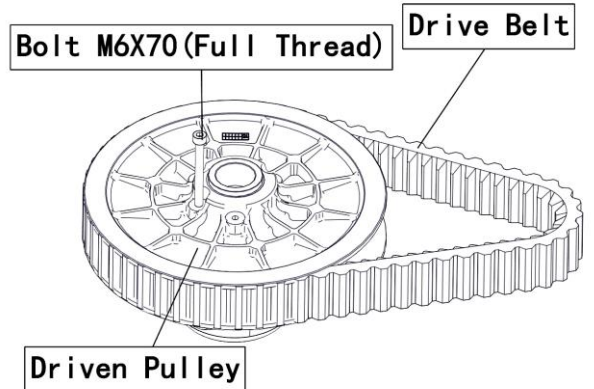

CVT Cover

Install the CVT gasket and CVT cover.

Install CVT cover bolts and tighten diagonally in several steps.

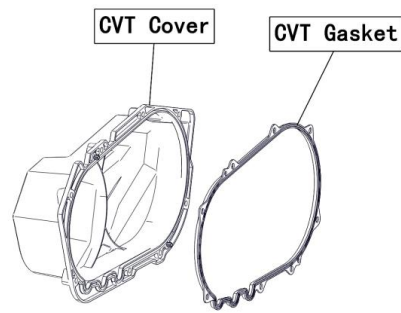

Engine Left

Oil Pump Sprocket and Chain

- Install oil pump drive sprocket;
- Install oil pump driven sprocket;
- Install oil pump drive chain;
- Install oil pump sprocket bolt;
- Install sprocket retainer with a long nose pliers

Tool: Long Nose Pliers

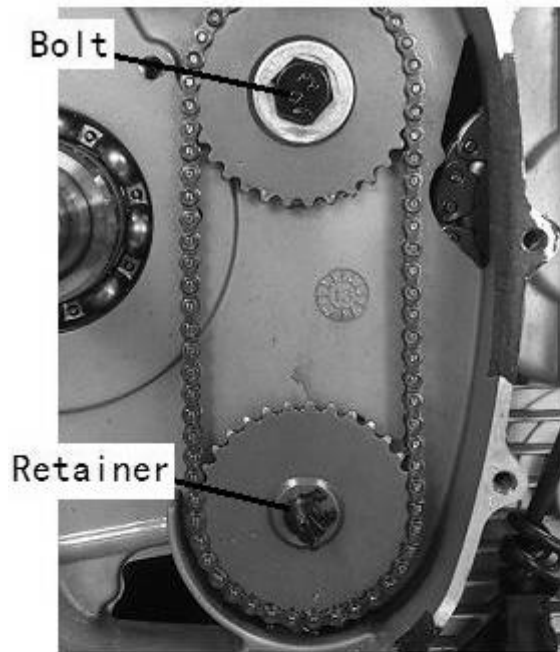

Dual Gear, Idle Gear

- Install dual gear shaft ① and dual gear ②
- Install dual gear shaft ③, dual gear ④ and bush ⑤



Starting Driven Gear

- Install starting driven gear bush ⑥

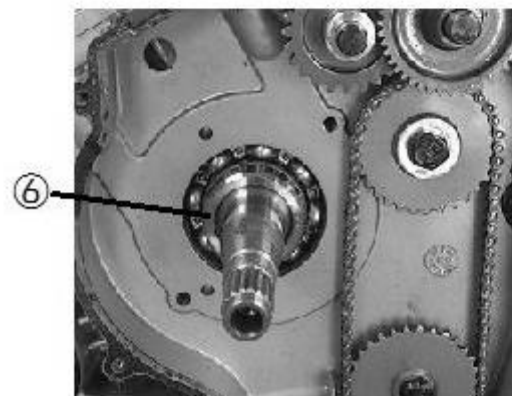

Install starting driven gear;

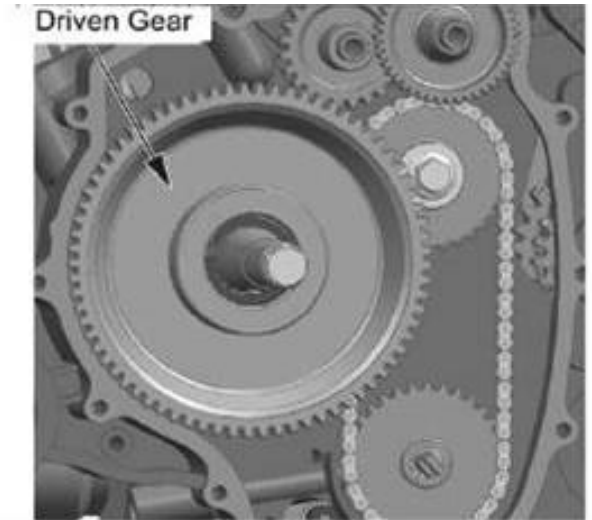

Magneto Rotor

Install Magneto Rotor (1)
Install Nut (2)
Nut tightening torque: 160N•m

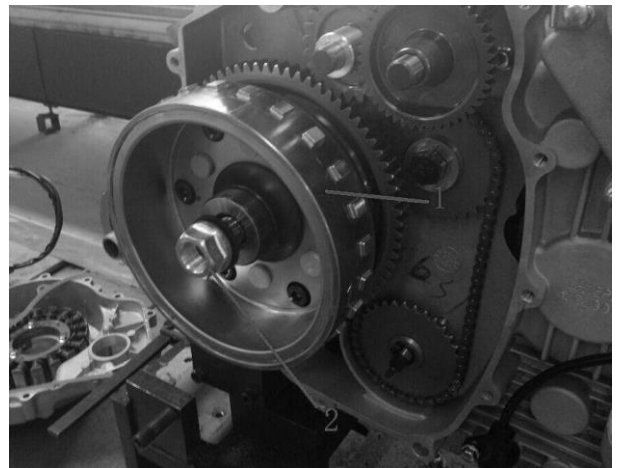

Install left crankcase cover (1)
Install end cap (2)

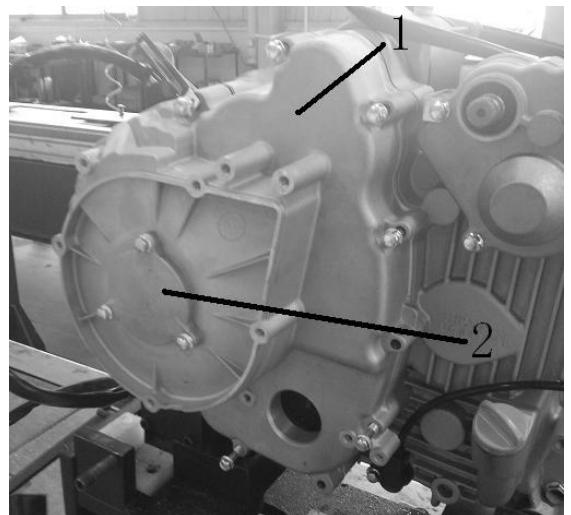

Water Pump

Install water pump;

Install water pump fixing bolts;

Note: Before tightening the bolts, be sure to insert oil pump shaft into groove of water pump shaft.

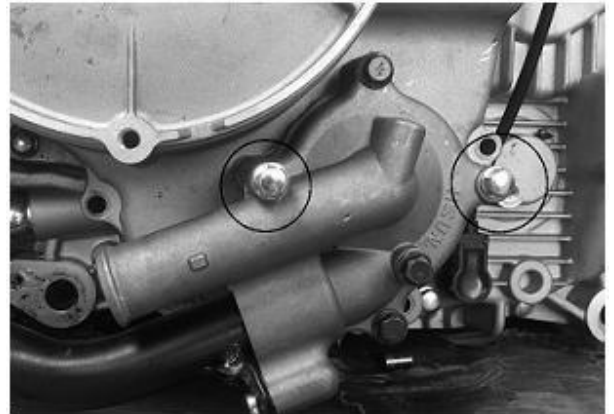

Sector Gear

Install the parts as illustrated on the right.

- 1- sector gear cover and gasket
- 2-dowel pin
- 3-drive sector gear
- 4-driven sector gear
- 5-driven sector gear bolt

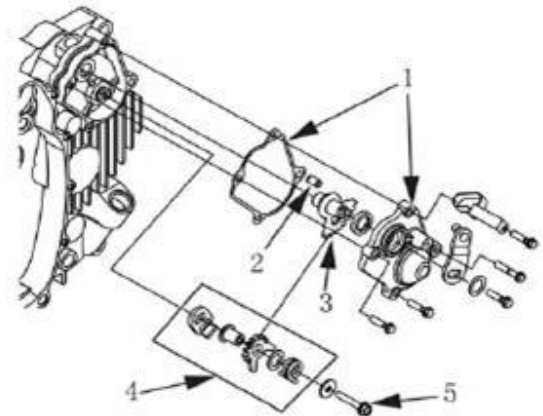

Note: When the shift cam is in the neutral position, the mark of drive sector gear should be between the two marks of the driven sector gear.



Driven sector gear tightening torque: 14N•m

Oil Filter

Install oil filter bolt and tighten to the specified torque;

Oil filter bolt tightening torque: 36 N·m

Apply engine oil to O-ring;

Install oil filter, turn it by hand until the filter gasket contacts the mating surface. Tighten the bolts to the specified torque.

Tool: Oil Filter Wrench

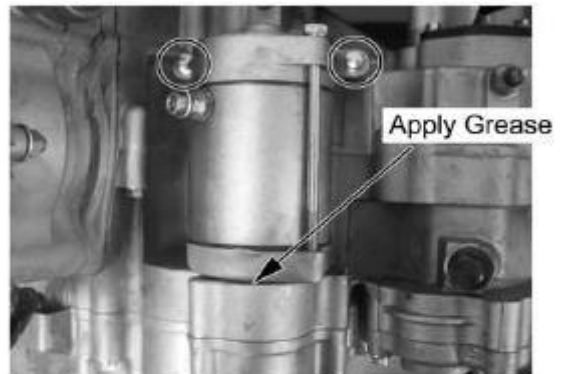
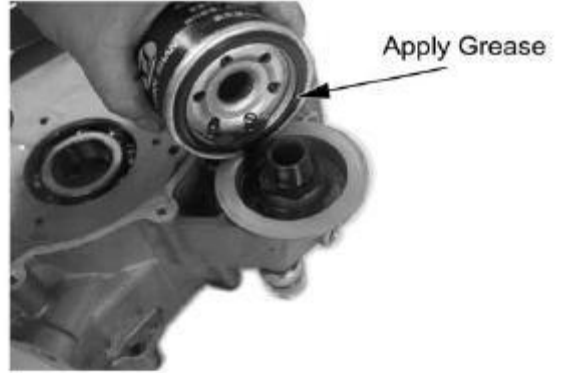

Starting Motor

Apply engine oil to new O-ring;

Install starting motor;

Install bolt and tighten to the specified torque

Tightening torque: 10N·m

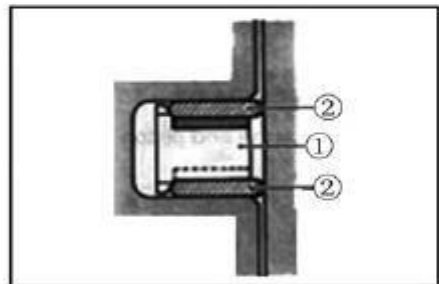

Engine Top Side

Piston

Install the piston rings in the order of oil ring, ②ring and ①ring.;

The first member to go into the oil ring groove is spacer①, after placing the spacer, fit the two side rails②.

Warning: when installing the spacer①, do not overlap its two ends in the groove.

Install the second ring A and first ring B

Note: 1st ring and 2nd ring differ in shape

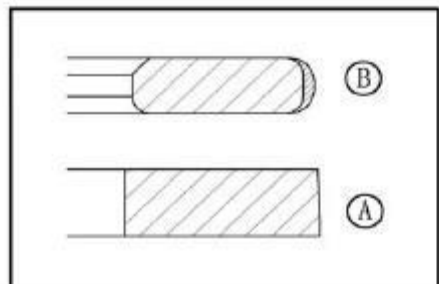
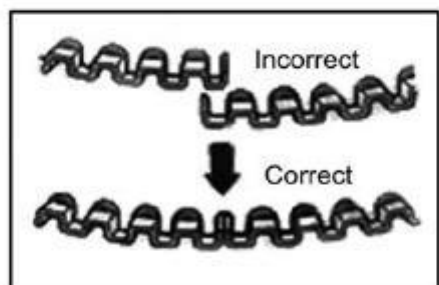

1st and 2nd rings have letter “R” marked on the side. Be sure to bring the marked side to the top when fitting them to the piston.

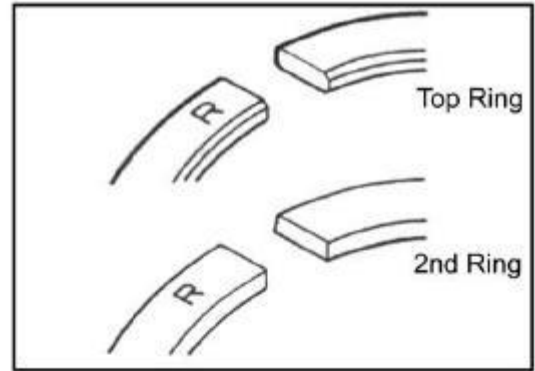

Position the gaps of the three rings as illustrated on the right. Before installing the piston into the cylinder, check that the gaps are so located.

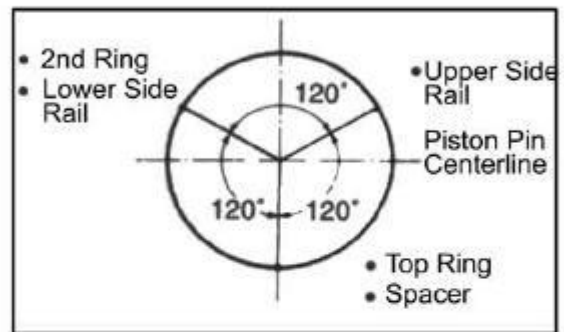

Apply a light coat of moly oil to the piston pin;

Install piston pin into holes of piston and conrod small end.



Note: When installing the piston, the “IN” mark on piston top is located to the intake side.

Place a clean rag beneath piston and install piston pin circlip ①

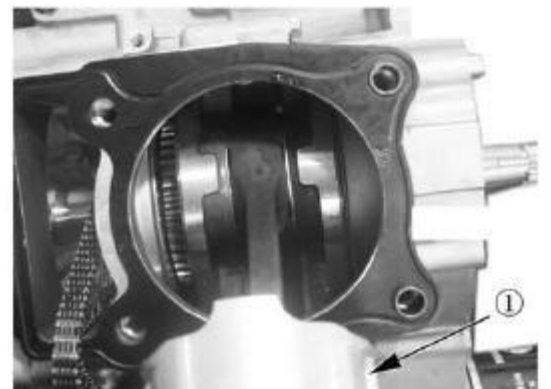

Note: while rotating crankshaft, pull the cam chain upward, or the chain will be caught between sprocket and crankcase.

Install the dowel pins and the new cylinder gasket;

Note: Use a new cylinder gasket to prevent oil leakage

Cylinder

Apply engine oil to piston skirt and cylinder wall;

Hold each piston ring with proper position, insert piston into the cylinder;

Tighten the cylinder base bolts temporarily;

Note: When installing the cylinder and cylinder head, pull the cam chain upward, or the chain will be caught between sprocket and crankcase.

Install chain guide①;

Fit the dowel pin and new cylinder cover gasket;

Note: Use a new cylinder cover gasket to prevent oil leakage

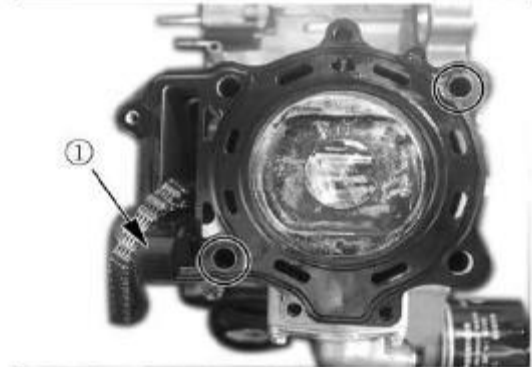
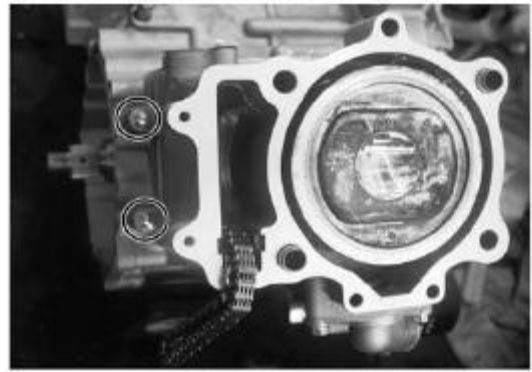

Cylinder Head

Install the cylinder cover, tighten the cylinder head bolts diagonally to the specified torque.

**Cylinder head bolt tightening torque: Initial: 25 N·m
Final: 40 N·m**

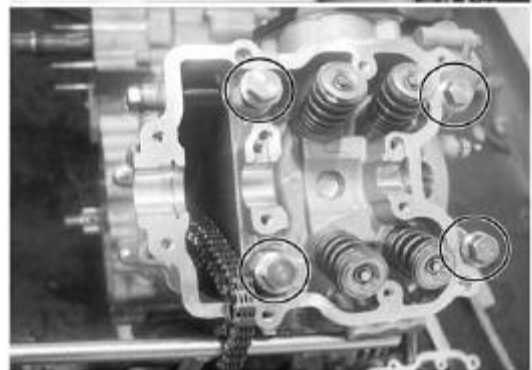

Tighten the cylinder head nuts to the specified torque;

Cylinder head nuts tightening torque:

M6: 10 N·m

M8: Initial 10 N·m

Final 25 N·m



Tighten the cylinder top nuts and cylinder base to the specified torque;

Tightening torque: 10 N·m



Install chain tensioner;

Camshaft

Align mark "A" on magneto rotor with mark "B" on crankcase;

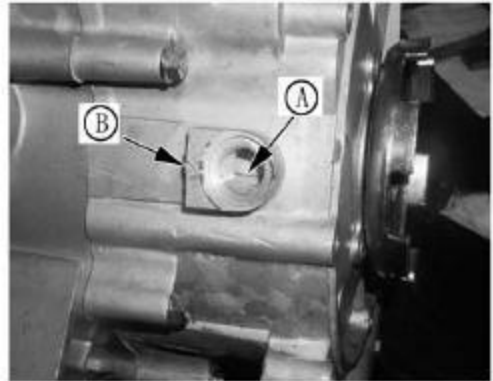

Note: while rotating crankshaft, pull the cam chain upward, or the chain will be caught between sprocket and crankcase.

Align the mark "A" on the camshaft so that they are parallel with the mating surface of the cylinder head.



Note: Do not rotate the magneto rotor while doing this. when the sprocket is not positioned correctly, turn the sprocket;

Engage the chain on the sprocket with the locating pin "B" as illustrated on the right;

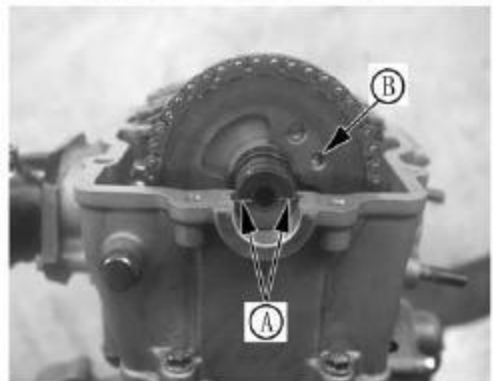

Recheck if the position of mark "A" and "C" is correct. If not, reassemble until it is correct.



Install crankshaft C-ring ①



Install lock washer so that it covers the locating pin;

Apply thread locker to the bolts before installing, and tighten them to the specified torque;

Sprocket bolt tightening torque: 15 N·m

Bend up the lock washer to lock the bolts.



Cylinder Head Cover

Clean the mating surface of cylinder head and cylinder head cover;

Install dowel pin to the cylinder head

Apply sealant to the mating surface of the cylinder head cover;

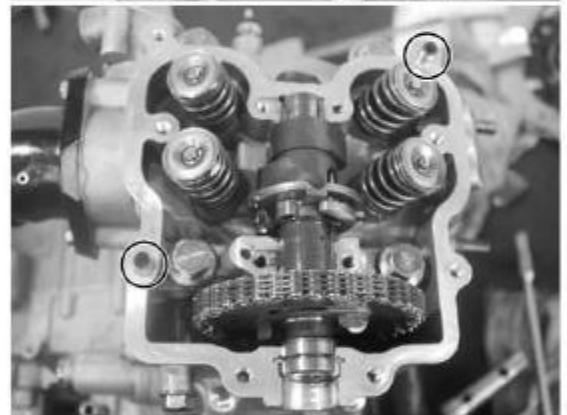

Install cylinder head cover bolts, tighten diagonally to the specified torque.

Cylinder head cover bolt tightening torque: 10 N·m

Note: When tightening the cylinder head cover bolts, the piston must be at top dead center on the compression stroke.



Gasket Sealant Applying Place

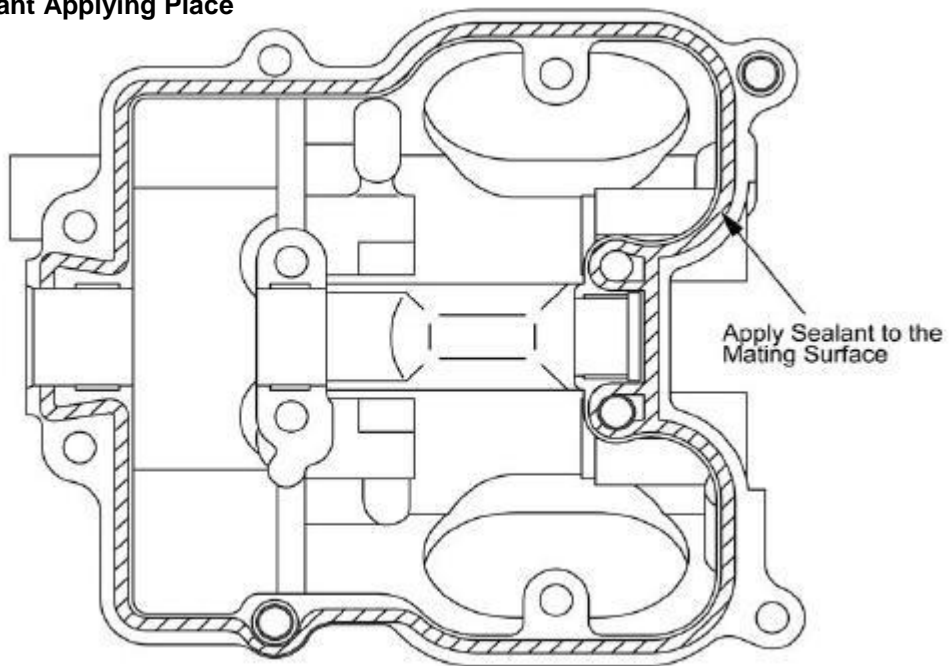

Chain Tensioner

Insert (--) screwdriver into slotted end of chain tensioner adjuster, turn it clockwise to lock the tensioner spring;

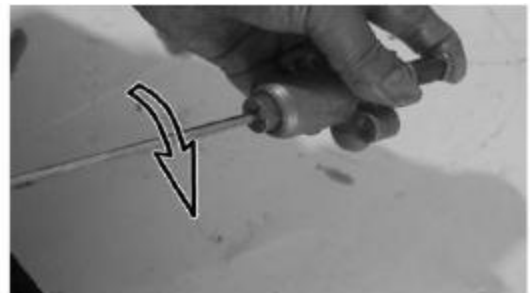

Install the chain tensioner and the new washer (1);

Install the bolt (2), tighten it to the specified torque;

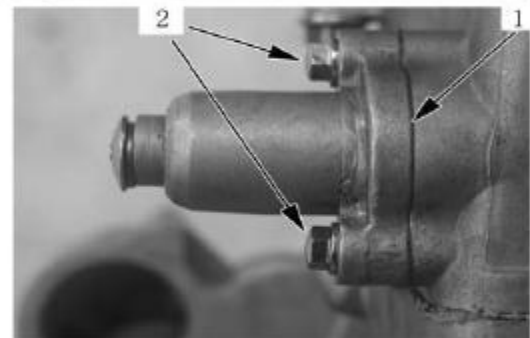

Chain tensioner bolt tightening torque: 10 N·m

After chain tensioner is installed, turn the (--) screwdriver counter clockwise. The tensioner rod will be advanced under spring force and push tensioner against chain.

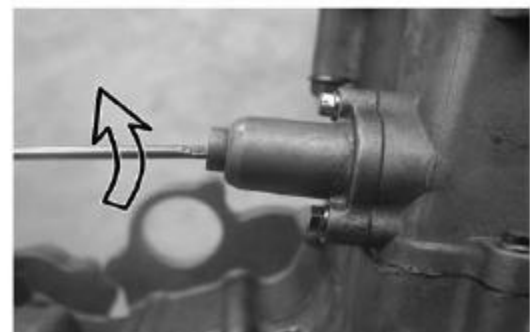

Install the new gasket (3);

Install chain tensioner screw, tighten it to the specifiedTorque

Chain tensioner screw tightening torque: 8 N·m

Valve Adjuster Cover

Use new rubber gasket and apply grease;

Install Valve Inspection Cap

Install valve inspection cap bolt;

Spark Plug

Install spark plug with special tool and tighten to the specified torque;

Note: To avoid damage to the cylinder head thread, screw in the spark plug with hand first, then tighten it to the specified torque with spark plug wrench.

Spark plug tightening torque: 18N·m
Tool: Spark Plug Wrench

Engine Periphery

Left Side Cover

Install left side cover

Install the bolts

Valve Inspection Cap

Install valve inspection cap

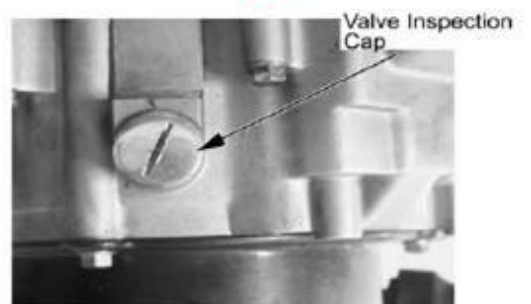
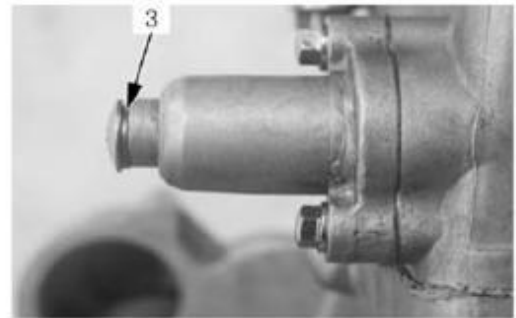

Water Pipe and Hose

Install water hose (5)

Install bolt (4)

Install water hose (3)

Install clamp (1) and (2)

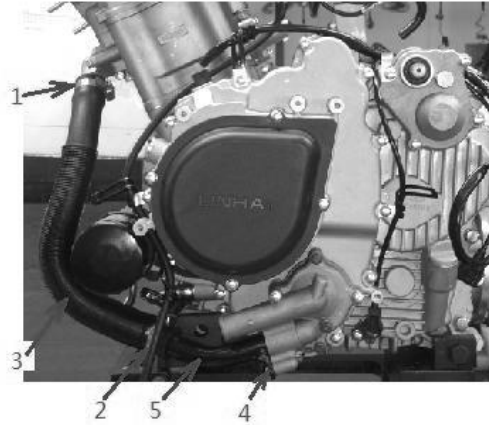

3.5. FUEL INJECTION SYSTEM

3.5.1 ECU

- 3.5.1.1 Description & Working Principle
- 3.5.1.2 Appearance
- 3.5.1.3 Handling – Don'ts & Do's
- 3.5.1.4 Installation requirements
- 3.5.1.5 Power Requirements
- 3.5.1.6 Temperature Requirements
- 3.5.1.7 Maintenance service and Repair

3.5.2 INJECTOR

- 3.5.2.1 Appearance
- 3.5.2.2 Temperature Requirements :
- 3.5.2.3 Fuel Contamination
- 3.5.2.4 Injector Installation
- 3.5.2.5 Replacement Techniques
- 3.5.2.6 Interchange ability
- 3.5.2.7 Cleaning Procedure

3.5.3 Throttle Body Assembly

- 3.5.3.1 Description and Working Principle
- 3.5.3.2 Appearance
- 3.5.3.3 Throttle Body Removal
- 3.5.3.4 Cleaning Procedure
- 3.5.3.5 Throttle Body Installation

3.5.4 Engine Coolant Temperature Sensor

- 3.5.4.1 Description and Working Principle
- 3.5.4.2 Appearance
- 3.5.4.3 Installation Requirements
- 3.5.4.4 Sample Cleaning

3.5.5 Intake Air Pressure and Temperature Sensor(MAP&MAT)

- 3.5.5.1 Description and Working Principle
- 3.5.5.2 Appearance
- 3.5.5.3 Operating Environment
- 3.5.5.4 Sample Cleaning

3.5.6 Oxygen Sensor

- 3.5.6.1 Description and Working Principle
- 3.5.6.2 Appearance
- 3.5.6.3 Technical Parameters
- 3.5.6.4 Fuel Quality Requirements

3.5.7 Ignition Coil

- 3.5.7.1 Description and Working Principle
- 3.5.7.2 Appearance
- 3.5.7.3 Installation requirements
- 3.5.7.4 DOs and DONTs

3.5.8 Fuel Pump Module

- 3.5.8.1 Description and Working Principle
- 3.5.8.2 Appearance
- 3.5.8.3 Operating Conditions
- 3.5.8.4 Service Procedure
- 3.5.8.5 Fuel Module Removal:
- 3.5.8.6 Fuel Module Installation:
- 3.5.8.7 Fuel Pressure Relief Procedure:
- 3.5.8.8 Fuel Leakage Check Procedure:

3.5.9 Motor Scanner (for MT05.3 EMS)

- 3.5.9.1 Precautions
- 3.5.9.2 Configurations
- 3.5.9.3 Preparations Connection
- 3.5.9.4 Functions
- 3.5.9.5 MT05.3 ECU Malf Code

3.5.1 ECU

3.5.1.1 Description & Working Principle

The ECU continuously monitors the operating conditions of the engine through the system sensors. It also provides the necessary computation, adaptability, and output control in order to minimize the tailpipe emissions and fuel consumption, while optimizing vehicle drivability for all operating conditions. The ECU also provides diagnosis when system malfunctions occur.

3.5.1.2 Appearance

The MT05.3 ECU has a polyester header, with an aluminum base plate. The ECU is shown below.



3.5.1.3 Handling –Don’ts & Do’s

ACTION	REASON
DO NOT: Place the ECU close to the exhaust pipe or Engine when removed.	High temperature might reduce the life of the ECU and also can damage the ECU.
DO NOT: Place the ECU close to or pour water, oil or any other liquids.	ECU is susceptible to water and liquids
DO NOT: Allow mud or other debris to accumulate on the surface of the ECU.	Having mud or debris accumulated on the ECU casing reduces its heat dissipation efficiency.
DO NOT: Apply any voltage relative to any point to the ECU.	Drastically affects the performance of the ECU and may lead to ECU damage.
DO NOT: Clean ECU with any solvent or any corrosive liquid.	Can damage the housing of the ECU.
DO: Take extreme care that water droplets or excess moisture should not fall on ECU connectors.	ECU connectors can get short and may lead to ECU damage.
DO: Clean the ECU with a moist cloth and keep it dry.	Prevents ECU damage.

3.5.1.4 Installation requirements

The ECU shall be mounted using M6 machined screws with a torque of 8 Nm ±10%. The mounting surface should also be flat to avoid subjecting the base plate to unnecessary force and warping the PCB.

3.5.1.5 Power Requirements

- **Operating Range:** All planned functions are executed in this range. Battery and/or Ignition voltage: 9.0 to 16V DC. However, when the battery voltage is lower than 13.6 volts, the engine’s start speed may be low. Then, you should charger the battery with the charge.
- **Reverse Voltage:** The controller will survive with no permanent damage: Battery and/or Ignition voltage < -13V DC for 1 minute. But the fuse will fuse.

3.5.1.6 Operating Temperature

The controller shall operate in the ambient temperature from -20 °C to +85 °C.

3.5.1.7 Maintenance service and Repair

ECU is a non-serviceable part. Once there are problems, it’s important to first determine if the problem is caused by software/calibration. If it is caused by software/calibration, please reflash the ECU by professional tools. In the event of ECU hardware failure or malfunction (during warranty period only) the ECU should be sent back to the vehicle manufacturer giving complete details of the ECU Part No, Serial number, Vehicle Model & Make, manufacturing Date, Total kms run on the vehicle, Location of use, Vehicle No, Date of return.

3.5.2 INJECTOR

3.5.2.1 Appearance

The figure below shows the standard M3.5 Fuel Injector appearance.

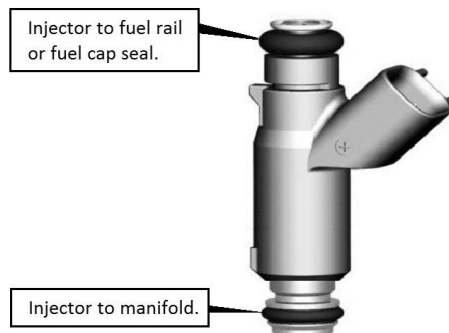

3.5.2.2 Temperature Requirements :

Typical injector temperature environments are defined below. The injector will not experience any loss of the ability to comply with the flow tolerance requirements after exposure to the following temperature environments. Also, they will not experience unacceptable external leakage, any type of physical degradation, or loss of service life during or after being exposed to these ambient conditions.

- Normal Operating Temperature Range: - 30°C to 125°C
- Extreme Operating Temperature Range (some performance degradation): - 40°C to 150°C

3.5.2.3 Fuel Contamination

The injector fuel inlet filter protects the fuel injector from initial build fuel contamination as well as from fuel system assembly contamination. Filtration is extremely important because particle contaminants can cause an injector to stick open, flow shift or tip leak.

The injector inlet filter is not a serviceable component and is designed only to trap potential built-in contamination between the chassis fuel filter and injector.

Please replace the fuel filter regularly according to the usage. The filter is located above the

tank.



Filter

3.5.2.4 Injector Installation

Follow these guidelines to prevent damage to the injector and its electrical interface during the replacement or re-installation process.

- Lubrication: Apply a light coating of lubricant to the lower injector seal ring. ISO 10 light mineral oil or equivalent is recommended.
- The preferred technique is to apply the lubricant to the sockets the injectors are being installed into, rather than directly to the seal ring itself. This will help minimize the possibility of injector contamination.
- Avoid applying lubricant over the director plate holes – this may restrict injector flow. Do not dip the injector tip in lubricant.
- The injectors come from the factory with the seal rings attached. The re-use of seal rings is not preferred when replacing an injector. If an injector is to be re-used, and no new seal rings are available, take care to inspect each seal ring for signs of damage. Even minor defects in the seal ring can lead to leakage. Take extra care in installing seal ring over flange of injector inlet.
- Carefully installing the harness connector will prevent terminal damage. Listen for a positive audible click from the connector retention device — this ensures that it is fully engaged.
- Avoid unnecessarily disconnecting/reconnecting the harness connector.
- Wires routed in a manner that can allow them to become pinched between components can result in a short circuit and a stuck open injector.
- For injectors that require orientation for spray pattern, do not rotate the injector in the fuel rail assembly to install the injector electrical connector. This may dislodge the retaining clip, and result in improper spray orientation.

The table is a list of lubricant oils that were tested and approved for O-ring lubrication. These lubricants have shown to have no effect on injector performance (plugging, sticking).

Lubrication Recommendation		Table: 6
Lubricant Name	Supplier	Viscosity (cSt) @ 40 °C
Spindura 10	Equilon	10
Spindura 22	Equilon	21
DTE-24	Mobil	32
DTE-25	Mobil	46
DTE-26	Mobil	68
Norpar 15	Exxon / Mobil	<1
Drawsol 60	DA Stewart	1-2
NocoLube AW 46	NOCO Energy	46
NocoLube AW 32	NOCO Energy	32
Advantage Spindle Oil	Advantage Lubrication Specialties	10

3.5.2.5 Replacement Techniques

The following procedure outlines standard the Injector removal and replacement.

Warning: The injector and all associated hardware may be extremely hot.

- Shut off ignition.
- Disconnect negative battery cable to avoid possible fuel discharge if an accidental attempt is made to start the engine.
- Disconnect the electrical connector from the injector wiring harness.
- Relieve fuel pressure
- Remove the retaining clip from the fuel injector.
- Remove the fuel line connection from the injector
- Carefully clean debris from the interface surfaces. Do not damage seal mating surfaces.
- Remove the injector from the manifold.
- Apply a light coating of a lubricant to both the upper and lower injector seal ring of the replacement injector.
- Install the new injector into the manifold. Check that the injector is installed in the original orientation to maintain proper spray targeting, and that the retaining clip is properly seated on the injector and the fuel line.
- Install the retaining clip after connecting the fuel line.
- Tighten the injector mounting to the desired torque as mentioned in the manufacturer manual.
- Tighten the fuel line.
- Re-install the injector electrical connector
- Check for fuel leaks with the key “on” and the engine “off”.
- Start engine and verify proper operation.

3.5.2.6 Interchange ability

The injector should be replaced in service only with an equivalent injector of the same part number. On occasion, a new part number may supersede part numbers. Consult the appropriate vehicle service manual and part number guide for the latest replacement injector part number information.

3.5.2.7 Cleaning Procedure

- Electrically disable the fuel pump by removing the fuel pump connection.
- Relieve the fuel pressure in the system and disconnect the fuel connection at the injector. Plug the fuel feed line.

- Injector cleaner with the specific ratio of the cleaner and gasoline to be mixed in the Injector cleaning tank.
- Connect the injector-cleaning tank to injector in the vehicle.
- Pressurize the injector-cleaning tank to system pressure.
- Start and idle the engine for 15- 20 minutes.
- Disconnect the injector-cleaning tank from the system and install the fuel pump connections. Connect the fuel feed line to injector.
- Start and idle the vehicle for an additional 2 minutes to ensure the residual injector cleaner is flushed from system.

3.5.3 Throttle Body Assembly

3.5.3.1 Description and Working Principle

The Throttle Body Assembly is an interactive system comprised of the following subsystems: the main casting body, bearing system, shaft and valve system, return spring system, cable interface system, throttle position sensing system, and the bypass air control system. The subsystems interact and support each other to provide all the functional requirements, which are mentioned below:

- Control intake air flow
- Control idle air flow
- Sense throttle position - Provide position feedback to Engine Controller
- Provide reactionary force to the throttle

3.5.3.2 Appearance

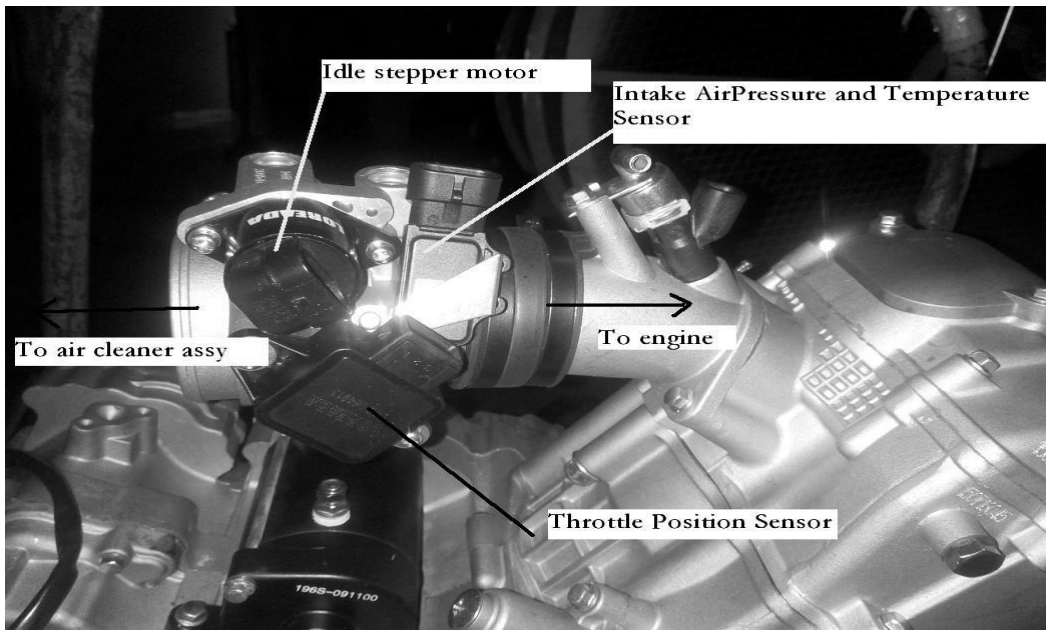

3.5.3.3 Throttle Body Removal

- Disconnect negative terminal of the battery
- Disconnect electric lead wire of throttle position sensor coupler, stepper motor coupler and MAP/MAT sensor coupler (if this sensor is mounted on the throttle body)
- Disconnect accelerator cable from throttle body
- Remove air cleaner outlet hose and throttle body outlet hose

3.5.3.4 Cleaning Procedure

If there is cover on the bottom, it may be removed and cleaned using carburetor cleaner (3M make recommended). Once the throttle body cover is removed, spray the throttle-body cleaner inside the shipping air passage, and use the brushes to gently dislodge the dirt, gum and varnish that are present. Do not let the by pass holes be blocked by dirt or foreign particles.

3.5.3.4 Throttle Body Installation

Reverse the procedure for installation noting the following:

- Adjust accelerator cable play.
- Check to ensure that all removed parts are back in place.
- Reinstall any necessary part which have not been reinstalled.

3.5.4 Engine Coolant Temperature Sensor

3.5.4.1 Description and Working Principle

This sensor is used in water cooled engines. It provides a resistance that varies as a function of temperature within prescribed tolerance limits. The sensor has a negative temperature coefficient of resistance.

3.5.4.2 Appearance



3.5.4.3 Installation Requirements

Dynamic Torque Requirement: The sensor shall be hand into the application and then driven by a driver with a maximum no load speed of 400 rpm or installed to the desired torque by a hand torque wrench (5/8" hex). The recommended installation torque is:

- Minimum: 20 N·m
- Maximum: 25 N·m
- Static Torque Requirement: The torque required to remove the sensor from the mating hole shall be within 200% of the installation torque mentioned above.

3.5.4.4 Sample Cleaning

When necessary the samples may be cleaned in isopropyl alcohol for one minute with mating connectors in place and then air-dried.

3.5.5 Intake Air Pressure and Temperature Sensor(MAP&MAT)

3.5.5.1 Description and Working Principle

This sensor has two functions. The first is the intake manifold air temperature, it provides a resistance that varies as a function of temperature within prescribed tolerance limits. The second

is the intake manifold air pressure; it provides a voltage varies as the intake air pressure. This sensor is installed on the Throttle Body Assembly.

3.5.5.2 Appearance



3.5.5.3 Operating Environment

This device is intended for use in inlet manifold for sensing air temperature and pressure which shall withstand such an under hood environment.

- Pressure Range: 20~102kPa
- Temperature Range: -40~105°C
- Relative Humidity: 0 to 100% RH.
- Typical Voltage: The sensor circuit operates with a DC voltage reference of 5 ± 0.1 VDC.

3.5.5.4 Sample Cleaning

When necessary the samples may be cleaned in isopropyl alcohol or gasoline for one minute with mating connectors in place and then air-dried.

3.5.6 Oxygen Sensor

3.5.6.1 Description and Working Principle

This sensor is a device for monitoring the residual oxygen in the exhaust of an internal combustion engine. It is the feedback element for engine closed loop control.

3.5.6.2 Appearance



3.5.6.3 Technical Parameters

- A/F ratio rich threshold: >750 mVDC
 - A/F ratio lean threshold: <120 mVDC
- (These parameters as above are measured basing on 450°C (engine dyno), typically on 70% duty at 10Hz and under 13.5V)
- Heater part resistance: $9.6 \pm 1.5 \Omega$ (This parameter is measured basing on 21°C)
 - Operating temperature range: 260-850 °C

3.5.6.4 Fuel Quality Requirements

- Pb≤0.005g/L
- P≤0.0002g/L
- S≤0.04% (weight proportion)x
- MMT≤0.0085g/L
- Si≤4ppm

3.5.7 Ignition Coil

3.5.7.1 Description and Working Principle

This coil provides energy to the spark plug in the combustion chamber. The coil itself doesn't have a driver. The high voltage tower of the coil is connected to the spark plug using a high voltage cable assembly.

3.5.7.2 Appearance



3.5.7.3 Installation requirements

- The vehicle frame provides the mounting surface and mounting holes.
- Mount coil close to the spark plug and keep the plug wire length very short (less than 6 “).
- Mount coil away from any pick coil device. Especially, a VR type Crank / Cam sensor. Keep a Min distance of 150 mm (around 6”) between coil and any VR sensor device.
- Never route the coil C- wire with the same bundle as the Crank sensor wires. There is around 200 V peak potential between C- wire and engine ground. This voltage potential could cause a noise on sensor cables.

3.5.7.4 DOs and DONTs

ACTION	REASON
DO NOT: Install the low voltage connectors with the power applied.	This might cause an unwanted secondary firing, possibly leading to personal injury.
DO NOT: Use a screw driver to asset in removing secondary boots from the secondary tower. Use tools designed for secondary removal.	It is possible to damage a secondary lead in such a manner that creates an electrical path to outside the system permitting improper system operation misfire, or even possible personal injury if arcing occurs.
DO NOT: Use parts that have been dropped or display physical damage.	Damaged components can lead to premature failure.
DO NOT: Scratch or apply any non approved material to the surface of the high voltage tower which mates with the high voltage secondary leads.	This can jeopardize the seal integrity of the mating surfaces which in turn can create a secondary high voltage leak path.

DO NOT: Strike any part of the ignition system with a tool or other object.	This can lead to physical damage which can cause a system malfunction or failure.
DO NOT: Permit paint or other sprayed materials to be sprayed onto the electrical connectors.	Insulating type sprays can create a high resistance or open connection. And, a conductive type spray can create an electrical short condition.
DO NOT: Support the ignition system by the wiring harness or plug wire.	These leads are not designed to support the weight of the ignition system. It can create a poor electrical connection Or become disconnected allowing the system to fall and be subjected to physical damage
DO NOT: Pierce or probe the secondary leads.	This creates an electrical path to outside the system permitting improper system operation, misfire, or even possible personal injury if arcing occurs.
DO NOT: Operate without the spark plug attached.	If a technician or mechanic comes in contact with the high voltage generated during operation, personal injury may occur. Or, if the engine is operated under this condition, unburned fuel may fill the converter area creating a potential hazard.
DO NOT: Share ignition component wiring with other components, Dedicated wiring is required.	This prevents electrical cross talking between components which can lead to component malfunction.
DO NOT: Apply voltage to the ignition system other than vehicle system voltage for testing purposes.	This can cause reduced performance or an electrical malfunction of the ignition system
DO NOT: Use high impact tools to apply the spark plug boot to the ignition secondary towers. Installation of the high voltage secondary leads by hand is preferred.	Damage to the coil tower, secondary boot, or mating connection surfaces might occur.
DO: Install the secondary leads before connecting the primary leads.	In the event the low voltage connection has been made and the power applied, unwanted secondary output might occur possibly resulting in injury, damage the ignition component, and test equipment.
DO: Take care when working around the ignition system.	The high voltage produced by the coil secondary circuit can cause personal injury and/or damage test equipment.
DO: Proper handling and shipping methods need to be in place to reduce the risk of damage due to impact, moisture, or contamination.	Damaged components can lead to premature failure.
DO: Avoid unnecessary disconnecting and connecting of the electrical components.	The electrical connections are not designed for repeated connection and disconnection.
DO: Insure the low voltage connectors are entirely seated and the locking mechanism is engaged.	This prevents intermittent electrical connections leading to an improper ignition system operation.
DO: Use approved connector breakouts when testing the ignition system.	Connector and/or component damage may occur.
DO: Insure the appropriate seals are included in the connector system.	Liquid intrusion into the terminal connection area might occur causing an electrical intermittent or short condition. In the event of severe terminal corrosion, an open condition might occur.
DO: Operate with gasoline based internal combustion engines.	Other fuels or combustion designs may require additional design considerations.
DO: The power feed line should be fused.	This could protect the system in the event of an electrical short.
DO: The module heat sink and back plate must not be used as a connection point when jump starting	The high level of voltage and current which the module could be subjected to, could cause module

the engine.	performance degradation or failure.
DO: Connection of the module back plate to vehicle ground is desirable whenever possible.	This greatly reduce potential ground loops and acts as a heat transfer source from the module.
DO: The ignition system ground wire should be kept as short as possible. And, when permissible, should be grounded at the same engine block position as the engine controller.	This would greatly reduce the possible of unwanted electrical ground loops.
DO: The electrical wiring to the ignition system should be routed so that the conductors are protected from excessive heat, damage, and wear.	Helps prevent electrical intermittent, open or shorted operating conditions.
DO: Ignition secondary leads should not be routed with the ignition primary harness or any other electrical harness.	Voltage spikes can be transmitted from the secondary cables into other leads which are in close. This could create a component performance degradation or failure condition.
DO: Spark plug wires(secondary leads) & primary wiring: <ul style="list-style-type: none"> - must not contact sharp surface. - must not be under tension between fixed points. - must be clear of moving parts (belts, fan, etc...). - must be protected from or kept at least 125 mm away from radiant heat source exceeding 400 F. - must be protected from environmental damage (dirt, splash, oils, fluids, etc...). - must be retained, secured or insulated to prevent pinching, mis-routing, rattles, and squeaks. 	<ul style="list-style-type: none"> - Spark plug wires carry very high voltage (30,000 volt). If the secondary lead loses its dielectric characteristics thru being nicked, cut , chaffed, then an arc thru to a near by ground could take place. This kind of condition could lead to misfire, no start, or premature failure of ignition system.
DO: Not all fasteners are designed for repeat use. Beware of fastener specifications. All harnesses should be supported within 6" of a mating connection.	Adequate retention force might not be achieved if the fastener is not designed to be reused. Mating connections are not designed to support the weight of the harness assembly.
DO: For removing spark plugs follow the following steps: 1- Grasp the spark plug boot and gently rotate 90° ; and then pull the spark plug boot and cable away from the spark plug. 2- Before removing spark plug, brush or air blast dirt away from the well areas. 3- Use correct size deep socket wrench to loosen each spark plug one or two turns.	To remove spark plugs from Aluminum heads, allow the engine to cool. The heat of the engine, in combination with a spark plug that is still hot, may cause the spark plug threads to strip the cylinder head upon removal. Use goggles to protect eyes from dirt when applying compressed air to spark plug wells.
DO: Cleaning a spark plug could be done as follow: 1- wipe all spark plug surfaces clean....remove oil, water, dirt and moist residues. 2- If the firing end of spark plug has oily or wet deposit, brush the spark plug in an approved, non-flammable and non-toxic solvent. Then dry the spark plug thoroughly with compressed air. 3- Use a propane torch to dry wet-fuel fouled plugs. Allow the torch flame to enter up the center electrode insulator. Allow plug to cool down. 4- If the spark plug threads have carbon & scale deposits, clean with wire brush, taking care not to injure the electrode or the insulator tip.	<ul style="list-style-type: none"> - Cleaning a spark plug will reduce the voltage required for an electrical arc(spark) across the electrodes. - Cleaning & re-gapping will not restore a used spark plug to a new condition. It may be more economical and efficient to replace used spark plugs with new plugs instead of cleaning. - Sooted plugs should be replaced. - Do not cool by using water or any liquid. - Clean threads permit easier installation and proper seating which will maximize transfer heat away from the plug.
DO: Regap spark plugs to the exact measurement	- Too wide a gap could cause the plug to

<p>specified by the engine manufacturer to keep the best fuel economy and proper engine performance:</p> <ul style="list-style-type: none"> - Use round wire-type gauge for an accurate measure of gap on all used spark plugs. - when gapping a spark plug only the side electrode is moved. The center electrode must not be moved. 	<p>misfire(higher required ignition voltage).</p> <ul style="list-style-type: none"> - Too narrow of a gap could affect idle stability. - A flat gauge can't accurately measure the spark plug on used plugs.
<p>DO: When replacing spark plugs with new ones, always use equivalent plugs with same heat range, thread, size, etc....</p>	<ul style="list-style-type: none"> - Higher heat range plug(hotter plug) could lead to pre-ignition & possible piston damage. - Lower heat range (colder plug) could lead to cold fouling & emission problem.
<p>DO: For installing spark plugs follow the following steps:</p> <ol style="list-style-type: none"> 1- make sure the cylinder head threads and spark plug threads are clean. Make sure the spark plug thread is free of dings and burrs. If necessary, use a thread chaser and seat cleaning tool. 2- Make sure the spark plug gasket seat is clean, then thread the gasket to fit flush against the gasket seat. Tapered seat plugs do not require gaskets 3- Screw the spark plugs finger-tight into the cylinder head. Then, use a torque wrench to tighten spark plugs following manufacturer's recommendation. <p>Torque is different for various plug type & cylinder head material.</p>	<ul style="list-style-type: none"> - If the thread is damage, it prevents a good heat transform from the shell to the cylinder head. - Do not use any type of anti-seize compound on spark plug threads. Doing this will decrease the amount of friction between the threads. The result of the lowered friction is that when the spark plug is torqued to the proper specification, the spark plug is turned too far into the cylinder head. This increases the likelihood of pulling or stripping the threads in the cylinder head. - Over-tightening of a spark plug can cause stretching of the spark plug shell and could allow blowby to pass thru the gasket seal between the shell and insulator. Over-tightening also results in extremely difficult removal.

3.5.8 Fuel Pump Module

3.5.8.1 Description and Working Principle

Fuel Pump Module supplies fuel to engine at system pressure. Fuel Pump Module is mounted to fuel tank at top and supplies fuel to engine through hoses. Fuel Pump module consists of Fuel Pump to generate the fuel flow and pressure regulator to regulate the fuel pressure.

When power is supplied to fuel pump, motor in pump assembly rotates the impeller. Impeller in turn draws the fuel from strainer and pumps the flow to generate the system pressure.

Pressure Regulator is a diaphragm type mechanical device. Fuel flow from filter enters in the inlet of pressure regulator. Pressure regulator regulates the fuel pressure at a set pressure by releasing the excessive fuel flow to fuel tank.

3.5.8.2 Appearance

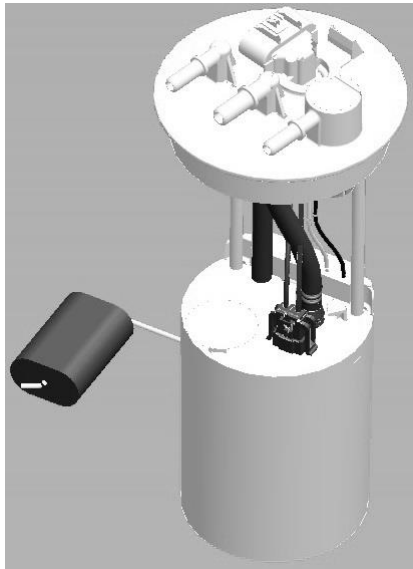

3.5.8.3 Operating Conditions

- Fuel Pump Module needs to be mounted on Fuel Tank Top according to the installation instructions.
- Fuel Pump Module is intended to use with gasoline. However if the fuel contains ethanol, please contact vehicle manufacture to check whether the fuel pump module itself can survive or not.
- Make sure there is at least 3 liters of gasoline in the fuel tank before priming for first time (do not run the pump dry).

3.5.8.4 Service Procedure

Precautions:

Before attempting any service on fuel system, following cautions should be always followed for personal safety and to avoid system damages.

- Disconnect negative cable at battery.
- DO NOT smoke, and place ‘No SMOKING’ sign near work area.
- Make sure to have fire extinguisher handy.
- Make sure to perform work in well ventilated area and away from any open fire/flames.
- Wear Safety glasses.
- To relieve fuel vapor pressure in fuel tank, remove fuel filler cap fuel filler neck and then reinstall it.
- As fuel lines are at high pressures when the engine is stopped, loosening or disconnecting fuel line will cause dangerous spout of fuel. Before loosening/ disconnecting fuel lines, please follow the ‘Fuel Pressure Relief Procedure’ described in this section.
- Small amount of fuel may drip after the fuel lines are disconnected. In order to reduce the risk of personal injury, cover the pipe/ hose ends with suitable blind with no rust or contamination.
- After servicing, make sure that the fuel hoses and clamps are connected according to the hose fitment instructions given in vehicle instruction manual.
- After servicing, please follow the ‘Fuel Leakage Check Procedure’ described in this section.
- After servicing make sure to fill at least 3 liters gasoline before pump is primed (ignition key should be turned on only after ensuring there is minimum 3 liters of fuel in the fuel tank)

Fuel Module Diagnosis:

Step	Action	Yes	No
1	Switch on Ignition key. Fuel Pump primes for 3 seconds when the ignition key is ON. Check for fuel pump running noise for 3 seconds after ignition key is ON.	If fuel pump running noise can be heard, go to step 4.	If fuel pump running noise can not be heard, go to step 2.
2	Disconnect fuel module coupler. Check voltage at harness coupler. Is the voltage within 10-14V?	Go to step 3	Check the electrical circuit from Ignition to fuel module.
3	Connect 12V DC power supply (battery) to fuel module. Make sure that enough fuel available in fuel tank to avoid fuel pump running dry. Is the fuel pump running?	1. Check electrical circuit from fuel module to ECU. 2. Check ECU.	1. Check Fuel Pump Harness integrity. 2. Check Fuel Pump.
4	Check fuel system pressure at Injector inlet (with a T-joint) while engine is running in idle condition. Is the pressure about 300 kPa?	Fuel Module Operation Normal	Go to Step 5
5	Is the Pressure below 300kPa too much?	1. Check for leakages from hoses, hose joints 2. Check Fuel Pump 3. Check Pressure Regulator	1. Clogged Filter 2. Kink/ Blockage in Fuel Hoses 3. Check Re

3.5.8.5 Fuel Module Removal

- Relieve fuel pressure in fuel lines referring to the **'Fuel Pressure Relief Procedure' (3.5.8.7)** provided in this section.
- Disconnect negative cable at battery.
- Disconnect fuel module wire coupler.

- Drain the fuel in fuel tank thru fuel filler with help of hand pump (siphon). Collect the fuel in approved container for contamination and safety.
- Disconnect the fuel hoses from fuel module by using standard tools
- Remove the fuel tank from vehicle.
- Place the fuel tank with bottom up condition. Care to be taken not to cause any scratches/damages on fuel tank.
- Open the fuel module mounting bolts.
- Take out fuel module assembly from fuel tank with care
- Care to be taken not to damage the strainer while removing fuel module from tank.

3.5.8.6 Fuel Module Installation

- Replace the fuel module gasket in fuel module assembly with a new one. Old/ used gaskets can cause leakages.
- Fold strainer towards fuel pump and insert fuel module in tank opening with care. Care should be taken not to cause any damages on strainer. Make sure that the fuel tank surface at module mounting area is clean and free of surface defects.

- Place the bolts on module cover and tighten the bolts gradually in star pattern sequence to apply equal compression on gasket. It is shown as below:

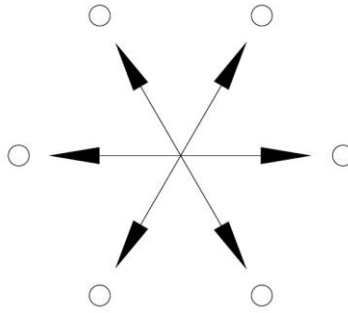

Bolt Tightening Torque: 10 Nm. Fuel module is installed with the M6×10 bolts. Use designated bolts only. Follow the tightening torque and tightening sequence instruction. Over torque and miss-sequence can cause unequal compression of gasket and leakage.

- Install the fuel tank to vehicle.
- Connect for fuel hoses with suitable hose clamps.
- Connect fuel module coupler
- Follow ‘ **Fuel Leakage Check Procedure**’ (3.5.8.7) to check any leakage before the engine is started.

3.5.8.7 Fuel Pressure Relief Procedure

Caution: This work must not be done when engine is hot. If done so, it may cause adverse effect to catalyst (if equipped)

After making sure that engine is cold, relieve fuel pressure as follows.

- Place vehicle gear in ‘Neutral’.
- Disconnect fuel module electrical coupler from vehicle harness.
- Start engine and run till it stops due to lack of fuel. Repeat ignition key ON and OFF for 2 ~ 3 times of about 3 seconds each time to relieve fuel pressure in lines. Fuel Connections are now safe for servicing.
- Upon the completion of servicing, Connect Fuel Module Connector to Vehicle Harness.

3.5.8.8 Fuel Leakage Check Procedure:

After performing any service on fuel system, check to make sure that there are no fuel leakages as below.

- Fill about 3 ~ 5 liters of fuel in tank.
- Turn Ignition key to ON position for 3 seconds (to operate fuel pump) and then turn to OFF position. Repeat this for 3 ~ 4 times to apply fuel pressure in fuel lines.
- In this state, check to see that there are no fuel leakage from any part of fuel system (Fuel Tank, Hoses, Hose Joints, etc)

3.5.9 Diagnostic Tools(Motor Scannerfor MT05.3)



1	[←] Key	To return to the previous interface
2	[▲] Key	To move the cursor to upper item in the menu
3	[▼] Key	To move the cursor to down item in the menu
4	[◀] Key	To move the cursor to left item in the menu
5	[▶] Key	To move the cursor to right item in the menu
6	[↵] Key	To confirm and execute this operation

3.5.9.1 Precautions

- Motor-Scanner is a precision instrument and should be protected from vibration and impact.
- If the unit does not run correctly or the screen is unstable when first turned on, disconnect it from the main lead and try again.
- Make sure the DLC is always firmly inserted into the diagnostic socket.
- Never test electrical signals that exceed the limit of specifications.
- Test cannot be performed by the person who is driving the car.
- This unit should be used and stored in the following conditions:
 Ambient temperature: 0~50℃
 Relative humidity: <90%

3.5.9.2 Configurations

- Find the 6PIN diagnostic socket on the vehicle.
- Connect one end of the diagnostic main cable to the diagnostic socket on the vehicle. Turn on the key.

When power is on normally, the unit will display: ➡

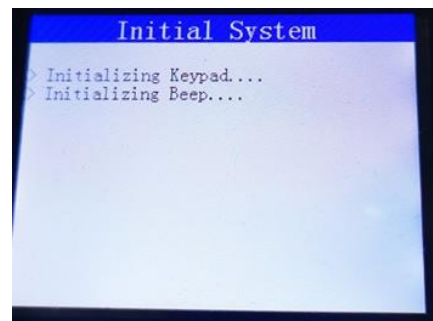

Seconds later, the unit will display: ➡

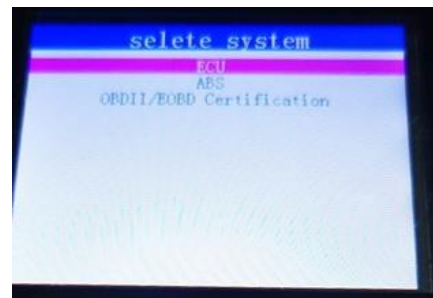

3.5.9.3 Functions

Motor-Scanner can be used to diagnose Engine Management System with functions: Read DTC, Clear DTC, Data Stream, Status Stream, and Record Data.

Operations

When the unit is powered up, the screen will display the interface as right.

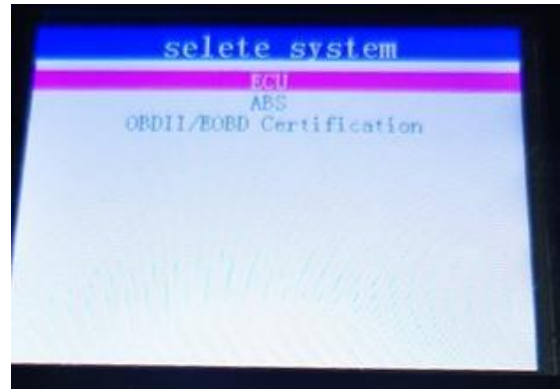

Here, we take diagnostic function for demonstration.

Select ECU and press [↵] key, it will display an interface for EFI system selection, as shown right.

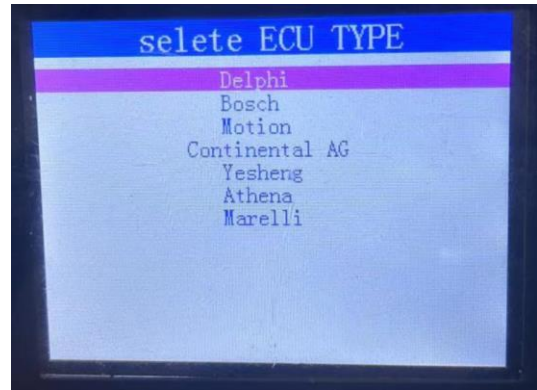

Select 'Delphi' and press [↵] key, it will display information about the ECU version list, as shown right

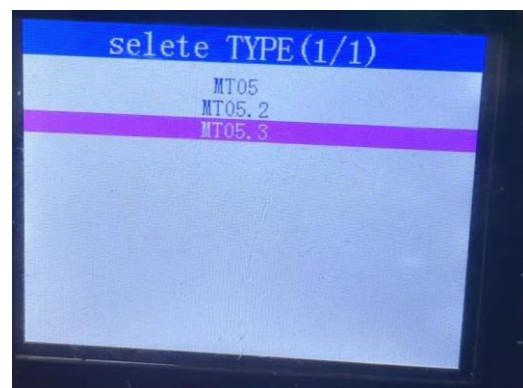

Select 'MT05.3' and press [↵] key, it will display information about function list, as shown right



Available functions are as follows:

- Read DTC
- Clear DTC
- Data Stream
- Record Data

Press ▲ or ▼ or ◀ or ▶ key to select function you needed, as shown right



1. Read DTC

Select 'Read DTC' , and press [↵], it will display function list as right.

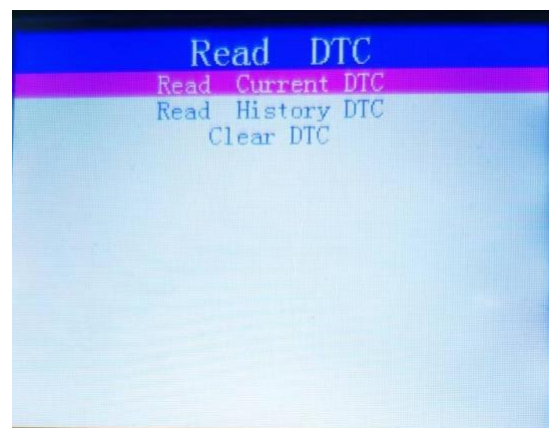

Select 'Read Current DTC' and press [↵],
 If there are some malfunctions with the
 vehicle's EFI system, the screen will display
 fault information as right

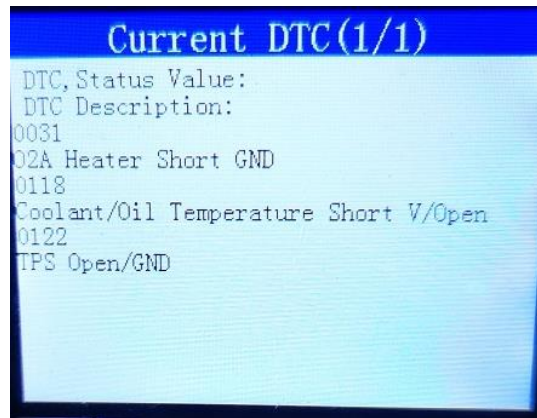

2. Clear DTC

Select 'Read DTC' , and press
 [↵], it will display function list as right.

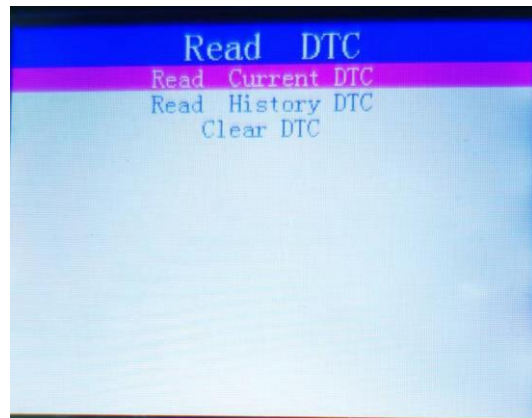

Press ▼ key to select 'Clear DTC' and
 press [↵], the screen will display
 "SUCCESS", as shown right.
 This means the fault code has been
 removed successfully.

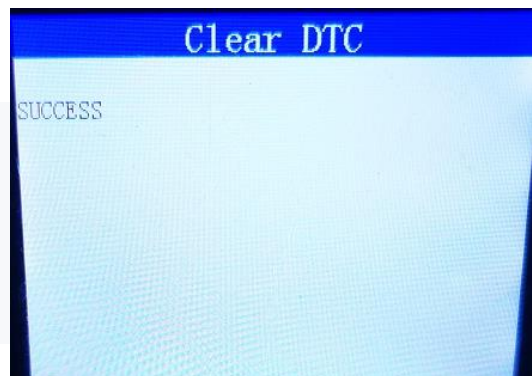

3. Data Stream

Select 'Read Date'  , and press [↵] → it will display function list as right.

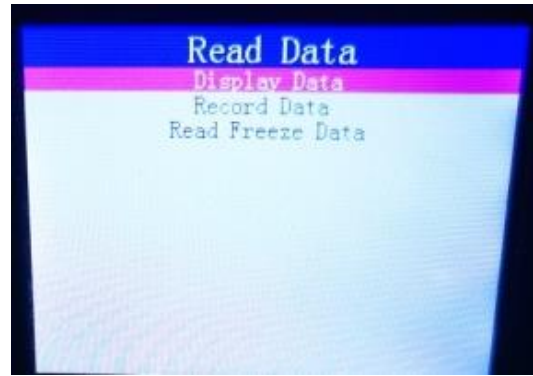

Select 'Display Date' , and press [↵] , it will display Engine information as right . →

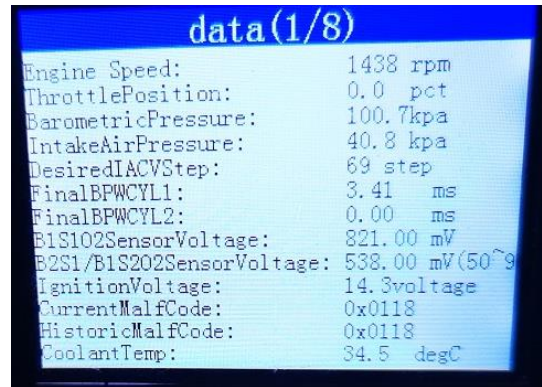

4. Data Record

Select 'Read Date'  , and press [↵] → it will display function list as right.



Press ▼ to select 'Record Data' , and press [↵].it will display as right. (The recorded data can be used to analyze engine conditions) →

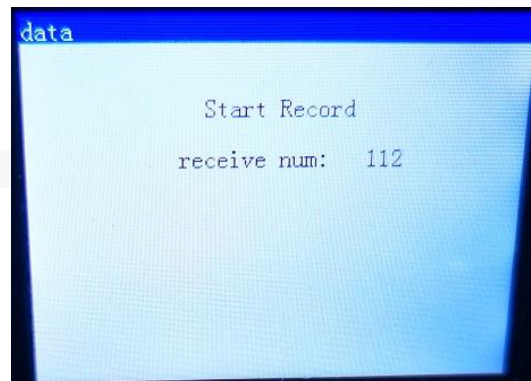

3.5.9.4 MT05.3 ECU Malf Code

Malf code	Description
P0118	Coolant/Oil Temperature Sensor Circuit High Voltage or Open
P0117	Coolant/Oil Temperature Sensor Circuit Low Voltage
P0116	Coolant/Oil Temperature Sensor Signal Malfunction
P1116	Performance/Out of Range
P0336	CKP Sensor Noisy Signal
P0335	CKP Sensor No Signal
P2301	Cylinder 1 Ignition Coil "A" Short to High Voltage
P2300	Cylinder 1 Ignition Coil "A" Short to Low Voltage/Open
P0123	TPS Circuit Short to High Voltage
P0122	TPS Circuit Low Voltage to Open
P0459	CCP Short to High Voltage
P0458	CCP Short to Low/Open
P00D1	Cylinder 1 Sensor Heater Circuit Low Current (Heater failure)
P0232	Fuel Pump Relay Short to High Voltage
P0231	Fuel Pump Relay Short to Low Voltage/Open
P014D	Cylinder 1 Sensor Reaction Time From Thin to Thick Slow
P014C	Cylinder 1 Sensor Reaction Time From Thick to Thin Slow
P0601	ECM Read-Only Memory Check Error ECM
P0262	Cylinder 1 Fuel Injector Short to High Voltage
P0261	Cylinder 1 Fuel Injector Short to Low Voltage/Open
P3106	Steady State Intake Pressure Low
P0108	MAP Sensor Circuit High Voltage
P0107	MAP Sensor Circuit Low Voltage or Open
P0105	MAP Signal Stuck
P0114	ITA Signal Erratic change
P0113	IAT Circuit High Voltage or Open

P0112	IAT Circuit Low Voltage
P0111	IAT Signal Stuck
P0650	MIL Circuit Malfunction
P2195	Cylinder 1 Sensor PE Thin
P0132	O2S 1 Circuit High Voltage
P0131	O2S 1 Circuit Low Voltage
P0300	Misfire incident detected
P0301	Cylinder 1 Misfire
P0031	Cylinder 1 O2S Sensor Heater Short to Low Voltage/Open
P0032	Cylinder 1 O2S Sensor Heater Short to High Voltage
P0563	System Voltage High
P0562	System Voltage Low
P0500	VSS No Signal
P2257	Secondary Air Supply Valve Open/Short to Low Voltage
P2258	Secondary Air Supply Valve Short to High Voltage
P0850	Park Neutral Switch Error
P1693	Tachometer Circuit Low Voltage
P1694	Tachometer Circuit High Voltage
P0505	Idle Speed Control Error

3.6. Cooling and Lubrication System

Engine Coolant.....	3.6.1
Inspection of Cooling Circuit.....	3.6.2
Inspection and Cleaning of Radiator and Water Hoses.....	3.6.3
Inspection of Fan Motor.....	3.6.4
Inspection of Water Temperature Sensor.....	3.6.5
Inspection of Thermostat.....	3.6.6
Water Pump.....	3.6.7
Water Pump Removal and Disassembly.....	3.6.7.1
Inspection.....	3.6.7.2
Water Pump Assembly and Installation.....	3.6.7.3
Lubrication System Illustration.....	3.6.8

3.6.1 Engine Coolant

The coolant used in cooling system is a 100% ethylene glycol antifreeze.

Warning !
 DO NOT open radiator cap when the engine is still hot. Or you may be injured by scalding fluid or steam;
 Coolant is harmful. DO NOT swallow or stain your skin or eyes with coolant. In case of accidental swallow or stains, flush with plenty of water and consult the doctor immediately.
 Keep coolant away from reach of children.

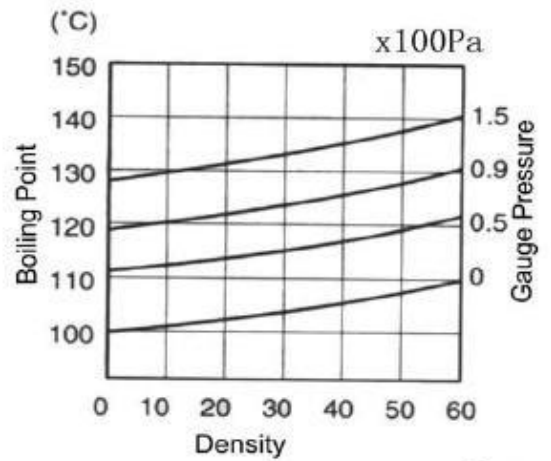

3.6.2 Inspection of Cooling Circuit

Remove radiator cap ① and connect tester ② to filler.

Warning!
 Do not open the radiator cap when the engine is still hot.

Give a pressure of 120 kPa and check if the cooling system can hold this pressure for 10 seconds.

If the pressure drops during this 10 seconds, it indicates that there is leakage with the cooling system. In this case, check the complete system and replace the leaking parts or components.

Warning!
 When removing the radiator cap tester, put a rag on the filler to prevent splash of coolant.

Warning!
 Do not allow a pressure to exceed the radiator cap release pressure.



3.6.3 Inspection and Cleaning of Radiator and Water Hoses

Radiator Cap

- Remove radiator cap①
- Install radiator cap to cap tester②

Slowly increase pressure to 110-140 kPa and check if the cap can hold the pressure for at least 10 seconds.

If the cap cannot meet the pressure requirement, replace it.

Radiator Cap Valve Opening Pressure:

Standard: 110-140 kPa

Tool: Radiator Cap Tester

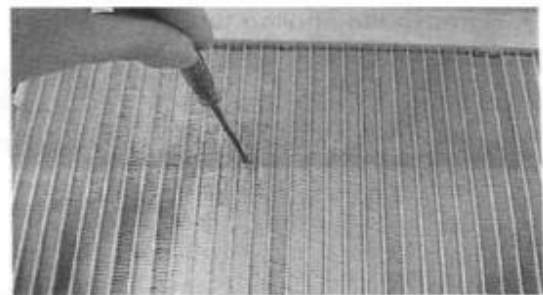
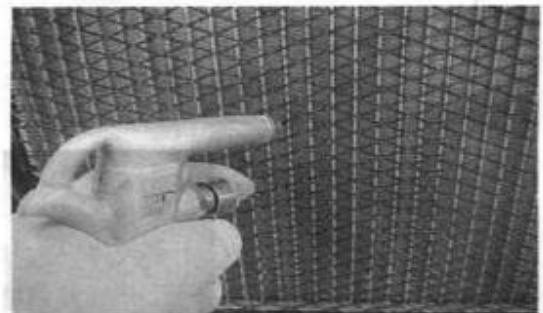
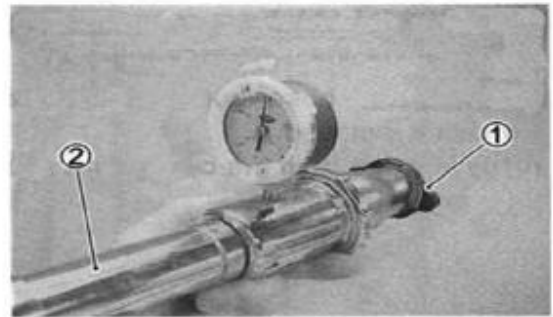

Radiator Inspection and Cleaning

Remove dirt or trash from radiator with compressed air;

Correct the radiator fins with a small screwdriver;

Radiator Hose Inspection

Check radiator hoses for leakage or damage.

Leakage or Damage: → Replace

Check tightening of clamps. Replace the clamps if necessary;

After inspection and cleaning of radiator and hoses, check coolant level. Fill coolant if necessary.

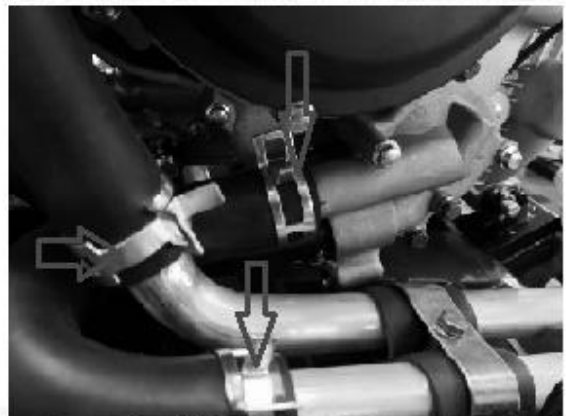

3.6.4 Inspection of Fan Motor

Remove fan motor from radiator

Turn the vanes and check if they can turn smoothly;

Check fan motor: Make sure that the battery applies 12 volts to the motor and the motor will run at full speed while the ammeter shall indicate the ampere not more than 5A.

If the motor does not run or the ampere exceeds the limit, replace the motor.

Installation: Apply a little thread locker to the bolts and tighten to the specified torque.

Fan Motor Bolt Tightening Torque: 10N•m

- 1. Radiator
- 2. Radiator Cap
- 3. Fan Motor
- 4. Mounting Nut, Fan Motor

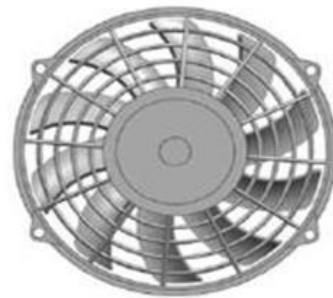
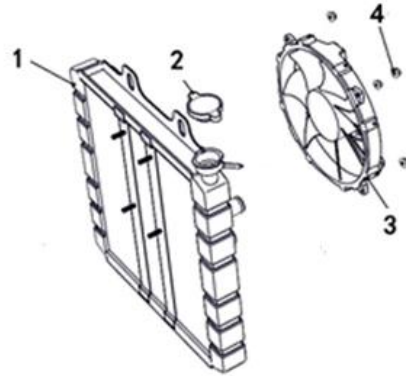

3.6.5 Inspection of Water Temperature Sensor

Place a rag under water temperature sensor① and remove it from cylinder head.

Check the resistance of water temperature sensor as illustrated on the right. Connect the temperature sensor② to the circuit tester, place it in a vessel with engine oil. Place the vessel above a stove. Heat the oil to raise the temperature slowly and take the reading from thermometer ③ and ohmmeter ④ .



Water Temperature and Resistance(terminal a- terminal c)

Temperature(°C)	50	80	100	120
Resistance(Ω)	980±2.2%	334±2%	178±2.3%	101±2.7%

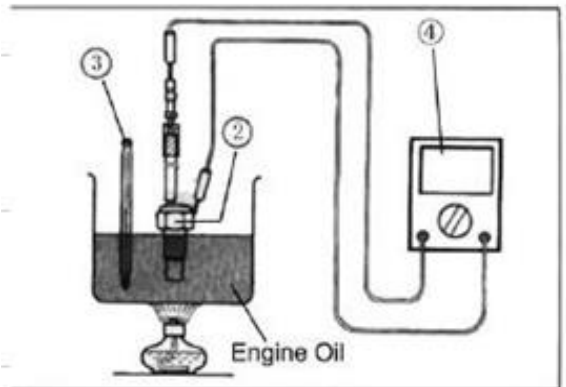

Installation: Apply a little thread locker and install it to the cylinder head by tightening to the specified torque.

Water Temperature Sensor

Tightening Torque: 10N•m

Note:
 Avoid sharp impact on temperature sensor
 Avoid contact of temperature sensor with thermometer or vessel

After installation, check the coolant level. Fill coolant if necessary.

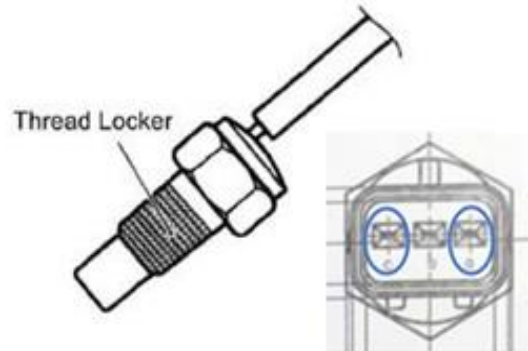

3.6.6 Inspection of Thermostat

Remove thermostat case

Remove thermostat

Check thermostat pellet for cracks
 Test the thermostat in the following steps:

Pass a string between thermostat flange as illustrated on the right;
 Immerse the thermostat in a beaker with water.
 Make sure that the thermostat is in the suspended position without contact to the vessel. Heat the water by placing the beaker above a stove and observe the temperature rise on a thermometer;
 Take the temperature reading from thermometer when the thermostat valve opens.

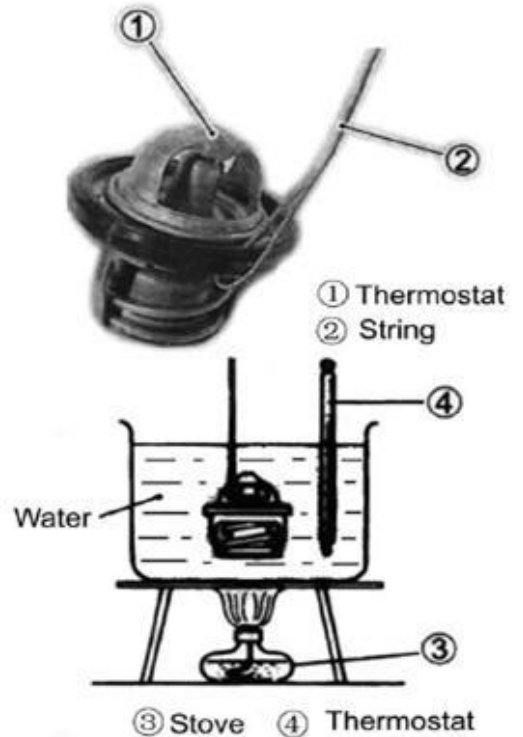

Thermostat Valve Opening Temperature: 68-74°C

Keep heating the water to raise the water temperature.

Just when the water temperature reaches the specified value, the thermostat valve should have been lifted by 3.5-4.5mm

Installation:

Reverse the removal procedure for installation.

Apply coolant to the rubber seal of thermostat.

Install thermostat case. Tighten to the specified torque:

Tightening Torque: 10N•m

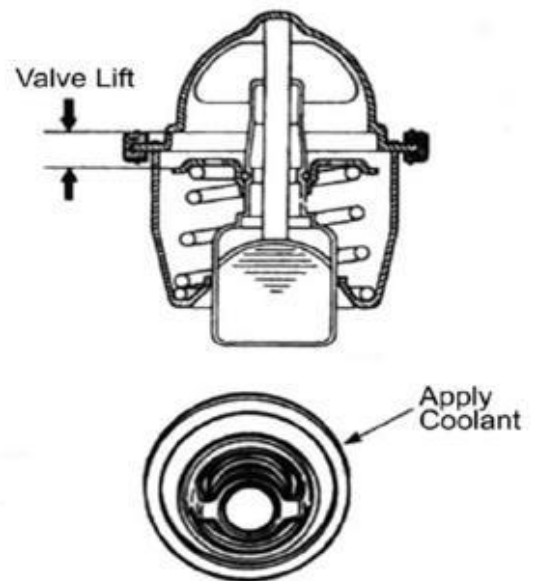

3.6.7 Water Pump

3.6.7.1 Removal and Disassembly

Drain coolant

Note: Before draining coolant, check water pump for oil or coolant leakage. In case of oil leakage, check the water pump oil seal, O-ring. In case of coolant leakage, check the water seal.

Remove clamps and water hoses

Release bolts and remove water pump

Remove O-ring



Note: Do not reuse the O-ring.

Remove the overflow tube

Release water pump cover screws, water pump cover and gasket



Remove E-ring and impeller



Remove seal ring ① and rubber seal ②



Remove mechanical seal with special tool

- Note:** The mechanical seal does not need to be removed if there is no abnormal condition.
- Note:** Do not reuse a removed mechanical seal

Put a rag on the water pump body

Remove oil seal

- Note:** The oil seal does not need to be removed if there is no abnormal condition
- Note:** Do not reuse a removed oil seal

Remove bearing with special tool.

- Note:** The bearing does not need to be removed if there is no abnormal noise.
- Note:** Do not reuse a removed bearing.

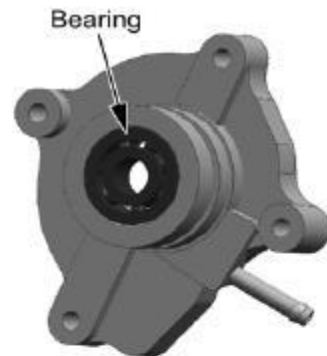
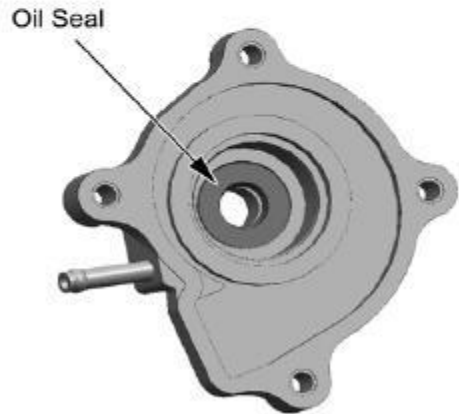

3.6.7.2 Inspection of Water Pump

Bearing

- Check the play of bearing by hand while it is still in the water pump body;
- Turn inner race of bearing to check for abnormal noise and smooth rotation;
- Replace the bearing if there is abnormal condition;

Mechanical Seal

- Check mechanical seal for damage, pay special attention to the seal face;
- In case of leakage or damage, replace the mechanical seal. If necessary, also replace the seal ring.

Oil Seal

Check oil seal for damage. Pay special attention to the oil seal lip;

In case of damage or leakage, replace the oil seal;



Water Pump Body

Check the mating mace of water pump body with bearing and mechanical seal.

Damage: → **Replace**

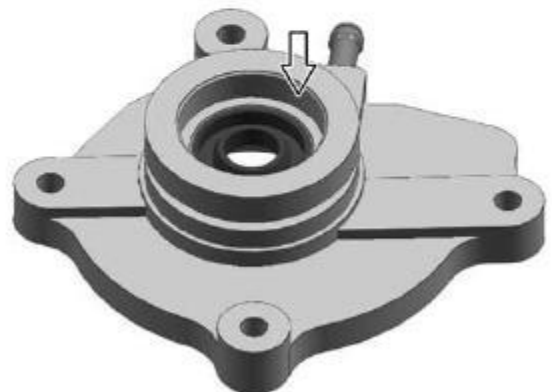

Impeller

Check the impeller and shaft for damage.

Damage: → **Replace**

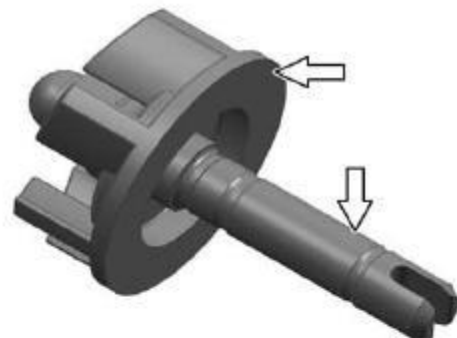

3.6.7.3 Assembly and Installation of Water Pump

Install oil seal with special tool;

Tool: Oil Seal Installer

Note: The stamped mark on the oil seal faces outside

Apply a little grease to the oil seal lip.

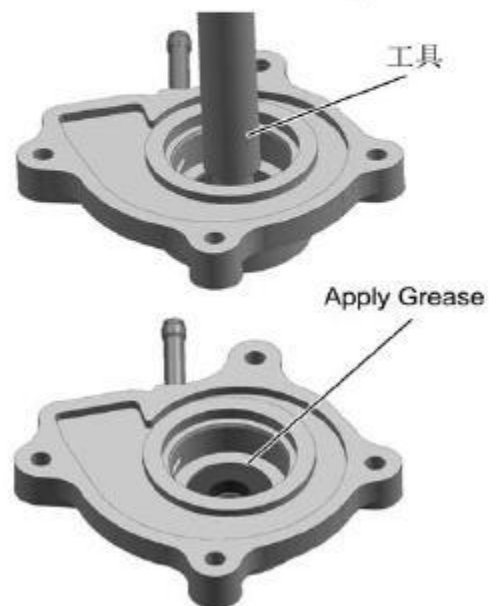

Install mechanical seal with a suitable socket wrench

Note: Apply sealant to side "A" of mechanical seal

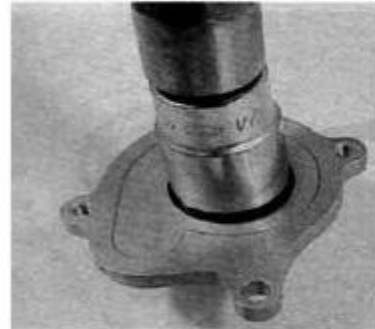

Install bearing with special tool

Tool: Bearing Installer

Note: The stamped mark on the bearing faces outside.

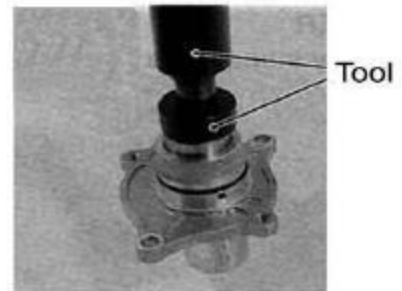

Install seal ring to impeller

Clean off the oil and grease from mechanical seal and install it into the impeller.

Note: "A" side of mechanical seal faces impeller

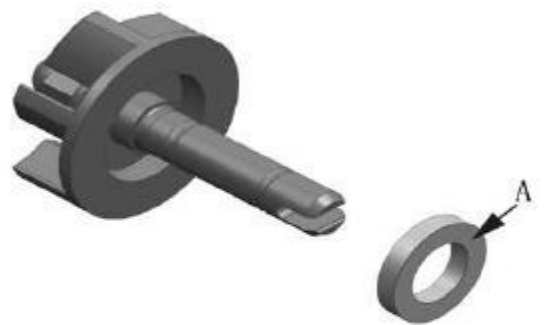

Apply grease to impeller shaft

Install impeller shaft to water pump body.

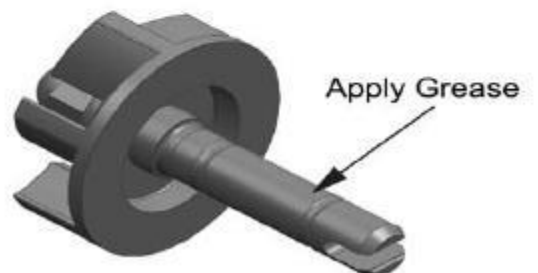

Install E-ring to water pump shaft;



Install new gasket to water pump body;

Install water pump cover and tighten the bolts and bleed bolt.

Water Pump Cover Bolts Tightening Torque: 6N•m



Check impeller for smooth turning.

Install the new O-ring

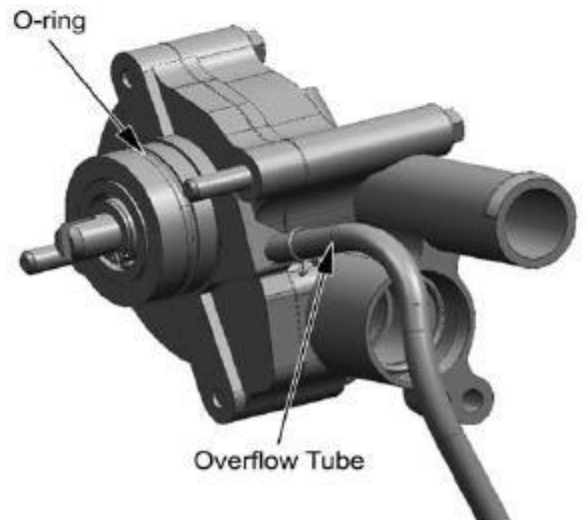

Note:
Use the new O-ring to prevent oil leakage;
Apply grease to O-ring

Install water pump and tighten the bolts to the specified torque;

Water pump bolts tightening torque: 10N•m

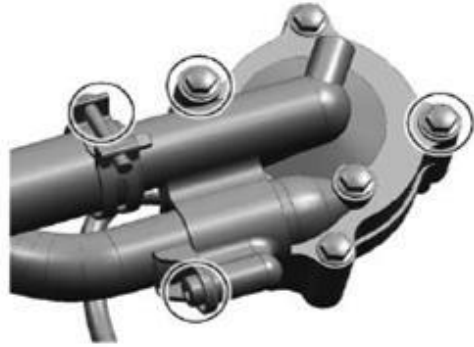

Note: Set the water pump shaft slot end “B” to oil pump shaft flat side “A”.

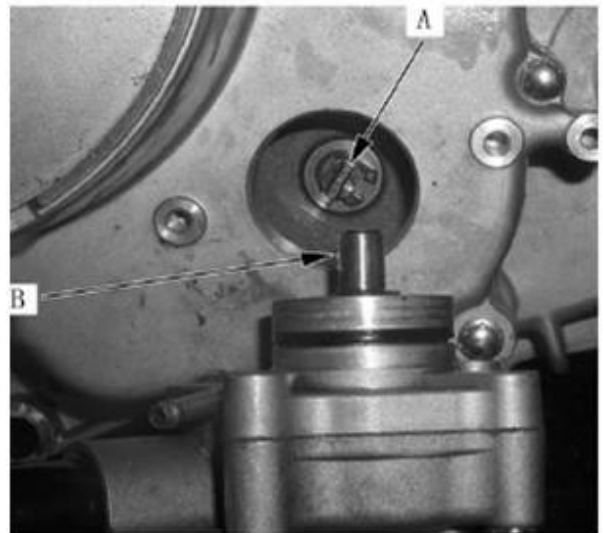

Connect water hoses

Add coolant

3.6.7.8 Lubrication System Illustration

Illustration of Engine Lubrication System

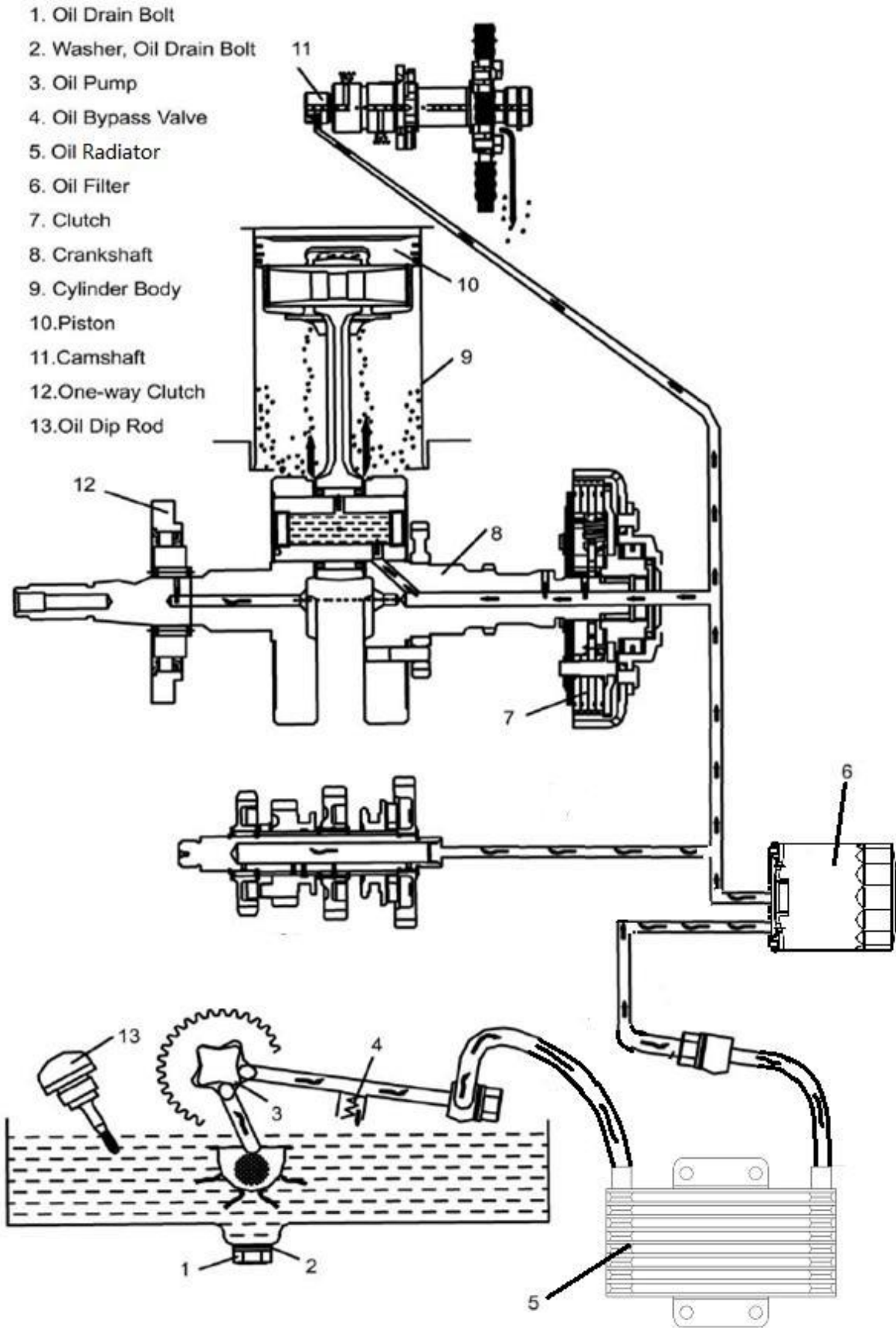

3.7 TROUBLESHOOTING

GENERAL INFORMATION

TIP

The following guide for troubleshooting does not cover all the possible causes of trouble. It should be helpful, however, as a guide to basic troubleshooting. Refer to the relative procedure in this manual for checks, adjustments, and replacement of parts.

STARTING FAILURES

Engine

1. Cylinder and cylinder head
 - Loose spark plug
 - Loose cylinder head or cylinder
 - Damaged cylinder head gasket
 - Damaged cylinder gasket
 - Worn or damaged cylinder
 - Incorrect valve clearance
 - Improperly sealed valve
 - Incorrect valve-to-valve-seat contact
 - Incorrect valve timing
 - Faulty valve spring
 - Seized valve
2. Piston and piston ring(s)
 - Improperly installed piston ring
 - Damaged, worn or fatigued piston ring
 - Seized piston ring
 - Seized or damaged piston
3. Air filter
 - Improperly installed air filter
 - Clogged air filter element
4. Crankcase and crankshaft
 - Improperly assembled crankcase
 - Seized crankshaft

Fuel system

1. Fuel tank
 - Empty fuel tank
 - Clogged fuel tank breather hose joint
 - Clogged fuel tank breather hose joint hose
 - Deteriorated or contaminated fuel
2. Fuel pump
 - Faulty fuel pump
 - Faulty fuel injection system relay
 - Clogged or damaged fuel hose
3. Throttle body
 - Deteriorated or contaminated fuel
 - Sucked-in air

Electrical system

1. Battery
 - Discharged battery
 - Faulty battery
2. Fuse(s)
 - Blown, damaged or incorrect fuse
 - Improperly installed fuse
3. Sparkplug
 - Incorrect spark plug gap
 - Incorrect spark plug heat range
 - Fouled spark plug
 - Worn or damaged electrode
 - Worn or damaged insulator
 - Faulty spark plug cap
4. Ignition coil
 - Cracked or broken ignition coil body
 - Broken or shorted primary or secondary coils
 - Faulty spark plug lead
5. Ignition system
 - Faulty ECU
 - Faulty crankshaft position sensor
 - Broken generator rotor woodruff key
6. Switches and wiring
 - Faulty main switch
 - Broken or shorted wiring
 - Faulty gear position switch
 - Improperly grounded circuit
 - Loose connections
 - Faulty brake light switch
7. Starting system
 - Faulty starter motor
 - Faulty starter relay
 - Faulty starter clutch

INCORRECT ENGINE IDLING SPEED

Engine

1. Cylinder and cylinder head
 - Incorrect valve clearance
 - Damaged valve train components
2. Air filter
 - Clogged air filter element

Fuel system

1. Throttle body
 - Damaged or loose throttle body joint
 - Improper throttle cable free play
 - Flooded throttle body
 - Faulty air induction system

Electrical system

1. Battery
 - Discharged battery

- Faulty battery
- 2. Sparkplug
 - Incorrect spark plug gap
 - Incorrect spark plug heat range
 - Fouled spark plug
 - Worn or damaged electrode
 - Worn or damaged insulator
 - Faulty spark plug cap
- 3. Ignition coil
 - Broken or shorted primary or secondary coils
 - Faulty spark plug lead
 - Cracked or broken ignition coil
- 4. Ignition system
 - Faulty ECU
 - Faulty crankshaft position sensor

- Broken generator rotor woodruff key

POOR MEDIUM-AND-HIGH-SPEED PERFORMANCE

Refer to 'STARTING FAILURES" on Previous page.

Engine

1. Air filter
 - Clogged air filter element

Fuel system

1. Fuel pump
 - Faulty fuel pump

FAULTY DRIVE TRAIN

The following conditions may indicate damaged shaft drive components:

Symptoms	Possible Causes
1. A pronounced hesitation or "jerky" movement during acceleration, deceleration, or sustained speed. (This must not be confused with engine surging or transmission characteristics.) 2. A "Tolling amble" noticeable at low speed; a high-pitched whine; a "clink" from a shaft drive component or area. 3. A locked-up condition of the shaft drive mechanism, no power transmitted from the engine to the front and/or rear wheels.	A. Bearing damage. B. Improper gear backlash. C. Gear tooth damage. D. Broken drive shaft. E. Broken gear teeth. F. Seizure due to lack of lubrication. G. Small foreign objects lodged between the moving parts.

TIP

Areas A, B, and C above may be extremely difficult to diagnose. The symptoms are quite subtle and difficult to distinguish from normal vehicle operating noise. If there is reason to believe these components are damaged, remove the components and check them.

FAULTY GEAR SHIFTING**Shifting is difficult**

Refer to "FAULTY CLUTCH" on next page.

EJSDCDICDI

SHIFT LEVER DOES NOT MOVE**Shift drum and shift forks**

- Foreign object in a shift drum groove
- Seized shift fork
- Bent shift fork guide bar

Transmission

- Seized transmission gear
- Foreign object between transmission gears
- Improperly assembled transmission

JUMPS OUT OF GEAR**Shift forks**

- Worn shift fork

Shift drum

- Incorrect axial play
- Worn shift drum groove

Transmission

- Worn gear dog

FAULTY CLUTCH**Engine operates but vehicle will not move**

1. V-belt
 - Bent, damaged or worn V-belt
 - Slipping V-belt
2. Primary pulley cam and primary pulley slider
 - Damaged or worn primary pulley cam
 - Damaged or worn primary pulley slider
3. Clutch spring(s)
 - Damaged clutch spring
4. Transmission gear(s)
 - Damaged transmission gear

Clutch slips

1. Clutch spring(s)
 - Damaged, loose or worn clutch spring
2. Clutch shoe(s)
 - Damaged or worn clutch shoe
3. Primary sliding sheave
 - Seized primary sliding sheave

Poor starting performance

1. V-belt
 - V-belt slips
 - Oil or grease on the V-belt
2. Primary sliding sheave
 - Faulty operation
 - Worn pin groove
 - Worn pin
- 3 Clutch shoe
 - Bent, damaged or worn clutch shoe

Poor speed performance

1. V-belt
 - Oil or grease on the V-belt
2. Primary pulley weights)
 - Faulty operation
 - Worn primary pulley weight
3. Primary fixed sheave
 - Worn primary fixed sheave
4. Primary sliding sheave
 - Worn primary slicing sheave
- 5 Secondary fixed sheave
 - Worn secondary fixed sheave
6. Secondary sliding sheave
 - Worn secondary sliding sheave

OVERHEATING**Engine**

1. Clogged coolant passages
- 2 Cylinder head and piston
 - Heavy carbon buildup
- 3.Engine oil
 - Incorrect oil level
 - Incorrect oil viscosity
 - Inferior oil quality

Cooling system

1. Coolant
 - Low coolant level
- 2 Radiator
 - Damaged or leaking radiator
 - Faulty radiator cap
 - Bent or damaged radiator fin
- 3 Water pump
 - Damaged or faulty water pump
- 4.Thermostat
 - Thermostat stays closed
- 5 Oil cooler
 - Clogged or damaged oil cooler
- 6 Hose(s) and pipe(s)
 - Damaged hose
 - Improperly connected hose
 - Damaged pipe
 - Improperly connected pipe

Fuel system

1. Throttle body
 - Faulty throttle body
 - Damaged or loose throttle body joint
- 2 Air filter
 - Clogged *air* filter element

Chassis

1. Brake(s)
 - Dragging brake

Electrical system

1. Sparkplug
 - Incorrect spark plug gap
 - Incorrect spark plug heat range
- 2 Ignition system
 - Faulty ECU
- 3 Radiator fan
 - Faulty fan motor
 - Disconnected circuit breaker terminal
 - Faulty coolant temperature sensor

OVERCOOUNG

Cooling system

1. Thermostat
 - Thermostat stays open

POOR BRAKING PERFORMANCE

- Worn brake pad
- Worn brake disc
- Air in hydraulic brake system
- Leaking brake fluid
- Faulty brake caliper kit
- Faulty brake caliper seal
- Loose union bolt
- Damaged brake hose
- Oil or grease on the brake disc
- Oil or grease on the brake pad
- Incorrect brake fluid level

FAULTY SHOCK ABSORBER ASSEMBLY

Leaking oil

- Bent damaged or rusty damper rod
- Cracked or damaged shock absorber
- Damaged oil seal lip

Malfunction

- Fatigued or damaged shock absorber spring
- Bent or damaged damper rod

UNSTABLE HANDING

1. Steering wheel
 - Bent or improperly installed steering wheel
2. Steering components
 - Incorrect toe-in
 - Bent steering shaft
 - Improperly installed steering shaft
 - Damaged bearing or bearing race
 - Bent tie-rods
 - Deformed steering knuckles
3. Shock absorber assemblies)
 - Faulty shock absorber spring
 - Leaking oil or gas
4. Tire(s)
 - Uneven tire pressures (left and right)
 - Incorrect tire pressure
 - Uneven tire wear
- 5 Wheel(s)
 - Incorrect wheel balance
 - Damaged wheel bearing
 - Bent or loose wheel axle
 - Excessive wheel runout

6. Frame
 - Bent frame
 - Damaged frame

FAULTY LIGHTING OR SIGNAUNG SYSTEM

Headlight does not come on

- wrong headlight bulb
- Too many electrical accessories
- Hard charging
- Incorrect connection
- Improperly grounded circuit
- Poor contacts (main or light switch)
- Bunt-out headlight bulb

Headlight bulb bunt out

- Wrong headlight bulb
- Faulty battery
- Faulty rectifier/regulator
- Improperly grounded circuit
- Faulty main switch
- Faulty light switch
- Headlight bulb life expired

Tail/brake light does not come on

- Wrong tail/brake light bulb
- Too many electrical accessories
- Incorrect connection
 - Bunt-out tail/brake light bulb

Tail/brake light bulb burnt out

- Wrong tail/brake light bulb
- Faulty battery
- Faulty brake light switch
- Tail/brake light bulb life expired
- Faulty rectifier/regulator
- Improperly grounded circuit

CHAPTER 4 CHASSIS

WARNING

The parts of different types/ variants/ versions maybe un-interchangeable, even some parts have almost same appearance. Always refer to Parts Manual of each UTV model for spare parts information and service.

4.1 FRONT DOUBLE ARMS REPLACEMENT

4.2 REAR DOUBLE ARMS REPLACEMENT

4.3 REAR STABILIZER BAR REMOVAL/INSTALLATION

4.4 BOX REMOVAL/INSTALLATION

4.5 STEERING ASSEMBLY REMOVAL/INSTALLATION

4.1 FRONT DOUBLE ARMS REPLACEMENT

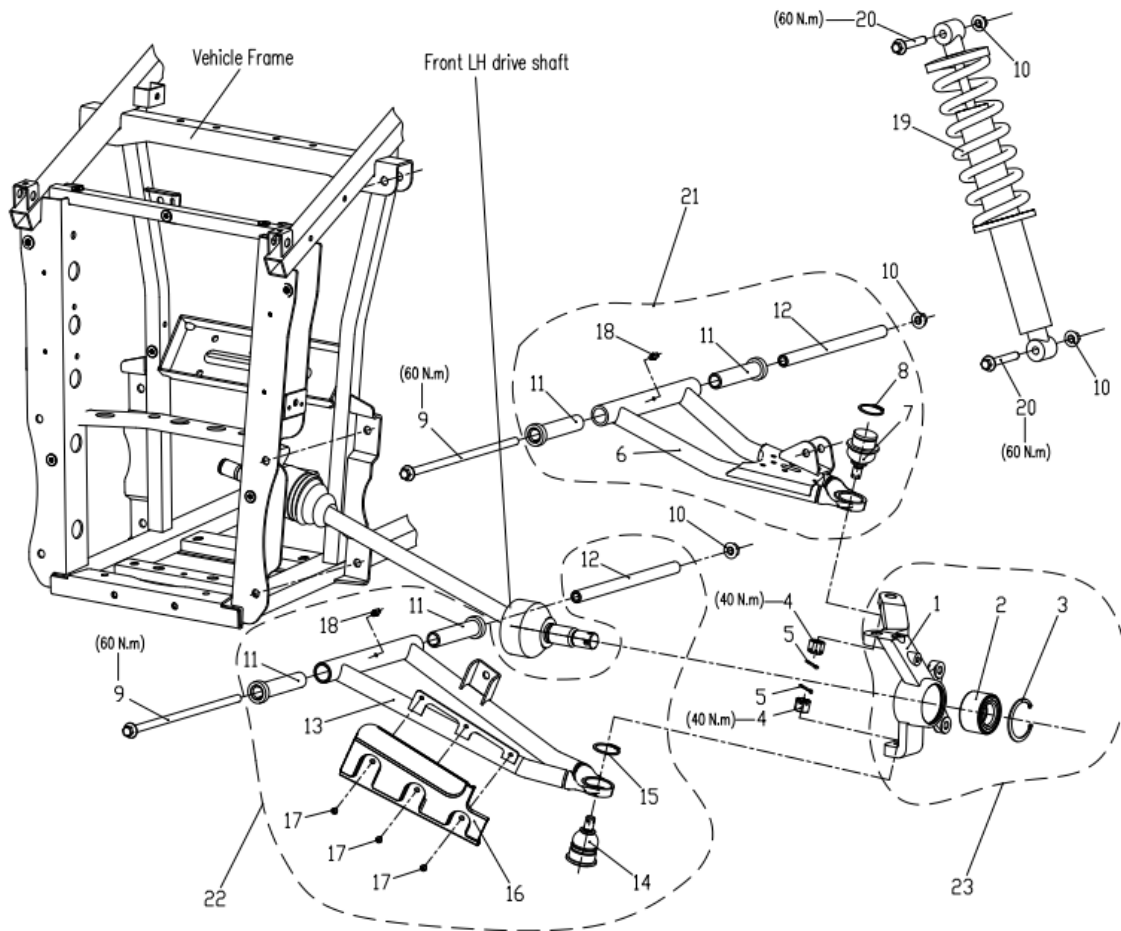

- | | | |
|----------------------------------|-----------------------------|-------------------------------|
| 1. Front Knuckle, Lh; | 2. Bearing; | 3. Circlip 55; |
| 4. Nut M12x1.25; | 5. Pin 3.2x30; | 6. Front Upper Arm, Lh; |
| 7. Ball Joint, Upper; | 8. Circlip 32; | 9. Bolt M10X1.25X260; |
| 10. Nut M10x1.25; | 11. Bushing, Long; | 12. Shaft Pivot; |
| 13. Front Lower Arm, Lh; | 14. Ball Joint, Lower; | 15. Circlip 34; |
| 16. Front Lower Arm Cover, Lh; | 17. Screw M5X10; | 18. Grease Fitting M6; |
| 19. Front Shock Absorber Assy; | 20. Bolt M10X1.25X57; | 21. Front Upper Arm Assy, Lh; |
| 22. Front Lower Arm Lh Assy, Lh; | 23. Front Knuckle Assy, Lh; | |

1. Elevate and safely support vehicle with weight removed from front wheel(s).

2. Remove the wheel nuts and wheel.

NOTE: To ease the removal of the spindle nut, remove the hub cap and loosen the spindle nut before removing the wheel.

3. Remove the brake caliper. Suspend the brake caliper from the frame with a wire.

NOTE: Do not let the brake caliper hang with the brake line, otherwise damage may occur.

4. Remove the spindle nut and washer. Remove the hub assembly by sliding it off the shaft.
5. Remove cotter pin from ball joint stud at wheel end of A-arm and loosen nut until it is flush with end of stud.
6. Using a soft face hammer, peen nut to loosen A-arm from bolt. Remove nut and A-arm from hub strut assembly.
7. Loosen and remove two bolts on A-arm, and remove A-arm.
8. Examine A-arm bushing. Replace if worn or tore. Discard hardware.
9. Install new A-arm assembly to vehicle frame. Install new bolts and new nuts.

NOTE:

Tighten the nuts only finger-tighten at this time. They will be tightened to the final torque after the front wheels are installed and the vehicle is on the ground.

 WARNING

DO NOT reuse old bolts. Serious injury or death could result if fasteners come loose during operation.

10. Attach A-arm to strut assembly. Tighten ball joint nut to 25 ft. lbs. (35 Nm). If cotter pin holes are not aligned, tighten nut slightly to align. Install a new cotter pin with open ends toward rear of machine. Bend both ends in opposite directions around nut.
11. Re-install the hub assembly. Install washer and the spindle nut to 103 ft.lbs (140Nm). Aim the gap of the shaft for use the chisel to hit the nut until it locked.
12. Install the brake caliper. Apply Loctite™ 243 to screw threads of the bolts and torque bolts to 18ft. lbs. (25 Nm).
13. Install the wheel and torque nuts to 55ft. lbs. (75 Nm).
- 14cl. Lower the vehie to the ground. Apply Loctite™ 243 to screw threads of the A arm bolts and torque bolts to 37-44 ft. lbs. (50-60 Nm).

 WARNING

Upon A-arm installation completion, test vehicle at low speeds before putting into regular service.

4.2 REAR DOUBLE ARMS REPLACEMENT

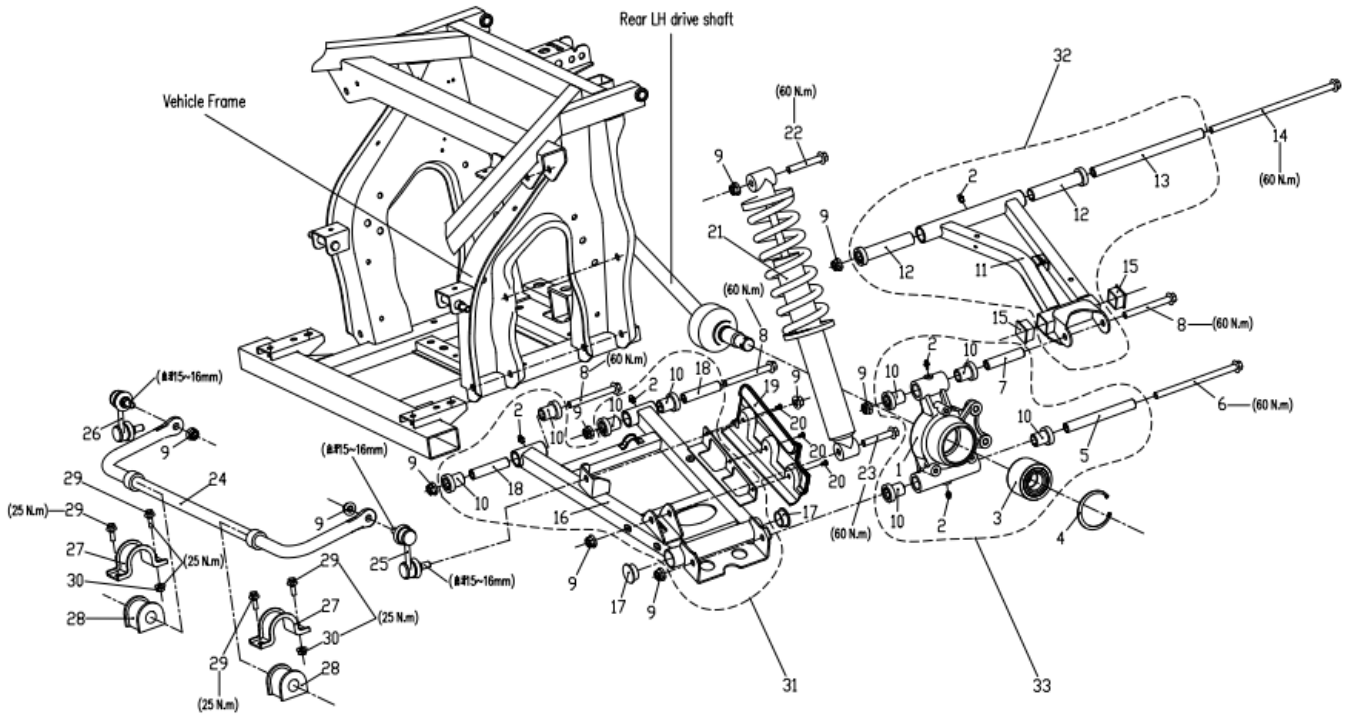

- | | | |
|-------------------------------|------------------------------|------------------------------|
| 1. Rear Knuckle, Lh; | 2. Grease Fitting M6; | 3. Bearing |
| 4. Circlip 63; | 5. Shaft Pivot, Lower; | 6. Bolt M10×1.25×160 |
| 7. Shaft Pivot ,Upper; | 8. Bolt M10×1.25×90; | 9. Nut M10×1.25 |
| 10. Bushing, Short; | 11. Rear Upper Arm, Lh; | 12. Bushing, Long |
| 13. Shaft, Rear Upper Arm; | 14. Bolt M10×1.25×245; | 15. Square Rubber Plug |
| 16. Rear Lower Arm, Lh; | 17. Plug; | 18. Shaft, Rear Lower Arm |
| 19. Rear Lower Arm Cover, Lh; | 20. Screw M5×10; | 21. Rear Shock Absorber Assy |
| 22. Bolt M10×1.25×62.5; | 23. Bolt M10×1.25×57; | 24. Stabilizer Bar |
| 25. Stabilizer Joint, Lh; | 26. Stabilizer Joint, Rh; | 27. Stabilizer Holder |
| 28. Stabilizer Bushing; | 29. Bolt M8×20; | 30. Nut M8 |
| 31. Rear Lower Arm Assy, Lh; | 32. Rear Upper Arm Assy, Lh; | |
| 33. Rear Knuckle Assy, Lh | | |

1. Elevate and safely support vehicle with weight removed from the rear wheel(s).

2. Remove the wheel nuts and wheel.

NOTE: To ease the removal of the spindle nut, remove the hub cap and loosen the spindle nut before removing the wheel.

3. Remove the brake caliper. Suspend the brake caliper from the frame with a wire.

NOTE: Do not let the brake caliper hang with the brake line, otherwise damage may occur.

4. Remove the spindle nut and washer. Remove the hub assembly by sliding it off the shaft.

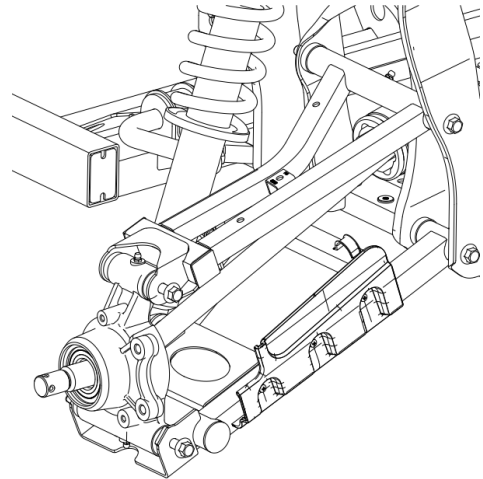

5. Loosen two bolts that secure the rear knuckle to the A-arm. Remove the rear knuckle assembly by sliding it off from the shaft.

6. Remove the bolt that secures the shock and coil to the lower A-arm.

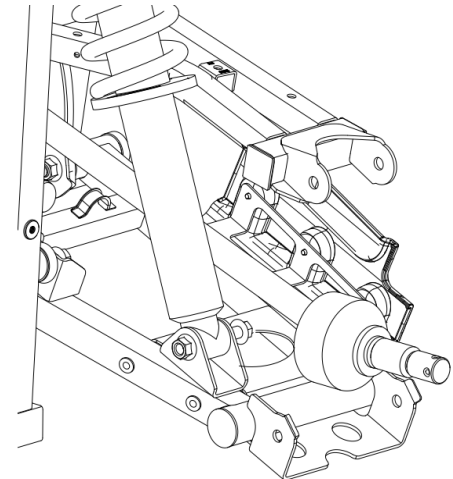

7. Loosen two bolts that secure the A-arm to frame by alternating each about 1/3 of the way until A-arm can be removed. Perform this procedure on the upper A-arm.

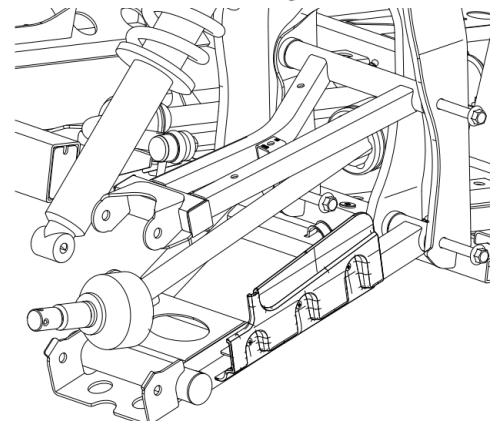

8. Examine the A-arm bushing and A-arm shaft.
Replace if worn. Discard hardware.

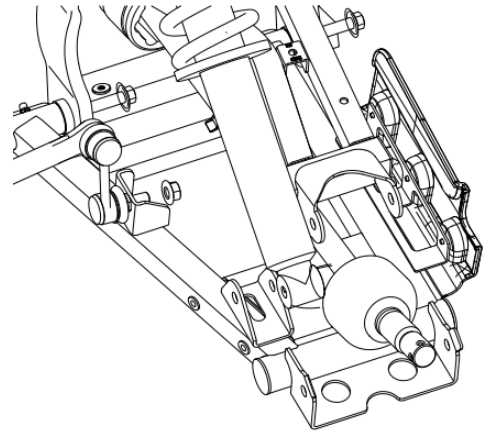

9. Remove the bottom stabilizer bar nut.

10. Loosen two bolts that secure the A–arm bushing to frame by alternating each about 1/3 of the way until the A-arm can be removed. The lower A-arm should now be free to remove.

11. Insert new A-arm bushings and new A-arm shaft into new A-arm.

12. Install new A-arm assembly to vehicle frame. Apply Loctite™ 242 to screw threads of the A arm bolts and torque bolts to 44 ft. lbs. (60 Nm).

⚠ WARNING

DO NOT reuse old bolts. Serious injury or death could result if fasteners come loose during operation.

13. Attach A-arm to rear knuckle. Tighten upper and lower bolts to 44 ft. lbs. (60 Nm).

14. Install the shock and tighten shock bolt to 44 ft. lbs. (60 Nm).

15. Install the stabilizer bar and tighten nut.

16. Re-install the hub assembly. Install washer and the spindle nut to 103 ft.lbs (140Nm). Aim the gap of the shaft for use the chisel to hit the nut until it locked.

17. Install the brake caliper. Apply Loctite™ 243 to screw threads of the bolts and torque bolts to 18ft. lbs. (25 Nm).

18. Install the wheel and torque nuts to 55ft. lbs. (75 Nm).

19. Lower the vehicle to the ground. Apply Loctite™ 243 to screw threads of the arm bolts and torque bolts to 44 ft. lbs. (60 Nm).

⚠ WARNING

Upon A-arm installation completion, test vehicle at low speeds before putting into regular service.

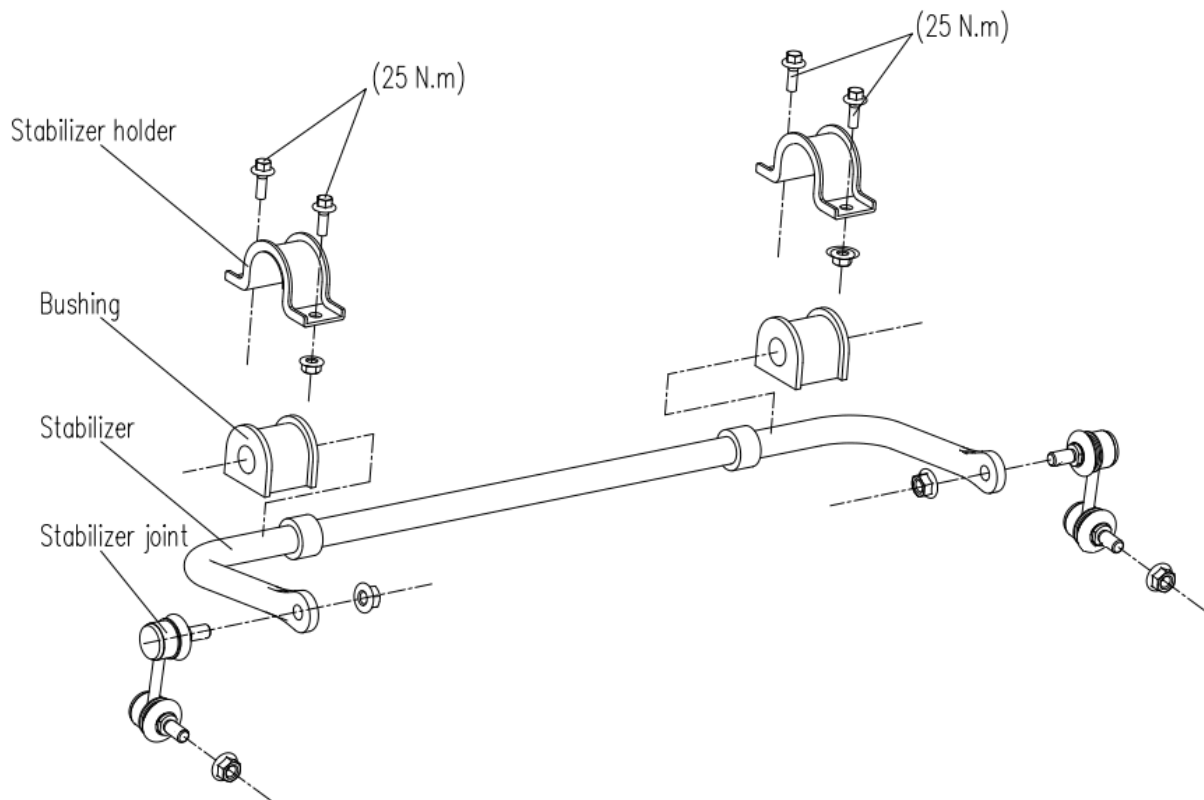
4.3 REAR STABILIZER BAR REMOVAL/INSTALLATION

1. Elevate and safely support vehicle with weight removed from the rear wheel(s).
2. Remove the rear wheel to gain access to the stabilizer bar, each side.
3. Remove the stabilizer bar nut from the lower A-arm, each side.
4. Remove the two bolts that secure the stabilizer bar to the main frame, each side.
5. Remove the stabilizer from the frame.
6. Inspect the stabilizer bar. Inspect the bushings and replace if needed.
7. Inspect the stabilizer joint and replace if needed.
8. Reverse the procedure for installation. Torque the stabilizer bolts to 18.5 ft.lbs (25 Nm).

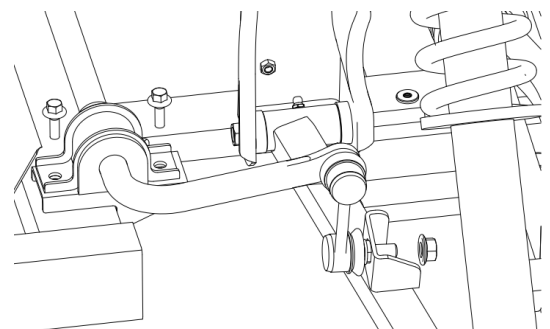
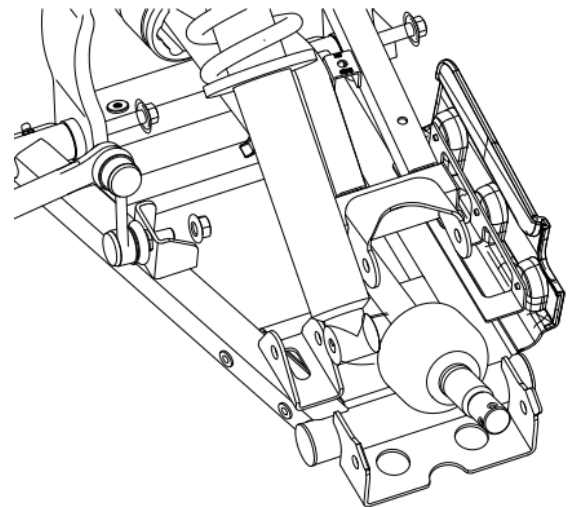

4.4 BOX REMOVAL/INSTALLATION

Box Removal

1. Disconnect taillight transition line at lower left of the Box from the wiring harness.
2. Lift the box into the dump position.
3. Remove the box shock pin from the frame.
4. Remove the shocks from the shock brackets. Let the shocks fully extend.

CAUTION: Safely support the box during the rest of the removal process. The box is not as stable with the shocks removed.

5. Remove bolt from the hinge pin.
6. Remove the hinge pin.

CAUTION: Safely support the box during the rest of the removal process. The box is not as stable with the hinge pin removed.

7. With the hinge pins removed, remove the box from the frame. Two people maybe needed to remove the box from the frame.

CAUTION: Use caution when removing the box. It is recommended to have two people to carefully remove the box from the frame.

Box Installation

1. Place the box on the frame. Align the hinges of the box with the frame.
2. Install the box hinges.
3. Secure the box hinges with the bolts.
4. With the hinges installed, decompress the box shocks and place them into the shock brackets on the frame.
5. Secure the box shocks with the shock pin.
6. Lower the box and secure the latch.
7. Connect taillight transition line to the wiring harness.

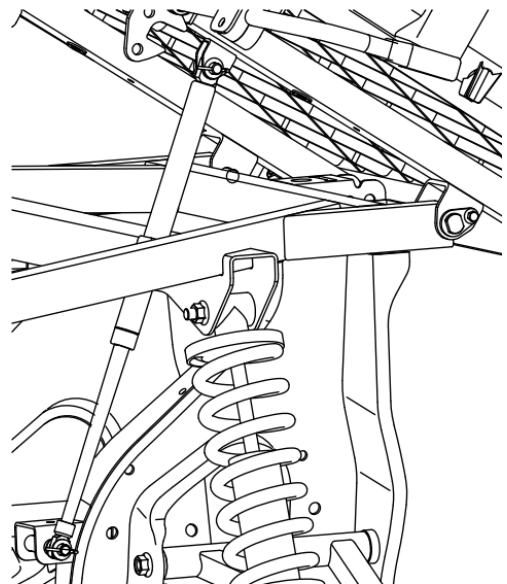
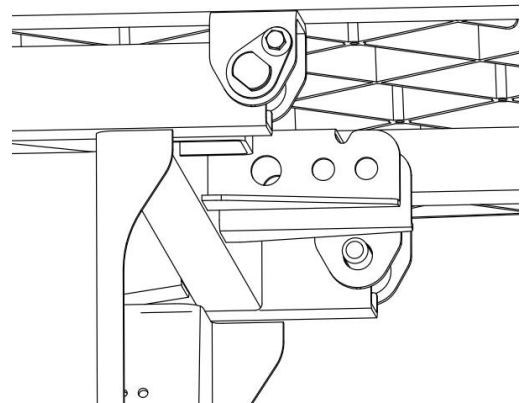
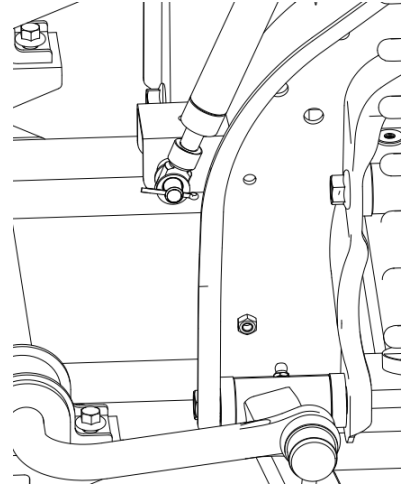

1. With the steering wheel cover bolts removed, remove the steering wheel cover and the steering wheel.
2. With the steering wheel holder nut removed, remove the steering wheel holder.
3. Remove the steering column bolts.
4. Remove the upper of the steering column.
5. Remove the mounting bolts under the steering column.
6. Remove the cotter pins and the tie rod end bolts (both sides).
7. With the cover bolts removed, remove the steering assembly and the lower of the steering column.
8. Reverse the procedure for installation.

CHAPTER 5 FINAL DRIVE

WARNING

The parts of different types/ variants/ versions maybe un-interchangeable, even some parts have almost same appearance. Always refer to Parts Manual of each UTV model for spare parts information and service.

- 5.1 WHEEL, HUB, AND SPINDLE TORQUE TABLE
- 5.2 FRONT HUB EXPLODED VIEW
- 5.3 FRONT HUB REMOVAL/INSPECTION
- 5.4 FRONT HUB INSTALLATION
- 5.5 FRONT HUB BEARING REPLACEMENT
- 5.6 FRONT DRIVE AXLE REMOVAL/ INSPECTION
- 5.7 FRONT DRIVE AXLE INSTALLATION
- 5.8 FRONT DRIVE AXLE DISASSEMBLY/ INSPECTION
- 5.9 FRONT DRIVE AXLE ASSEMBLY
- 5.10 REAR HUB EXPLODED VIEW
- 5.11 REAR HUB AND KNUCKLE REMOVAL/INSPECTION
- 5.12 REAR HUB AND KNUCKLE INSTALLATION
- 5.13 REAR DRIVE SHAFT REMOVAL
- 5.14 REAR DRIVE SHAFT INSTALLATION
- 5.15 REAR GEARCASE EXPLODED VIEW
- 5.16 REAR GEARCASE DISASSEMBLY
- 5.17 REAR GEARCASE ASSEMBLY
- 5.18 FRONT GEARCASE EXPLODED VIEW
- 5.19 FRONT GEARCASE DISASSEMBLY
- 5.20 FRONT GEARCASE ASSEMBLY

5.1 WHEEL, HUB, AND SPINDLE TORQUE TABLE

Item	Specification
Front Wheel Nuts	55 Ft.Lbs 75 Nm
Rear Wheel Nuts	55 Ft.Lbs 75 Nm
Front Hub Nut on Spindle/ outer CV joint	103 Ft.Lbs 140 Nm
Rear Hub Retaining Nut	103Ft.Lbs 140 Nm

Refer to exploded views and text for torque values of other fasteners.

CAUTION: Locking nuts, and bolts with pre-applied locking agent should be replaced if removed. The self- locking properties of the nut or bolt are reduced or destroyed during removal.

5.2 FRONT HUB EXPLODED VIEW

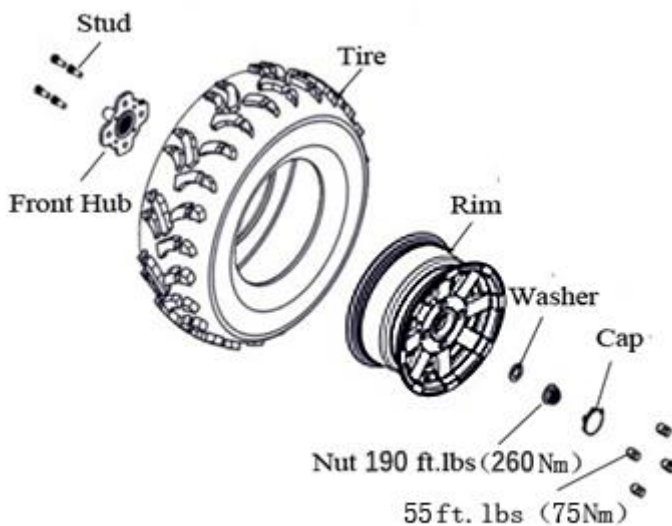

5.3 FRONT HUB REMOVAL/INSPECTION

1. Elevate front end and safely support machine under footrest/frame area.

CAUTION: Serious injury may result if machine tips or falls. Be sure machine is secure before beginning this service procedure. Wear eye protection when removing bearings and seals.

2. Check bearings for side play by grasping the tire/Wheel firmly and checking for movement.

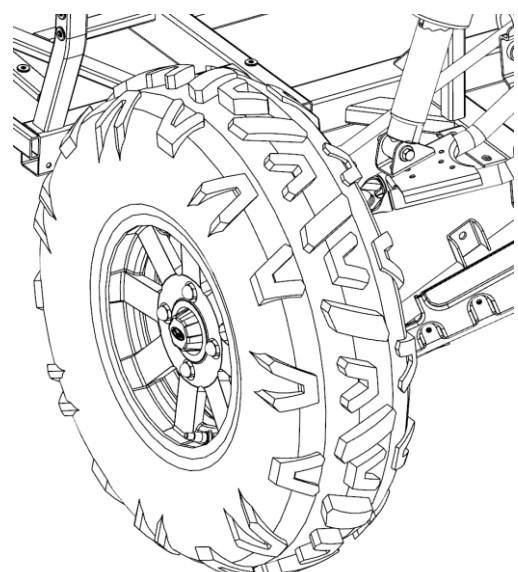

3. Grasp the top and bottom of the tire. The tire should rotate smoothly without binding or rough spots.
4. Remove wheel nuts and wheel.
5. Remove the two brake caliper mounting bolts.

CAUTION: Do not hang the caliper by the brake hose. Use wire to hang the caliper to prevent possible damage to the brake hose.

6. Remove front spindle nut, and washer.
7. Remove front hub assembly.

8. Rotate each bearing by hand and check for smooth rotation. Visually inspect bearing for moisture, dirt, or corrosion, or roughness is evident.

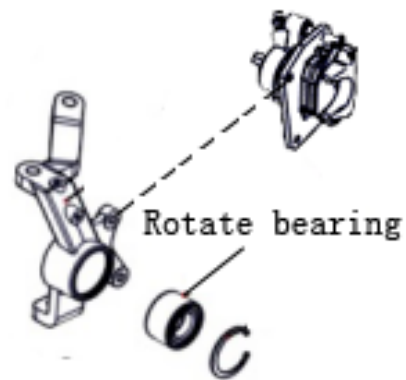
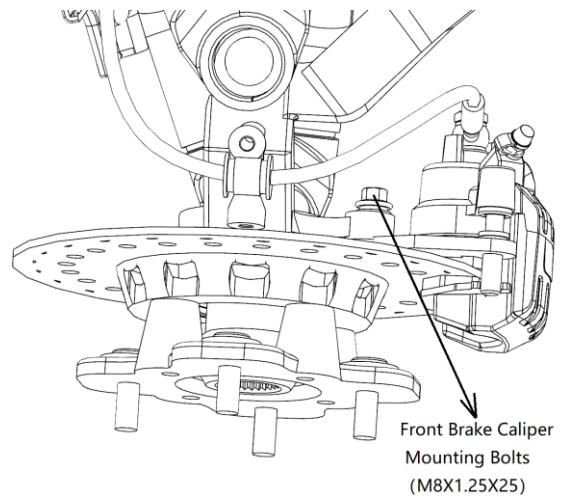

5.4 FRONT HUB INSTALLATION

1. Inspect the hub strut bearing surface for wear or damage.
2. Apply grease to drive axle spindle.
3. Install spindle through the backside of the hub strut. Install the hub onto the spindle.
4. Install spindle nut and tighten to 103 ft.lbs (140Nm).
5. Knock on the edge of the spindle nut, so that it can be clamped into the limit slot.



6. Install brake caliper using new bolts. (Apply Loctite™ 243 to threads) Tighten bolts to 18 ft.lbs (25Nm)

CAUTION: New bolts have a pre-applied locking agent which is destroyed bolts upon removal. Always use new brake caliper mounting bolts upon assembly.

7. Install wheel and wheel nuts and tighten evenly in a cross pattern to specified torque.

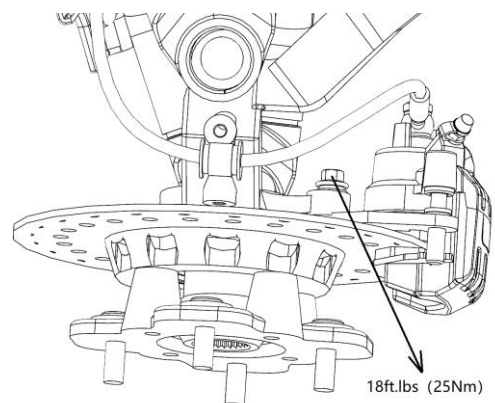

5.5 FRONT HUB BEARING REPLACEMENT

1. Remove outer snap ring.

2. From the back side, tap on the outer bearing race with a drift punch in the reliefs as shown.
3. Drive bearing out evenly by tapping on outer race only. Once bearing is at bottom of casting, support casting on outer edges so bearing can be removed.

4. Inspect bearing.
NOTE: Due to extremely close tolerances and minimal wear, the bearings must be inspected visually, and by feel. While rotating bearings by hand, inspect for rough spots, discoloration, or corrosion. The bearings should turn smoothly and quietly, with no detectable up and down movement and minimal movement sideways between inner and outer race.
5. Inspect bearing housing for scratches, wear or damage. Replace new if damaged.

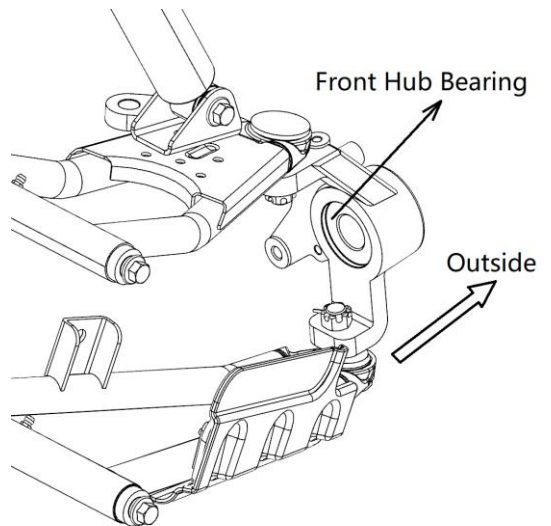
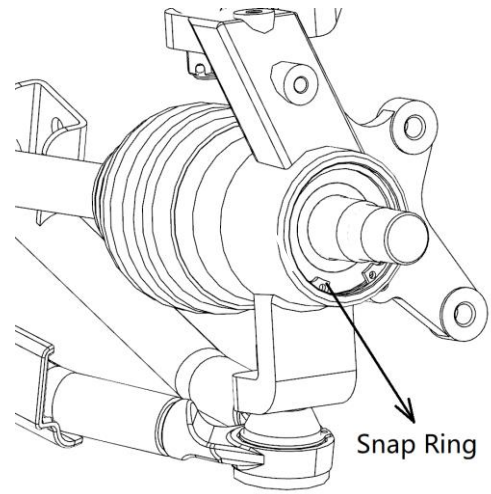

5.6 FRONT DRIVE AXLE REMOVAL/INSPECTION

FRONT DRIVE AXLE

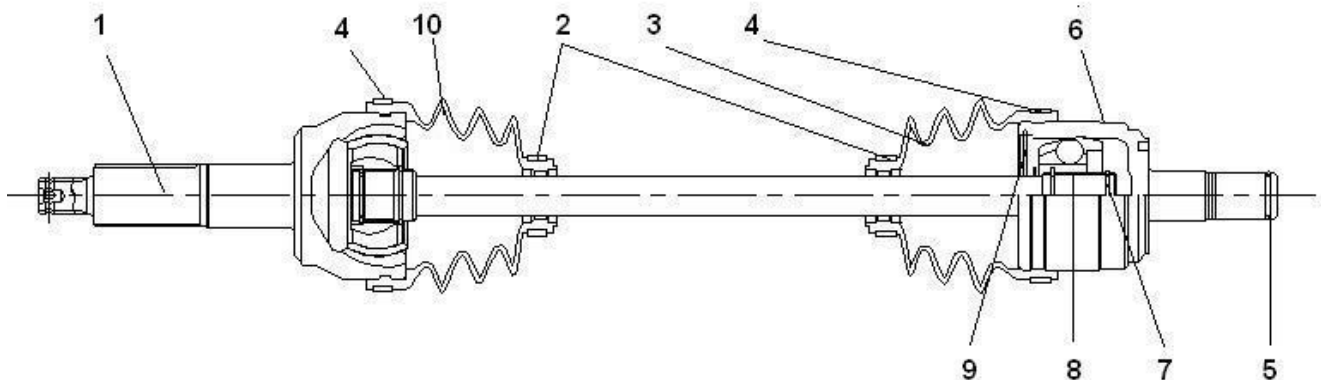

NOTE: The outer CV joint can not be disassembled or repaired, if damage or faulty, the drive axle assembly must be replaced.

1. Drive Axle/Outer CV Joint Assembly.
2. Boot Band "A".
3. Inboard boot.
4. Boot Band "B".
5. Stopper Ring
6. Plunging Joint
7. Circlip
8. Bearing
9. Stopper Ring
10. Outer Board Boot.

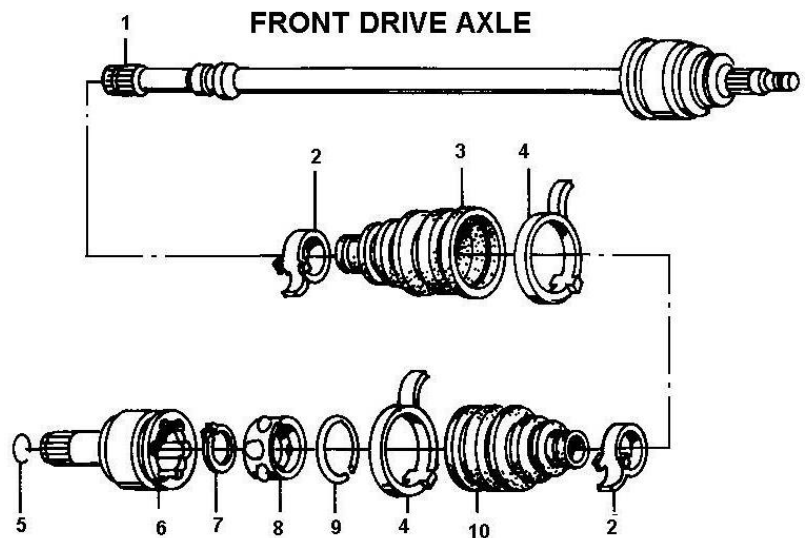

NOTE: Always order and replace 6 and 8 together.

REMOVAL

1. Place the vehicle on level ground and set the parking brake, Block the rear wheels so the vehicle will not roll in either direction.
2. Remove the front wheels, steering tie rods, disconnect the A arm on the ball joint end as described in this Chapter and Chapter 4.

CAUTION: To avoid damage to the front gearcase oil seal, hold the front drive shaft horizontal and straight out from the front gearcase during removal.

3. Hold the drive shaft straight out.
4. Place a tire lever between the inner CV joint and the differential housing, with a small piece of wood against the housing to help get "leverage" and protect the casting. "pop" the inner CV joint out from the front gearcase.

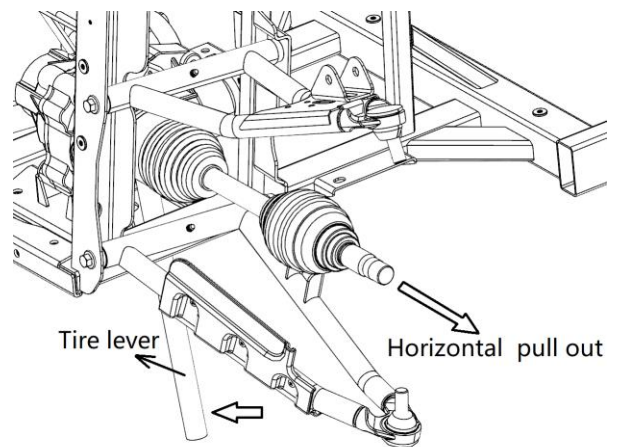

INSPECTION

NOTE: The boots are subjected to a lot of abuse if the vehicle is ridden in rough terrain. If the boots are damage and left un-repaired, the driveshaft joints will fair prematurely by allowing the joint to be exposed to dirt, mud and moisture. This also allow the loss of critical lubrication.

1. Check the rubber boots for wear, cuts or damage and replace if necessary as described under the Disassembly / Assembly procedure in this

chapter.

2. Move each end of the drive shaft in a circular motion (and also a reciprocate for inner one) and check the drive shaft joints for excessive wear or play.
3. This inner CV joint (inboard pivot joint) can be serviced if there is wear or play. The outer CV joint (outboard pivot joint) cannot be serviced if worn or damaged and if necessary, the drive shaft assembly must be replaced.

5.7 FRONT DRIVE AXLE INSTALLATION

CAUTION: To avoid damage to the front gearcase oil seal and the strut oil seal, hold the front drive shaft horizontal and straight into the front gearcase during installation.

1. Hold the drive shaft straight into the front differential.
2. Push the drive shaft straight into the front differential and push it in all the way until it bottoms out. If necessary, carefully tap on the outer end of the drive shaft with a rubber mallet or soft-faced mallet.
3. After the drive shaft is installed, pull the inner CV joint a little to make sure the drive shaft stopper ring has locked into the front differential side gear groove.
4. Carefully install the outer CV joint (spindle) into the strut, install the front hub and wheel.
5. Install the ball joint on the A arm, the steering tie rods, the hubs and the wheels as described in this Chapter and Chapter 4.

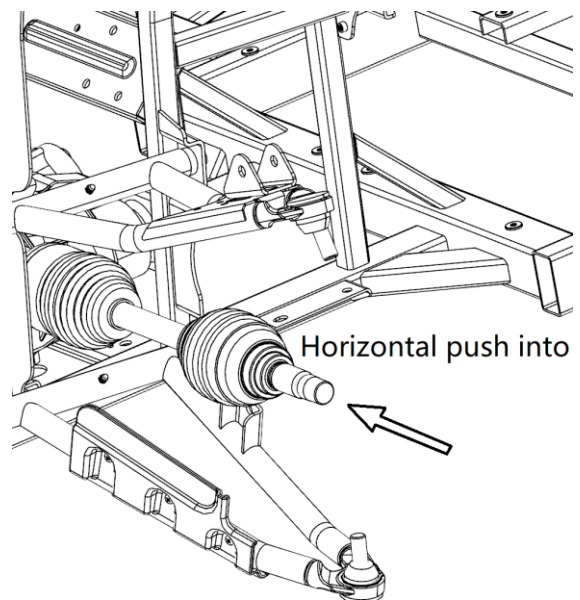

5.8 FRONT DRIVE AXLE DISASSEMBLY/ INSPECTION

INNER CV JOINT DISASSEMBLY

NOTE: The outer CV joint cannot be disassembled or repaired, if damaged or faulty the drive axle assembly must be replaced.

1. Open the clamps on both boot bands "A" and "B" on the inner CV joint, then remove boot band "B".

Discard the boot band, it cannot be reused.

2. Carefully slide the boot (A) onto the drive axle and off the inboard joint.
3. Wipe out all of the molybdenum disulfide grease within the inboard joint cavity.
4. Remove the stopper ring from the inboard joint.
5. Remove the inner CV joint.
6. Remove the circlip and slide off the bearing assembly. Be careful not to drop any of the steel balls from the bearing cage.
7. Slide the inner CV off the drive axle and discard the boot band "A", it cannot be reused.
8. If the outboard boot requires replacement, perform the following:
 - a. Open the clamps on both boot bands "A" and "B" on the outer CV joint, then remove boot band "B". Discard the boot band, it cannot be reused.
 - b. Slide the outboard boot off the drive axle and discard the boot band "A", it cannot be reused.
9. Inspect the drive axle as described in this chapter.



INNER CV JOINT INSPECTION

1. Clean the bearing assembly in solvent and thoroughly dry.
2. Inspect the steel balls, bearing case and the bearing race for wear or damage.
3. Check for wear or damage to the inner splines of the bearing race.
4. If necessary, disassembly the bearing assembly for further inspection. Carefully remove the steel balls from the bearing cage then remove the bearing race from the bearing cage.
5. If any of the components of the bearing assembly are damaged, replace the entire assembly as no replacement parts are available.
6. Clean the inner CV joint in solvent and thoroughly dry.
7. Inspect the interior of the inboard joint where the steel balls ride. Check for wear or damage and replace the joint if necessary.
8. Inspect the snap ring groove on the inboard joint for wear or damage.

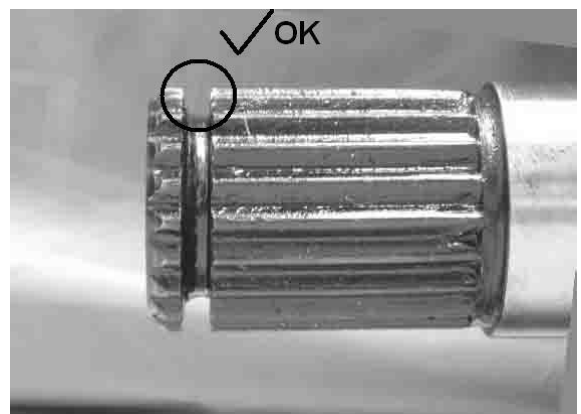

9. Inspect the splines on the inner CV joint for wear or damage.
10. Check the stopper ring in the end of the inboard joint. Make sure it seats in the groove correctly, if damage the ring must be replaced. See right picture.
11. Inspect the exterior of the inner CV joint for cracks or damage, replace if necessary. Check the movement of the joint for excessive play or noise by moving the drive axle in a circular and reciprocate direction.
12. Inspect the drive axle for bending, wear or damage.
13. Inspect the inner end splines, the outer end splines and the front hub cotter pin hole for wear or damage. If any of these areas are worn or damaged, replace the drive axle.

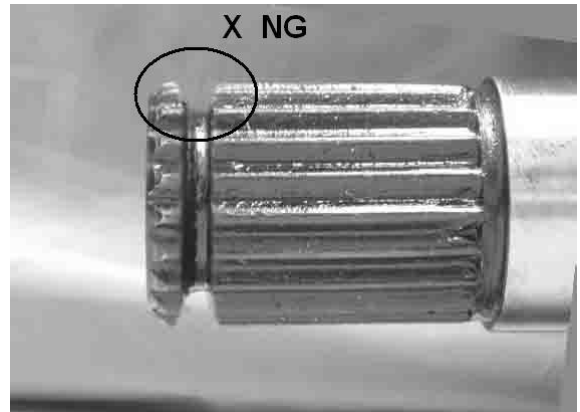

Check the movement of the joint

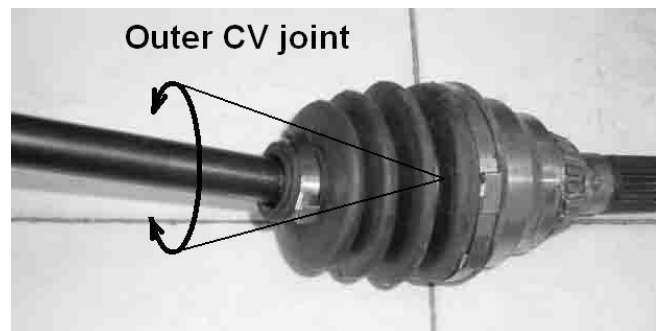
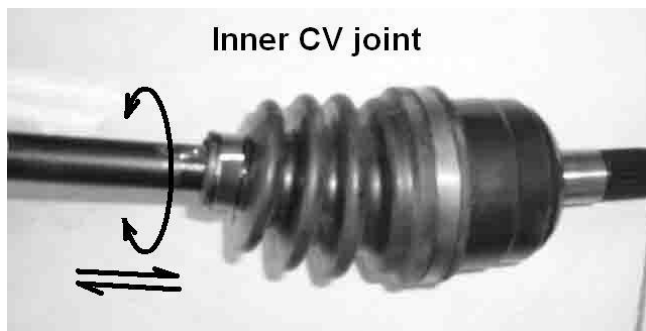

NOTE: Inner CV joint must be replaced with the bearing as an assembly.

5.9 FRONT DRIVE AXLE ASSEMBLY

1. The rubber boots are not identical and must be installed on the correct joint. The boots are marked as follows:
 - a. Inner CV joint boot : "inner",
 - b. Outer CV joint boot: "outer".

2. If the outboard boot was removed, install a new boot onto the drive axle at this time.

NOTE: Position the new boot bands with their tabs facing toward the rear of the vehicle.

3. Install two new small boot bands onto the drive axle.
4. Install the inboard boot and move the small boot band onto the boot. Bend down the tab on the boot band and secure the tab with the locking

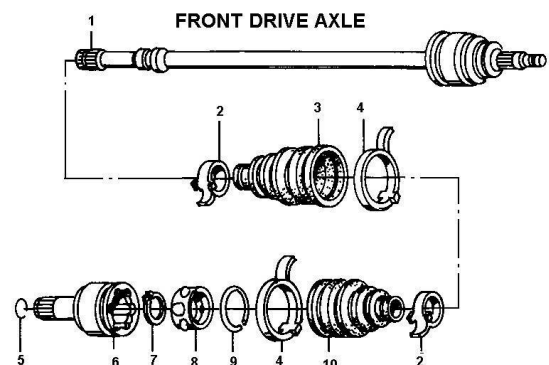

clips and tap them with a plastic hammer. Make sure they are locked in place.

5. If the bearing assembly was disassembled, assemble the bearing as follows:
 - a. Position the bearing race and install the race into the bearing case. Align the steel ball receptacles in both parts.
 - b. Install the steel balls into their receptacles in the bearing case.
 - c. Pack the bearing assembly with molybdenum disulfide grease. This will help hold the steel balls in place.
6. Position the bearing assembly with the small end of the bearing going on first and install the bearing onto the drive axle.
7. Push the bearing assembly on until it stops, then install the circlip. Make sure the circlip seats correctly in the drive axle groove.
8. Apply a liberal amount of molybdenum disulfide grease to the bearing assembly. Work the grease in between the balls, the race and the case. Make sure all voids are filled with grease.
9. Apply a liberal amount of molybdenum disulfide grease to the inner surfaces of the inboard joint.
10. Install the inboard joint over the bearing assembly and install the stopper ring. Make sure it is seated correctly in the inboard joint groove.
11. After the stopper ring is in place, fill the inboard joint cavity behind the bearing assembly with additional molybdenum disulfide grease.
12. Pack each boot with the following amounts of molybdenum disulfide grease:
 - a. Inboard boot: 35-55grams(1.2-1.9oz.).
 - b. Outboard boot: 30-50grams(1.1-1.8oz.).
13. Move the inboard boot onto the inner CV joint.
14. Move the inboard joint on the drive axle.

NOTE: Position the new boot bands with their tabs facing toward the rear of the vehicle .
14. Move the small boot band onto the boot. Bend down the tab on the boot band and secure the tab with the locking clips and tap them with a plastic hammer. Make sure they are locked in place.
15. Install the large boot bands onto each boot.

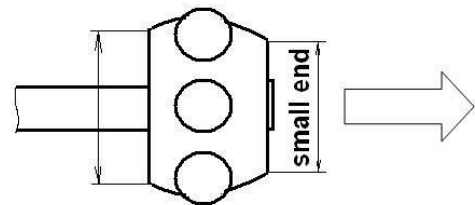
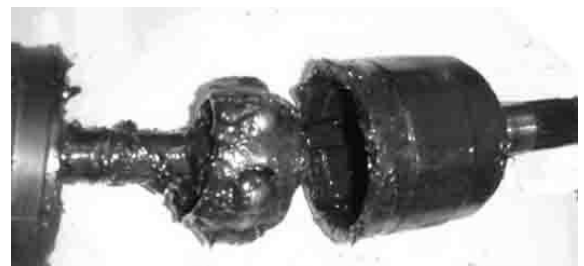

CAUTION: It is critical to avoid undue stress on the rubber boots after the drive axle is installed and the vehicle is run. Don't twist the boot, and always set the both ends in designed position.

16. Secure all large boot bands. Bend down the tab on the boot band and secure the tab with the locking clip and tap them with a plastic hammer. Make sure they are locked in place.
17. If removed, install the stopper ring and make sure it is seated correctly in the drive axle groove.
18. Apply molybdenum disulfide grease to the end splines.

5.10 REAR HUB EXPLODED VIEW

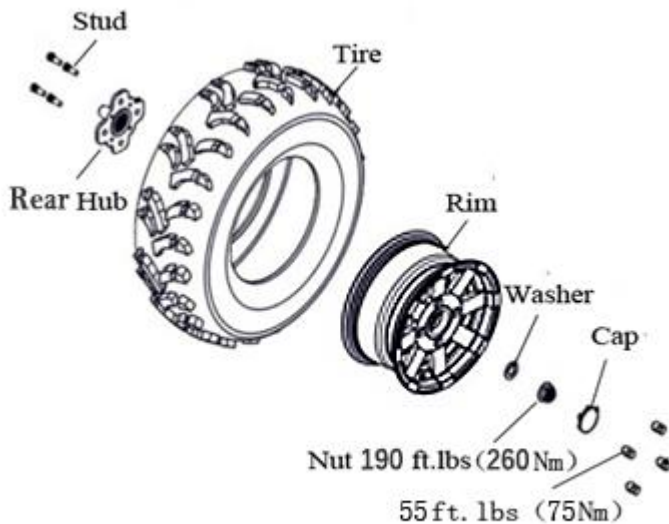

5.11 REAR HUB AND KNUCKLE REMOVAL/INSPECTION

1. Elevate rear end and safely support machine under main frame area.

CAUTION: Serious injury may result if machine tips or falls. Be sure machine is secure before beginning this service procedure. Wear eye protection when removing bearings and seals.

2. Check bearings for side play by grasping the tire/Wheel firmly and checking for movement. Grasp the top and bottom of the tire. The tire should rotate smoothly without binding or rough spots.
3. Remove wheel nuts and wheel.

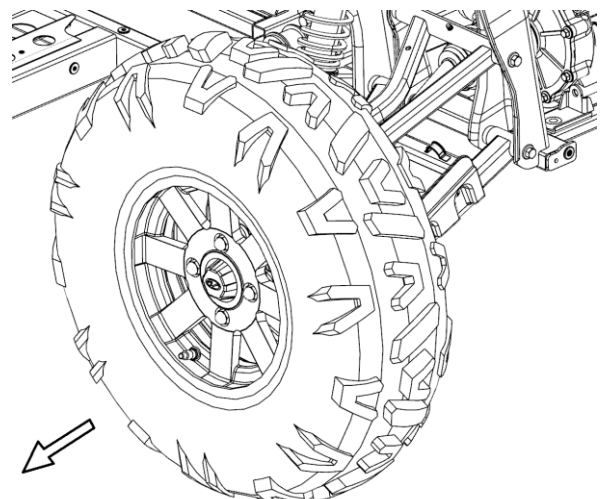

4. Remove the two brake caliper attaching bolts.
- CAUTION:** Do not hang the caliper by the brake line. Use wire to hang the caliper to prevent possible damage to the brake line.
5. Remove rear spindle nut and washer.
 6. Remove the upper and lower control arm bolts.
 7. Slide the rear hub and knuckle from the rear drive shaft.
 8. Inspect the rear hub and knuckle assembly by hand for smoothness and side to side movement, replace as needed.

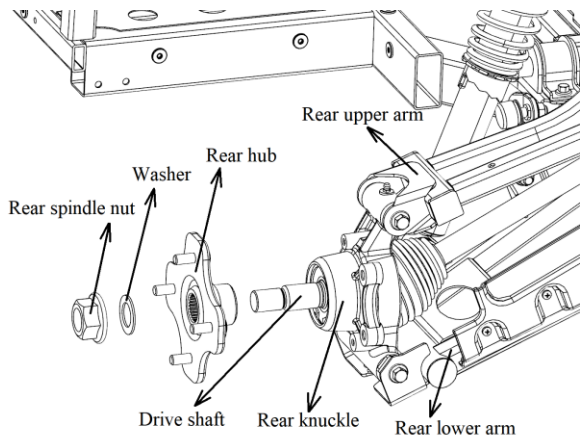

5.12 REAR HUB AND KNUCKLE INSTALLATION

1. Start the rear hub and knuckle assembly onto the drive shaft.
 2. Align the bottom of knuckle and lower control arm. Secure with the lower control arm bolt.
 3. With the driveshaft placed in the knuckle, align the knuckle with the top control arm. Secure with the upper control arm bolt.
-
4. Torque the top and bottom A-arm bolts as shown in the photo.
-
5. Install the washer and the new spindle nut.
 6. Lower the vehicle. Torque the spindle nut to 190 ft.lbs. (260 Nm).
 7. Knock on the edge of the spindle nut, so that it can be clamped into the limit slot.
 8. Install brake caliper using new bolts. (Apply Loctite™ 243 to threads) Tighten bolts to 18 ft.lbs (25 Nm).
 9. Install the wheel and wheel nuts. Torque wheel nuts to 55 ft.lbs. (75 Nm).

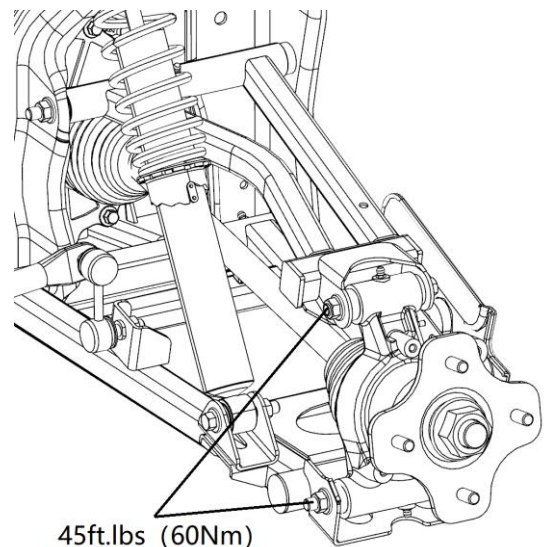
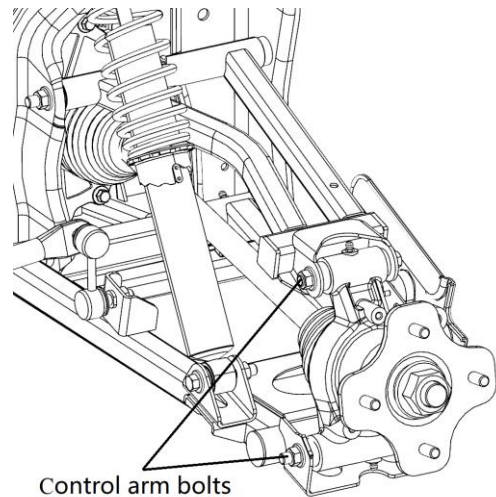

5.13 REAR DRIVE SHAFT REMOVAL

1. Repeat of the steps in the “REAR HUB AND KNUCKLE REMOVAL” section.
2. Slide the rear drive shaft out of the knuckle by pulling the hub and knuckle assembly outward and down.
3. Pull the rear drive shaft straight out of the rear gearcase. Use short sharp jerks to free the circlip from the gearcase. The circlip holds the shaft in the gearcase.
4. Inspect the shaft splines and CV boots for any damage.

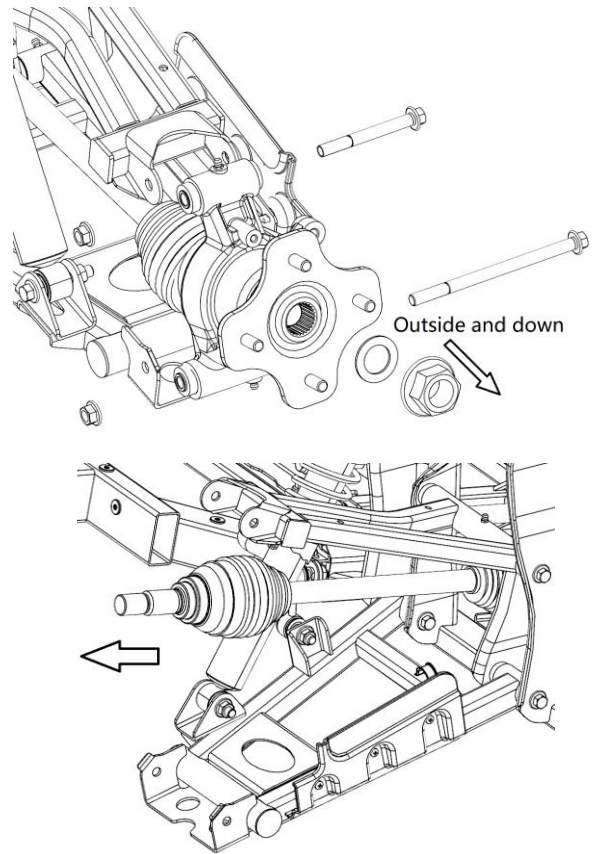

5.14 REAR DRIVE SHAFT INSTALLATION

1. Install a new circlip on the rear drive shaft. Apply lubricating grease (Anti-Seize Compound) to the rear drive shaft splines (both ends).
2. Reinstall the rear drive shaft into the rear gearcase. Be sure the circlip is securely fit into the rear gearcase. Use a rubber mallet to tap on the outboard end of the driveshaft if necessary.

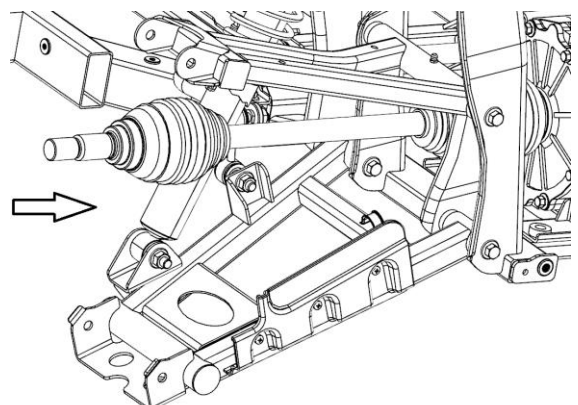
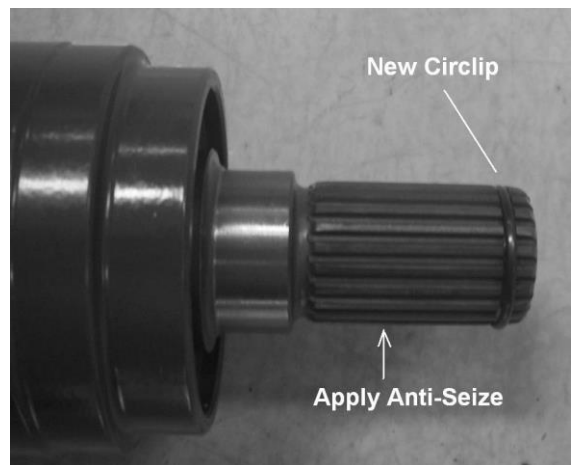

3. Slide the rear drive axle into the knuckle.
4. Lift knuckle into place and install bolts to the upper and lower control arms. Torque bolts to 45 ft.lbs (60 Nm).
5. Install the washer and the new spindle nut.
6. Lower the vehicle. Torque the spindle retaining nut to 103 ft.lbs. (140 Nm).
7. Knock on the edge of the spindle nut, so that it can be clamped into the limit slot.
8. Install brake caliper using new bolts. (Apply Loctite™ 243 to threads) Tighten bolts to 18 ft.lbs (25 Nm)
9. Install the wheel and wheel nuts. Torque wheel nuts to 55ft.lbs. (75 Nm).

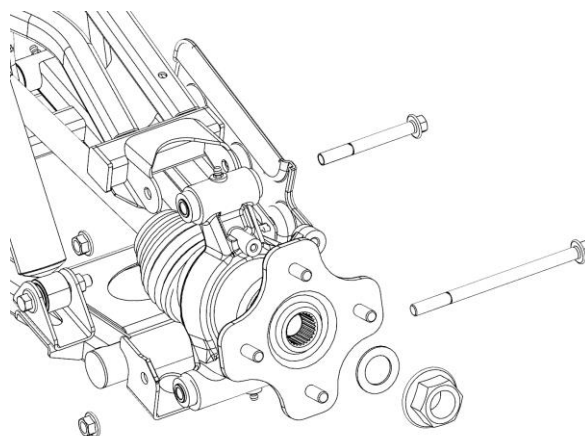

5.15 REAR GEARCASE EXPLODED VIEW

REAR GEARCASE EXPLODED VIEW

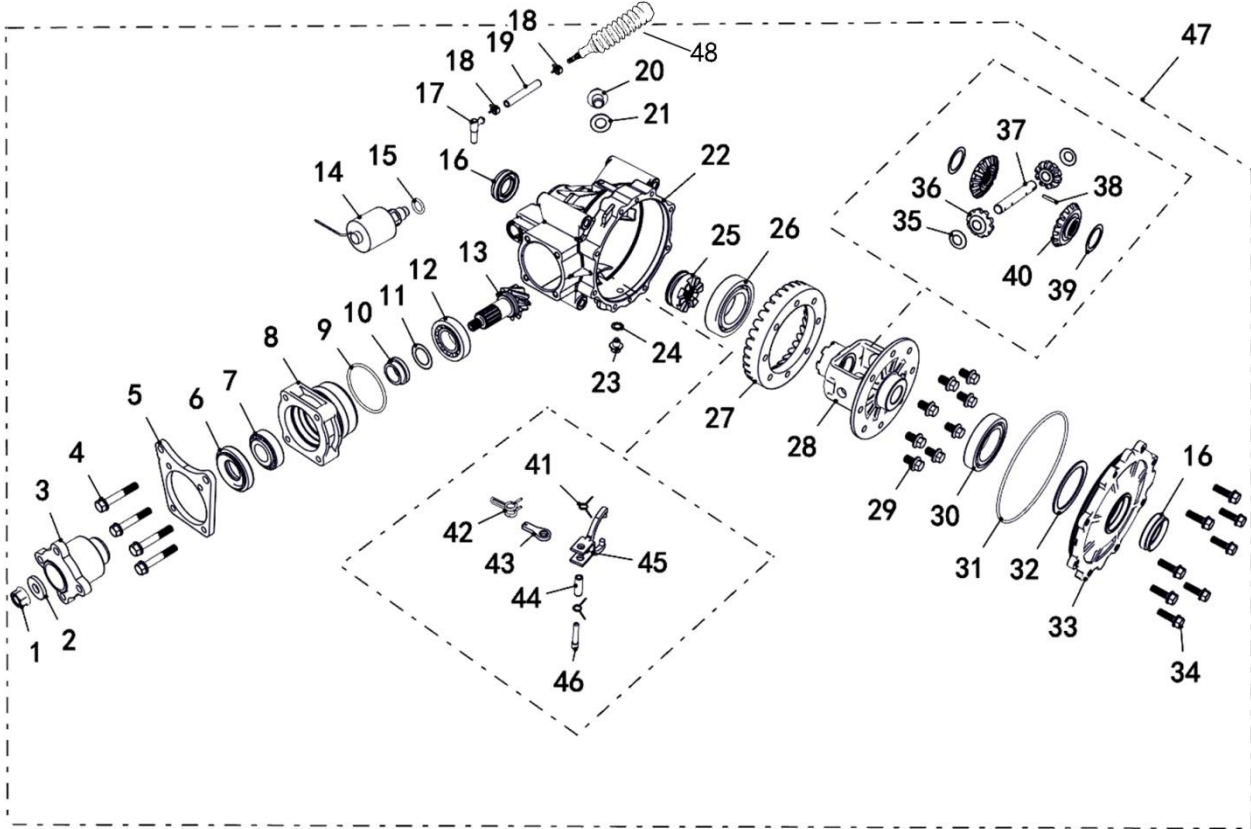

1	Nut, Rear Output Shaft	1	25	Clutch Gear	1
2	Washer, Rear Output Shaft Nut	1	26	Bearing 6210	1
3	Coupler, Rear Axle	1	27	Bevel Gear -Driven	1
4	Bolt M8×50	4	28	Diff Case	1
5	Mount Bracket-Parking Braking	1	29	Hexagon Flange Bolt M10×1.25×16	8
6	Oil Seal 35×61×9	1	30	Bearing 110	1
7	Bearing 30205	1	31	O-Ring 151×3	1
8	Bevel Gear Bearing Housing	1	32	Adjusting Shim	AR
9	O-Ring 69×3	1	33	Rear Axle Box Cover	1
10	Bearing Sleeve	AR	34	Bolt M8×25	8
11	Adjusting Shim,Bevel Gear -Driving	1	35	Wearing Ring	2
12	Bearing 30206	1	36	Planetary Gear	2
13	Bevel Gear -Driving	1	37	Gear Shaft	1
14	Diff Solenoid	1	38	Pin 4×30	1
15	O-Ring 17×3	1	39	Side Gear Thrust-Washer	2
16	Oil Seal 30×50×13.5	2	40	Diff Side Gear	2
17	Vent Nozzle	1	41	Shift Return Spring	2
18	Clip	2	42	Shift Lever Spring	1
19	Vent Pipe	1	43	Shift Lever	1
20	Bolt M18×1.25	1	44	Shift Bar	1
21	Washer 18	1	45	Shift Yoke	1
22	Gear Case,Rear Axle	1	46	Shift Pin	1
23	Drain Plug	1	47	Rear gearcase	1
24	Washer	1	48	Breathing airbag	1

5.16 REAR GEARCASE DISASSEMBLY

Important: Before starting any operation on the gearbox, make sure that never clean the gearbox with a high pressure water jet.

The pinion gear assembly (A) is NOT intended to be disassembled from the case, as it requires special tooling in order to properly reassemble. If there is any damage to the pinion gear, bearings or case, the assembly must be replaced. Pinion and ring gear shimming information is NOT provided due to manufacturing requirement.

- 1.remove the breathing airbag(NO.48).
→Fig 0

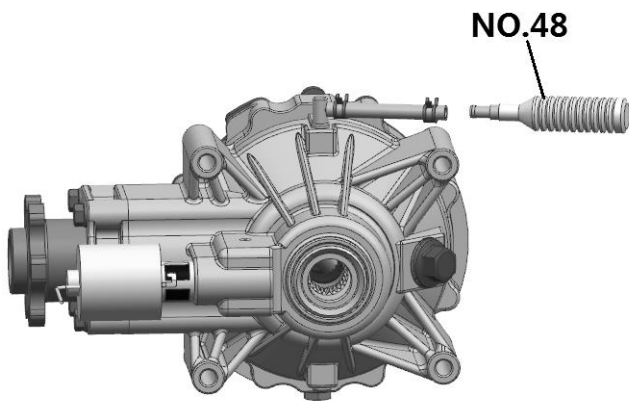

Fig 0

- 2.Remove the oil drain plug (NO.23) and let the oil drain from the gearbox.

Important: Clean the plug carefully. Replace the sealing washer (NO.24) before it's assembled. →Fig 1

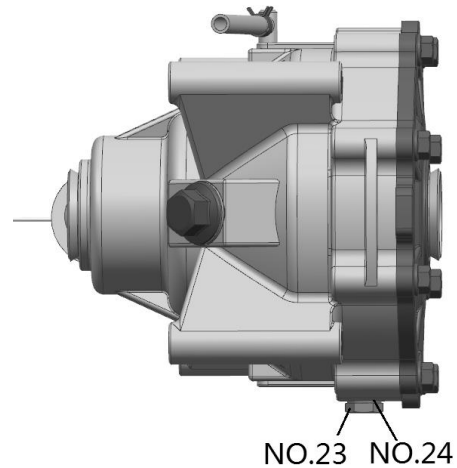

Fig 1

- 3.Remove the differential solenoid (NO.14) from the gearcase cover if servicing the solenoid, shift lever, shift lever spring, or shift yoke. If none of these items are being serviced. The solenoid can remain installed in the gearcase cover. →Fig 1

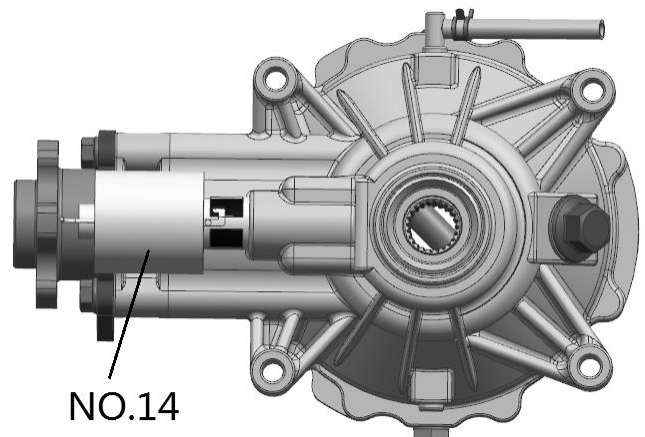

Fig 2

- 4.Remove the Bolts M8×50 (NO.4), Remove assembly (A). →Fig 3

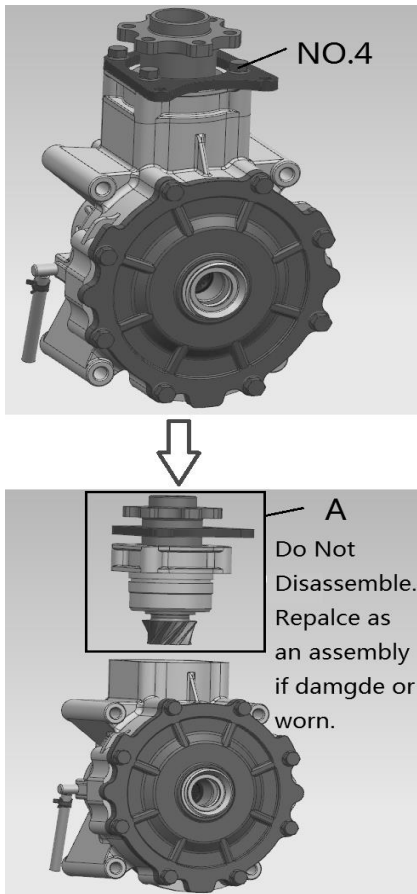

Fig 3

5.Remove Bolts M8×25 (NO.34) that secure the housing. →Fig 4

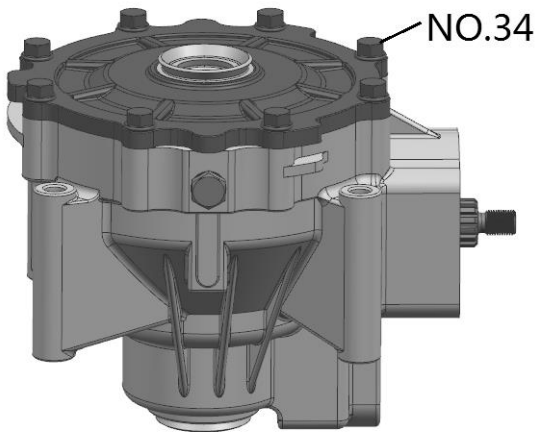

Fig 4

6.Remove the differential assembly (B) from the housing.. →Fig 5

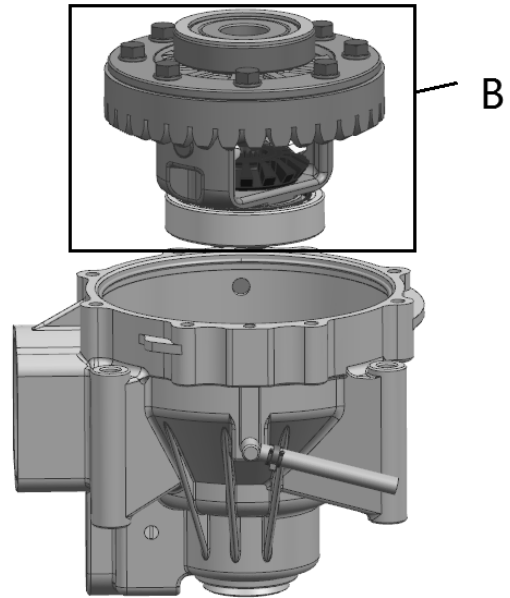

Fig 5

7.Remove the shims from the differential assembly. Be sure to keep the shims together for reassembly. →Fig 6

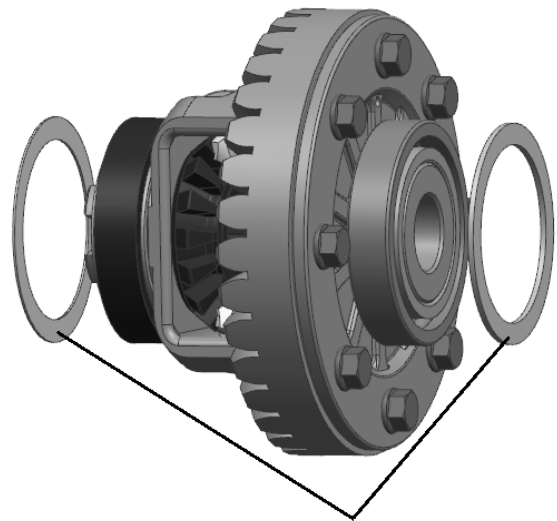

Fig 6

8.Inspect the bevel gear for chipped, worn, or broken teeth.

Important: Do not disassemble the differential assembly (B). Replace as an assembly if damaged or worn. →Fig 7

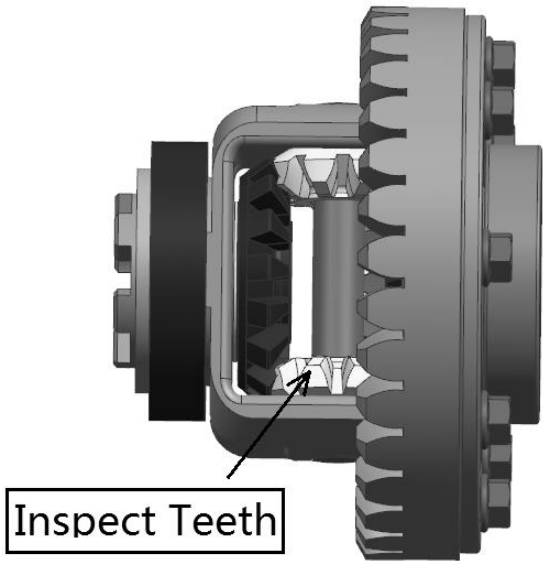

Fig 7

NOTE: The PINION GEAR ASSY (A) AND THE DIFFERENTIAL ASSEMBLY (B) MUST BE REPLACED SIMULTANEOUSLY,NOT SEPARATELY.

9.Remove the clutch gear (NO.25) from the gearcase cover. →Fig 8

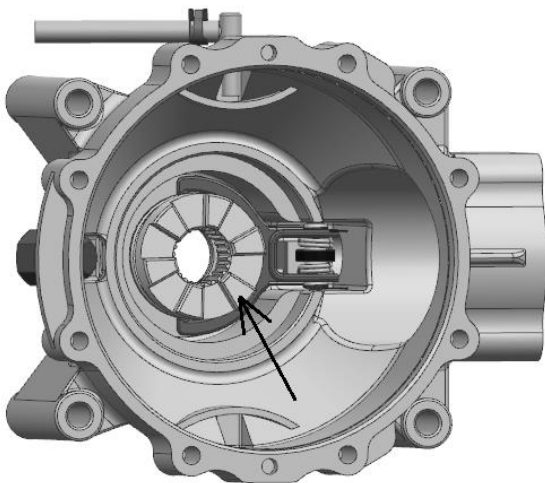

Fig 8

10.Inspect the shift lever (NO.43), shift level spring (NO.42), shift return spring (NO.41), and shift yoke (NO.45) for excessive wear or damage. If disassembly is required proceed to the next step. If no disassembly is required

proceed to “Rear Gearcase Assembly.” →Fig 9

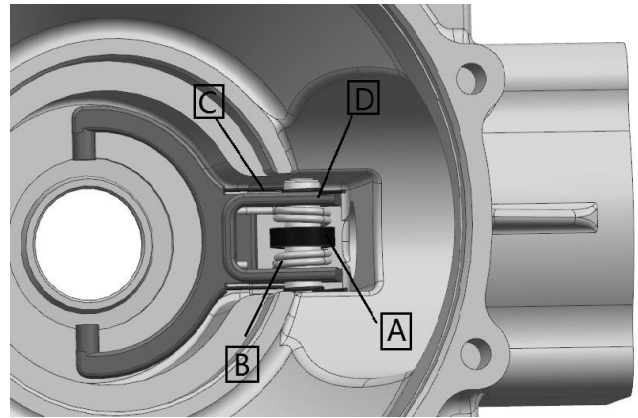

Fig 9

11.Loosen the lock shift pin (NO.46). →Fig 10

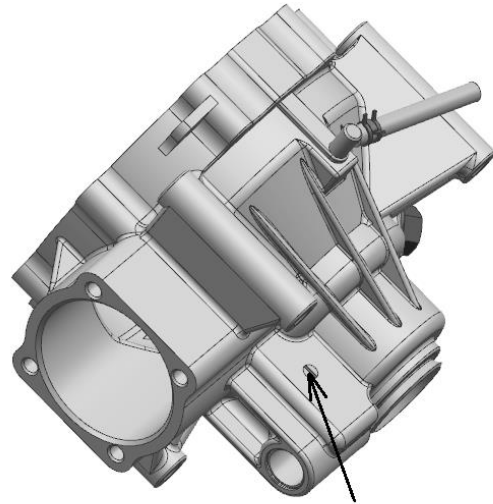

Fig 10

12.Remove the pin from the gearcase cover. →Fig 11

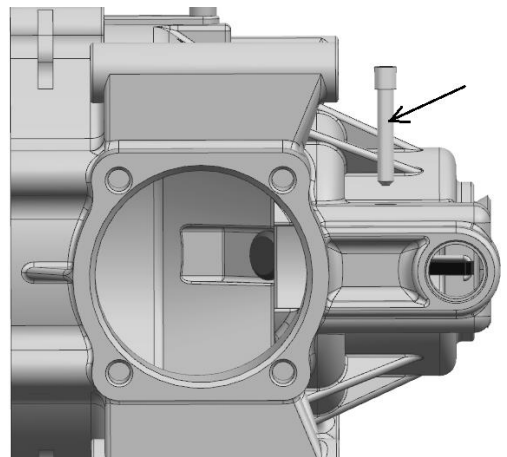

Fig 11

13. Carefully remove the shift yoke assembly from the gearcase cover. → Fig 12

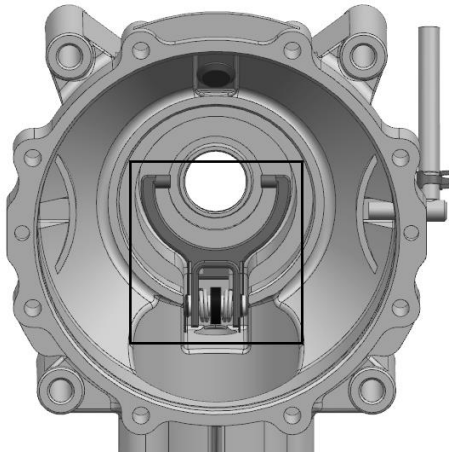
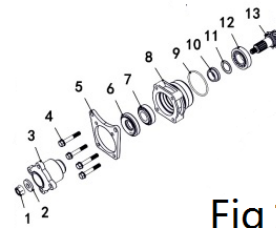

Fig 12

intend to be disassembled from the case, as it requires special tooling in order to properly reassemble. If there is any damage to the pinion gear, bearings or case, the assembly must be replaced. → Fig 14



Do Not Disassemble
Replace as an assembly if damaged or worn

Fig 14

14. Inspect the shift lever (NO.43), shift level spring (NO.42), shift return spring (NO.41), shift yoke (NO.45), and lock shift bar (NO.44). Inspect the components for excessive wear or damage and replace as needed. → Fig 13

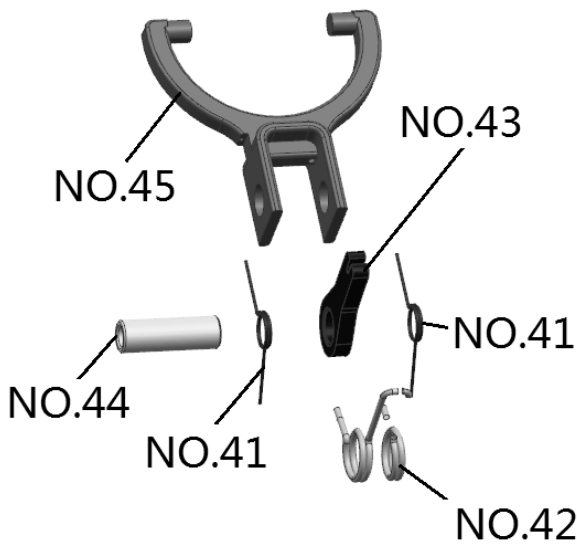

Fig 13

2. Replace the Oil Seal 30×50×13.5 (NO.16) located in the main gearcase and gearcase cover → Fig 15

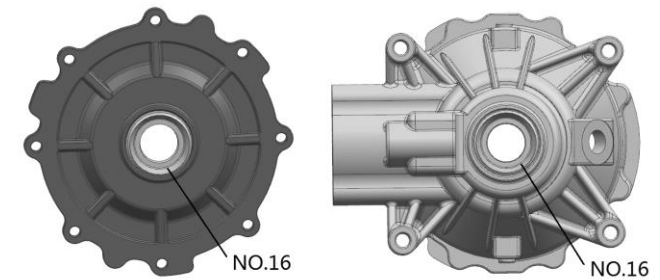

Fig 15

- 3. Replace all worn components.
- 4. If previously removed; assemble the shaft lever, shift lever spring, shift return springs, shift yoke, and lock pin bushing. → Fig 13
- 5. Carefully install the shift yoke assembly into the gearcase cover. → Fig 12
- 6. Install the lock shift (NO.46) pin and tighten. → Fig 11
- 7. Install the clutch gear (NO.25) and the original shims into the gearcase. → Fig 16

5.17 REAR GEARCASE ASSEMBLY

Important: Before starting any operation on the gearbox, to ensure that the surface of all parts is clean.

1.NOTE: The pinion gear assembly is NOT

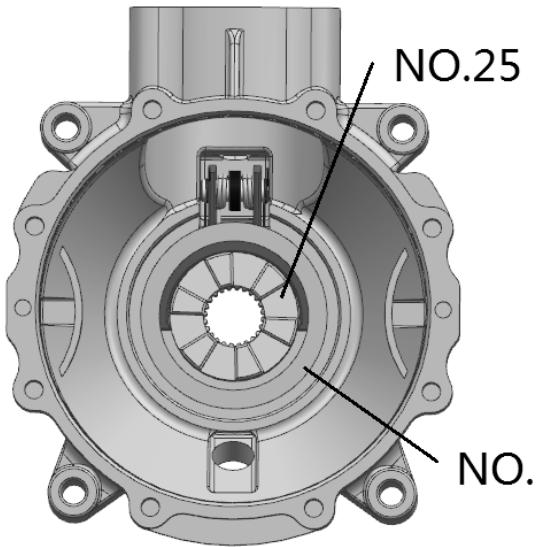

Fig 16

8. Install the differential assembly into the carrier housing. → Fig 17

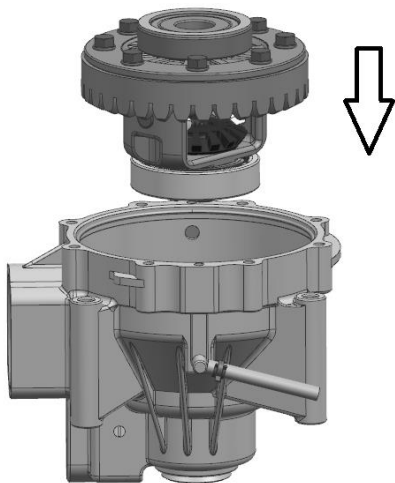

Fig 17

9. Install the original shims (NO.32) and the new O-ring (NO.31) onto the Rear Axle Box Cover (NO.33), then assemble the Rear Axle Box Cover (NO.33) and install the bolts that secure the cover to the housing. Torque the bolts in a criss cross pattern to **25-30Nm**. → Fig 18

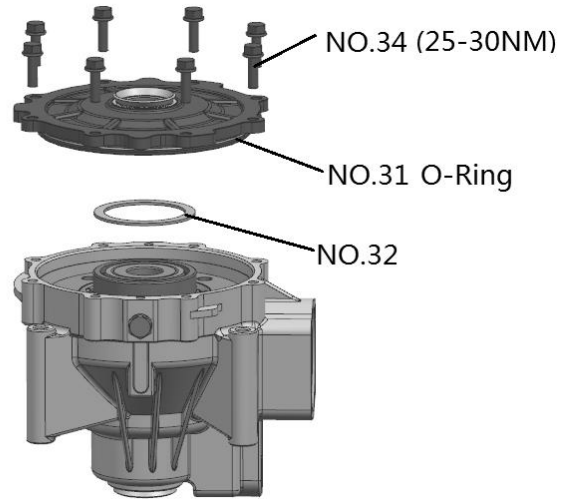

Fig 18

10. Install the pinion gear assembly. Torque the bolts in a criss cross pattern to **25-30Nm**. → Fig 19

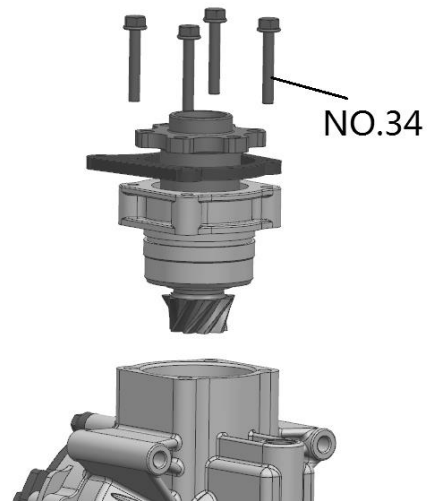

Fig 19

11. If previously removed, install the Diff Solenoid (NO.14) into the carrier cover. Torque solenoid to **40-55Nm**. → Fig 20

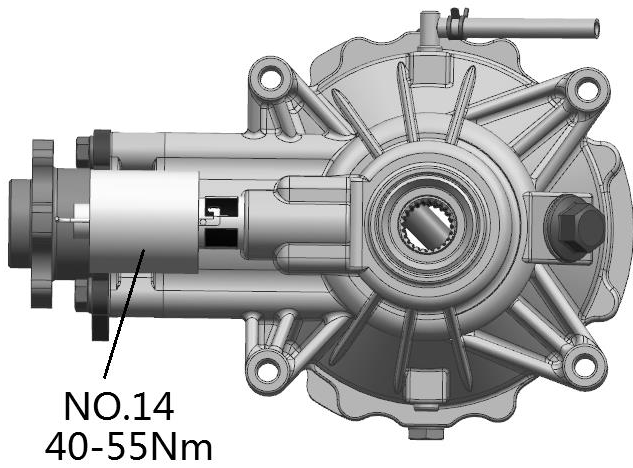

Fig20

12. Mount the oil drain bolt (NO.23) and washer (NO.24). Add $250 \pm 25\text{mL}$ oil(85W/90GL-4). Fig 21

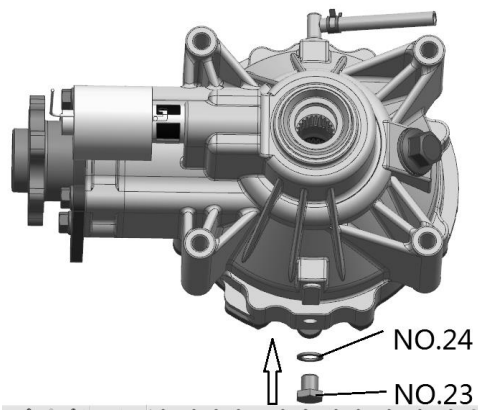

Fig21

13. Assemble the breath airbag(NO.48).
→ Fig 22

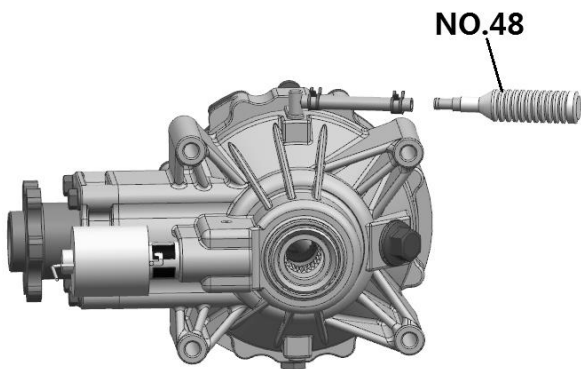
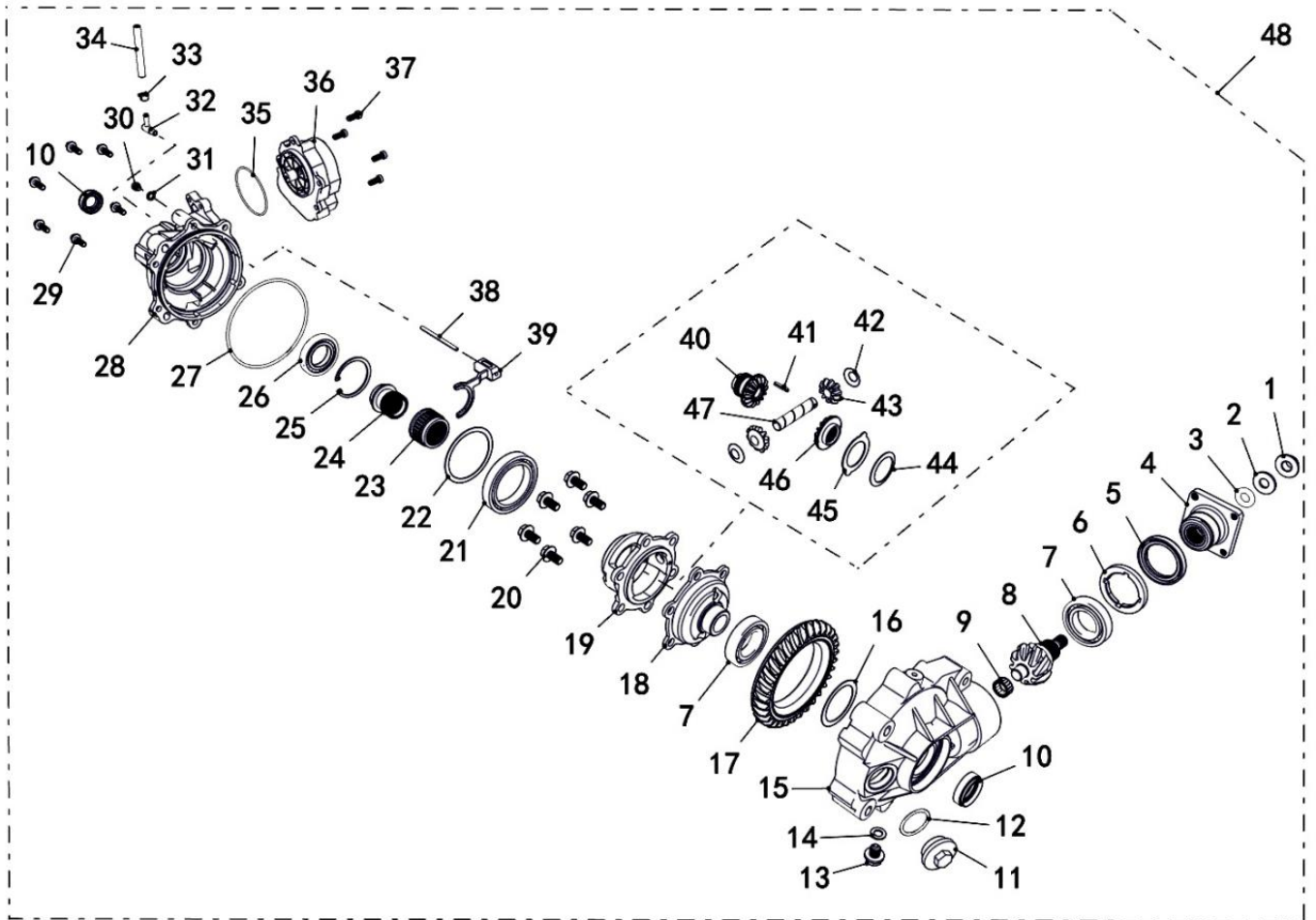

Fig22

5.18 FRONT GEARCASE EXPLODED VIEW

FRONT GEARCASE EXPLODED VIEW



1	Nut, Front Output Shaft	1	26	Bearing 16007	1
2	Washer, Front Output Shaft Nut	1	27	O-Ring 141×2.4	1
3	O-Ring	1	28	Gear Case, Front Axle	1
4	Coupler, Front Axle	1	29	Bolt M8×25	6
5	Oil Seal 48×65×9	1	30	Screw M8×8	1
6	Bearing Retainer	1	31	Washer 8	1
7	Bearing 6007	2	32	Vent Nozzle	1
8	Bevel Gear -Driving	1	33	Clip	1
9	Needle Bearing	1	34	Vent Pipe	1
10	Oil Seal 24×38×8	2	35	O-Ring 81.2×1.9	1
11	Fill Plug	1	36	Gear Motor	1
12	O-Ring 30.5×3	1	37	Screw M8×20	4
13	Drain Bolt	1	38	Pin Shaft	1
14	Washer 10	1	39	Shift Fork	1
15	Front Axle Box Cover	1	40	Drive Gear	1
16	Adjusting Shim(61×48)	as needed	41	Pin 5×25	1
17	Bevel Gear -Driven	1	42	Wearing Ring	2
18	Top Bracket,Differential Gear	1	43	Gear(Center), Differential	2
19	Bracket,Differential	1	44	Washer	1
20	Bolt M10×1.25×20	6	45	Shim	1
21	Bearing 61912	1	46	Driven Gear	1
22	Adjusting Shim(83×71)	as needed	47	Gear Shaft	1
23	Drive Clutch	1	48	Front Axle	1
24	Drive Clutch Cover	1	49		
25	Circlip 62	1	50		

5.19 FRONT GEARCASE DISASSEMBLY

Important: Before starting any operation On the gearbox make sure GEAR MOTOR (NO.36) is protected (if mounted). Never clean the gearbox with a high pressure water jet.
→Fig 0.

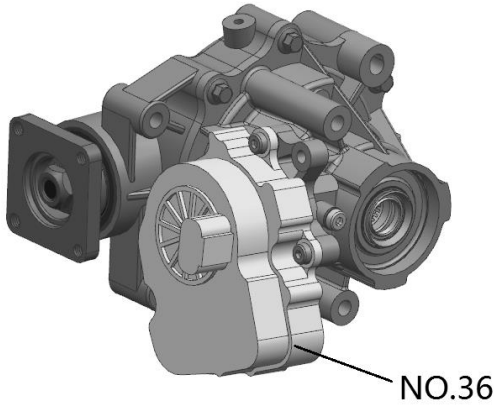

Fig 0

1. Remove the DRAIN BOLT (NO.13) and let the oil drain from the gearbox.

Important: Clean the plug carefully and Replace WASHER 10 (NO.14) before Its assembled. →Fig 1.

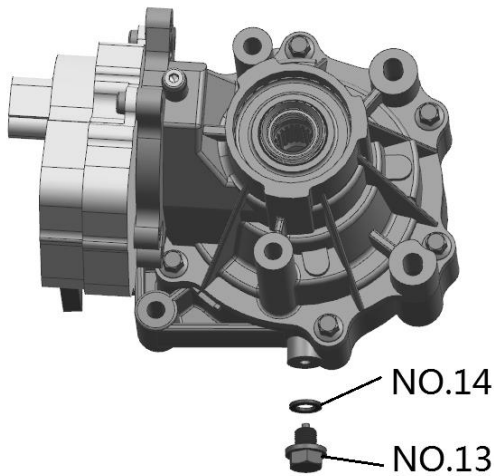

Fig 1

2. Remove the NUT (NO.1) and the washer (NO.2).
→Fig 2

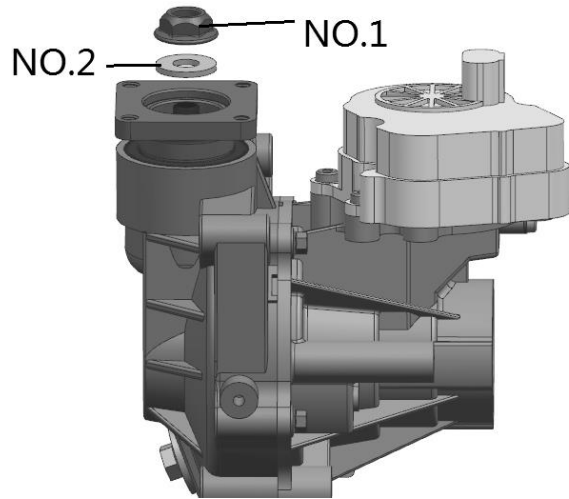

Fig 2

3. Remove the O-RING (NO.3) .
→Fig 3.

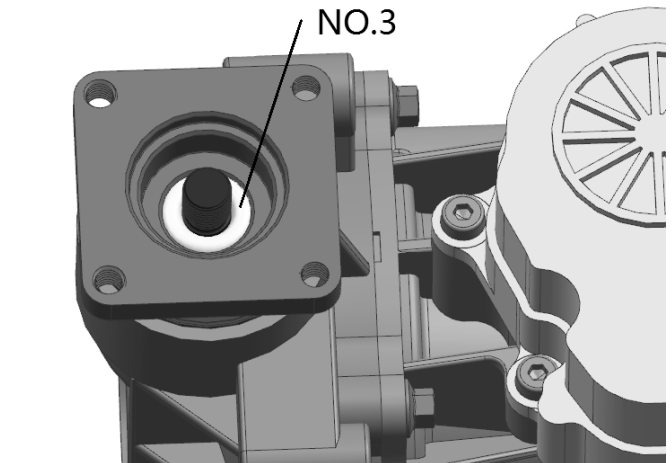

Fig 3

4. Remove the COUPLER (NO.4).
→Fig 4.

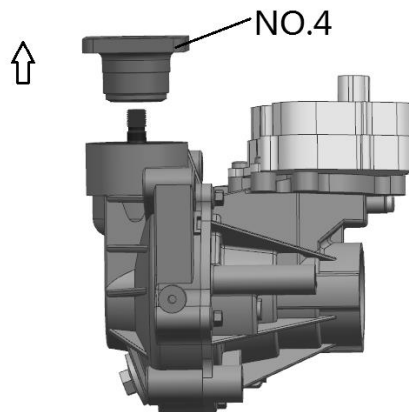

Fig 4

- 5. Remove the OIL SEAL (NO.5) and replace with a new seal.
→Fig 5.

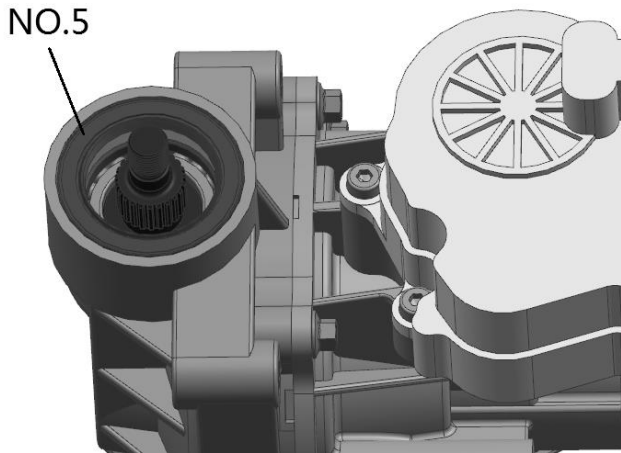

Fig 5

- 6. Remove the four SCREW (NO.37).
→Fig 6.

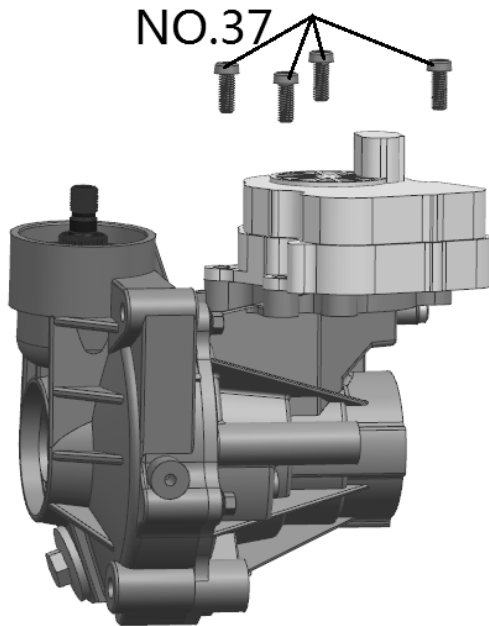

Fig 6

- 7. Remove the GEAR MOTOR (NO.36).
→Fig 7.

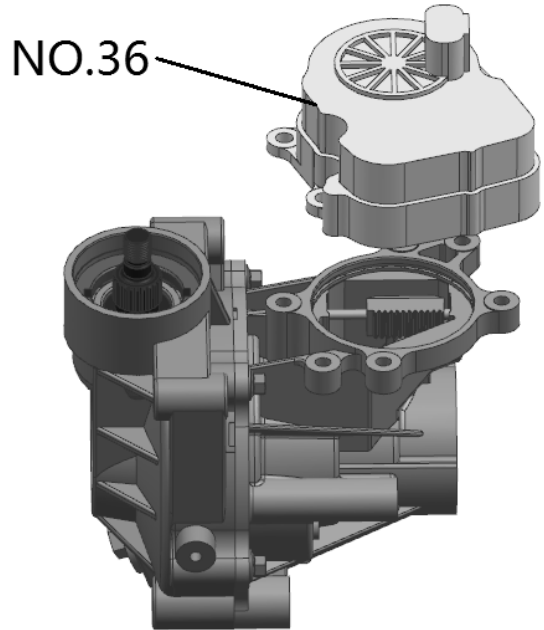

Fig 7

- 8. Remove the six bolts M8 X L28 (NO.29).
→Fig 8.

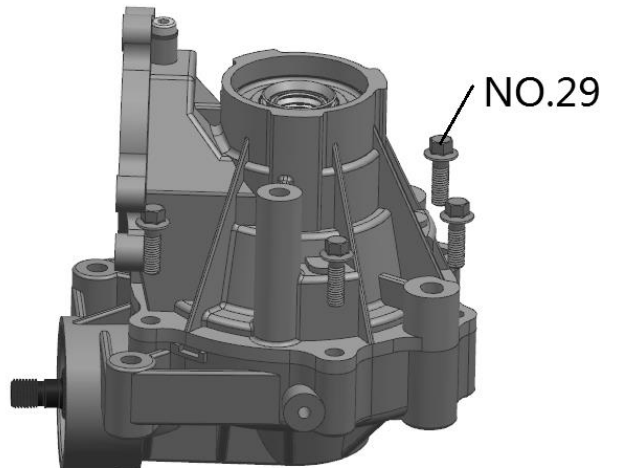

Fig 8

- 9. Remove the GEAR CASE ASSY, FRONT AXLE (NO.28) and CASE COVER ASSY, FRONT AXLE (NO.15).
→Fig 9.

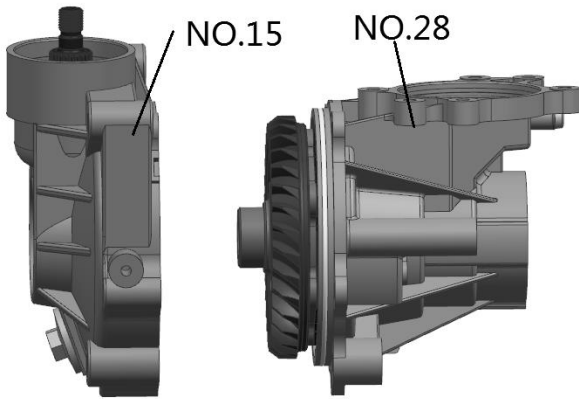

Fig 9

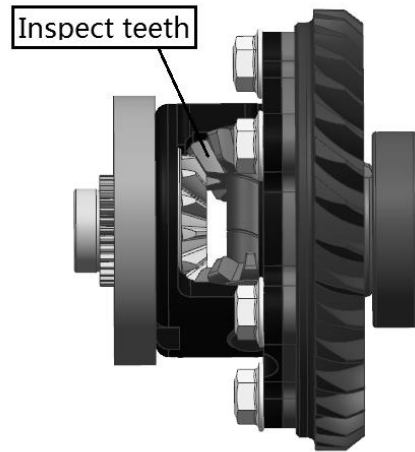

Fig 11

10. Remove the DIFFERENTIAL GEAR ASSY **A** from the housing.
→Fig 10

12. Remove the shims from the differential assembly. Be sure to keep the shims together for reassembly.
→Fig 12.

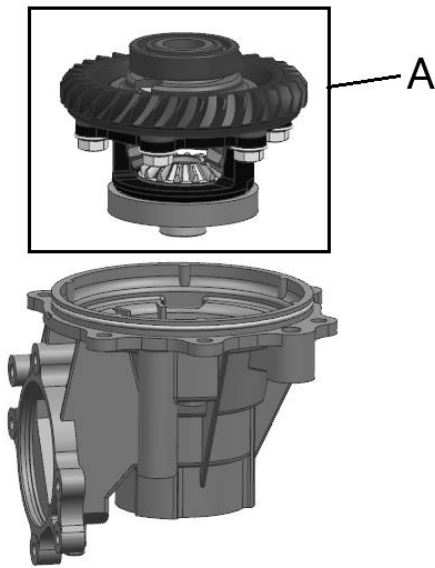

Fig 10

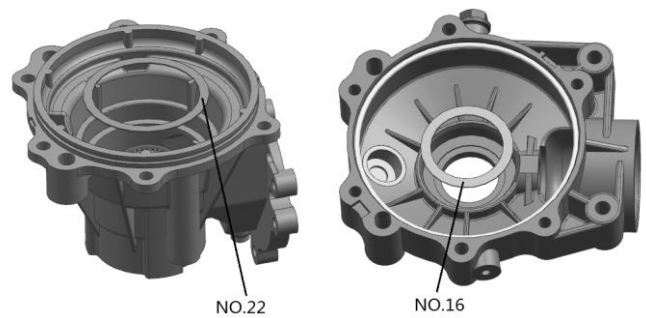

Fig 12

11. Inspect the bevel gear for chipped, worn or broken teeth.

NOTE: The DIFFERENTIAL GEAR ASSY (A) is NOT intended to be disassembled, as it requires special tooling in order to properly reassemble. If there is any damage to the gear, bearings or others, the assembly must be replaced.

→Fig 11

12. Remove the SCREW (NO.30) and the WASHER (NO.31).
→Fig 13.

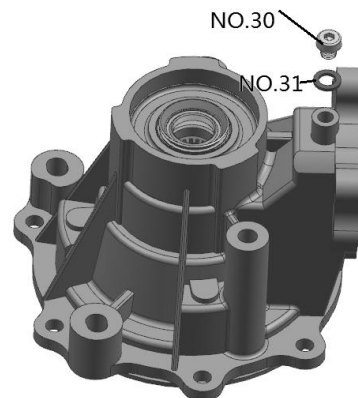

Fig 13

13. Remove the PIN SHAFT (NO.38), SHIFT FORK (NO.39).
→Fig 14

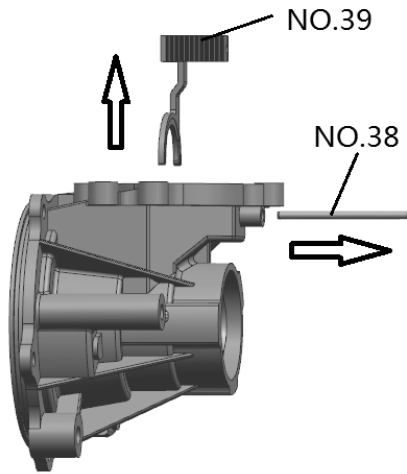

Fig 14

14. Remove the DRIVE CLUTCH (NO.23).
→Fig 15.

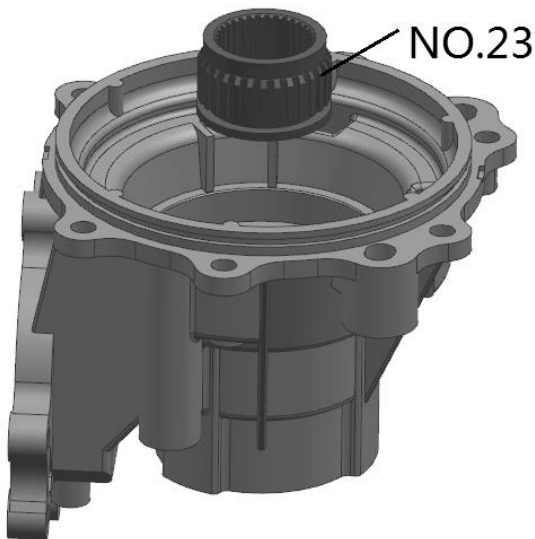

Fig 15

15. Inspect the bearing (NO.26). If the bearing was damaged, remove the RETAINER (NO.25) first, and then remove the bearing (NO.26).
→Fig 16.

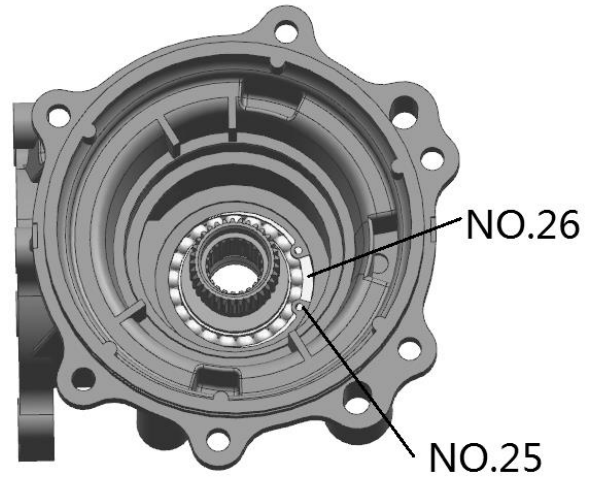

Fig 16

16. Remove the DRIVE CLUTCH COVER (NO.24).
→Fig 17.

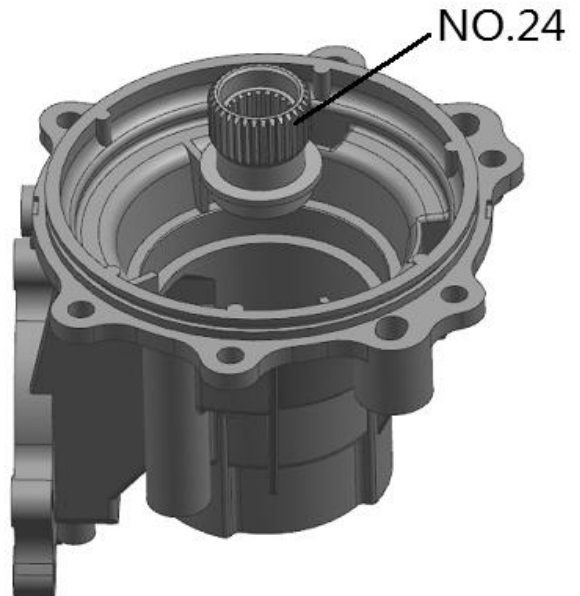

Fig 17

18. Remove the OIL SEAL (NO.5).
→Fig 18.

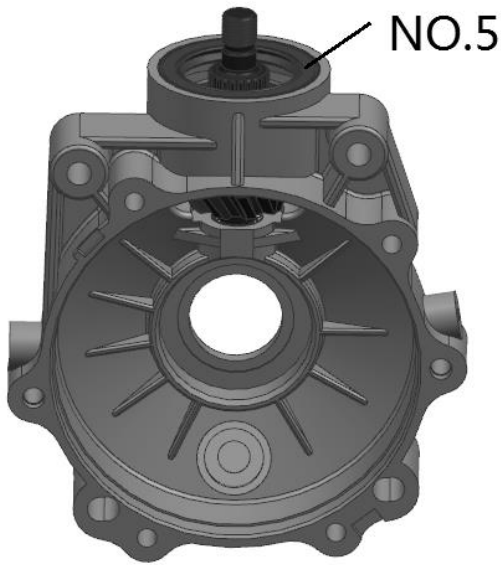

Fig 18

19. Remove the BEARING RETAINER (NO.6) with special tool.
→Fig 19.

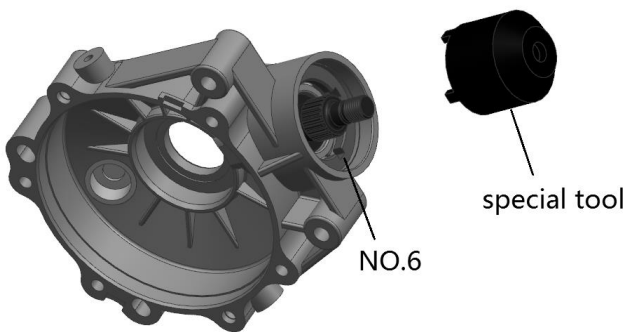

Fig 19

20. Remove the DRIVE PINION GEAR B.
→Fig 20.

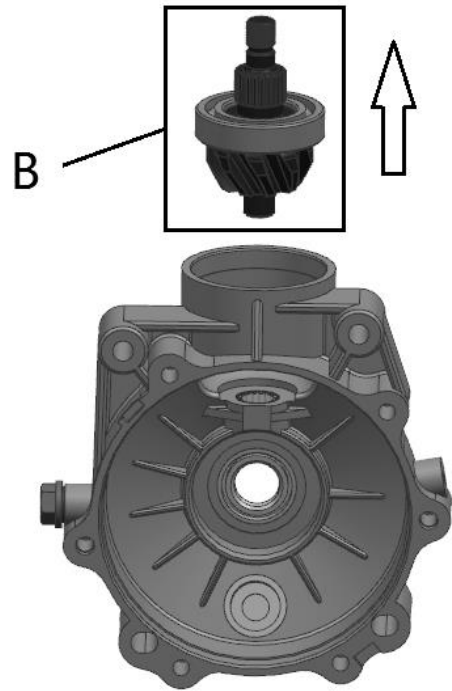

Fig 20

NOTE: The DIFFERENTIAL GEAR ASSY (A) AND THE DRIVE PINION GEAR B MUST BE REPLACED SIMULTANEOUSLY, NOT SEPARAT

5.20 FRONT GEARCASE ASSEMBLY

Note: Grease all seals and O-rings with all season Grease upon assembly

1. Mount the drive clutch cover (NO.24).
→Fig 1

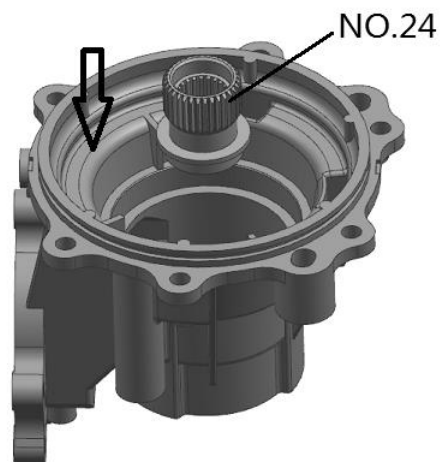

Fig 1

2. Mount the retainer 62 (NO.25) .
→Fig 2.

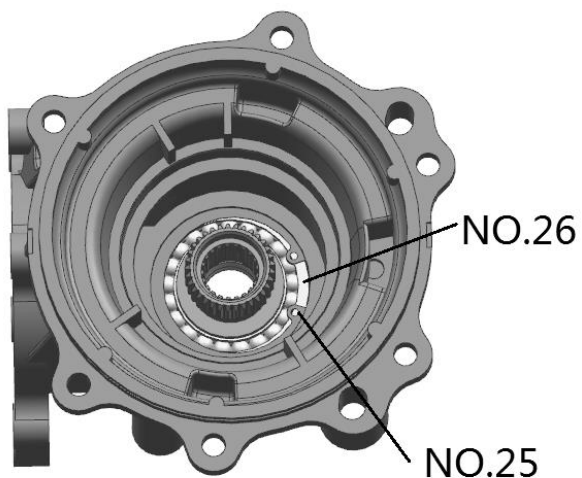

Fig 2

3. Mount the drive clutch (NO.23).
→Fig3.

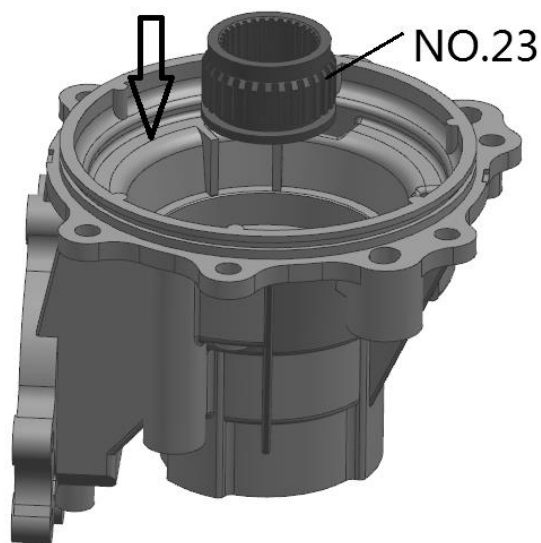

Fig 3

4. Mount the pin shaft (NO.38) and the shift fork (NO.39) .
→Fig 4.

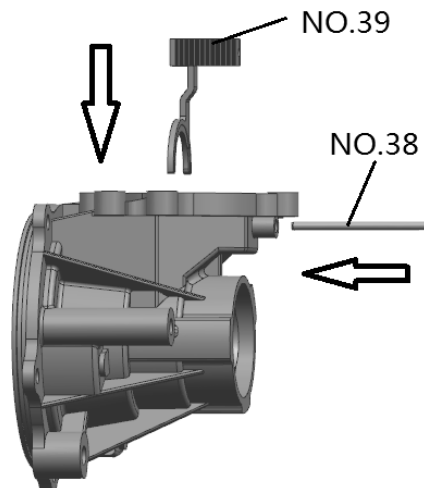

Fig 4

5. Install the screw (NO.30) and washer (NO.29), then mount the screw (NO.30) .
→Fig 5.

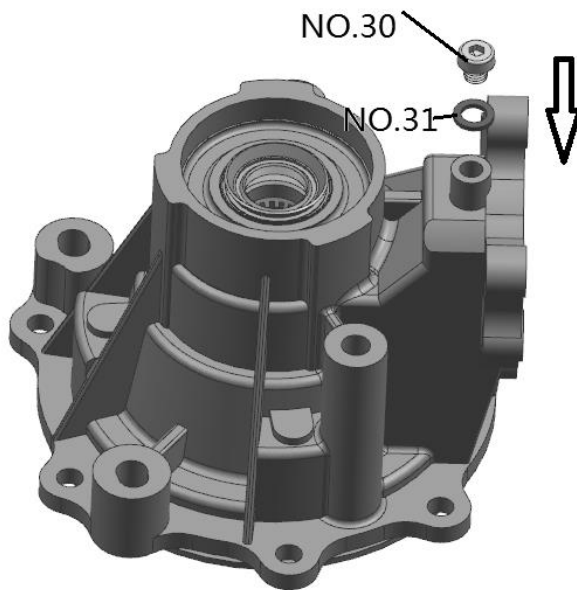

Fig 5

6. Mount the adjust shim (NO.22).
→Fig 6.

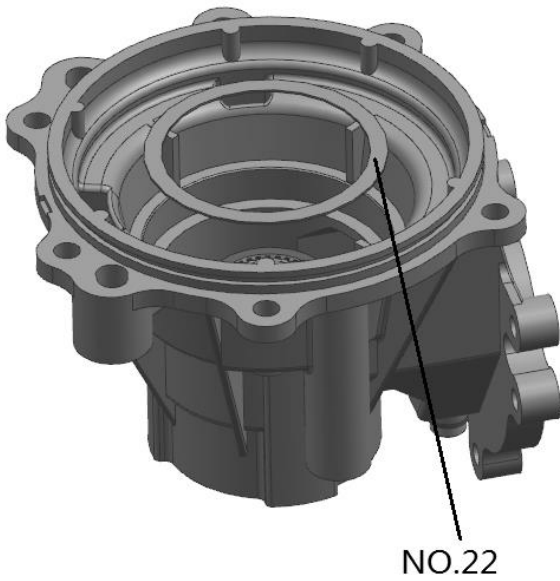

Fig 6

7. Install the DIFFERENTIAL GEAR ASSY **A** into the carrier housing.
→Fig 7

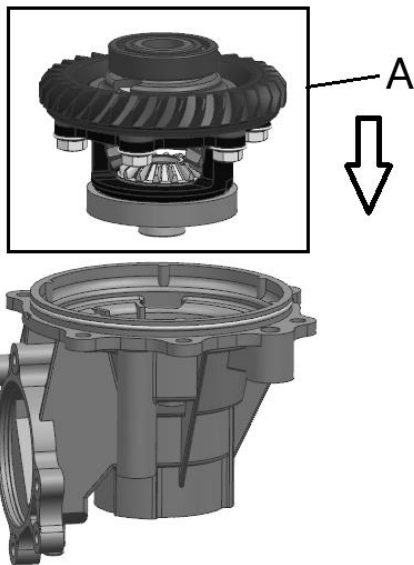

Fig 7

8. Install the DRIVE PINION GEAR **B** and install the BEARING RETAINER (NO.6) with special tool
→Fig 8.

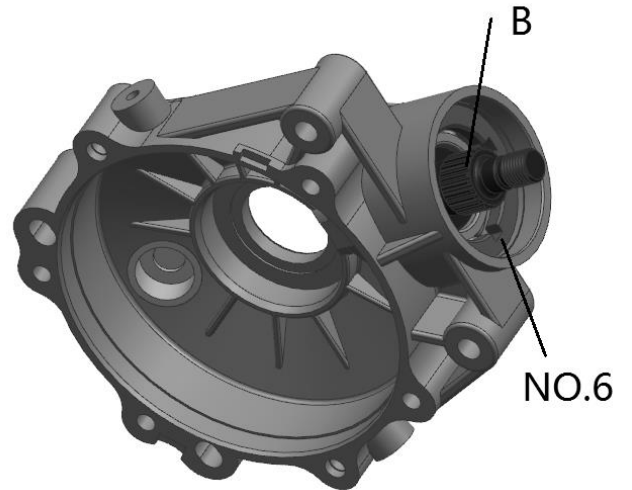

Fig 8

9. Install a new OIL SEAL (NO.5)
→Fig 9

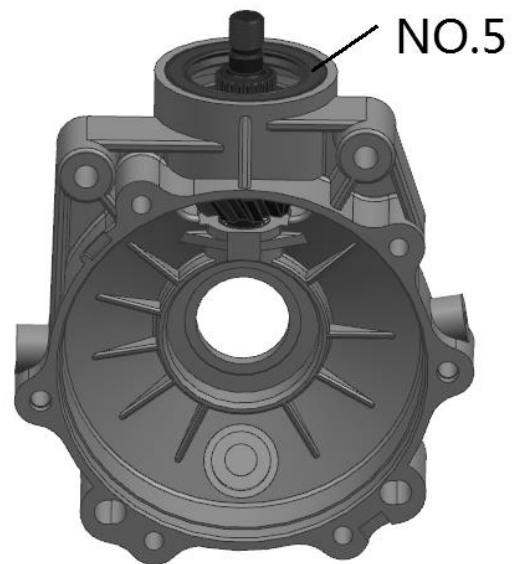

Fig 9

10. Mount the adjust shim (NO.16).
→Fig 10

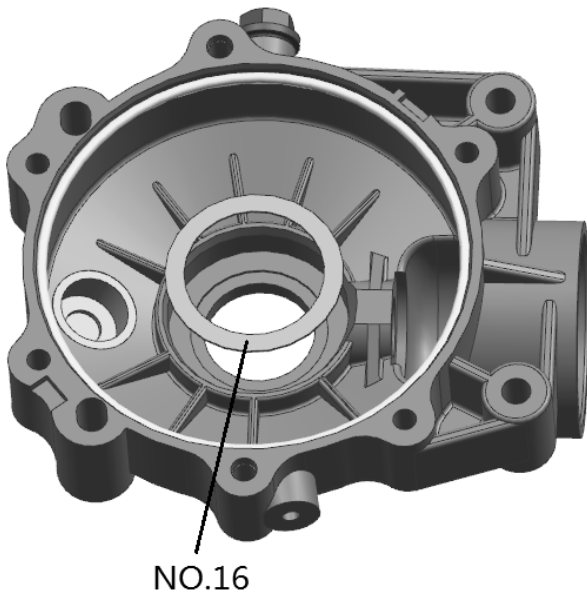

Fig 10

11. Assemble the gearcase halves and install the bolts (NO.29) that secure the cover to the housing. Torque the bolts in a criss cross pattern to 20~25Nm. →Fig 11

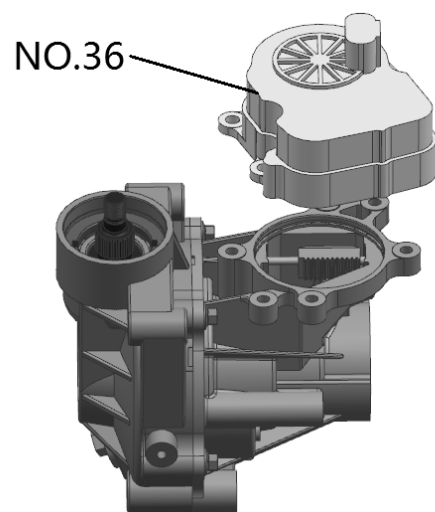
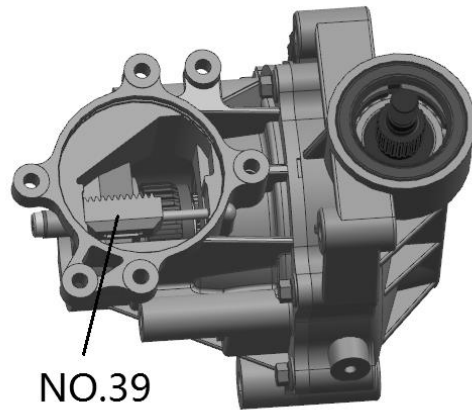

Fig 12

13. Mount the four screws (NO.37) .
→Fig 13.

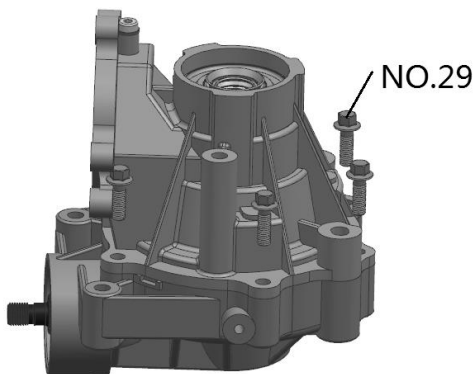

Fig 11

12. Mount the gear motor A.

Important: Before assemble the gear motor (NO.36), make sure that the shift fork (NO.39) is in their correct position as shown.

→Fig 12.

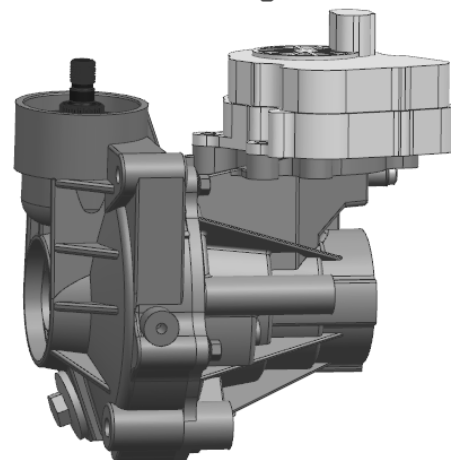

Fig 13

14. Mount the coupler (NO.4).
→Fig 14

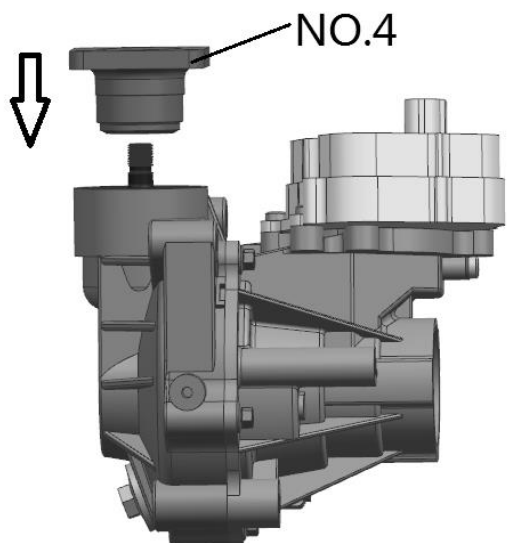

Fig 14

15. Mount the O-ring(NO.3).
→Fig 15

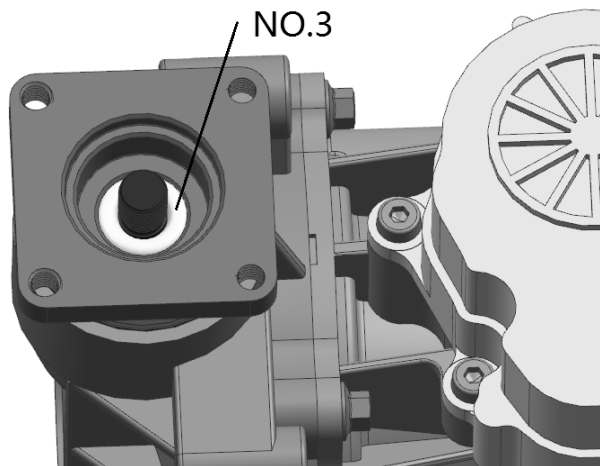

Fig 15

16. Apply some Loctite 263 thread locker on screw thread, mount the nut(NO.3), tighten it to a torque of 50~60Nm.
→Fig 16.

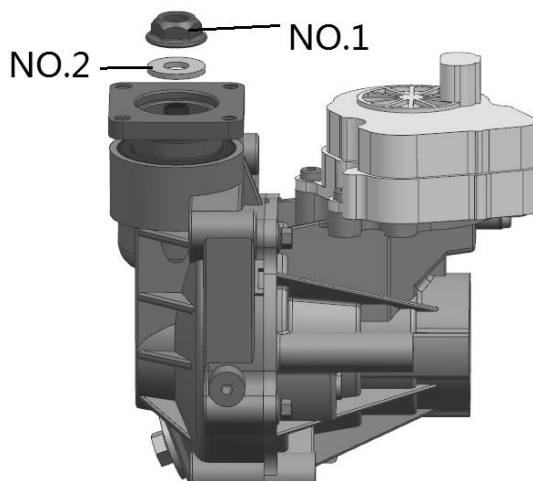

Fig 16

17. Add 200-250mL oil(85W/90GL-4).

CHAPTER 6 BRAKES

WARNING

The parts of different types/ variants/ versions maybe un-interchangeable, even some parts have almost same appearance. Always refer to Parts Manual of each UTV model for spare parts information and service.

NOTE: Also See Chapter 2 for Maintenance Information.

6.1 SPECIFICATIONS

6.2 TORQUE

6.3 BRAKE SYSTEM SERVICE NOTES

6.4 BURNISHING PROCEDURE

6.5 BRAKE BLEEDING-FLUID CHANGE

6.6 PARKING BRAKE AND BRAKE LINE INSPECTION

6.7 PARKING BRAKE ADJUSTMENT

6.8 PARKING BRAKE CALIPER REMOVAL/INSTALL

6.9 FRONT PAD INSPECTION / REMOVAL / REPLACEMENT

6.10 FRONT DISC INSPECTION / REMOVAL / REPLACEMENT

6.11 FRONT CALIPER REMOVAL/ INSPECTION / INSTALLATION

6.12 REAR BRAKE PAD REMOVAL/ INSPECTION / INSTALLATION

6.13 REAR CALIPER REMOVAL/ INSPECTION/ INSTALLATION

6.14 REAR BRAKE DISC INSPECTION / REMOVAL / REPLACEMENT

6.1 SPECIFICATIONS

Front Brake Caliper		
Item	Standard	Service Limit
Brake Pad Friction material Thickness	0.157"/ 5.5mm	0.04"/ 1mm
Brake Disc Thickness	0.150- 0.164"/3.810- 4.166mm	0.140"/ 3.556mm
Brake Disc Thickness Variance Between Measurements	-	0.002 " / .051m m
Brake Disc Runout	-	0.005 " / .127mm
Rear Brake Caliper		
Item	Standard	Service Limit
Brake Pad Friction material Thickness	hydraulic	0.157"/ 5.5mm
	Hydraulic with mechanics park	-
	mechanics park	0.354"/ 9mm
Brake Disc Thickness	0.150- 0.164"/3.810- 4.166mm	0.140"/ 3.556mm
Brake Disc Thickness Variance Between Measurements	-	0.002 " / 0.051mm
Brake Disc Run out	-	0.005 " / 0.127mm

6.2 TORQUE

Item	Torque (ft. lbs. except where noted*)	Torque (Nm)
Front Caliper Mounting Bolts	18.0	25
Rear Caliper Mounting Bolts	18.0	25
Front Brake Disc	18.0	25
Rear Brake Disc	18.0	25
Park Brake Mouting Bolts	33	45
Banjo Bolt	15.0	21

6.3 BRAKE SYSTEM SERVICE NOTES

- It is strongly recommended always change the caliper and (or) the master cylinder as an assembly. The parts inside maybe not interchangeable due to different brake manufactures and (or) different brake type.
- Do not over – fill the master cylinder fluid reservoir.

- Make sure the brake lever or pedal returns freely and completely.
- Check and adjust master cylinder reservoir fluid level after pad service.
- Make sure atmospheric vent on reservoir is unobstructed.
- Adjust foot brake after pad service.
- Test for brake drag after any brake system service and investigate cause if brake drag is evident.
- Make sure caliper moves freely on guide pins (where applicable) .
- Inspect caliper piston seals for foreign material that could prevent caliper pistons from returning freely.
- Perform a brake burnishing procedure after install new pads to maximize service life.
- DO NOT lubricate or clean the brake components with aerosol or petroleum products. Use only approved brake cleaning products.

6.4 BURNISHING PROCEDURE

Brake pads (both hydraulic and mechanical) must be burnished to achieve full braking effectiveness. Braking distance will be extended until brake pads are properly burnished. To properly burnish the brake pads, use the following procedure.

1. Choose an area large enough to safely accelerate the UTV to 50 km/h (30 mph) and to brake to a stop.
2. Using higher gear, accelerate to 50 km/h (30 mph); then compress brake lever (pedal) to decelerate to 0-8km/h (5 mph).
3. Repeat procedure on each brake system 20 times until brake pads are burnished.
4. Adjust the mechanical parking brake (if necessary).)
5. Verify that the brake light illuminates when the hand lever is compressed or the brake pedal is depressed.

WARNING

Failure to properly burnish the brake pads could lead to premature brake pad wear or brake loss. Brake loss can result in severe injury or death.

6.5 BRAKE BLEEDING-FLUID CHANGE

NOTE: When bleeding the brakes or replacing the fluid always start with the caliper farthest from the master cylinder.

CAUTION:

Always wear safety glasses.

CAUTION:

Brake fluid is highly corrosive. Do not spill brake fluid on any surface of the UTV.

This procedure should be used to change fluid or bleed brakes during regular maintenance.

1. Clean reservoir cover thoroughly.

2. Remove cap from reservoir.



3. If changing fluid, remove old fluid from reservoir with a brake fluid pump or similar tool.

4. Add brake fluid up to the indicated MAX level on the reservoir.

DOT 3 Brake Fluid

5. Begin bleeding procedure with the caliper that is farthest from the master cylinder. Install a box end wrench on the caliper bleeder screw. Attach a clean, clear hose to the fitting and place the other end in a clean container. Be sure the hose fits tightly on the fitting.

6. Slowly pump foot pedal until pressure builds and holds.

7. Hold brake pedal on to maintain pedal pressure, and open bleeder screw. Close bleeder screw and release foot pedal.

NOTE: Do not release foot pedal before bleeder screw is tight or air may be drawn into master cylinder.

8. Repeat procedure until clean fluid appears in bleeder hose and all air has been purged. Add fluid as necessary to maintain level in reservoir.

CAUTION:

Maintain at least 1/2 "(13mm) of brake fluid in the reservoir to prevent air from entering the master cylinder.

9. Tighten bleeder screw securely and remove bleeder hose.

10. Repeat procedure steps 5- 9 for the remaining calipers.
11. Add brake fluid up to the indicated MAX level on the reservoir.

**Master Cylinder Fluid Level
Between the MIN line and the MAX line of reservoir.**

12. Install master cylinder reservoir cap.
13. Field test machine at low speed before putting into service. Check for proper braking action and pedal reserve. With pedal firmly applied, pedal reserve should be no less than 1/2 " (13mm).
14. Check brake system for fluid leaks and inspect all hoses and lines for wear or abrasion. Replace hose if wear or abrasion was found.



6.6 PARKING BRAKE AND BRAKE LINE INSPECTION

1. Inspect the spring on the parking brake lever assembly.

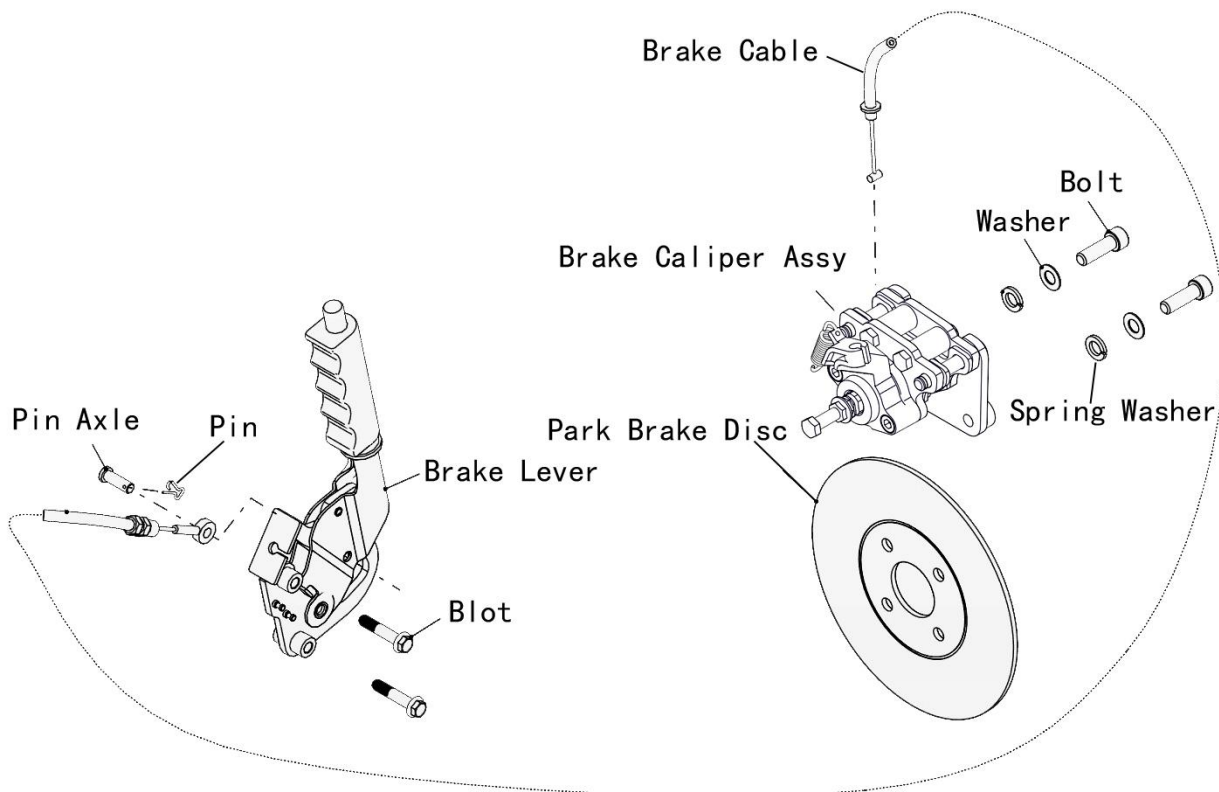

2. Inspect the parking brake cable at the parking brake lever assembly on the parking brake caliper.

3. Inspect the brake lines and brake line connections for possible leaks or loose lines.

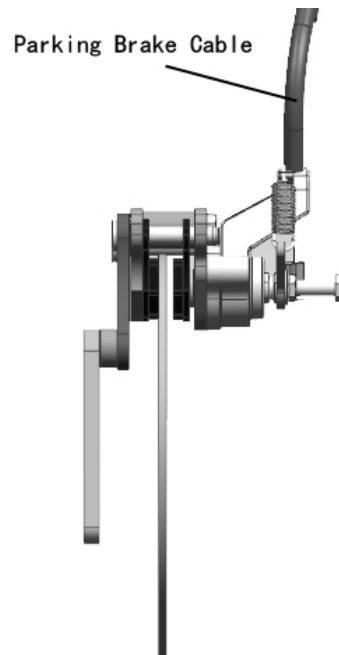

6.7 PARKING BRAKE ADJUSTMENT

Parking Brake Inspection

1. Pull the parking brake lever up with your hand.
2. After 2 to 4 clicks of lever travel, the vehicle should not roll while parked.
3. If the vehicle moves, adjustment is necessary.
4. Adjust the parking brake where the cable attaches to the lever assembly on the rear brake caliper.

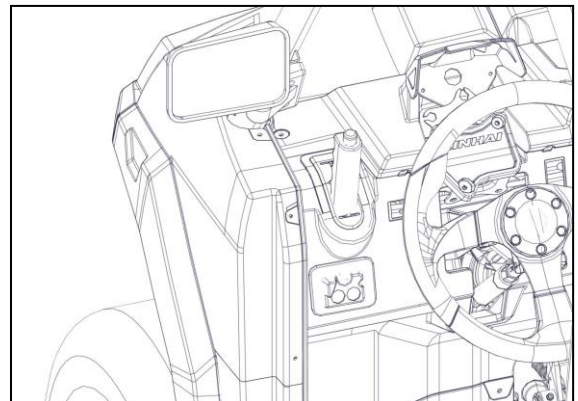

Parking Brake Adjustment

1. Place the vehicle in neutral on a flat level surface.
2. Carefully lift the rear of the vehicle off the ground and stabilize on jack stands.
3. Loosen the jam nut (A) on the rear caliper adjustment bolt (B).
4. Tighten the adjustment bolt (B) until the rear tire will not rotate.
5. Rotate the adjustment bolt (B) counterclockwise by 1/4 turn.
6. Tighten the jam nut (A) while holding the adjustment bolt (B) in place.

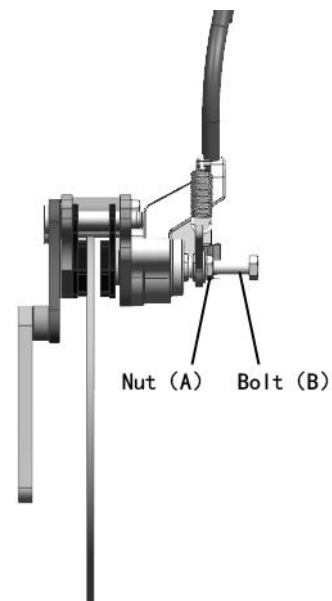

6.8 PARKING BRAKE CALIPER REMOVAL / INSTALL

Parking Brake Caliper Removal / Pad Inspection

NOTE: Do not get oil, grease or fluid on the parking brake pads. Damage to the pads may cause the pads to function improperly.

1. Loosen the two brake caliper bolts in equal increments. Remove the bolts from the bracket and lift parking brake caliper out.

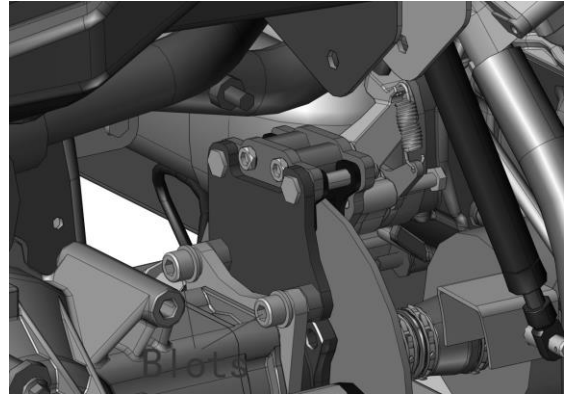

蹄片图纸的单词拼写错误: minimum (下文同样换图)

2. Measure the thickness of pads of the parking brake caliper. Replace pads if worn beyond the service limit.
Service Limit 0.3/64"(1 mm)

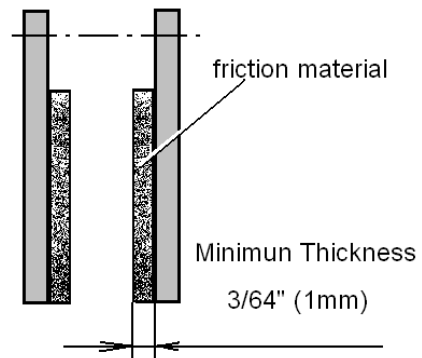

Parking Brake Caliper Installation

1. Install the parking brake caliper into place.
Tighten the two bolts in increments for proper installation.
2. Torque the two bolts to 33ft.lbs. (45 Nm).
3. Test the parking brake for proper function.

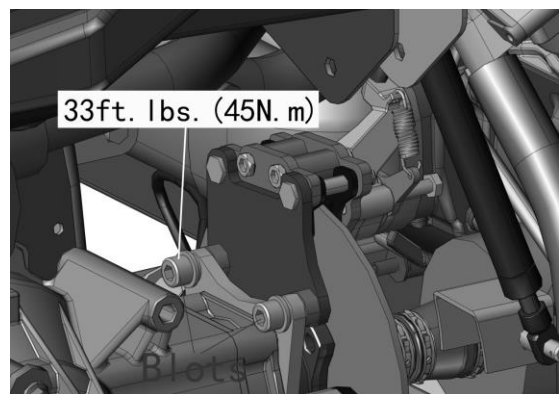

6.9 FRONT PAD REMOVAL / INSPECTION / INSTALLATION

NOTE: The brake pads should be replaced as a set.

REMOVAL

1. Elevate and support front of UTV safely.

CAUTION:

Be careful when supporting vehicle so that it does not tip or fall. Severe injury or death may occur if machine tips or falls.

2. Remove the front wheel.

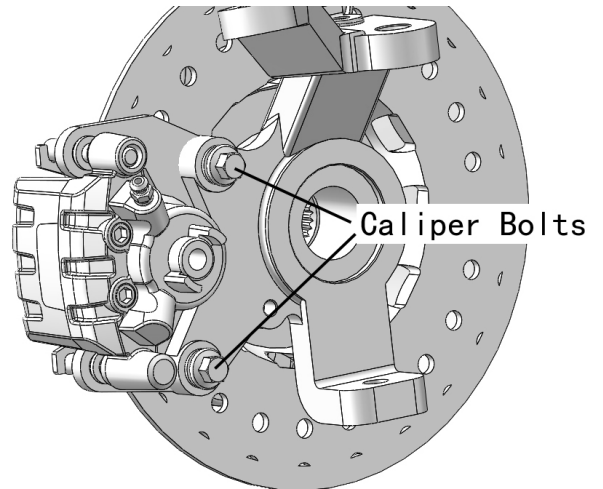

3. Remove the two caliper bolts and caliper from mounting bracket.

4. Push caliper piston into caliper bore slowly using a C-clamp or locking pliers with pads installed.

NOTE: Brake fluid will be forced through compensating port into master cylinder fluid reservoir when piston is pushed back into caliper. Remove excess fluid from reservoir as required.

5. Push mounting bracket inward and slip outer brake pad past edge. Remove inner pad.



INSPECTION

Measure the thickness of the pad friction material. Replace pads if worn beyond the service limit.

Service Limit 0.3/64" (1 mm)

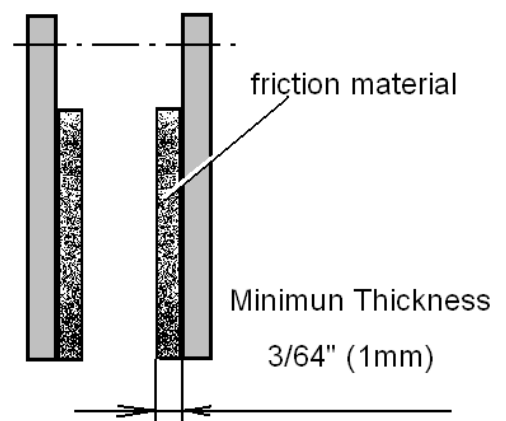

INSTALLATION

1. Lubricate mounting bracket pins with a light film of All Season Grease, and install rubber dust boots.
2. Compress mounting bracket and make sure dust boots are fully seated. Install pads with friction material facing each other. Be sure pads and disc are free of dirt or grease.
3. Install caliper on hub strut with torque mounting bolts.

Front Caliper Mounting Bolts**Torque 18 ft. lbs. (25 Nm)**

4. Slowly pump the brake lever until pressure has been built up. Maintain at least 1/2 "(13 mm) of brake fluid in the reservoir to prevent air from entering the brake system.
5. Install the adjuster screw and turn clockwise until stationary pad contacts disc, then back off 1/2 turn (counter clockwise).
6. Be sure fluid level in reservoir is up to the MAX line on the reservoir and install reservoir cap.

Master Cylinder Fluid**Up to the MAX line on the reservoir**

7. Install wheels and torque wheel nuts.
8. It is recommended that a burnishing procedure be performed after installation of new brake pads to extend service life and reduce noise. Start machine and slowly increase speed to 30 mph. Gradually apply brakes to stop machine. Repeat procedure 10 times.

**6.10 FRONT DISC INSPECTION / REMOVAL / REPLACEMENT****INSPECTION**

1. Visually inspect the brake disc for nicks, scratches, or damage.
2. Measure the disc thickness at 8 different points around the pad contact surface using a 0-1" micrometer and a dial indicator. Replace disc if worn beyond service limit.

Brake Disc Thickness

New 0.150-0.164" (3.810 - 4.166 mm)

Service Limit 0.140" (3.556 mm)

Brake Disc Thickness Variance

Service Limit 0.002 " (0.051 mm)

difference between measurements

3. Mount dial indicator as shown to measure disc runout on the dial indicator. Replace the disc if runout exceeds specifications.

Brake Disc Runout

Service Limit 0.005" (0.127 mm)



REMOVAL/ REPLACEMENT

1. Removal caliper and hub. Apply heat to the hub in the area of the brake disc mounting bolts to soften the bolt locking agent.
2. Remove bolts and disc.
3. Clean mating surface of disc and hub.
4. Install new disc on hub and tighten to specified.

CAUTION:

Always use new brake disc mounting bolts.

Front Brake Disc Mounting Bolt Torque :
18 ft. lbs. (25 Nm)

6.11 FRONT CALIPER REMOVAL/ INSPECTION / INSTALLATION

CAUTION:

The caliper is a non-serviceable component; it must be replaced as an assembly.

NOTE: If any special service needed, contact the UTV manufacturer via the agent for the parts and special instruction.

REMOVAL

1. Remove wheel, remove caliper from the strut.
2. Loosen and remove brake hose to caliper. Place a container under caliper to catch fluid draining.

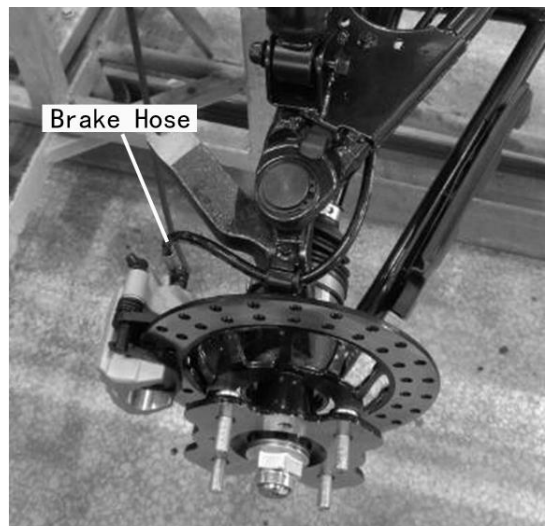

INSPECTION

Inspect caliper body for nicks, scratches or worn. Replace caliper as an assembly if any problem exists.

INSTALLATION

1. Install caliper on hub strut, Apply Loctite™ 243 to screw threads and Install new bolts.

Front Caliper Mounting Bolt Torque**18 ft. lbs. (25 Nm)**

2. Install brake hose and tighten to specified torque.

Banjo Bolt Torque: 15 ft. lbs. (21 Nm)

NOTE: If new brake pads are installed, it is recommended that a burnishing procedure be performed after installation of new brake pads to extend service life and reduce noise. Start machine and slowly increase speed to 30 mph. Gradually apply brakes to stop machine. Repeat procedure 10 times.

6.12 REAR BRAKE PAD REMOVAL/ INSPECTION / INSTALLATION

NOTE: The brake pads should be replaced as a set.

REMOVAL

1. Elevate and support rear of UTV safely.

CAUTION:

Be careful when supporting vehicle so that it does not tip or fall. Severe injury or death may occur if machine tips or falls.

2. Remove the rear wheel.
3. Remove the two caliper bolts and lift caliper off of disc.

NOTE: When removing caliper, be careful not to damage brake line. Support caliper so as not to kink or bend brake line.

4. Push caliper piston into caliper bore slowly using a C-clamp or locking pliers with pads installed.

NOTE: Brake fluid will be forced through compensating port into master cylinder fluid

Rear Caliper Mounting Bolts

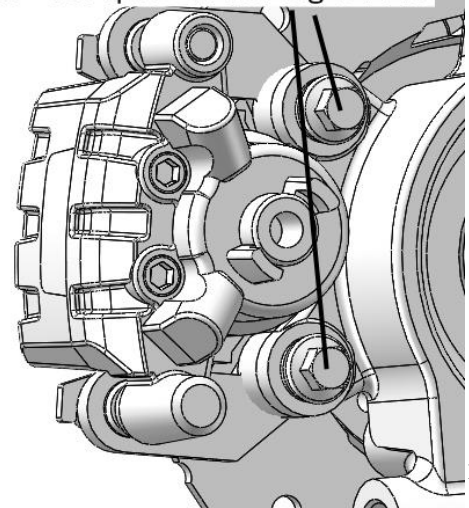

- reservoir when piston is pushed back into caliper.
 Remove excess fluid from reservoir as required.
5. Remove the brake pads.
 6. Clean the caliper with brake cleaner or alcohol.

INSPECTION

Measure the thickness of the pad friction material.
 Replace pads if worn beyond the service limit.

Service Limit 0.3/64"(1 mm)

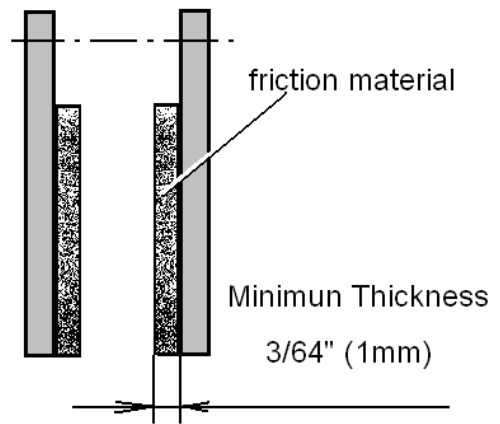

INSTALLATION

1. Install new pads in caliper body.
2. Install caliper and torque mounting bolts.
Brake Caliper Torque: 18 ft. lbs. (25 Nm)
3. Turn adjuster screw back in finger tight using a hex wrench.
4. Slowly pump the brake lever until pressure has been built up. Maintain at least 1/2 "(13 mm) of brake fluid in the reservoir to prevent air from entering the brake system.
5. Install wheels, burnishing procedure should be performed.

6.13 REAR CALIPER REMOVAL/ INSPECTION/ INSTALLATION

CAUTION:

The caliper is a non-serviceable Component; it must be replaced as an assembly.

NOTE: If any special service needed, contact the UTV manufacturer via the agent for the parts and special instruction.

CAUTION:

Be careful when supporting vehicle so that it does not tip or fall. Severe injury or death may occur if machine tips or falls.

1. Safely support the rear of the machine.
2. Use a wrench to remove the brake hose. Place a



container to catch brake fluid draining from brake lines.

3. After the fluid has drained into the container, remove the caliper mounting bolts and remove caliper.
4. Remove brake pad as described above.
5. Inspect surface of caliper for nicks, scratches or damage and replace if necessary.
6. Install brake pads in caliper body with friction material facing each other, with the spacer between the pads. Install retaining pin through outer pad, pad spacer and inner pad.
7. Install caliper and torque mounting bolts to 18 ft.lbs. (25 Nm).
8. Install brake hose and tighten to specified torque.

Banjo Bolt Torque: 15 ft. lbs. (21 Nm)

9. Bleed.
10. Field test unit for proper braking action before putting into service. Inspect for fluid leaks and firm brakes. Make sure the brake is not dragging when lever is released. If the brake drags, recheck assembly and installation.
11. Install the rear wheel and wheel nuts. Carefully lower the vehicle.

NOTE: If new brake pads are installed, it is recommended that a burnishing procedure be performed after installation of new brake pads to extend service life and reduce noise.

6.14 REAR BRAKE DISC INSPECTION / REMOVAL / REPLACEMENT

INSPECTION

1. Visually inspect the brake disc for nicks, scratches, or damage.
2. Measure the disc thickness at 8 different points around the pad contact surface using a 0-1" micrometer and a dial indicator. Replace disc if worn beyond service limit.

Brake Disc Thickness

New 0.150-0.164" (3.810 - 4.166 mm)

Service Limit 0.140" (3.556 mm)

Brake Disc Thickness Variance

**Service Limit 0.002 " (0.051 mm)
difference between measurements**

3. Mount dial indicator as shown to measure disc runout on the dial indicator. Replace the disc if runout exceeds specifications.

**Brake Disc Runout
Service Limit 0.005" (0.127 mm)**

REMOVAL/ REPLACEMENT

1. Remove wheel/ hub and caliper.
2. Remove bolts and disc from the hub.
3. Clean mating surface of disc and hub.
4. Install new disc on the hub.

Tighten to specified.

**Rear Brake Disc Mounting Bolt Torque :
18 ft. lbs. (25 Nm)**

CAUTION:

Always use new brake disc mounting bolts.

CHAPTER 7 ELECTRICAL

- 7.1 PARTS INSPECTION AND SERVICE
- 7.2 BATTERY
- 7.3 IGNITION SYSTEM
- 7.4 CHARGING SYSTEM
- 7.5 ELECTRICS STARTING SYSTEM
- 7.6 COOLING SYSTEM
- 7.7 LIGHTING SYSTEM
- 7.8 GEAR SHIFT SWITCH TEST
- 7.9 SPEEDOMETER SYSTEM
- 7.10 SWITCHES
- 7.11 FUEL GAUGE/ FUEL LEVEL SENSOR
- 7.12 THE OPERATION PRINCIPLE OF THE ELECTRIC 4WD SHIFT
- 7.13 WIRING DIAGRAM

7.1 PARTS INSPECTION AND SERVICE

HEADLIGHT LAMP REPLACEMENT

The headlight assy are LED lights , which cannot be repaired if damaged or failed ,Please have your dealer replace the entire assembly when the LED light is damaged or failed.

Headlight Lamp Adjustment

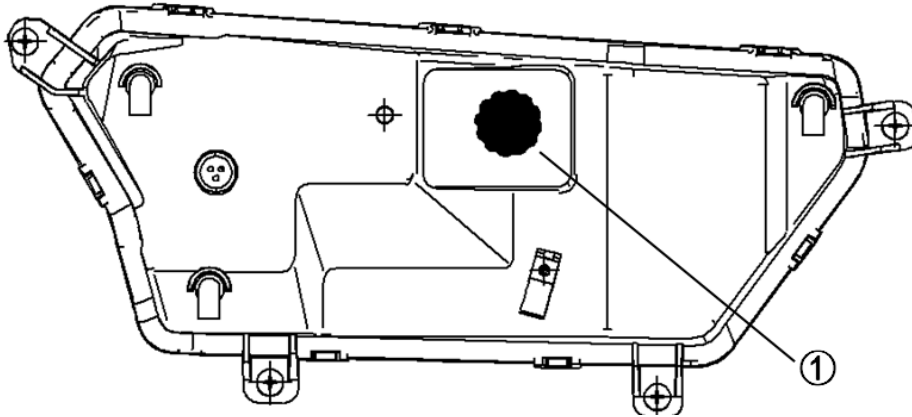

1. To lower headlight brightness cut-off line, turn adjusting bolt① counterclockwise. And to raise brightness cut-off line, turn the bolt clockwise.
2. This type of headlight is LED , do not try to replace the bulb, if there is a problem with the headlight, please contact the dealer.

Taillight / Brake light Lamp Replacement

The tail light assy are LED lights , which cannot be repaired if damaged or failed ,Please have your dealer replace the entire assembly when the LED light is damaged or failed.

7.2 BATTERY

Battery electrolyte is poisonous. It contains sulfuric acid. Serious burns can result from contact with skin, eyes or clothing Antidote:

External: Flush with water.

Internal: Drink large quantities of water or milk. Follow with milk of magnesia, beaten egg, or vegetable oil. Call physician immediately.

Eyes: Flush with water for 15 minutes and get prompt medical attention.

Batteries produce explosive gases. Keep sparks, flame, cigarettes, etc. away. Ventilate when charging or using in an enclosed space. Always shield eyes when working near batteries.

KEEP OUT OF REACH OF CHILDREN

WARNING: The gases given off by a battery are explosive. Any spark or open flame near a battery can cause an explosion which will spray battery acid on anyone close to it. If battery acid gets on anyone, wash the affected area with large quantities of cool water and seek immediate medical attention.

Battery Maintenance

1. If the vehicle will not be used for more than one month, remove the battery, fully charge it, and then place it in a cool, dry place. If the battery will be stored for more than two months, check it at least once a month and fully charge it if necessary.

CAUTION

To charge this battery, a specified battery charger is required. Using a conventional battery charger will damage the battery.

2. Ensure to the cables are properly routed when installing the battery.

BATTERY TESTING

Whenever a service complaint is related to either the starting or charging systems, the battery should be checked first.

Following are three tests which can easily be made on a battery to determine its condition: OCV Test, Specific Gravity Test and Load Test.

MF (Maintenance Free) battery does not require the Specific Gravity Test and Refill**Open Circuit Voltage Test**

Battery voltage should be checked with a digital multimeter. Readings of 12.6 or less require further battery testing and charging.

NOTE: Lead acid batteries should be kept at or near a full charge as possible.

Load test

CAUTION: Remove spark plug high tension leads and connect securely to engine ground before proceeding.

NOTE: This test can only be performed on machines with electric starters. This test cannot be performed with an engine or starting system that is not working properly.

A battery may indicate a full charge condition in the OCV test and the specific gravity test, but still may not have the storage capacity necessary to properly function in the electrical system. For this reason, a battery capacity or load test should be conducted whenever poor battery performance is encountered. To perform this test, hook a multimeter to the battery in the same manner as was done in the OCV test. The reading should be 12.6 volts or greater. Engage the electric starter and view the registered battery voltage while cranking the engine. Continue the test for 15 seconds. During this cranking period, the observed voltage should not drop below 9.5 volts. If the beginning voltage is 12.6 or higher and the cranking voltage drops below 9.5 volts during the test, replace the battery.

7.3 IGNITION SYSTEM**IGNITION SYSTEM TROUBLESHOOTING****No Spark, Weak or Intermittent Spark**

- Spark plug gap incorrect
- Fouled spark plug
- Faulty spark plug cap or poor connection to high tension lead
- Related wiring loose, disconnected, shorted, or corroded
- Engine stop switch or ignition switch faulty
- Terminal board or connections wet, corroded
- Poor ignition coil ground (e.g. coil mount loose or corroded)
- Faulty stator (measure resistance of all ignition related windings)
- Incorrect wiring (inspect color coding in connectors etc.)
- Faulty ignition coil winding (measure resistance of primary and secondary)
- Worn magneto (RH) end crankshaft bearings
- Sheared flywheel key
- Flywheel loose or damaged
- Trigger coil air gap too wide (where applicable) should be 0.030-0 .050" (0. 75-1.25 mm)
- Excessive crankshaft run out on magneto (RH) end should not exceed 0.005" (0.13mm)

DIAGRAM REFER TO "7.13 WIRING DIAGRAM"

IF THE IGNITION SYSTEM FAILS TO OPERATE

Procedure

Check:

- | | |
|--|---|
| <ol style="list-style-type: none"> 1. Fuse (Main) 2. Battery 3. Spark plug 4. Ignition spark gap | <ol style="list-style-type: none"> 5. Ignition coil 6. Pickup coil resistance 7. Main switch 8. Wiring connection |
|--|---|

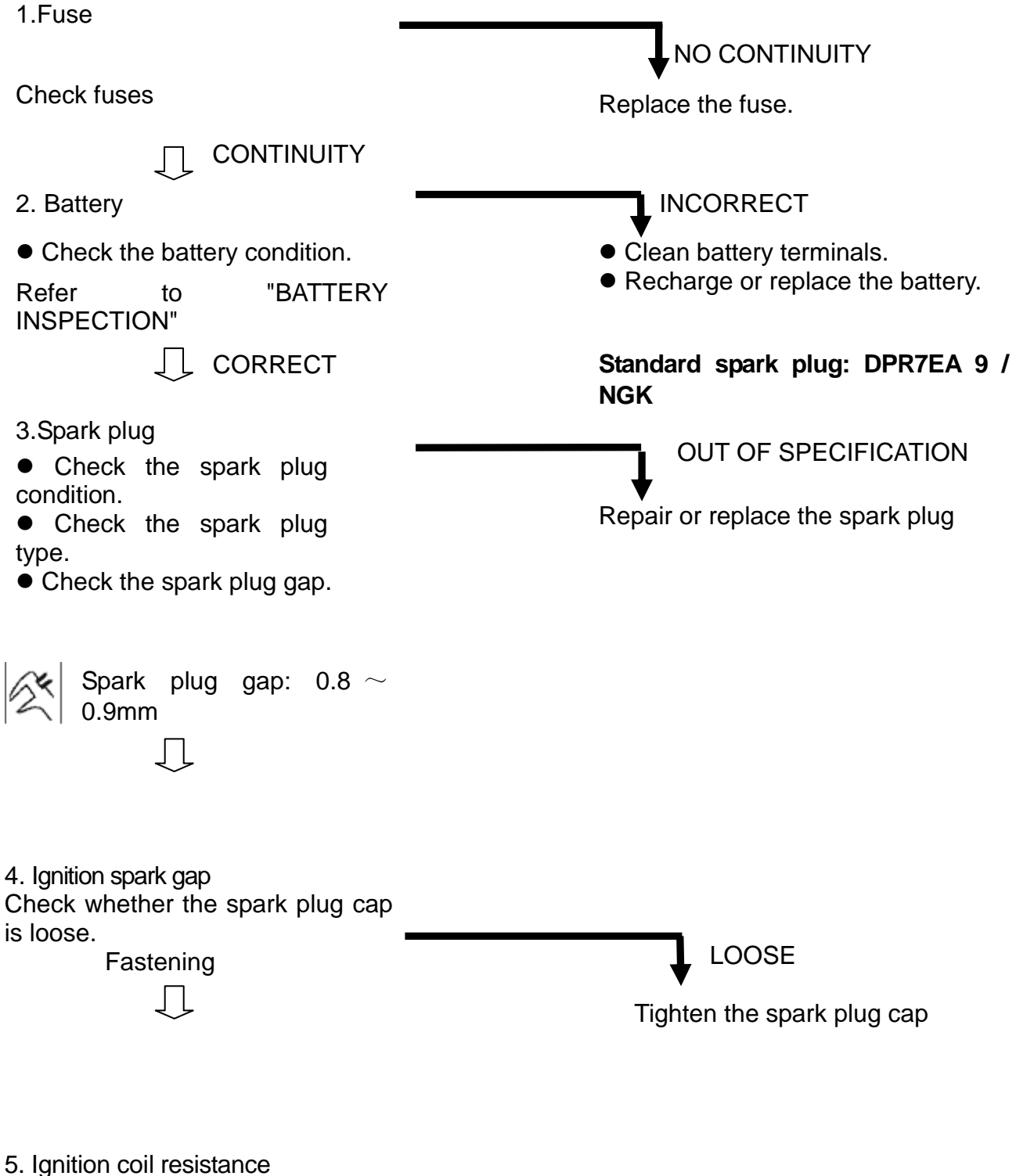

Disconnect the ignition coil connector from the wire harness.

- Connect the pocket tester ($\Omega \times 1$) to the ignition coil.
- Check if the primary coil has the specified resistance.

Tester (+) lead ① Terminal
Tester (-) lead ② Terminal

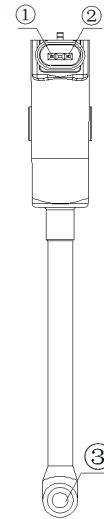

 **Primary coil resistance:**
 $0.58 \pm 0.058 \Omega$ (23°C)

OUT OF SPECIFICATION
 Replace the Ignition coil

↓ CORRECT

- Connect the pocket tester ($\Omega \times 20k$) to the ignition coil.
- Check the secondary has the specified resistance

Tester (+) lead ① Terminal
Tester (-) lead ③ Terminal

 **Secondary coil resistance:**
 $11.8 \pm 1k \Omega$ (23 °C)

OUT OF SPECIFICATION

↓ BOTH MEET SPECIFICATION

*

6. Pickup coil resistance

- Disconnect the pickup coil coupler from the wire harness.
- Connect the pocket tester ($\Omega \times 1K$) to the pickup coil coupler.

Tester (+) lead →

B/Y Terminal ①

Tester (-) lead →

B/R Terminal ②

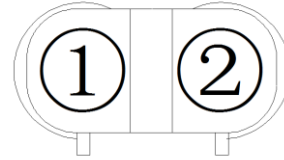

- Check the pickup coil has the specified resistance.



Primary coil resistance:
115 -145 Ω (20°C)

↓ MEETS SPECIFICATION

OUT OF SPECIFICATION
↓
Replace the pickup coil.

7. Main switch
CHECK SWITCHES

↓ CONTINIUTY

NO CONTINUITY
↓
Replace the main switch

8. Wiring connection
- Check the connection of the entire ignition system
- Refer to "CIRCUIT DIAGRAM".

↓ CORRECT

NO CONTINUITY
↓
Correct

Replace the igniter unit(ECU).

7.4 CHARGING SYSTEM

CHARGING SYSTEM CIRCUIT DIAGRAM

DIAGRAM REFER TO "7.13 WIRING DIAGRAM"

CURRENT DRAW - KEY OFF

CAUTION: Do not connect or disconnect the battery cable or ammeter with the engine running. Damage will occur to light bulbs and speed limiter. Connect an ammeter in series with the negative battery cable. Check for current draw with the key off, if the draw is excessive, loads should be disconnected from the system one by one until the draw is eliminated. Check component wiring as well as the component for partial shorts to ground to eliminate the draw.

Current draw key off:
Maximum of 0.01DCA(10mA)

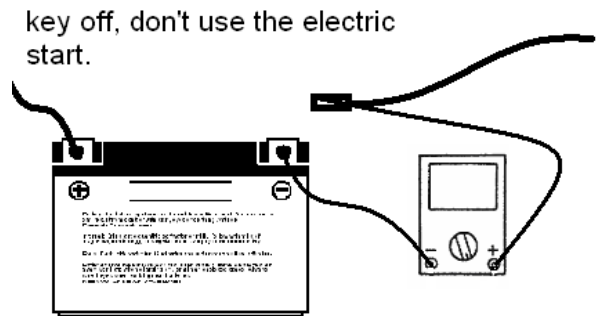

CHARGING SYSTEM

Procedure

Check:

- 1. Fuse (Main)
- 2. Battery
- 3. Charging voltage
- 4. Magneto coil resistance
- 5. Wiring system (entire charging system)

1. fuse

Check fuses



2. Battery

Check the battery condition.
Refer to "BATTERY INSPECTION"



3. Charging voltage

Connect the engine tachometer to the spark plug lead.

●Connect the pocket tester (DC20V) to the battery

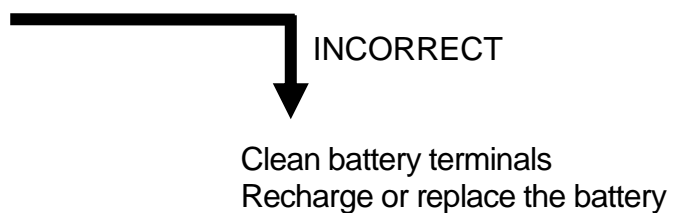
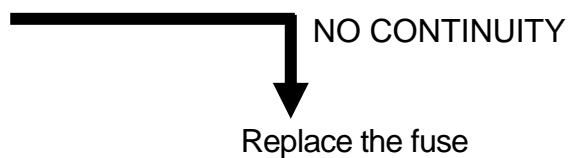

- Test (+) lead →
- Battery (+) terminal ①
- Tester (-) lead →
- Battery (-) terminal ②

Measure the battery terminal voltage.

start the engine and accelerate to about 5,000rpm

●check the terminal voltage

Measured voltage-terminal

Voltage:

0.2-2.5V up

NOTE: Use a fully charged battery.

↓ OUT OF SPECIFICATION

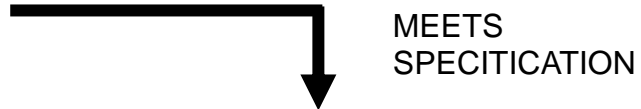

MEETS SPECIFICATION

The charging circuit is not faulty
Replace the battery

- 4. Magneto coil resistance
- Remove the A.C. magneto coupler from wire harness
- Connect the pocket tester ($\Omega X1$) to the stator coil
- Tester (+) lead –yellow terminal
- Tester (-) lead –yellow terminal
- Measure the stator coil resistance
- Stator coil resistance 0.5-0.8 Ω (20 $^{\circ}$ C)

↓ MEETS SPECIFICATION

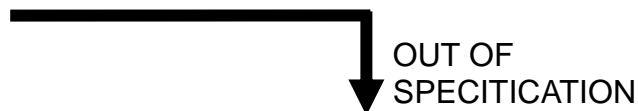

OUT OF SPECIFICATION

Replace the Magneto coil

- 5. Wiring connection
- check the entire charging system for connections
- Refer to "CIRCUIT DIAGRAM"

↓ CORRECT

Replace the rectifier/regulator

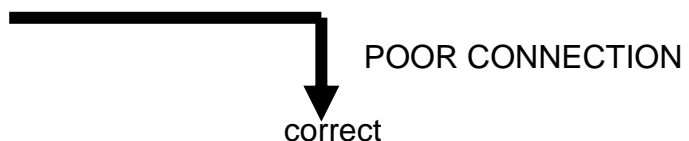

POOR CONNECTION

correct

7.5 ELECTRICS STARTING SYSTEM

DIAGRAM REFER TO "7.13 WIRING DIAGRAM"

TROUBLESHOOTING

THE STARTER MOTOR OPERATES WHEN THE BRAKE SWITCH IS ON

IF THE STARTER MOTOR FAILS TO OPERATE

Procedure

Check:

- 1. Fuse (Main)
- 2. Battery
- 3. starter motor
- 4. starter relay

- 5. main switch
- 6. brake switch
- 7. Gear position sensor
- 8. starter switch
- 9. wiring connection (entire starting system)

1. fuse
Check fuses.

↓ CONTINUITY

NO CONTINUITY
↓
Replace the fuse

2. Battery
Check the battery condition.
Refer to "BATTERY INSPECTION"

↓ CORRECT

INCORRECT
↓
Clean battery terminals
Recharge or replace the battery

3. Starter motor
Connect the battery positive terminal and starter motor cable using a jumper lead.
Check the starter motor operation

DOES NOT MOVE
↓
Repair or replace the starter motor

4. Starter relay

- Disconnect the relay unit coupler from the wire harness.
- Connect the pocket tester ($\Omega \times 1$) and battery (12V) to the relay unit coupler terminals.

Battery (+) lead →
Green/Yellow terminal ①
Battery (-) lead →
Yellow/Red terminal ②

WARNING

A wire used as a jumper lead must have the equivalent capacity as that of the battery lead or more, otherwise it may burn.

This check is likely to produce sparks, so be sure that no flammable gas or fluid is in the vicinity

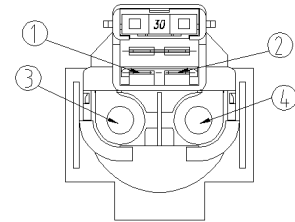

- Check the starter relay for continuity.

Test (+) lead → ③ terminal
Test (-) lead → ④ terminal

↓ CONTINUITY

↓ DOES NOT CONDUCTION
Replace the starter replay

5. Main switch
CHECK SWITCHES

↓ CONTINUITY

↓ NO CONTINUITY
Replace the main switch

6. Brake switch
CHECKING SWITCHES

↓ CONTINUITY

↓ NO CONTINUITY
Replace the brake switch

7. Gear position sensor

↓ CORRECT

Check if the meter shows N when the vehicle is in neutral
↓ INCORRECT
Replace the Gear position sensor

8. Starter switch

CHECKING SWITCHES

↓ CONTINUITY

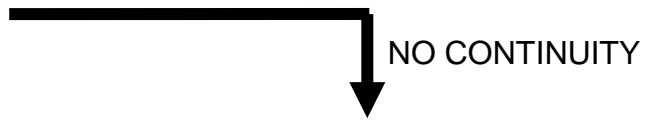

Replace the handlebar switch

9. Wiring connection

Check the connections of the entire starting system.

Refer to "CIRCUIT DIAGRAM

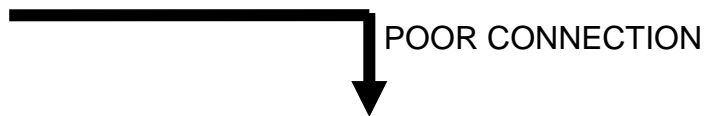

Correct

7.6 COOLING SYSTEM

DIAGRAM REFER TO "7.13 WIRING DIAGRAM"

When the main switch is turned on, the temperature of the engine begins to go up. As it comes to $93 \pm 1^\circ\text{C}$ the igniter assy (ECU) controls the fan starts to work, cooling the coolant, if the igniter assy (ECU), relay or the fan, fails to work; the coolant temperature will keep rising. The heat alarm unit operates the moment the temperature reaches $115 \pm 5^\circ\text{C}$ and the signal flashing. Stop the engine now to have the circuit fixed.

IF THE FAN MOTOR FAILS TO TURN

Procedure

Check:

- | | |
|---|---|
| <ul style="list-style-type: none"> 1. Fuse (Main, Fan) 2. Battery 3. Main switch | <ul style="list-style-type: none"> 4. Fan motor (inspection) 5. Relay 6. Wiring connection (entire cooling system) |
|---|---|

1. Fuse
Check fuses.



2. Battery
Check the battery condition.
Refer to "BATTERY INSPECTION" section



3. Main switch
CHECK SWITCHES



4. Fan motor
Connect the battery to the fan motor.

Battery (+) lead → Green/Blue terminal ①

Battery (-) lead → Green ground ②
Check the fan motor operation



DOES NOT MOVE

↓ MOVE

Replace fan motor

5. Relay

●Disconnect the starting circuit cut-off relay coupler from the wireharness.

●Connect the pocket tester ($\Omega \times 1$) and battery (12V) to the starting circuit cut-off relay coupler terminals.

Battery (+) lead → terminal ②

Battery (-) lead → terminal ④

●Check the starting circuit cut-off relay for continuity.

Test (+) lead → ① terminal

Test (-) lead → ③ terminal

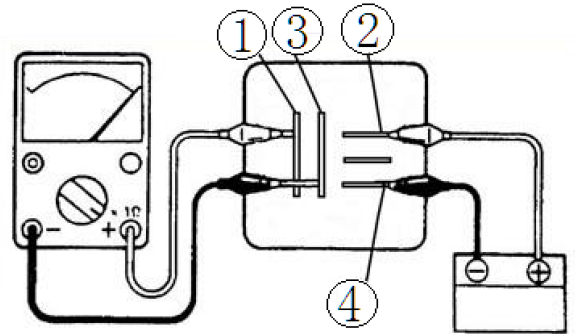

↓ DOES NOT CONDUCTION
Replace the fan replay

↓ CONDUCTION

6. Wring connection

●Check the connection of the entire cooling system.

Refer to "CIRCUIT DIAGRAM"

↓ UPPER CONNECTION
Correct

↓ CONTINUITY

Replace the igniter assy (ECU).

7.7 LIGHTING SYSTEM

DIAGRAM REFER TO "7.13 WIRING DIAGRAM"

TROUBLESHOOTING

Procedure

Check:

- 1. Fuse (Main)
- 2. Battery
- 3. Main switch

- 4. High/low beam switch and turn switch
- 5. Flasher relay and relay
- 6. Wiring connection (entire lighting system)

1. fuse

Check fuses.

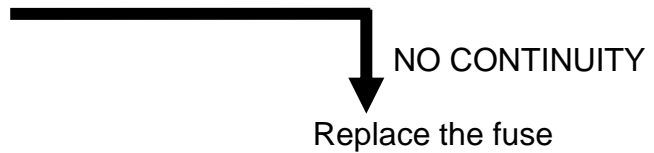

2. Battery

Check the battery condition.

Refer to "BATTERY INSPECTION" section

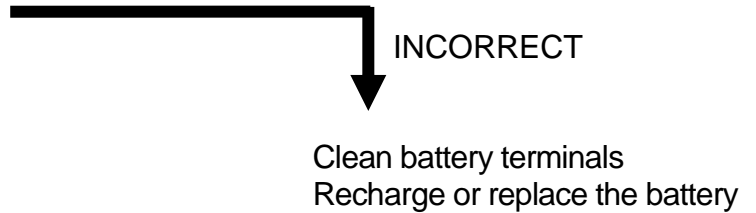

3. Main switch

CHECK SWITCHES

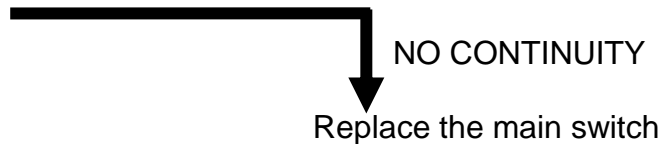

4. High/low beam switch and turn switch

CHECK SWITCHES

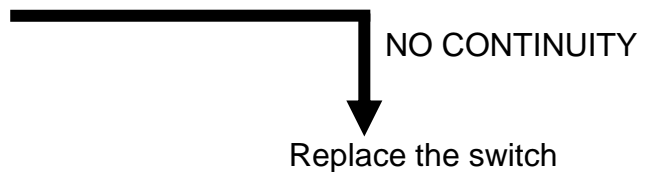

5. Flasher relay and relay

Check flasher relay and relay
 Check relay refer to "7.6 COOLING SYSTEM" "5. Relay"

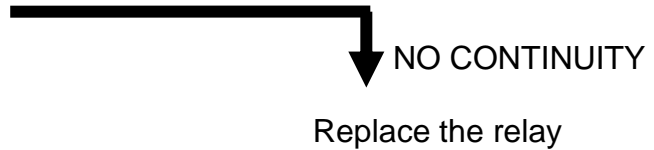

6. Wiring connection

6.1 Check the connection of the entire lighting system

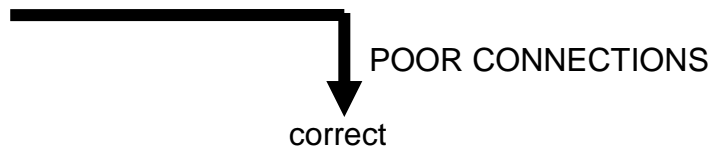

6.1 check the condition of each of the lighting system's circuits

Refer to "LIGHTING SYSTEM CHECK"

LIGHT SYSTEM CHECK

1. If the high/low beam light and direction indicator fail to come on

1. Light connector
 CHECK connector

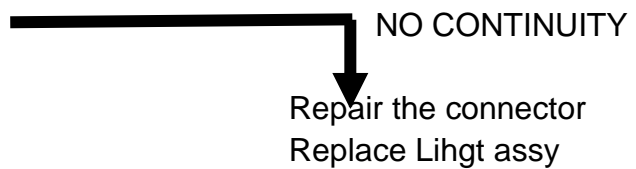

2. Voltage

Connect the pocket tester (DC20V) to the high/low beam light and direction indicator light couplers.

A When the High/low beam switch is on high beam

High beam light:

Tester (+) lead → Blue lead

Tester negative (-) lead → Green lead

B When the High/low beam switch on low beam

Low beam light:

Tester (+) lead → White lead

Tester negative (-) lead → Green lead

C When the High/low beam switch on position light

Front/rear position light:

Tester (+) lead →Black lead
 Tester negative (-) lead →Green lead
D When the turn switch on turn right position
 Front/rear turn right light(LED)
 Tester (+) lead →Light Blue lead
 Tester negative (-) lead →Green lead
E When the turn switch on turn left position

Front/rear turn left light(LED)
 Tester (+) lead →Orange lead
 Tester negative (-) lead →Green lead

Check for voltage (12V) on the lead at bulb socket connectors



This circuit is not faulty
 Replace the bulb.
 If the light is LED,replace the light directly

2. the taillight fails to come on

1. Voltage
 Connect the pocket tester (DC20V) to the taillight couplers
Tester (+) lead→
Green/Yellow terminal
Tester (-) lead→
Green terminal
 Turn the main switch to on.
 Step on brake.
 Check the voltage (12V) on the taillight couplers



This circuit is not faulty
 Replace the light assy.

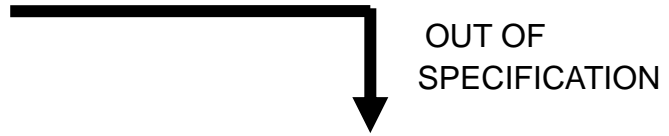

The wiring circuit from the main switch to bulb socket connector is faulty. Repair



The wiring circuit from main switch to light connector of faulty. Repair

7.8 GEAR SHIFT SWITCH TEST

DIAGRAM REFER TO "7.13 WIRING DIAGRAM"

Switch table

	Br/W	Gr/R	G/W	Pu	G
L	●				●
H		●			●
N			●		●
R				●	●

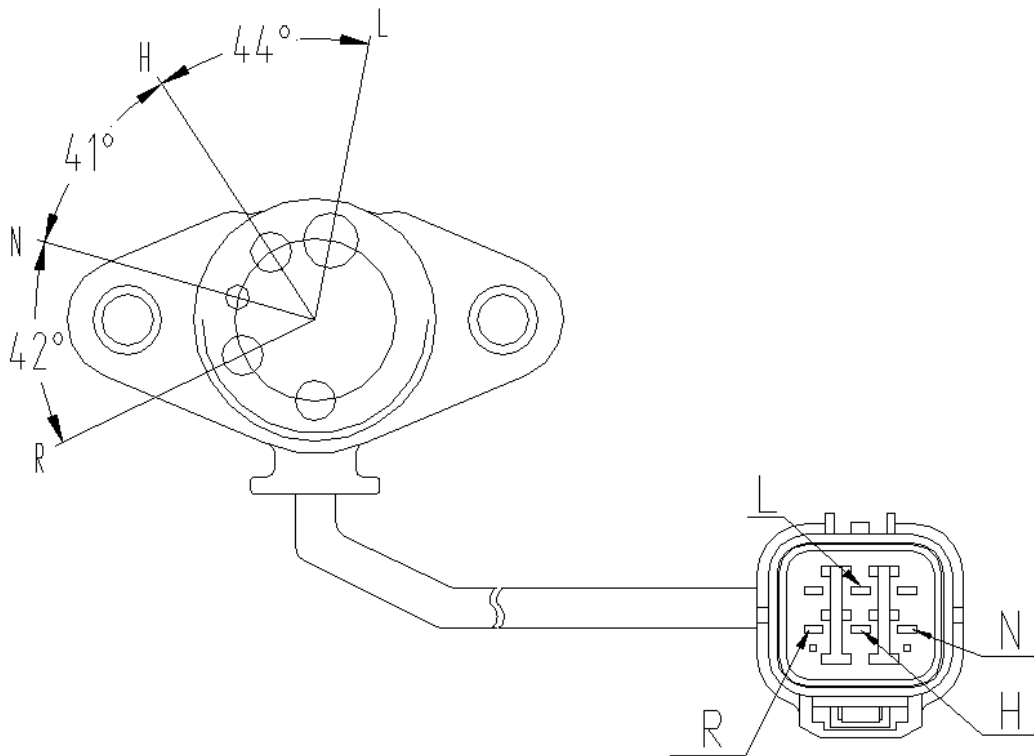

7.9 SPEEDMETER SYSTEM

OPERATION OF SPPEED SENSOR

Speed Sensor is on the gearbox

This sensor is used to detect the rotating speed of the engine output shaft and provide the signal for ECU and speedometer to determine the vehicle speed. It belongs to Hall effect sensor,that varies its output voltage in response to a magnetic field.

- 1. Ground
- 2. Output voltage signal
- 3. Power DC 12V(+)

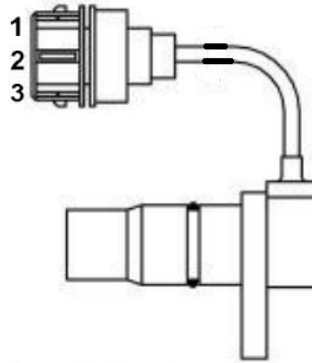

The following figure refers to speed sensor wiring

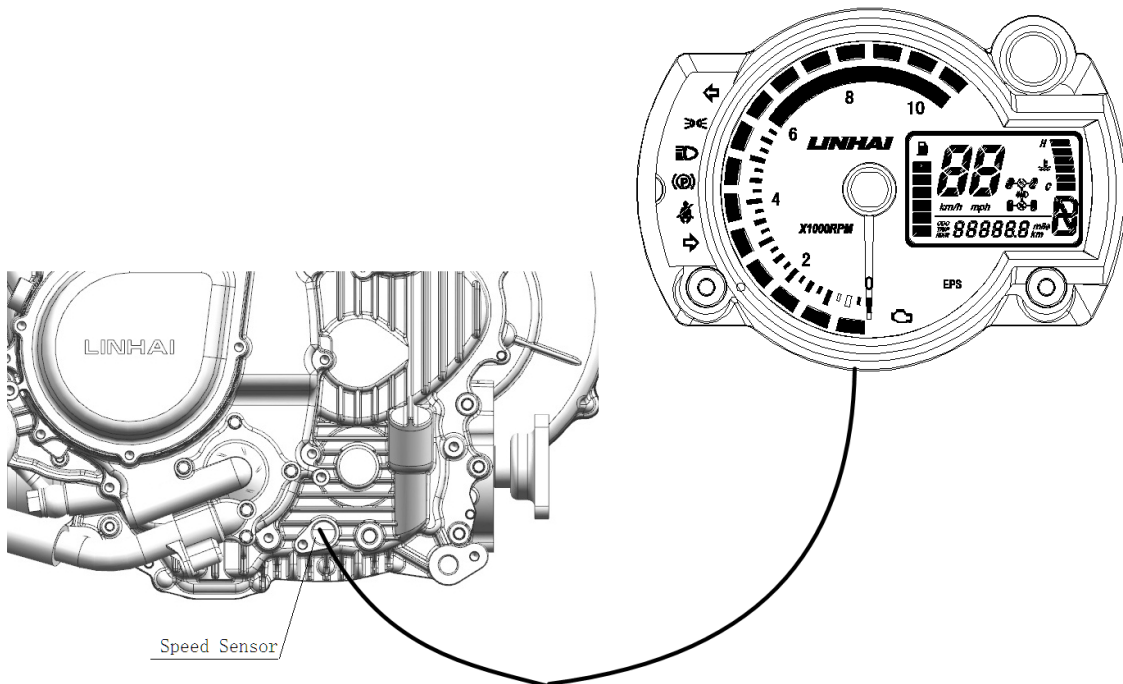
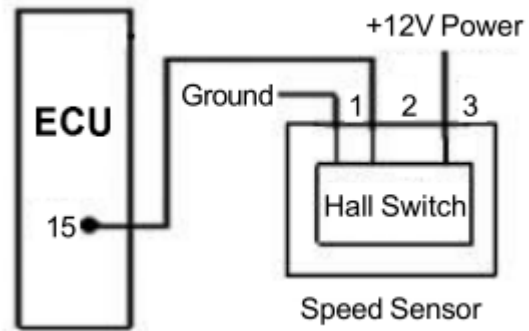

Speed Sensor Test:

- Ground pin 1 and connect pin 3 with +12V power;
- Fix a gear 2.5mm away from a speed sensor as the right figure illustrates;
- Turn multimeter to DCV range;
- Slowly turn the gear and measure the voltage between pin 2 and pin 3 to determine that if the reading varies from 0V-12V;
- If the reading doesn't vary, that indicates the sensor is defective and needs to be replaced

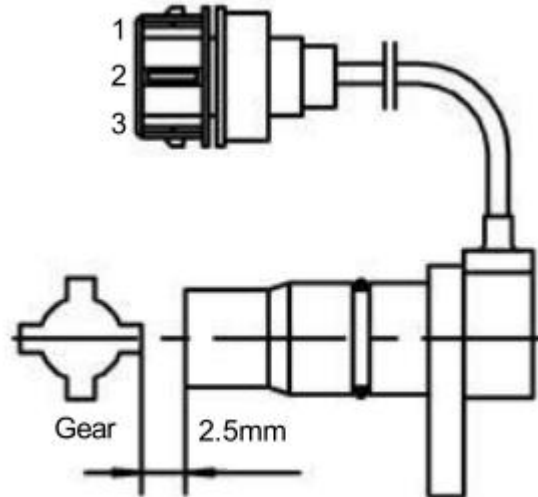

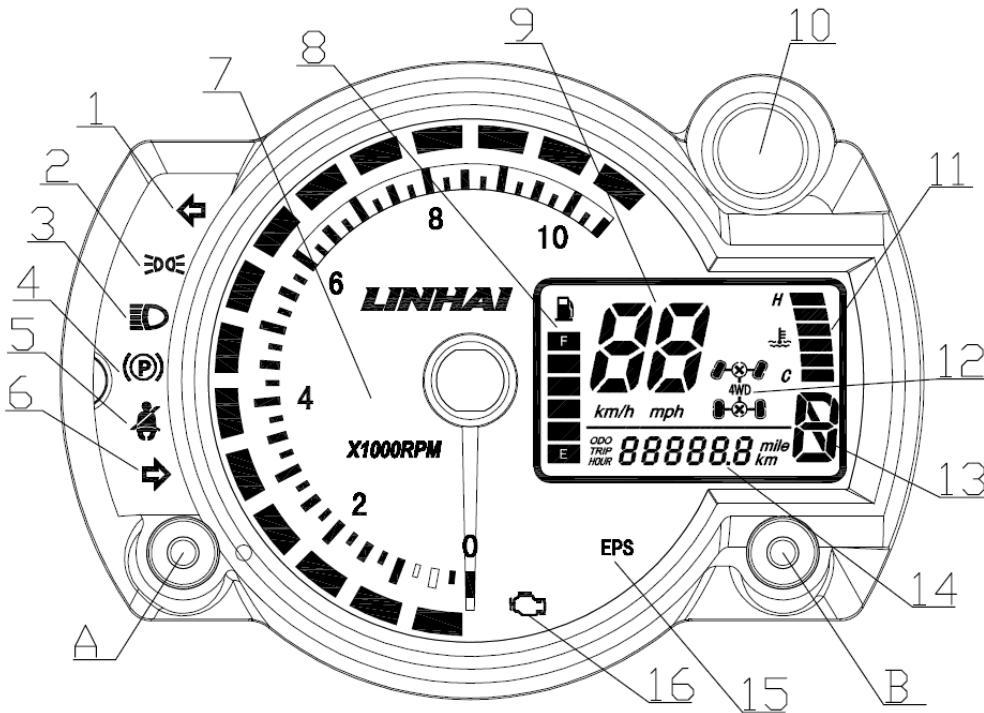

- | | |
|--------------------------------|--|
| 1. Turn Left Indicator Light | 10. Neutral Indicator |
| 2. Position Lamp Indicator | 11. Coolant Temperature Meter |
| 3. High Beam Indicator Light | 12. 2WD/4WD/DIFF Lock Indicator |
| 4. Parking Brake Indicate Lamp | 13. Gear Position Indicator |
| 5. Safety Belt Lamp | 14. The Odometer and Engine Working Hour Counter |
| 6. Turn Right Indicator Light | 15. EPS Fault Indicator |
| 7. Engine RPM Meter | 16. MIL Indicator |
| 8. Fuel Gauge Indicator | A.ODO/TRIP/HOUR Selector |
| 9. Speedometer | B.km/h、mph and km、miles Selector |

7.10 SWITCHES

Main switch

	R	R/B/Y	R	G
	○	○		
	○	○	○	○

High/Low beam switch

	BL	W	B
	○	○	○
		○	○

2WD/4WD/LOCK switch

	Red Button	Yellow Button	Gr/W	Bl/G	Br/R	Br/G	Bl/B	Br/Y	G
2WD			○	○	○				
4WD			○	○		○	○		
LOCK					○	○	○	○	○

Rear DIFF lock switch

	B1	□
OFF		
ON	○	○

turn switch

	□	Gr	LBl
	○	○	
		○	○

Optional

Horn Button

ON	○	○
OFF		

Emergency alarm switch

	□	Gr	LBl
	○	○	○
OFF			

7.11 FUEL GAUGE/ FUEL LEVEL SENSOR

EFI

Remove seat, and then remove fuel sensor attached to fuel tank

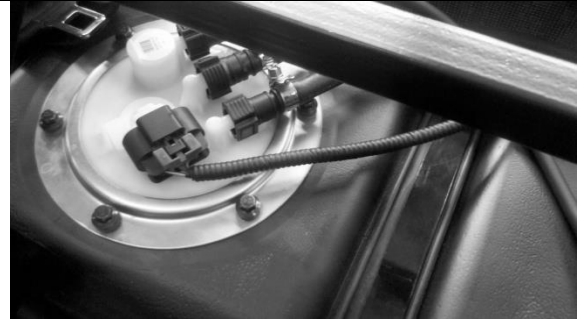

Hold fuel sensor in an upright position after removing it. It is normal if indicator shows “ E ” , otherwise, circuitry connection, fuel sensor or instrument should be inspected

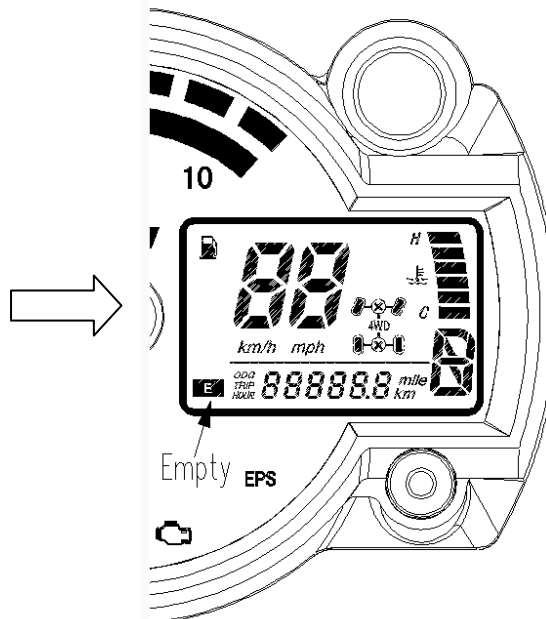

Turn fuel sensor upside down. It is normal if indicator shows “ F ” , otherwise, circuitry connection, fuel sensor or instrument should be inspected

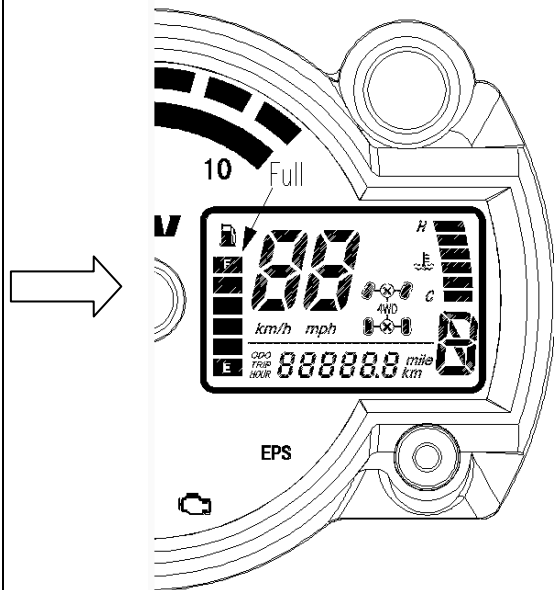

Fuel sensor resistance range

FLOAT POSITION	RESISTANCE(20°C/ 68° F)
TOP(FULL)	<16 Ω
BOTTOM(RESERVE)	>100 Ω

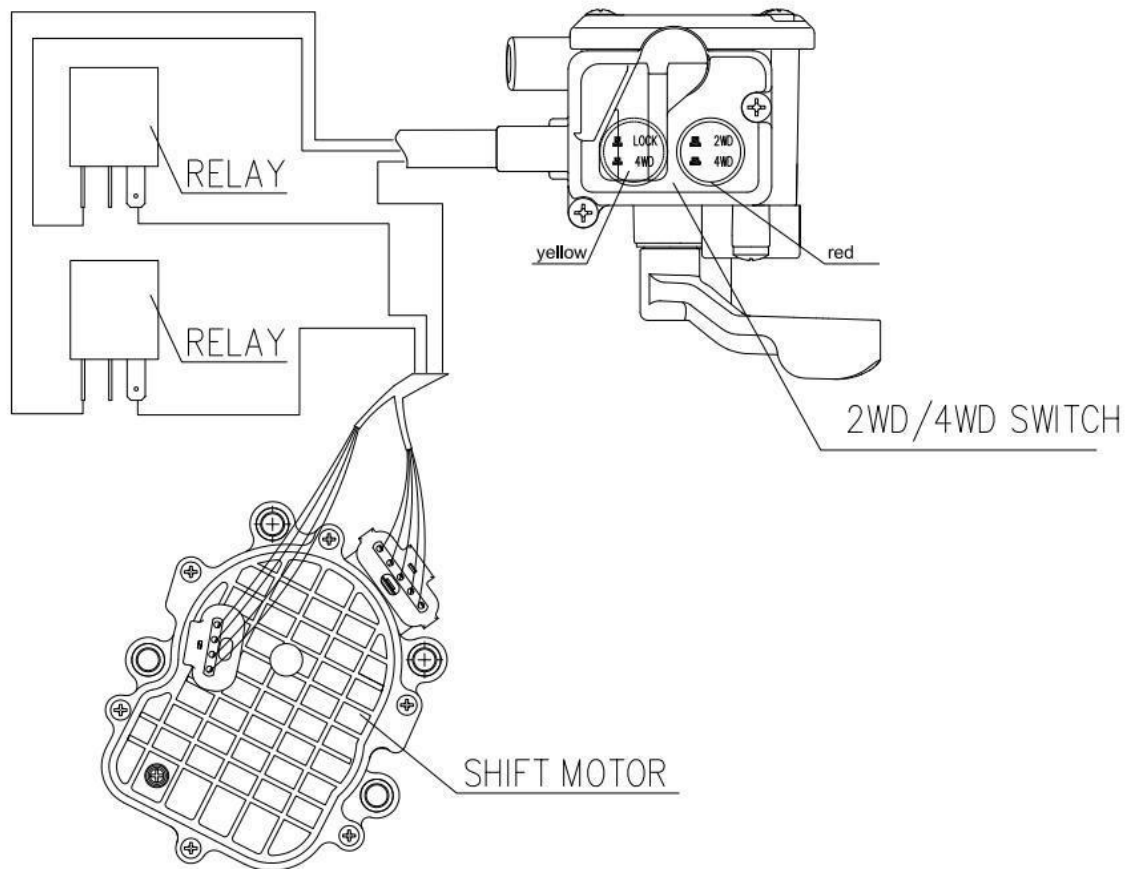
7.12 THE OPERATION PRINCIPLE OF THE ELECTRIC 4WD SHIFT

- 1, The rider shifts 2WD to 4WD by the Switch on panel.
2. When shift 2WD/ 4WD or Diff Lock, the mechanics in the front gear box maybe still engaged/ disengaged, the mechanics would finally disengaged/ engaged when rides on a hard surface or rides in reverse.
3. Always shift as the vehicle stop.

7.13 WIRING DIAGR

WIRING DIAGRAM FOR T-ARCHON 550L USA MODEL

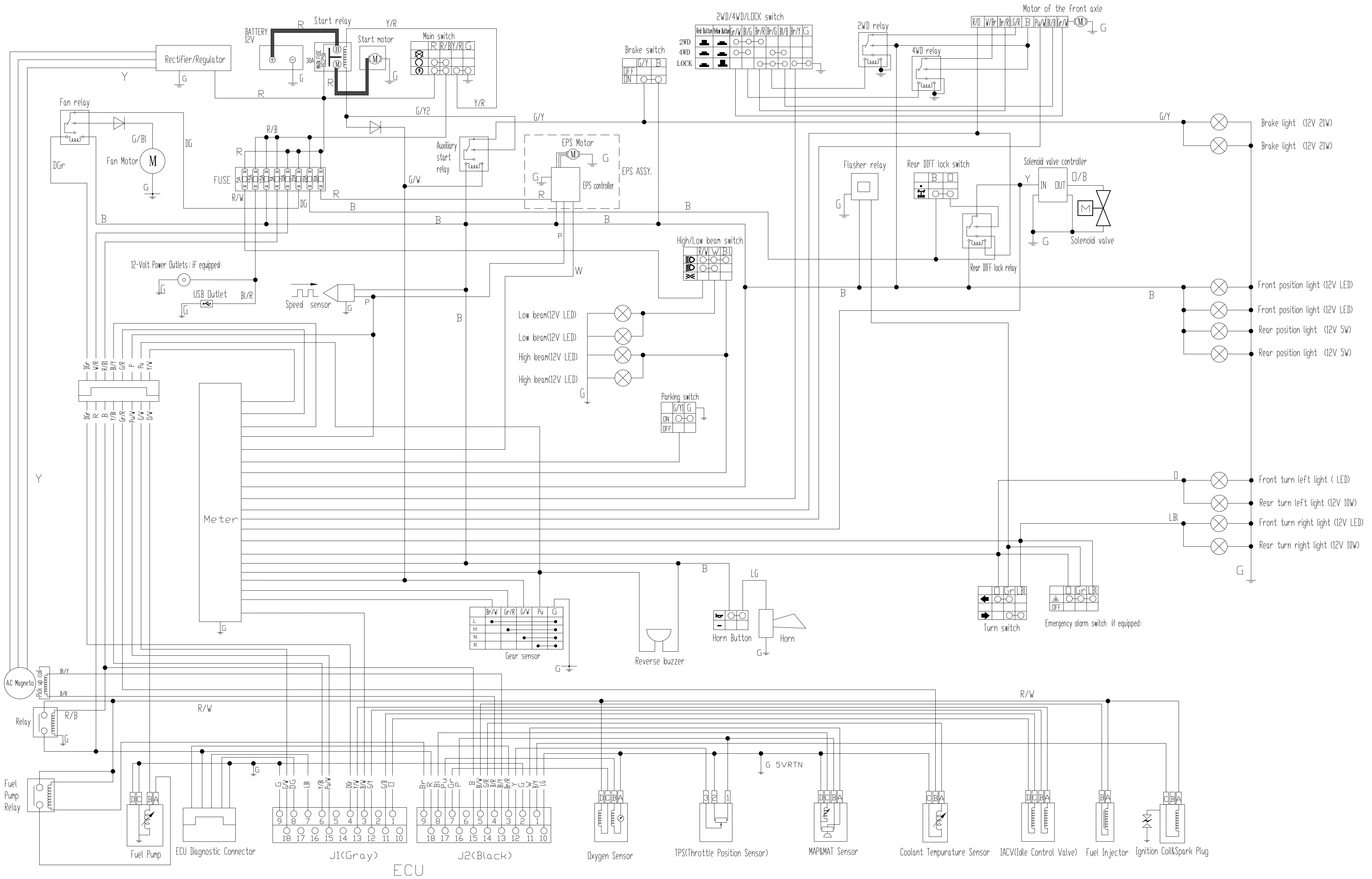

Note	Colour
B	Black
Y	Yellow
P	Pink
R	Red
Br	Brown
W	White
Bl	Blue
G	Green
G/Bl	Green/Blue
G/W	Green/White
Y/R	Yellow/Red
B/W	Black/White
Br/W	Brown/White
G/R	Green/Red
G/Y	Green/Yellow
B/R	Black/Red
Pu	Purple
B/Y	Black/Yellow
Br/R	Brown/Red
Gr	Gray
□	Orange
LG	Light green
DGr	Dark grey

- Front turn left light < LED
- Rear turn left light (12V 10W)
- Front turn right light (12V LED)
- Rear turn right light (12V 10W)