



YARD FORCE®

OUTDOOR POWER EQUIPMENT

YF4vVITA-BAT4.0

VITA BATTERY PACK

Original Instructions

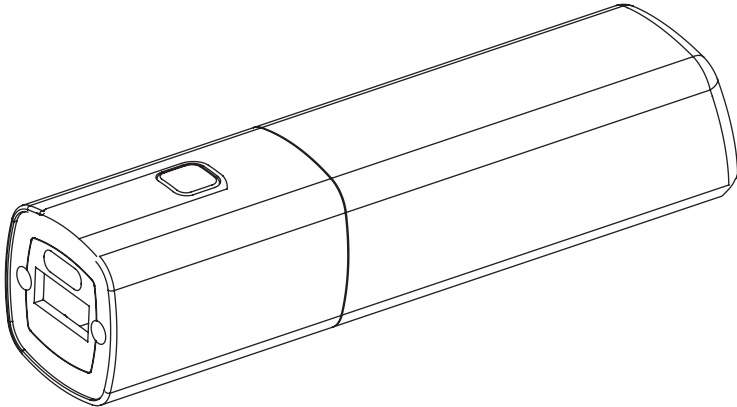

Our Customer Service staff is ready to provide assistance.

In the case of a damaged or missing part, most replacement parts ship directly from Merotec USA in Atlanta or from one of our service partners in the US.

For immediate help with assembly, or for additional product information, email support@MerotecUSA.com or call 866-902-9690 M-F 8:30am – 5:00pm ET. More information can be found on www.YardForceUSA.com.



SAVE THIS MANUAL FOR REFERENCE



You will need this manual for safety instructions, operating procedures, and Warranty.

The original sales receipt is required for warranty service.

YARD FORCE

YF4vVITA-BAT4.0 Original Instruction

CONTENT

Symbols	02
General safety warnings	04
Intended use	06
Technical data	06
Operation	06
Maintenance and storage	08
Warranty	09

SYMBOLS

Safety symbols

The purpose of safety symbols is to attract your attention to any possible dangers. The safety symbols and their explanations deserve your careful attention and full understanding. The symbol warnings do not, by themselves, eliminate any danger. The instructions and warnings they give are no substitute for proper accident prevention measures.



WARNING: Be sure to read and understand all safety instructions within this operator's manual, including all safety alert symbols such as "**DANGER**", "**WARNING**", and "**CAUTION**" before using this tool. Failure to follow all instructions listed below may result in electric shock, fire and/or serious personal injury.

SAFETY ALERT SYMBOLS: Indicate **DANGER**, **WARNING**, or **CAUTION**. May be used in conjunction with other symbols or pictographs.

Symbol meanings

This page depicts and describes safety symbols that may appear on this product. Read, fully understand and follow all instructions on the machine before attempting to assemble and operate.

SYMBOLS



To reduce the risk of injury, user must read instruction manual carefully.



Do not throw into water.



Do not throw on fire.



Do not subject the battery to strong sunlight over long periods of time. Do not leave on a heater (Max. 113°F, 45°C).



Batteries contain Li-ion. Do not dispose of waste batteries in domestic waste. Contact local authority to find out how to dispose of batteries.

GENERAL SAFETY WARNINGS

Read all safety warnings and all instructions. Failure to follow the warnings and instructions may result in electric shock, fire and/or serious injury.

Save these instructions for later use.

- These safety warnings apply only for lithium-ion batteries!
- Do not open the battery. Danger of short-circuiting.
- Whilst the battery is designed for use in all weather conditions, it is recommended to keep the contacts away from water and moisture. Contacts, which are connected though water or moisture for a longer period of time, may corrode or discharge the battery. This may result in loss of power and lifetime.
- Although the battery is suitable for use in all weather conditions, it should not be fully submerged in water, nor stored in a wet environment. Should this occur, allow battery to fully dry before reuse.
- Do not subject cells or batteries to mechanical shock.
- In case of damage and improper use of the battery, vapours may be emitted. Ventilate the area and seek medical help in case of complaints. The vapours can irritate the respiratory system.
- Use the battery only in conjunction with your VITA tools. This measure alone protects the battery against dangerous overload.
- Use only original Yard Force batteries with the voltage listed on the nameplate of your power tool. When using other batteries, e. g. imitations, reconditioned batteries or other brands, there is danger of injury as well as property damage through exploding batteries.

GENERAL SAFETY WARNINGS

- The battery can be damaged by pointed objects such as nails or screwdrivers or by force applied externally. An internal short circuit can occur and the battery can burn, smoke, explode or overheat.

Battery tool use and care

- Before any work on the machine itself (e. g. maintenance, tool change, etc.) as well as during transport and storage, remove the battery from the power tool. There is danger of injury when unintentionally actuating the ON/OFF switch.
- Recharge only with the charger specified by the manufacturer. A charger that is suitable for one type of battery pack may create a risk of fire when used with another battery pack.
- When battery pack is not in use, keep it away from other metal objects like paper clips, coins, keys, nails, screws, or other small metal objects that can make a connection from one terminal to another. Shorting the battery terminals together may cause burns or a fire.
- Under abusive conditions, liquid may be ejected from the battery; avoid contact. If contact accidentally occurs, flush with water. If liquid contacts eyes, additionally seek medical help. Liquid ejected from the battery may cause irritations or burns.

INTENDED USE

The contained lithium-ion battery is intended for use with Yard Force cordless tool and recommended for use with Yard Force VITA series battery charging wire.

TECHNICAL DATA

Battery pack Model	YF4vVITA-BAT4.0
Battery voltage	4V
Battery capacity	4.0 Ah
Output (Type A)	5V, 1A

OPERATION

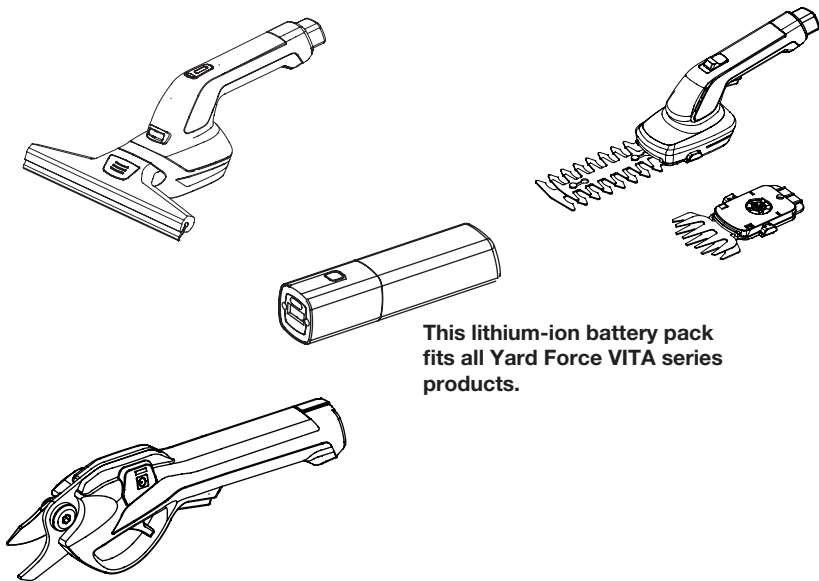

This lithium-ion battery pack fits all Yard Force VITA series products.

OPERATION

Charging the battery pack

WARNING! Do not use other charging wires which are not recommended by the manufacturer.

NOTE: The battery is supplied partially charged. To ensure full capacity of the battery, fully charge the battery before using it on the product.

1. Connect the battery with the charging wire (Type C adaptor).
2. Select an USB type A power source that is 5V 1A or less.
3. The green indicator will flash during normal charging.
4. The Indicator will show solid green when battery pack has been fully charged.

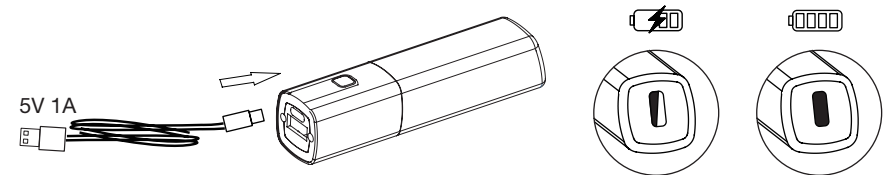

Power indicator

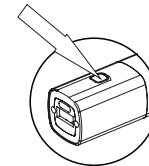

	Light up	Flasing
Green LED		
Red LED		

Using as a powerbank

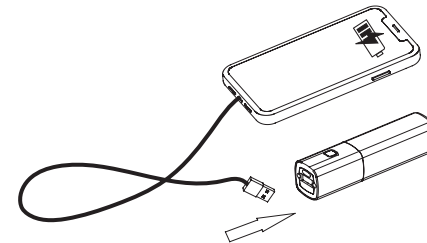

Flash light function

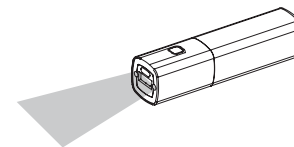

Switch ON: Press and hold the button for at least 3s. the LED Halo light will switch ON.
Switch OFF: Press and hold the button for at least 3s again. the LED Halo light will switch OFF.

MAINTENANCE AND STORAGE

To obtain the best life from the battery

1. Never allow the battery to completely discharge before recharging. The battery pack should be placed on the charger whenever the battery pack is noticeably running down or the tool no longer performs a task it previously performed.
2. Avoid conducting short charges. Make sure that the battery is fully charged each time by allowing the charger to complete its full charging cycle.
3. Avoid allowing loose items like screws or nails etc. to be stored with battery packs as these or similar items can short battery packs and cause a fire or explosion
4. Always unplug the charger when not in use and store in a dry and secure place.
5. Avoid charging or storing your battery in temperatures below 41°F or above 113°F (5°C or above 45°C).
6. After use, allow the battery to pack to cool down for approximately 30 minutes before attempting to recharge.

Maintenance and Cleaning

Occasionally clean the battery using a soft, clean and dry brush.

Transport

The contained lithium-ion battery is subject to the Dangerous Goods Legislation requirements and is suitable for ground transportation by the user without further conditions.

When being transported by third parties (e.g.: air transport or forwarding agency), special requirements on packaging and labelling must be observed. For preparation of the item being shipped, consulting an expert for hazardous material is absolutely required.

Dispatch batteries only when the housing is undamaged. Tape or mask off open contacts and pack up the battery in such a manner that it cannot move around in the packaging.

Please also observe possible additional national regulations.

Disposal

The machine, accessories and packaging should be sorted for environmental-friendly recycling.

Do not dispose of power tools and batteries/rechargeable batteries into household waste!

WARRANTY

YARD FORCE LIMITED WARRANTY STATEMENT

YARD FORCE LIMITED WARRANTY

Product Warranty

Please keep your original purchase receipt in a safe place as proof of purchase. Warranty coverage for This product must be verified by the original purchase receipt. The warranty period begins on the day the product was purchased from an authorized retailer of Yard Force products. Warranty coverage only applies to the original purchaser and is not transferable. Warranty coverage is only provided on products purchased and used in the USA and Puerto Rico from authorized Yard Force retailers. Products purchased or used outside of the USA and Puerto Rico are not covered by this warranty.

(2) Two-Year Warranty on 4v Battery Pack

Yard Force 4v Battery Pack has a Two-Year Limited Warranty from the date of purchase against manufacturer defects for residential use only. Commercial use voids the warranty. This warranty does not cover accidental damage, unreasonable use, normal wear and tear, neglect or non compliance with the Operating, Safety and Maintenance Instructions. All service, outside of normal maintenance as described in this manual, must be done by an authorized service technician. Any unauthorized service or changes to the original configuration of this product will void the warranty. All parts and accessories used on and with this product must be manufactured and/or authorized by Merotec Inc.

Warranty does not cover loss of use or other consequential damages arising from any of the above, nor does it cover repairs made or attempted by unauthorized persons. This warranty is void if the product is used for commercial, rental or industrial purposes. Certain parts, attachments and accessories are subject to normal wear and tear and are excluded from the warranty.

Service and Warranty Claims Process

Contact the Yard Force Customer Service toll-free at **(866) 902-9690 Monday-Friday between 8:30 AM and 5:00 PM** Eastern Time for service and warranty support.

Yard Force USA Service Support agents can help you troubleshoot problems over the phone to get you back up and running as quickly as possible. In the situation where service or warranty inspection is needed, please follow these steps:

1. Contact Yard Force Customer Service at **(866) 902-9690 or support@merotecusa.com Monday-Friday between 8:30 AM and 5:00 PM Eastern Time.**
2. Send in proof-of-purchase and serial number (if applicable) to confirm warranty coverage.
3. If service or a warranty evaluation is requested, Yard Force USA will provide an RGA number that should be used in all communications with Yard Force USA and if necessary, a list of local authorized service centers to bring your lawn mower to for evaluation and repair.
4. All shipments to Yard Force USA must have an RGA number. Any shipment received that does not have an RGA number clearly marked on the outside of the box will be refused.
5. All shipments must be sent pre-paid; Yard Force USA does not pay for any shipping or transportation costs for service or warranty evaluation. Yard Force USA is not responsible for any packages that are lost by carrier. We recommend that shipments are made by a carrier that provides tracking and delivery confirmation.

For more information or to ask questions, please call toll-free (866) 902-9690 or support@merotecusa.com Monday-Friday between 8:30 AM and 5:00 PM Eastern Time.



Need Help?

Please do not return the product to your place of purchase yet. We're here to help and take care of all your needs.

Contact our customer service department for help with:

- Product assembly or use
- Missing or damaged parts
- Troubleshooting
- Replacement parts and accessories

You can submit a support request by scanning the QR code on this page, or by visiting:
www.YardForceUSA.com/contact-support

Scan Code to connect with Yard Force Support



1-866-902-9690



www.YardForceUSA.com

Register your product today to maintain warranty coverage and stay up to date with information on the use, care, maintenance and service of your product.

Register online today at:

www.yardforceusa.com/product-registration



Merotec Inc.
3655 Kennesaw North Industrial Parkway
Kennesaw, GA 30144
Copyright © 2022 Merotec Inc.

Made in China at a SUMEC manufacturing facility.

Part Number: YF4vVITA-BAT4.0MAN-A
2209