

OPERATION

Control panel

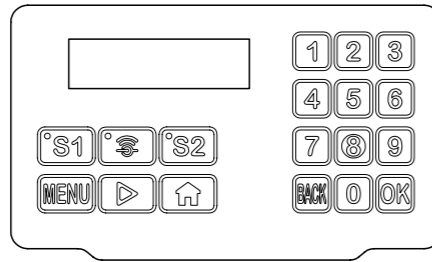

Initial interface

when power on your robotic mower, after entering the default PIN 0000, you will see the initial interface on the display.

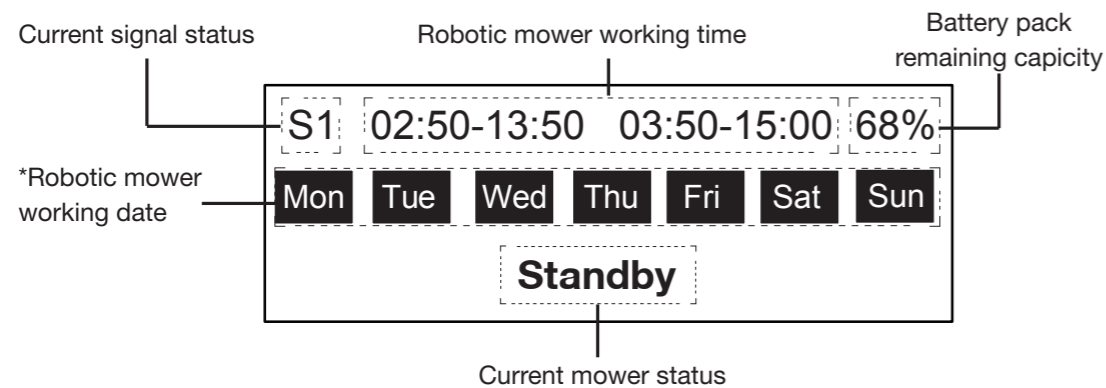
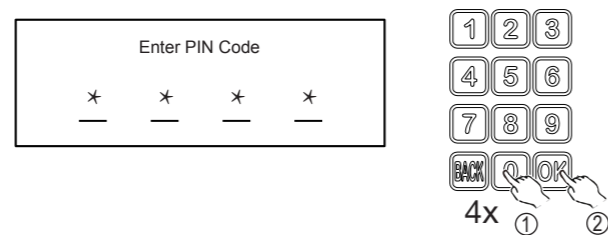

*NOTE: Inverted color means date was selected.



OPERATION

Before starting your robotic mower

Please follow below steps to adjust the time setting before starting your robotic mower.

1. Press the **MENU** button to enter the menu setting.

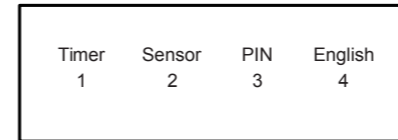

2. Press the **1** button to enter time setting.

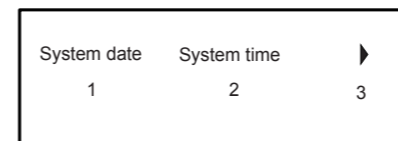

3. Press the **1** button to set the system date

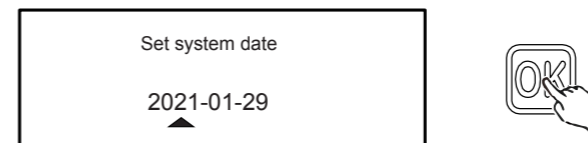

4. Press the **2** button to set the system time

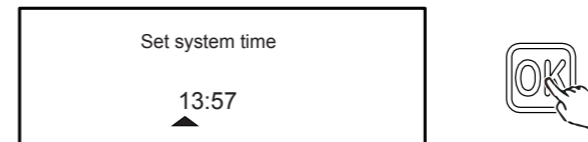

5. Press the **3** button to enter next page

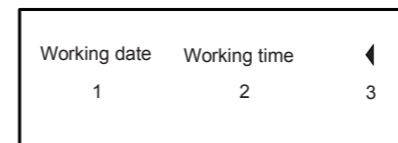

6. Press the **1** button to set the working date

- Press the relative numbers to select the working date your required.

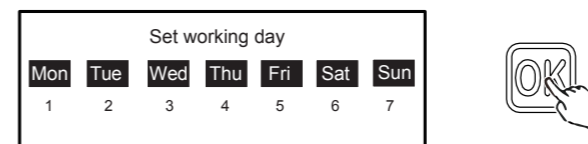

7. Press the **2** button to set the working time

- Press the relative numbers to select the working time your required.

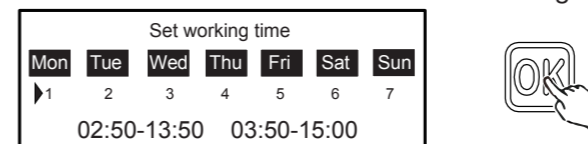

NOTE: If the working day is activated, then the blinking cursor will move to specified time setting.

OPERATION

Sensor setting

1. Press the **MENU** button to enter the menu setting.

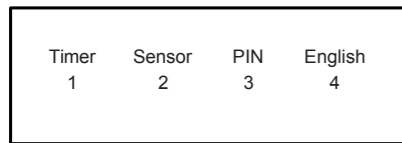

2. Press the **2** button to enter the sensor setting.

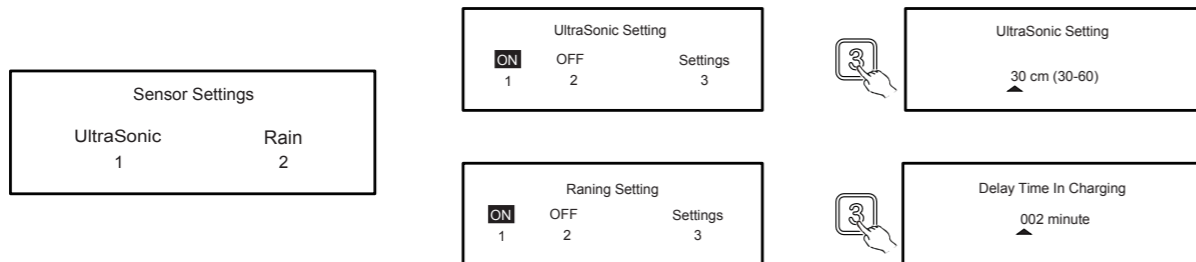

- UltraSonic sensor

This machine equipped 2 ultrasonic sensors which may detect the obstacle on the lawn. When the sensor is activated, the robot will stop and then turn around when detect an obstacle.

Press **2** to switch off the sensor.

Press **3** to elect the detect distance you require.

- Rain sensor

NOTE: Mowing in the rain is not recommended.

This machine has a rain sensor which may stop the robot from mowing in the rain. When the rain sensor is triggered, the robot will go back to the charging station first, where it will be fully charged. Once charged the mower will remain in the charging station until the rain has stopped before starting to mow again.

Note: Be careful not to short circuit the sensors on the machine with any metal objects. This will cause the mower to work abnormally.

Press **2** to switch off the sensor.

Press **3** to set the extra time.

PIN code

1. Press the **MENU** button to enter the menu setting.

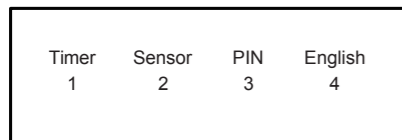

2. Press the **3** button to enter the PIN setting.

- This option sets the passcode of the mower to prevent theft or unauthorised change of the menu settings. The existing (old) passcode is required to change to a new passcode. If you have forgotten the passcode, contact your local dealer or after sales service.

The default passcode of the mower is "0000".

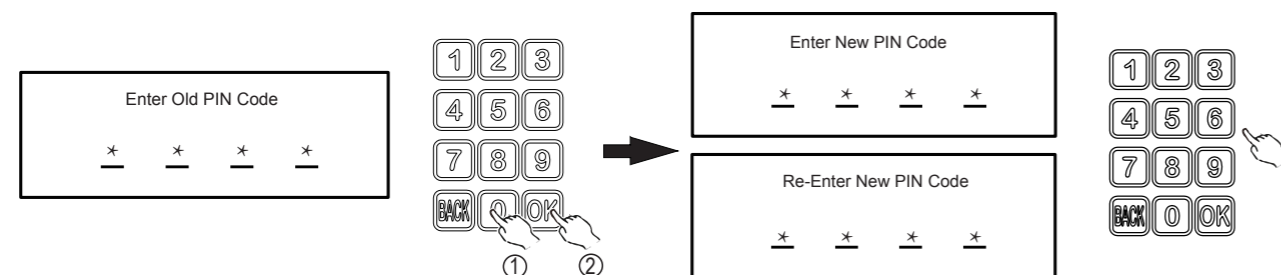

OPERATION

- After re- enter the new PIN, press **OK** button complete this setting.

Language

1. Press the **MENU** button to enter the menu setting.

2. Select related number to set the language you require.



WiFi settings

Press the **MENU** button to enter the menu setting.

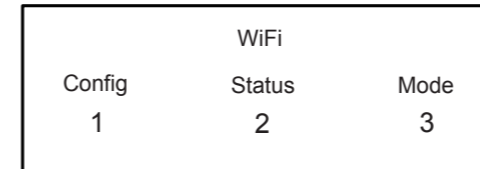

There are 3 further options in "WiFi".

Config

Select this option when you need to connect you mower to APP, see **APP manual**

Status

Show currently WiFi status

Mode

Client Mode-Default mode

Direct Mode-select this mode when you choose direct mode connection you **on your phone**.

Signal setting

- Set you require signal by pressing S1 or S2 button.

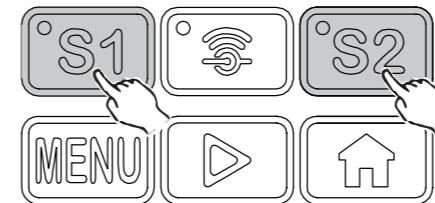

OPERATION

Cutting height adjustment

The cutting height can be adjusted by rotating the height adjustment dial located on the top of the machine. Cutting height range from 1-1/3"-3".

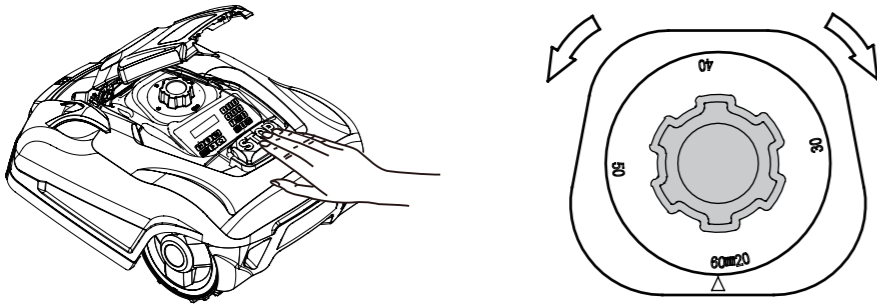

NOTE!

We recommend using an ordinary lawn mower or trimmer to cut the lawn below 2.5 in before using the Robotic Mower. This will ensure you get the optimum performance.





Start mowing

After finishing the time settings, now you can start your Robotic Mower

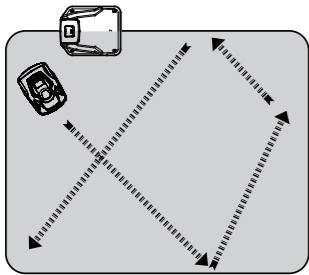
1. Press the  button for 4 times to unlock the panel.
2. Press the button  and then close the lid, the Robotic Mower will start to work.



Return to the docking station

1. Press the  button for 4 times to unlock the panel.
2. Press the button  and then close the lid, the Robotic Mower will back to the docking station.

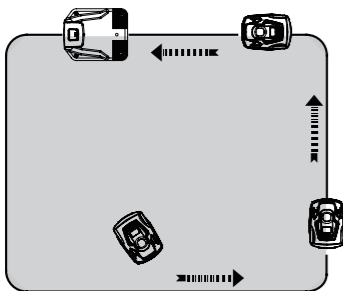

Emergency Stop

Press STOP button to halt the mower at any time.



MAINTENANCE AND STORAGE

Maintenance work that has not been described in these instructions must be carried out by a servicing agency authorised by the manufacturer. Only use original parts.

Maintenance

Check and clean your Robotic Mower regularly and replace worn parts if necessary. Preferably use a dry brush, a damp cloth or a sharpened wooden piece.

Never use flushing water.

Following these maintenance instructions can extend your Robotic Mower's service life.

Battery Life

The Robotic Mower has a maintenance free Li-ion battery, with an estimated life of more than 2 years (depending on treatment and usage).

Winter Storage

During winter, keep your mower, docking station and power supply in a dry place.

We recommend a shed, garage or preferably store it indoors.

Prepare your device for winter storage as follows:

1. Fully recharge the battery.
2. Set the mains power switch to "OFF".
3. Thoroughly clean your Robotic Mower.
4. Unplug the power supply from the mains outlet.
5. Disconnect the power supply from the docking station.
6. Disconnect the boundary wire from the docking station. Lift up the docking station and clean. The boundary wire can remain outside. However, it is imperative to protect the wire against corrosion. We recommend a water-free grease or suitable sealing tape.

If available, repack the product in the original packaging.

Alternatively, our service centre offers a winter service for your device. This will include a check-up of all parts and - if available - a software upgrade.

Preparing for spring

After winter storage, please clean the charging contacts on both the Robotic Mower and the docking station.

Use a fine abrasion paper or a brass brush; this will help to achieve the best charging efficiency and avoid any charging interference.

Cleaning the mower body

As your Robotic Mower is battery powered you need take care when cleaning. Remove rough dirt with a soft brush. Use a manual water spray with mild household detergent for intensive cleaning. Wipe off any residue after cleaning with a moist rag.

Disposal

To help the environment, please dispose of the product properly when it has reached the end of its useful life and not in the household waste. Information on collection points and their opening hours can be obtained from your local authority.

Li-Ion environmental damage through incorrect disposal of the batteries / rechargeable batteries.

Remove the battery pack from the product before disposal. Batteries /rechargeable batteries may not be disposed of with the usual domestic waste. They may contain toxic heavy metals and are subject to hazardous waste treatment rules and regulations. Please dispose of batteries according to the relevant local requirements.

Replacing the battery

While the actual battery life will depend on usage and environmental factors, the typical service life is several years. Spare batteries are available from customer support. To replace the battery, please follow the instructions below.

MAINTENANCE AND STORAGE

1. Ensure the main power switch is turned OFF. Clean the underside as instructed.
2. Set the Autonomous Mower to the lowest cutting height.
3. Turn the mower upside-down. Remove the 5 screws fixing the battery compartment's lid. Note one screw is partially covered by the blade protector and is only accessible through a service hole.
4. Pull out the battery and disconnect it from the Autonomous Mower.
5. Carefully clean the lid and the edge of the battery compartment. Debris may allow excessive water to enter the battery compartment, causing major damage to the appliance.
6. Connect and insert the replacement battery, close the compartment and fix the lid with 5 screws. Do not turn on the Autonomous Mower before placing it back on its wheels. Beware of sharp blades!

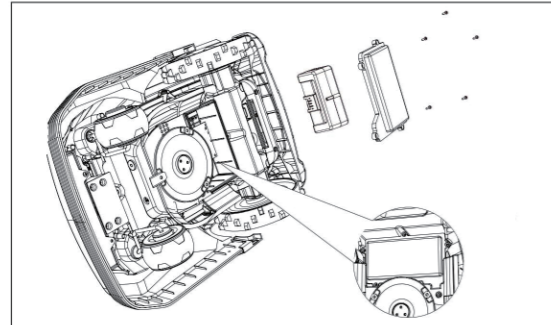

Cleaning the underside

Ensure the main power switch is in OFF position. Wearing protective gloves, turn the Robotic Mower onto its side to expose its underside. Clean the blade disc and frame using a soft brush or damp cloth. Rotate the blade disc to make sure that it can move freely, check that the blades can turn on their pivots and that there is no grass is obstructing them.

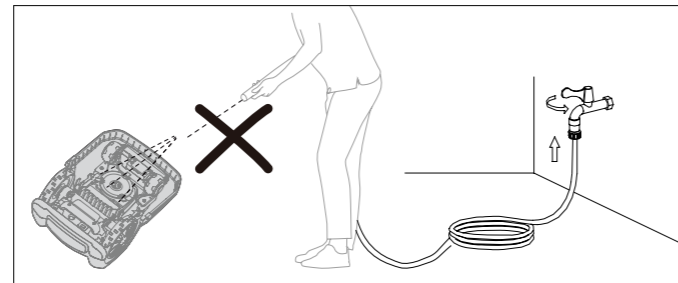
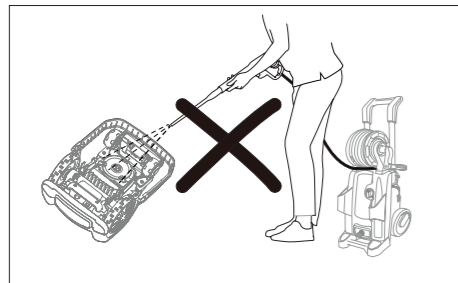

Clean the contact pins and the charging strips

Using wire wool, metal cleaner or very fine grade emery paper, clean the contact pins and the charging strips on your mower and docking station. Remove any debris, leaves, or grass clippings around the contact pins and charging strips to ensure efficient charging.

Reversing or replacing the blades

⚠ WARNING !

Ensure the Robotic Mower is completely shut off before cleaning, adjusting or replacing the blades. Always wear protective gloves.

⚠ WARNING !

To ensure maximum cutting efficiency and safety, always use recommended replacement blades and blade mounting parts when replacing.

MAINTENANCE AND STORAGE

Your Robotic Mower has three blades, fixed to the blades disk. Unless damaged by hard obstacles, these blades can last for up to five months of everyday use. Weekly inspection of the blades and the fixing screws is advised. Note that the blades are double-edged. When the first side becomes blunt, loosen the fixing screw and the blade upside down and re-fix. Check that the blade can move freely.

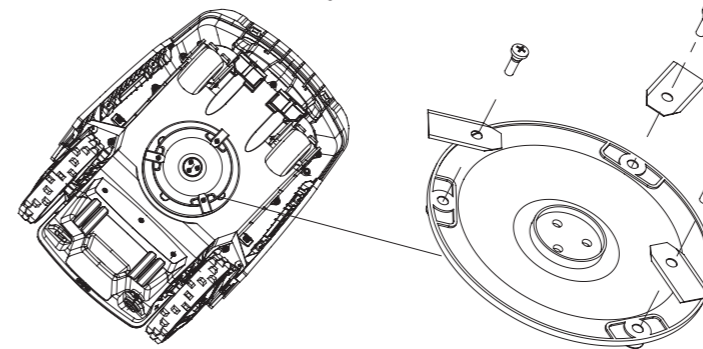

A set of spare blades is included with the Robotic Mower. More blades can be purchased via customer support.

To ensure you get the best performance from your machine, always replace all three blades at the same time. Only use spare parts recommended by manufacturer.

NOTE: if blades have been removed/ changed, please ensure that the screw is firmly secured in place and that the blade is free to move.

Spare parts list

In case you need spare parts or any support with your device, please call our after sales centre.

