

# OWNER'S MANUAL

## Model: 3PT-300-8R-2BB (5303772)

(300 Gallon 3-Point Sprayer w/Broadcast Boom Assembly & Handgun)  
(Pump & Coupler Included)

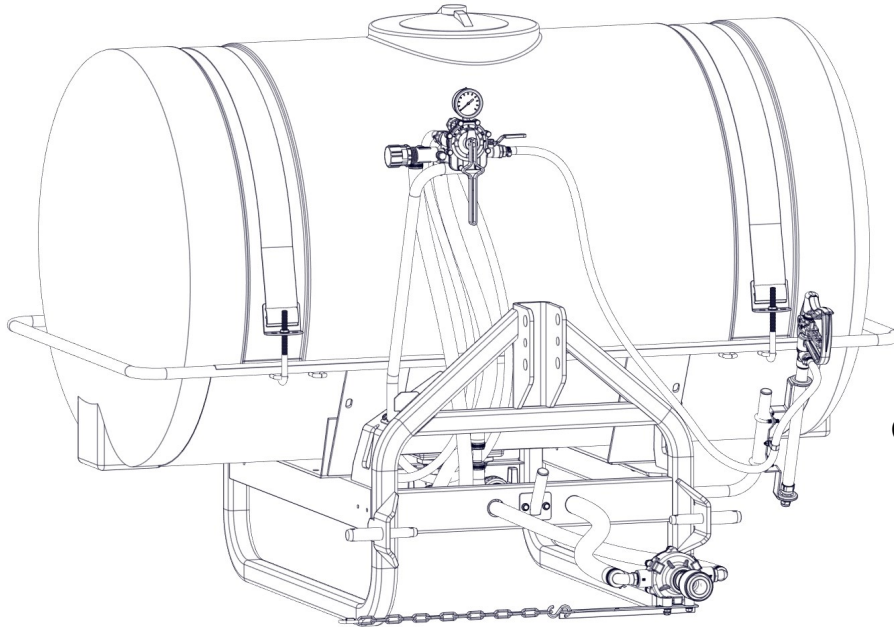

Category I, II or III

### General Information

Thank you for purchasing this product. The purpose of this manual is to assist you in operating and maintaining your 3 Point sprayer.

**BEFORE RETURNING THIS PRODUCT  
FOR ANY REASON, PLEASE CALL**

**1-800-831-0027**

MONDAY-FRIDAY, 8:00 AM TO 5:00 PM CST

If you should have a question or experience a problem with your Fimco Industries Product: Visit our website @ [www.fimcoindustries.com](http://www.fimcoindustries.com) or call the Toll free number above. Our technical support representatives will be happy to help you.

In most cases a customer service rep. can resolve the problem over the phone.

To obtain prompt, efficient service, always remember to give the following information....

- Correct Part Description and/or part number
- Model number and Serial Number

Part descriptions and numbers can be obtained from the illustrated parts list section(s) of this manual.



**WARNING:** Cancer and Reproductive Harm.  
[www.P65Warnings.ca.gov](http://www.P65Warnings.ca.gov)



**WARNING:** To reduce the risk of injury, the user must read and understand the operator's manual before using this product.

**Retain a copy of your receipt for your unit, as it will be required to validate any warranty service.**

**Warranted against manufacturer or workmanship defects from date of purchase with copy of receipt:**

**Homeowner Usage: One Year**

**Commercial Usage: 90 Days.**



**[www.fimcoindustries.com](http://www.fimcoindustries.com)**

1000 FIMCO Lane, P.O. Box 1700, North Sioux City, SD 57049  
Toll Free Phone: 800-831-0027 : Toll Free Fax: 800-494-0440  
[5195954 (10/23)]

## Contents

Technical Specs.....	2	Sprayer Parts List.....	11
Sprayer Assembly Instructions .....	3 - 4	Pressure Relief Valve Exploded View/Parts List.....	14
Boom Assembly Instructions .....	5	Directo Valve Exploded View/Parts List .....	14
Operation and Calibration .....	6 - 7	High Pressure Spray Gun Info.....	15
Maintenance and Tank Care.....	8	Roller Pump Exploded View/Parts List .....	15
Winter Storage .....	9	Roller Pump Gen. Info/Operations/Maintenance.....	16
Troubleshooting .....	9	Dimensions.....	17
Sprayer Exploded Views .....	10 - 13	Warranty .....	18

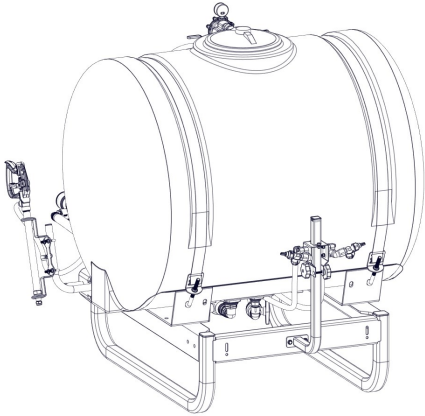

## Model: 3PT-300-8R-2BB (5303772) (300 Gallon 3-Point Sprayer w/Broadcast Boom Assembly) (Pump & Coupler Included)

### Technical Specifications

- 300 Gallon Polyethylene Tank
- Suction Line Filter
- Broadcast Boom Assembly
- 8-Roller Pump & Coupler
- 22" High Pressure Spray Gun

**Caution: When fully filled with water, this sprayer will weigh approx. 2,945 lbs..**  
**Consult the owner's manual for your vehicle to verify that you are within it's load carrying capacity.**

### ~~~~~IMPORTANT~~~~~

Remove tank lid and be sure the tank is clean and free of any foreign material. Rinse tank out of any tank residue before filling with water to test.

### ~~~~~IMPORTANT~~~~~

It is VERY important for you to test your sprayer with plain water before actual spraying is attempted. This will enable you to check the sprayer for leaks without the possibility of losing any expensive chemicals.

### ~~~~~WARNING~~~~~



**Read and Understand the Owner's Manual** before using this sprayer. Test and use in accordance to instructions.  
**Read and Follow** chemical label instructions and wear protective gear when filling, using, cleaning and servicing the sprayer.

**Exercise Caution** in vehicle handling when towing/hauling a filled sprayer to avoid loss of control or overturning.

**Keep Sprayer and Spray materials** away from other people, children and pets.

**Do Not Turn on Power** to the sprayer, until ready to spray in order to avoid unintentional spray release.

**Do Not Use** on steep slopes. A full sprayer could cause loss of control or overturn sprayer and vehicle.

**Always operate** up and down a slope, never across the face of a slope.

**Keep all movement on slopes** slow and gradual. Do not make sudden changes in speed, directions or turning. Do not start or stop suddenly when going uphill or downhill.

**Stop on level ground**, set the parking brake and shut off engine before leaving the operator's position for any reason.

**Keep all parts** in good condition and properly installed. Fix damaged or worn parts immediately.

**Caution should be taken** when towing and/or using any sprayer. This sprayer combined with the weight distribution, turning radius and speed of vehicle can result in damage to vehicle and/or sprayer or severe injury or death, if not used properly.

**Improper use of this sprayer or handling of chemicals could result in serious injury or illness, or could cause damage to the environment.**

## Assembly Procedure

Most of the sprayer has been assembled at the factory.

- Follow these steps to properly assemble the sprayer.

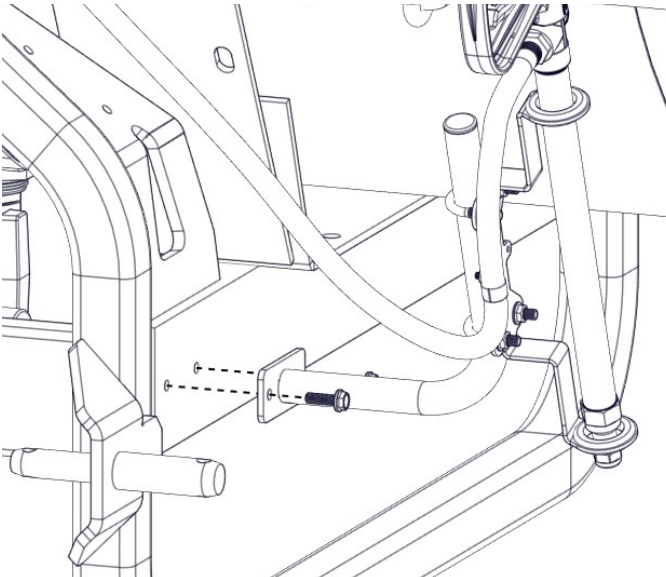

1. Install the hose wrap mount (handgun/hose bracket will already be attached to the mount) to the sprayer frame using (2) bolts and nuts.

2. Attach the Manifold Bracket to the 3PT Frame using (2) bolts and nuts. The 3PT Manifold will already be attached to the top of the bracket.

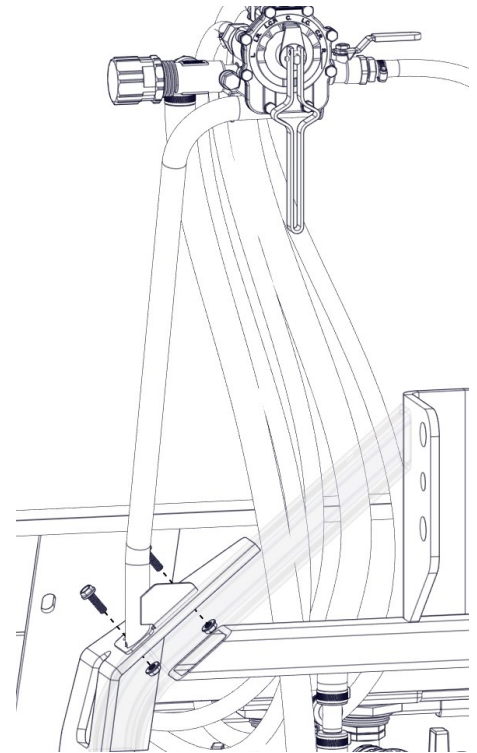
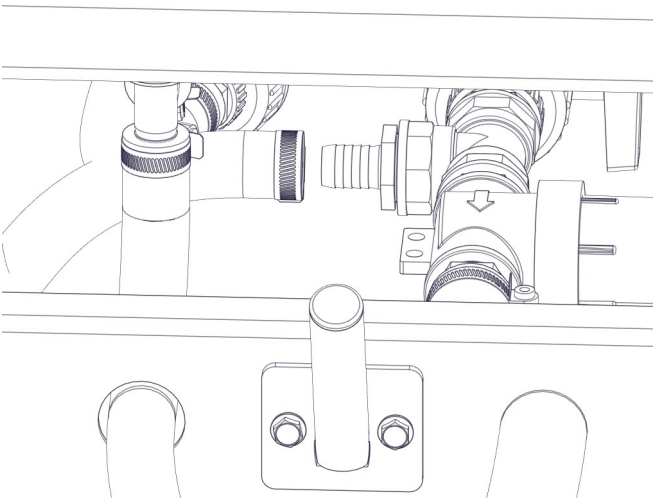

3. Connect the 3/4" x 42" bypass hose to the 3/4" hose barb on the strainer assembly and tighten hose using a 3/4" hose clamp from the parts bag. The hose will already be secured to the valve manifold by the factory.

4. Connect the 3/4" x 32" feeder hose to the 3/4" Tee fitting and tighten hose using a 3/4" hose clamp from the parts bag. The hose will already be secured to the valve manifold by the factory.

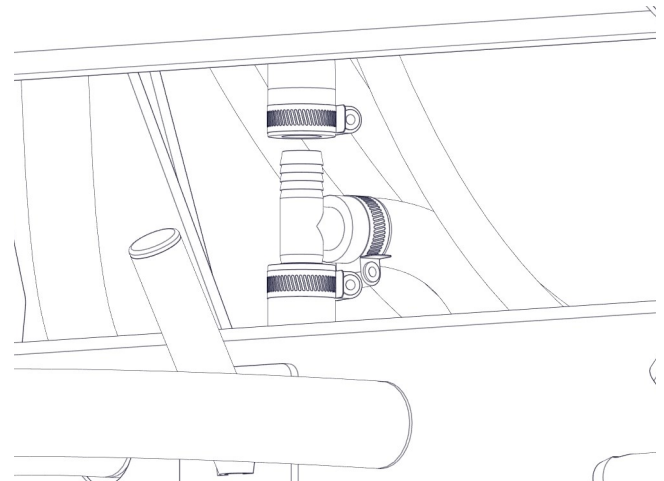

## Assembly Procedure

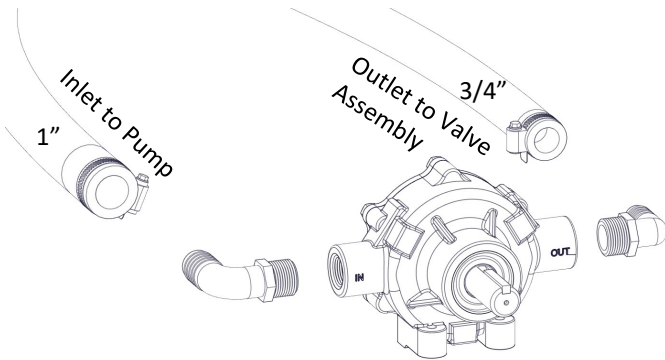

Pump IS included with this Sprayer - for Reference ONLY

5. Using a good quality thread sealant, thread 1" fitting into the inlet (IN) and 3/4" fitting into the outlet (OUT) sides of the pump. Slip a 1" hose clamp on to the 1" inlet hose (coming from the strainer) and with a twisting motion, attach to the fitting on the inlet side of the pump. Then slip a 3/4" hose clamp onto the 3/4" hose (coming off the valve assembly) and with a twisting motion attach to the fitting on the outlet side of the pump. Secure the hose clamps.

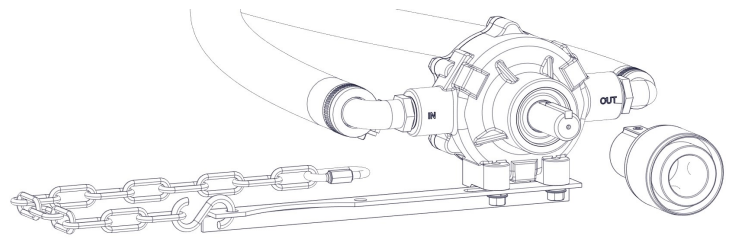

6. The roller pump IS included with the assembly. Attach the adapter, the torque bracket, torque chain, S-hook, lock washers, hex bolts and the rapid/quick link to the pump as needed. It is intended for your pump to be mounted directly to the tractor PTO. The torque chain needs to be secured to the tractor to keep your pump from spinning.

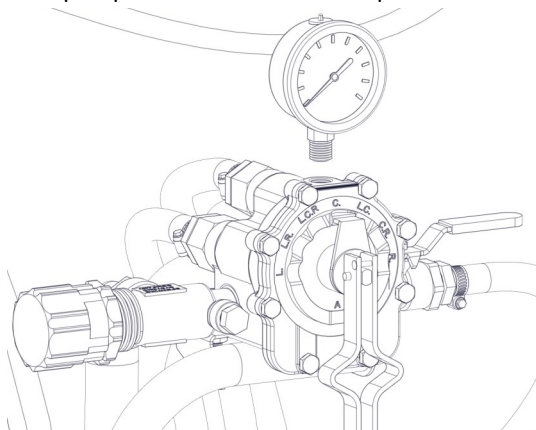

7. Using a sealant or plumber's Teflon tape, thread the gauge into the top of the tee valve assembly.

### Hole #3:

This is for CAT III narrow quick attach. Also use the outer lower link pins.

### Hole #2:

This is for CAT I Direct Connection.  
Also use of inner lower link pins.

### Hole #1:

This is for CAT II Direct Connection and CAT II Quick Hitch.  
Also use of outer lower link pins.

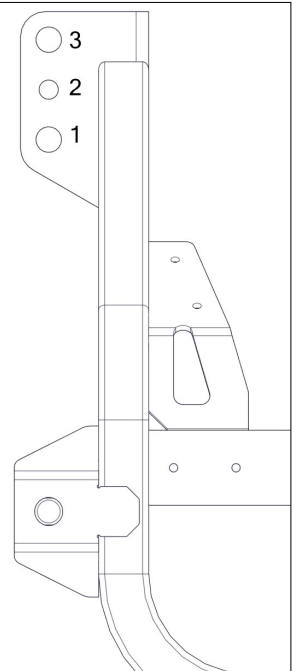

## Boom Assembly Procedure

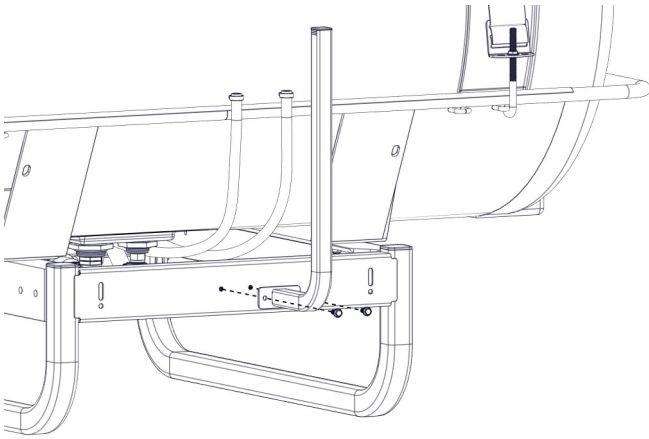

1. Attach the Upright Boom Mount to the 3PT tube frame, using (2) hex bolts and (2) nuts.

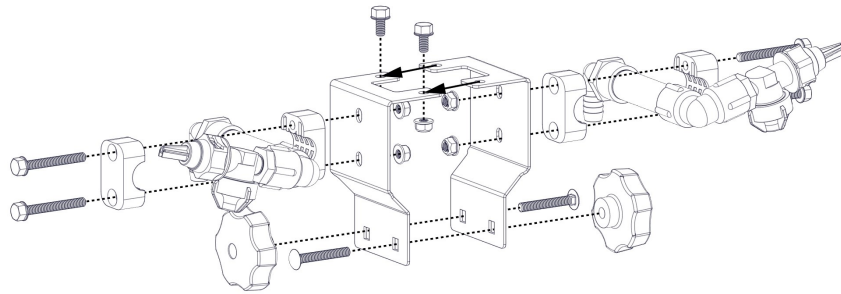

2. Assemble the Broadcast Nozzle Mounts and Nozzles, as shown, if not already done.

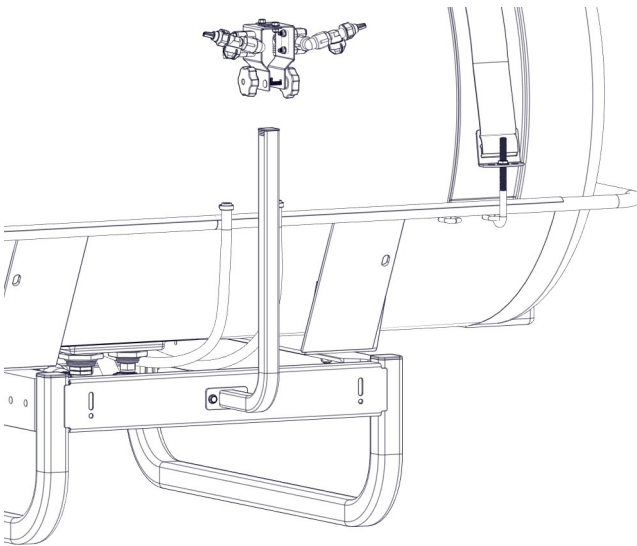

3. Mount the assembled nozzle mounts and nozzles to the upright boom mount. Slip (2) 1/2" hose clamps on to the feeder hoses coming from the valve assembly. With a twisting motion, slide feeder hoses all the way on to the hose bars and secure with hose clamps. Install the plug (see below).

- Make sure all hose clamps are tight before testing or spraying for the first time.

**\*\*Sprayer is now ready to Test w/plain water before actual use\*\***

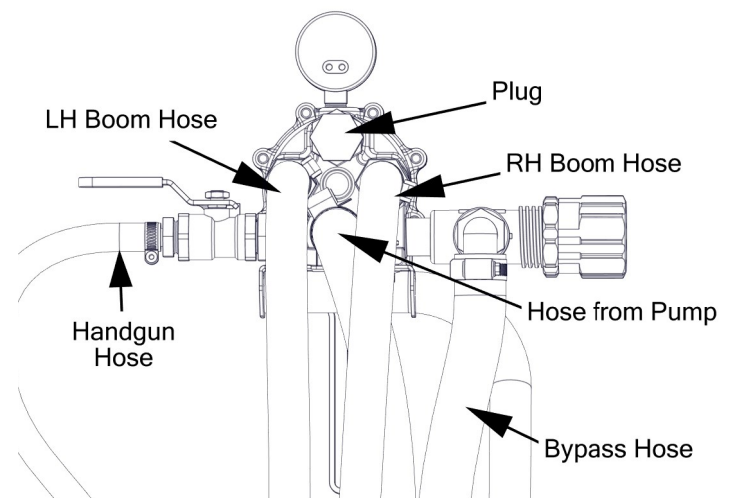

# Operation Instructions

## Information About the Sprayer

Roller pumps are positive displacement pumps, which means that the entire solution being pumped must go somewhere or the pump will break. In this roller pumping system, solution is drawn from the tank and forced to a planned source, such as boom nozzles or handgun. The pressure is controlled by a pressure relief valve, which is a spring-loaded device that controls the amount of fluid bypassed (recirculated) to the tank. The gray handle is to be tightened to increase pressure and loosened to decrease pressure. The 'directo-valve' is the on/off control which allows the operator to manually control the solution going to the boom.

**IMPORTANT:** Remove tank lid and be sure the tank is clean and free of any foreign material. Rinse tank out of any tank residue before filling with water to test.

**Only fill the tank with what you're going to spray in a day, never leave chemicals sit in tank.**

## Testing the Sprayer

Attach the sprayer to the tractor 3 point hitch. Mount the pump to the PTO and affix the torque chain.

**NOTE:** It is important to test the sprayer with plain water before actual spraying is attempted. This will enable you to familiarize yourself and check for leaks without the possibility of losing any expensive chemicals.

Fill the tank about 1/2 full with plain water. Before starting, open the suction line valve (located underneath the carrier frame), turn the relief valve handle out to lower the line pressure. This will help prime the pump.

**CAUTION:** Always be sure that the water (or solution) has reached the pump before starting your sprayer. If the pump is allowed to run dry, serious damage to the pump will result.

Always have the pressure line open to the tips so that the air which may be trapped in the line will be forced (or purged) out. Start the tractor PTO. Check the entire system for leaks. Once the pump is primed, the pressure may be increased by turning the handle of the pressure relief valve in. Keep the pressure line open to the tips when setting the pressure. Set the pressure and then lock the relief valve handle in place. Shut off the directo-valve and check for leaks again. Pressure will increase when the pressure line valve is closed and then return to the preset pressure when the valve is opened again.

During the testing period, be sure to observe the spray pattern given by the spray nozzles. If there is any pattern distortion, it will be necessary to remove and clean the affected tips.

**Caution:** Never use a metal object or other sharp item for cleaning a nozzle tip. It is better to use a nozzle brush (NOT wire brush) or compressed air for tip cleaning.

Conditions of weather and terrain must be considered when setting the sprayer. Do not spray on windy days. Protective clothing must be worn in some cases

**Be sure to read the chemical label(s) before application!**

## Calibration

Chemical labels may show application rates in gallons per acre, gallons per 1000 square feet or gallons per 100 square feet. You will note that the tip chart, next page, shows 2 of these rating systems. Once you know how much you are going to spray, then determine (from the tip chart) the spraying pressure (PSI), and the spraying speed (MPH).

Determining the proper speed of the pulling vehicle can be done by marking off 100, 200 & 300 feet. The speed chart indicates the number of seconds it takes to travel the distances. Set the throttle and with a running start, travel the distances. Adjust the throttle until you travel the distances in the number of seconds indicated by the speed chart. Once you have reached the throttle setting needed, mark the throttle location so you can stop and go again, returning to the same speed.

Add water and proper amount of chemical to the tank and drive to the starting place for spraying.

## Using the Boom Nozzles

Four things must be considered before spraying with the boom.

1. How much chemical must be mixed in the tank.
  2. Rate of spray (gallons per acre to be sprayed).
  3. What pressure (p.s.i.) will be used.
  4. Speed traveled (mph) while spraying.
- \* Refer to the chemical label to determine your chemical mixture
  - \* See the tip chart to determine the pressure to be used. The chart will also show the speed used when spraying.
  - \* Start the pump and open the valve to the boom nozzles.
  - \* Check the spray pattern. Usually you can see the coverage better on a solid concrete surface, such as a driveway.

Speed Chart			
Speed in M.P.H. (Miles Per Hour)	Time Required in seconds to travel a distance of		
	100 Ft.	200 Ft.	300 Ft.
1.0	68 sec.	136	205
2.0	34	68	102
3.0	23	45	68
4.0	17	34	51
5.0	14	27	41
6.0	11	23	34
7.0	9.7	19	29
8.0	8.5	17	26
9.0	7.6	15	23
10.0	6.8	14	20

Broadcast spray nozzles are great for rough terrains, road side spraying, fence rows and other areas that are difficult to apply with a traditional boom.

BROADCAST & TURF APPLICATIONS				Gallons per Acre												GAL/1000 Sq. Ft.				Swath Width (Ft) @ 40 PSI
				MPH												MPH				
Thread	XT Model	PSI	GPM	4	5	6	7	8	10	12	14	16	18	20	2	3	4	5		
1/4" MNPT	XT010 GREEN	30	0.9	7.0	5.6	4.6	4.0	3.5	2.8	2.3	2.0	1.7	1.5	1.4	0.32	0.21	0.16	0.13	16	
		40	1.0	7.7	6.2	5.2	4.4	3.9	3.1	2.6	2.2	1.9	1.7	1.5	0.36	0.24	0.18	0.14		
		50	1.1	8.8	6.8	5.7	4.9	4.3	3.4	2.8	2.4	2.1	1.9	1.7	0.39	0.26	0.20	0.16		
		60	1.2	9.3	7.4	6.2	5.3	4.6	3.7	3.1	2.7	2.3	2.1	1.9	0.43	0.28	0.21	0.17		
1/4" MNPT	XT020 FC-XT020 BLUE	30	1.7	12.4	9.9	8.3	7.1	6.2	5.0	4.1	3.5	3.1	2.8	2.5	0.57	0.38	0.28	0.23	17	
		40	2.0	14.6	11.6	9.7	8.3	7.3	5.8	4.9	4.2	3.6	3.2	2.9	0.67	0.45	0.33	0.27		
		50	2.2	16.0	12.8	10.7	9.2	8.0	6.4	5.3	4.6	4.0	3.6	3.2	0.74	0.49	0.37	0.29		
		60	2.4	17.5	14.0	11.6	10.0	8.7	7.0	5.8	5.0	4.4	3.9	3.5	0.80	0.53	0.40	0.32		
1/4" MNPT	XT024 FC-XT024 YELLOW	30	2.1	14.3	11.4	9.5	8.2	7.1	5.7	4.8	4.1	3.6	3.2	2.9	0.65	0.44	0.33	0.26	18	
		40	2.4	16.5	13.2	11.0	9.4	8.3	6.6	5.5	4.7	4.1	3.7	3.3	0.76	0.50	0.38	0.30		
		50	2.7	18.0	14.8	12.3	10.5	9.2	7.4	6.1	5.3	4.6	4.1	3.7	0.84	0.56	0.42	0.34		
		60	2.9	20.0	16.2	13.5	11.5	10.1	8.1	6.7	5.8	5.1	4.5	4.0	1.0	0.65	0.49	0.39		
3/8" MNPT	XT043 FC-XT043 ORANGE	30	3.7	25.0	20.0	17.0	14.5	12.7	10.2	8.5	7.3	6.4	5.7	5.1	1.2	0.78	0.58	0.47	18	
		40	4.3	30.0	24.0	19.7	16.9	14.8	11.8	9.9	8.4	7.4	6.6	5.9	1.4	0.90	0.68	0.54		
		50	4.8	33.0	26.0	22.0	18.9	16.5	13.2	11.0	9.4	8.3	7.3	6.6	1.5	1.0	0.76	0.61		
		60	5.3	36.0	29.0	24.0	21.0	18.2	14.6	12.1	10.4	9.1	8.1	7.3	1.7	1.1	0.84	0.67		
1/2" MNPT	XT080 RED	30	6.9	50.0	40.0	33.0	29.0	25.0	20.0	16.7	14.4	12.6	11.2	10.0	2.3	1.5	1.2	0.92	17	
		40	8.0	58.0	47.0	39.0	33.0	29.0	23.0	19.4	16.6	14.6	12.9	11.6	2.7	1.8	1.3	1.1		
		50	8.9	65.0	52.0	43.0	37.0	32.0	26.0	22.0	18.5	16.2	14.4	13.0	3.0	2.0	1.5	1.2		
		60	9.8	71.0	57.0	48.0	41.0	36.0	29.0	24.0	20.0	17.8	15.9	14.3	3.3	2.2	1.6	1.3		
3/4" MNPT	XT167 WHITE	30	14.5	112.0	90.0	75.0	64.0	56.0	45.0	37.0	32.0	28.0	25.0	22.0	5.1	3.4	2.6	2.1	16	
		40	16.7	129.0	103.0	86.0	74.0	65.0	52.0	43.0	37.0	32.0	29.0	26.0	5.9	4.0	3.0	2.4		
		50	18.7	145.0	116.0	96.0	83.0	72.0	58.0	48.0	41.0	36.0	32.0	29.0	6.6	4.4	3.3	2.7		
		60	20.5	159.0	127.0	106.0	91.0	79.0	63.0	53.0	45.0	40.0	35.0	32.0	7.3	4.9	3.6	2.9		
3/4" MNPT	XT215 GRAY	30	18.6	115.0	92.0	77.0	66.0	58.0	46.0	38.0	33.0	29.0	26.0	23.0	5.3	3.5	2.6	2.1	20	
		40	21.5	133.0	106.0	89.0	76.0	67.0	53.0	44.0	38.0	33.0	30.0	27.0	6.1	4.1	3.1	2.4		
		50	24.0	149.0	119.0	99.0	85.0	74.0	59.0	50.0	42.0	37.0	33.0	30.0	6.8	4.5	3.4	2.7		
		60	26.3	163.0	130.0	108.0	93.0	81.0	65.0	54.0	46.0	41.0	36.0	33.0	7.5	5.0	3.7	3.0		

Note: Application rates are based on overall swath widths listed at 48" height. Refer to operating instructions if using a different swath.

RIGHT-OF-WAY APPLICATIONS				Gallons per Acre												GAL/1000 Sq. Ft.				Swath Width (Ft) @ 40 PSI
				MPH												MPH				
Thread	XT Model	PSI	GPM	4	5	6	7	8	10	12	14	16	18	20	2	3	4	5		
3/8" MNPT	XT043R BLUE	30	3.7	29.0	23.0	19.1	16.4	14.3	11.4	9.5	8.2	7.2	6.4	5.7	1.3	0.88	0.66	0.53	16	
		40	4.3	33.0	27.0	22.0	19.0	16.6	13.3	11.1	9.5	8.3	7.4	6.7	1.5	1.0	0.76	0.61		
		50	4.8	37.0	30.0	25.0	21.0	18.6	14.9	12.4	10.6	9.3	8.3	7.4	1.7	1.1	0.85	0.68		
		60	5.3	41.0	33.0	27.0	23.0	20.0	16.4	13.7	11.7	10.2	9.1	8.2	1.9	1.3	0.94	0.75		
1/2" MNPT	XT080R YELLOW	30	6.9	50.0	40.0	33.0	29.0	25.0	20.0	16.7	14.4	12.6	11.2	10.0	2.3	1.5	1.2	0.92	15	
		40	8.0	58.0	47.0	39.0	33.0	29.0	23.0	19.0	16.6	14.6	12.9	11.6	2.7	1.8	1.3	1.1		
		50	8.9	65.0	52.0	43.0	37.0	32.0	26.0	22.0	19.0	16.2	14.4	13.0	3.0	2.0	1.5	1.2		
		60	9.8	71.0	57.0	48.0	41.0	36.0	29.0	24.0	20.0	18.0	15.9	14.3	3.3	2.2	1.6	1.3		

Note: Application rates are based on overall swath widths listed at 48" height. Refer to operating instructions if using a different swath.

### Standard Pattern

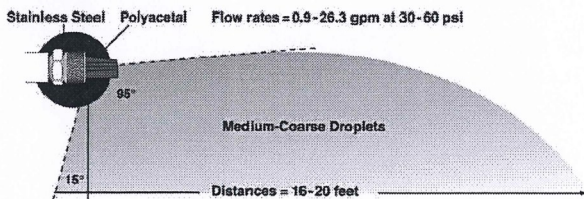

### Right-of-Way Pattern

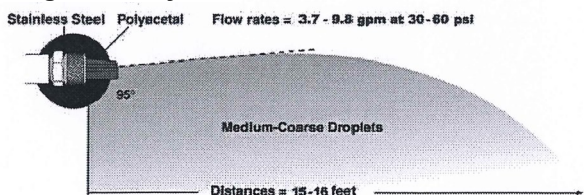

### Typical Spray Pattern Produced by XT Series

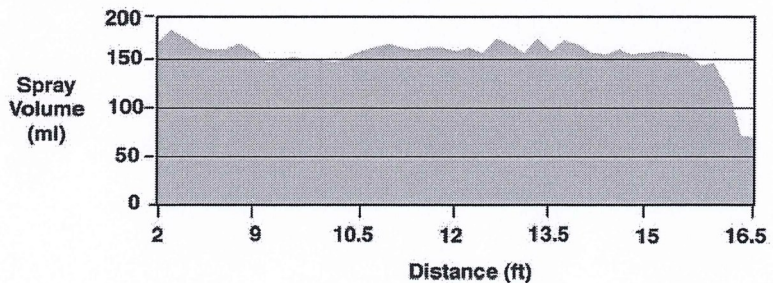

### Spraying Solutions Other Than Water

Since all the tabulations are based on spraying water, which weighs 8.34 lbs. per USA gallon, conversion factors must be used when spraying solutions which are heavier or lighter than water. To determine the proper size nozzle for the solution to be sprayed, first multiply the desired GPM or GPA of solution by the rate conversion factor. Then use the new converted GPM or GPA rate to select the proper size nozzle.

**Example:** Desired application rate is 20 GPA of 28% Nitrogen.

Determine the correct nozzle size as follows:

GPA (Solution) x Conversion Factor = GPA

20 GPA (28%) x 1.13 + 22.6 GPA (Water)

The applicator should choose a nozzle size that will supply 22.6 GPA of water at the desired pressure.

Weight of Solution	Specific Gravity	Conversion Factors
7.0 lbs. per gallon	.84	.92
8.0 lbs. per gallon	.96	.98
8.345 lbs. per gallon (Water)	1.00	1.00
9.0 lbs. per gallon	1.08	1.04
10.0 lbs. per gallon	1.20	1.10
10.66 lbs. per gallon (28% Nitrogen)	1.28	1.13
11.0 lbs. per gallon	1.32	1.15
12.0 lbs. per gallon	1.44	1.20
14.0 lbs. per gallon	1.68	1.30

### Miscellaneous Conversion Factors

One Acre = 43,560 square feet = 0.405 Hectare

One Hectare = 2.471 Acres

One Gallon Per Acre = 9.35 Liters Per Hectare

One Mile = 5,280 Feet = 1,610 Meters = 1.61 Kilometers

One Gallon = 128 Fluid Ounces = 8 Pints = 4 Quarts = 3.79 Liters = 0.83 Imperial Gallons

One Pound Per Square Inch = 0.069 bar. = 6.895 Kilopascals

One Mile Per Hour = 1.609 Kilometers Per Hour

Higher pressure not only increases flow rate of the nozzle, but it also influences the droplet size and rate of orifice wear. As pressure is increased, the droplet size decreases and the rate of orifice wear is increased. The values given in the tabulation section of the manual indicates the most commonly used pressure ranges for the associated spray tips.

### Tank Care & Maintenance

**Warning:** Do not use the tank as a container for fuel oils, kerosene, gasoline or any other petroleum distillate product. All polyolefins are softened and permeated by such products. In an enclosed area the vaporization of these materials from the outside surface of the tank could create a dangerous condition.

The tank should not be used as a pressure vessel nor used with chemicals or solutions having a weight of more than 12 pounds per gallon.

Store the tank in a dry dark place when not in use. Storage out of sunlight will prolong the life of the tank.

Do not drop, strike or kick the tank, especially at low temperatures. Tanks become brittle and are subject to cracking at temperatures below 20° Fahrenheit.

Always flush the tank with water and a neutralizing agent at the end of each use, to prevent contamination of solutions.

### Maintenance During/After Spraying

Periodically close the suction line valve and check the strainer and clean the screen.

Always flush the entire plumbing system with water or a neutralizing agent after completing the spraying operation. Read the chemical label for disposal instructions.

Proper care and maintenance will prolong the life of your sprayer.

After use, fill the sprayer tank part way with water. Start the sprayer and allow the clear water to be pumped through the plumbing system and out through the spray nozzles. Refill the tank about half full with plain water and use FIMCO Tank Neutralizer and Cleaner and repeat cleaning instructions above (If no tank cleaner is available, you may substitute dish soap for this step, about 1-2 oz. per gallon). But a neutralizer/cleaner should be used to thoroughly clean the system. Flush the entire sprayer with the neutralizing/cleaning agent, then flush out one more time with plain water.

Follow the chemical manufacturer's disposal instructions of all wash or rinsing water. For the boom (if applicable) remove the tips and screens from the nozzle assemblies. Wash these items out thoroughly. Blow the orifice clean and dry. If the orifice remains clogged, clean it with a fine bristle (NOT WIRE) brush or with a toothpick. Do not damage the orifice. Water rinse and dry the tips before storing.

Flush the pump after each use. One of the common causes of faulty pump performance is "gumming" or corrosion inside the pump. This prevents the rollers from moving freely. Flush the pump with a solution that will neutralize liquid pumped. A rust inhibitor can also be squirted into the ports of the pump. Turn shaft several times to draw protective liquid through pump and coat entire inner surface.

**WARNING:** Never pump corrosive or abrasive liquids as these will cause rapid wear or deterioration of body, rotor, shaft and seals in the pump. Never run pump dry. Some chemicals will damage the pump valves if allowed to soak untreated for a length of time! ALWAYS flush the pump as instructed after each use. DO NOT allow chemicals to sit in the pump for extended times of idleness. Failure to follow this warning will void the product warranty.

**Follow the chemical manufacturer's instructions on disposal of all waste water from the sprayer.**

### Winter Storage

Drain all water out of your sprayer, paying special attention to the pump, handgun and valve(s). These items are especially prone to damage from chemicals and freezing weather.

The sprayer should be winterized before storage by pumping a solution of automotive antifreeze (containing a rust inhibitor) through the entire plumbing system. This antifreeze solution should remain in the plumbing system during the winter months. When spring time comes and you are preparing your sprayer for the spray season, rinse the entire plumbing system out, clearing the lines of the antifreeze solution. Proper care and maintenance will prolong the life of your sprayer.

Troubleshooting		
Symptom	Probable Cause(s)	Corrective Action
Pump Does Not Prime	Leak in suction line	Check hose and fittings for leaks and correct
	Obstruction in suction line	Inspect hose for debris or loose inner liner in hose
	Suction strainer clogged	Clean strainer
	Suction hose sucked to bottom or side of tank	Cut a notch or "V" in end of suction hose
	Air lock in pump	Run pump with discharge hose removed to clear air lock
	Pump worn	Replace or repair pump
	Rollers stuck in pump	Disassemble pump and inspect rollers
	Pump seals worn, leaking air	Replace seals
Loss of Pressure	Clogged suction strainer	Check strainer and clean it regularly
	Kinked or blocked suction hose	Inspect suction hose and repair as necessary
	Air leak in inlet side plumbing	Check hose and connections for leaks Use pipe joint sealant and retighten connections
	Relief valve setting too low or weakened spring	Check relief valve and correct setting
	Faulty Gauge	Replace gauge
	Pump seals leak air	Replace seals
	Nozzle orifices worn	Replace nozzles
	Pump worn	Repair pump
Erratic Pressure Gauge Fluctuates Excessively	Suction line has air leak	Tighten all fittings and hoses between pump and tank
	Debris in valve or gauge	Remove and clean parts
	Kinked or blocked suction hose	Remove suction line and clean-check tank and strainer
	Air leak in suction hose	Tighten all fittings - replace hose if necessary
	Suction hose collapsed	Replace hose
	Pump is sucking air or air has not been evacuated from strainer	Make sure suction hose is tightly secured. Run pump with discharge hose removed to remove air lock from pump
Pump will not turn	Corrosion (rust), scale or residue	Loosen endplate bolts. Squirt oil into ports to help free rotor. Retighten bolts.
	Solid object lodged in pump.	Disassemble pump and remove objects
Pump Leaks	Worn out seal	Replace seal
Excessive Vibration or Noisy Pump	Loose coupler or damaged shaft	Inspect shaft and tighten coupler
	Excessive PTO or engine speed	Reduce PTO or engine speed
	Rotor or internal problem	Replace rotor or pump
	Partially clogged strainer	Clean strainer
	Air leak in suction hose	Inspect suction hose - replace if necessary
Pump Runs, but Low Pressure	Debris in suction line	Clear debris
	Hose kinked	Straighten or replace hose if necessary
	Worn rollers	Replace rollers
	Strainer clogged	Clean strainer
Pump Pressure Good, but Low Output Through Nozzles	Nozzle size may be too small or clogged	Clean nozzles - replace nozzles if necessary
	Inlet line too small or blocked	Clear blockage and if necessary replace hose
	By-pass open too much	Close slightly

# Exploded View: 3PT-300-8R-2BB (5303772)

Refer to the parts list next page for part numbers.

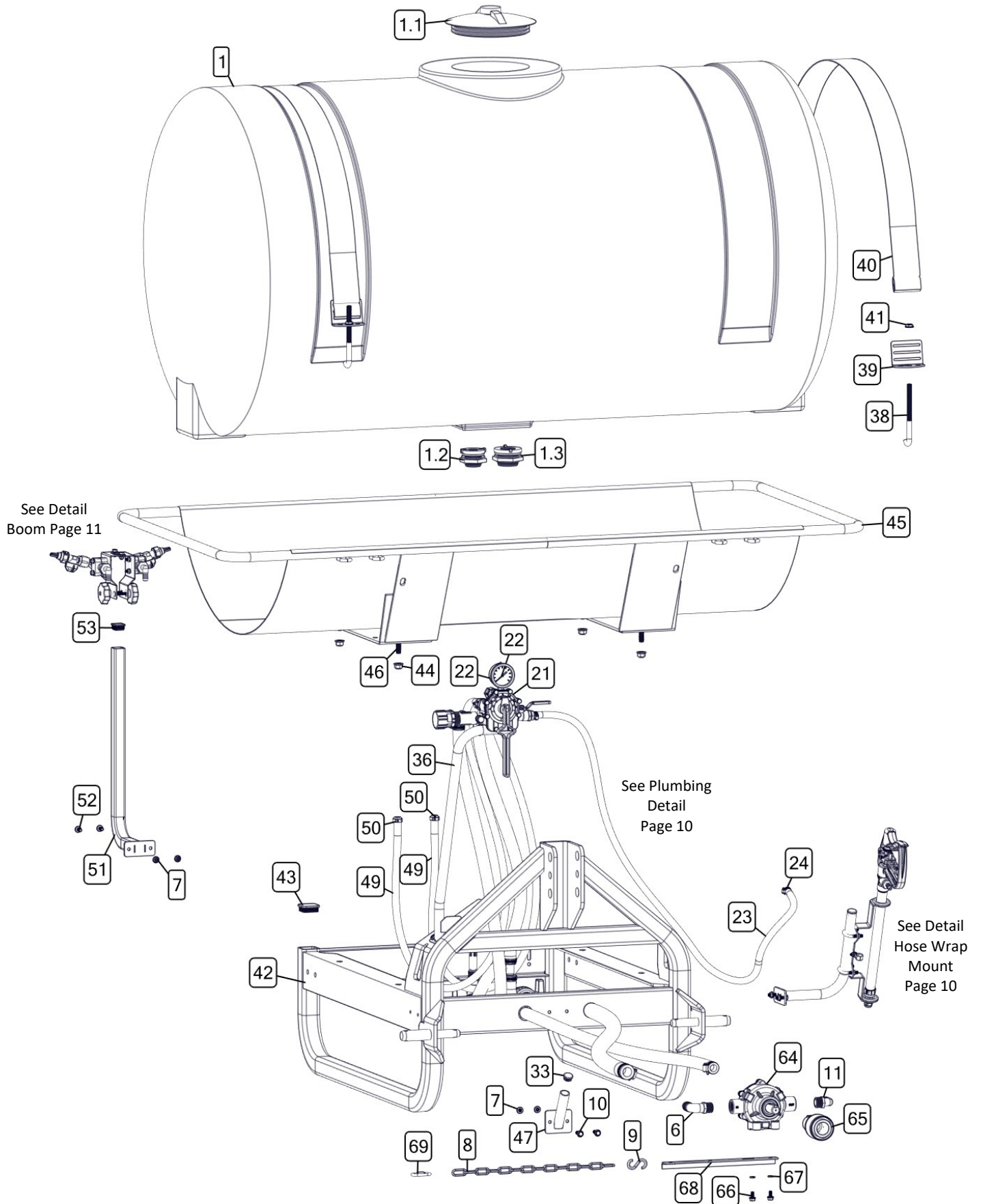

## Parts List: 3PT-300-8R-2BB (5303772)

Ref. #	Part #	Description	Qty
1	5169002	300 Gallon Tank (38" x 73" x 62 1/2")	1
1.1	63480	8" Lid w/Blue Snap-In Vent	1
1.2	5273736	3/4" Double-Threaded Bulkhead Fitting	1
1.3	5274362	1-1/4" Double-Threaded Bulkhead Fitting	1
2	5041082	Reducer Bushing, 1 1/4" MNPT x 1" FNPT	1
3	5282950	200/300G 3PT Tank Drain w/Strainer	1
3.1	5010245	Poly Street Elbow, 1"MNPT x 1" FNPT	1
3.2	5011141	Poly Close Nipple, 1" MNPT	3
3.3	5143207	1" Single Union Ball Valve	1
3.4	5010232	Poly Tee, 1" FNPT	1
3.5	5067119	Poly Fitting, 1" MNPT x 0.75" HB	1
3.6	5116441	1" Nylon Strainer (Black, 40 Mesh)	1
3.6.1	5072229	EPDM Gasket	1
3.6.2	5116180	Screen (40 Mesh)	1
3.6.3	5058075	Strainer Bowl	1
3.7	5067118	Poly Fitting, 1" MNPT x 1" HB	1
4	5020314	Hose, 1"-2 Brd. x 60"	1
5	5051025	Hose Clamp (1")	2
6	5010210	Poly Elbow, 3/4" MNPT x 1" HB	1
7	5006307	5/16-18 Serrated Fling Hex Nut	12
8	5049017	Torque Chain, 24"	1
9	5082006	"S" Hook	1
10	5117300	5/16-18 x 1.00 Fling Hex Bolt	6
11	5010209	Poly Elbow, 3/4" MNPT x 3/4" HB	1
12	5020211	Hose, 3/4"-2 Brd. x 60"	1
13	5051024	Hose Clamp (3/4")	8
14	5086030	Poly Hose Tee, 3/4" HB	1
15	5020472	Hose, 3/4"-2 Brd. x 17"	1
16	5067127	Poly Fitting, 3/4" MNPT x 3/4" HB	1
17	5143206	3/4" Single Union Ball Valve	1
18	5010244	Poly Street Elbow, 3/4" FNPT x 3/4" MNPT	1
19	5014011	Delta Jet Agitator	1
20	5020469	Hose, 3/4"-2 Brd. x 32"	1
21	5282943	3PT Manifold Assembly	1
21.1	5067127	Poly Fitting, 3/4" MNPT x 3/4" HB	1
21.2	5067125	Poly Fitting, 3/4" MNPT x 1/2" HB	2
21.3	5143295	TeeValve Assembly (AA-17L)	1
21.4	5011147	Reducing Nipple, 3/4" MNPT x 1/2" MNPT	1
21.5	5143197	1/2" T-800 Brass Ball Valve	1
21.6	5067130	Poly Fitting, 1/2" MNPT x 3/8" HB	1
21.7	5143199	Pressure Relief Valve, 3/4"	1
21.8	5010209	Poly Elbow, 3/4" MNPT x 3/4" HB	1
22	5167034	Gauge, Liquid-Filled, 0-400# p.s.i.	1
23	5020099	Hose, 3/8"-2 Brd. x 25 Ft.	1
24	5051144	Hose Clamp (3/8")	2
25	5117167	#10-24 x 0.625 Phillips Truss Head Screw	1
26	5051122	5/8" Black Nylon Loom Cable Clamp	1
27	5006186	#10-24 Serrated Fling Hex Nut	1
28	5163150	22" HP Spray Gun with 3/8" Hose Barb	1
28.1	5163136	High Pressure Aluminum Spray Gun 22"	1
28.2	5067130	Poly Fitting, 1/2" MNPT x 3/8" HB	1
29	5034063	5/16-18 x 1.1875 x 1.75 Round U-Bolt	2
30	5282940-BLK	Hose Wrap Mount	1

Ref. #	Part #	Description	Qty
31	5070361-BLK	Handgun & Hose Bracket	1
32	5075014	Rubber Grommet (Black)	2
33	5046441	1" Diameter Cap Plug	2
34	5020979	Hose, 3/4"-2 Brd. x 42"	1
35	5006259	3/8-16 Serrated Fling Hex Nut	2
36	5282949-BLK	Manifold Bracket 200/300G	1
37	5117307	3/8-16 x 1.00 Fling Hex Bolt	2
38	5034111	1/2-13 x 6.00 Hook Bolt	4
39	5108112-BLK	Tank Strap Buckle (Bent, for 3" Strap)	4
40	5133274	Poly Tank Strap, 3" x 84"	2
41	5006337	1/2-13 Serrated Fling Hex Nut	4
42	5282948-RED	300 3PT Tube Frame	1
43	5046445	2" Square Tube Cap	2
44	5006399	1/2-13 Fling Top-Lock Hex Nut	4
45	5273831-BLK	38"-300 Saddle Weldment	1
46	5034691	1/2-13 x 1.25 Fling Hex Bolt	4
47	5282938-BLK	Pump Mount	1
48	5102071	Poly Pipe Plug, 3/4" MNPT	1
49	5020124	Hose, 1/2"-1 Brd. x 8 Ft.	2
50	5051114	Hose Clamp (1/2")	4
51	5282934-BLK	Boom Mount Upright	1
52	5117323	5/16-18 x 0.75 Fling Hex Bolt	2
53	5046448	1-1/4" Square Tube Cap	1
54	5034807	1/4-20 x 1.75 Carriage Bolt	2
55	5088026	5 Lobe Knob 1/4-20UNC	2
56	5034609	1/4-20 x 0.50 Fling Hex Bolt	2
57	5095983-BLK	Boomless Nozzle Mount	2
58	5006344	1/4-20 Fling Top-Lock Hex Nut	2
59	5034615	1/4-20 x 2.00 Fling Hex Bolt (Full Thread)	4
60	5051174	2-Piece Wet Boom Clamp	2
61	5006344	1/4-20 Fling Top-Lock Hex Nut	4
62	5282932	Boomless Nozzle (LH) FC-XT020 Tip	1
62.1	5149158	Poly Elbow, 1/2" FNPT x 1/2" Hose Barb	1
62.2	5011258	1/2" Pipe Nipple, 4" Long, 304 SS	1
62.3	5010236	Poly Elbow, 1/2" FNPT x 1/2" FNPT	1
62.4	5041073	Reducing Bushing, 1/2" MNPT x 1/4" FNPT	1
62.5	5002380	QJ Diaphragm Check Valve 1/4 MNPT	1
62.6	5018349	Extended Range Tip	1
63	5282931	Boomless Nozzle (RH) FC-XT020 Tip	1
63.1	5149158	Poly Elbow, 1/2" FNPT x 1/2" Hose Barb	1
63.2	5011258	1/2" Pipe Nipple, 4" Long, 304 SS	1
63.3	5010236	Poly Elbow, 1/2" FNPT x 1/2" FNPT	1
63.4	5041073	Reducing Bushing, 1/2" MNPT x 1/4" FNPT	1
63.5	5002380	QJ Diaphragm Check Valve 1/4 MNPT	1
63.6	5018349	Extended Range Tip	1
64	5271077	8-Roller Cast Iron Pump	1
65	5057146	Quick Coupler (15/16")	1
66	5034634	5/16-18 x 0.625 Fling Hex Bolt	2
67	5016026	5/16 Lock Washer	2
68	5038513-BLK	Torque Bracket	1
69	5094039	1/4" Rapid/Quick Link	1

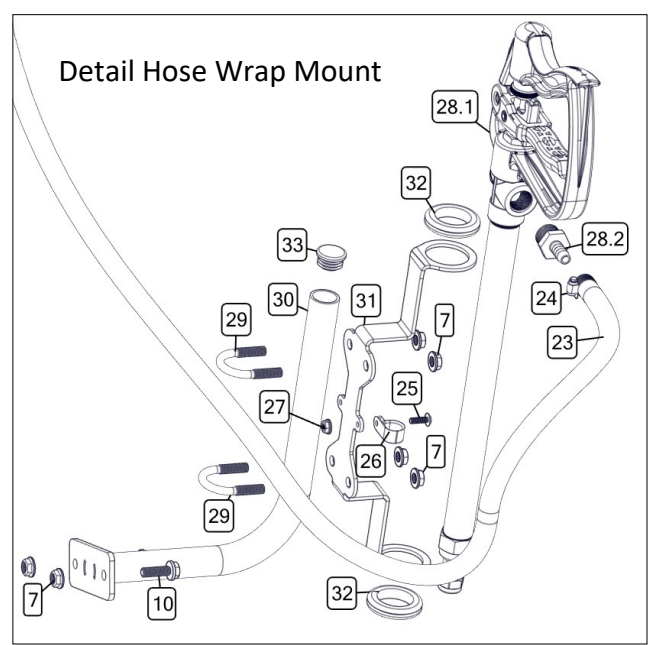
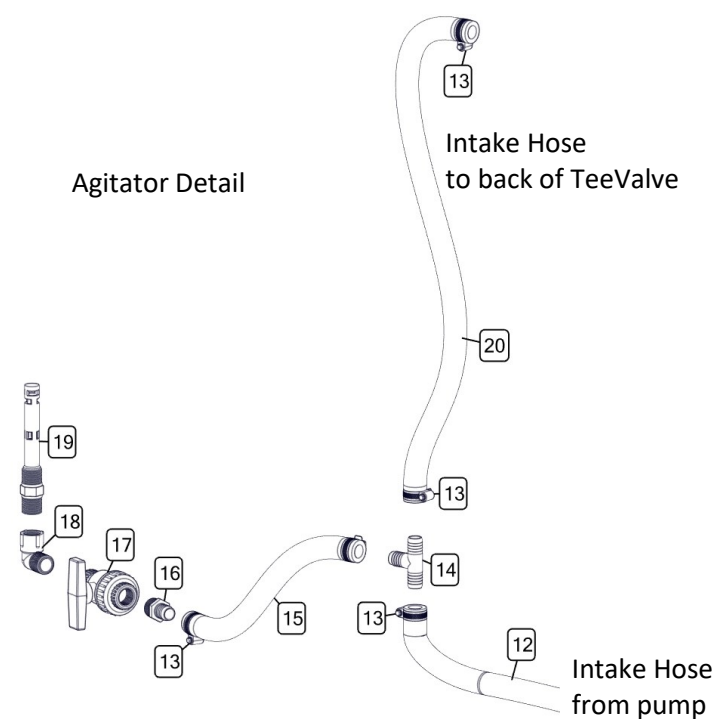
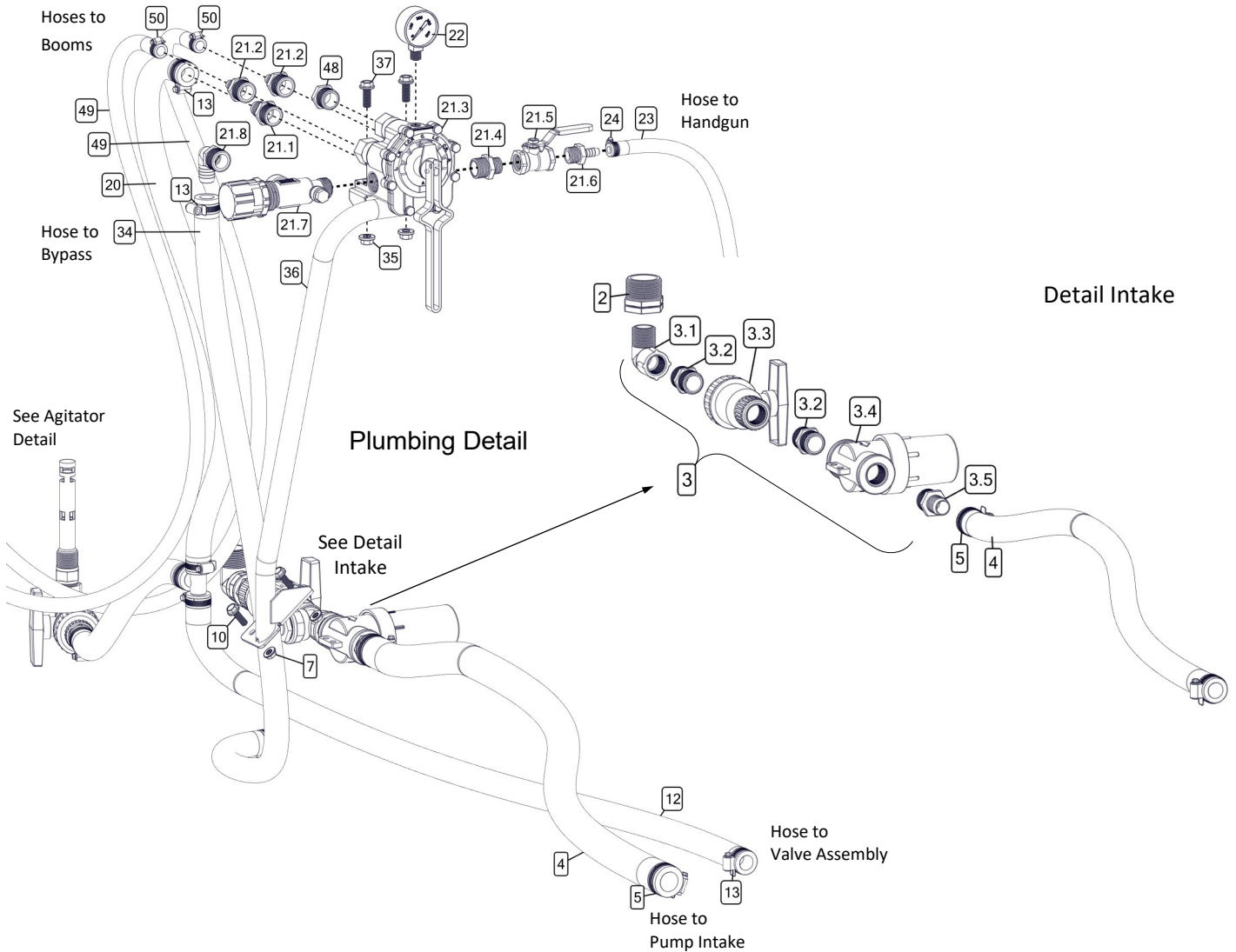

# Detail Boom

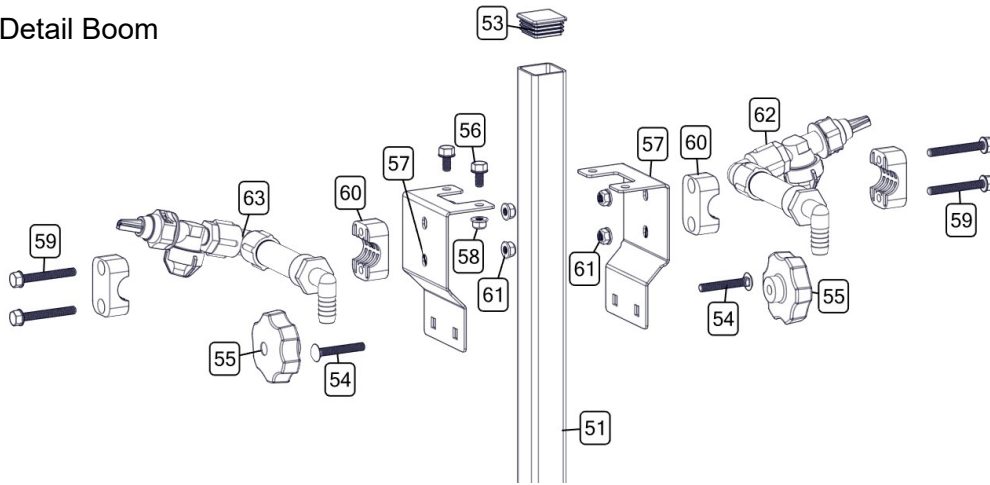

# Broadcast Nozzle Assemblies

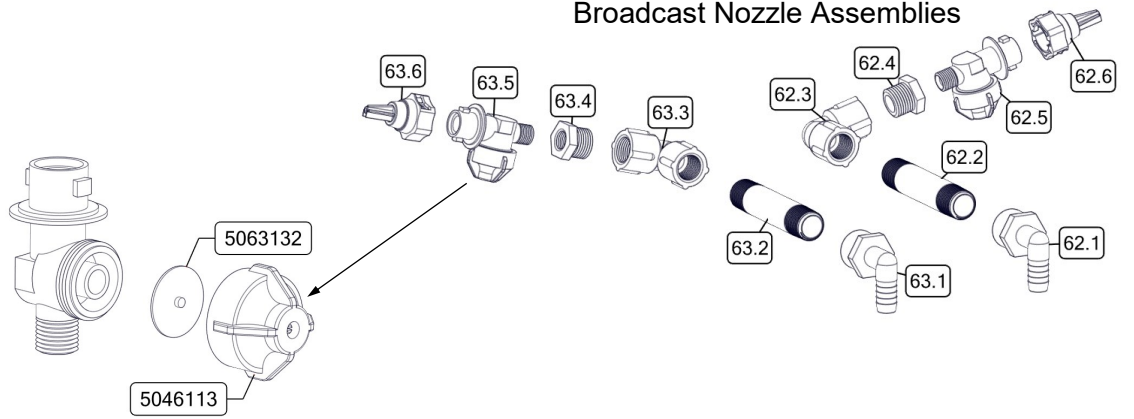

## Piston Type Pressure Relief/Regulating Valves

Bypasses excess fluid. Adjustable to maintain control of line pressure at any pressure within the valve operating range.

Selected pressure setting firmly held in place by locknut. Extra large passages to handle large flows.

- Polypropylene with stainless steel spring
- Excellent chemical resistance
- EPDM O-Rings
- Fore pressure to 150 p.s.i.
- 1/4" port for pressure gauge
- 3/4" NPT (M) inlet & (F) outlet connections

Ref. #	Part #	Mfg. Part #	Description
1	5046270	CP23122-NY	Adjusting Cap, Nylon (Gray)
2	5110266	CP23123-PP	Lock Ring
3	◆◆	CP23124-PP	Spring Retainer
4	**	CP7717-15-EPR	O-Ring, EPDM Rubber
5	**	CP23127-302SS	Spring
6	◆◆	CP23125-PP	Guide Seat
7	**	CP23126-302SS	Retaining Pin
8	CP23121-PP	CP23121-PP	Poly Body (3/4" NPT)
9	5102022	F14	Pipe Plug, 1/4" MNPT

\*\* Available ONLY in Repair Kit

◆◆ ONLY Available in Complete Assembly

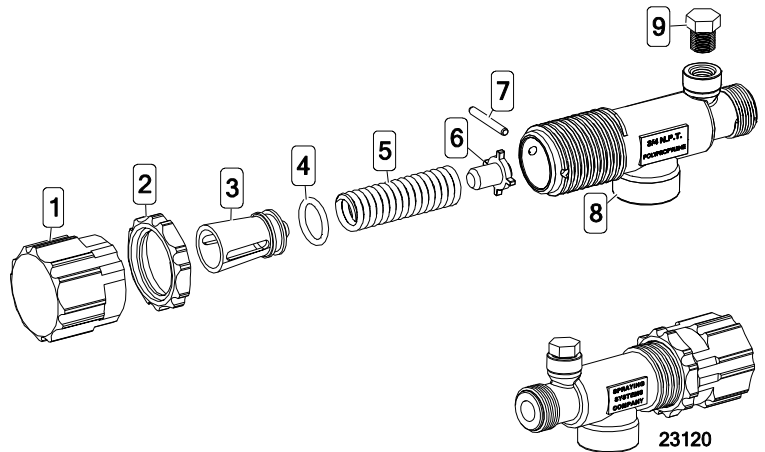

Ref. #	Part #	Mfg. Part #	Description
1	5143199	23120-3/4-PP	Pressure Relief Valve, (3/4" NPT)
2	5168717	PK-AB23120-KIT	Repair Kit, Items Marked **

## TeeValve Control Valve Model: AA17L (5143295)

Model AA17L, used for selective control of 3-section boom sprayers  
at pressures up to 300 PSI.

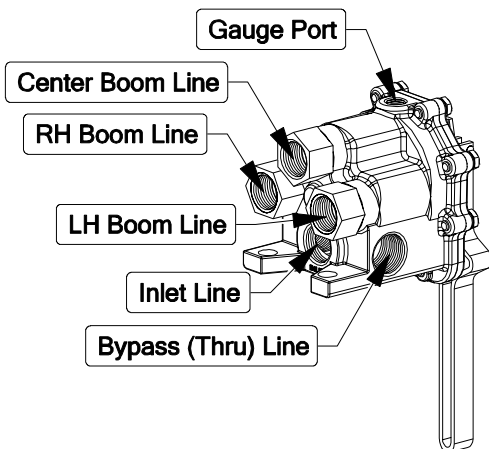

- Use to open any of three boom sections lines in any desired combination.
- Raise lever to open, lower lever to close the valve without changing the indexed position.
- Aluminum construction with stainless steel and plastic internal parts for maximum corrosion resistance.
- 3/4" NPT Inlet/Outlet, 3 boom outlet and accessory outlet.
- 1/4" NPT Gauge Port

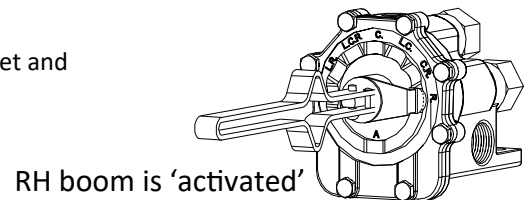
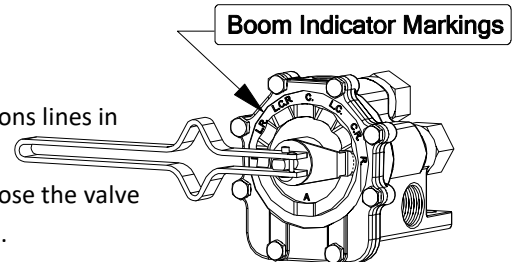

# PRO SERIES Long Range Ergonomic Handguns

## Technical Specifications:

- Adjustable Spray Pattern
- No Drip Shut Off
- Aluminum Barrel
- Convenient Hanger Hole
- 600 PSI, 8 GPM
- Chemical Resistant Construction
- 38' Horizontal, 27' Vertical Maximum Spray Distance
- Integrated Trigger Lock
- Adjustable On/Off Trigger Stop for Precise Spray Pattern

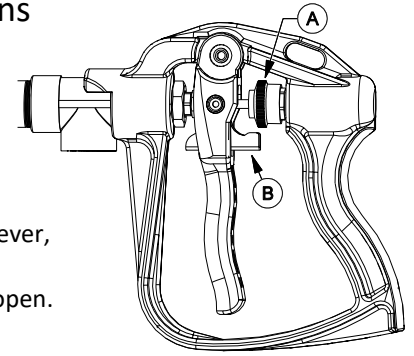

To adjust the spray pattern, the nut needs to be adjusted (Ref. A). Spinning it off, towards the lever, will make a cone pattern and spinning it on, away from the lever, will make a stream. The lever (Ref. B), is the lock that can be used to lock the lever when pulled, holding the valve open. Squeezing the trigger, will release the lock.

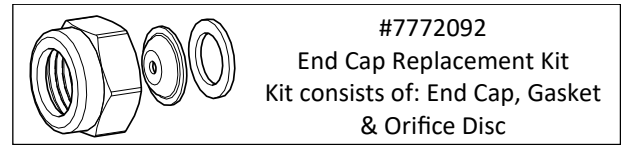
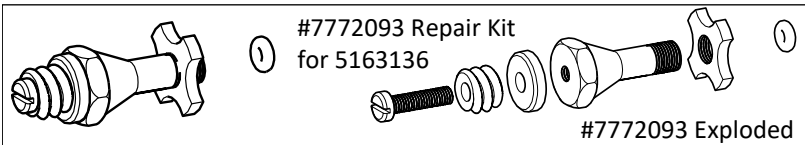

### Torque Chain Attachment to a Roller Pump

Torque bracket, torque, torque chain, 'S' hook, washers, bolts and rapid/quick link are included to secure your pump during operation.

1. Attach torque bracket to bottom of roller pump using the two lock washers and hex bolts.
2. Hook the 'S' Hook on to the end of the torque bracket.
3. Hook the chain on to the other end of the 'S' Hook and wrap the chain around the frame or hitch and use the rapid/quick link to secure it in place. Make sure connection is very secure! If not secured, it may result in the pump spinning on PTO shaft and damaging some components of your sprayer.

\*\*\* Insure that this connection point will not allow the roller pump to spin on the PTO shaft \*\*\*

### Strap/Buckle Detail

#### Strap Attachment to a "Bent" Buckle

The nylon straps are to be inserted in and out of the slots in the buckle, as shown. Be sure the straps are snug before tightening the hook bolts. In most cases, it will be necessary to re-tighten the straps after filling the tank with liquid.

## Cast Iron 8-Roller Pump Assembly #5271077 (Hypro Mfg. Part # 7560C)

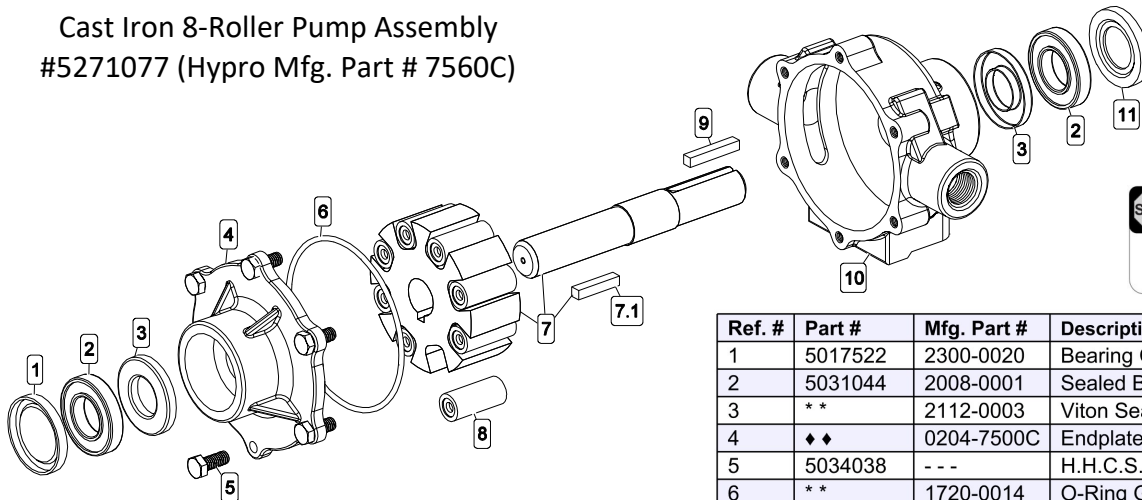

**STOP WARNING STOP**  
DO NOT USE PUMP IN AN EXPLOSIVE ENVIRONMENT. DO NOT USE TO PUMP FLAMMABLE/COMBUSTIBLE FLUIDS, GASOLINE, KEROSENE, FUEL, OIL, ETC.

\* \* = Available ONLY in Repair Parts Kit #7771794 (3430-0381) Consists of Rollers, O-Ring & Viton Seals

◆ ◆ Available ONLY in Complete Assembly

Ref. #	Part #	Mfg. Part #	Description	Qty
1	5017522	2300-0020	Bearing Cover	1
2	5031044	2008-0001	Sealed Ball Bearing	2
3	* *	2112-0003	Viton Seal (Standard)	2
4	◆ ◆	0204-7500C	Endplate (Cast Iron) w/Seal	1
5	5034038	- - -	H.H.C.S. 5/16"-18nc x 3/4"	6
6	* *	1720-0014	O-Ring Gasket for Endplate	1
7	5172113	0308-7560C	Rotor w/Shaft Assembly	1
7.1	1610-0059	1610-0059	Key (Stainless Steel)	1
8	5112030	1005-0004	Super Roller (Standard)	8
9	5089012	1610-0005	Key	1
10	◆ ◆	0104-7500C	Body (Cast Iron) w/Seal	1
11	5017523	2300-0022	Shaft Bearing Cover	1

## Roller Pump General Safety Information

1. Use a pressure relief device on the discharge side of the pump to prevent damage from pressure buildup when the pump discharge is blocked or otherwise closed and the power source is still running.
2. **WARNING:** Never pump flammable or explosive fluids such as gasoline, fuel oil, kerosene, etc. Never use in explosive atmospheres. The pump should be used only with liquids compatible with the pump component materials. Failure to follow this warning can result in personal injury and/or property damage and will void the product warranty.
3. Never pump acids (i.e. acid fertilizer) with Super Rollers!
4. Never run the pump faster than maximum recommended speed.
5. Never pump at pressures higher than the maximum recommended pressure.
6. Never pump liquids at temperatures higher than the recommended maximum temperatures (140°F/60°C).
7. Make certain that the power source conforms to the requirements of your equipment.
8. Provide adequate protection in guarding around the moving parts such as the shaft and pulleys.
9. Disconnect power before servicing.
10. Release all pressure within the system before servicing any component.
11. Drain all liquids from the system before servicing any component.
12. Check all hoses for weak or worn condition before each use. Make certain that all connections are tight and secure.
13. Periodically inspect the pump and the system components. Perform routine maintenance as required.
14. Never operate a gasoline engine in an enclosed area. Be sure the area is well ventilated.
15. Use only pipe, hose and fittings rated for the maximum psi rating of the pump.
16. Never use pump for pumping water or other liquids for human or animal consumption.

## Roller Pump Operation & Maintenance

**WARNING:** Never pump corrosive or abrasive liquids as these will cause rapid wear or deterioration of the body, rotor, shaft and seals in the pump. The pump should be used on with liquids compatible with pump component materials. Never exceed maximum specified rpm and pressure. Never run pump dry. Failure to follow this warning will void the product warranty.

### Priming the Pump:

To help prime the pump, keep the inlet or suction line as short as possible with a minimum of bends, elbows and kinks. Make sure all connections are tight and do not leak air. Make sure line strainer is free of debris. If pump does not self-prime, disconnect suction hose, fill with water and reconnect to liquid source. Often a squirt of oil into the ports of the pump will seal clearance and help priming.

### Care of the Pump:

Proper care and maintenance will keep your pump wear at a minimum and will keep it running smoothly and trouble-free for a long time.

### Flush the Pump After Each Use

**One of the common causes of faulty pump performance is “gumming” or corrosion inside the pump. This prevents rollers from moving freely in their rotor slots. Flush the pump with a solution that will neutralize liquid pumped, mix according to manufacturer’s directions.**

### To Prevent Corrosion:

After cleaning pump as above, flush it with a 50-50 solution of permanent-type automotive antifreeze (containing a rust inhibitor) and water. A rust inhibitor can also be squirted into the ports of the pump. Turn shaft several times to draw protective liquid through pump and coat entire inner surface. Drain pump and plug ports to keep out air during storage. For short periods of idleness, noncorrosive liquids may be left in the pump, but air must be kept out. Plug ports or seal port connections.

## Troubleshooting

Symptom	Probable Cause(s)	Corrective Action
Pump Does Not Prime	Leak in suction line	Check hose and fittings for leaks and correct
	Obstruction in suction line	Inspect hose for debris or loose inner liner in hose
	Suction hose sucked to bottom or side of tank	Cut a notch or "V" in end of suction hose
	Rollers stuck in pump	Disassemble pump and inspect rollers
	Pump seals leaking air	Replace seals
Loss of Pressure	Clogged suction strainer	Check strainer and clean it regularly
	Kinked or blocked suction hose	Inspect suction hose and repair as necessary
	Air leak in inlet side plumbing	Check hose and connections for leaks Use pipe joint sealant and retighten connections
	Relief valve setting too low or weakened spring	Check relief valve and correct setting
	Faulty Gauge	Replace gauge
	Pump seals leak air	Replace seals
	Nozzle orifices worn	Replace nozzles
Pump worn	Repair pump	
Pump will not turn	Corrosion (rust), scale or residue	Loosen endplate bolts. Squirt oil into ports to help free rotor. Retighten bolts.
	Solid object lodged in pump.	Disassemble pump and remove objects

Approx. Dimensions

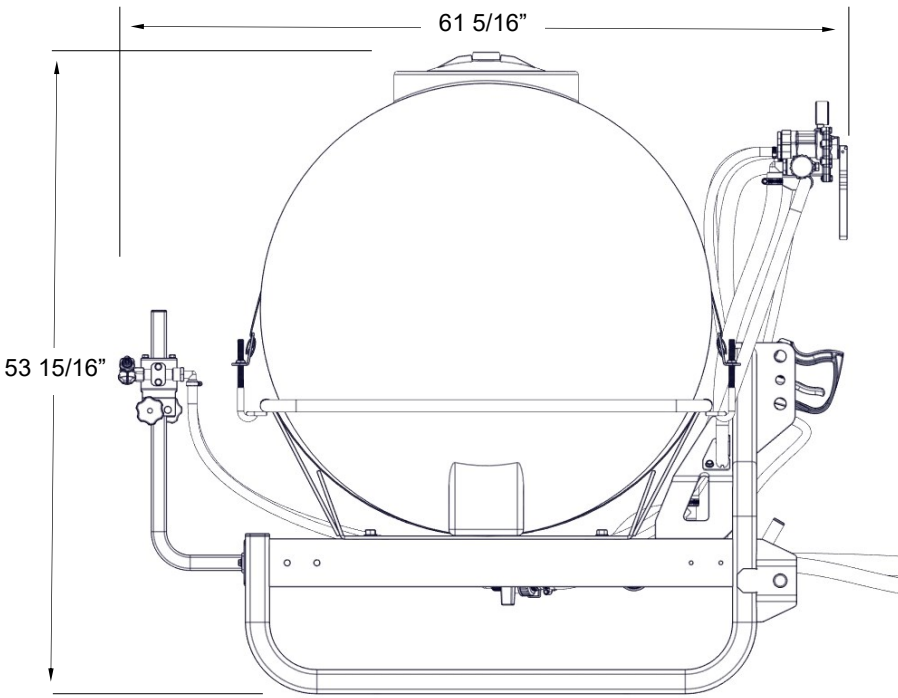
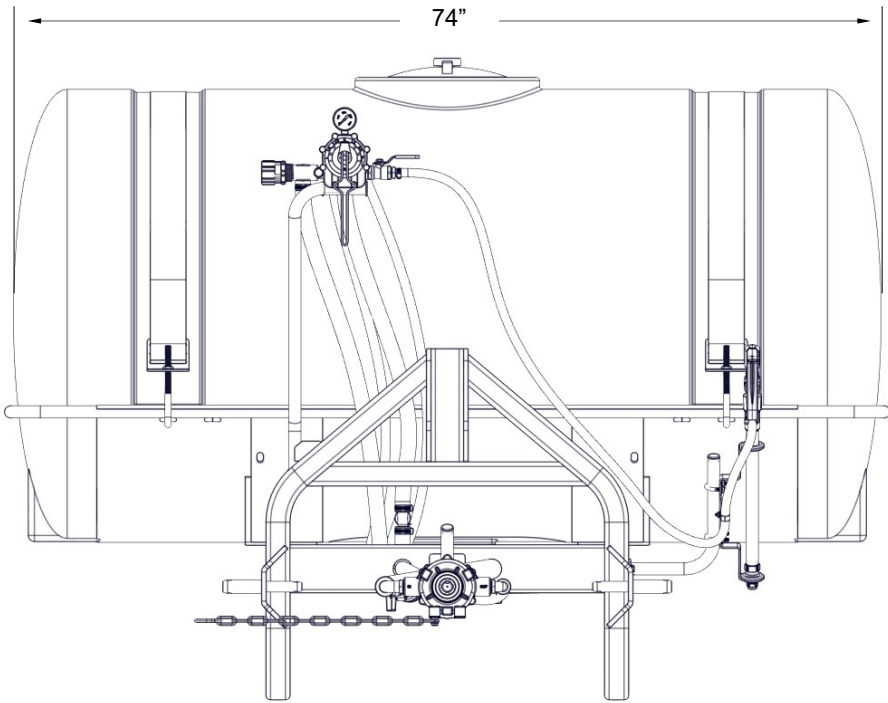

# Warranty

## LIMITED WARRANTY FOR NEW FIMCO, INC.

**WHO MAY USE THIS LIMITED WARRANTY.** This limited warranty (the "Limited Warranty") is provided by Fimco, Inc. to the original purchaser ("you") of the Equipment (as defined below) from Fimco, Inc. or one of Fimco, Inc.'s authorized dealers. This Limited Warranty does not apply to any subsequent owner or other transferee of the Equipment. THIS LIMITED WARRANTY GIVES YOU SPECIFIC LEGAL RIGHTS, AND YOU MAY ALSO HAVE OTHER RIGHTS WHICH VARY FROM STATE TO STATE.

**WHAT THIS LIMITED WARRANTY COVERS AND FOR HOW LONG.** Fimco, Inc. warrants that any new Equipment will be free from defects in material and workmanship for a period of **one (1) year** (homeowner), **90 days** (commercial user), after delivery of the Equipment to you (the "Warranty Period"). The Warranty Period is not extended if Fimco, Inc. repairs or replaces the Equipment.

**WHAT IS NOT COVERED BY THIS LIMITED WARRANTY.** This Limited Warranty does not apply to: (1) used Equipment; (2) any Equipment that has been altered, changed, repaired or treated since its delivery to you, other than by Fimco, Inc. or its authorized dealers; (3) damage or depreciation due to normal wear and tear; (4) defects or damage due to failure to follow Fimco, Inc.'s operator's manual, specifications or other written instructions, or improper storage, operation, maintenance, application or installation of parts; (5) defects or damage due to misuse, accident or neglect, "acts of God" or other events beyond Fimco, Inc.'s reasonable control; (6) accessories, attachments, tools or parts that were not manufactured by Fimco, Inc., whether or not sold or operated with the Equipment; or (7) rubber parts, such as tires, hoses and grommets.

**HOW TO OBTAIN WARRANTY SERVICE.** To obtain warranty service under this Limited Warranty, you must (1) provide written notice to Fimco, Inc. of the defect during the Warranty Period and within **thirty (30) days** after the defect becomes apparent or the repair becomes necessary, at the following address: Fimco, Inc., 1000 Fimco Lane, North Sioux City, SD 57049; and (2) make the Equipment available to Fimco, Inc. or an authorized dealer within a reasonable period of time. For more information about this Limited Warranty, please call: **800-831-0027**

**WHAT REMEDIES ARE AVAILABLE UNDER THIS LIMITED WARRANTY.** If the conditions set forth above are fulfilled and the Equipment or any part thereof is found to be defective, Fimco, Inc. shall, at its own cost, and at its option, either repair or replace the defective Equipment or part. Fimco, Inc. will pay for shipping and handling fees to return the repaired or replacement Equipment or part to you.

**LIMITATION OF IMPLIED WARRANTIES AND OTHER REMEDIES.** THE REMEDIES DESCRIBED ABOVE ARE YOUR SOLE AND EXCLUSIVE REMEDIES, AND FIMCO, INC.'S SOLE LIABILITY, FOR ANY BREACH OF THIS LIMITED WARRANTY. TO THE EXTENT APPLICABLE, ANY IMPLIED WARRANTIES, INCLUDING, WITHOUT LIMITATION, THE IMPLIED WARRANTIES OF MERCHANTABILITY AND FITNESS FOR A PARTICULAR PURPOSE, SHALL BE LIMITED IN DURATION TO THE WARRANTY PERIOD, AND THE REMEDIES AVAILABLE FOR BREACH THEREOF SHALL BE LIMITED TO THE REMEDIES AVAILABLE UNDER THIS EXPRESS LIMITED WARRANTY. SOME STATES DO NOT ALLOW LIMITATIONS ON HOW LONG AN IMPLIED WARRANTY LASTS, SO THE ABOVE LIMITATION MAY NOT APPLY TO YOU. IN NO EVENT SHALL FIMCO, INC.'S LIABILITY UNDER THIS LIMITED WARRANTY EXCEED THE ACTUAL AMOUNT PAID BY YOU FOR THE DEFECTIVE EQUIPMENT, NOR SHALL FIMCO, INC. BE LIABLE, UNDER ANY CIRCUMSTANCES, FOR ANY CONSEQUENTIAL, INCIDENTAL, SPECIAL OR PUNITIVE DAMAGES OR LOSSES, WHETHER DIRECT OR INDIRECT. SOME STATES DO NOT ALLOW THE EXCLUSION OR LIMITATION OF INCIDENTAL OR CONSEQUENTIAL DAMAGES, SO THE ABOVE LIMITATION OR EXCLUSION MAY NOT APPLY TO YOU.