

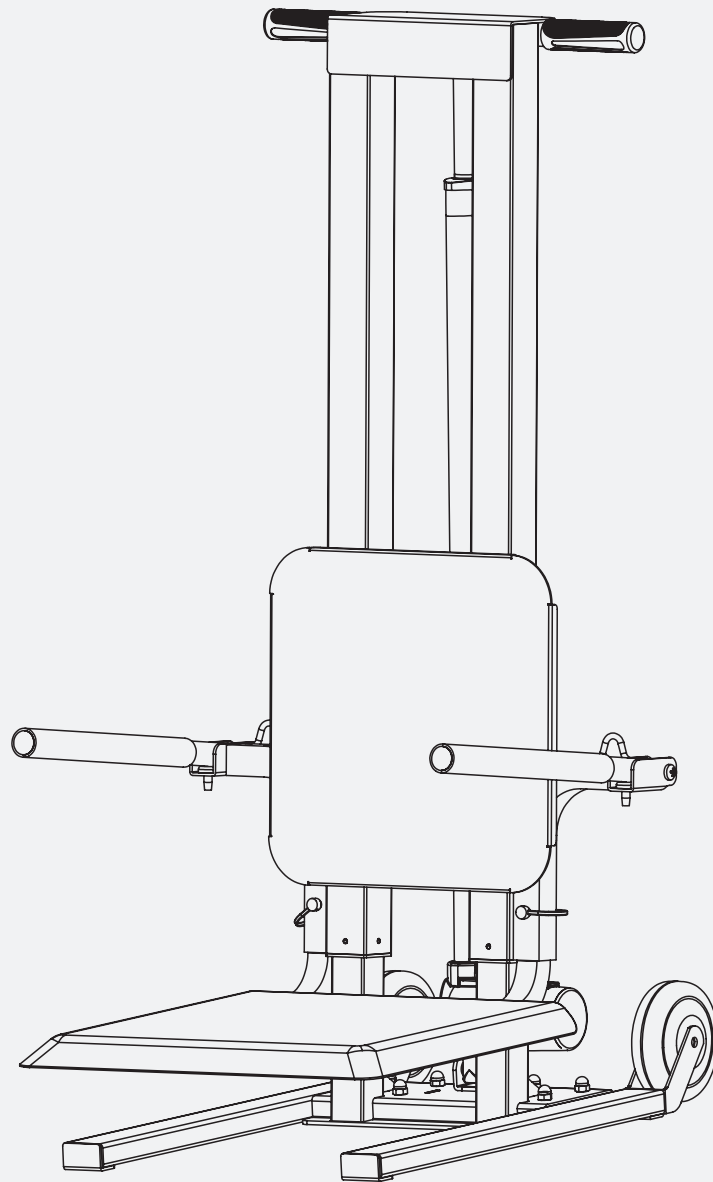

## 500 LBS Floor Lift | GUT168 Operator's Manual



**Warning:** Please read and thoroughly understand all instructions before operating. Failure to follow safety rules and other basic safety precautions may result in serious personal injury. Keep these instructions in a safe and easily accessible place so that they can be referred to when needed. Retain these instructions to assist in future servicing.

1. SAFETY INTRODUCTION -----	1
2. TECHNICAL DETAILS -----	1
3. KNOW YOUR MACHINE -----	2
4. CONTENTS SUPPLIED -----	3
5. ASSEMBLY -----	4-6
6. OPERATION -----	6-7
7. MAINTENANCE & STORAGE -----	7
8. WARRANTY -----	7

## 1. SAFETY INSTRUCTION

Prior to operating the floor lift, evaluate whether the user is appropriate for the device by considering aspects like weight, size, mental capacity, and joint movement. It's essential to ensure that individuals who are not suitable do not use the floor lift. Persons with disabilities should either have assistance nearby or be within reach of alarm devices during use.

### WARNING

1. DO NOT exceed the maximum weight capacity of the floor lift.
2. Please sit steadily on the floor lift and ensure the surrounding area is safe before use.
3. Do not use the floor lift on excessively sloped surfaces (more than 3 degrees) or on surfaces with steps.
4. Do not stand on the floor lift.
5. Do not use if any parts are missing.
6. Do not allow children to use this equipment.
7. Do not place the floor lift in overly hot areas, as it contains batteries.
8. When not in use for a long time, fully charge the battery before storing to prolong its life.

## 2. TECHNICAL SPECIFICATIONS

<b>SKU#</b>	<b>GUT168</b>
<b>Working Load Capacity</b>	500 lbs (227 kgs)
<b>Lifting Height (Above Ground)</b>	1.2-28.7 in. (30-730 mm)
<b>Lifting Speed</b>	0.4in/s (10mm/s)

<b>Linear Actuator</b>	
<b>Rated Voltage</b>	24V
<b>Stroke</b>	0-27.6 in. (0-700 mm)
<b>Duty Cycle</b>	2min on 18min off (max.10%)
<b>Max. Load</b>	3000N

<b>Battery</b>	
<b>Max. Output Voltage</b>	25.9V
<b>Max. Output Current</b>	5A
<b>Input Voltage</b>	24-30V
<b>Capacity</b>	2000mAh

<b>Power Adapter (Charger)</b>	
<b>Input</b>	100-240V, 50/60Hz, 1.5A
<b>Output</b>	29V, 2A

### 3. KNOW YOUR MACHINE

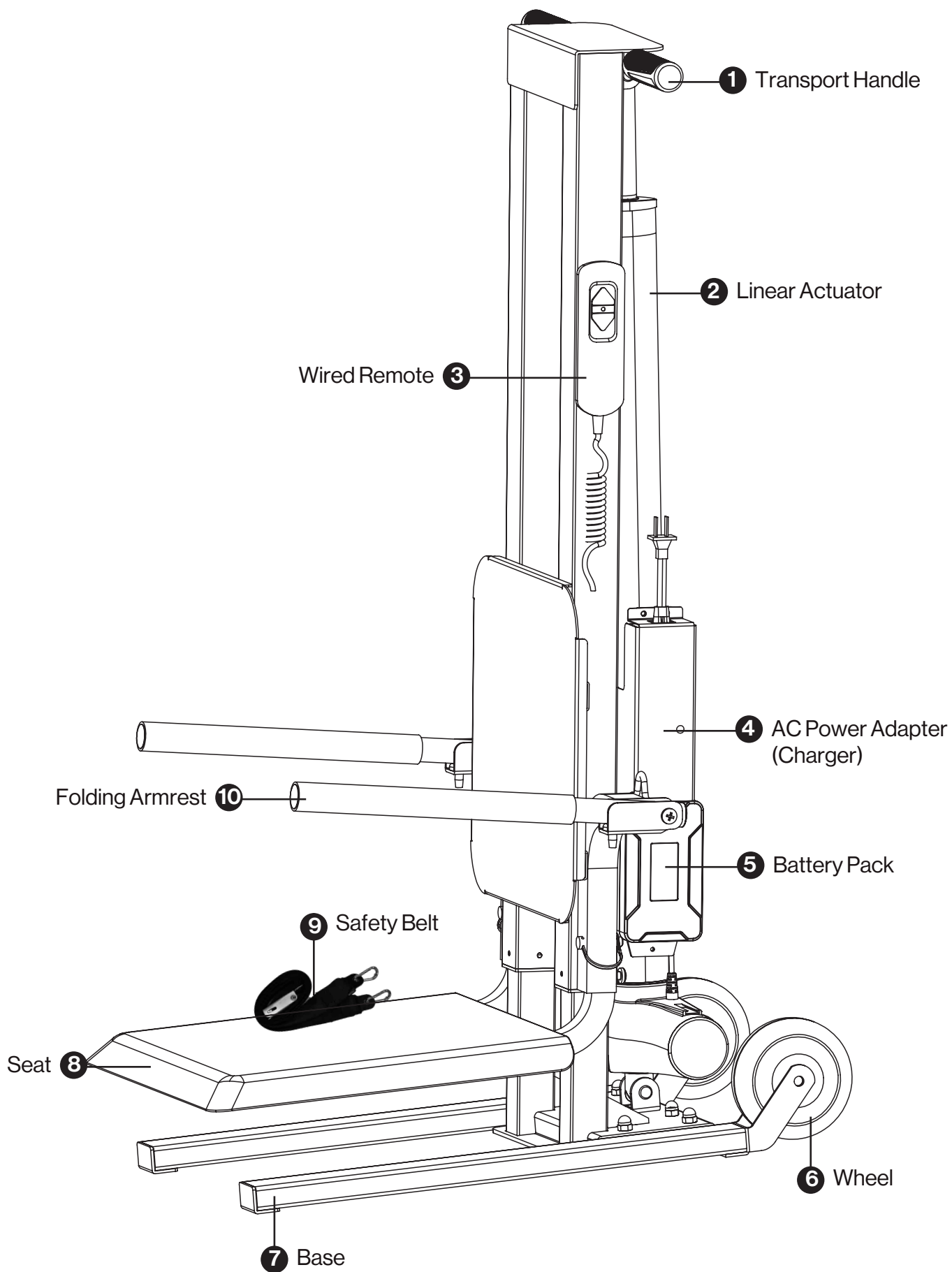

## 4. CONTENTS SUPPLIED

The floor lift comes partially assembled and is shipped in carefully packed carton. After all the parts have been removed from the carton, you should have:

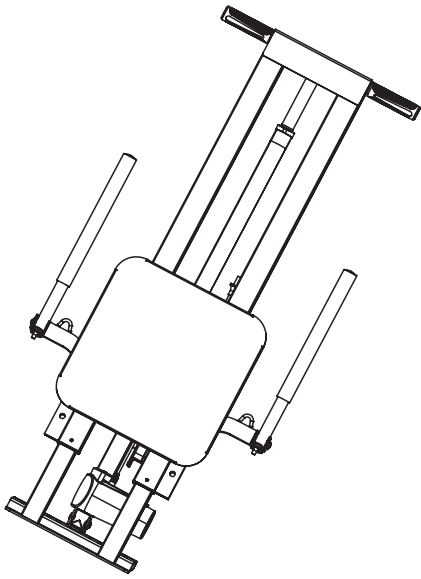

Main Body of the Lift

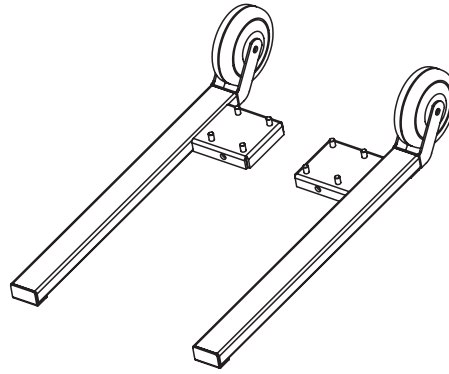

Left & Right Base

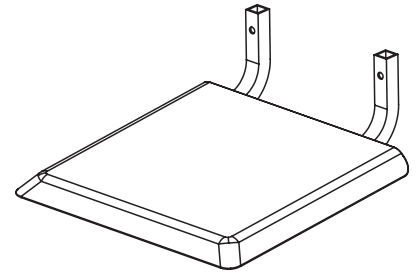

Seat



Safety Belt



Wired Remote

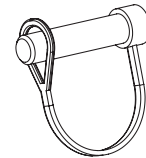

D-type Pin x2pcs



M8 Cap Nut x8pcs

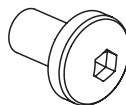

M8x14 Socket Button Cap Screw x 4pcs

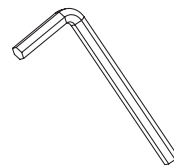

Allen Wrench

## 5. ASSEMBLY

### 5.1 Left & Right Base (See Fig. 01)

Align the mounting holes of the main body of the floor lift with the left and right bases, and use 8 M8 cap nuts to fasten the main body to the bases from top to bottom. Secure with M8x14 socket button cap screws from back to front.

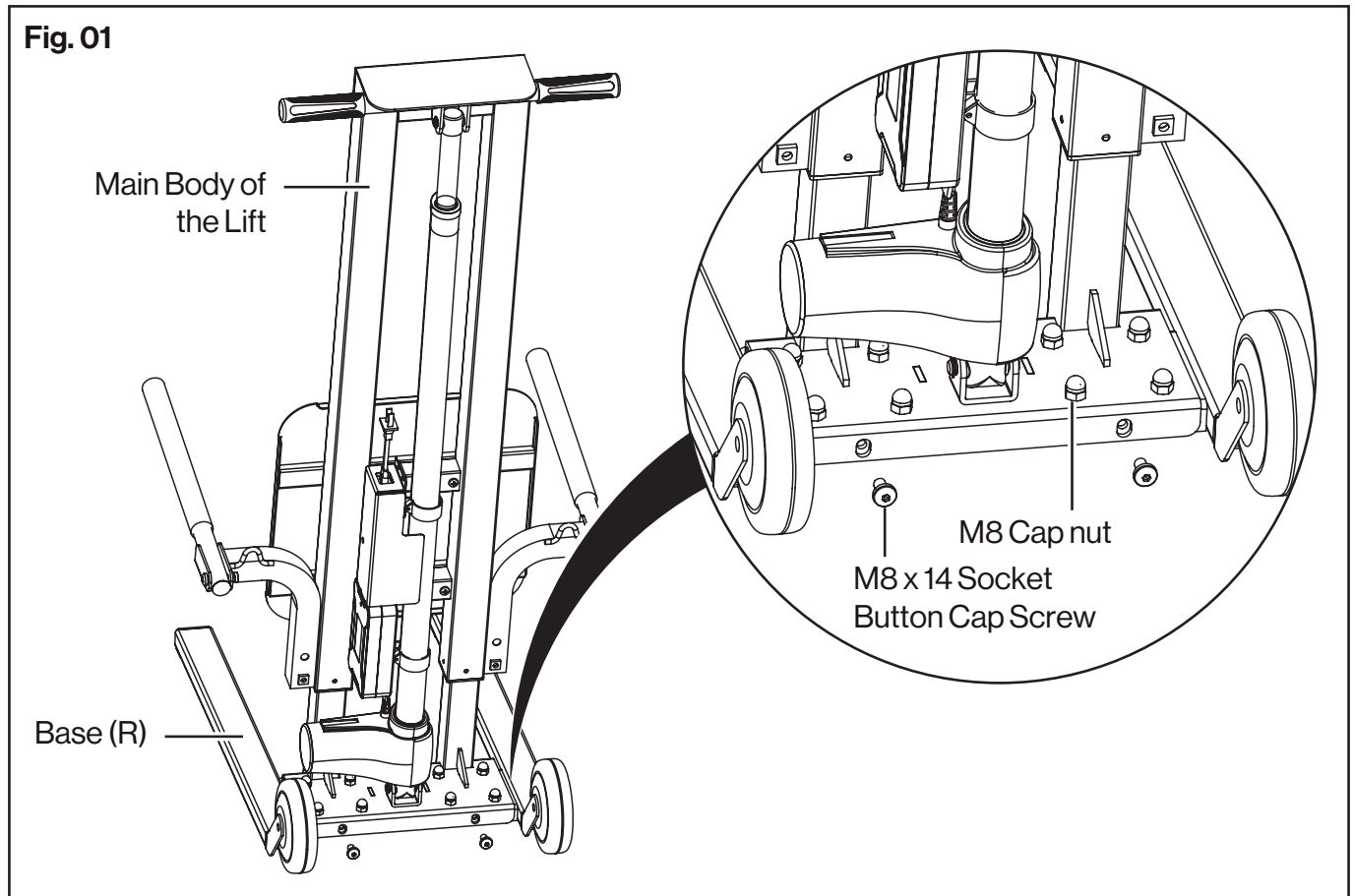

### 5.2 Wired Remote Connector (See Fig.02)

Connect the connector of the wire remote to the connector of the actuator wire as shown in the figure below.

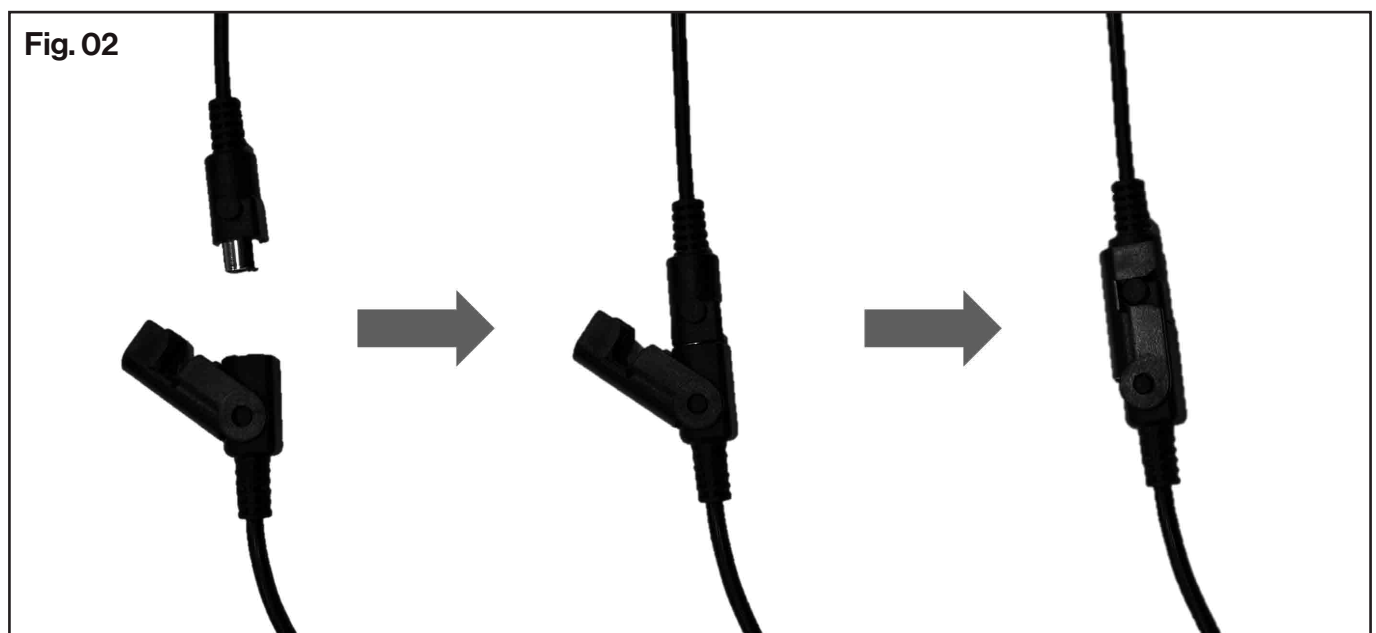

After the connecting, you can place the wired remote on the main body. It will adhere to the surface through magnetic attraction, ensuring that you don't lose the control handle and can easily pick it up and place it back. Just like shown in the figure below. **(See Fig.03)**

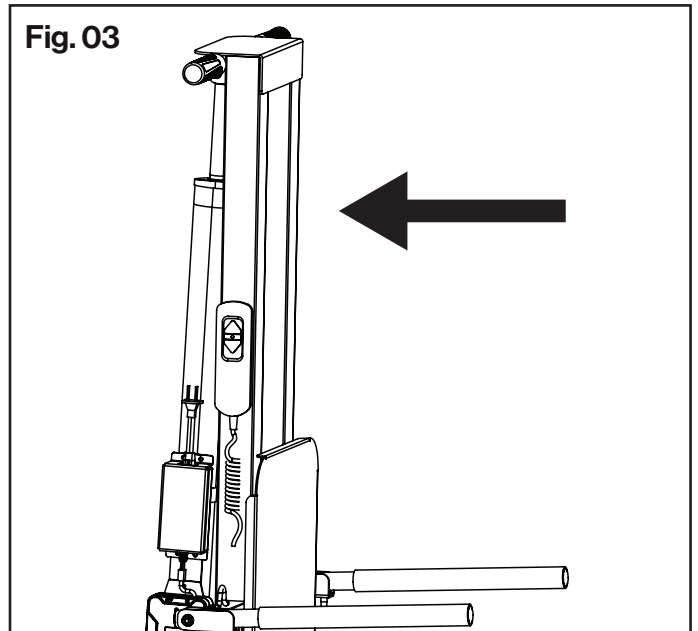

### 5.3 Seat

Press the upward button on the wired remote to raise the floor lift by about 10 inches. Then, place the wired remote back. Now, we can insert the two square tubes of the seat assembly into the square tubes of the floor lift. Align their mounting holes and insert a D-type pin into the holes to secure them in place. Then tighten the socket button cap screws to secure the seat to the main body **(See Fig.04)**

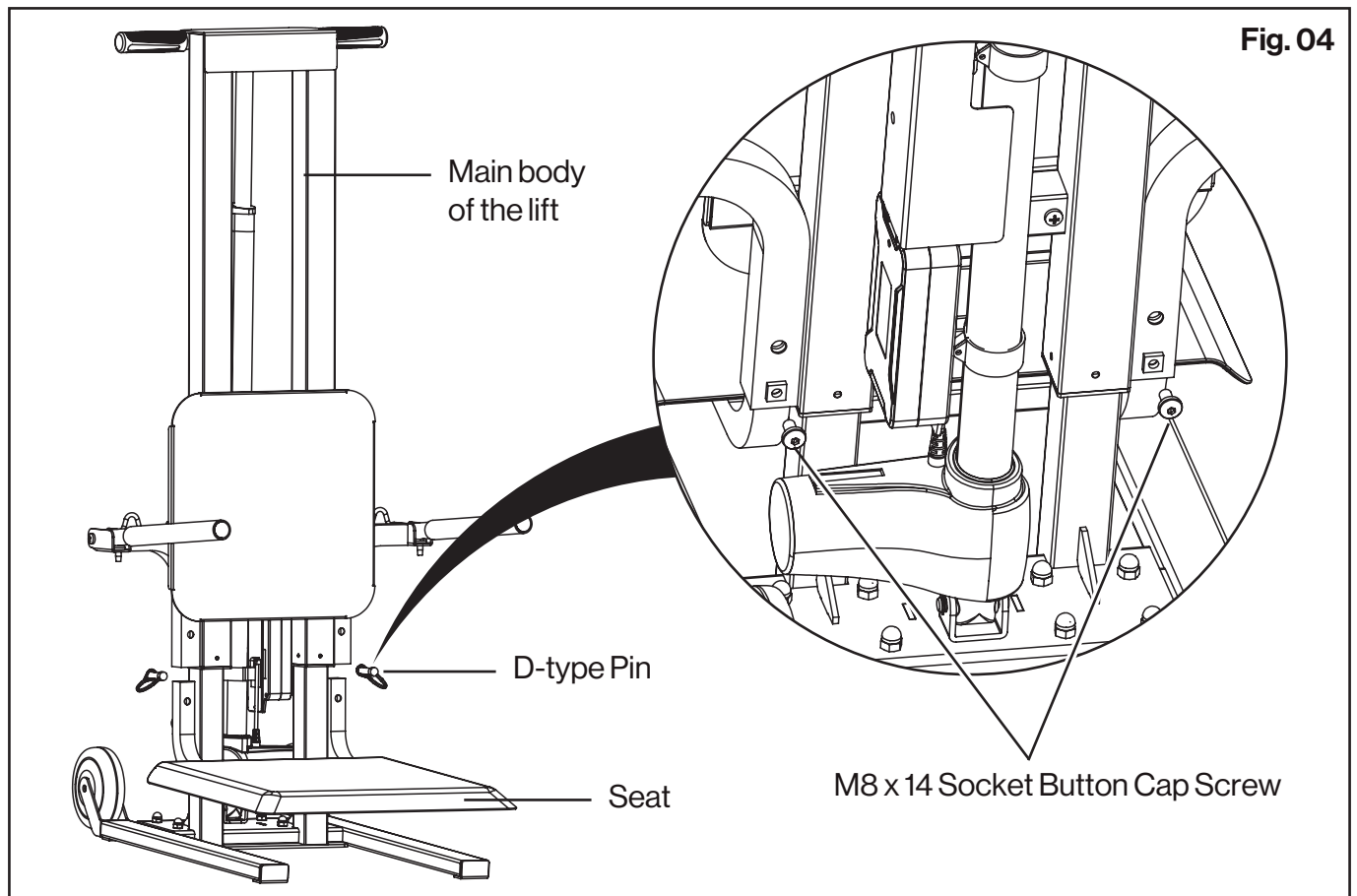

#### 5. 4 Safety Belt (See Fig.05 & Fig.06)

Lock the safety belt's snap hook onto the belt anchor point, just like in the following Figures.

### 6. OPERATION

#### 6.1 Dual Power Mode.

This Floor lift features two power supply modes. When the battery is charged, it can be used directly as described below. In the event of a depleted battery, the power adapter (which also serves as a charger) can be connected to an AC power source for immediate use. The usage procedure remains identical to that when the battery is fully charged.

#### 6.2 Pre-check.

Evaluate whether the user is suitable for the device by considering aspects such as weight, body size, psychological capacity, and joint mobility. Press the up/down button on the remote to ensure the chair automatically tilts backward and confirm that the chair is rising/lowering normally.

#### 6.3 Unbuckle your seat belt. (See Fig.07)

Before the user being lifted moves onto the seat, the safety belt must first be unbuckled, and then the person can be moved onto the seat.

#### 6.4 Fasten the safety belt. (See Fig.08)

After the user has moved onto the seat, it is necessary to lock the safety belt buckle, adjust the length of the safety belt, and ensure that the user is sitting stably on the seat.

#### 6.5 Lifting or Lowering. (See Fig.09)

Hold the up (or down) button on the wired remote, and the user will be lifted (or lowered) to the appropriate position. Releasing the button will stop the ascent (descent).

##### Status indicator:

- **Flashing green light:** When the up or down button is pressed, the light flashing green, indicating that it is ascending or descending.
- **Flashing red light:** Indicates that the battery is low and needs to be charged for future use. (In emergency situations, if the battery is insufficient, the device can be directly connected to an AC power supply (100-240V, 50/60Hz) for operation).

**Note:** The maximum travel distance for lifting or lowering is 27.6in (700mm). When the seat is at its highest position, holding the up button will not allow it to rise further; similarly, when the seat is at its lowest position, holding the down button will not allow it to descend further.

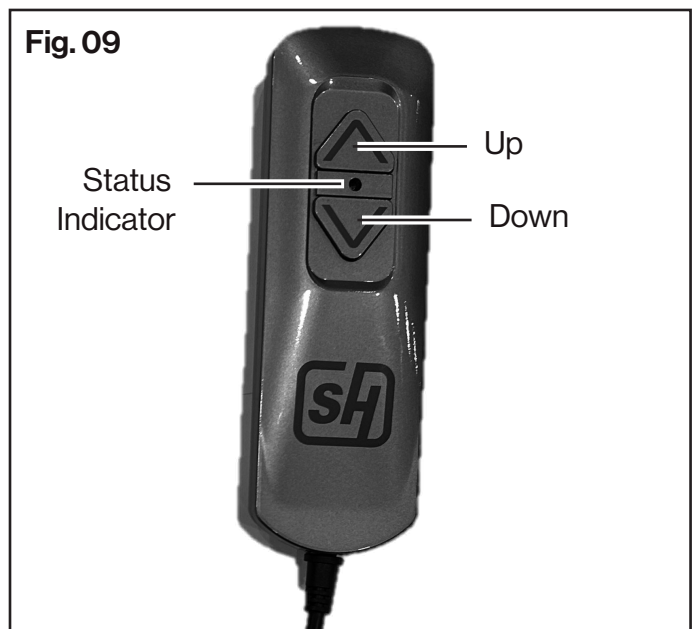
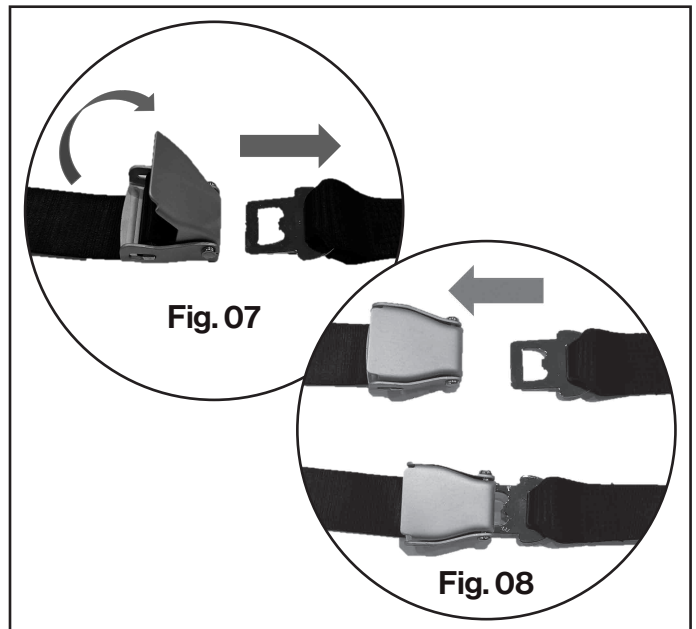
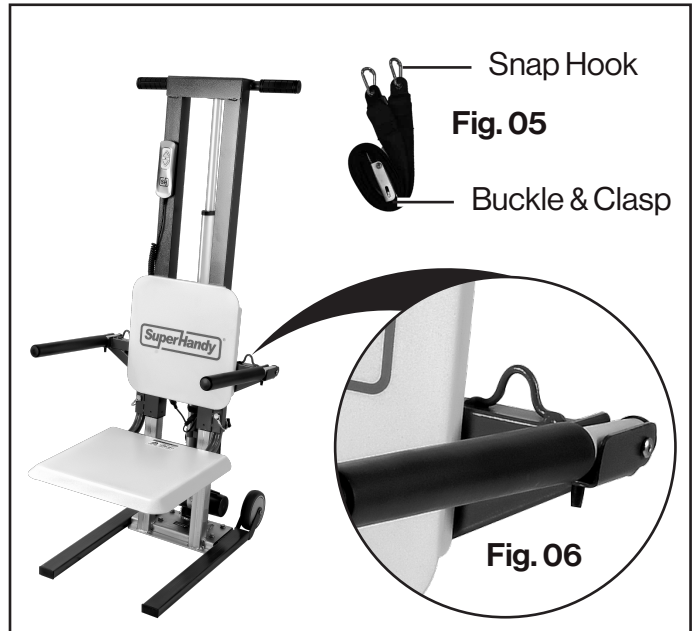

### 6.6 Battery Charging. (See Fig.10)

When the status indicator on the wired remote flashes red, it indicates that the battery needs to be charged. Connect the charger (power adapter) to an AC power source (100-240V, 50/60Hz), the AC power indicator on the charger will turn green, signifying that the charger is now working. During normal charging, the battery charging indicator on the battery pack will turn red, and it will change to green when the battery is fully charged. The charging process typically takes about 4 hours.

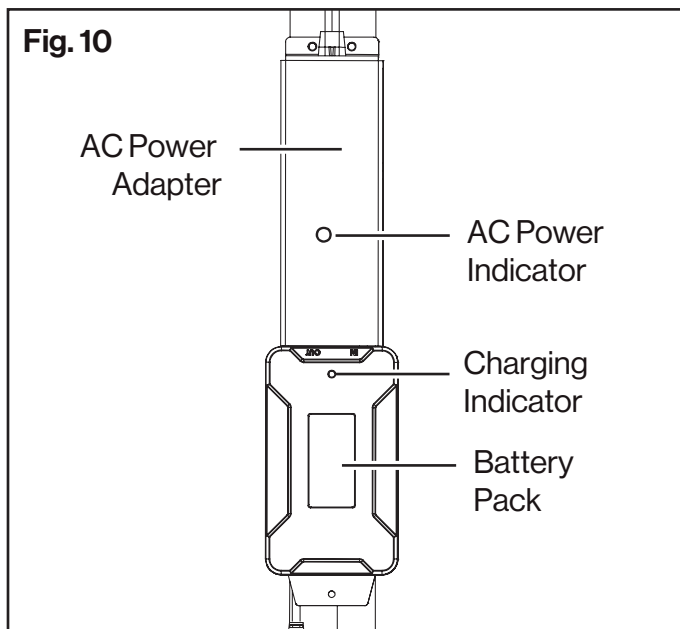

## 7. MAINTENANCE & STORAGE

- The floor lift does not require regular maintenance. Keeping the battery charged helps to extend its lifespan.
- Although the floor lift is very durable and functions well both indoors and outdoors, it is recommended to store it indoors when not in use.

## 8. WARRANTY

Warranty covers twelve (12) months for workmanship of the product, except for wearing parts. Warranty period starts from the product purchase date. Warranty covers material quality and workmanship only. Warranty does not cover product for issues caused by improper usage or any operation not in accordance with the specifications of this manual. Any modification or tampering with the product in any way voids the warranty.



Thank you for your most recent purchase.

superhandyus.com



Great Circle USA  
Support Line: 1-866-493-0524  
help@greatcircleus.com  
www.superhandyus.com



Follow us on social media  
@SuperHandy