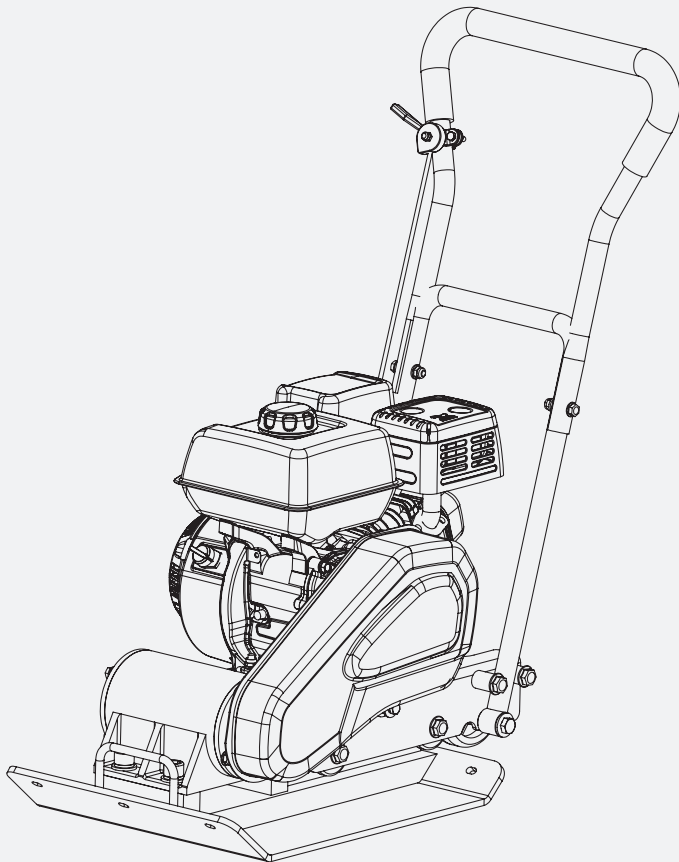



Plate Compactor | GUO118

Operator's Manual



Warning: Please read and thoroughly understand all instructions before operating. Failure to follow safety rules and other basic safety precautions may result in serious personal injury. Keep these instructions in a safe and easily accessible place so that they can be referred to when needed. Retain these instructions to assist in future servicing.



INDEX

1. WARNING -----	1-4
2. TECHNICAL SPECIFICATIONS -----	4
3. FEATURES -----	5
4. ASSEMBLY -----	4-9
5. OPERATION -----	10-11
7. MAINTENANCE -----	11-14
8. WARRANTY -----	14
9. TROUBLE SHOOTING -----	15

1. WARNING

Your new Vibratory Plate Compactor will more than satisfy your expectations. It has been manufactured under stringent quality standards to meet superior performance criteria. You will find it easy and safe to operate, and with proper care, it will give you many years of dependable service.



Carefully read through this entire operator's manual before using your new Log Splitter. Take special care to heed the cautions and warnings.

1. The commitment to quality has been designed into details: reinforced self-cleaning base plate, engine oil drain hose, closed V-belt guard, self-adjusting centrifugal clutch and folding handle. A range of useful accessories enables use in all kinds of applications.
2. The Plate Compactor applies energy to the loose soil or other materials to increase its density and load bearing capacity, mainly used for small repair and maintenance work. The loose soil or particles are moved or rearranged in a particular manner close to each other to avoid any trapped air or voids. It increases the load bearing capacity, decreases water seepage, prevents soil settlement, reduces swelling, contraction of the soil and prevents frost damage. It is ideal for compaction of granular soils, sands, gravel, crushed aggregate and mixed soils.



These compactors are not intended to be used on cohesive soils such as clay or hard surfaces like concrete.

1. The Engine Manufacturer is responsible for all engine-related issues with regards to performance, power rating, specifications, warranty and service. Please refer to the Engine Manufacturer's owner/operator's manual, packed separately with your unit, for more information.

General Safety Rules

Understand Your Machine

1. Read and understand the operator's manual and labels affixed to the machine. Learn its application and limitations as well as the specific potential hazards peculiar to it.
2. Be thoroughly familiar with the controls and their proper operation. Know how to stop the machine and disengage the controls quickly.
3. Make sure to read and understand all the instructions and safety precautions as outlined in the Engine Manual, packed separately with your unit. Do not attempt to operate the machine until you fully understand how to properly operate and maintain the Engine and how to avoid accidental injuries and/or property damage.

Work Area

1. Never start or run the engine inside a closed area. The exhaust fumes are dangerous, containing carbon monoxide, an odorless and deadly gas. Operate this unit only in a well ventilated outdoor area.
2. Never operate the machine without good visibility or light.

Personal Safety

1. Do not operate the machine while under the influence of drugs, alcohol, or any medication that could affect your ability to use it properly.
2. Dress properly. Wear heavy long pants, boots and gloves. Do not wear loose clothing, short pants, jewelry of any kind. Secure long hair so it is above shoulder level. Keep your hair, clothing and gloves away from moving parts. Loose clothes, jewelry or long hair can be caught in moving parts.
3. Check your machine before starting it. Keep guards in place and in working order. Make sure all nuts, bolts, etc. are securely tightened.
4. Never operate the machine when it is in need of repair or is in poor mechanical condition.
5. Replace damaged, missing or failed parts before using it. Check for fuel leaks. Keep the machine in safe working condition.
6. Do not use the machine if the engine's switch does not turn it on or off. Any gasoline powered machine that can not be controlled with the engine switch is dangerous and must be replaced.

7. Form a habit of checking to see that keys and adjusting wrenches are removed from machine area before starting it. A wrench or a key that is left attached to a rotating part of the machine may result in personal injury.
8. Stay alert, watch what you are doing and use common sense when operating the machine.
9. Do not overreach. Do not operate the machine while barefoot or when wearing sandals or similar lightweight footwear. Wear protective footwear that will protect your feet and improve your footing on slippery surfaces. Keep proper footing and balance at all times. This enables better control of the machine in unexpected situations.
10. Avoid accidental starting. Be sure the engine's switch is off before transporting the machine or performing any maintenance or service on the unit. Transporting or performing maintenance or service on a machine with its switch on invites accidents.

Fuel Safety

1. Fuel is highly flammable, and its vapors can explode if ignited. Take precautions when using to reduce the chance of serious personal injury.
2. When refilling or draining the fuel tank, use an approved fuel storage container while in a clean, well-ventilated outdoor area. Do not smoke, or allow sparks, open flames or other sources of ignition near the area while adding fuel or operating the unit. Never fill fuel tank indoors.
3. Keep grounded conductive objects, such as tools, away from exposed, live electrical parts and connections to avoid sparking or arcing. These events could ignite fumes or vapors.
4. Always stop the engine and allow it to cool before filling the fuel tank. Never remove the cap of the fuel tank or add fuel while the engine is running or when the engine is hot. Do not operate the machine with known leaks in the fuel system.
5. Loose the fuel tank cap slowly to relieve any pressure in the tank.
6. Never overfill fuel tank (there should be no fuel above the upper limit mark).
7. Replace all fuel tank and container caps securely and wipe up spilled fuel. Never operate the unit without the fuel cap securely in place.
8. Replace all fuel tank and container caps securely and wipe up spilled fuel. Never operate the unit without the fuel cap securely in place.
9. Avoid creating a source of ignition for spilled fuel. If fuel is spilled, do not attempt to start the engine but move the machine away from the area of spillage and avoid creating any source of ignition until fuel vapors have dissipated.
10. Store fuel in containers specifically designed and approved for this purpose.
11. Store fuel in a cool, well-ventilated area, safely away from sparks, open flames or other sources of ignition.
12. Never store fuel or machine with fuel in the tank inside a building where fumes may reach a spark, open flame, or any other source of ignition, such as a water heater, furnace, clothes dryer and the like. Allow the engine to cool before storing in any enclosure.
13. Machine Use and Care.
14. Never pick up or carry a machine while the engine is running.
15. Do not force the machine. Use the correct machine for your application. The correct machine will do the job better and safer at the rate for which it was designed.
16. Do not change the engine governor settings or over-speed the engine. The governor controls the maximum safe operating speed of the engine.
17. Do not run the engine at a high speed when you are not pounding.
18. Do not put hands or feet near rotating parts.
19. Avoid contact with hot fuel, oil, exhaust fumes and hot surfaces. Do not touch the engine or muffler. These parts get extremely hot from operation. They remain hot for a short time after you turn off the unit. Allow the engine to cool before doing maintenance or making adjustments.
20. If the machine should start to make an unusual noise or vibration, immediately shut off the engine, disconnect the spark plug wire, and check for the cause. Unusual noise or vibration is generally warning of trouble.

21. Use only attachments and accessories approved by the manufacturer. Failure to do so can result in personal injury.
22. Maintain the machine. Check for misalignment or binding of moving parts, breakage of parts and any other condition that may affect the machine's operation. If damaged, have the machine repaired before use. Many accidents are caused by poorly maintained equipment.
23. Keep the engine and muffler free of grass, leaves, excessive grease or carbon build up to reduce the chance of a fire hazard.
24. Never douse or squirt the unit with water or any other liquid. Keep handles dry, clean and free from debris. Clean after each use.
25. Observe proper disposal laws and regulations for gas, oil, etc. to protect the environment.
26. Store idle machine out of the reach of children and do not allow persons unfamiliar with the machine or these instructions to operate it. Machine is dangerous in the hands of untrained users.

Service

1. Before cleaning, repair, inspecting, or adjusting, shut off the engine and make certain all moving parts have stopped. Always make sure the engine's switch is in its "OFF" position. Disconnect the spark plug wire, and keep the wire away from the plug to prevent accidental starting.
2. Have your machine serviced by a qualified repair personnel using only identical replacement parts. This will ensure that the safety of the machine maintained.

Specific Safety Rules

1. To avoid injury, keep hands, fingers and feet away from the base plate. Grip the handle of the plate compactor firmly with both hands.
2. If both hands are holding the handle and your feet are clear of the compactor base, your hands, fingers and feet can not be injured by the compactor base.
3. Always operate the machine from behind, never pass or stand in front of the machine when the engine is running.
4. Never place tools or any other item under the plate compactor.
5. If the unit strikes a foreign object, stop the engine, disconnect the spark plug, thoroughly inspect the machine for any damage, and repair the damage before restarting and operating the machine.
6. Do not overload the machine capacity by compacting too deep in a single pass or at too fast a rate.
7. Never operate the unit at high transport speeds on hard or slippery surfaces.
8. Exercise extreme caution when operating on or crossing gravel drives, walks, or roads. Stay alert for hidden hazards or traffic. Do not carry passengers.
9. Never leave the operating position and leave the plate compactor unattended when the engine is running.
10. Always stop the engine when compacting is delayed or when walking from one location to another.
11. Stay away from the edged of ditches and avoid actions that may cause the plate compactor to topple over.
12. Always ascend slopes carefully, in a direct path and in reverse to prevent the plate compactor from toppling over onto the operator.
13. Always park the unit on a firm and level surface and shut the tool off.
14. To reduce exposure to vibration, limit the hours of operation and take periodic breaks to minimize repetition and rest your hand. Reduce the speed and force in which you do the repetitive movement. Try to fill each day with jobs where operating hand-held power equipment is not required.

Environmental

Recycle unwanted materials instead of disposing of them as waste. All tools, hoses and packaging should be resorted, taken to the local recycling center and disposed of in an environmentally safe way.

Symbols

The rating plate on your machine may show symbols. These represent important information about the product or instructions on its use.



Read these instructions for use carefully.



It is forbidden to remove or tamper with the protection devices and safety devices.



Wear eye protection.
Wear hearing protection.



Keep away from rotating parts.



Wear protective gloves.



Do not touch parts which are hot from operation. Serious burns may result.



Wear safety footwear.



Do not smoke or have open flames.

Use extreme caution when storing, handling and using fuels, as they are highly volatile and explosive in vapor state.



Keep children and bystanders off and away.

2. TECHNICAL SPECIFICATIONS

Item No.	GUO118
Plate Size	20"×15"
Centrifugal Force	4200lbf
Exciter Speed	5500vpm
Compaction Depth	12"
Travel Speed	115FT/min

3. FEATURES

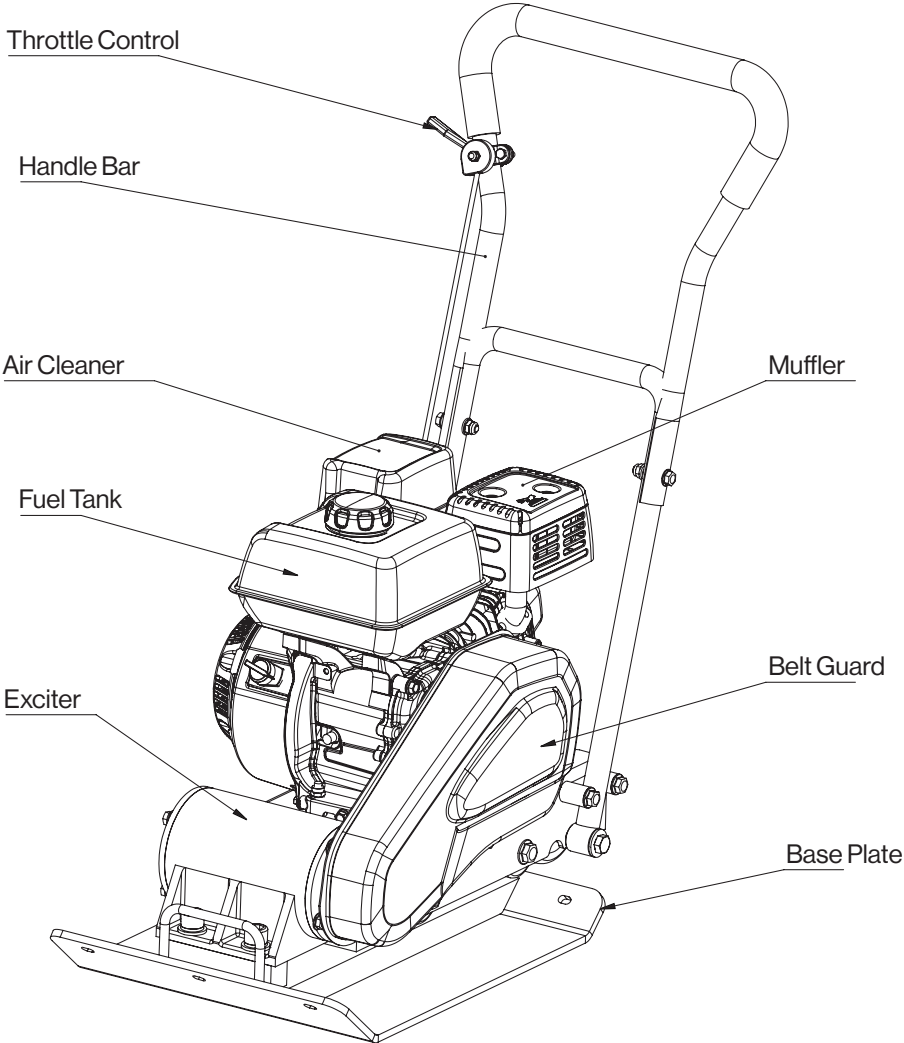

4.ASSEMBLY

Contents Supplied

The plate compactor comes partially assembled and is shipped in carefully packed carton. After all the parts have been removed from the carton, you should have:

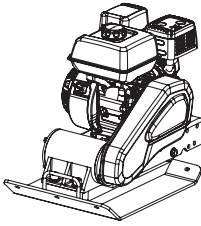

1. Main body of the equipment

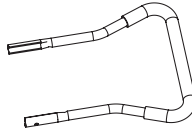

2. Handle

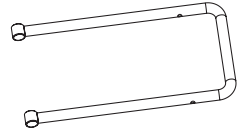

3. Handle Bracket

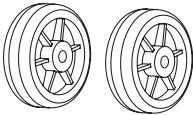

4. Wheels

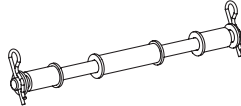

5. Axle

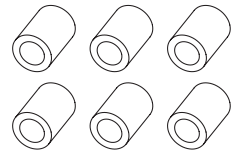

6. Rubber Sleeve

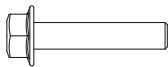

M8*40 hexagon flange bolt, 2pcs



M8 nut, 2pcs

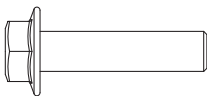

M12*55 hexagon flange bolt, 4pcs



M12 nut, 6pcs

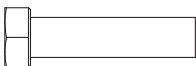

M12*55 hexagon bolt, 2pcs

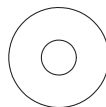

φ12 flat washer, 2pcs

Following the assembly directions below, you will assemble the plate compactor in a few minutes.

1. Handle Bracket

Recommended tools: 17mm wrench*1,
18mm wrench*1

- a. Use 2 M12x55 hexagon flange bolts and 2 M12 nuts to install the rubber sleeves (6) on the hole position shown in the main body of the equipment (1). **(See Fig1-A1)**

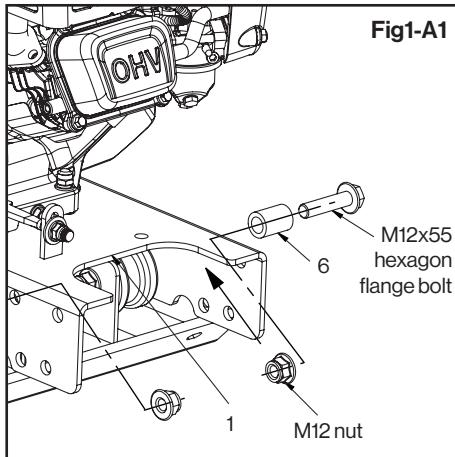

- b. Insert 2 rubber sleeves (6) into the holes on both sides of the handle bracket (3) respectively, and install them on the corresponding mounting holes on the main body of the equipment (1) using 2 M12x55 hexagon bolts, 2 $\phi 12$ flat washers and 2 M12 nuts. **(See Fig1-A2)**

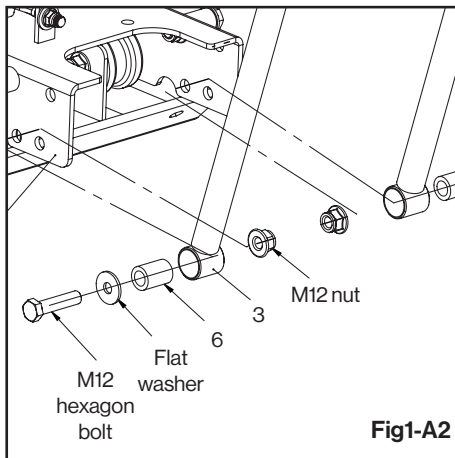

- c. Use 2 M12x55 hexagon flange bolts and 2 M12 nuts to install the rubber sleeves (6) on the hole position shown in the main body of the equipment (1). **(See Fig1-A3)**

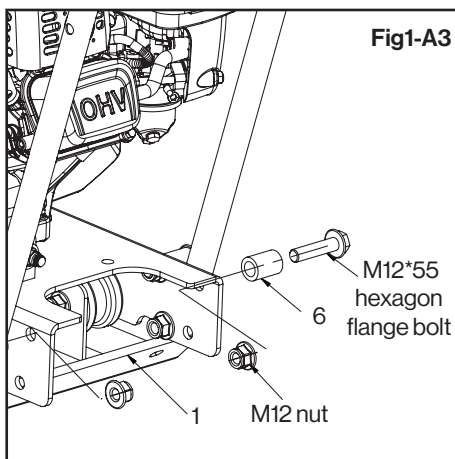

2. Wheels

- a. Remove the R-type pin at one end of the axle (5), and take out the short and long shaft sleeves and flat washers on the axle. (In order to facilitate the installation of the next steps, please place the R-type pin separately from the outermost two flat washers, and place the other parts in the order in which they are removed).

(See Fig2-A1)

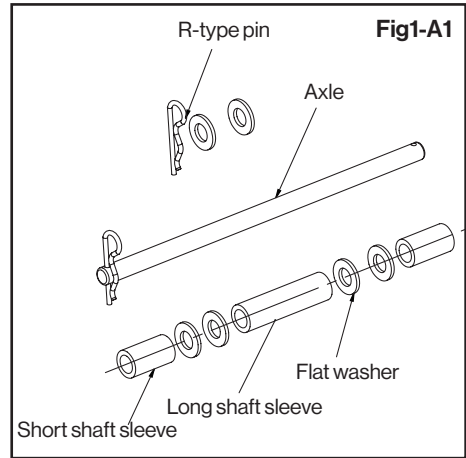
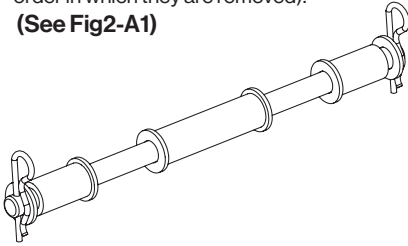

- b. Place the wheels (4) into the accessories (two adjacent flat washers) that have just been placed in order. After passing the axle through a flat washer, insert it from one side of the mounting hole of the main body of the equipment (1), then pass through the parts that have just been arranged, penetrate through the other side of the equipment base through the mounting hole, and finally use the flat washer and the R-type pin to limit the position.

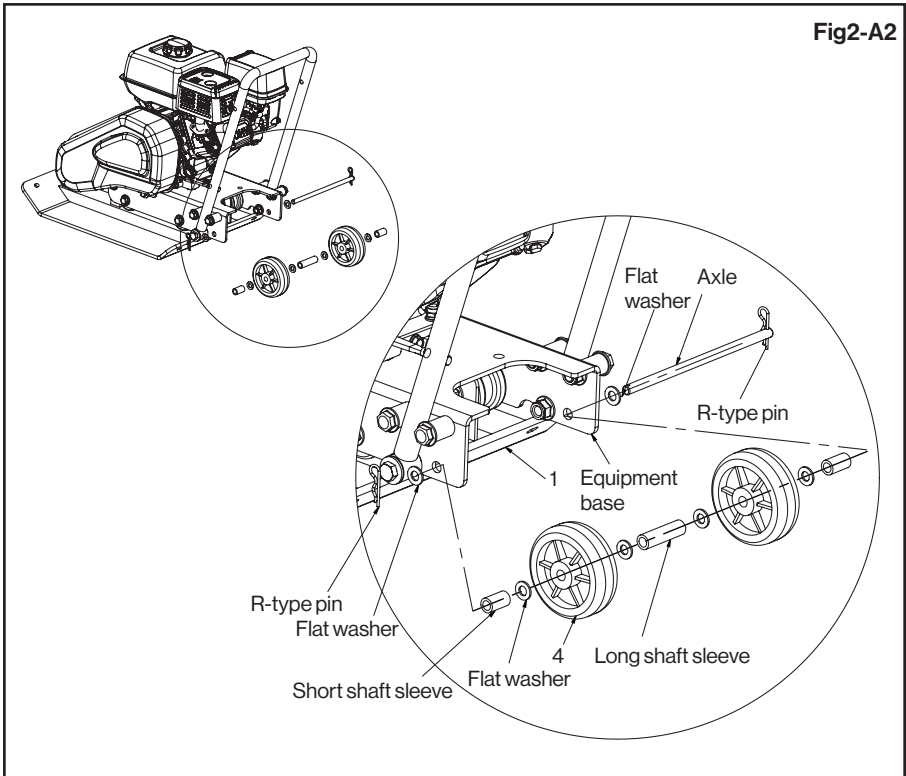

3.Handle

**Recommended tools: 10mm wrench*2,
12mm wrench*1, 13mm wrench*1**

a. Attach the handle (2) to the handle bracket (3) using two M8x40 hexagon flange bolts and two M8 nuts. **(See Fig3-A1)**

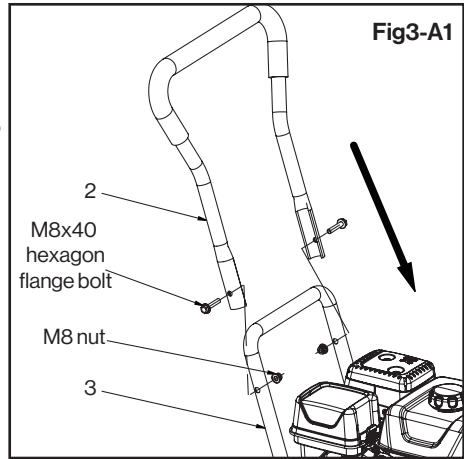

b. Attach the throttle controller to the handle (2) using the included mounting bolts and nuts. **(See Fig3-A2)**

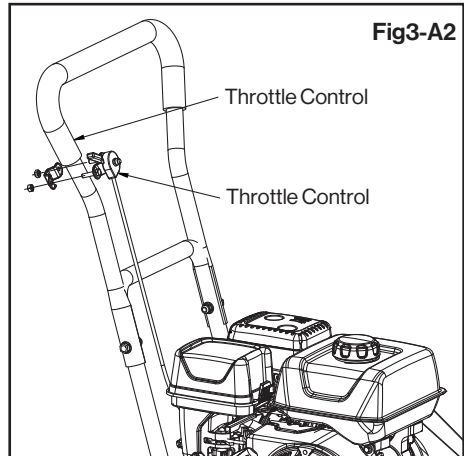

Engine Oil



OIL HAS BEEN DRAINED FOR SHIPPING.

Failure to fill engine sump with oil before starting engine will result in permanent damage and void engine warranty.

Add oil according to Engine Manual packed separately with your tiller.

5. OPERATION

Adding fuel

1. Fill the fuel tank as instructed in the separate Engine Manual packed with the Plate Compactor.
2. More detailed description of the engine operation and all related precautions and procedures can be found in the Engine Manual packed separately with the unit.

Starting Engine

1. Move the fuel valve lever to the ON position.
2. To start a cold engine, move the choke to the CLOSE position. To restart a warm engine, leave the choke lever in the OPEN position.
3. Move the throttle lever away from the SLOW position, about 1/3 of the way toward the FAST position.
4. Turn the engine switch to the ON position.
5. Operate the starter.

Operating



Do not operate plate on concrete or on extremely hard, dry, compacted surfaces. The plate will jump rather than vibrate and could damage both plate and engine.

1. After engine warms up, pull throttle lever to accelerate engine speed. Plate will begin vibrating and move forward.
 2. The plate compactor is designed to run at an engine speed (engine take of shat) of 3600 rpm (Normally considered full throttle). Running the engine at lower rpm's will result in a decrease of compaction force and lower travel speed. It will create excessive "out-of-synch" vibrations resulting in poor compaction, maneuverability. Excessive wear to the machine, and discomfort to the operator.
 3. In operation, guide the machine, but let the compactor do the work. Bearing down on the handle is unnecessary and causes shock absorber wear.
 4. On level surfaces the compactor moves forward rapidly. On uneven surfaces or inclines, light forward pressure on handle may be required to assist the compactor in moving forward.
 5. The number of passes required to reach a desired compaction level will depend on the type and moisture content of soil. Maximum soil compaction has been reached when excessive kickback is noticed.
- When using a compactor on asphalt, Water Sprinkler Kit is required to help prevent the bottom plate from adhering to the hot asphalt surface.
 - When using plate on paving stones, attach a pad to the bottom of the plate to prevent chipping or grinding surface of the stones. A special urethane pad designed for this purpose is available as an optional accessory.
 - While a certain amount of moisture in the soil is necessary, excessive moisture may cause soil particles to stick together and prevent good compaction. If soil is extremely wet, allow it to dry somewhat before compacting.
 - If soil is so dry as to create dust clouds while operating plate, some moisture should be added to the ground material to improve compacting. This will also reduce service to the air filter.

Stopping Engine

To stop the engine in an emergency, simply turn the engine switch to the OFF position.

Under normal conditions, use the following procedure.

1. Move the throttle lever to the SLOW position.
2. Let engine idle for one or two minutes.
3. Turn the engine switch to the OFF position.
4. Turn the fuel valve lever to the OFF position.



Do not move choke control to CLOSE to stop engine. Backfire or engine damage may occur.

Idle Speed

Set throttle control lever to its "low" position to reduce stress on the engine when compacting is not being performed. Lowering the engine speed to idle the engine will help extend the life of the engine, as well as conserve fuel and reduce the noise level of the machine.

Maintenance

Maintaining your compactor will insure long life to the machine and its components.

Preventive Maintenance

1. Turn off engine. Engine must be cool.
2. Keep the engine's throttle lever in its SLOW position, and remove spark plug wire from spark plug and secure.
3. Inspect the general condition of the plate compactor. Check for loose screws, misalignment or binding of moving parts, cracked or broken parts, and any other condition that may affect its safe operation.
4. Remove all debris from the plate compactor with a soft brush, vacuum, or compressed air. Then use a premium quality lightweight machine oil to lubricate all moving parts.
5. Clean the bottom of the compactor base as soon as it begins to pick up soil being compacted. The unit can not do a good job if the bottom surface is not smooth and clean.
6. Replace spark plug wire.



Never use a "pressure Washer" to clean your plate compactor. Water can penetrate tight areas of the unit and cause damage to spindles, pulleys, bearings, or the engine. The use of pressure washers will result in shortened life and reduce serviceability.

Checking V-Belt

To ensure optimum power transmission from the engine to the eccentric shaft, the V-belt must be in good condition and operate under proper tension.

1. Turn off engine. Engine must be cool.
2. Remove the belt guard to access the V-belt.
3. Check the condition of the V-belt. If any V-belt is cracked, frayed, or glazed, it should be replaced as soon as convenient.
4. Check the V-belt tension by squeezing them in the center. The normal deflection on each side should be 9mm (3/8") to 13mm(1/2") with moderate pressure from your thumb or finger.
 - On new machines or after installing a new belt, check belt tension after first 20 hours of operation. Check and adjust belt every 50 hours thereafter.

Tensioning V-Belt

Proper belt tension is critical to good performance.

Proper adjustment will assure long belt life.

Too much or too little belt tension will cause premature belt failure.

1. Loosen 4 engine mount bolts (do not remove) only enough to move the engine forward.

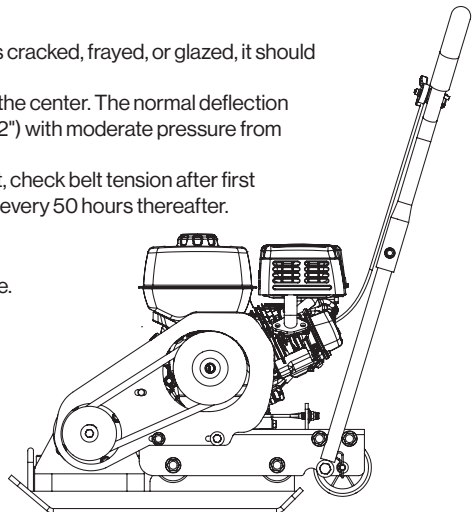

← LOOSEN TIGHTEN →

2. Loosen the jam nuts (A) , leaving enough space between the nut and bracket (B) .

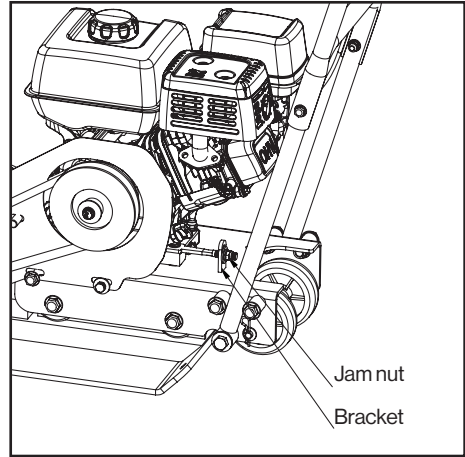

3. Push engine toward the back of the plate to remove any slack in V-belt.
4. When adjusting the belt, make sure that the clutch pulley is in alignment with exciter pulley.

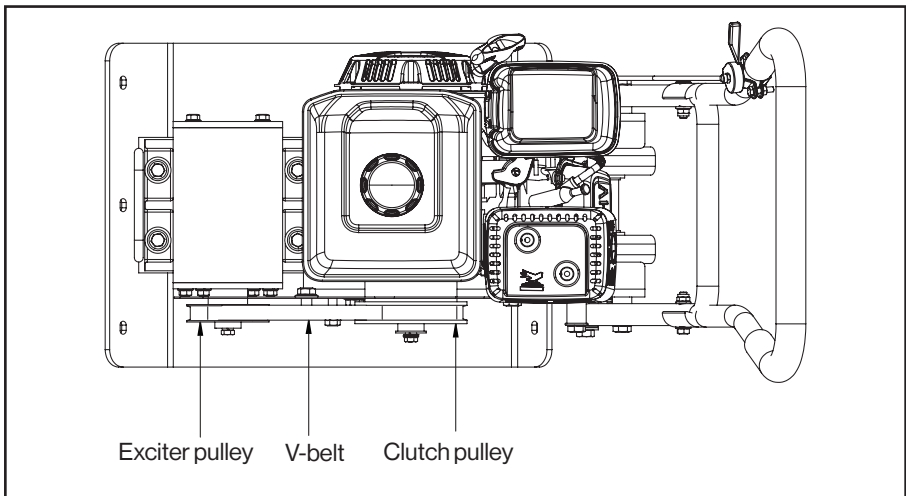

5. When the V-belt tension is correct, tighten the jam nuts A against the bracket.
6. Tighten the engine mount bolts.
7. Replace the belt guard.
• If the adjustment bolts have no more adjustment left, the belt may have to be replaced.

Replacing V-Belt

1. Loose 4 engine mount bolts (do not remove) only enough to move the engine forward.
2. Loosen the jam nuts A shown in above figure.
3. Slide the engine toward the front of plate and slip the old V-belt off of the wheel pulley and install the new V-belt in their place.
4. Position the V-belt over the engine pulley.
5. Move the engine back.



When adjusting the belt, make sure that the clutch pulley is in alignment with exciter pulley.

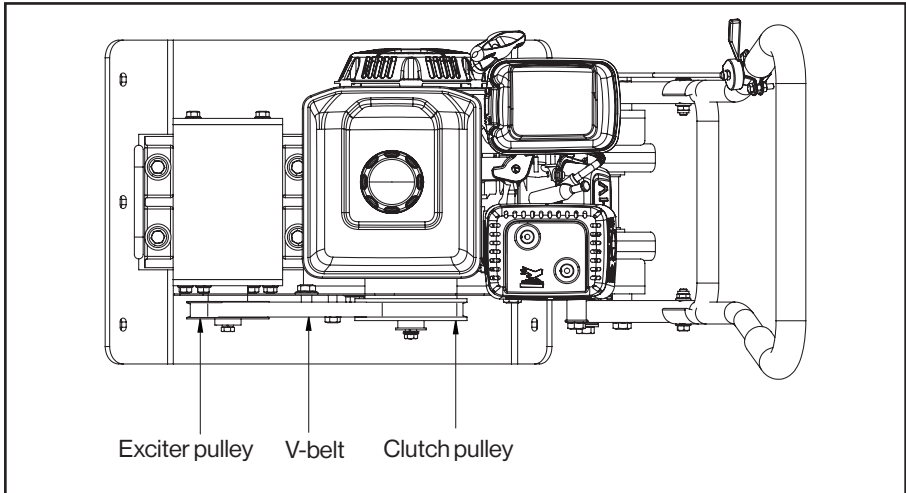

6. When the V-belt tension is correct, tighten the jam nuts A and the engine mount bolts.
7. Replace the belt guard.



When removing or installing the drive belt, be careful not to get your fingers caught between the belt and pulley.

Engine maintenance

Refer to the Engine Manual included in your plate compactor for the information on engine maintenance. Your engine manual provides detailed information for performing the tasks.

Storage

If the plate compactor will not be used for a period longer than 30 days, following the steps below to prepare your unit for storage.

1. Drain the fuel tank completely. Stored fuel containing ethanol or MTBE can start to go stale in 30 days. Stale fuel has high gum content and can clog the carburetor and restrict fuel flow.
2. Start the engine and allow it to run until it stops. This ensures no fuel is left in the carburetor. Run the engine until it stops. This helps prevent deposits from forming inside the carburetor and possible engine damage.
3. While the engine is still warm, drain the oil from the engine. Refill with fresh oil of the grade recommended in the Engine Manual.
4. Allow the engine to cool. Remove the spark plug and put 60 ml of SAE -30 of high quality motor oil into the cylinder. Pull the starter rope slowly to distribute the oil. Replace the spark plug.



Remove the spark plug and drain all of the oil from the cylinder before attempting to start the unit after storage.

5. Use clean cloths to clean off the outside of the compactor and to keep the air vents free of obstructions.



Do not use strong detergents or petroleum based cleaners when cleaning plastic parts. Chemicals can damage plastics.

6. Store your plate compactor in upright position in a clean, dry building that has good ventilation.

TRANSPORTING

See technical data for the weight of the machine.

To avoid burns or fire hazards, let engine cool before transporting machine or storing indoors.

The unit must be transported in the upright position to prevent fuel from spilling. Do not lay machine on its side or top.

Secure or tie down unit using the lifting handle to prevent machine from sliding or tipping over.



Machine may fall and cause damage or injury if lifted incorrectly. Lift using handles at base of plate.

WARRANTY

Twelve (12) months for workmanship of the product, except for wearing parts. Warranty period starts from the product purchase date. Warranty covers material quality and workmanship only. Warranty does not cover product for issues caused by improper usage or any operation not in accordance with the specifications of this manual. Any modification or tampering with the product in any way voids the warranty.

TROUBLE SHOOTING

Problem	Cause	Remedy
Engine fails to start.	<ol style="list-style-type: none"> 1. Spark plug wire disconnected. 2. Out of fuel or stale fuel. 3. Throttle control lever not in correct starting position. 4. Choke not in ON Position. 5. Blocked fuel line. 6. Fouled spark plug. 7. Engine flooding. 	<ol style="list-style-type: none"> 1. Attach spark plug wire securely to spark plug. 2. Fill with clean, fresh gasoline. 3. Move throttle control lever to start position. 4. Throttle must be positioned at choke for a cold start. 5. Clean the fuel line. 6. Clean, adjust gap, or replace. 7. Wait a few minutes to restart, but do not prime.
Engine runs erratically.	<ol style="list-style-type: none"> 1. Spark plug wire loose. 2. Unit running on CHOKE. 3. Blocked fuel line or stale fuel. 4. Vent plugged. 5. Water or dirt in fuel system. 6. Dirty air cleaner. 	<ol style="list-style-type: none"> 1. Connect and tighten spark plug wire. 2. Move choke lever to OFF. 3. Clean fuel line. Fill tank with clean, fresh gasoline. 4. Clear vent. 5. Drain fuel tank. Refill with fresh fuel. 6. Clean or replace air cleaner.
Engine overheats.	<ol style="list-style-type: none"> 1. Engine oil level low. 2. Dirty air cleaner. 3. Air flow restricted. 	<ol style="list-style-type: none"> 1. Fill crankcase with proper oil. 2. Clean air cleaner. 3. Remove blower housing and clean.
Engine will not stop when throttle control is positioned at stop, or engine speed does not increase properly when throttle control is adjusted.	Debris interfering with throttle linkage.	Clean dirt and debris.
Compactor is difficult to control when pounding(machine jumps or lurches forward).	Too high engine speed on hard ground.	Set the throttle lever at lower speed.



Thank you for your most recent purchase.

superhandyus.com



Great Circle USA
Support Line: 1-866-493-0524
help@greatcircleus.com
www.superhandyus.com



Follow us on social media
@SuperHandy