

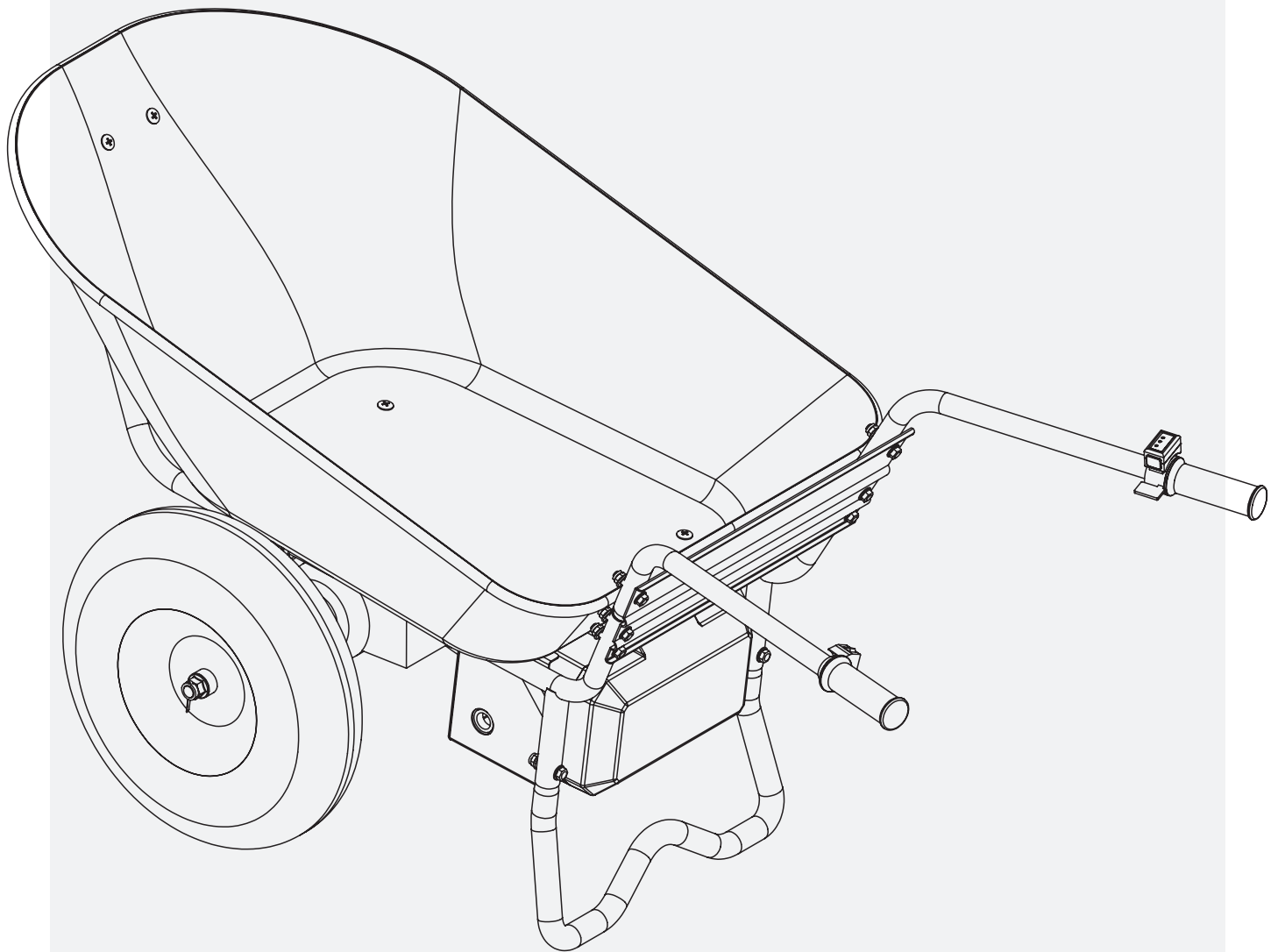

48V Power Barrow | GUO057 Operator's Manual



Warning: Please read and thoroughly understand all instructions before operating. Failure to follow safety rules and other basic safety precautions may result in serious personal injury. Keep these instructions in a safe and easily accessible place so that they can be referred to when needed. Retain these instructions to assist in future servicing.

1. WARNING -----	1-2
2. TECHNICAL SPECIFICATIONS -----	2
3. ASSEMBLY -----	3-4
4. TROUBLESHOOTING -----	4
5. WARRANTY -----	5
6. PARTS BREAKDOWN -----	6

1. WARNING

POWER BARROW SAFETY USE WARNINGS

1. Keep work area clean and well lit. Cluttered or dark areas invite accidents.
2. Do not operate power tools in explosive atmospheres, such as in the presence of flammable liquids, gases or dust. Power tools create sparks which may ignite the dust or fumes.
3. Keep children and bystanders away while operating a power tool. Distractions can cause you to lose control.
4. When operating the machine, stand behind the machine and hold the handles firmly.
5. Do not allow anyone stand in the barrow.
6. When operating the machine in reverse and walking backward, watch behind you and be careful not to slip or trip.
7. Do not use the machine when visibility is poor, because there is a risk of striking obstacles.
8. When operating the machine on rough ground, decrease speed and exercise caution.
9. When using the machine, avoid soft ground to prevent overturn due to the shoulder of the road collapsing.
10. Do not operate the machine on upward slopes greater than 12°.
11. If you find an abnormality, stop the machine on flat ground.
12. The machine, make sure that the lock lever is fully pulled down and completely locked. If the lock is incomplete, there is a risk of accident or injury as the carrier or bucket may be tilted and the objects fall when going downhill.

OPERATION ON SLOPE WARNINGS

1. Do not cross on slopes. Be sure to decrease speed and exercise caution.
2. Exercise caution when starting or stopping the machine on slopes.
3. As the loads become less stable on slopes, firmly secure the loads with ropes
4. As the view is obscured on slopes, keep the height of the load to a minimum
5. Never park the machine on steep slopes. Park the machine on flat ground, and turn off the power.
6. Do not change the direction or speed mode on steep slopes.
7. Do not release the switch trigger on upward slopes. The machine may go in reverse and cause an accident.
8. Make sure that the remaining battery capacity is enough before operating on slopes. If the remaining battery capacity is not enough, charge the battery or replace it with a charged one.

LOADING OBJECTIVE WARNINGS

1. Do not overload objects. When loading objects, be sure to follow the instructions and load limits in the manual.
2. Firmly secure the objects with ropes.
3. Load the objects within the bucket. If the objects protrude from the bucket, there is a risk of accidents due to the objects falling or contact obstacles such as walls.
4. Be sure that loaded objects are below eye level. If the load is too high, it is dangerous because the view is obscured. Also, there is a risk of overturning and injury because the load is likely to be unbalanced.
5. Load the objects on the carrier or bucket evenly. If the objects are loaded unevenly, there is a risk of overturning and injury because the load is likely to be unbalanced.
6. When lifting and tilting the carrier or bucket, hold the handles and frame firmly, and work in a stable posture.

BATTERY POWER TOOL USE AND CARE WARNINGS

1. Ensure the switch is in the off position before inserting battery pack. Inserting the battery pack into power tools that have the switch on invites accidents.
2. Recharge only with the charger specified by the manufacturer. A charger that is suitable for one type of battery pack may create a risk of fire when used with another battery pack.
3. Use power tools only with specifically designated battery packs. Use of any other battery packs may create a risk of injury and fire.
4. When battery pack is not in use, keep it away from other metal objects like paper clips, coins, keys, nails, screws, or other small metal objects that can make a connection from one terminal to another. Shorting the battery terminals together may cause burns or fire.

5. Under abusive conditions, liquid may be ejected from the battery; avoid contact. If contact accidentally occurs, flush with plenty of soap and water. If liquid contacts eyes, immediately seek medical help. Liquid ejected from the battery may cause irritation or burns.
6. Avoid body contact with earthed or grounded surfaces, such as pipes, radiators, ranges and refrigerators. There is an increased risk of electric shock if your body is earthed or grounded.
7. Do not expose power tools to rain or wet conditions. Water entering a power tool will increase the risk of electric shock.
8. Do not abuse the cord. Never use the cord for carrying, pulling or unplugging the power tool. Keep cord away from heat, oil, sharp edges or moving parts. Damaged or entangled cords increase the risk of electric shock.
9. When operating a power tool outdoors, use an extension cord suitable for outdoor use. Use of a cord suitable for outdoor use reduces the risk of electric shock.

PERSONAL SAFETY WARNINGS

1. This is not a toy. Children under 14 years of age are not allowed to operate it.
2. Stay alert, watch what you are doing and use common sense when operating a power tool. Do not use a power tool while you are tired or under the influence of drugs, alcohol or medication.
3. Use personal protective equipment. Always wear eye protection. Protective equipment such as dust mask, non-skid safety shoes, hard hat, or hearing protection used for appropriate conditions will reduce personal injuries.
4. Prevent unintentional starting. Ensure the switch is in the off-position before connecting to power source and/or BATTERY pack, picking up or carrying the tool.
5. Remove any adjusting key or wrench before turning the power tool on. A wrench or a key left attached to a rotating part of the power tool may result in personal injury.
6. Do not overreach. Keep proper footing and balance at all times. This enables better control of the power tool in unexpected situations.
7. Dress properly. Do not wear loose clothing or jewelry. Keep your hair, clothing and gloves away from moving parts.
8. If devices are provided for the connection of dust extraction and collection facilities, ensure these are connected and properly used. Use of dust collection can reduce dust-related hazards.
9. Does not let familiarity gained from frequent use of tools allow you to become complacent and ignore tool safety principles. A careless action can cause severe injury within a fraction of a second.
10. Always wear protective goggles to protect your eyes from injury when using power tools.
11. It is an employer's responsibility to enforce the use of appropriate safety protective equipment's by the tool operators and by other persons in the immediate working area.

2. TECHNICAL SPECIFICATIONS

SKU#	GU0057
Rating	48 Volt DC / 180W
Loading Capacity	330lbs / 150kgs
Battery Specification	48V, 4Ah
Speed	Forward: 0-5km/h(0-3MPH) Variable, Reverse: 0-3.5km/h(0-2.2MPH) Variable
Max. Cubag	Max. 3 Cubic Feet

3. ASSEMBLY

3.1 Fix drive axle(B) on bucket bracket(D) with four bolts M8x45(A) and four nuts M8(C). (See Fig.01)

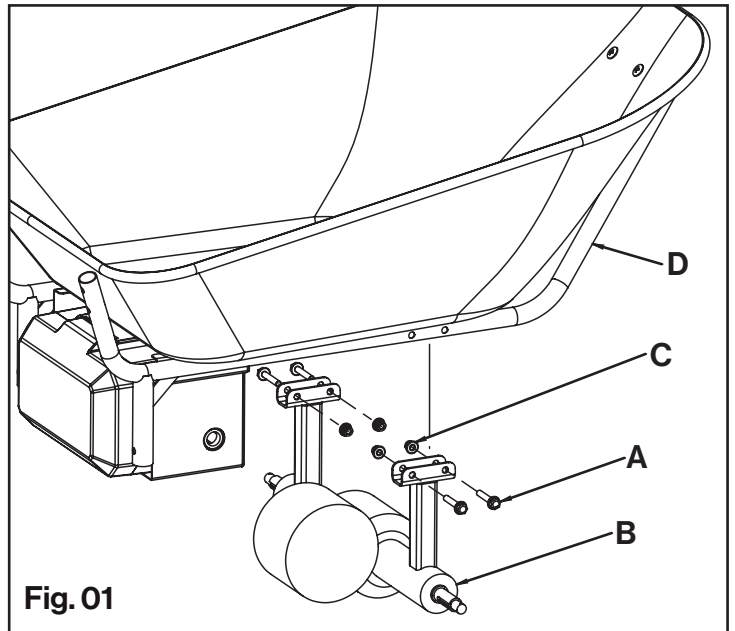

3.2 Fix wheels(D) on the drive axle(E) with flat washer(C), Bolts M14(B), pin 2.8x30(A). (See Fig.02)

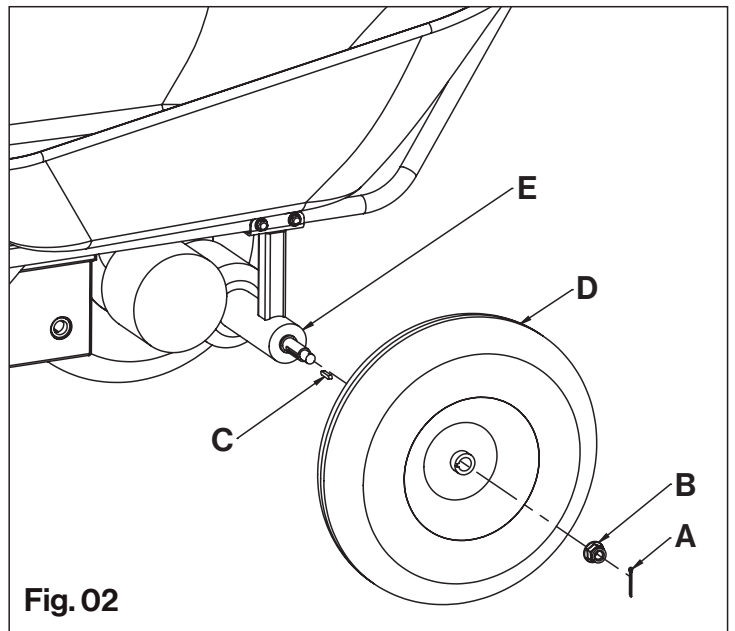

3.3 Fix supporting leg(A) on bucket bracket(D) with two bolts M8x40(B) and two nuts M8(C). (See Fig.03)

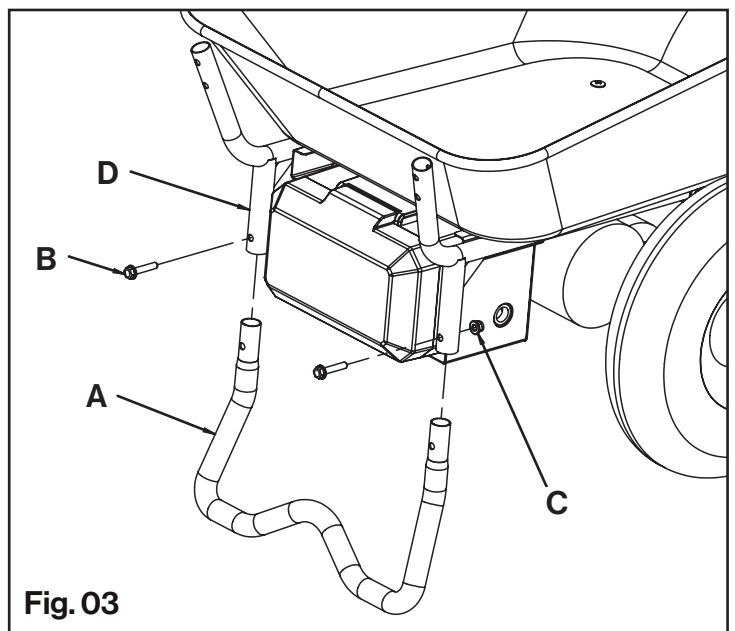

3.4 Fix the left handle-bar(A), the right handle-bar(B) and the handle-bar connecting plate(C) on bucket bracket(F) with three bolts M8x40(D) and three nuts M8(E). When installing, first insert all M8X40 bolts into the fixing holes, and then fix the nuts. (See Fig.04)

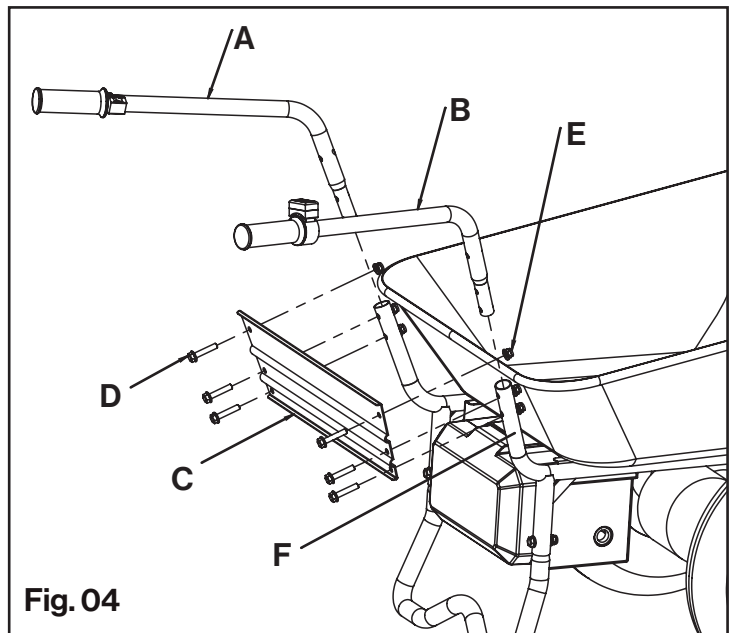

Fig. 04

4. TROUBLESHOOTING

Problem(s)	Possible Cause	Corrective Action
The power barrow does not run.	1. Battery is not charged.	1. Charge the battery pack according to the instructions included with you model.
	1. The wire is loose.	1. Check all the connectors and to see if any partis loose or not.
	1. The controller is damaged.	1. Replace the damaged one with specific controller.
The power barrow runs sluggishly.	1. Battery volume is low.	1. See the battery indicator to check the volume. 2. Charge the battery pack according to the instructions included with you model.
	1. The battery is old and does not accept full charge.	1. Replace the battery with a new one.
	1. The conditions are too stressful for your power barrow.	1. The barrow is intended for residential use. 2. If slopes are too steep or the terrain too bumpy, your barrow might experience a noticeable decrease in performance.

5. WARRANTY

⚠ WARNING

All new machinery is supplied with limited 12 months Warranty.

1. The manufacturer warrants this electric power barrow against defects in material and craftsmanship, for a period of 12 months from date of original purchase.
2. Items considered as consumable parts are not normally covered by the warranty, including but not limited to: Batteries, Electric cables; Filters.
3. This warranty excludes parts that are worn or damaged due to normal wear, routine tune up or adjustment, abuse/misuse or neglect, overheating lack of maintenance, fittings/fasteners becoming loose/detached through lack of maintenance.
4. The warranty does not cover damage caused by accident, misuse or faulty installation, improper handling, routine maintenance items such as O-rings, seals, and lubricants, accessory parts.
5. The electric power barrow must be installed and maintained in compliance with the instructions.

6. PARTS BREAKDOWN

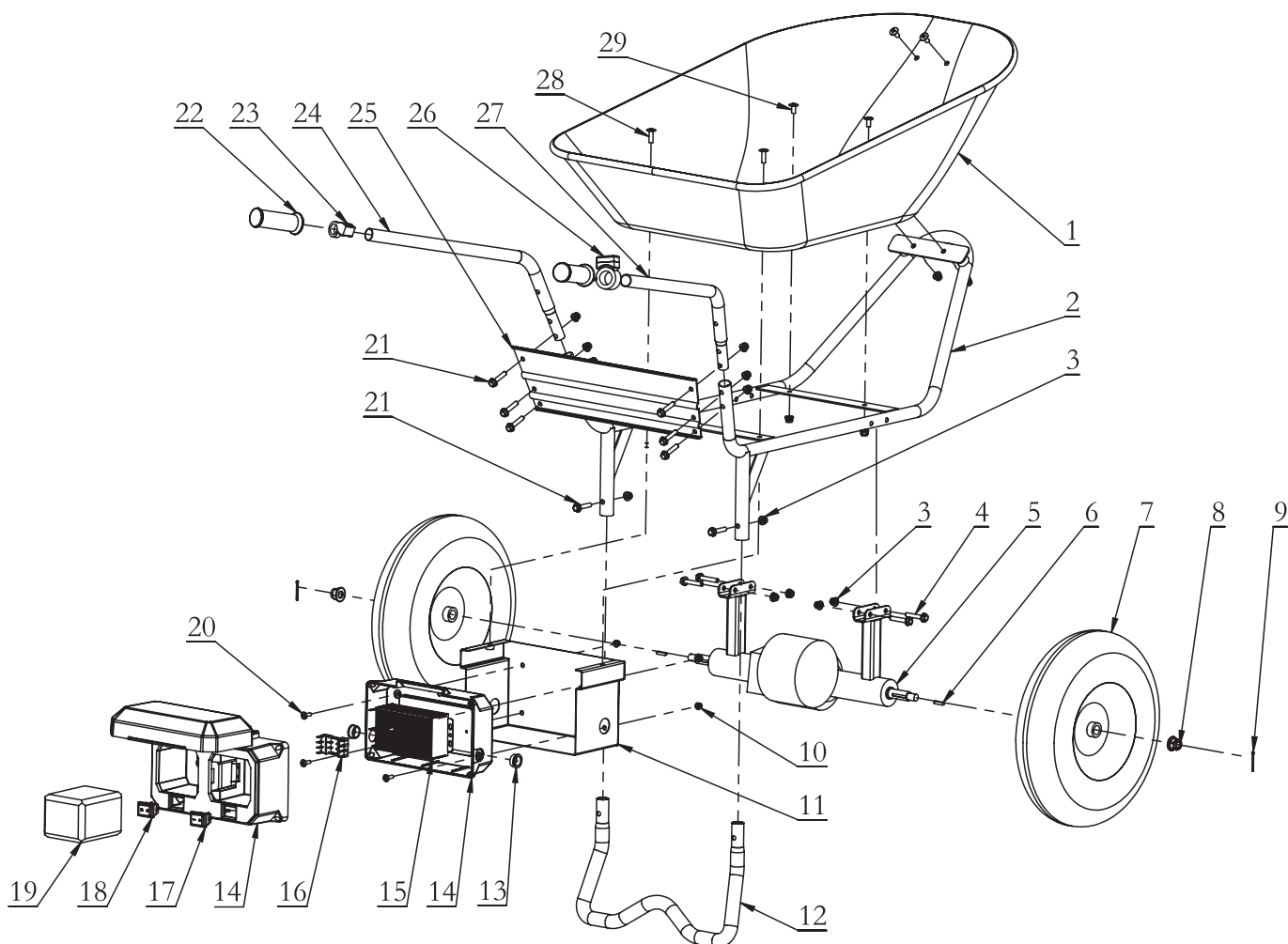

Part No.	Description	Q'ty	Part No.	Description	Q'ty
1	Bucket	1	16	Connection socket	2
2	Bucket Base	1	17	Power switch	1
3	Flange nut M8	16	18	Switch	1
4	Flange Bolt M8x45	4	19	Lithium battery	1
5	Drive axle	1	20	Flat head screw M6x20	4
6	Flat key	2	21	Flange Bolt M8x40	8
7	Wheel assembly	2	22	Handlebar grips	2
8	Bolt M14	2	23	Direction controller	1
9	Pin	2	24	Left handle	1
10	Bolt M6	4	25	Handlebar connection plate	1
11	Battery box bracket	1	26	Speed controller	1
12	Supporting leg	1	27	Right handle	1
13	Protector	2	28	Flat head screw M8x25	2
14	Battery box	1	29	Flat head screw M8x16	4
15	Controller	1			



Thank you for your most recent purchase.

superhandyus.com



Great Circle USA
Support Line: 1-866-493-0524
help@superhandyus.com
www.superhandyus.com



Follow us on social media
@SuperHandy