

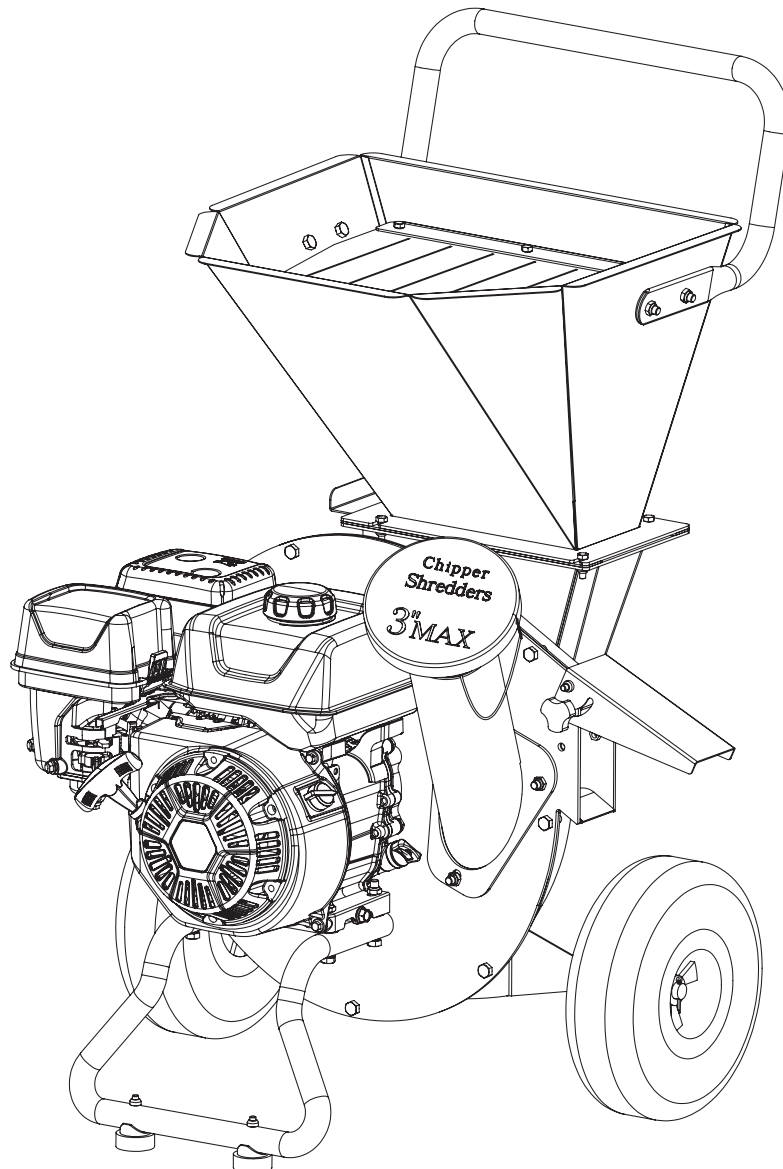

Chipper Shredder

Instruction Manual



WARNING:

Read carefully and understand all **INSTRUCTIONS** before operating. Failure to follow the safety rules and other basic safety precautions may result in serious personal injury. Save these instructions in a safe place and on hand so that they can be read when required. Keep these instructions to assist in future servicing.







WARNING SYMBOL



WARNING: This is the warning symbol to get your high attention for the instruction notice, which should be followed to avoid the potential serious personal injury. Anyone to use this equipment should read all the instructions of this manual. Keep this instruction manual for future reference.

Do not allow children to operate this chipper shredder. Keep small children away from the area while chipper shredder is in use. Do not allow adults to operate the chipper shredder without proper instruction.

WARNING SYMBOLS AND DEFINITIONS

 DANGER	DANGER INDICATES A SERIOUS INJURY OR FATALITY WILL RESULT IF THE SAFETY INSTRUCTIONS THAT FOLLOW THIS SIGNAL WORD ARE NOT OBEYED.
 WARNING	WARNING INDICATES A HAZARD WHICH, IF NOT AVOIDED, COULD RESULT IN DEATH OR SERIOUS INJURY AND/OR PROPERTY DAMAGE.
 CAUTION	CAUTION INDICATES YOU CAN OR YOUR EQUIPMENT CAN BE HURT IF THE SAFETY INSTRUCTIONS THAT FOLLOW THIS SIGNAL WORD ARE NOT OBEYED.
 IMPORTANT	IMPORTANT INDICATES HELPFUL INFORMATION FOR PROPER ASSEMBLY, OPERATION, OR MAINTENANCE OF YOUR EQUIPMENT.

Intended Use

Foreseeable Misuse

This is a petrol engine-powered chipper shredder that breaks up leaves and wooded pieces such as tree branches, brush, and limbs into smaller volume via a high-speed rotor containing chipping blades and shredding hammers. It shall not be used for any other purpose.

WARNING

1. You must read, understand and comply with all safety and operating instructions in this manual before attempting to setup and operate your chipper shredder.
2. Failure to comply with all safety and operating instructions can result in loss of machine control, serious personal injury to you and/or bystanders, and risk of equipment and property damage. The triangle in the text signifies important cautions or warnings which must be followed.

WARNING

1. Engine exhaust, wood dust, and gasoline vapors from this product contains chemicals known to the state of California
2. To cause cancer, birth defects, or other reproductive harm.

INDEX

Features	1
Specifications	1
Safety	2-4
Assembly	5
Operation	6-7
Transporting and Storage	7-8
Maintenance	8-9
Trouble Shooting	10
Repair	11
Parts Breakdown	12-14
Warranty	14
Optional Accessory	15-16

FEATURES

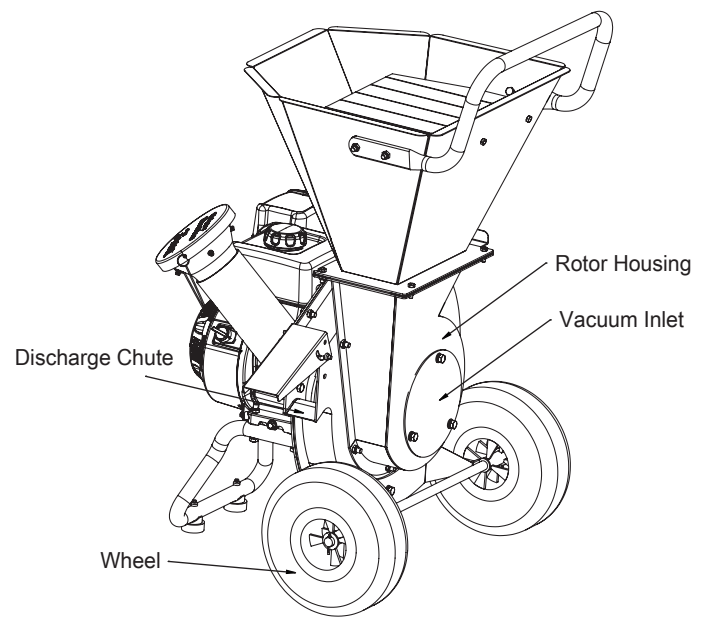
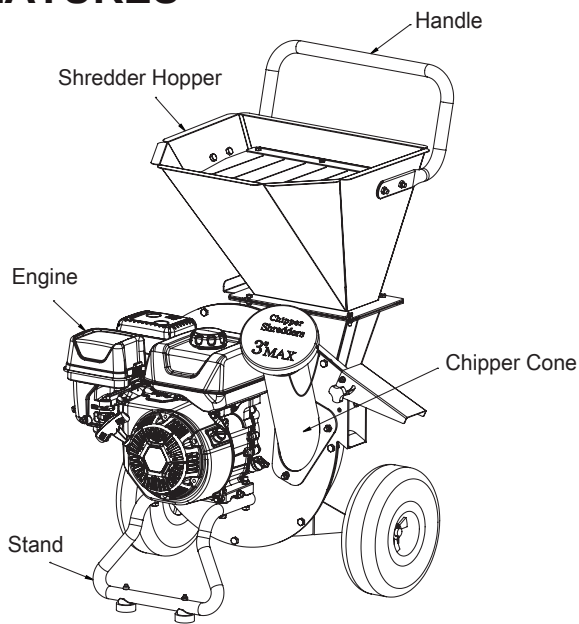

SPECIFICATIONS

Item No.	LCE01
Chipping Capacity	Max. 3"
Shredder Capacity	1/2"
Chipping Knives	2
Shredder Hammer	4 Y-HAMMERS
Reduction Rate	15:1
Chipper Knife Material	CR12MoV
Hopper Dimensions (IN)	16.7X15.2
Limb Chute	YES
Wheel Size (IN)	10x3
Wheel Material	PU
Wheel Type	SOLID
Net Weight (LB)	116
Gross Weight (LB)	127
Assembled Dimension (IN)	30x24.1x41
Packing Dimension (IN)	31.9x23.8x22.2

Engine Specifications

Engine Brand	Alphaworks
Engine Type	OHV
Power	7HP
Starting	Recoil
RPM	3600
Fuel Capacity	0.7Gal
Oil	10W-30 for 32°F & above 5W-30 for 25°F & below
EPA3 Approval	YES
CARB Approval	YES

GENERAL OPERATING SAFETY

1. Read, understand, and follow all instructions in the manual and on the unit before starting
2. Locate the Chipper/Shredder on a flat, level, sturdy surface capable of supporting the weight of the Chipper / Shredder and any additional tools and equipment.
3. Do not attempt to use the machine on a slope or slick surface.
4. Dress appropriately when operating the chipper shredder. Always wear sturdy footwear and safety goggles. Never wear sandals, sneakers or open shoes, and never operate the chipper shredder with bare feet. Do not wear loose clothing that might get caught in moving parts.
5. Never place your hands, fingers, feet, or any other part of your body close to the Discharge Opening while the Chipper/Shredder is in operation.
6. Do not look into the Hopper, Chipper Chute or Discharge Opening when the machine is running.
7. Only allow responsible adults, who are familiar with the instructions, to operate the unit. Keep children away from the equipment, especially while it is operating.
8. Be sure the area is clear of other people before operating. Stop the unit if anyone enters the area.
9. Always maintain secure footing and solid balance while starting or operating the chipper shredder. Never lean directly over the machine.
10. Operate the machine only in daylight or good artificial light.
11. Do not operate the unit while under the influence of alcohol or drugs.
12. Always wear eye and hearing protection when operating this unit.
13. Keep in mind the operator is responsible for accidents occurring to other people or property.
14. Never operate the machine without proper guards, plates, or other safety protective devices in place.
15. Thoroughly inspect where equipment is to be used and remove all foreign objects.
16. Exercise extreme caution when operating on or crossing gravel drives, walks or roads. Stay alert for hidden hazards or traffic.

PRODUCT SPECIFIC SAFETY

⚠ DANGER

The chipper shredder has spinning blades that can amputate hands and feet. Do not place hands or feet in the hopper or chipper cone, or discharge chute.

⚠ WARNING

This unit discharges debris at high speeds. Always wear protective goggles and do not operate without the debris bag in place.

Do not allow anyone in the area while the unit is running. If someone does enter the area, shut the unit off immediately until they leave. Organize the work area prior to starting work.

1. Do not operate without the debris bag in place because this unit discharges debris at high speeds. If the unit is operated on hard ground, asphalt, concrete, or other hard surfaces without the collection bag in place. Material can ricochet off of the hard surface and cause an unsafe condition for users and bystanders.
2. Never leave the machine running unattended. Always turn off the engine, wait for the rotor to come to a complete stop, and disconnect the spark plug before leaving the area. Always move the unit to a safe storage area when not in use.
3. Never direct discharge material toward anyone. Avoid discharging material against a wall or obstruction. Material may ricochet back toward the operator.
4. Always stand to the side of the chipper cone when feeding tree limbs and branches into the unit, as tree limbs, branches, and harder woods may kick back while being chipped.
5. Always keep hands out of the chipper cone and shredder hopper when feeding materials. Never wrap fingers tightly around branches as you are feeding them into the unit, as a sudden inward surge could pull your hands and arms into the unit.
6. Never allow material to build up in the discharge area or shredding chamber, as this may cause new material being fed into the machine to kickback with sufficient force to injure you or other bystanders.
7. Never allow material to build up around the engine during chipper shredder operation. This could result in a fire, or overheating of the engine.

8. Never attempt to reposition or move the chipper shredder unit while it is running. Doing so could cause the machine to tip over, and reaching to steady the unit could result in accidental insertion of your hands into the chipper cone or shredder hopper areas.
9. Never continue to operate the machine if it starts making unusual noise or vibration. Shut the engine off immediately, allow the rotor to stop, disconnect the spark plug wire and secure the wire away from the spark plug. Inspect the unit for any signs of damage or foreign material in the chipping or shredding areas. Remove any solid material that may be preventing the unit from operating properly.
10. Never attempt to clear clogs from the chipper cone, shredder hopper or discharge chute while the unit is running. Always shut the engine off, allow the rotor to come to a complete stop, and remove the spark plug wire from the spark plug before removing excess materials.
11. Never attempt to perform any maintenance, repairs, or attachment of accessories while the unit is running. Always shut the unit off, allow the rotor to come to a complete stop, and remove the spark plug wire from the spark plug before beginning these activities.
12. Always make sure that the shredding chamber, shredder hopper, and chipper cone are empty before starting the unit after it has been idle. Attempting to start the unit with material in these areas could cause the engine starting cord to stop suddenly, injuring your hand and fingers, or toppling the unit over. Vibration is generally warning sign of trouble.
13. Use only attachments and accessories approved of by the manufacturer of the machine.
14. Make sure chipper shredder is free of debris before starting the engine.
15. Never attempt to make any adjustments while the engine is running.
16. After striking a foreign object, stop the engine, remove spark plug wire, and wait for all moving parts to come to a complete stop. Thoroughly inspect the machine for any damage, repair the damage before restarting and operating the machine.

ENGINE SPECIFIC SAFETY

Before cleaning, repairing, or inspecting, shut off the engine and make certain that all moving parts have come to a complete stop. Disconnect the spark plug wire and secure the wire away from the spark plug to prevent accidental starting.

▲DANGER

1. **Engines give off carbon monoxide, an odorless, colorless, poison gas. Carbon monoxide may be present even if you do not smell or see any engine exhaust. Breathing carbon monoxide can cause nausea, fainting or death, in addition to drowsiness, dizziness and confusion. If you experience any of these symptoms, seek fresh air and medical attention immediately.**
2. **If your machine comes with a separate engine manual, be sure to read and follow all safety and warning precautions outlined there, in addition to any in this manual.**

Handle fuel with care; it is highly flammable.

- a. Use an approved fuel container.
- b. Never add fuel to a running engine or hot engine.
- c. Fill fuel tank outdoors with extreme care. Never fill fuel tank indoors.
- d. Replace gasoline cap securely and clean up spilled fuel before restarting.

Preventing Carbon Monoxide Poisoning

1. Always start and run engine outdoors. Do not start or run engine in an enclosed area, even if doors or windows are open.
2. Never try to ventilate engine exhaust indoors. Carbon monoxide can reach dangerous levels very quickly.
3. Never run engine outdoors where exhaust fumes may be pulled into a building.
4. Never run engine outdoors in a poorly ventilated area where the exhaust fumes may be trapped and not easily taken away. (Examples include: in a large hole or areas where hills surround your working area.)
5. Never run engine in an enclosed or partially enclosed area. (Examples include: buildings that are enclosed on one or more sides, under tents, car ports or basements.)
6. Always run the engine with the exhaust and muffler pointed in the direction away from the operator.
7. Never point the exhaust muffler towards anyone. People should always be many feet away from the operation of the engine and its attachments.
8. Do not change the engine governor settings or over-speed the engine.
9. Do not operate the engine in a confined space where dangerous carbon monoxide fumes can collect.

Gasoline Fires and Handling Fuel Safely

Use extra care in handling gasoline and other fuels. They are flammable and vapors are explosive.

1. When storing extra fuel be sure that it is in an appropriate container and away from any fire hazards.
2. Prevent fire and explosion caused by static electric discharge. Use only nonmetal, portable fuel containers approved by the Underwriter's Laboratory (U.L.) or the American Society for Testing & Materials.
3. Always fill fuel tank outside in a well ventilated area. Never fill your fuel tank with fuel indoors. (Examples include: basement, garage, barn, shed, house, porch, etc.) Never fill tank near appliances with pilot lights, heaters, or other ignition sources. If the fuel has to be drained, this should be done outdoors. The drained fuel should be stored in a container specifically designed for fuel storage or it should be disposed of carefully.
4. Never remove the fuel cap or add fuel with the engine running. Stop engine and allow to cool before filling.
5. Do not smoke while refueling or operating engine.
6. Never drain fuel from the engine in an enclosed area.
7. Always wipe up excess (spilled) fuel from engine before starting. Clean up spilled fuel immediately. If fuel is spilled, do not start the engine but move machine and fuel container from area. Clean up spilled fuel and allow to evaporate and dry after wiping and before starting.
8. Allow fuel fumes/vapors to escape from the area before starting engine.
9. Test the fuel cap for proper installation before starting and using engine.
10. Always run the engine with fuel cap properly installed on the engine.
11. During storage, keep machine so gas cap is up.
12. Never siphon fuel by mouth to drain fuel tank.
13. Always have an adult fill the fuel tank and never allow children to fill the engine.
14. Never allow an adult or anyone under the influence of drugs or alcohol to fill engine.
15. When storing gasoline or equipment with fuel in the tank, store away from furnaces, stoves, water heaters or other appliances that have a pilot light or other ignition source because they can ignite gasoline vapors.
16. Never fill containers inside a vehicle or on a truck bed with a plastic bed liner. Always place containers on the ground away from your vehicle before filling.
17. Remove gas-powered equipment from the truck or trailer and refuel it on the ground. If this is not possible, then refuel such equipment on a trailer with a portable container, rather than from a gasoline dispenser nozzle.

Burns and Fires

The muffler, muffler guard and other parts of the engine become extremely hot during the operation of the engine. These parts remain extremely hot after the engine has stopped.

Prevention of Burns and Fires

1. Never remove the muffler guard from the engine.
2. Never touch the muffler guard because it is extremely hot and will cause severe burns.
3. Never touch parts of the engine that become hot after operation.
4. Always keep materials and debris away from muffler guard and other hot parts of the engine to avoid fires.

Children and Bystanders

Tragic accidents can occur if the operator is not alert to the presence of children and/or bystanders. Never assume that others will remain where you last saw them.

1. Keep the area of operation clear of all persons, especially small children and pets. Keep children under the watchful care of a responsible adult.
2. Be alert and turn the machine off if children enter the area.
3. Before and while moving backwards, look behind and down for small children.
4. Never allow children to operate the machine.

ASSEMBLY

Install Stand (See Figure 1)

1. Position the stand (A) underneath the engine base.
2. Using the four M8x60 bolts (C) and four nuts (D) to tight the stand with the engine base plate.

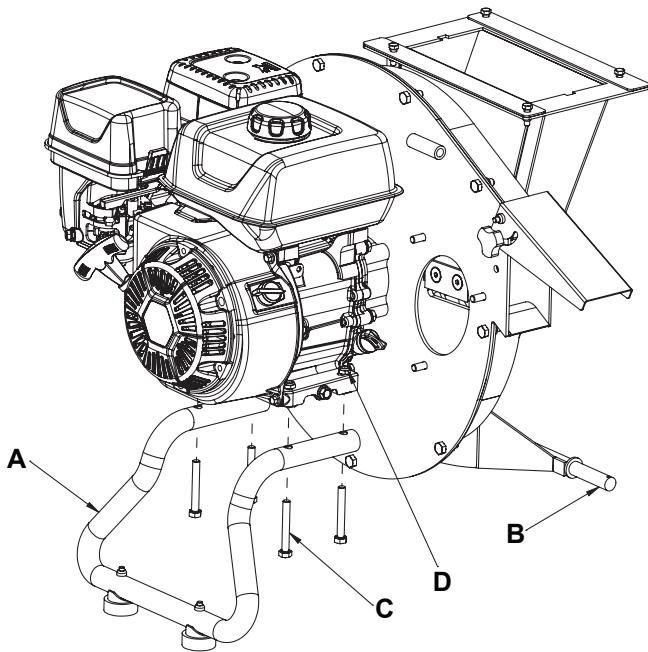

Figure 1

Install the Wheels (See Figure 2)

1. Put the wheel onto the axle(B), Make sure the wheel disc flat side face to machine.
2. Slide the washer (A) onto the axle against the wheel.
3. Insert the cotter pin (C) into the hole to secure the wheel on the axle.

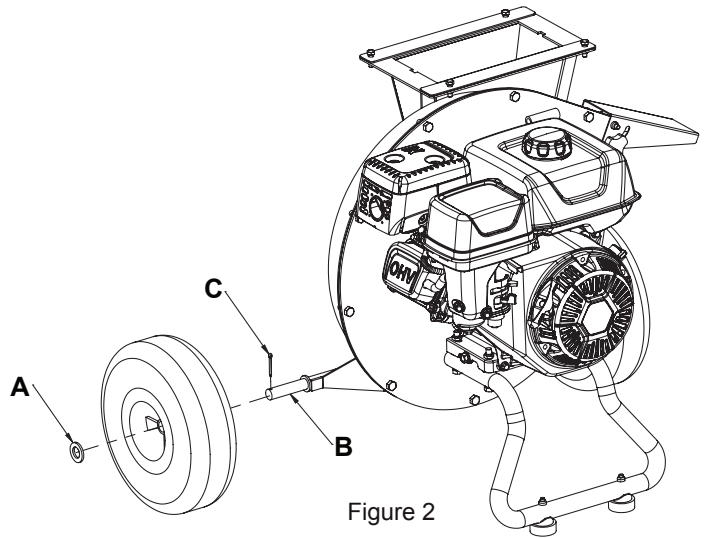

Figure 2

Install Chipper Cone (See Figure 3)

1. Position the chipper cone(B) over the three M8 thread studs protruding from the engine plate.
2. Attach the three M8 flange nuts (C) and tighten to secure the cone.
3. Rubber cone cover (A) can be used when using the vacuum function.

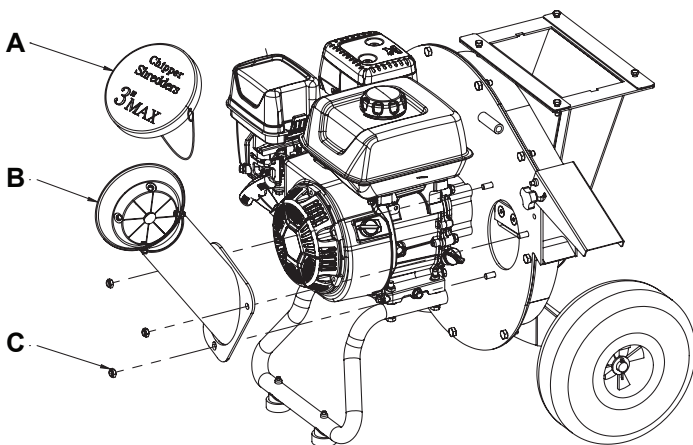

Figure 3

Install the Handle (See Figure 4)

1. Position the handle(A) to by aligning the handle holes with the hopper holes on two sides.
2. Using four flange bolts (C) and nuts (D) to secure the handle on the hopper.

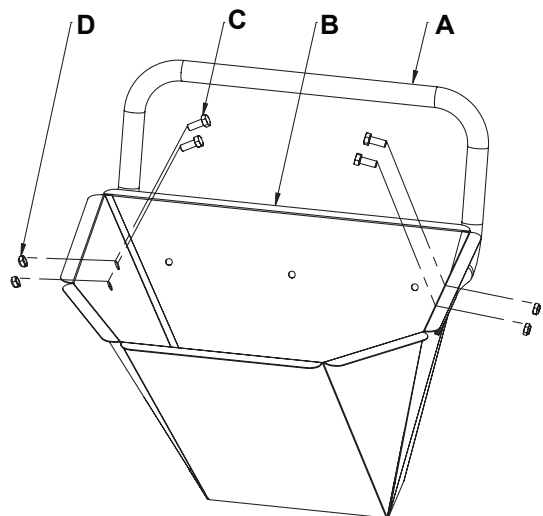
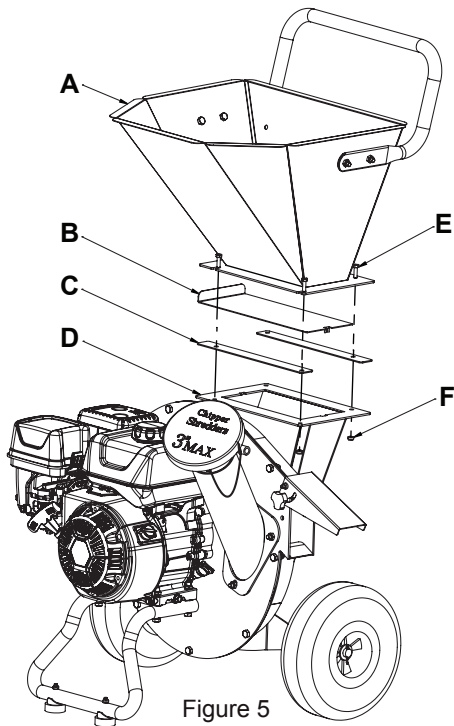

Figure 4

Install the Hopper (See Figure 5)

1. Assemble the plate (C) and put on plate (B).
2. Position the hopper (A) by aligning the assembly holes and fix by bolts (E).
3. Tight nuts (F) to secure the guard assembly to the hopper.



Install the Hopper Guard (See Figure 6)

1. Position the hopper guard assembly (C) by aligning the assembly holes with the holes in the hopper
2. Using the three M6 flange bolts (A) and nuts (D) to secure the guard assembly (C) to the hopper.

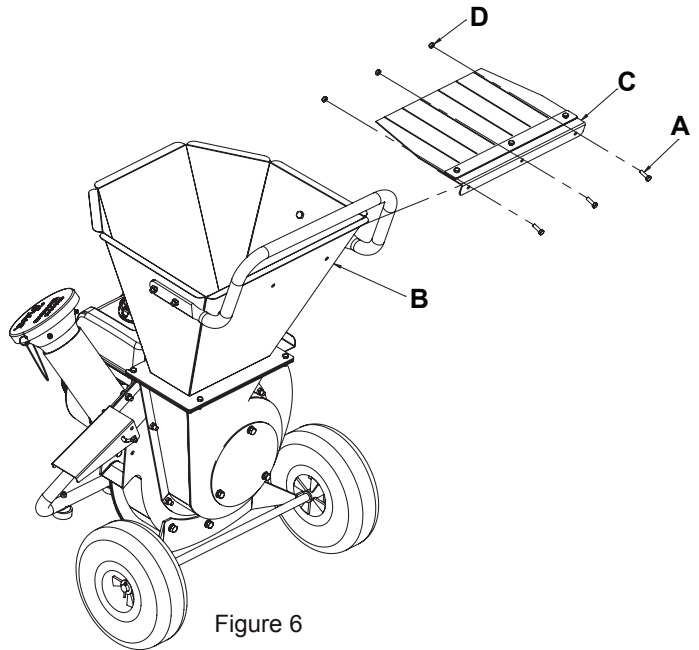

BAG ASSEMBLY (See Figure 7)

1. Open the dam-board of discharge chute, locking bag with triangle handle (A).
2. Connect the rod (B) to the shaft sleeve (C), and fix it with two B-pins (D).
3. Put on the bag (E) to the rod (B).
4. Fix bag to the discharge chute with two star shape handle (F) which go through bag loops.
5. Finally fix the bag to the chipper body with digging rope.

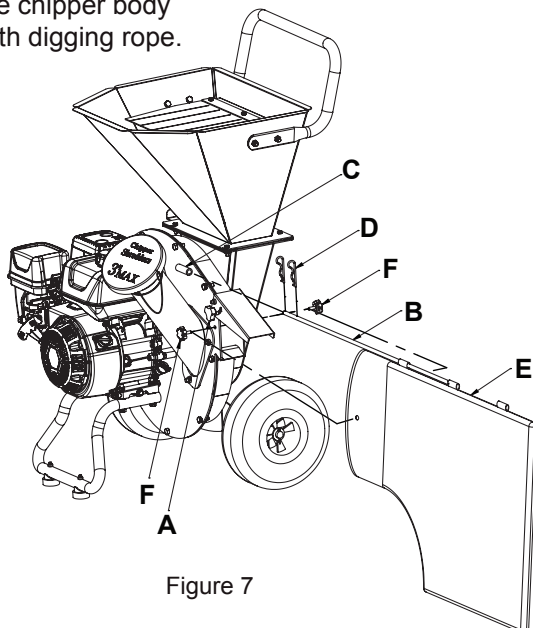

Adding Oil (See Figure 8)

You must add oil to the machine before starting, oil can be added in either of the two spots located at the bottom rear of the machine there is one each side. (See page 1 for oil type)

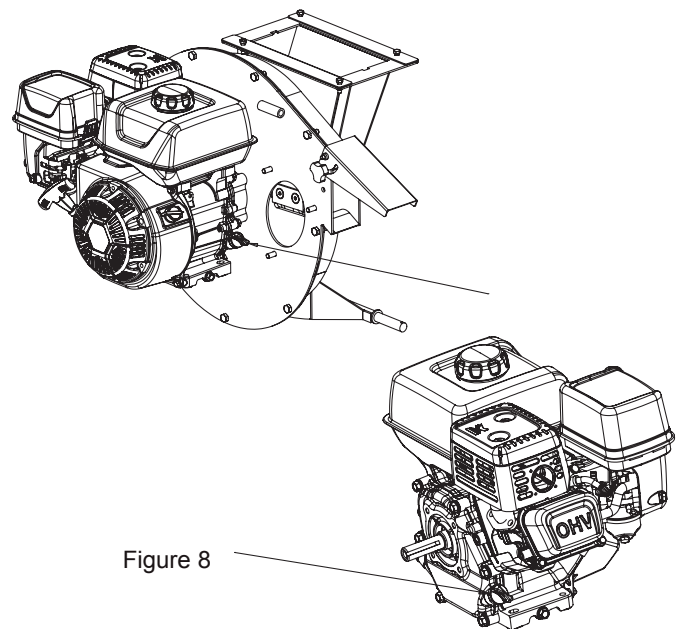

⚠ DANGER

1. The exhaust from this product contains carbon monoxide gas. Carbon monoxide is a colorless, odorless and tasteless gas that can cause dizziness, nausea, unconsciousness or even brain damage and death if inhaled for prolonged periods.
2. Operate the unit outdoors in a well-ventilated location only. Keep children, pets and bystanders away.
3. Failure to follow these instructions may result in serious injury or death.

⚠ WARNING

1. Gasoline is highly flammable and must be handled with care. Never fill the tank when the engine is still hot from recent operation.
2. Do not allow open flame, smoking or matches in the area. Avoid over-filling and wipe up any spills.

⚠ WARNING

To avoid serious personal injury from rotating cutting blades, keep hands out of inlet while machine is running.

Do Not Use Gasoline Containing Methanol, Gasohol Containing More Than 10% Ethanol, Gasoline Additives Or White Gas Because Engine/fuel System Damage Could Result.

⚠ IMPORTANT

Engine is shipped from factory without oil. You must add engine oil Before starting engine.

Adding Fuel

To add fuel:

1. Remove the fuel cap.
2. Fill the tank. Do not overfill. Leave room in the tank for fuel expansion. Refer to your engine manual for specific fuel recommendations.
3. Install and hand tighten the fuel cap.

Starting the Engine

1. See engine manual for starting up instructions.
2. Ensure engine is running full throttle before beginning chipping operation. On some engines, the throttle may not be adjustable.

Stopping the Engine

1. See engine manual for shut down procedure.
2. Stopping the engine is the only way to stop the rotor from turning. With engines equipped with an adjustable throttle, move the throttle to the SLOW position and wait for engine to be running a slow RPM. Then switch to STOP ENGINE as shown in the engine manual.

TRANSPORTING AND STORAGE

1. Always observe safe refueling and fuel handling practices when refueling the unit after transportation or storage.
2. Never store the unit (with fuel) in an enclosed poorly ventilated structure. Fuel vapors can travel to an ignition source (such as a furnace, water heater, etc.) and cause an explosion. Fuel vapor is also toxic to humans and animals.
3. Always use the hopper handle and built-in wheels to move the chipper shredder. Never lift the unit using the fuel tank for support. If the unit must be lifted, always use at least two people, and always grip the unit securely using the front leg and hopper handle.
4. Always follow the engine manual instructions for storage preparations before storing the unit for both short and long term periods.
5. Always follow the engine manual instructions for proper start-up procedures when returning the unit to service.
6. Never store the unit or fuel container inside where there is an open flame or pilot light, such as in a water heater. Allow unit to cool before storing.

Storage

Perform engine maintenance and storage measures listed in the engine owner's manual. This includes draining the fuel system, or adding stabilizer to the fuel. **NOTE: Do not store a fueled unit in an enclosed structure. (SEE GASOLINE FIRES AND HANDLING FUEL SAFETY)**

Before starting the unit after it has been stored:

1. Check all fluid levels. Check all maintenance items.
2. Perform all recommended checks and procedures found in the engine owner's manual.
3. Allow the engine to warm up for several minutes before use.

MAINTENANCE

Schedule & Procedures

The following schedule should be followed for normal care of your unit.

SAFETY ITEMS	BEFORE EACH USE	EVERY 5 HOURS	EVERY 25 HOURS	EVERY 100 HOURS	EVERY 250 HOURS	SPRING & FALL
Check for loose hardware		X				X
Check all safety labels						X
Inspect cone, hopper, and guards	X					X
CHIPPER MAINTENANCE ITEMS						
Clean debris from engine and chipper	X					
Inspect/Rotate Shredding Hammers			X			
Inspect/Rotate Chipping Knives			X			

Engine Maintenance

Refer to the engine manual included in your package for information on engine maintenance. Your engine manual provides information and a maintenance schedule for performing the following tasks:

1. Always check oil level before starting engine. Refer to engine manual for capacity and type of oil to use.
2. Change oil after first 5-8 hours of operation. Change oil while engine is warm. Refill with new oil of recommended grade.
3. Check spark plug yearly or every 50 hours of operation.
4. Service air cleaner.
5. Keep engine and parts clean.
6. Check engine and equipment often for loose nuts and bolts, keep these items tightened.

Check for Loose Hardware

1. Service Interval: Every 5 hours; every spring and fall.
2. Inspect the unit, checking for loose hardware or components.
3. Pay special attention to the hardware attaching the chipper cone, hopper, axle, and front leg.

Check Safety Labels

1. Service Interval: Every spring and fall.
2. Check that the safety labels are in place and undamaged.
3. Sample illustrations and part numbers of the decals can be found on page 6. Replace any damaged or missing decals.

Inspect Cone, Hopper, & Guards

1. Service Interval: Every spring and fall.
2. Check that the chipper cone, shredder hopper, and discharge guards are in place, undamaged, and secure.
Replace any damaged or missing parts.

Clean Debris from Engine & Chipper

1. Service Interval: Before each use and every 100 hours.
2. The engine requires air flow to cool itself and for combustion.
3. Before each use, clean any debris from the unit especially from around the air shroud intake, air filter, and muffler. Every 100 hours, remove the engine air shroud and clean out any debris from the engine cooling fins.
We recommend having this service performed by an authorized dealer.

Inspect / Rotate Shredding Hammers (See Figure 9)

Service Interval: Every 25 Hours, or As Necessary

The shredding hammers of this unit can be rotated to provide a new cutting surface as required. The Y hammers can be flipped over once. To inspect the shredding hammers:

1. Disconnect the spark plug wire and secure it away from the spark plug.
2. Remove the small circular access panel (B) from the back of the shredder housing. SEE FIGURE 9
3. Inspect the cutting edges of the Y-hammers (A).

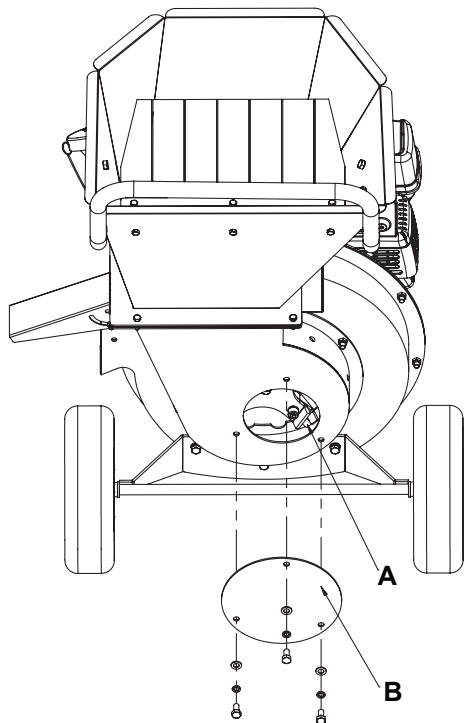

Figure 9

Inspect Chipping Knives (See Figure 10)

Service Interval: Every 25 hours, or as necessary the chipping knives of this unit can be rotated or sharpened to provide a new cutting surface as required. When inspecting the knives be careful to avoid touching the sharpened edges. To inspect the chipping knives:

1. Disconnect the spark plug wire and secure it away from the spark plug.
2. Remove the nuts securing the chipper cone to the front of the chipper. Remove the chipper cone to access the knives. SEE Figure 10
3. Using the recoil starter, slowly pull the starter rope to rotate the rotor into position so the blades can be seen. To sharpen or replace the chipper knives, see the Troubleshooting and Repair section.

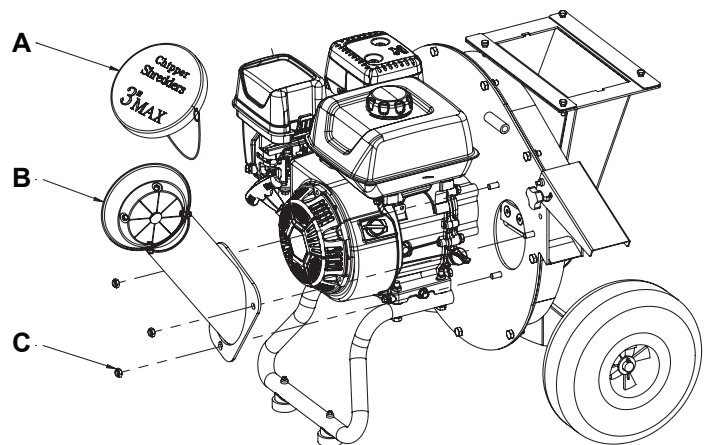

Figure 10

▲ IMPORTANT

Engine is shipped from factory without oil. You must add engine oil before starting engine.

▲ CAUTION

1. For the safety of the user, and to maximize the life of the engine, it is crucial to take time to check the condition of the engine.
2. Problems must be corrected before operating.
3. Avoid injury! Engine oil is hazardous to your health. Dispose of oil appropriately.
4. Use a safe disposal/recycling center.

TROUBLESHOOTING CHART

1. While normal care and regular maintenance will extend the life of your equipment, prolonged or constant use may eventually require that service be performed to allow it to continue operating properly.
2. The troubleshooting guide below lists the most common problems, their causes, and remedies.
3. See the information on the following pages for instructions on how to perform most of these minor adjustments and service repairs yourself. If you prefer, all of these procedures can be performed for you by your local authorized dealer.

⚠️ WARNING

1. To avoid serious injury, perform maintenance on the unit only when the engine is stopped.
2. Always disconnect the spark plug wire and fasten it away from the plug before beginning the maintenance, to prevent accidental starting of the engine.

Problem(s)	Possible Cause	Corrective Action
Engine won't start	<ol style="list-style-type: none"> 1. No fuel. 2. Choke not in START position. 3. Low quality or deteriorated, old gasoline. 4. Dirty fuel passageways. 5. Spark plug cap not connected securely. 6. Spark plug fouled. 7. No compressions. Problem after long storage periods. 8. Low engine oil. 	<ol style="list-style-type: none"> 1. Add fuel. 2. Turn choke to START position. 3. Use fresh unleaded gasoline. 4. Clean out passageways using fuel additive. Heavy deposits may require further cleaning. 5. Connect spark plug cap properly. 6. Remove spark plug. Clean/replace as recommended in engine manual. 7. Lubricate the cylinder, pour tablespoon of oil into spark plug hole. Crank engine a few times and try to start again. 8. Add engine oil to proper level.
Engine exhaust is black	<ol style="list-style-type: none"> 1. Dirty air filter. 2. Choke closed. 	<ol style="list-style-type: none"> 1. Replace air filter. 2. Open choke.
Engine stops suddenly	<ol style="list-style-type: none"> 1. Fuel tank empty or full of impure or low quality gasoline. 2. Low oil shutdown. 3. Disconnected or improperly connected spark plug cap. 4. The limb is too long. 	<ol style="list-style-type: none"> 1. Add fuel tank with fresh unleaded gasoline. 2. Fill engine oil to proper level. 3. Secure spark plug cap. 4. If the limb diameter for the side chute in 2"-3" and the length over 31" long, suggest the operator should help the limb feeding by slightly holding to keep the rotate speed.
Engine runs but no material is discharged	<ol style="list-style-type: none"> 1. Discharge chute clogged. 2. Engine not running at full speed. 	<ol style="list-style-type: none"> 1. Clean out debris. 2. Set throttle control to FAST if equipped.
Chipping action slow, or engine stalling	<ol style="list-style-type: none"> 1. Branch diameter is too thick. 2. Throttle set is too slow. 3. Tree limbs are extremely hard or dried out. 	<ol style="list-style-type: none"> 1. Do not process branches over 3" diameter. 2. Adjust throttle to increase engine speed. 3. Material is not suitable for chipping.
Unusual noise or vibration when chipping material	<ol style="list-style-type: none"> 1. Rotor overloaded with material. 2. Hammers are broken, bent, or loose. 3. Hammers frozen in place. 	<ol style="list-style-type: none"> 1. Allow unit to clear itself before adding more material to the hopper. 2. Check assembly. Tighten or replace as necessary. 3. Check for obstructions and debris. Repair or replace as necessary.
Vacuum not working.	<ol style="list-style-type: none"> 1. Hopper gate not closed. 2. Cone cover not installed. 3. Hose not attached properly. 4. Engine not running at full RPM. 	<ol style="list-style-type: none"> 1. Slide gate to closed position. 2. Allow material to dry. 3. Clear blockage or replace. 4. Set throttle control to FAST if equipped.

REPAIR

Shredding Hammer Rotation and Replacement

The cutting edges of the shredding hammers may eventually wear out requiring rotation of the hammer or replacement if all cutting edges have been dulled.

To rotate the shredding hammers:

1. Turn the engine off and wait for all moving parts to stop.
2. Disconnect the spark plug wire and secure it away from the spark plug.
3. Detach the rotor housing and hopper from the rotor plate. SEE FIGURE 9
4. Note the assembly sequence of the hardware used to secure the hammers. Using an allen wrench remove the socket head cap screw (A) and related hardware. SEE FIGURE 10
5. Inspect the hammers (D), spacer tubes (C, E), and hardware. If the spacer tube (E) shows signs of wear, replace it. Inspect and flip, or replace the hammers (D).
6. Reassemble the hammers, spacers, washers, and cap screws. Torque the socket head cap screws (A) back tightly
7. Repeat for all the hammers.

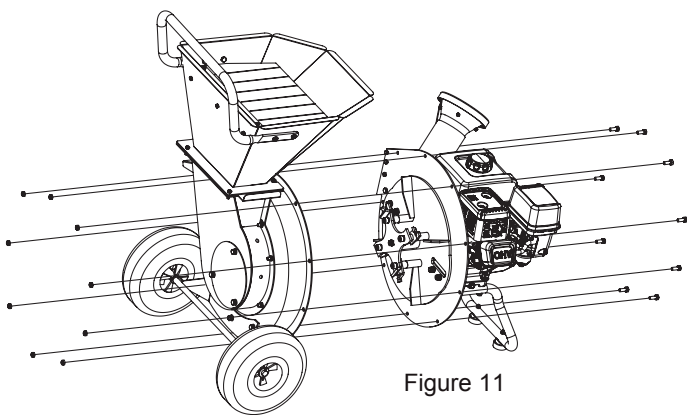

Figure 11

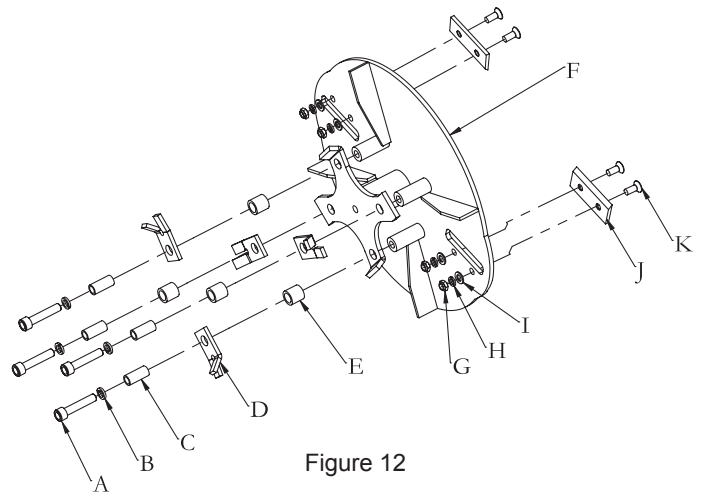

Figure 12

Chipping Knives Sharpening and Replacement

1. The chipping knives should be sharpened or replaced when tree limbs require extra force to feed into the chipper cone.
2. The chipping knives may be sharpened at a 39-degree angle until the distance between the edge of the blade bevel and the mounting hole is less than 1/16" (1.6mm). See Figure 13.

To inspect, sharpen, or replace the chipping knives:

1. Turn the engine off and wait for all moving parts to stop.
2. Disconnect the spark plug wire and secure it away from the spark plug.
3. Detach the rotor housing and hopper from the rotor plate. See Figure 11.
4. Remove the rotor by removing the hardware that secures it to the engine crank shaft. See Figure 12. NOTE: Do not lose spacer. During reassembly Be sure to place spacer is installed inside rotor. Without spacer, rotor will interfere with housing components.
5. Using a hex wrench, remove the two socket head cap screws and the chipper knife. See Figure 13.
6. Inspect, rotate, sharpen, or replace the chipper knife. See Figure 13.
7. Reinstall the chipper knife and tighten the socket head cap screws.

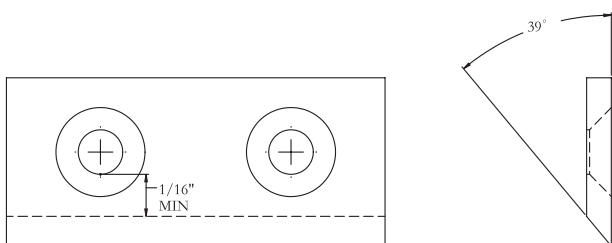

Figure 13- Chipper knife minimum cutting edge

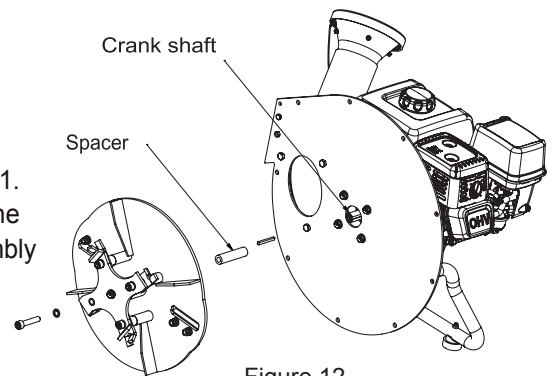

Figure 12

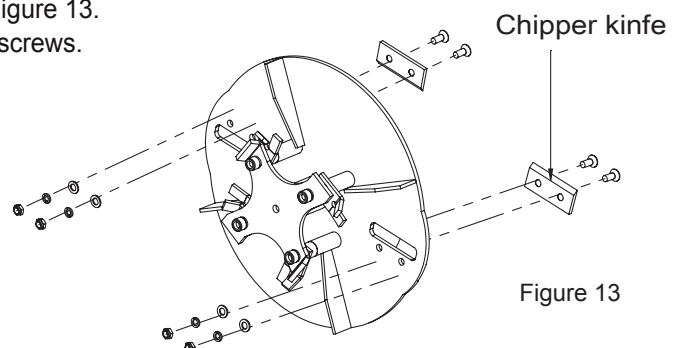
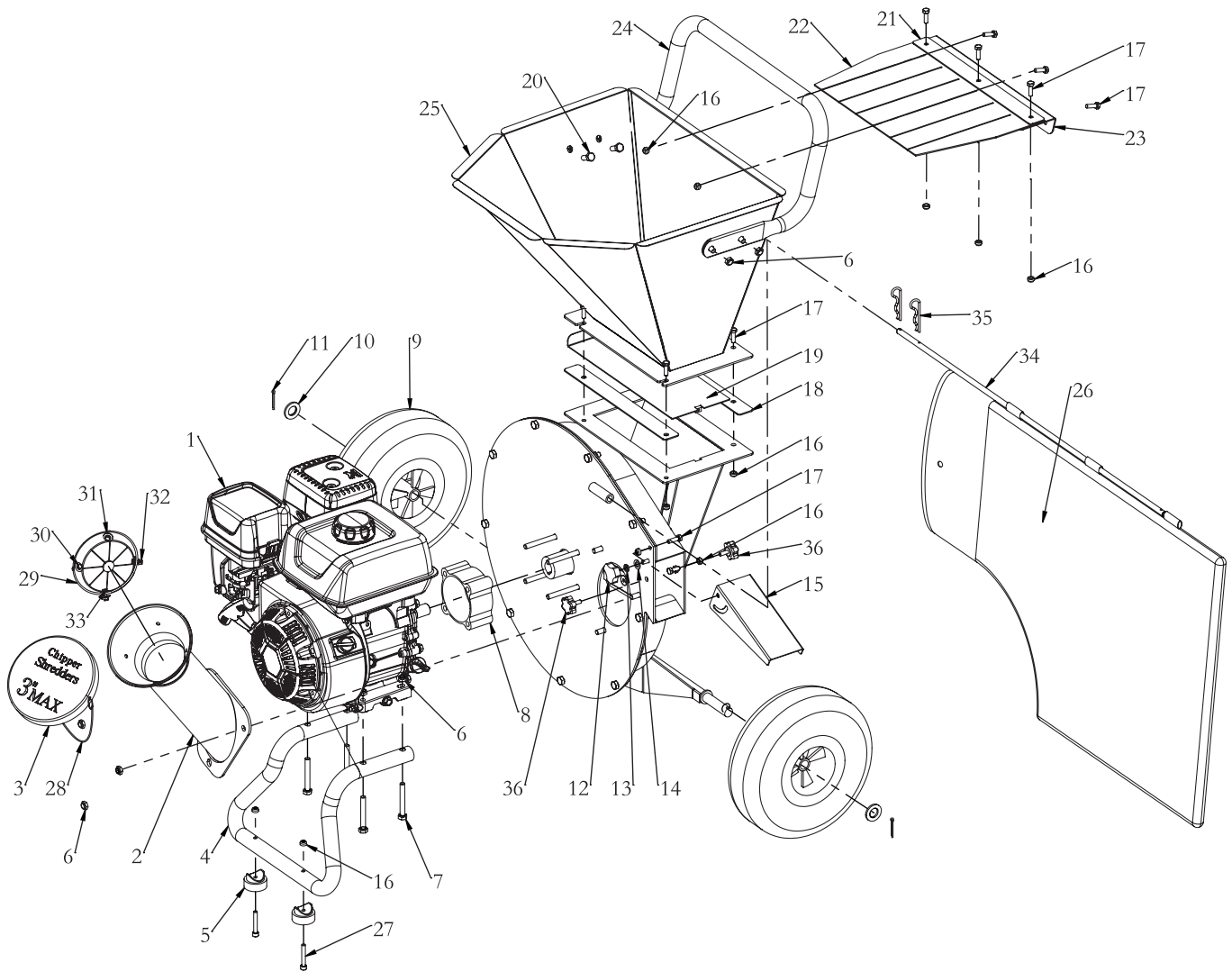

Figure 13

PARTS BREAKDOWN



Part No.	Description	Q'ty	Part No.	Description	Q'ty
1	Engine	1	19	Damper	1
2	Chipper cone	1	20	Flange bolt M8x20	4
3	Cone cap	1	21	Retainer hopper guard	1
4	Support stand	1	22	Hopper Guard	1
5	Stand pad	2	23	Flange hopper guard	1
6	Flange nut M8	11	24	Handle	1
7	Flange bolt M8x60	4	25	Hopper	1
8	Flange	1	26	Bag	1
9	Wheel	2	27	Socket Cap Screw M6x40	2
10	Washer	2	28	Chain	1
11	Cotter pin	2	29	Rubber dam-board	1
12	Handwheel	1	30	Flange bolt M4x10	3
13	Spring washer	1	31	Big flat washer M4	5
14	Washer	1	32	Flange nut M4	4
15	Discharge guard	1	33	Flange bolt M4x15	1
16	Flange nut M6	13	34	Rod	1
17	Flange bolt M6x20	13	35	B pin	2
18	Damper attachment	2	36	Star shape handle	2

Parts Breakdown – Engine and Rotor Group

Part No.	Description	Q'ty
1	Engine	1
2	Flange	1
3	Engine plate	1
4	Engine flange bolt	4
5	Key parallel pin	1
6	Bearing spacer	1
7	Rotor assembly kit	1
8	Rotor flange bolt	1

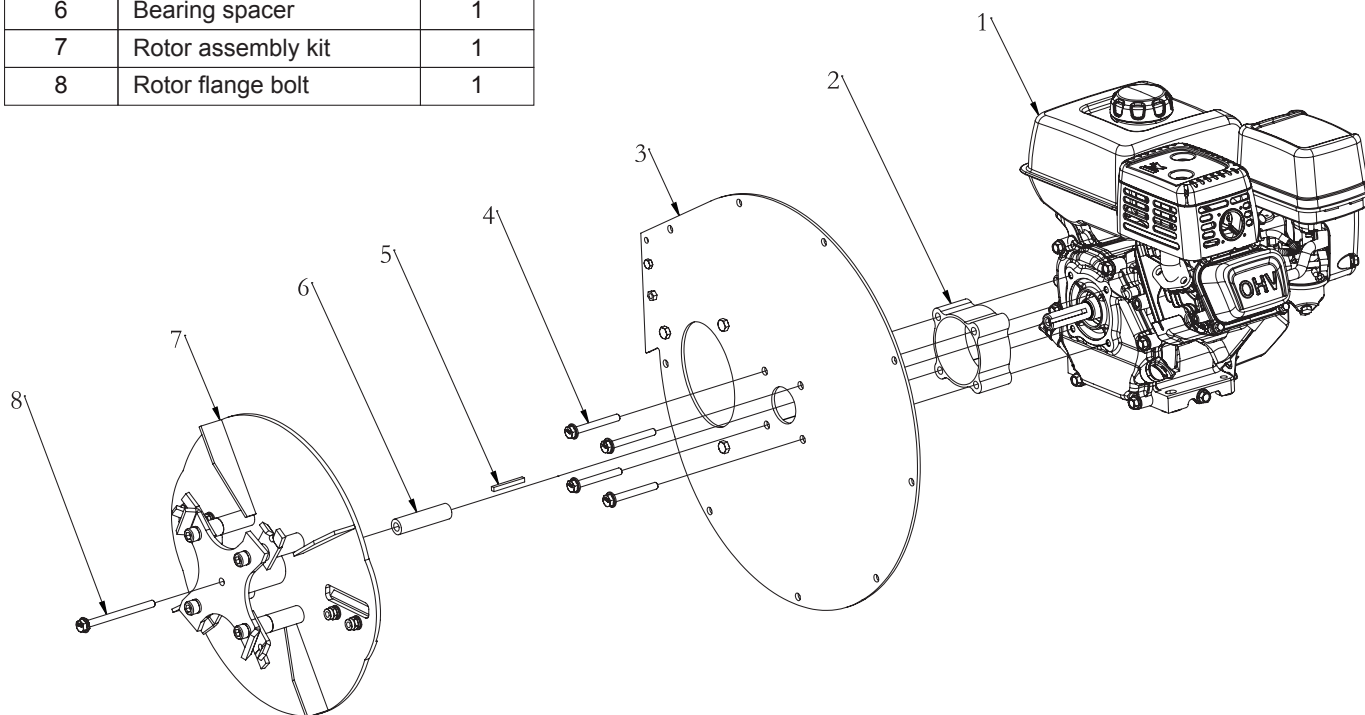

Parts Breakdown – Rotor Group

Part No.	Description	Q'ty
1	Socket head cap screw M10x50	4
2	Spring washer 10	4
3	Spacer	4
4	Y hammer	4
5	Bearing sleeve	4
6	Knives plate	1
7	Locknut M8	4
8	Spring washer 8	4
9	Washer 8	4
10	Knife	2
11	Screw	4

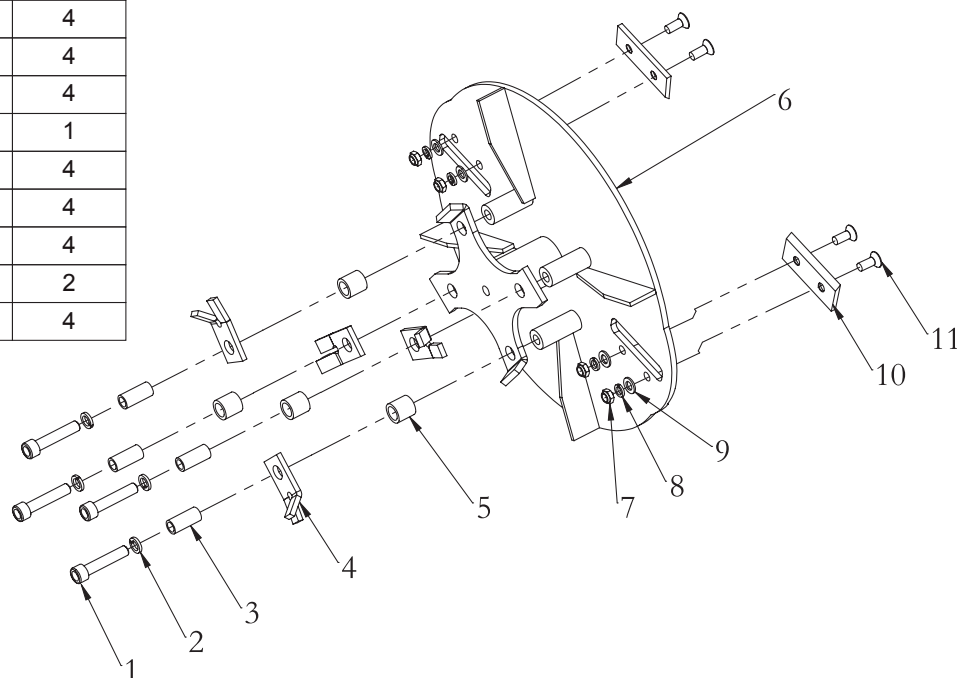

PARTS BREAKDOWN - CHIPPER HOUSING GROUP

Part No.	Description	Q'ty
1	Engine plate	1
2	Rotor assembly kit	1
3	Rotor house	1
4	Chipper back cover	1
5	Flange bolt M8x20	9
6	Flange nut M8	15
7	Vacuum inlet cover	1
8	Hex bolt M8x15	6
9	Spring washer	6
10	Washer	6
11	Wheel rack	1

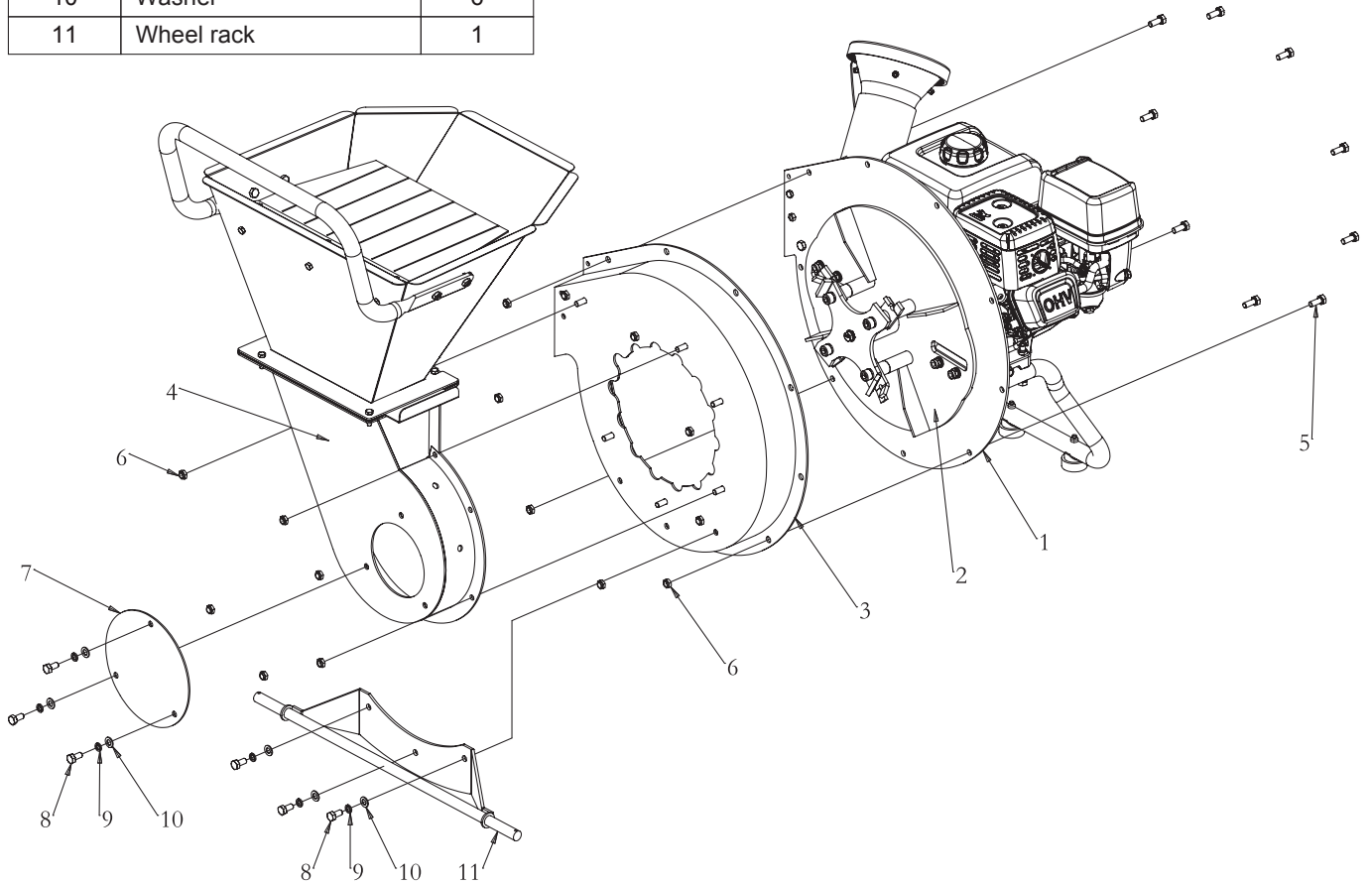

⚠️ WARNING

Limited 3 Years Warranty

1. The manufacturer warrants this chipper shredder against defects in material and craftsmanship, for a period of 36 months from date of original purchase, but not including engine mounted on the product.
2. This warranty excludes parts that are worn or damaged due to normal wear, such as bearings, wheels, tires, Y hammers, chipper knives, routine maintenance items such as O-rings, seals, and lubricants, accessory parts such as collection bag etc.
3. Manufacturer's liability is limited to replacement or repair of defective material within the warranty period, when returned freight prepaid to the distributor or their designated service depot.
4. The warranty does not cover damage caused by accident, misuse or faulty installation.
5. The chipper shredder must be installed and maintained in compliance with the instructions.

Vacuum Kit



Optional Accessory for
LCE01 Wood Chipper Shredder



Item# LC901

Specification: 4"x10' extension hose with vacuum nozzle

Type of waste permitted: Light, loose, dry waste such as leaves, grass clippings, or sawdust.

NOTES: The vacuum is engineered for small, loose waste and for cleaning around decorative landscaping and flower beds. Twigs, wet leaves, and other bulky materials will clog the hose or obstruct the shredding chamber.

TROUBLE SHOOTING:

PROBLEM	POSSIBLE CAUSE	SOLUTIONS
Vacuum not working	1. Hopper gate not closed.	1. Slide gate to closed position.
	2. Cone cover not installed.	2. Install the cone cover.
	3. Hose not attached properly.	3. Clear blockage or replace.
	4. Engine not running at full RPM.	4. Set throttle control to FAST if equipped.

PART LIST

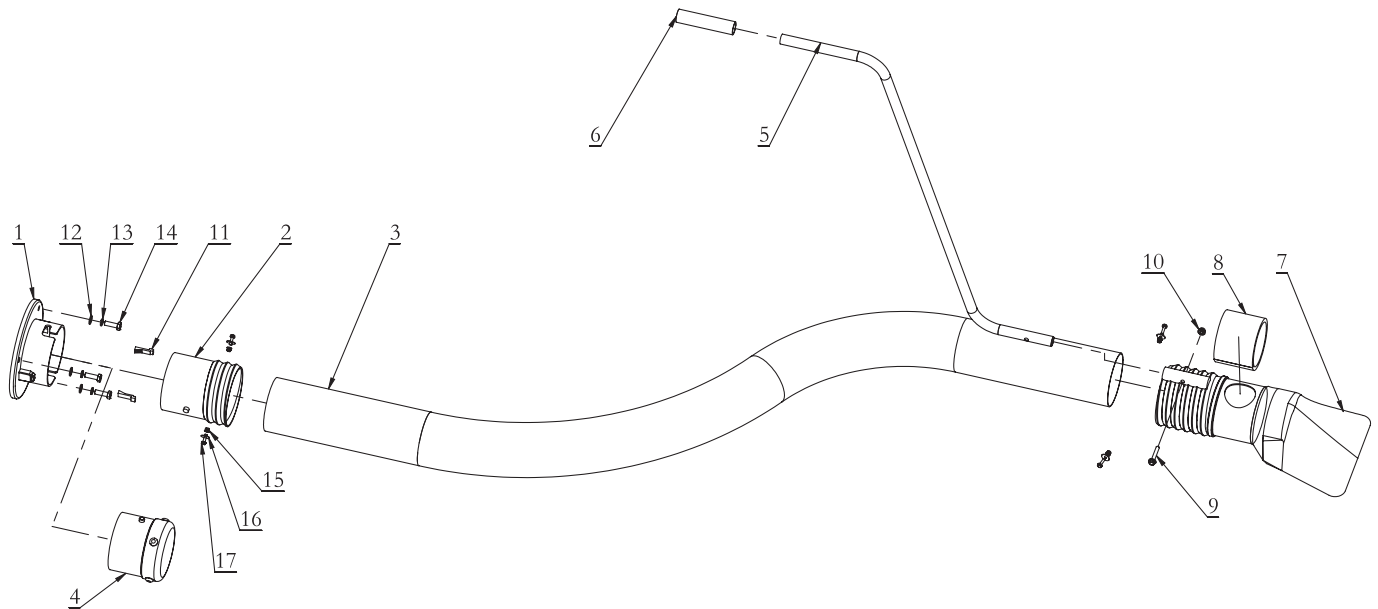

Part No.	Description	Q'ty	Part No.	Description	Q'ty
1	Adapter	1	10	M6 Locknut	1
2	Hose Adapter	1	11	Washer	2
3	Extension vacuum hose	1	12	M8 Flat washer	3
4	End cap	1	13	M8 Elastic washer	3
5	Handle	1	14	M8x25 hex head bolts	3
6	Handle grip	1	15	M4 Locknut	4
7	Vacuum nozzle	1	16	M4 Large flat washer	4
8	Plastic ring	1	17	M4*15 Hex bolt	4
9	M6*35 Hex bolt	1			



Great Circle USA
 Support Line: 1-866-493-0524
 help@greatcircleus.com
 www.greatcircleus.com