

# Electric Cooktop Cuisinière Électrique

INSTALLATION INSTRUCTION AND USER MANUAL

 **WARNING**

Please read this manual carefully before using your product, and keep it for future reference. As the appliance is kept upgrading, it may differ between the actual appliance and the one in the manual. Please refer to the actual product.

---

ENGLISH .....	11
FRANÇAIS .....	29

## Installation

**EN** Warning! Before proceeding with installation, read the safety information in the User Manual.

**FR** Attention! Veuillez lire les consignes de sécurité que contient la Notice d'utilisation avant d'installer l'appareil.

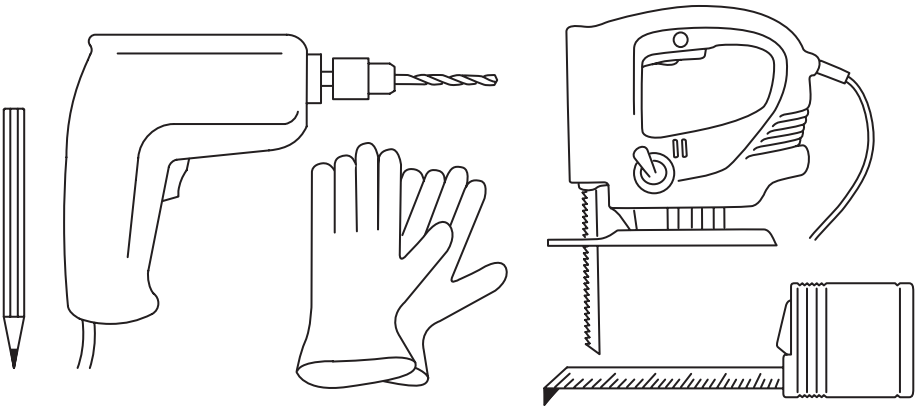

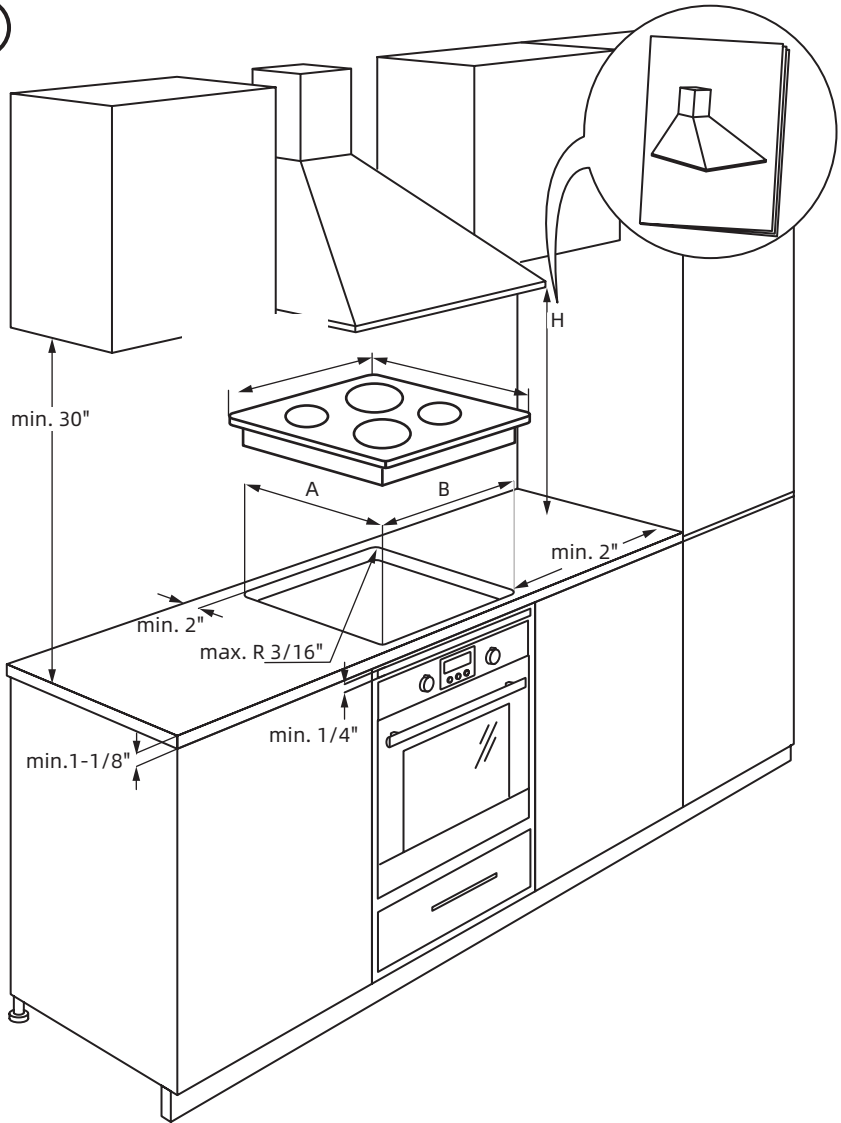

	Product Size (W × D × H)	Built-in Size (B × A)
30" Series	30-5/16" × 20-1/2" × 2-1/4" (770 × 520 × 58 mm)	29-3/16" × 19-3/8" (742 × 492 mm)
36" Series	35-7/16" × 20-1/2" × 2-1/4" (900 × 520 × 58 mm)	34-5/16" × 19-3/8" (872 × 492 mm)
12" Series	11-7/16" × 20-1/2" × 2-1/16" (290 × 520 × 52 mm)	10-9/16" × 19-11/16" (268 × 500mm)

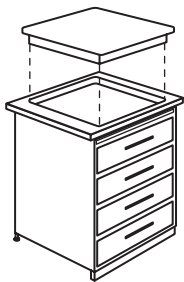
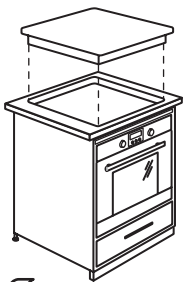

**1**

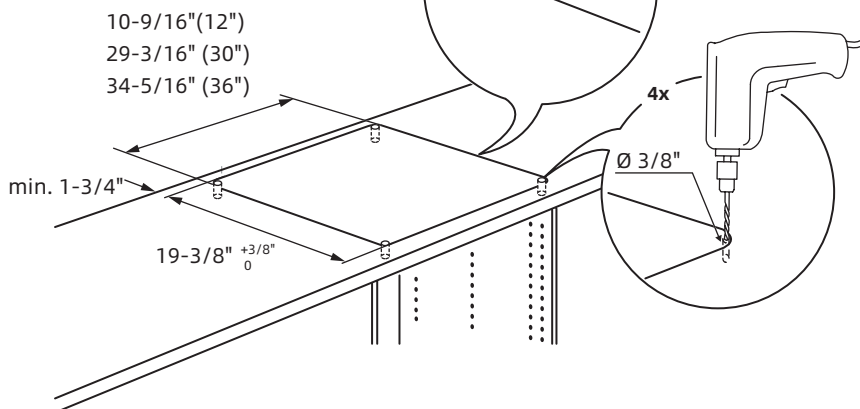

**2**

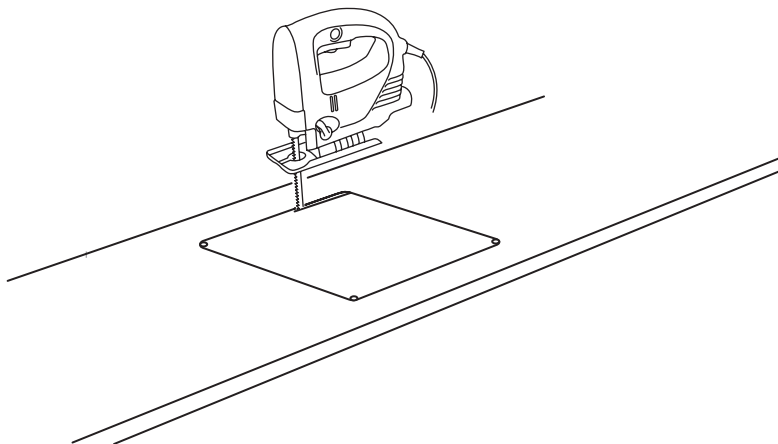

3

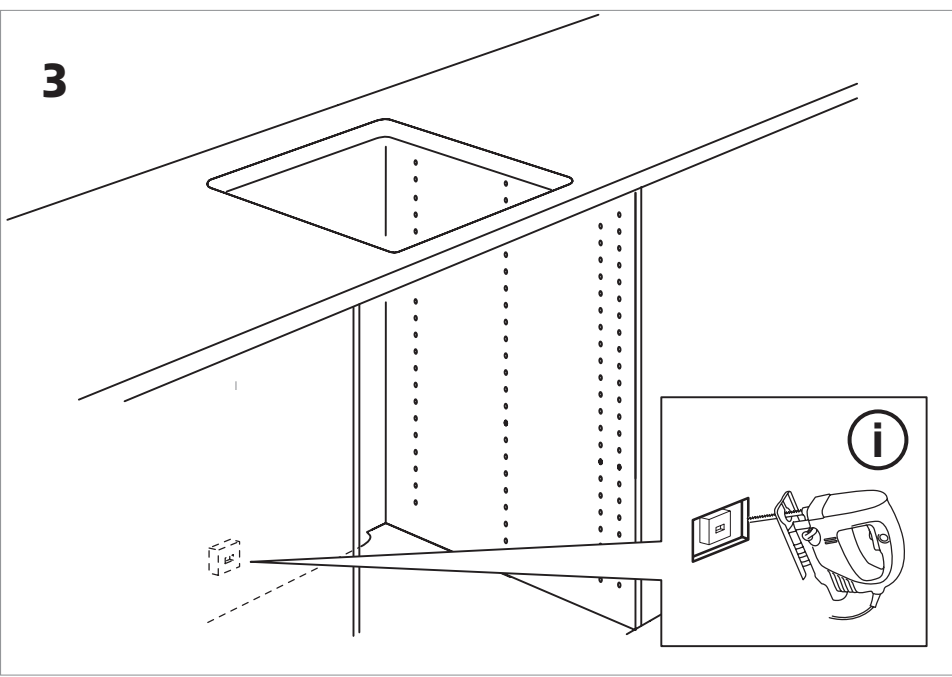

4

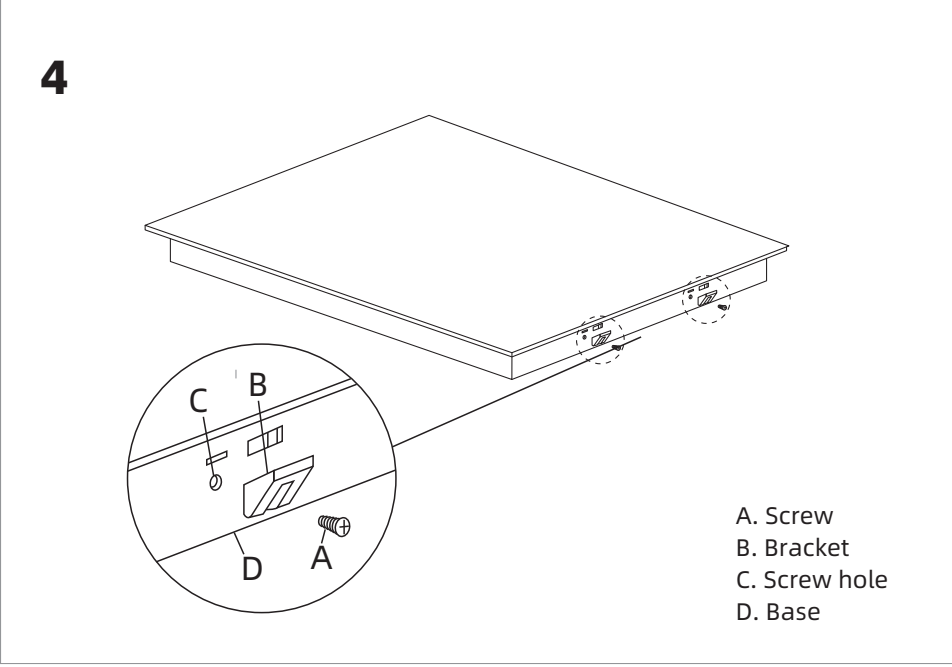

- A. Screw
- B. Bracket
- C. Screw hole
- D. Base

5

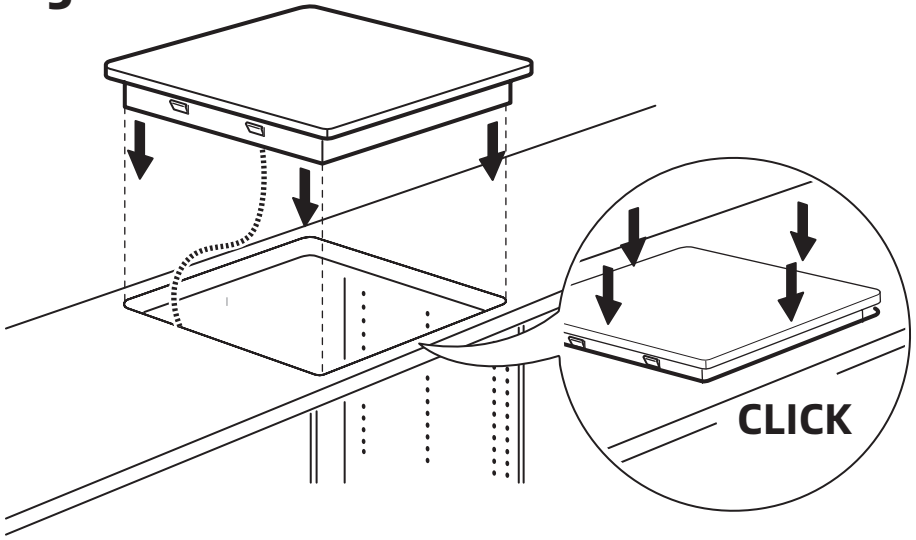

6

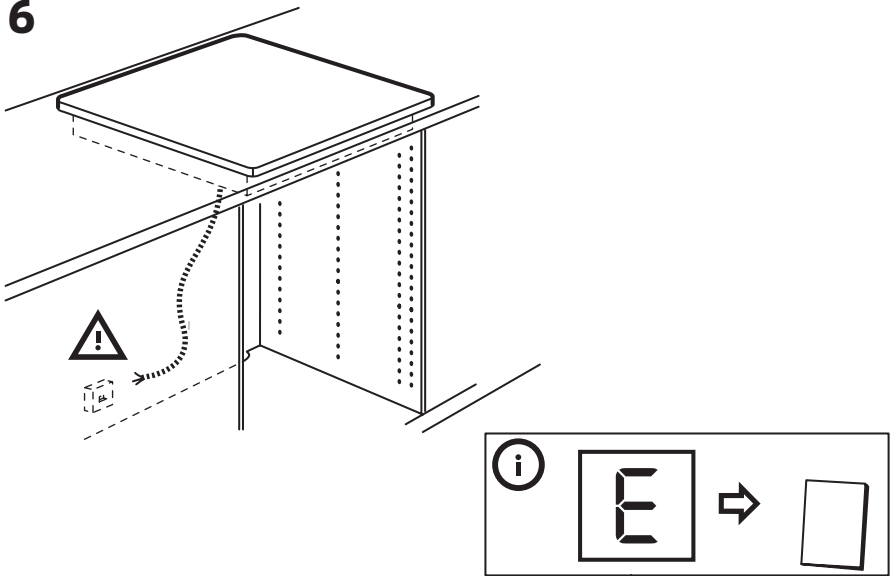

7

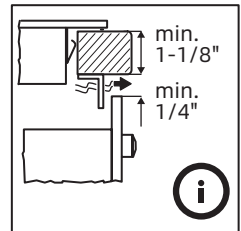
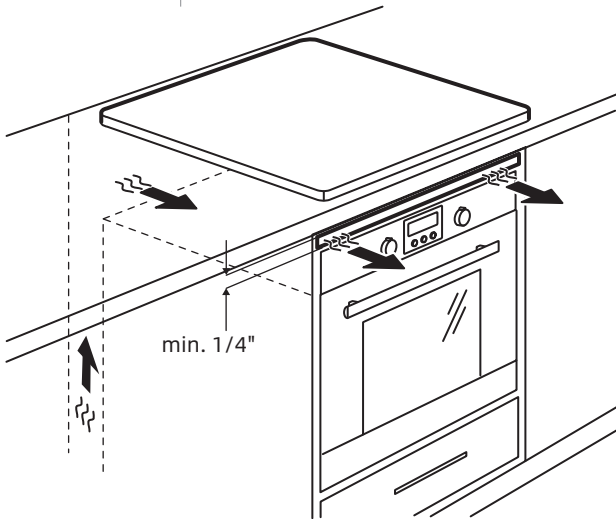
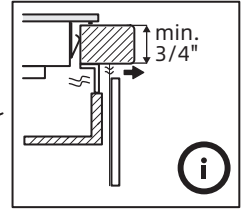
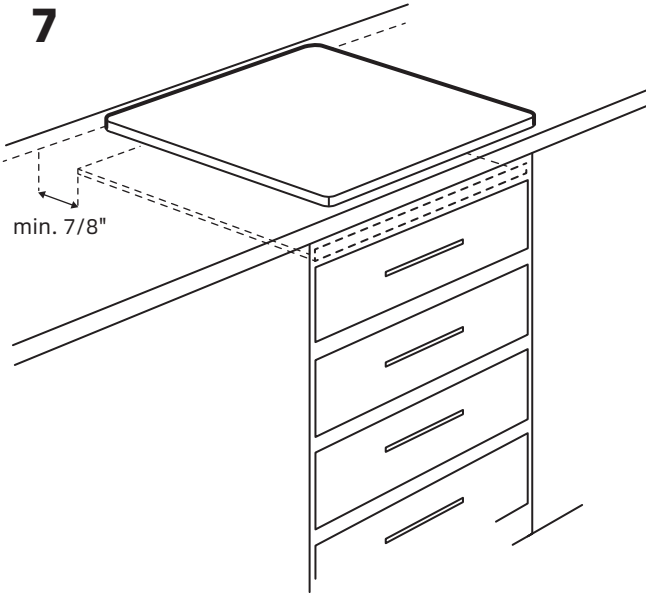

## WIRING DIAGRAM

MT-C23503C-V2  
MT-T23003RT

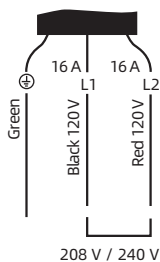

MT-C47464L8-V1.5  
MT-T47364RT

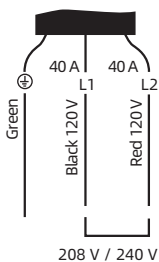

MT-C510065  
MT-T59165

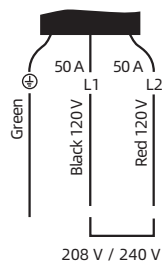

### Installation Checklist

- Read all the safety instructions in the front of your User Manual.
- Remove all packaging materials from your appliance before cooking.
- Confirm that the electrical power to the appliance is turned on.
- Test all cooking zones to make sure they are working properly (page ref).
- Remember to complete your product registration!

## SCHEMA DU RACCORDEMENT ÉLECTRIQUE

MT-C23503C-V2  
MT-T23003RT

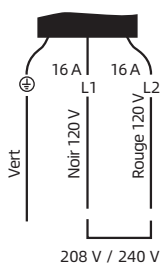

MT-C47464L8-V1.5  
MT-T47364RT

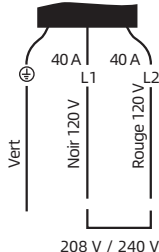

MT-C510065  
MT-T59165

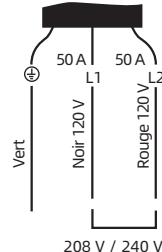

### Liste de contrôle d'installation

- Lisez toutes les consignes de sécurité au début de votre manuel.
- Retirez tous les matériaux d'emballage de votre appareil avant de faire cuire des aliments.
- Vérifiez que l'alimentation électrique de l'appareil est allumée.
- Testez tous les éléments de surface/brûleurs pour vous assurer qu'ils fonctionnent correctement (page ref).
- N'oubliez pas d'effectuer l'enregistrement de votre produit!

---

# CONTENTS

1	Safety Informations	12
1.1	Electrical Shock Hazard	12
1.2	General Instructions	12
1.3	Instructions on Use and Maintenance	13
2	General Information	15
2.1	Technical Data	15
2.2	Product Description	16
2.3	Control Panel	17
3	Commissioning	18
3.1	Cooking Utensil Guidelines	18
3.2	Choosing the Right Cookware	19
4	Operation	19
4.1	Before First Use	19
4.2	Moving Cookware on a Smooth Cooktop	19
4.3	Using the Touch Controls	19
4.4	To Start Cooking	20
4.5	When You Have Finished Cooking	20
4.6	Using Single/Double/Triple Elements	21
4.7	Using the Timer	21
4.8	Locking the Controls	22
4.9	Residual Heat Warning	23
4.10	Auto Shutdown	23
4.11	Cooking Guidelines	23
5	Cleaning and Care	25
6	Troubleshooting	26

## FCC Notice

Important: This appliance has been tested and found to comply with the limits for a class B digital device, pursuant to Part 18 of the FCC rules (United States) and ICES-001 (Canada). These limits are designed to provide reasonable protection against harmful interference in a residential installation. This unit uses and can radiate radio frequency energy and, if not installed and used in accordance with the instructions, may cause harmful interference to radio communications. However there is no guarantee that interference will not occur in a particular installation. If this unit does cause harmful interference to radio or television reception, which can be determined by turning the unit off and on, the user is encouraged to try to correct the interference by one or more of the following measures:

- Reorient or relocate the receiving antennae.
- Increase distance between unit and receiver.
- Connect the unit into an outlet or a circuit different from that to which the receiver is connected.

### FCC radiation exposure statement:

This equipment complies with FCC radiation exposure limits set forth for an uncontrolled environment. This equipment should be installed and operated so there is at least 8 inches (20 cm) between the radiator and your body. This device and its antenna(s) must not be co-located or operated in conjunction with any other antenna or transmitter.

## FOR YOUR SAFETY

When using electrical appliances, you should follow basic safety precautions, including the following:



### CAUTION

- Use this appliance only for its intended purpose as described in this Owner's Manual.
- Potentially hot surfaces include cooktop, the cooktop facing, and areas near the cooktop.

User servicing - Do not repair or replace any part of the appliance unless specifically recommended in this manual. All other servicing should be referred to a qualified technician.

Always disconnect the power to the appliance before servicing by removing the fuse or switching off the circuit breaker.



### WARNING

California Residents: Cancer and Reproductive Harm information, visit [www.P65Warnings.ca.gov](http://www.P65Warnings.ca.gov).

---

# 1 Safety Informations

## 1.1 Electrical Shock Hazard

- Disconnect the appliance from the mains electricity supply before carrying out any work or maintenance on it.
- Connection to a good earth wiring system is essential and mandatory.
- Alterations to the domestic wiring system must only be made by a qualified electrician.
- Failure to follow this advice may result in electrical shock or death.



### CAUTION

Risk of injury! Panel edges are sharp.  
Failure to use caution could result in injury or cuts.

## 1.2 General Instructions

- Read these instructions carefully before installing or using this appliance.
- No combustible material or products should be placed on this appliance at any time.
- Please make this information available to the person responsible for installing the appliance as it could reduce your installation costs.
- In order to avoid a hazard, this appliance must be installed according to these instructions for installation.
- This appliance is to be properly installed and earthed only by a suitably qualified person.
- This appliance should be connected to a circuit which incorporates an isolating switch providing full disconnection from the power supply.
- Use only cooktop guards designed by the manufacturer of the cooking appliance or indicated by the manufacturer of the appliance in the instructions for use as suitable or cooktop guards incorporated in the appliance. The use of inappropriate guards can cause accidents.
- Failure to install the appliance correctly could invalidate any warranty or liability claims.
- This device may be only used by children 8 years old or older and persons with limited physical, sensory and mental capabilities and / or lack of experience and knowledge, provided that they have been instructed in use of the device by a responsible person who understands the associated risks.
- The appliance is not a toy. Do not allow children to play with the appliance or sit, stand, or climb on it.
- In the interest of children, do not store anything in cabinets above the appliance. Children climbing on the Cooktop in secret may be seriously injured by falling objects.
- Do not leave children unattended while using the appliance. Cleaning and maintenance of the appliance must only be carried out under supervision by children over 8 years of age.
- If the supply cord is damaged, it must be replaced by the manufacturer, its service agent or similarly qualified persons in order to avoid a hazard.
- If the surface is cracked, switch off the appliance to avoid the possibility of electric shock, for cooktop surfaces of glass-ceramic or similar material which protect live parts.
- Metallic objects such as knives, forks, spoons and lids should not be placed on the cooktop surface since they can get hot.
- Do not use a steam cleaner to clean your Cooktop.
- The appliance is not intended to be operated by means of an external timer or separate remote-control system.

- The cooking process has to be supervised. A short term cooking process has to be supervised continuously.
- Unattended cooking on a cooktop with fat or oil can be dangerous and may result in fire. NEVER try to extinguish a fire with water, but switch off the appliance and then cover flame e.g. with a lid or a fire blanket.

 **WARNING**  
Risk of fire! Do not store other items on the cooking surfaces, except pans and pots.

### 1.3 Instructions on Use and Maintenance

#### Electrical Shock Hazard

- Do not cook on a broken or cracked Cooktop. If the Cooktop surface is break or crack, switch the appliance off immediately at the mains power supply (wall switch) and contact a qualified technician.
- Switch the Cooktop off at the wall before cleaning or maintenance.
- Failure to follow this advice may result in electrical shock or death.

#### Health Hazard

- This appliance complies with electromagnetic safety standards.
- However, persons with cardiac pacemakers or other electrical implants (such as insulin pumps) must consult with their doctor or implant manufacturer before using this appliance to make sure that their implants will not be affected by the electromagnetic field.
- Failure to follow this advice may result in death.

 **CAUTION**  
Risk of burns! During use, accessible parts of this appliance will become hot enough to cause burns. Do not let your body, clothing or any item other than suitable cookware contact the glass until the surface is cool.

- Never touch the cooking zones with your bare hand during use. Make sure that children do not touch the hot cooktop.
- Handles of saucepans may be hot to touch. Check saucepan handles do not overhang other cooking zones that are on. Keep handles out of reach of children.
- Failure to follow this advice could result in burns and scalds.

 **WARNING**  
Risk of injury! The razor-sharp blade of a Cooktop scraper is exposed when the safety cover is retracted. Use with extreme care and always store safely and out of reach of children. Failure to use caution could result in injury or cuts.

#### General Instructions

- Never leave the appliance unattended when in use. Boilover causes smoking and greasy spillovers that may ignite.
- Never use your appliance as a work or storage surface.
- Never leave any objects or utensils on the appliance.
- Do not place or drop heavy objects on your Cooktop.
- Do not stand on your Cooktop.
- Do not place or leave any magnetisable objects (e.g. credit cards, memory cards) or electronic devices (e.g. computers, MP3 players) near the appliance, as they may be affected by its electromagnetic field.
- Never use your appliance for warming or heating the room.

- 
- After use, always turn off the cooking zones and the Cooktop as described in this manual (i.e. by using the touch controls). Do not rely on the pan detection feature to turn off the cooking zones when you remove the pans.
  - Do not repair or replace any part of the appliance unless specifically recommended in the manual. All other servicing should be done by a qualified technician.
  - Do not use pans with jagged edges or drag pans across the induction glass surface as this can scratch the glass.
  - Do not use scourers or any other harsh abrasive cleaning agents to clean your Cooktop, as these can scratch the Induction glass.
  - This appliance is intended to be used in household and similar applications such as: staff kitchen areas in shops, offices and other working environments; farm houses; by clients in hotels, motels and other residential type environments; bed and breakfast type environments.
  - Children less than 8 years of age shall be kept away unless continuously supervised.
  - The power cord is no longer accessible after installation.

## 2 General Information

### 2.1 Technical Data

Model identification		MT-T47364RT	MT-T59165	MT-T23003RT
Serie		MEGAWATT 30	MEGAWATT 36	MEGAWATT 12
Type of cooktop		30" Built-In Cooktop	36" Built-In Cooktop	12" Built-In Cooktop
Maximum Connected Load: @ 240 Volts		7.3 kW	9.1 kW	3.0 kW
Maximum Connected Load: @ 208 Volts		6.3 kW	8.7 kW	2.6 kW
Minimum Circuit Required		40 Amps	50 Amps	16 Amps
Number of cooking zones		4	5	2
Heating technology		Radiant cooking	Radiant cooking	Radiant cooking
Displays	Control Location	Front Center	Front Center	Front Center
	Control Type	Electronic Touch	Electronic Touch	Electronic Touch
	Display Interface Color	Red	Red	Red
Diameter of circular cooking zones (Ø) and Power (max)	Left front	9" 2.3 kW	6.5" 1.2 kW	6-1/2" 1.8 kW
	Left rear	6.5" 1.2 kW	9" 2.2 kW	7-7/8" 1.2 kW
	Center	--	12" 2.7 kW	--
	Right front	6.5" 2.0 kW	8" 1.8 kW	--
	Right rear	8" 1.8 kW	6.5" 1.2 kW	--
Cooktop Dimension	Overall Width	30-5/16 inches	35-7/16 inches	11-7/16 inches
	Overall Depth	20-1/2 inches	20-1/2 inches	20-1/2 inches
	Overall Height	2-3/16 inches	2-3/16 inches	2-1/4 inches
Cabinet Dimension	Cabinet Width	30 inches	36 inches	12 inches
Cutout Size	Cutout Width	29-3/16 inches	34-5/16 inches	10-9/16 inches
	Cutout Depth	19-3/8 inches	19-3/8 inches	19-11/16 inches

## 2.2 Product Description

Cookzone sizes, 4 zones

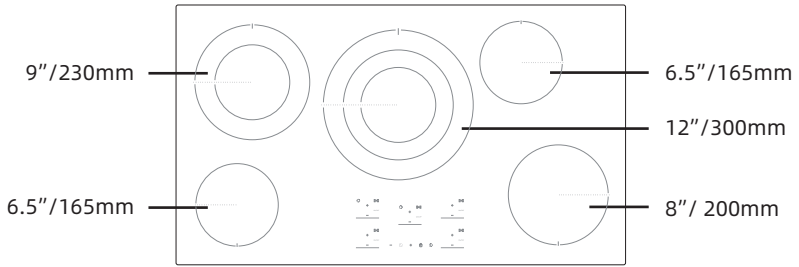

Cookzone sizes, 5 zones

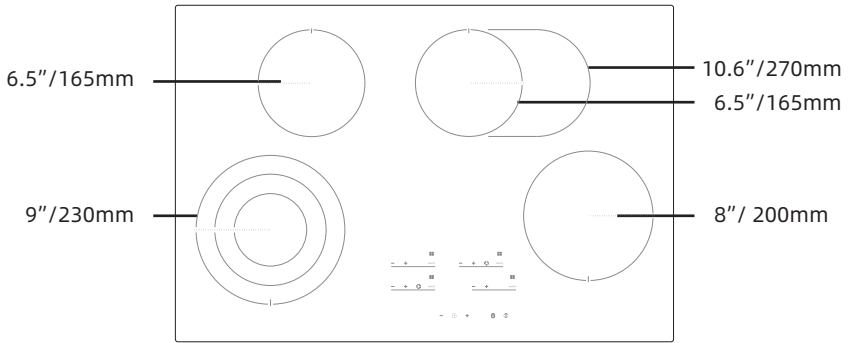

Cookzone sizes, 2 zones

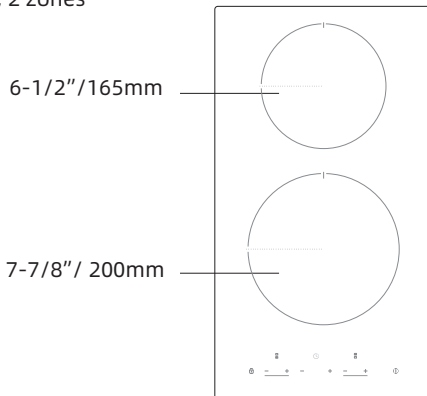

### 2.3 Control Panel

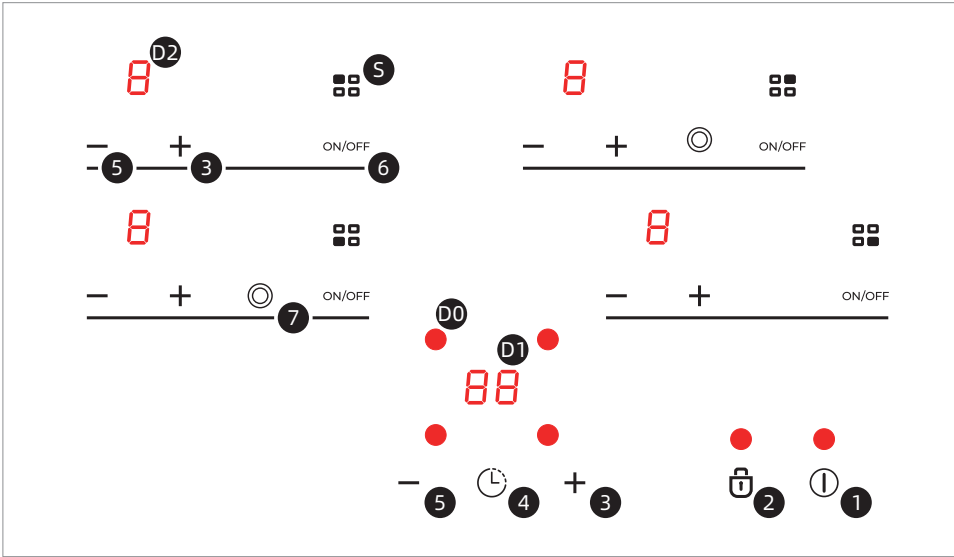

- ① Power: Press to turn on or turn off the cooktop.
- ② Lock: Lock the cooktop controls to prevent accidental activation of cooking zones.
- ③ Increase button: Press to increase the amount of
- ④ Timer On: Press to turn the countdown timer on.
- ⑤ Reduce button: Press to reduce the amount of
- ⑥ Cooking Zone On/Off: Press to turn ON/OFF for that zone.
- ⑥a Cooking Zone Selection
- ⑦ Dual/Triplex ring control
- D0 Timer Indicator: The LEDs indicate Timer is on.
- D1 Timer setting display: , ,
- D2 Power setting display: , ,
- S Zone sign

---

## 3 Commissioning

### 3.1 Cooking Utensil Guidelines

Type	Responses to Temperature Changes	Recommended Usage
Aluminum	Heats and cools quickly.	Frying, braising, roasting. May leave metal markings on glass.
Cast Iron	Heats and cools quickly.	Not recommended. Retains excessive heat and may damage cooktop.
Copper, Tin lined	Heats and cools quickly.	Gourmet cooking, wine sauces, egg dishes
Enamel Ware	Response depends on base metal.	Not recommended. Imperfections in enamel may scratch cooktop
Glass Ceramic	Heats and cools slowly.	Not recommended. Heats too slowly. Imperfections in enamel may scratch cooktop
Stainless Steel	Heats and cools at moderate rate.	Soups, sauces, vegetables, general cooking.

### 3.2 Choosing the Right Cookware

Do not use cookware with jagged edges or a curved base.



Make sure that the base of your pan is smooth, sits flat against the glass, and is the same size as the cooking zone. Always centre your pan on the cooking zone.

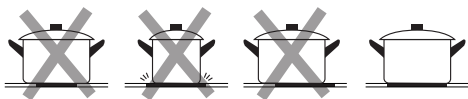

Always lift pans off the ceramic cooktop - do not slide, or they may scratch the glass.

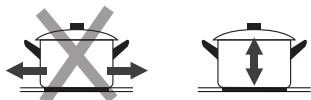

## 4 Operation

### 4.1 Before First Use

- Read this guide, taking special note of the "Safety Instructions" and "Instructions on Use and Maintenance" sections.
- Apply a ceramic cooktop cleaning cream (available in most hardware, grocery, and department stores) to the ceramic surface. Clean and buff with a clean paper towel. Cooktop cleaning creams leave a protective finish on the glass that will make cleaning easier when the cooktop is soiled from cooking and help prevent scratches and abrasions.

### CAUTION

- Do not place flammable items such as plastic salt and pepper shakers, spoon holders, or plastic wrapping on top of the range when it is in use. Heat radiating from cookware could cause these items to melt or ignite. Potholders, towels, or wooden spoons could catch fire if placed too close to hot cookware.

### 4.2 Moving Cookware on a Smooth Cooktop

It's best to lift cookware before moving it on the ceramic glass cooktop. Cookware that has a rough or dirty bottom can mark and scratch the ceramic glass surface. Always start with clean cookware.

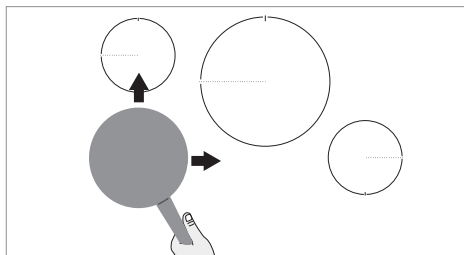

### 4.3 Using the Touch Controls

- The controls respond to touch, so you don't need to apply any pressure.
- Use the ball of your finger, not its tip.

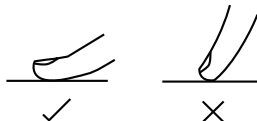

- You will hear a beep each time a touch is registered.
- Make sure the controls are always clean, dry, and that there is no object (e.g. a utensil or a cloth) covering them. Even a thin film of water may make the controls difficult to operate.

## 4.4 To Start Cooking

After power on, the buzzer beeps once, all the indicators light up for 1 second then go out, indicating that the cooktop has entered the state of standby mode.

1. Turn the the cooktop on by pressing the Power key. All the indicators show “-”.

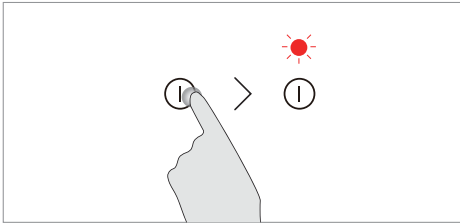

2. Place correctly sized cookware on the cooking zone that you wish to use. Make sure the bottom of the pan and the surface of the cooking zone is clean and dry.

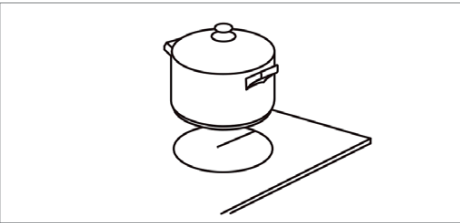

3. Press the On/Off control for the active cooking zone, and a S of Cooking Zone Indicator will light on, and a D2 of Power setting display next to the key will flash.

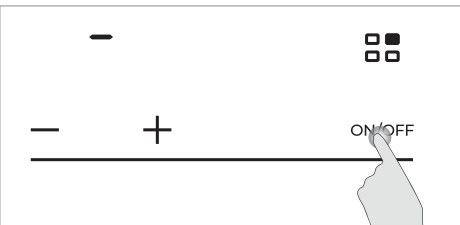

4. Set the cooking zone to the desired level by pressing the beneath “-/+” control.

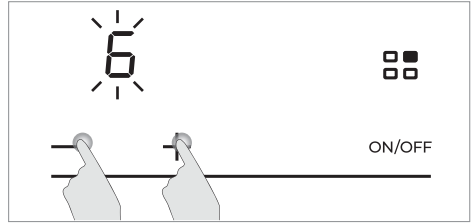

- If you don't choose power level within 1 minute, the cooktop will automatically switch off. You will need to start again at step 1.
- You can modify the power level at any time during cooking.



### IMPORTANT

Do not leave empty cookware on an operating cooking zone. Cookware will heat very quickly and may be damaged or warped if left on the cooking zone empty.

## 4.5 When You Have Finished Cooking

1. Press the On/Off control for the active cooking zone that you wish to switch off.

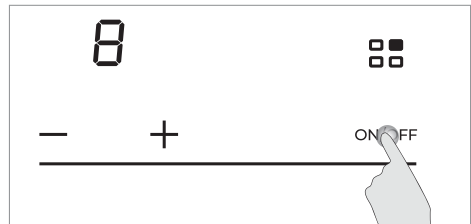

### Beware of hot surfaces

“H” will show which means cooking zone is too hot to touch. It will disappear when the surface has cooled down to a safe temperature.



## 4.6 Using Single/Double/Triple Elements

- Some cooking zones have variable size elements that can be selected using this Selection-key to control them.

Press the Selection-key to toggle the outer elements between single, double, and triple modes. The corresponding display will change accordingly.

- ☰ Triple Elements working modes
- ☷ Double Elements working modes

## 4.7 Using the Timer

- You can use the timer in two different ways:
- You can use it as a minute reminder. In this case, the timer will not turn any cooking zone off when the set time is up.
- You can set it to turn one cooking zone off after the set time is up.
- You can set the timer up to 99 minutes.

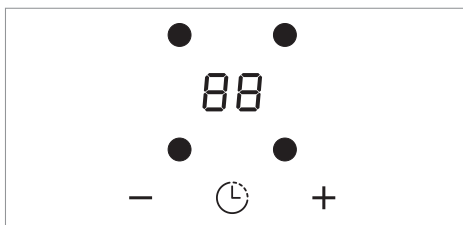

### Using the timer as a minute reminder

- Make sure the cooktop is turned on. Note: you can use the minute minder even if you're not selecting any cooking zone.
- After number of heating zone not flashing, touch timer control, then the reminder indicator will start flashing and "00" will show in the timer display.

- Set the time by touching the "+/-" control of the timer. Hint: Touch the "+/-" control of the timer once to decrease or increase by 1 minute. Hold the "+/-" control of the timer to decrease or increase by 10 minutes. Scrolling the "-" to the "00", the timer is cancelled.
- When the time is set, it will begin to count down immediately. The display will show the remaining time and the timer indicator will flash for 5 seconds.
- Buzzer will beeps for 30 seconds and the timer indicator shows "00" when the setting time finished.

### Setting the timer to turn one or more cooking zones off

- Select a heating zone by touching "☷☷" control, and a indicator between the key will flash, the default power setting is levels "5"
- When number of corresponding heating zone flashing, touch timer control, then the timer indicator will start flashing and "00" will show in the timer display.
- Set the time by touching the "+/-" control of the timer. Hint: Touch the "+/-" control of the timer once to decrease or increase by 1 minute. Hold the "+/-" control of the timer to decrease or increase by 10 minutes. Scrolling the "-" to the "00", the timer is cancelled.
- When the time is set, it will begin to count down immediately. The display will show the remaining time and the timer indicator will flash for 5 seconds. The red dot next to power level indicator will illuminate indicating that zone is selected.



#### IMPORTANT

When the timer stops or the tone sounds, the cooking zones will continue to operate.

The timer does not affect the cooking zone settings in any way.

## 4.8 Locking the Controls

You can use the child safety lock to safeguard against unintentionally turning on a cooking zone and activating the cooking surface. Also the control panel, with the exception of the Lock key (Only turn off control), can be locked in order to prevent the settings from being changed unintentionally, for example, by wiping over the panel with a cloth.

### Switching the child safety lock On/Off

On: Press the lock control. The above indicator will light up.

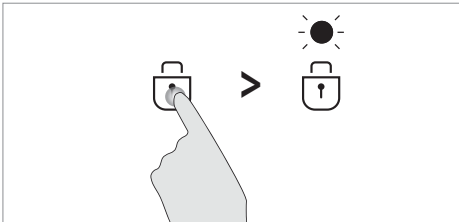

Off:

1. Make sure the cooktop is turned on.
2. Press and hold the Lock control for 3 seconds.

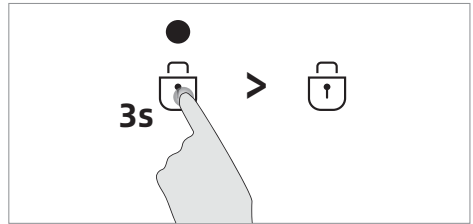

#### NOTE

When the cooktop is in lock mode, all the controls are disabled except the "ⓘ" and Lock, you can always turn the cooktop off with the "ⓘ" control in an emergency, but you shall unlock the cooktop first in the next operation.

## 4.9 Residual Heat Warning

When the cooktop has been operating for some time, there will be some residual heat. The display shows "H" to warn you of the residual heat so that you do not touch the cooktop while it is hot.

## 4.10 Auto Shutdown

Safety feature of the cooktop is auto shut down. This occurs whenever you forget to switch off a cooking zone. The default shutdown times are shown in the table below:

Power level	1	2	3	4	5	6	7	8	9
Default working timer (hour)	2	2	2	2	2	2	2	2	2

## 4.11 Cooking Guidelines



### WARNING

Take care when frying as the oil and fat heat up very quickly. At extremely high temperatures oil and fat will ignite spontaneously and this presents a serious fire risk.

### Cooking tips

- When food comes to the boil, reduce the temperature setting.
- Using a lid will reduce cooking times and save energy by retaining the heat.
- Minimize the amount of liquid or fat to reduce cooking times.
- Start cooking on a high setting and reduce the setting when the food has heated through.

### Simmering, cooking rice

- Simmering occurs below boiling point, at around 185 °F, when bubbles are just rising occasionally to the surface of the cooking liquid. It is the key to delicious soups and tender stews because the flavours develop without overcooking the food. You should also cook egg-based and flour thickened sauces below boiling point.
- Some tasks, including cooking rice by the absorption method, may require a setting higher than the lowest setting to ensure the food is cooked properly in the time recommended.

### Searing steak

1. Stand the meat at room temperature for about 20 minutes before cooking.
2. Heat up a heavy-based frying pan.
3. Brush both sides of the steak with oil. Drizzle a small amount of oil into the hot pan and then lower the meat onto the hot pan.
4. Turn the steak only once during cooking. The exact cooking time will depend on the thickness of the steak and how cooked you want it. Times may vary from about 2-8 minutes per side. Press the steak to gauge how cooked it is - the firmer it feels the more well done it will be.
5. Leave the steak to rest on a warm plate for a few minutes to allow it to relax and become tender before serving.

## For stir-frying

1. Choose a flat-based wok or a large frying pan.
2. Have all the ingredients and equipment ready. Stir-frying should be quick. If cooking large quantities, cook the food in several smaller batches.
3. Preheat the pan briefly and add two tablespoons of oil.
4. Cook any meat first, put it aside and keep warm.
5. Stir-fry the vegetables. When they are hot but still crisp, turn the cooking zone to a lower setting, return the meat to the pan and add your sauce.
6. Stir the ingredients gently to make sure they are heated through.
7. Serve immediately.

## Heat settings

Power level	Suitability
1-2	<ul style="list-style-type: none"><li>• Delicate warming for small amounts of food</li><li>• Melting chocolate, butter, and foods that burn quickly</li><li>• Gentle simmering</li><li>• Slow warming</li></ul>
3-4	<ul style="list-style-type: none"><li>• Reheating</li><li>• Rapid simmering</li><li>• Cooking rice</li></ul>
5-6	<ul style="list-style-type: none"><li>• Pancakes</li></ul>
7-8	<ul style="list-style-type: none"><li>• Sauteing</li><li>• Cooking pasta</li></ul>
9	<ul style="list-style-type: none"><li>• Stir-frying</li><li>• Searing</li><li>• Bringing soup to the boil</li><li>• Boiling water</li></ul>

## 5 Cleaning and Care



### NOTE

Before any maintenance or cleaning work is carried out, disconnect the appliance from electricity supply and ensure the appliances is completely cool.

EN

What?	How?	Important!
<p>Everyday soiling on glass (fingerprints, marks, stains left by food or non-sugary spillovers on the glass)</p>	<ol style="list-style-type: none"> <li>1. Switch the power to the Cooktop off.</li> <li>2. Apply a Cooktop cleaner while the glass is still warm (but not hot!)</li> <li>3. Rinse and wipe dry with a clean cloth or paper towel.</li> <li>4. Switch the power to the Cooktop back on.</li> </ol>	<ul style="list-style-type: none"> <li>• When the power to the Cooktop is switched off, there will be no “hot surface” indication but the cooking zone may still be hot! Take extreme care.</li> <li>• Heavy-duty scourers, some nylon scourers and harsh/abrasive cleaning agents may scratch the glass. Always read the label to check if your cleaner or scourer is suitable.</li> <li>• Never leave cleaning residue on the Cooktop: the glass may become stained.</li> </ul>
<p>Boilovers, melts, and hot sugary spills on the glass</p>	<p>Remove these immediately with a fish slice, palette knife or razor blade scraper suitable for ceramic glass Cooktops, but beware of hot cooking zone surfaces:</p> <ol style="list-style-type: none"> <li>1. Switch the power to the Cooktop off at the wall.</li> <li>2. Hold the blade or utensil at a 30° angle and scrape the soiling or spill to a cool area of the Cooktop.</li> <li>3. Clean the soiling or spill up with a dish cloth or paper towel.</li> <li>4. Follow steps 2 to 4 for “Everyday soiling on glass” above.</li> </ol>	<ul style="list-style-type: none"> <li>• Remove stains left by melts and sugary food or spillovers as soon as possible. If left to cool on the glass, they may be difficult to remove or even permanently damage the glass surface.</li> <li>• Cut hazard: when the safety cover is retracted, the blade in a scraper is razor-sharp. Use with extreme care and always store safely and out of reach of children.</li> </ul>

What?	How?	Important!
Spillovers on the touch controls	<ol style="list-style-type: none"> <li>1. Switch the power to the Cooktop off.</li> <li>2. Soak up the spill.</li> <li>3. Wipe the touch control area with a clean damp sponge or cloth.</li> <li>4. Wipe the area completely dry with a paper towel.</li> <li>5. Switch the power to the Cooktop back on.</li> </ol>	<ul style="list-style-type: none"> <li>• The Cooktop may beep and turn itself off, and the touch controls may not function while there is liquid on them. Make sure you wipe the touch control area dry before turning the Cooktop back on.</li> </ul>

## 6 Troubleshooting

Problem	Possible Cause	Solution
The cooktop cannot be turned on.	No power.	Make sure the cooktop is connected to the power supply and that it is switched on. Check whether there is a power outage in your home or area. If you've checked everything and the problem persists, call a qualified technician.
The touch controls are unresponsive.	The controls are locked.	Unlock the controls.
The touch controls are difficult to operate.	There may be a slight film of water over the controls or you may be using the tip of your finger when touching the controls.	Make sure the touch control area is dry and use the ball of your finger when touching the controls.
The glass is being scratched.	Rough-edged cookware. Unsuitable, abrasive scourer or cleaning products being used.	Use cookware with flat and smooth bases (see "Choosing the right Cookware" section). Do not use scouring pads or scouring agents for cleaning (see "Care and Cleaning" section).

Problem	Possible Cause	Solution
Some pans make crackling or clicking noises.	This may be caused by the construction of your cookware (layers of different metals vibrating differently).	This is normal, but the noise should quieten down or disappear completely when you decrease the heat setting.

### Information Codes

Displayed code	Possible cause	Solution
FA	Temperature sensor failure	Turn off the cooktop and then restart. If the problem continues, unplug the power cord for 30 seconds or more and then reconnect. If the problem is not fixed, please contact a local customer service.
E3	Abnormal temperature	

**EN** If there is a legal regulation for the disposal of electrical and electronic devices in your country, this symbol on the product or on the packaging indicates that this product must not be disposed of with household waste. Instead, it must be taken to a collection point for the recycling of electrical and electronic equipment. By disposing of it in accordance with the rules, you are protecting the environment and the health of your fellow human beings from negative consequences. For information about the recycling and disposal of this product, please contact your local authority or your household waste disposal service.

**FR** S'il existe une réglementation pour l'élimination ou le recyclage des appareils électriques et électroniques dans votre pays, ce symbole sur le produit ou sur l'emballage indique que cet appareil ne doit pas être jeté avec les ordures ménagères. Vous devez le déposer dans un point de collecte pour le recyclage des équipements électriques et électroniques. La mise au rebut conforme aux règles protège l'environnement et la santé de vos semblables des conséquences négatives. Pour plus d'informations sur le recyclage et l'élimination de ce produit, veuillez contacter votre autorité locale ou votre service de recyclage des déchets ménagers.

**TECASA**  
*Stylish Kitchen Life*

**TEL: 877-216-1818**