



WARNING

- Do not use this appliance if any part has been under water. Immediately call a licensed professional to inspect the appliance and to replace any part of the control system and any gas control which has been under water.
- Do not use substitute materials. Use only parts certified for the appliance.
- Should overheating occur or the gas supply fail to shut off, turn off the manual gas control valve to the appliance.
- Do not use an extension cord or an adapter plug with this appliance.
- Any alteration to the appliance or its controls can be dangerous and will void the warranty.
- Proper venting is required for the safe operation of this appliance.
- Ensure appliance venting is not blocked or partially blocked.
- Ensure that in cases of freezing weather the water heater and its water lines are protected to prevent freezing.



CAUTION

- **BURN HAZARD.** Hot exhaust and vent may cause serious burns. Keep away from the water heater unit. Keep small children and animals away from the unit.
- Hot water outlet pipes leaving the unit can be hot to touch. In residential applications, insulation must be used for hot water pipes below 36" due to burn risk to children.



WARNING

This product can expose you to lead, which is known to the state of California to cause cancer and birth defects or other reproductive harm. For more information, go to www.P65warnings.ca.gov.

- Read all installation instructions thoroughly before installing this product.
- If you have any questions or concerns about this device, please consult the manufacturer or its local agent.
- This water heater can only be installed indoors for indoor models.
- The model description is listed on the nameplate, which is located on the side panel of the water heater.

The principle of the water heater is shown below:

FDG340IN-CS90

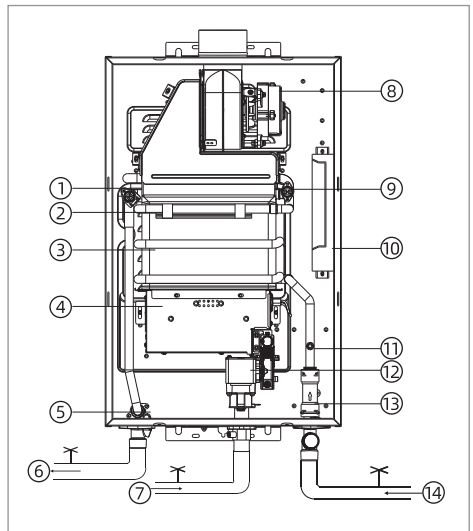

- ① Over temperature protection therm
- ② Heating device
- ③ Heat exchanger
- ④ Burners
- ⑤ Outlet temperature probe
- ⑥ Hot water
- ⑦ Gas
- ⑧ Fan module
- ⑨ Anti-freezing Thermostat
- ⑩ Computer board
- ⑪ Inlet temperature probe
- ⑫ Gas valves
- ⑬ Water flow sensor
- ⑭ Cold water

2 General Information

2.1 Function Introduction and Explanation

- The unit is a box less gas fast water heater designed to effectively supply hot water continuously during proper installation.

FDG420IN-CS120

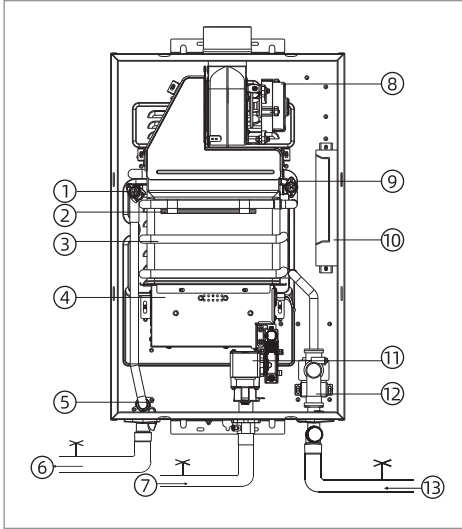

- ① Over temperature protection therm
- ② Heating device
- ③ Heat exchanger
- ④ Burners
- ⑤ Outlet temperature probe
- ⑥ Hot water
- ⑦ Gas
- ⑧ Fan module
- ⑨ Anti-freezing Thermostat
- ⑩ Computer board
- ⑪ Gas valves
- ⑫ Water flow sensor
- ⑬ Cold water

* This diagram illustrates tankless water heater design concepts only and does not accurately represent the water heater's physical description.

1. A hot water tap is turned on.
2. Water enters the heater.
3. The water flow sensor detects the water flow.
4. The computer initiates the fan motor and sends a signal to the igniter to create an ignition spark.
5. The gas ignites and flames appear within the burner chamber.

6. Water circulates through the heat exchanger and then gets hot.
7. Using thermistors to measure temperatures throughout the water heater, the computer modulates the gas and water valves to ensure proper output water temperature.
8. When the tap is turned off, the unit shuts down.

This series of gas water heaters with solar linkage function by default:

- a. When it is detected that the inlet water temperature reaches a predetermined value, the water heater does not start;
- b. When the combustion work is started, and the inlet water temperature is less than the set temperature by 4 °F (2 °C), the water heater stops working;
- c. When the combustion work is started, if the inlet water temperature is ≥ 140 °F (60 °C), the water heater stops working.

Controller temperature adjustment range		95~149 °F (30 °C~65 °C)
System start condition	Inlet water temperature	< 113 °F (45 °C)
	Set temperature-inlet water temperature	< 7 °F (4 °C)
Normal combustion conditions	Inlet water temperature	< 140 °F (60 °C)
	Set temperature-inlet water temperature	< 4 °F (2 °C)

2.2 Dimensions and Connection Points



NOTICE

The images used in this document are for reference purposes only. Components and component locations may vary according to specific product models. Measurements may vary ± 0.38 in. (10 mm).

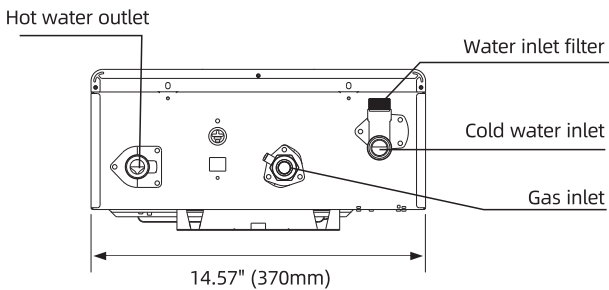
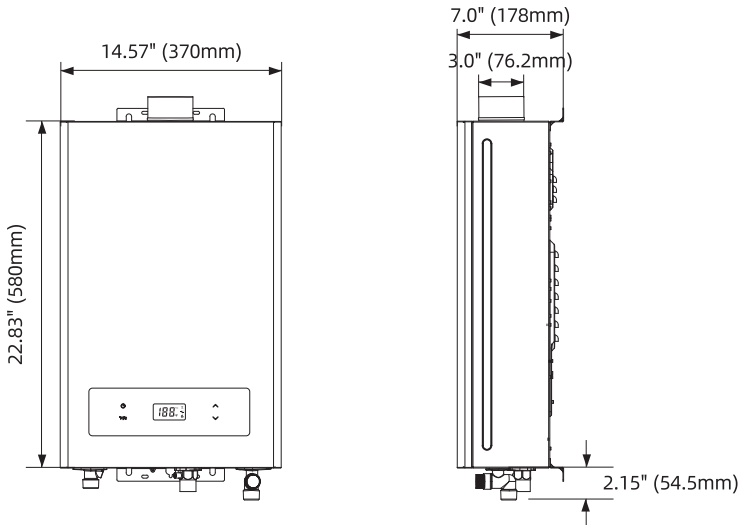

2.3 Technical Parameters

MODEL		FDG-CS90	FDG-CS120
Part No.		FDG-CS90AG-NG FDG-CS90AG-LP	FDG-CS120BW-NG FDG-CS120BW-LP
Natural Gas Input (Operating Range)	Btu/hr	Min. 9,000 Max. 90,000	Min. 9,500 Max. 120,000
Propane Input (Operating Range)	Btu/hr	Min. 9,000 Max. 90,000	Min. 9,500 Max. 120,000
Activation flowrate	GPM/min	0.53	
Rated power	W/A	20 W/0.25 A	37 W/0.44 A
Standby	W/A	1/0.03	
Freeze-Protection	W/A	100/0.85	
Supply	VAC/Hz	120/60	
Gas connection Water Connections	inch	3/4" NPT	
Water Pressure *	PSI (MPa)	15-150 (0.1-1.0)	
Natural gas Inlet Pressure	"W.C. (KPa)	Min. 3.5 (0.87) Max. 10.5 (2.61)	
Propane Inlet Pressure	"W.C. (KPa)	Min. 8.0 (1.99) Max. 13.0 (3.23)	
Weight	lbs (kg)	24.47 (11.1)	25.57 (11.6)
Dimensions	inch	H 22.76" × W 14.57" × D 7" H 580 × W 370 × D 178	
	mm		
Ignition		Electric Ignition	
Water heater Category **		Category III	
Not recommended in excess of 2,000 ft. above sea level.			

* 15 psi or above is recommended for flow.

** Water heater Category - water heaters of other than direct vent type, for outdoor. installation, are divided into four categories based on static pressure produced in the vent and flue loss.

Category I - a water heater that operates with a non-positive vent static pressure and with a vent gas temperature that avoids excessive condensate production in the vent.

Category II - a water heater that operates with a non-positive vent static pressure and with a vent gas temperature that may cause excessive condensate production in the vent.

Category III - a water heater that operates with a positive vent static pressure and with a vent gas temperature that avoids excessive condensate production in the vent.

Category IV - a water heater that operates with a positive vent static pressure and with a vent gas temperature that may cause excessive condensate production in the vent.



NOTICE

installation, are divided into four categories based on static pressure produced in the vent and flue loss.

2.4 Component Diagram

FDG-CS90

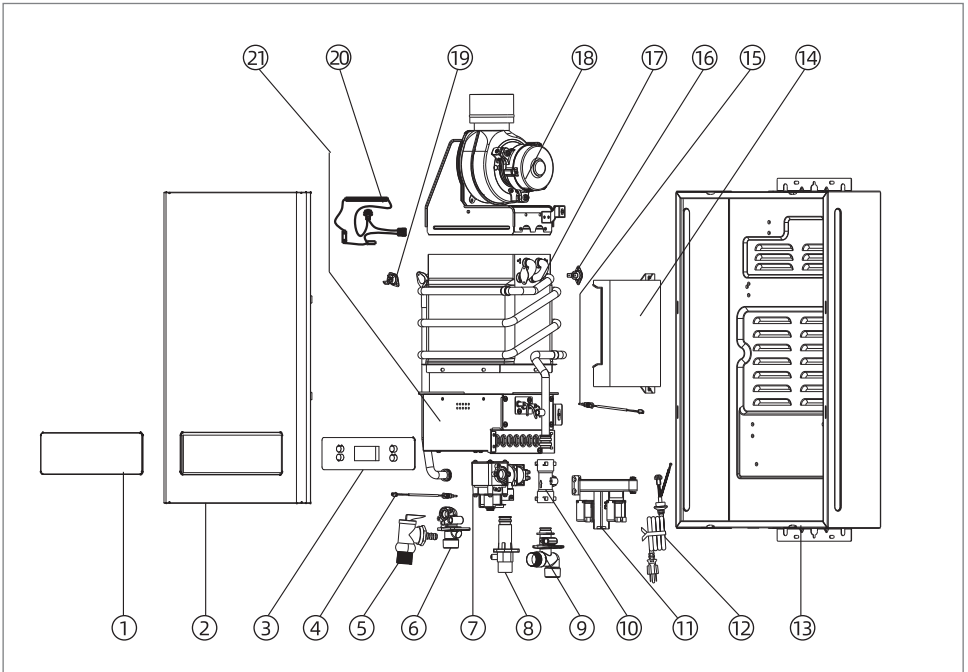

- | | |
|---------------------------------------|-------------------------------------|
| ① Decoration board | ⑫ Power line |
| ② Front panel | ⑬ Back panel |
| ③ Display assembly | ⑭ Computer board |
| ④ Water outlet temperature sensor | ⑮ Inlet water temperature probe |
| ⑤ Pressure relief valves (for canada) | ⑯ Anti-freezing Thermostat |
| ⑥ Connector | ⑰ Heat exchanger |
| ⑦ Proportional valve | ⑱ Fan module |
| ⑧ Intake connector | ⑲ Over temperature protection therm |
| ⑨ Water inlet connector | ⑳ Heating device |
| ⑩ Water flow sensor | ㉑ Burner |
| ⑪ Manifold | |

FDG-CS120

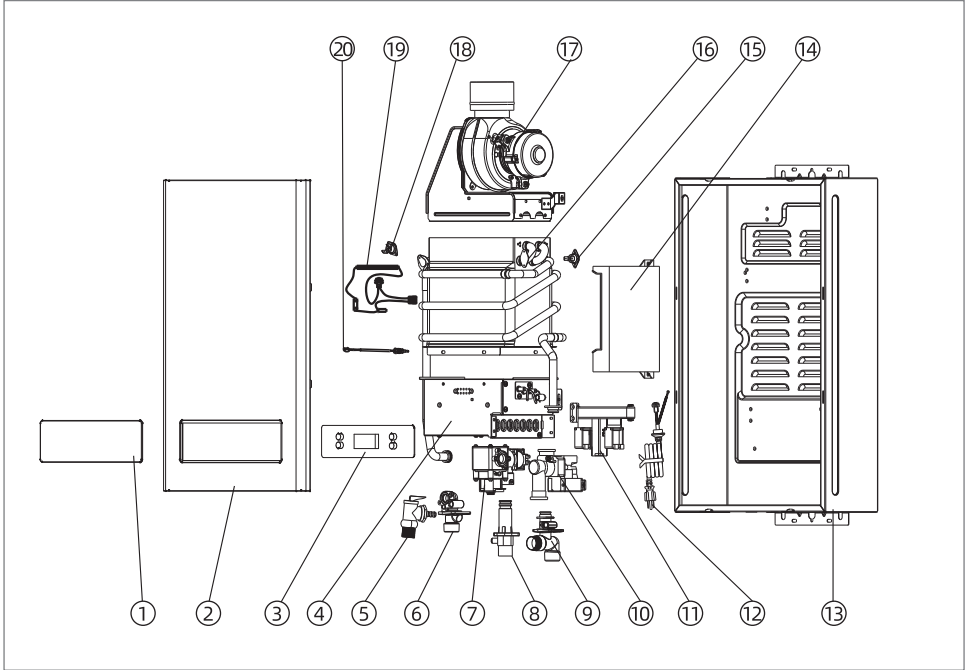

① Decoration board

② Front panel

③ Display assembly

④ Burner

⑤ Pressure relief valve (for canada)

⑥ Connector

⑦ Proportional valve

⑧ Intake connector

⑨ Water inlet connector

⑩ Water control valve flow sensor

⑪ Manifold

⑫ Power line

⑬ Back panel

⑭ Computer board

⑮ Anti-freezing Thermostat

⑯ Heat exchanger

⑰ Fan module

⑱ Over temperature protection therm

⑲ Heating device

⑳ Water outlet temperature sensor