

MIZUDO

Comfort with Innovation

MODEL:

ET036

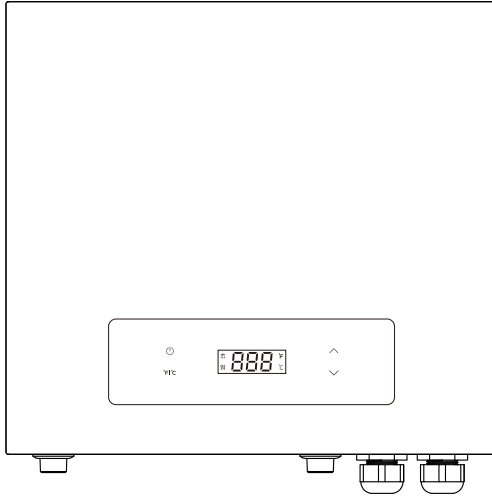

Electric Tankless Water Heater

Installation and Operation Manual

WARNING

Please read all instructions before using this water heater. Failure to follow the information in these instructions may result in fire, electric shock, property damage, injury or death.

CONTENTS

1 Safety Information	04
1.1 Safety Definitions	04
1.2 General Information	04
1.3 Important Safety Messages	04
2 General Information	05
2.1 Introduction and Explanation	05
2.2 Dimensions and Connection Points	06
2.3 Technical Parameters	07
2.4 Component Diagram	08
3 Installation	09
3.1 Installation Instructions	09
3.2 Prepare for Installation	10
3.3 Installation Dimensions	10
3.4 Installation Method	11
3.5 Water Connections	12
3.6 Electrical Connection	13
3.7 Commissioning the Water Heater	14
4 Operation	15
4.1 Operation Instructions	15
5 Maintenance	16
6 Troubleshooting	17
6.1 Fault Assessment and Troubleshooting	17
6.2 Diagnostic Codes	18
7 Wiring Diagrams	19
8 Packing List	20
Warranty Policy	21



NOTICE

- As the appliance undergoes upgrades, there may be differences between the actual appliance and the one described in the manual, so the content is subject to change without prior notice. Please consult the actual product.

SAVE THESE INSTRUCTIONS.

1 Safety Information

1.1 Safety Definitions

This manual has safety information and instructions to help you eliminate or reduce the risk of accidents and injuries.



DANGER

Indicates an imminently hazardous situation which, if not avoided, will result in death or serious injury.



WARNING

Indicates a hazardous situation that, if not avoided, could result in death or serious injury.



CAUTION

Indicates a hazardous situation which, if not avoided, could result in property damage and minor or moderate injury.



NOTICE

This symbol indicates important information where there is no risk to people or property.

1.2 General Information

- Read this entire manual. Failure to follow all the guidelines, instructions, and rules could cause personal injury or property damage.
- Improper installation, adjustment, alteration, service, and use of this unit can result in serious injury.
- This unit must be installed by a licensed electrician and plumber.
- The installation must comply with all national, state and local plumbing and electric codes. Proper installation is the responsibility of the installer. Failure to comply with the installation and operating instructions or improper use voids the warranty.
- Save these instructions for future reference. The installer should leave these instructions with the consumer.

- If you have any questions regarding the installation, use or operation of this water heater, or if you need any additional installation manuals, please call our technical service line.

1.3 Important Safety Messages

Observe the following safety information and regulations.

Operate the appliance only when fully installed and with all safety equipment fitted.

1.3.1 Intended Use

The appliance is intended for heating domestic hot water and can supply several draw-off points.

Any other use beyond that described shall be deemed inappropriate, and may void the manufacturer's warranty.

Observation of these instructions is also part of the correct use of this appliance.

1.3.2 Safety Precautions



DANGER: Electrocutation

Before proceeding with any installation, adjustment, alteration, or service of this appliance, all circuit breakers and disconnect switches servicing the appliance must be turned off. Never remove the appliance's cover unless the electricity servicing the appliance is turned off. Failure to do so could result in personal injury or death.



The appliance must be properly grounded. Failure to electrically ground the product could result in serious personal injury or death.

**DANGER: Burns**

Water temperatures over 125°F (52°C) can cause severe burns instantly or death from scalding. A hot water scalding potential exists if the thermostat on the appliance is set too high. Households with small children, disabled or elderly persons may require that the thermostat be set at 113°F (45°C) or lower to prevent possible injury from hot water.

**WARNING: injury**

Where children or persons with limited physical, sensory or mental capabilities are to be allowed to control this appliance, ensure that this will only happen under supervision or after appropriate instructions by a person responsible for their safety. Children should be supervised to ensure that they never play with the appliance.

**WARNING**

This product can expose you to lead, which is known to the state of California to cause cancer and birth defects or other reproductive harm. For more information, go to www.P65warnings.ca.gov.

2 General Information

2.1 Introduction and Explanation

The units are designed to supply hot water for a house, apartment or certain commercial applications.

Unlike a conventional storage type water heater, the tankless water heater does not store hot water. Instead, water is heated instantaneously as it flows through the unit. The unit offers greater energy efficiency than storage type water heaters due to the absence of stand-by losses and reduced hot water pipe runs.

The input of heat into the water is controlled electronically. The units will deliver any water temperature between 86 °F (30 °C) and 140 °F (60 °C). Set the desired temperature using the control key on the front cover. The unit's temperature adjustment control key can be set to: OFF, 86-140 °F (30-60 °C). The maximum temperature is electronically limited to 140 °F (60 °C).

For reasons of appliance efficiency and durability (scaling), the optimum temperature setting lies between 86 °F (30 °C) and 120 °F (50 °C).

1.3.3 Test Symbols

See the type label on the appliance.

1.3.4 Licences / certificates

- UL (U.S.A) Std. 499
- CSA (Canada) Std. C22.2 No.64

2.2 Dimensions and Connection Points

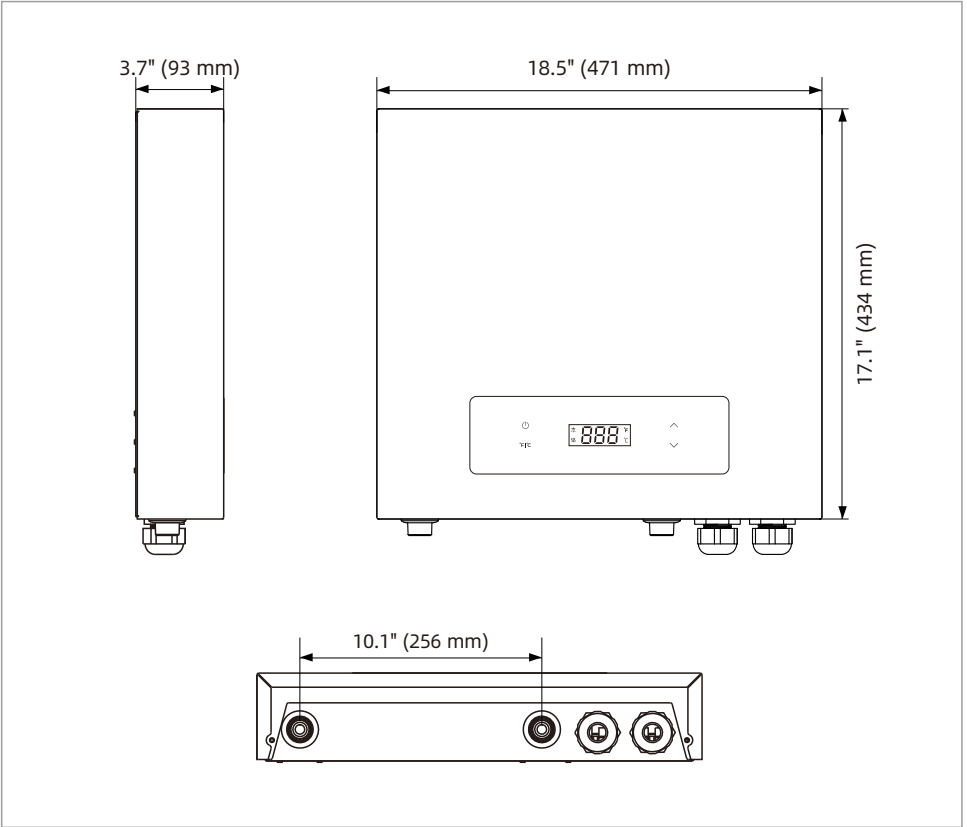

2.3 Technical Parameters

Model	ET036
Voltage	240 V
Wattage	36 kW
Min. Required Circuit Breaker Size	4 X 40 A
Max. Amperage	150 A
Recommended Wire Size	4 X 8 AWG
Min. Water Flow to Activate the Unit	0.92 GPM / 3.5 L/min
Safe Operating Pressure	3 PSI - 120 PSI
Water Connections	3/4" NPT
Installation	Wall mounted
Temperature Setting	Digital Panel
Dimensions (H x W x D)	18.5" x 17.1" x 3.7" (471 x 434 x 93 mm)

2.4 Component Diagram

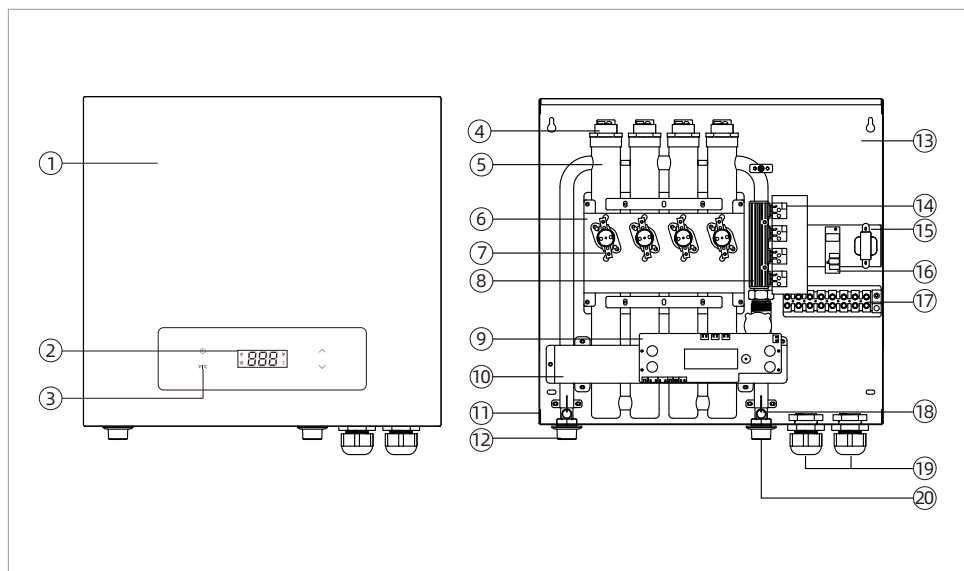

- | | |
|-------------------------|-----------------------------------|
| ① Front Cover | ⑪ Outlet water temperature probe |
| ② LED Display | ⑫ Hot water connection |
| ③ Control Key | ⑬ Bottom case |
| ④ Heating element | ⑭ Silicon controlled rectifier |
| ⑤ Copper cup | ⑮ Transformer |
| ⑥ Thermostat bracket | ⑯ Filter board |
| ⑦ Thermostat | ⑰ Terminal block |
| ⑧ Cooling fin | ⑱ Inlet water temperature probe |
| ⑨ Display assembly | ⑲ Power cord waterproof connector |
| ⑩ Display board bracket | ⑳ Cold water connection |

3 Installation

3.1 Installation Instructions



WARNING

- High voltage electrical installations should be performed by professional electricians.
- Installation must comply with the National Electrical Code, local electrical and plumbing codes.



NOTICE

Unit must be installed in a vertical position with the water fittings pointing downward.



WARNING

Do not install unit where it would routinely be splashed with water. Electric shock may result.



CAUTION

Hot water outlet pipes leaving unit can be hot to the touch. Insulation must be used for hot water pipes below 36" (0.9 m) due to burn risk to children.



NOTICE

This unit should not be installed in a location where it may be exposed to temperatures less than 36 °F (2 °C). If the unit may be subject to freezing temperatures all water must be drained from the unit. Failure to comply with this instruction voids all warranties.

The unit should be located in an area where water leakage from the unit or connections will not result in damage to the area adjacent to the unit. If such a location cannot be avoided it is recommended that a drain pan be installed under the unit.

- The unit must be installed in a circuit suitable for overcurrent. Must be grounded at the breaker panel.
- This unit must be permanently connected to a fixed circuit breaker. If you are not using the unit, turn off the circuit breaker.
- Do not install the unit near an open flame or in a strong magnetic field. This unit needs to be installed vertically. This unit should be connected to water first and then to electricity.

Guidelines You Need to Be Aware of

- This unit is designed for indoor installation only. However, it may be installed in an outdoor location as long as it is mounted in a suitable enclosure that provides protection from rain, splashed water, freezing temperatures, direct sunlight, debris, and insects.
- Install unit as close as possible to the main hot water draw off points.
- Install unit in a frost free area. If frost might occur, remove unit before freezing temperatures set in.
- Leave a minimum of 5" (120 mm) of clearance on all sides for servicing.
- DO NOT install under water pipes or air conditioning lines that might leak or condense moisture that could then drip onto the unit.
- DO NOT install above electrical boxes or junctions.



CAUTION

The water heater should not be located in an area where leakage will result in damage to the area adjacent to it or to lower floors of the structure. Where such areas cannot be avoided, it is recommended that a suitable catch pan, adequately drained, be installed under the water heater.

- Make sure the product is intact and complete with accessories.
- Please ensure that the main power supply, water pressure, grounding conditions, ammeter and wires meet the installation requirements.

3.2 Prepare for installation

■ Parts included

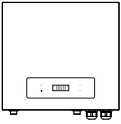

Electric Tankless Water Heater



User Manual

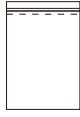

Assembly Kit

■ Tools needed (Not included)



Phillips screwdriver



Hammer



Hammer Drill With Concrete Bits



Ruler

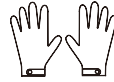

Gloves



Pencil

3.3 Installation Dimensions

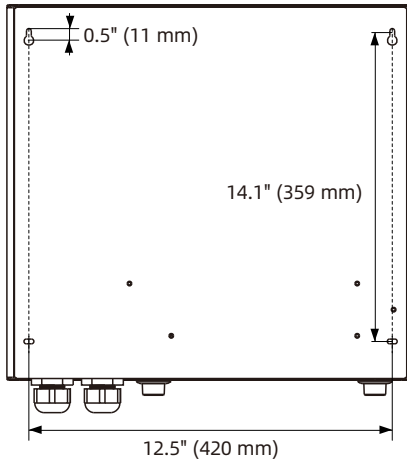

3.4 Installation Method

1. Figure out where to mount the water heater unit, mark 4 mounting holes on the wall according to the water heater or installation guide. (Fig.1).

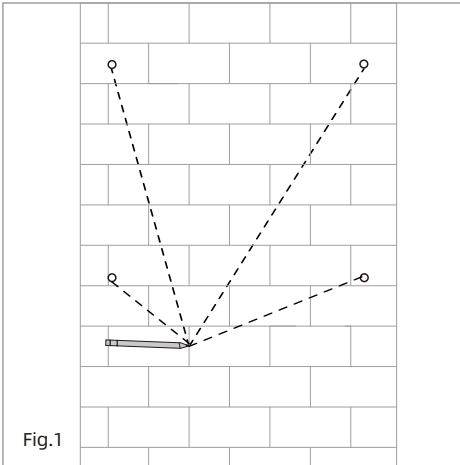

2. Use a hammer drill with concrete bits to create a hole in the wall according to the punching mark, ensuring it is 0.24" (6mm) in diameter and 1.02-1.1" (26-28mm) in depth. Then, insert the matching 4-M4 plastic wall anchors into the hole (Fig.2).

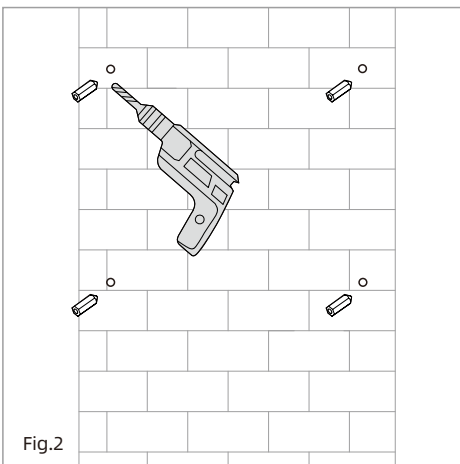

3. Insert M4 screws into the two upper holes, leaving about 0.12 inches to 0.2 inches (3-5mm) not tightly fastened (Fig.3).

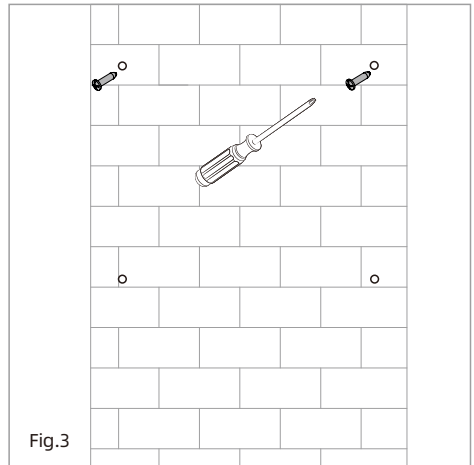

4. Use a screwdriver to remove the four screws at the top and bottom, then open the front cover (Fig.4).

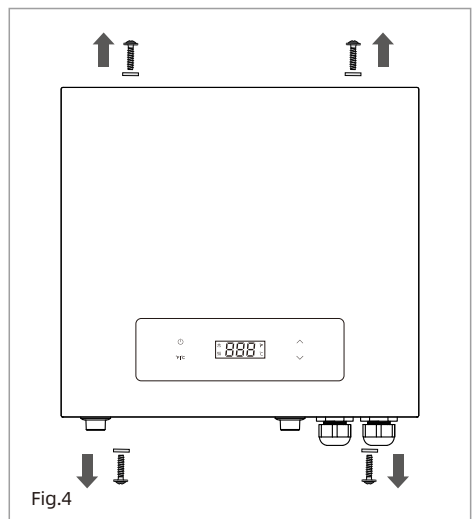

5. Hang the machine on the two previously installed screws, then secure the lower two screws. Finally, tighten the upper two screws (Fig.5).

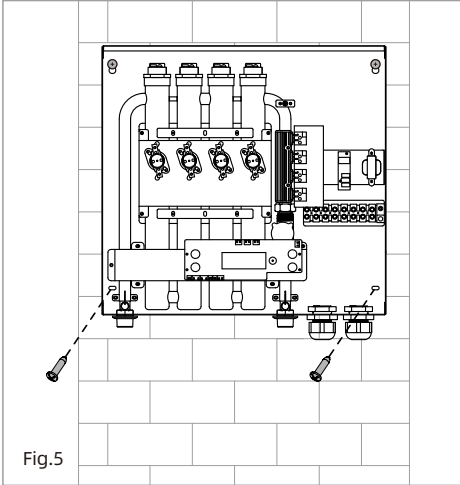

6. After completing all plumbing and electrical connections, install the front cover and tighten the four upper and lower screws with a screwdriver.

3.5 Water Connections



NOTICE

Excessive heat from soldering on copper pipes near the Unit may cause damage. The cold water connection to the unit must be disconnected periodically in order to clean the filter screen. It is required to use water connections that are easily detachable such as braided steel flex connectors.



CAUTION

Hard water or water with a high mineral count may damage the unit. Damage to the unit caused by scale or a high mineral count is not covered under the warranty.

- All plumbing work must comply with national and applicable state and local plumbing codes.
- A pressure reducing valve must be installed if the cold water supply pressure exceeds 150 PSI (10 bar).
- Make certain that the cold water supply line has been flushed to remove any scale and dirt.
- The unit has a built-in filter screen that should be cleaned from time to time. Clean screen and put the screen and the washer back into their original position.

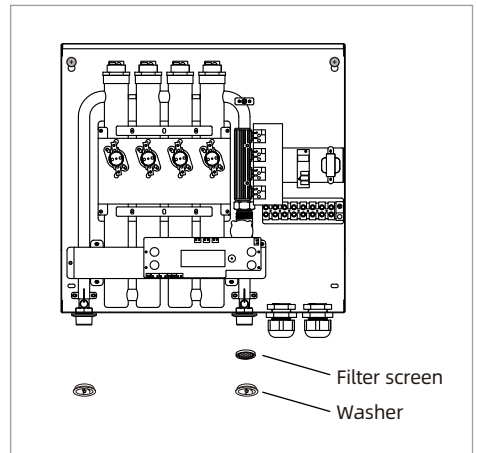

- The cold water connection (inlet) is on the right side of the unit, and the hot water connection (outlet) is on the left side of the unit.



CAUTION

Tankless water heaters are not required to be equipped with a temperature and pressure relief valve (T&P). If the local inspector will not pass the installation without a T&P, it should be installed on the hot water outlet side of the unit.

- The unit on the hot side is designed for connection to copper tubing, PEX tubing or a braided stainless steel hose with a female tapered thread.
- The plumbing on the cold water inlet side needs to be such that it can easily be removed to allow access to the inlet filter screen. The easiest way to achieve this is to use a stainless steel braided hose connector. If soldering near the unit is necessary, please direct the flame away from the housing of the unit in order to avoid damage.
- When all plumbing work is completed, check for leaks and take corrective action before proceeding.

3.6.1 Circuit Layout

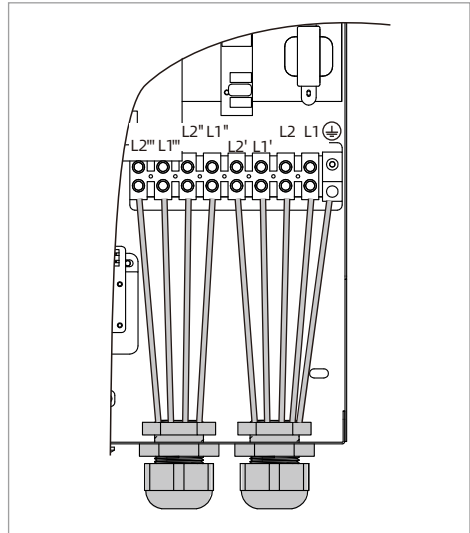

3.6 Electrical Connection



WARNING: Electrocutation

Before beginning any work on the electric installation, be sure that main breaker panel switches are "Off" to avoid any danger of electric shock. All mounting and plumbing must be completed before proceeding with electrical hook-up. Where required by local, state or national electrical codes the circuits should be equipped with a "ground fault interrupter".

The unit must be properly grounded in accordance with state and local codes, or in absence of such codes, in accordance with national electric code or the Canadian electric code. Failure to electrically ground the product could result in serious personal injury or death.

- The unit should be connected to properly grounded dedicated branch circuits of proper voltage rating. Ground must be brought to the "Ground" at the circuit breaker panel.

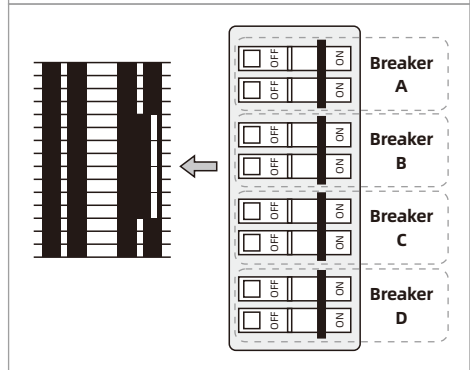

These units can be connected to a single circuit. Use a supply cable protected by a double pole breaker.



WARNING

- Must be connected to 4 sets of 240V power. Each set power needs to be connected to a two-pole breaker.
- L1 & L2 must be connected to breaker A, L1' & L2' must be connected to breaker B, L1'' & L2'' must be connected to breaker C, L1''' & L2''' must be connected to breaker D.

3.6.2 Circuit Connection

Please refer to "2.3 Technical Parameters" for the correct wire and circuit breaker size. In all cases, make sure that the unit is properly grounded.

- Cut the electrical connection cable to length and strip.

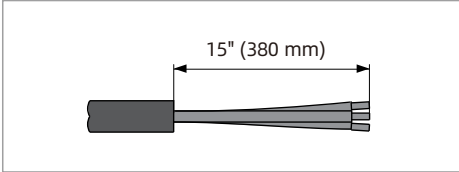

The wire must be fed through the Cord clamp (See "3.6.1 Circuit Layout"). The "live" wires must be connected to the slots on the terminal block marked L1 and L2. The ground wire must be connected to slot marked with the ground symbol (See "7 Wiring Diagrams").

3.6.3 Terminal Block

Consult the chart below for the recommended torque amounts on the terminal block screws.

Screw Size (mm)	Min. Torque (N·cm)	Min. Torque (lbf·in)
M6	200-250	17.7-22.1

Using the proper torque specifications to secure wire to the wiring block helps to avoid personal loss or property damage.

3.7 Commissioning the Water Heater



WARNING

Open the hot water faucet for a few minutes until water flow is continuous and all air is purged from water pipes. The unit's cover must be installed before the circuit breakers are turned on.

- Fill the unit up completely with water.
- Close the cover and fix it using the screw with the lock washer.
- Turn on circuit breakers to bring electrical power to the unit.
- Adjust the water temperature to the desired level using the knob on the front cover of the unit.
- Turn on hot water and wait twenty seconds until temperature has stabilized.
- Check the water temperature with your hand and make sure that it does not feel too hot. Reduce if necessary.
- Explain to the user how the unit works and familiarize them with its use.
- Advise the user about possible hazards (hot water temperature up to 140 °F (60 °C)). Hand over these instructions, to be kept for future reference.

4 Operation

4.1 Operation Instructions



WARNING

Do not store or use gasoline or other flammable vapors and liquids in the vicinity of this or any other appliance.

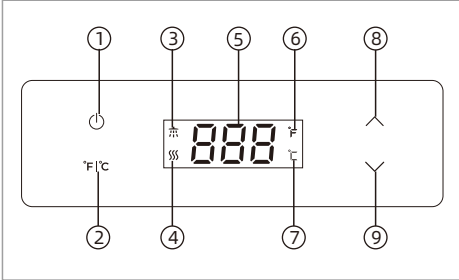

- | | |
|-------------------------------|--------------------|
| ① Switch button | ⑥ Fahrenheit |
| ② Fahrenheit/Celsius Priority | ⑦ Celsius |
| ③ Water flow signal | ⑧ Heat up button |
| ④ Water is heating up | ⑨ Heat down button |
| ⑤ Outlet water temp | |

1. Turn on the circuit breaker to supply electrical power to the unit.
2. Open the water faucet for a few minutes until the water flow is continuous and all the air has been purged from the water pipes.
3. After the device is powered on, there will be a "beep" sound, and the appliance keeps standby.
4. Press "⏻" to start.
5. Press "∧" and "∨" to adjust the temperature. Temperature setting range is 86 - 140°F (30-60°C)

Temperature unit selection:

Press the "F|C" you can make "°F" and "°C" selection, this unit default °F

Power failure memory function:

After power failure, the machine has a power failure memory, after restoring the incoming call, keep the last set temperature.

- If the unit has been paused, you may initially get a short burst of very hot water when you turn it on again. Please run the water through for a few seconds to let the temperature settle down. Please check the hot water with your hand before taking a shower.
- If the unit is not used in winter drain out the water completely so that the heater does not freeze.
- Please clean the inlet filter and the shower periodically in order to keep a proper water flow.



WARNING

Minors are not allowed to operate the water heater themselves unless accompanied by a guardian.

5 Maintenance



CAUTION

- Do not attempt to repair this water heater yourself if the unit is not working properly. Call a technician for assistance.
- The power supply always needs to be shut off before these operations are carried out.

To ensure consistent Maximum performance of the unit, it is recommended to follow these instructions:

- The tankless water heaters are designed for a very long service life. Actual life expectancy will vary with water quality and use. To ensure consistent water flow, it is recommended to periodically remove scale and dirt that may build up at the aerator of the faucet(s), the filter screen in the unit, or the heating canisters of the water heater.
- Periodically check the water quality supplied to the water heater. Water quality can have an impact on appliance longevity and may not be covered under the manufacturer's warranty.
- Periodically remove scales and dirt that may build up at the aerator of the faucet or in the shower head.
- There is a built-in filter at the inlet connection which should be cleaned from time to time. Please cut the water supply before doing this.
- If you live in hard water area and you get a descale device installed prior to the tankless water heater, it is recommended that you should annually change the filter for the descale device, or do it according to the instruction of its manufacturer.

Important Note:

1. Any maintenance performed on the water heater unit may introduce air into plumbing pipes, it is important to purge all the air out before power on again.
2. If you have a water supply with high level of mineralization(hard water), you should increase the frequency of your maintenance. Check the descale device regularly to see if it is functional.
3. Do not use thinner, alcohol, petrol, or any other organic solutions to clean the set. Use only a damp cloth with mild detergent.

6 Troubleshooting

6.1 Fault Assessment and Troubleshooting

Problems	Possible Causes	Corrective Actions
Digital display is not activated	No power or incorrect wiring	Check breakers at main electrical panel to ensure it is not tripped. If tripped, reset breaker. Check that water heater is wired correctly.
	Not enough flow	Turn on hot water at fixture.
No hot water	No power or incorrect wiring	Check breakers at main electrical panel to ensure it is not tripped. If tripped, reset breaker. Check that water heater is wired correctly.
	Overtemperature protection has been triggered	The water heater is equipped with software that turns off the heating elements when water temperatures reach a dangerous level. Turn off hot water, wait several minutes for water to cool.
	Flow rate is too low	Each model water heater has an activation flow rate. If the water flow is less than this flow level, unit will not heat water. Increase the flow rate.
Hot water supply is warm, but it does not get hot	Temperature set point is too low	Increase the temperature set point, be cautious of scald risk.
	Flow rate is too high	Reduce flow rate.
	Voltage less than 240 VAC	The heating elements on your water heater are designed for 240 VAC applications. When used a lower voltage, the water heater will produce less hot water.
	No power or incorrect wiring	Check breakers at main electrical panel to ensure it is not tripped. If tripped, reset breaker. Check that water heater is wired correctly.
	Mixing too much cold water	Tankless water heaters do not require mixing as much cold water as a conventional storage water heater. Adjust handle of fixture or mixing valve on faucet to reduce the amount of cold water mixed.
	Cold inlet temperature may be lower during winter months	This is normal. The colder inlet water requires more heat to reach the temperature set point. Increase the temperature set point.
Water is too hot	Temperature set point too high	Reduce temperature set point.

6.2 Diagnostic Codes

Error Code	Fault description and troubleshooting step
E1	<p>Over temperature protection: If the outlet water temperature is >149 °F (65 °C), stop heating; When the outlet water temperature is <140 °F (60 °C), resume the heating operation; When the outlet water temperature >158 °F (70 °C), stop working and display E1. After troubleshooting, power off and restart to restore.</p>
E3	<p>Inlet water temperature sensor failure (after troubleshooting, power off and restart to recover).</p>
E4	<p>Outlet water temperature sensor failure (after troubleshooting, power off and restart to recover).</p>



NOTICE

If the unit is still out of function after you have taken step above, please contact after sales service by phone or e-mail.

7 Wiring Diagrams

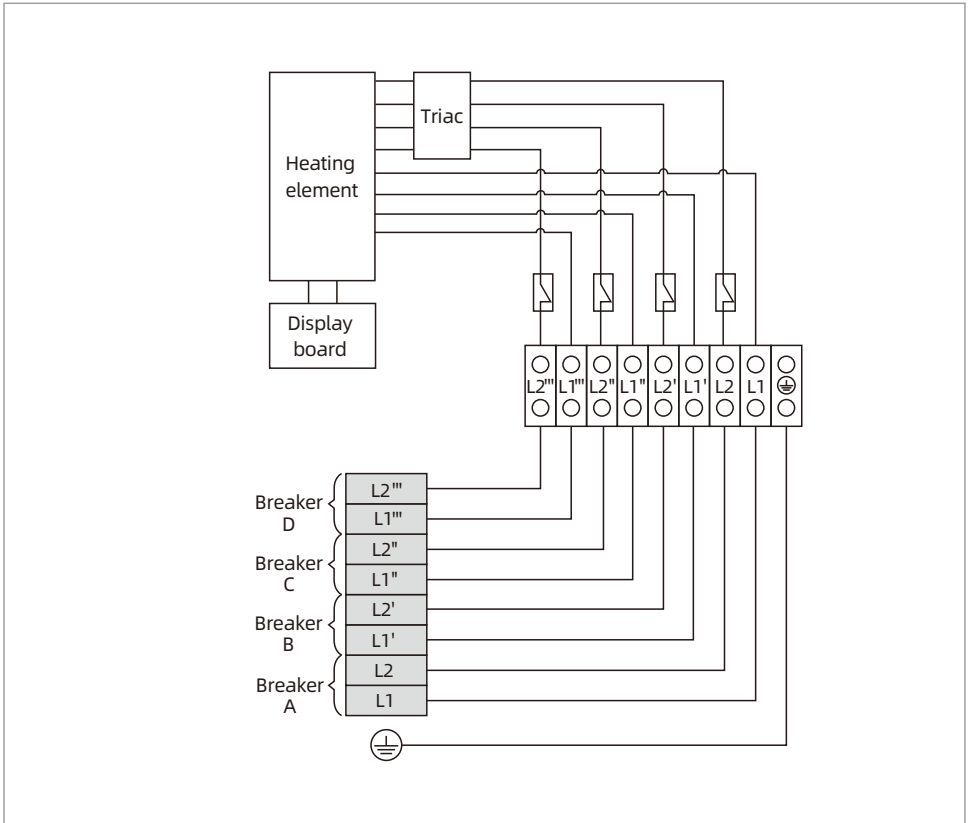

8 Packing List

Order	Design	Quantity
1	The water heater	1 piece
2	Installation and operation manual	1 piece
3	Installation guide	1 piece
4	Screw M4 × 20	4 pieces
5	Rubber plug	4 pieces
6	Inlet filter	1 piece
7	Rubber gasket for outlet and inlet	2 pieces

Warranty Policy

What is covered

The Standard Limited Warranty covers any defects in materials or workmanship when the product is installed and operated according to Mizudo written installation instructions, subject to the terms within this Limited Warranty document. This Limited Warranty applies only to products that are installed correctly in the United States and Canada. Improper installation may void this Limited Warranty. Mizudo strongly recommends that this tankless water heater to be installed by a contractor who is licensed, state qualified, and trained on Mizudo's tankless products since improper installation may invalidate warranty coverage.

How long does coverage last

Item	Period of Coverage (from date of purchase)
	Residential Applications
All Other Parts and Components	12 months
*Shipping Costs	30 days

* Excluding Alaska, Hawaii, and any location outside of the continental US and Canada

Limitation on warranties

During the Warranty Period, all repair parts must be genuine Mizudo parts; all repairs or replacements must be performed by a qualified professional who is professionally trained to do the type of repair. A component in the product fails because of a manufacturing defect, Mizudo will repair, replace, or refund the product to the owner at Mizudo's sole discretion and as determined to be appropriate by the Mizudo Support Team.

Mizudo does not authorize any person or company to assume for it any obligation or liability in connection with the replacement of the product. If Mizudo determines that repair of a product is not possible, Mizudo may replace the product with a comparable product at Mizudo's sole discretion. The warranty claim for product parts and labor may be denied if a component or product returned to Mizudo is found to be free of defects in material or workmanship; damaged by improper installation, use or operation; or damaged during return shipping.

No one is authorized to make any other warranties on behalf of Mizudo Corporation. Except as expressly provided herein, there are no other warranties, expressed or implied, including, but not limited to warranties of merchantability or fitness for a particular purpose, which extend beyond the description of the warranty herein. Any implied warranties of merchantability and fitness arising under state law are limited in duration to the period of coverage provided by this Limited Warranty, unless the period provided by state law is less. Some states do not allow limitations on how long an implied Limited Warranty lasts, so the above limitation may not apply to you. Mizudo shall not be liable for indirect, incidental, special, consequential, or other similar damages that may arise, including lost profits, damage to person or property, loss of use, inconvenience, or liability arising from improper installation, service, or use. Some states do not allow the exclusion or limitation of incidental or consequential damages, so the above limitation may not apply to you. This Limited Warranty gives you specific legal rights, and you may also have other rights which vary from state to state.

How To Obtain Service

To make a warranty claim through this Limited Warranty, the owner must contact Mizudo's Customer Service team at us.mizudo@fogatti.com, schedule a call or live chat on the Mizudo Whatsapp. It is within Mizudo's sole discretion when a repair, replacement, or refund will be issued. Any return for refund must be approved by Mizudo's Customer Service team prior to shipping the product back to Mizudo. Please refer to Returning Your Product for Repair or Refund Policy provided with the Product.

Within the first 30 days of purchase, Mizudo will cover all ground shipping costs for warranty related issues in the US and Canada, excluding Alaska, Hawaii, and any location outside of the continental US and Canada. After the first 30 days of purchase, the owner is responsible for all shipping to Mizudo, regardless of reason or circumstance. Mizudo will cover the warranty related shipping costs when returning the product to the owner after repair/inspection. The method for warranty related shipping will be ground equivalent with the provider within Mizudo's sole discretion.

What information you will need for processing of your warranty claim:

- Proof of purchase
- Serial numbers
- Photos of the installation
- Photos of the damaged part (if there is one)

All shipments of any type of product coming to Mizudo for any reason must have a Return Goods Authorization ("RGA") number for any repairs to be made. Please contact Mizudo to obtain an RGA number prior to shipping anything to Mizudo. Failure to do so could result in loss of product. Mizudo will not be responsible for replacement due to loss or damage if above steps are not properly followed.

Any returns to Mizudo must be sent in the original packaging. If your returned product does not have the original packaging and/or is missing any of the components that came with the product, there will be a nonnegotiable 15% restock fee.

What Is Not Covered

The following exclusions apply to this Limited Warranty:

1. A repair, replacement, or refund will not be provided under this Limited Warranty unless the Product containing the defective component is properly installed and maintained according to Mizudo's Installation Manual and Use & Care Manual and in compliance with all applicable federal, state/province, and local laws, regulations, codes, policies, and licensing requirements. Any abuse, misuse, alteration, neglect, or misapplication of the product will void this Limited Warranty.
2. A repair, replacement, or refund will not be provided if the product is damaged by services performed by third party service providers other than Mizudo Systems.
3. Mizudo systems is not responsible for any expenses arising from labor services, including but not limited to, installation or removal services due to a warranty claim.
4. A repair, replacement, or refund will not be provided if the product is damaged because of improper installation, including sizing, length, elevation, condensation drainage, or inadequate airflow.
5. A repair, replacement, or refund will not be provided if the product is damaged because of improper use, including freezing within the unit or surrounding piping, incorrect sizing for the application, scale build up, or incorrect gas and/or water pressure.
6. This product shall not be used as a pool or spa heater. Use of the Product as a pool or spa heater shall be considered misuse and will void this Limited Warranty.

7. A repair, replacement, or refund will not be provided if the product is damaged by the use of non-potable, untreated or poorly treated well water, or water with high PH levels or hardness levels in excess of 12 grains per gallon (200 mg/L).

8. A repair, replacement, or refund will not be provided under this Limited Warranty if the original serial number on the product has been removed or altered in a way that causes the serial number to not be readily determined.

9. Mizudo will not pay increases in electricity for any reason whatsoever, including additional or unusual use of supplemental electrical heat.

10. Mizudo will not be responsible for any default or delay in performance under this Limited Warranty caused by any factor or contingency outside of its control.

The water heater		Serial number
Product name		
Product model		
Purchasing date		

MIZUDO
Comfort with Innovation

Tel: 877-216-1818 | E-mail: us.mizudo@fogatti.com

JAJ.07.01.0076