

DOSKO

M2961000AA.1

MODEL NUMBER: 337-13HC, 337-13H,
337S-13HC
620-20HE

SERIAL NUMBER: _____

Owner's Manual

Instructions for Operation, Maintenance

Stump and Root Grinder

337-13HC, 337-13H, 337S-13HC,
620-20HE

Your Dosko grinder is intended for outdoor-use only and can be used to remove many tree stumps and exposed root systems close to ground level. By moving the blade in sweeping movements laterally over the top and front of the stump, you can gradually grind it away. Make sure you completely read and understand this manual before using the grinder for the first time.

WARNING

READ and UNDERSTAND this manual completely before using the grinder! Failure to properly operate, and maintain this grinder could result in *serious injury or death* to the operator or bystanders.

All machines have hazards associated with their operation. This stump grinder has certain special hazards, which you must be aware of. As an operator or owner you have a duty to be aware of these hazards and know preventive measures to take to avoid them. When reading this manual pay particular attention to avoiding these hazards.

In particular, be aware of the following:

- Know location of buried electrical and other utility lines.
- Do not allow children or untrained adults to operate.
- Wear eye protection and other personal protection against flying rocks and debris.
- Check that cutter wheel teeth are secured, sharp and not missing.
- Do not operate if operator presence bar fails to stop engine upon release.
- Make sure no children or bystanders are within 75 feet (23 meters) of stump grinding operation.
- Protect cars, windows and other objects within 75 feet (23 meters) from flying debris.
- Be prepared for machine "kickback" when initially contacting the stump.
- Be aware of potential for carbon monoxide (CO) poisoning.
- Prevent fires/explosions from fueling.
- Do not attempt to perform adjustments, declog or clean unit while engine is running.
- Avoid burns from engine or hot exhaust.
- Avoid using in wet or icy conditions where falls may occur.

Details about these hazards are found throughout the manual and are summarized at the end of the manual under "Important Safety Information."

STOP!

ADD ENGINE OIL, FUEL & BATTERY: Your stump grinder comes fully assembled and requires only that you add engine oil to crankcase, fuel to tank, and a battery.

INSPECT COMPONENTS: Closely inspect to make sure no components are missing or damaged. See the "Receiving Your Unit" section for instructions on whom to contact to report missing or damaged parts.

Any Questions, Comments, Problems, or Parts Orders

Call your dealer or DOSKO Customer Service 1-800-822-0295 or 1-763-428-2237

Hazard Signal Word Definitions





	<p>This is the safety alert symbol. It is used to alert you to potential personal injury hazards. Obey all safety messages that follow this symbol to avoid possible injury or death.</p>
	<p>DANGER (red) indicates an imminently hazardous situation which, if not avoided, will result in death or serious injury.</p>
	<p>WARNING (orange) indicates a potentially hazardous situation which, if not avoided, could result in death or serious injury.</p>
	<p>CAUTION (yellow) indicates a potentially hazardous situation which, if not avoided, may result in minor or moderate injury.</p>
	<p>CAUTION (yellow) used without the safety alert symbol indicates a potentially hazardous situation which, if not avoided, may result in property damage.</p>

fig01453

Table of Contents

Part I. Introduction

About Your Grinder	4
Safety Decal Locations	5
Safety Decals	6
Transporting & Receiving:	
1. Receiving Your Unit.....	8
2. Towing Instructions	8
Machine Component Identification	9

Part II. Operation

Operation:	
1. Pre-Start Check List & Procedures	10
2. Starting the Grinder.....	13
3. Stopping Engine.....	14
4. Grinding Stump.....	15
5. Refueling.....	16
6. Storing Machine.....	17

Part III. Maintenance and Repair

Maintenance (To be done by owner or Rental Dealer)	20
1. Belt Tension Adjustment	22
2. Stop-Switch Adjustment	23
3. Setting Teeth	23
4. Schedule.....	25
Specifications	26

Part IV: Important Safety Information

Summary of Important Safety Information for Operation	27
Special Safety Information on Static Electricity	30
Parts Explosion	31
Wiring Diagrams	33
Assembly Instructions	36
Warranty	40
California Proposition 65 Information	42

About Your Grinder

Thank you for purchasing or renting your Dosko grinder!

Owner/Operator/Renter Training

Read and follow all instructions and safety precautions presented throughout this manual. A summary of important safety information can be found at the end of the manual. Keep this manual for reference and review. **If the owner of this unit is different than the operator, give a copy of this manual to any operator to read.**

Rental Companies

All persons to whom you rent/loan this grinder must have access to this manual and read it. Check the tube on the side of the unit to make sure a manual is inside. Advise all persons who will operate the machine to read it. You should also provide personal instruction on how to safely operate the grinder and remain available to answer any questions a renter/borrower might have. If videos are available, have renter watch training video.

Engine Instructions

For detailed Engine operation and maintenance information, always refer to the engine Owner's Manual furnished with the grinder.

Product Suitability

Before using, the user shall determine the suitability of this product for this intended use and assumes liability therein.

Your Dosko grinder can be used to remove many tree stumps and exposed root systems close to ground level. By moving the blade in sweeping movements laterally over the top and front of the stump, you can gradually grind it away. Never use a stump grinder for anything but grinding wooden tree stumps. The intended operating environment is -20°C to 40°C to 95% RH. This is representative of most outdoor conditions. Make sure you completely read and understand this manual before using the grinder for the first time. If you have any questions, contact your retail or rental dealer or Dosko Customer Service at 1-800-822-0295 or 1-763-428-2237.

▲ WARNING: Never attempt to cut on a slope exceeding 15°.

Exercise caution when cutting stumps on an incline, as the machine may shift or slide unpredictably. Never attempt to cut with the machine uphill or downhill from you as it may slide toward you or you may fall toward the machine. Cut only on a slope from the side. Never place, use, or move the stump grinder on a slope exceeding 15°.

Dosko is constantly improving its products. The specifications outlined herein are subject to change without prior notice or obligation. The purchaser and/or user shall assume liability for any modification and/or alterations of this equipment from original design and manufacture. Any alterations shall void warranty and CE Certification (where applicable).

Contact Dosko Customer Service at 1-800-822-0295 or 1-763-428-2237 for any questions about the appropriate use of this grinder or about optional accessories.

Warranty Registration

Please fill out and submit the warranty registration card so that we have your contact information for any future product literature or replacement parts you may need.

Safety Decal Locations

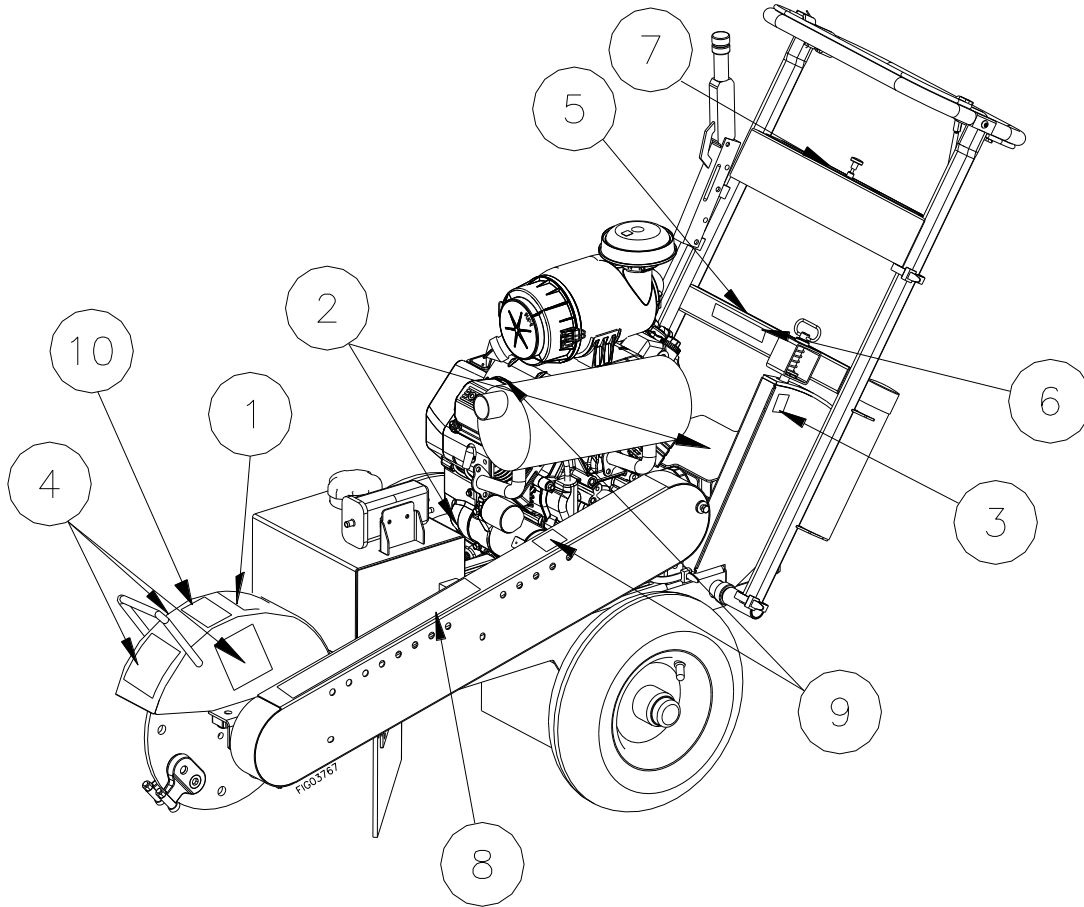

Reference #	Part #	Description	Model #
1	784272 decal kit	Flying Debris Hazard (person)	All
2	784291 789538	Flying Debris Hazard (direction) - located on base OR battery box top	All All (EU versions)
3	784079	Tow Position	All
4	784272 decal kit 789537	Amputation and Entanglement Hazard	All All (EU versions)
5	799546	California Proposition 65 Warning	All
6	784272 decal kit	Poisonous Gas Hazard	All
7	783540 784298 784299 789661 789663	Control Panel	337-13HC, 337S-13HC 620-20HE 357-13HE, 620-25KE 337-13H (EU version) 620-20HE (EU version)
8	784272 decal kit	Personal Injury / Fire, Explosion / Entanglement Hazards	All
9	786635	Burn Hazard - located on belt guard OR engine	All
10	799952	Spark-Strike Warning	337-13HC, 337S-13HC 620-20HE

WARNING

ALWAYS make sure safety labels are in place and in good condition. If a safety label is missing or not legible, order new labels.

Safety Decals

CAUTION		WARNING	
	Personal Injury Hazard Never attempt to service this machine without proper personal protection. When using this machine, you must wear the following: * Eye protection * Ear and hearing protection * Heavy duty work gloves * Heavy duty, non-slip footwear * Heavy duty, tight fitting clothing		Fire / Explosion Hazard Gasoline and oil are highly flammable. -NEVER fuel a running or hot engine. -KEEP sources of heat, sparks, and flame away during refueling. -ALWAYS turn engine off and let cool for at least two (2) hours before refueling. -Clean up fuel spills immediately. -Ensure there are no fuel leaks before starting. -DO NOT pump fuel directly into engine at gas station.
			Fire Hazard Hot exhaust fumes from engine can cause fire. Position muffler at least 7 feet from combustible objects, including vegetation and clothing. Do not change or add to exhaust system; fuel fire can result.
			Entanglement Hazard NEVER remove guards or shields. NEVER operate this machine when wearing loose cuffs or hoes. ONLY operate with proper guarding of power transmission system, including all rotating shafts, pulleys, belts, & couplings.

8

Precautions Before Starting...

1. Check gas and oil levels.
2. If unfamiliar with operation, training information (an Operator's Manual) can be obtained from your rental firm; you also have a video which demonstrates proper use.
3. Wear eye, face, and hearing protection as well as long pants and non-slip footwear.
4. Call 811 for utility marking 3 days before stump grinding. Trees can grow on top & around stump grinding object, even if removed many years before stump grinding.
5. Use proper stump grinding technique. Do not use power saw on tree stump. It should be operated only by an adult who has adequate physical capability.
6. Keep children away.

Replace worn or unreadable labels.

ENGINE SWITCH

PUSH TO STOP

PULL TO RUN

Special Operator Hazards...

1. Read & follow operator's manual before using.
2. Before adding fuel, stop the engine. Allow engine to cool for 30 minutes before refueling. Wipe up fuel spills immediately.
3. Do not touch the engine or gas system.
4. Blade rotator at speeds similar to a rotary lawn mower & will throw stones, chips, & debris up to 75 ft in any direction. Do not touch rotator or any object which might be damaged by the rock type projectiles this machine will throw.
5. Never operate without shields and covers in place.

To Start Your Stump Grinder...

1. Pull Engine Switch to RUN position.
2. For cold engine move choke lever to full choke position.
3. Grip Operator presence bar & handle together in left hand.
4. Turn the key switch to the START position and hold until the engine starts.
5. Release the key when the engine starts.
6. Release the key when the engine starts.
7. When engine starts, move choke lever to RUN position.

KEEP BRAKE ENGAGED

KEEP BRAKE ENGAGED

STOP engine & SET brake

before leaving operator's position.

7



WARNING

Poisonous Gas Hazard

This product gives off carbon monoxide, a poisonous gas that can kill you.

You CANNOT smell it, see it, or taste it.

- NEVER use in enclosed spaces, EVEN if you run a fan or open doors and windows.
- Only use OUTSIDE and far away from windows, doors, and vents.

See product manual for more details.

WARNING

FIRE HAZARD

-Sparks can occur if blade/rotor strikes rocks, metal or other hard objects.
-DO NOT use in highly flammable areas.
-Operation of this equipment may create sparks that can start fires around dry vegetation. A spark arrester may be required. The operator should refer to the operator's manual for information relating to fire prevention requirements.

10

5

WARNING

WARNING: This product can expose you to chemicals including soots, tars, and mineral oils, which are known to the State of California to cause cancer, and carbon monoxide, which is known to the State of California to cause birth defects or other reproductive harm. For more information go to www.P65Warnings.ca.gov.

PN 798546

WARNING

Flying Debris Hazard

WARNING

Flying Debris Hazard

*Some, chips, and debris can cause serious injury or property damage.
*Primary chip discharge is in the direction of the arrow.
*However, debris can fly 75 ft in any direction out the chute and bounce off objects and hit operator or bystanders.

Towing and Transport Position

WARNING

Amputation & Entanglement Hazard

Rotating Cutter

Keep hands and feet away.
Contact with rotating teeth will cause serious personal injury.
NEVER operate without guards and covers in place.

9

WARNING

BURN HAZARD

Do not touch hot muffler.

1

WARNING

Flying Debris Hazard

*Flying debris can travel up to 75 feet.
*Flying debris can also bounce off of this shield and hit nearby objects.
*NEVER allow anyone in DANGER ZONE while grinding.
*ALWAYS position machine to protect property (such as buildings and vehicles) from flying debris.
*Rubber shielding is intended to direct discharge to protect operator's lower extremities.
*Wear long pants and closed shoes, as well as eye and face protection.
*Replace if shielding is worn or damaged.

2

WARNING

Flying Debris Hazard

*Some, chips, and debris can cause serious injury or property damage.
*Primary chip discharge is in the direction of the arrow.
*However, debris can fly 75 ft in any direction out the chute and bounce off objects and hit operator or bystanders.

3

WARNING

Amputation & Entanglement Hazard

Rotating Cutter

Keep hands and feet away.
Contact with rotating teeth will cause serious personal injury.
NEVER operate without guards and covers in place.

4

To order replacement safety labels, call Dosko Customer Service at 1-800-822-0295 or 1-763-428-2237. All grinder units can be transported via trailers or with the purchase of an optional towing kit package can be towed behind the vehicle.

Safety Decals

Ref.	Description
A	Cutting hazard to foot. Keep distance.
B	Thrown object hazard. Keep distance.
C	Wear eye protection while operating.
D	Wear ear protection while operating.
E	Wear protective footwear while operating.
F	Wear gloves while operating.
G	Push to stop. Pull to run.
H	Hazards exist. Read manual before operating.
I	Move control forward to disengage brake. Move control backward to engage brake.
J	Pull to increase choke. Push to decrease choke.
K	Pull to increase throttle. Push to decrease throttle.

4 789537



A

2 789538



B

I

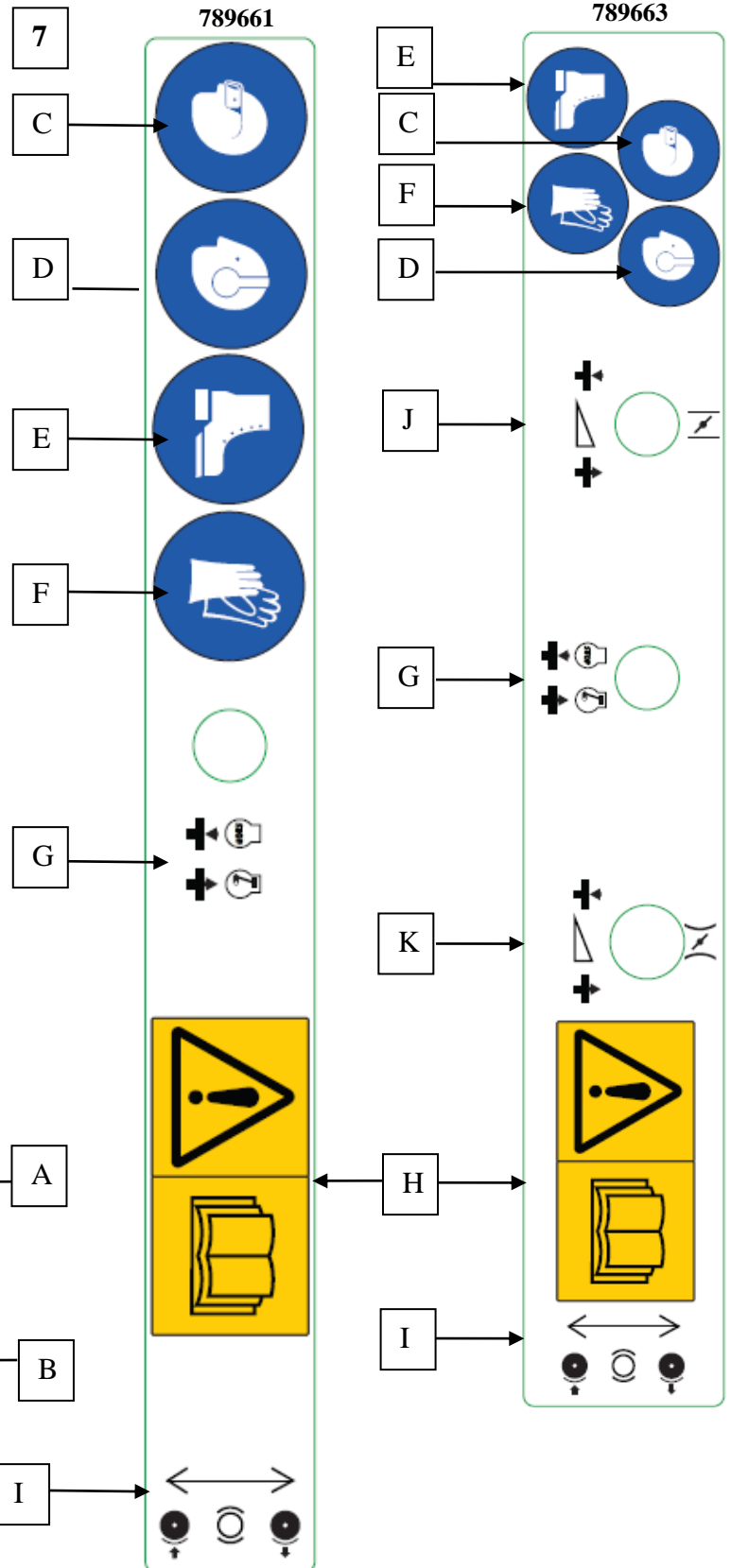

Transporting and Receiving

1. Receiving Your Unit

For all Units	<p>You should inspect the grinder immediately after you receive delivery. <i>See the “Machine Component Identification” section of this manual for a diagram of the grinder and its components.</i></p> <ul style="list-style-type: none"> • If you have <i>missing</i> components, contact your rental company or Dosko Customer Service at 1-800-822-0295 or 1-763-428-2237.
New Unit: Truck Delivery	<p>Depending on your unit and model, it may have been shipped on a wooden skid, cardboard container or other appropriate method.</p> <ul style="list-style-type: none"> ◆ For any shipping damage, make sure the delivery driver acknowledges it and a claim is filed with the freight delivery company. Note: <i>Shipping damage claims are not covered by Dosko warranty. Please contact carrier!</i> ◆ If any assembly is required. Separate assembly instructions will be included.
New Unit: From a Dealer	<p>Your unit may be completely assembled and ready to run depending on the dealer. If not, please refer to “factory delivery” below. Read the “<i>Operation: Preparing for Operation</i>” section (page 9), and verify that the unit has been properly “prepped” before initial use.</p>
Factory Delivery	<p>In these cases, your unit has been tested and pre-run but will require additional assembly. See “Assembly Instructions” section at the end of the manual.</p>

2. Towing Instructions

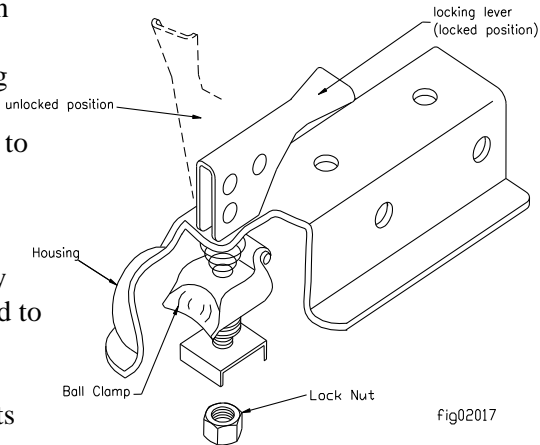
<p>On Towable Models</p> <p>Optional towing packages:</p> <p>Part # 296108 (337-13HC & 357-13HE)</p> <p>Part # 296107 (620-20HE & 620-25KE)</p>	<p>Each state has legal requirements for towing equipment and trailers (such as lighting and licensing). Be sure receiver on towing vehicle is bolted tightly. Towing vehicle capability must be matched to trailer weight and type of hitch arrangement.</p> <ol style="list-style-type: none"> 1. Review towing safety instructions in your vehicle manual. 2. Attach grinder to vehicle hitch using only a 2” ball. 3. Be sure the tow bar is bolted tightly to the towing vehicle receiver. 4. Position tow bar into socket, then insert lock pin with safety clip. 5. Be sure that the stump grinder safety chains are hooked, closed and locked to the towing vehicle by using the coupling links. 6. Make sure the grinder wheel lug nuts are fastened tightly, tires are fully inflated and in good repair. <div style="text-align: right; margin-top: 10px;">  <p style="font-size: small;">locking lever (locked position) unlocked position Housing Ball Clamp Lock Nut fig02017</p> </div> <div style="background-color: #e0e0e0; padding: 5px; margin-top: 10px;"> <p>⚠ WARNING: Do not tow over 45 mph unless a higher speed rated trailer is being used.</p> </div>
---	---

Machine Component Identification

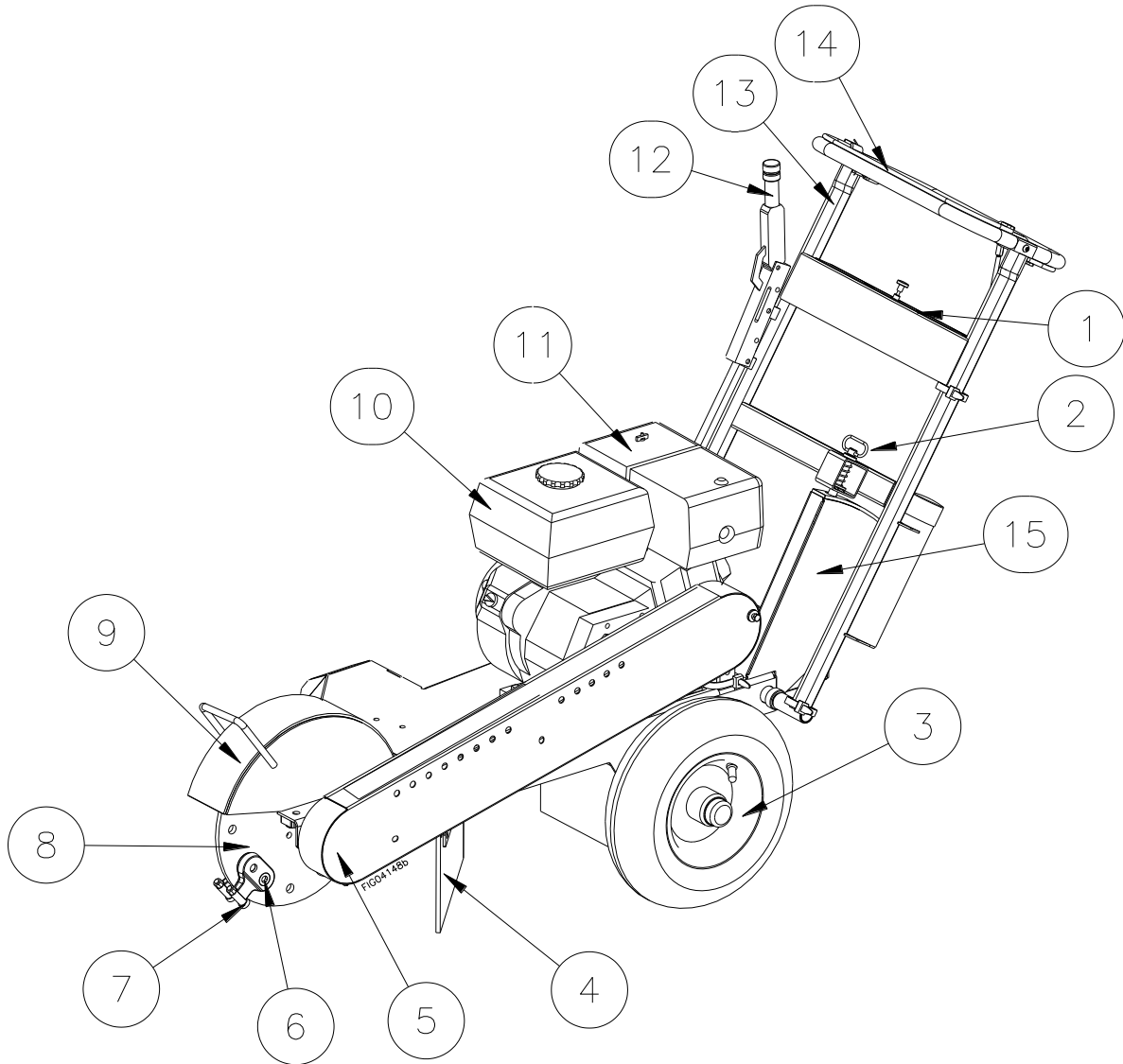

Reference #	Description
1	Control Panel
2	Pin Adjustment Handle Bar
3	Tire and Hub
4	Discharge Flap
5	Belt Guard
6	Tooth Pocket
7	Cutting Tooth
8	Cutter Wheel Disc
9	Cutter Guard
10	Gas Tank
11	Engine
12	Adjustable Brake Lever
13	Handle Bar
14	Operator Presence Handle Bar
15	Nameplate

Operation

1. Pre-start Check List & Procedures

⚠ CAUTION:

Add engine crankcase oil. A new engine is shipped without oil. You must add the correct amount of oil to engine crankcase or engine will be damaged beyond repair.

Before starting the engine you will want to make sure you have completed the following:

- 1. Marking Underground Utilities**
- 2. Checking Controls**
- 3. Checking/Adding Oil**
- 4. Filling Stump Grinder Gasoline Tank**
- 5. Inspecting Fuel System for Leaks**
- 6. Adjusting Handle Bar**
- 7. Wearing Personal Protection**
- 8. Trimming Stump with Saw**
- 9. Clearing Area of People and Objects**
- 10. Working During Daylight**
- 11. Battery Installation**

Each of these procedures is discussed in detail below.

Marking Underground Utilities	Call 811 or your local utility company to request marking utilities 3 days before stump grinding to verify location of underground wiring and piping. Trees can grow on top of and around underground wiring that was installed many years before a tree was planted.
Check Controls.	<p>Check that:</p> <ul style="list-style-type: none"> • All guards are in place and tight • Operator presence bar switch is free moving. • Inspect tires and rims for looseness, damage, and tire inflation.
Check Cutting Teeth	Inspect cutting teeth for tightness and sharpness. Only use factory-approved parts for repair.
Check/Add Oil	<p>Check the oil level using the dipstick and add oil as needed daily.</p> <p>Using a funnel, add oil up to the FULL mark on the dipstick with the recommended oil type for your engine and expected ambient conditions. (See engine Owner’s Manual for oil type and capacity, and more detailed oil check/fill instructions.)</p> <p>⚠ WARNING: Burn hazard Never open oil fill port while engine is running. Hot oil can spray over face and body.</p>

Operation (cont'd)

<p>Fill Stump Grinder Gasoline Tank</p>	<p>Check the gasoline level in the grinder's fuel tank. If needed, fill tank with fresh unleaded gasoline from a portable container, after first reading the warnings and instructions below.</p> <ul style="list-style-type: none"> - Do NOT fill the gas tank to the top. Gasoline may spill when operating on a slope. - Do NOT overfill the gasoline tank. Allow at least 1" (2.5 cm) of empty space below the fill neck to allow for fuel expansion. <p>▲WARNING: Gasoline fire/explosion hazard Gasoline is highly flammable and explosive. Heat, sparks, and flames can ignite gasoline vapors, which can become widespread during fueling. A flash fire ignition and/or explosion could result and cause serious injury or death. The following conditions could result in gasoline ignition/explosion:</p> <ul style="list-style-type: none"> • gas vapor collection inside enclosures • static electric sparks • sparks from electric wiring, batteries, or running engines • sources of heat (such as a hot engine or exhaust) • open flames, including pilot lights
<p>Inspect Fuel System / Check for Leaks</p>	<p>Inspect fuel system & check for leaks BEFORE starting grinder.</p> <p>▲WARNING: Fuel leak hazard A leaking fuel line no matter how small can be the source of a fire or explosion when starting or operating the engine.</p> <ul style="list-style-type: none"> • Inspect the entire fuel system. <i>Look for:</i> Signs of leaks or deterioration, chafed or spongy fuel hose, loose connections, loose or missing fuel hose clamps, damaged gasoline tank, or defective gasoline shut-off valve. <p>If grinder is in an enclosed area and you smell gas, DO NOT start engine! DO NOT light a match. DO NOT flip on an electrical switch. Exit area immediately leaving doors open and call fire department.</p>
<p>Adjust Handle Bar</p>	<p>Handle bar may have to be adjusted to accommodate for the height of stump or desired depth. When grinding above or below ground level, adjust handle bar for better control and comfort. <i>Note: Your stump grinder should not be used more than 10 inches (25 cm) maximum below ground.</i></p>
<p>Personal Protection</p>	<p>Use approved protective clothing and approved protective equipment when using the machine.</p> <ol style="list-style-type: none"> 1) Always wear ANSI-approved and OSHA-compliant (in the EU, EN166 1F) safety glasses with side shields and a full-face shield. 2) The use of ear plugs or other hearing protection device is also recommended for persons working within 15-20 feet (4.5–6 m) of the running grinder for longer than a few minutes. Hearing can be damaged from prolonged, close-range exposure to the type of noise produced by this grinder. 3) Wear long pants to protect legs from sparks, hot engine and flying debris.

Operation (cont'd)

	4) Never wear jewelry or loose-fitting clothing when starting or operating the grinder or any mechanical device. Loose or dangling apparel, jewelry or hair can become entangled in moving parts.
Trim Stump with Saw	Cut or trim the stump preferably to ground level using a power saw.
Clear Area	Dig away the earth and remove any stones near the tree stump or roots that may interfere with your work.
Work During Daylight Hours	Only use the machine in daylight or in well-lit conditions. Never operate the grinder after dark. Never operate the grinder in icy conditions, when there is severe weather, or lightning.

Battery Installation

Your stump grinder's engine is equipped with an electric starter (depending on model), which requires the installation of a 12-volt lawn tractor size battery (Group U1). See the Engine owner's manual for battery rating.

The battery is to be supplied by the customer and should be installed in the protective battery box located near the engine. (The inside dimensions of the battery box are 9" (22.5 cm) L x 6" (15 cm) W x 8-1/2" (21.5 cm) H). A battery hold-down strap has been supplied along with (2) 5/16 x 3/4" bolts and (2) 5/16" nuts in order to secure the battery inside the battery box. Follow the instructions detailed below for connecting and disconnecting the battery.

WARNING: Battery hazards

- Batteries are hazardous because they contain caustic acid, can emit explosive gases, and can cause electric shock. Caution must be exercised when making connections to a battery to avoid shock and contact with the acid, and to prevent any sparking that could lead to an explosion.

- ALWAYS follow the general battery safety rules and instructions listed below.

General Battery Safety Rules

- ALWAYS use eye protection when handling batteries.
- NEVER smoke or work near sparks or other sources of ignition.
- NEVER touch both battery terminals at the same time with your hand or any non-insulated tools.
- If battery acid contacts skin or clothing, flush immediately with water and neutralize with baking soda.

Connecting the battery

- Always connect the cables in the following sequence to avoid possible shock:
- Find the battery cables located inside the battery box.
 - Connect the **red** cable to the **positive (+)** terminal of the battery.
 - Then connect the **black** cable to the **negative (-)** terminal of the battery.

Disconnecting the battery

- Always disconnect cables in the following sequence to avoid possible shock.
- First, disconnect the **black** cable from the **negative (-)** terminal of the battery.
 - Next, disconnect the **red** cable from the **positive (+)** terminal of the battery.

Operation (cont'd)

2. Starting the Grinder

After you have completed the pre-start checklist and procedures, you are ready to start the grinder.

The following directions detail how to start the engine of your grinder.

▲ WARNING:

Never attempt to use the grinder without proper protective equipment, particularly eye protection and a full-face shield.

▲ WARNING:

If you have an implanted medical device, consult a physician before using this device.

To start the grinder:

Note: For additional engine starting instructions see your Honda/Kohler engine manual.

- 1) Before starting you should raise or lower the handle bar to a comfortable position to accommodate the height of the stump you will be grinding.
- 2) Place stump machine into position with cutting blade near the front-top edge of the stump.
- 3) Using lever on handle to lock the one wheel brake.

Note: For tighter brake adjustment, turn knob on top of brake lever.

▲ WARNING:

Stay in the OPERATOR POSITION while actuating controls. Never leave grinder unattended.

- 4) Pull Engine Switch ON. (Some models may have an additional on/off switch located on the engine)

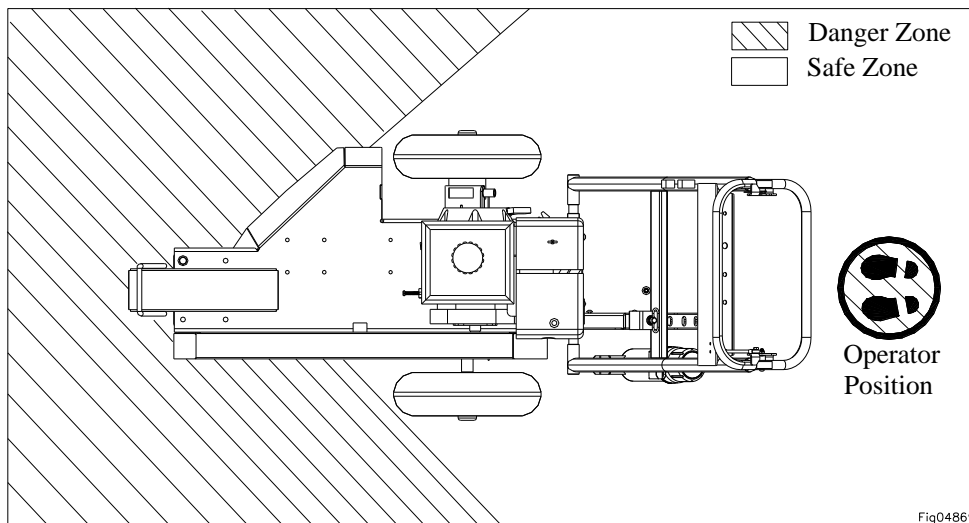

Operation (cont'd)

- 5) Pull choke if engine is cold. If engine is hot, do not use choke.
- 6) Grip operator presence bar & grinder handle bar together in left hand.

▲ WARNING:

A rotating cutting blade is very dangerous. Stay at the controls and keep others away until you are sure the blade has come to a complete stop.

▲ WARNING:

Cutting wheel immediately begins rotating when starter is pulled. There is no clutch or gear to separately start or stop cutter wheel.

- 7) Since the cutter wheel starts rotating when starter is activated, press down on handle bar to lift cutter wheel off the ground.
- 8) **A) Pull Start:** Rapidly pull “Start” cord (recoil starter) with right hand several times until engine starts. Allow starter cord to return slowly.
B) Electric Start: Turn Key switch to the START position and hold until the engine starts.
- 9) If engine does not start, repeat steps 5-8.

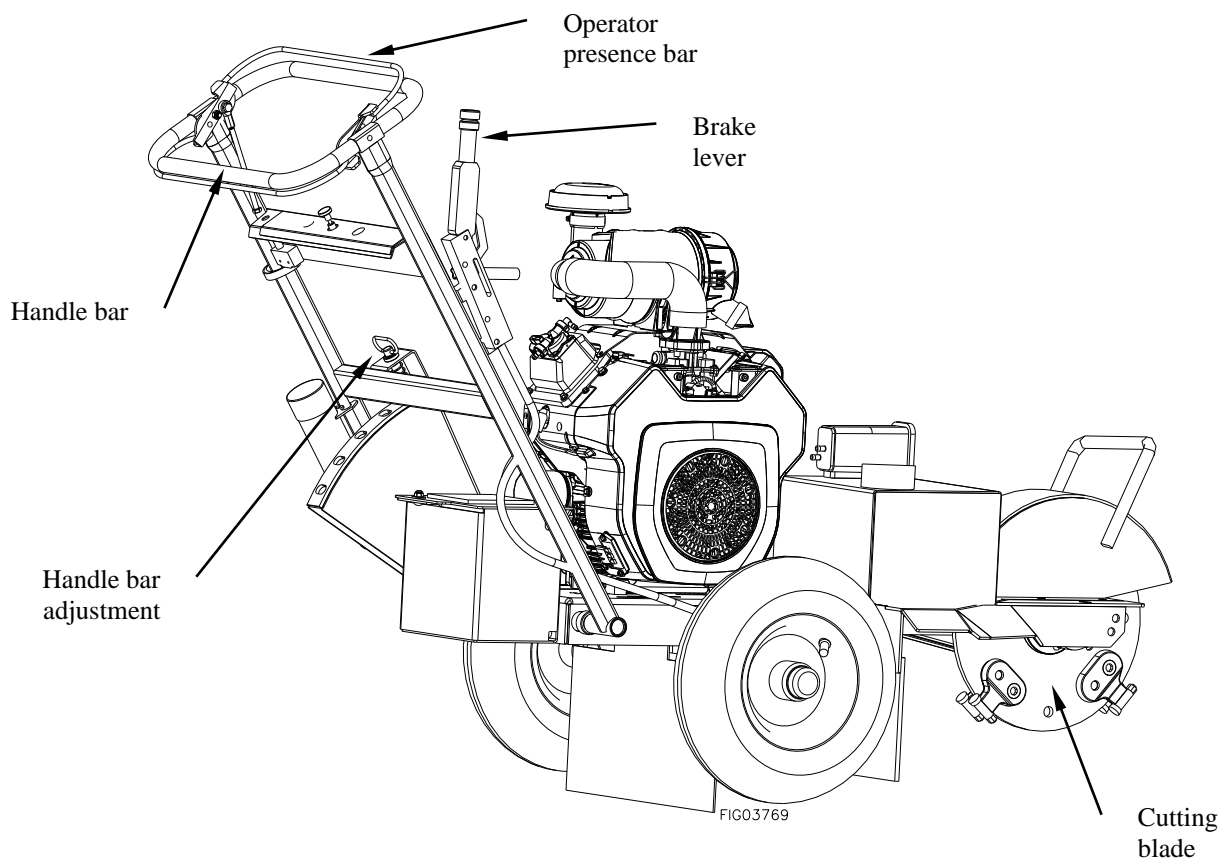

Operation (cont'd)

3. Stopping the Engine

Stop the engine using the following steps:

1. While holding blade off ground, release the operator presence bar. Wait until the blade completely stops. Lower the blade so it is resting against the ground.
2. Make sure brake is set before leaving the controls, particularly if you are on an incline.
3. Turn engine switch to OFF position.
4. Allow the engine to cool for at least 5 minutes before releasing brake and moving to storage or transporting. A hot engine can be a fire hazard.

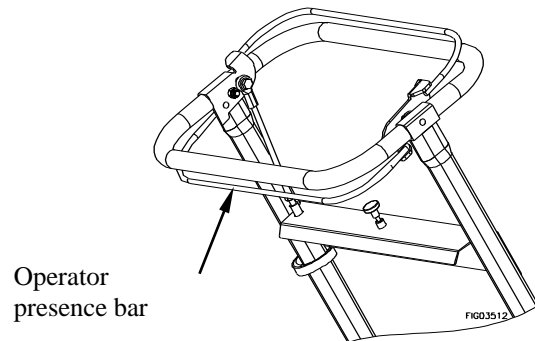

4. Grinding the Stump

▲ WARNING: Flying Debris Hazard

Stones, chips, and debris can cause serious injury or property damage. Debris can fly 75 ft (32 m) in any direction out of the chute. They can bounce off any fixed objects as well and hit operator, bystanders or breakable objects.

1. Set/engage the brake.
2. Pivot the grinder toward the side of the stump, then lower it approximately 1/2" (1.5 cm) to 1" (2.5 cm) into the front-top corner of the stump. Slowly pivot the cutting blade back and forth, lowering the cutting blade approximately 1/2" (1.5 cm) to 1" (2.5 cm) before each sweep, until you have removed the front portion of the stump to ground level.

▲ WARNING: Rotating cutter wheel.

Keep hands and feet away. Contact with wheel rotating teeth will cause serious personal injury.

3. Raise cutting blade until center of cutting blade is just above top of stump.
4. With cutting blade off to one side, advance the machine horizontally by releasing and resetting the brake. Advance the machine forward to engage the cutting blade into the stump so that when swept across the stump it will remove 1/2" (1.5 cm) to 1" (2.5 cm) of stump with each sweep.
5. Sweep the cutting blade across the stump, cutting away 1/2" (1.5 cm) to 1" (2.5 cm) of stump.
6. Advance cutting blade 1/2" (1.5 cm) to 1" (2.5 cm), and sweep again across stump in opposite direction.
7. Continue sweeping cutting blade left and right across stump, advancing it before each sweep, cutting 1/2" (1.5 cm) to 1" (2.5 cm) depth of stump with each sweep.
8. Cut complete stump flush with ground, then go back and cut to further depth, if desired.

Operation (cont'd)

Chip Build-up

9. When grinding larger stumps, chips may begin to build up under the wheels.
- Release brake and pull machine towards you so that the “chip pile” is directly under the cutting wheel.
 - Drop cutter wheel down on “chip pile”, material will be discharged from machine area.

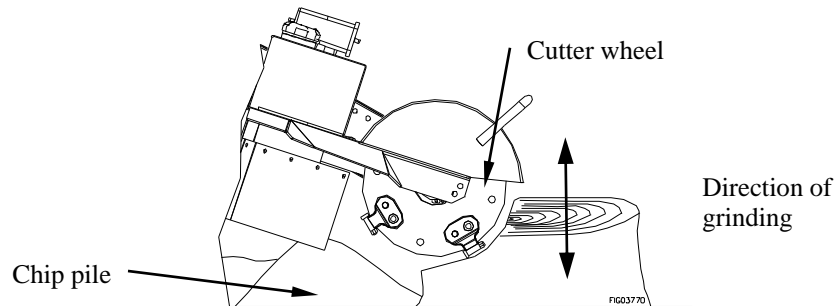

⚠ WARNING: Flying Debris Hazard

Stones, chips, and debris can cause serious injury or property damage. Debris can fly 75 ft (23 m) in any direction out of the chute and bounce off objects and hit operator, bystanders or breakable objects.

- On these larger stumps, **DO NOT** allow grinder wheels to drop into stump hole. If a hole is in the way of your progress, fill it with chips or change position.

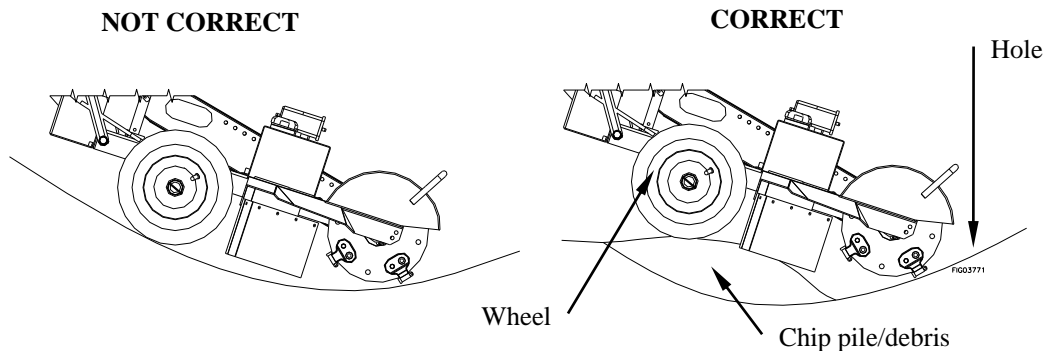

⚠ WARNING:

Stop engine and set brake before leaving operator's position. **KEEP BRAKE ENGAGED** except when changing locations. Never attempt to ride or stand on stump grinder.

10. When finished, stop the machine.
11. Pull machine away from stump, and rake chips away from stump.

Operation (cont'd)

5. Refueling

1) Before removing gas cap, turn engine off and allow to cool for at least two minutes.

Note: A running or hot engine can ignite fuel.

2) Remove grinder gasoline cap.

3) Add gasoline through the fill opening:

- Use only an UL-approved portable gasoline container to transfer the gasoline to the grinder's tank.
- Be aware of safety warning and instructions below for avoiding static electric caused fires.

⚠ WARNING:

Static electric spark hazard

A static electric spark can explosively ignite gasoline vapor, resulting in a flash fire that could cause serious injury or death. See "Special Safety Information on Static Electricity" at end of this manual.

4) Clean up gasoline spills /splashes immediately.

- If possible, move the grinder away from spilled gasoline on the ground.
- Wipe up spilled gasoline, and wait 5 minutes for excess gasoline to evaporate before starting engine.
- Gasoline soaked rags are flammable and should be disposed of properly.
- If gasoline is spilled on your skin or clothes, change clothes and wash skin immediately.

5) Replace gasoline cap securely before starting engine.

6) Store extra gasoline in a cool, dry place in an UL-approved, tightly sealed container.

7) Filling towable units or portable containers at service stations:

Even if you have a towable unit, avoid static electric sparking while filling the gasoline tank:

- Never fill the grinder's gas tank directly from the fuel pump. The grinder's tank is not grounded and high velocity flow from the pump can cause static electricity build-up. Use an approved portable container to transfer gas to the grinder's tank.
- Use a portable container made of metal or conductive plastic. This is preferred because it dissipates static charge to ground more readily.
- Never fill a portable gas container while it is sitting inside a vehicle, trailer, trunk, or pick-up truck bed. ALWAYS place container on the ground to be filled.
- Keep nozzle in contact with container while filling. Do not use a nozzle lock-open device.

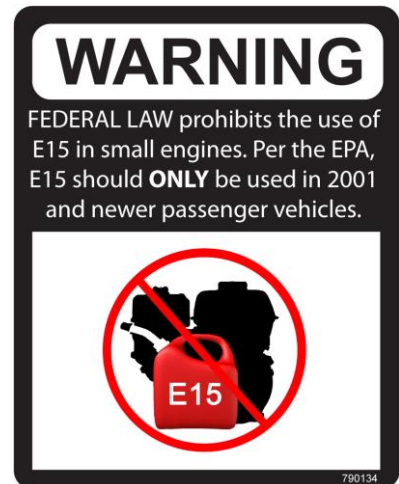

Operation (cont'd)

6. Storing the Grinder

When you are finished using the grinder and it has cooled, you must:

- Cool engine before storage.
- Clean the grinder.
- Inspect for worn or damaged parts.
- Choose covered storage location.
- Prevent accidental starting.
- Plan on exercising the engine at least monthly unless the grinder is prepared for long-term storage.

Detailed instructions are provided below.

Cool engine	Let engine cool for at least five minutes before storing. A hot engine can be a fire hazard.
Clean grinder	Clean all grease, dirt, mud and other foreign matter from the machine. Touch up paint damage to prevent rust.
Inspect grinder	Inspect the machine for worn or damaged parts and tighten any nuts or screws that may have become loose. Pay particular attention to the cutting teeth.
Choose a storage location	<p>Store the grinder in a location that is:</p> <ul style="list-style-type: none"> • Clean and dry. • Away from sources of heat, open flames, sparks, or pilot lights, even if the grinder's gas tank is empty. Residual gasoline could ignite. • Away from extreme high or low temperatures. • Cover it for extra protection. <p>⚠WARNING: If stump grinder is left in direct sunlight and exposed to extreme temperatures fuel hoses can degrade rapidly.</p>
Remove key	Remove key from starter and secure key in a safe location, or remove spark plug, in order to ensure the grinder cannot be started in a storage location or by untrained persons or children.
Start grinder every 4 weeks	<p>The grinder should be started regularly. At least every four weeks, start the engine and let it run for 10 to 15 minutes.</p> <p>Monthly exercising of the grinder will dry out any moisture that has accumulated, lubricate cylinders, and clean out old gas in the carburetor. Moisture, old gas, and dry mechanical parts cause deterioration in stored engines.</p>

Operation (cont'd)

Prepare engine for long term (seasonal) storage if needed

If you will not be able to start the grinder regularly, you must prepare the engine for long term storage to prevent gum deposits from forming and causing malfunction of the engine.

Prepare engine for long term storage by:

- **Removing all gasoline** from the tank and carburetor
- OR
- **Adding fuel stabilizer** to the gasoline (following manufacturer's instructions)
 - Fuel stabilizer steps:
 - 1. Ensure gas tank is full.
 - 2. Add fuel stabilizer to fuel tank.
 - 3. Run engine at least 10 minutes after adding stabilizer to allow it to enter the fuel system.
 - 4. Shut off engine
 - 5. Disconnect spark plug wire and remove spark plug
 - 6. Add one teaspoon oil through spark plug hole
 - 7. Place rag over spark plug hole and turn starter (or pull the recoil) a few times to lubricate the combustion chamber.
 - 8. Replace spark plug, but do not reconnect the spark plug wire.

▲ WARNING: Gasoline fire/explosion hazard

Gasoline is highly flammable and explosive. Drain the fuel into an approved container OUTDOORS and far away from open flame. NEVER store an engine with fuel in the tank indoors or in poorly ventilated spaces where fuel vapor can come in contact with

- static electric sparks
- sparks from electric wiring, batteries, or running engines
- sources of heat (such as a hot engine or exhaust)
- open flames, including pilot lights

Maintenance & Repair

⚠ WARNING

ALWAYS shut off the engine, make sure the engine is cool, disconnect the spark plug and positive battery terminal from the battery before cleaning, adjusting, or servicing the grinder. Make sure all guards and shields are replaced before using.

Maintenance	
Perform regular maintenance	Perform periodic maintenance as directed in this manual to keep the grinder in safe working condition.
Follow safety rules	<p>Read and follow these safety rules whenever you will be servicing the grinder:</p> <ul style="list-style-type: none"> • Turn off grinder. Always turn off grinder and remove spark plug or spark plug wire, and disconnect positive battery terminal from battery on electric start models before working on the engine or grinder to prevent accidental starting. • Replace guards/shields. Make sure all guards and shields are replaced after servicing the grinder. • Burns. Muffler will be hot even after unit is stopped. Allow unit to cool before servicing. • Repair. Major service, including the installation or replacement of parts, should be performed only by a qualified electrical service technician. Obtain factory approved parts from Dosko Customer Service at 1-800-822-0295 or 1-763-428-2237. • Replacement parts. If a part needs replacement, only use factory approved repair parts. Replacement parts that do not meet specifications may result in a safety hazard or poor operation of the grinder and will void the warranty and CE certification.
Perform engine maintenance	<p>Perform engine maintenance as specified in the engine owner's manual.</p> <p>Engine maintenance items include:</p> <ol style="list-style-type: none"> 1. Oil and oil filter changing 2. Air filter check/replacement 3. Spark plug cleaning and replacement 4. Fuel filter check/replacement 5. Fuel tank cleaning.
Inspect fuel system / check for leaks	<p>Inspect the fuel system and check for leaks on a regular basis.</p> <p>Look for: signs of leaks or deterioration, chafed or spongy fuel hose, loose connections, loose or missing fuel hose clamps, damaged gasoline tank, or defective gasoline shut-off valve.</p>
Lubricate	<p>Cutter shaft bearings and wheel bearings should be greased.</p> <p>The cutter shaft bearing is greased by pumping grease into zerks located on the housing of the bearing.</p>

Maintenance & Repair (cont'd)

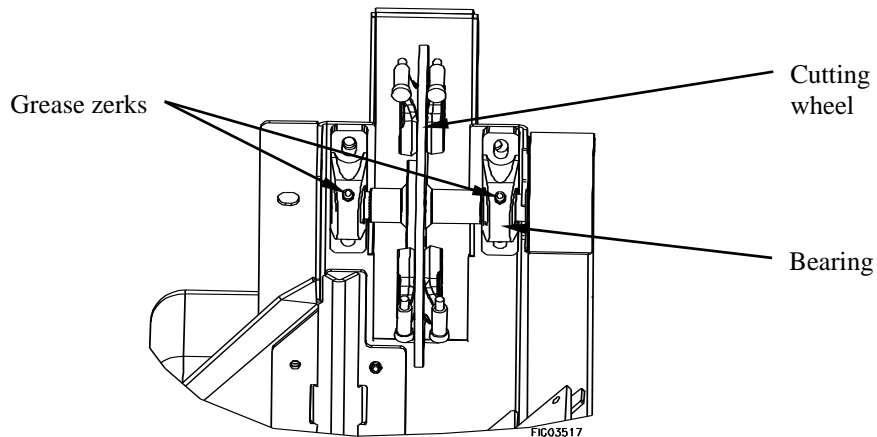

The wheels should be greased by repacking the bearings inside the wheel hub with grease.

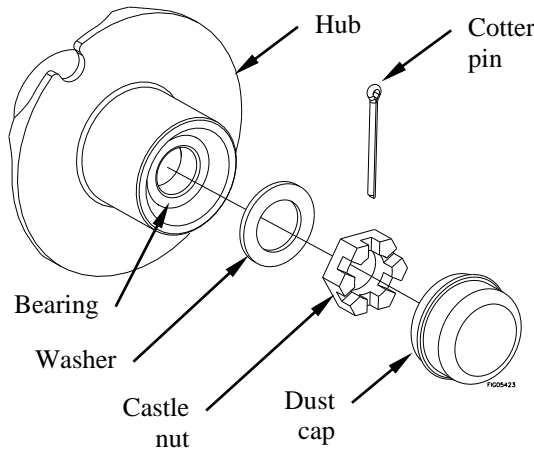

1. Remove existing cap, cotter pin, castle nut, washer, and hub off spindle.
2. Inspect inner and outer bearing and pack with grease.
3. Slide hub and washer back onto spindle.
4. Using a torque wrench, tighten the castle nut 30-40 ft-lbs (40-54 Nm).
5. Loosen the castle nut until loose enough to turn the castle nut with your fingers.
6. Re-tighten the castle nut finger tight.
7. Reinstall cotter pin and dust cap.

Grease Specification	
Soap Type	Lithium Complex
NLGI Grade	#2
Dropping Point	230°C (446°F)
Additives	Corrosion and Oxidation inhibitors, EP optional
Viscosity Index	80 Minimum

Check and adjust brake

Check that the brake is functioning properly.

- Lock the brake, push down on handle bar so that cutter wheel is off the ground.
- Push or pull the grinder- if the brake is loose, the wheel will rotate.

Maintenance & Repair (cont'd)

To adjust braking tension (all models except 337S):

- Unscrew set screw.
- Turn knob clockwise to increase tension or counter-clockwise to decrease tension.
- Once you have set the brake to the proper tension, tighten set screw to lock adjustment knob.

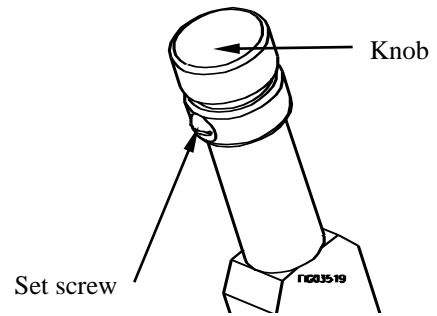

Clean & inspect spark arrester (instructions for 620-20HE only)

Clean and inspect the spark arrester on muffler

If the engine has been running, the muffler and spark arrester will be hot. Allow those to cool before servicing the spark arrester.

Tools needed: Wire brush and Philip's head screwdriver

1. Remove the securing screw from the side of the spark arrester (located on the exhaust output pipe on the muffler).
2. Slide the spark arrester off the exhaust pipe.
3. Inspect the spark arrester mesh (screen). Replace spark arrester if mesh (screen) is damaged.
4. Use a wire brush to lightly remove the carbon deposits from the spark arrester mesh (screen). Be careful to avoid damaging the mesh (screen).
5. Slide the spark arrester over the exhaust pipe and align the spark arrester hole to the exhaust pipe hole at the 3 o'clock position.
6. Secure the spark arrester using the supplied screw.

Belt Tension Adjustment

Note: Belt tension and alignment are inter-related. Do not adjust one without checking the other.

1. Remove belt guard.
2. Loosen (4) engine bolts.
3. With long socket extension drive, move engine forward with rear adjusting bolt.
4. When belt tension is proper 11 to 14 ft/lbs (15 to 19 Nm) of tension, or 3/16" (5 mm) deflection, retighten all loosened bolts.
5. Reassemble belt guard.

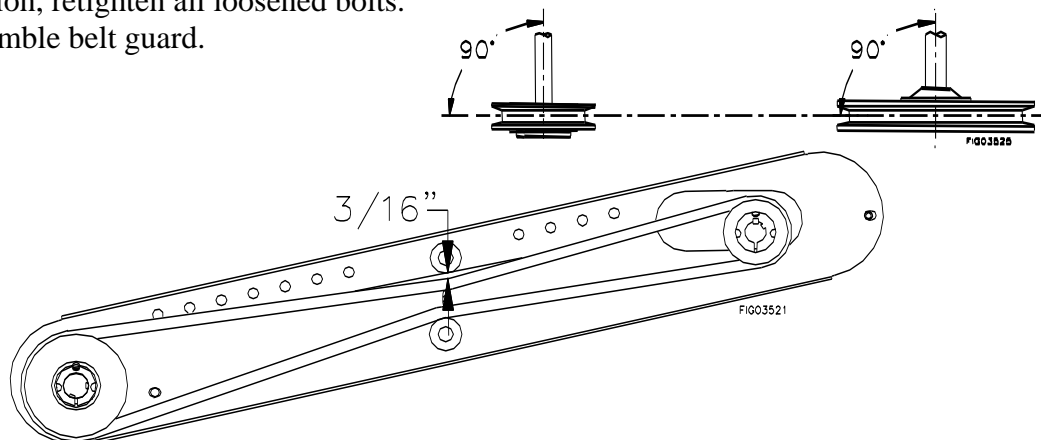

Maintenance & Repair (cont'd)

Note: New belts require a “break-in” period of approximately 10 hours. Readjustment may be necessary after “break-in.”

Note: Use only factory recommended belts. Contact your Dosko dealer.

Stop-Switch Adjustment

⚠ CAUTION:

Never attempt to alter, modify or override this switch.

If Stop-switch ever needs to be replaced or adjusted follow the below directions.

1. Loosen Hex Nut.
2. Turn the Linkage Bolt clockwise to lower or counter-clockwise to raise the point of interaction with Stop Switch. To set the proper interaction distance, grip the Operator Presence Bar & Handle Bar together and lower the Linkage Bolt onto the Switch Button until the switch button cannot be depressed any further. Then raise the linkage bolt one turn (counterclockwise).
3. Tighten Hex Nut.
4. Verify operability of stop switch before operating machine by releasing the operator presence bar next to the handle bar. You should hear a “CLICK”, signifying that the Linkage Bolt has been adjusted properly.

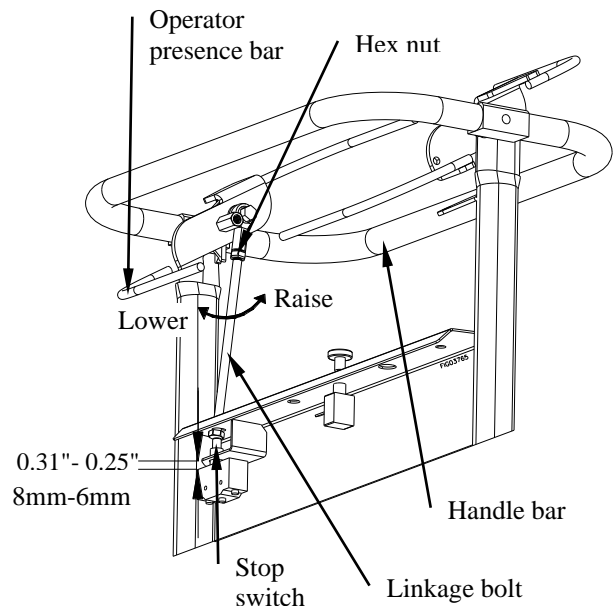

Setting Teeth

Among the most critical elements of the stump grinder is the cutting blade. It is also the most subject to damage and wear. In the course of grinding stumps it not only makes contact with the wood, but also encounters numerous abrasives and objects in the stump’s environment, such as dirt, stones, large rocks and buried scrap.

The loss and wear of cutting teeth can significantly impair the efficiency and performance of the stump grinder. Therefore, it is important to make frequent inspections of the condition of all the cutting teeth and to sharpen or replace any damaged or worn teeth. Sharpening the teeth before excessive wear will result in longer lasting teeth and better performance.

Setting Teeth

Installing pockets

1. Locate the straight teeth and pockets on your wheel.
2. Remove one set of straight teeth and pockets.
3. Clean this area with a wire brush.
4. Start with a counterbored pocket. Counterbored pockets have non-threaded big holes. They go on the right-hand side of the wheel as you face the wheel.

Maintenance & Repair (cont'd)

- Install two low-pro pocket bolts into the counterbored pocket holes.
5. Apply anti-seize onto the threaded position of the low-pro pocket bolt.
 6. Slide the counterbored pocket and low-pro pocket bolts through the holes in the wheel from the right side and thread them into the threaded holes in the threaded pocket. Firm up the low-pro pocket bolts until pockets are firm on the wheel. Do not tighten then down yet.
 7. Rotate the wheel until you come to the next set of straight teeth.
Repeat steps 2 – 6.
 8. Next, replace the angle pockets (angles curve away from the wheel).
 9. Remove one set at a time or all old angle teeth and pockets at once. Clean the wheel with a wire brush.
 10. Install your low-pro pocket bolt through the holes in the counterbored pocket. Apply anti-seize. Slide the low-pro pocket bolts through the holes in the wheel. Make sure the counterbored pocket is on the right hand side of the wheel. Insert the low-pro pocket bolts into the threaded pockets and tighten the pockets firmly onto the wheel. Repeat this step until all your standard angles pockets are installed.

Installing teeth

1. If all the counterbored pockets are on the right hand side of the wheel, your tooth will go into your pocket properly. If your pockets are mounted upside down, the teeth will have a tendency to spin freely or be sloppy in the pocket. You will know this by looking at them.
2. Install your teeth with the carbide facing down. The shoulder of the tooth will meet the flat detent of the pocket and the tooth will not rotate. Thread nut onto the top portion of the tooth. Hand tighten for now. Repeat until all teeth are installed.

Torque

1. Torque the low-pro pocket bolts to 180 – 240 ft lbs (245 – 325 Nm).
2. You will notice the slotted end of the low-pro pocket bolt is about 1/8" (3 mm) short of the end of the threaded pocket. This is okay. This area will fill with dirt and protect the extraction slot at the end of the low-pro pocket bolt. If you need the slot, clean out the packed dirt and use the slot to turn out the broken bolt.
3. To torque your tooth down, tighten the top lock nut to 20 ft-lbs (27 Nm), until the tooth is firmly seated. Double check that the tooth is firmly seated. Do not over tighten. Over tightening the nut will stretch the threads and make it impossible to ever tighten again.
4. Once the low-pro pocket bolts, teeth and nuts are seated and torqued properly, cut a few stumps. Recheck bolts and nuts to make sure they are tight and secure. Recheck frequently for the first week of use and once a week thereafter.

When you dull or damage a cutting edge, loosen the top nut, tap the tooth down, rotate the tooth a third of a turn and tighten back up.

Maintenance & Repair (cont'd)

Maintenance Schedule

⚠ CAUTION:

Before attempting any maintenance, be sure that the engine is shut off, the key, the positive battery cable, and both spark plug wires are removed, and the engine is cool to the touch!

Item (What to check or action req'd)	Daily	Each Use	10 hours	20 hours	40 hours	2x/year
Bearings, Shaft - Grease				X		
Bearings, Wheel - Grease						X
Belt Tension - Tension					X	
Bolts - Tightness			X			
Engine – See manual						
Gasoline – Amount		X				
Safety Switches – Operation		X				
Warning Decals – Legible	X					
Tires, Flaps – Condition	X					
Wires, Cables – Condition		X				
Cutter Teeth - Sharpness		X				

Safety switch and relay (equipped models only) should be replaced after 7 years of use.

IMPORTANT:

If a part needs replacement, only use parts that meet the manufacturer's specifications. Replacement parts that do not meet specifications may result in a safety hazard or poor operation of the grinder.

**Contact Dosko Customer Service at 1-800-822-0295 or 1-763-428-2237
for any questions, problems, or parts orders.**

Specifications

	337-13HC	337S-13HC	337-13H	620-20HE
ENGINE OPTIONS				
Make	Honda	Honda	Honda	Honda
Model	GX390UT2QXC9	GX390UT2QXC9	GX390UT1QAA2	GX630RTXF2
CC Rating	390 cc	390 cc	390 cc	630 cc
GENERAL				
Weight	300 lbs. (136kg)	380 lbs. (136kg)	300 lbs. (136kg)	400 lbs (181kg)
Length	58" (147cm)	58" (147cm)	58" (147cm)	58" (147cm)
Height	51" (130cm)	51" (130cm)	51" (130cm)	51" (130cm)
Width	32" (81 cm)	32" (81 cm)	32" (81 cm)	32" (81 cm)
RPM Operating	3600 RPM	3600 RPM	3600 RPM	3600 RPM
Type of Fuel	Gasoline	Gasoline	Gasoline	Gasoline
Starting	Recoil	Recoil	Recoil	Electric
Oil Sensor	Yes	Yes	Yes	Yes
CUTTER WHEEL				
Diameter	14" (36cm)	14" (36cm)	14" (36cm)	14" (36cm)
Thickness	3/8" (.95cm)	3/8" (.95cm)	3/8" (.95cm)	3/8" (.95cm)
Bearings(Dia.)(2)	1-3/16" (3cm)	1-3/16" (3cm)	1-3/16" (3cm)	1-3/16" (3cm)
Teeth Pockets	Reversible	Reversible	Reversible	Reversible
Teeth (8) (Carbide Tips)	Greenteeth®	Greenteeth®	Greenteeth®	Greenteeth®
	3/4" dia. (1.9cm)	3/4" dia. (1.9cm)	3/4" dia. (1.9cm)	3/4" dia. (1.9cm)
	1/4" thick (.635cm)	1/4" thick (.635cm)	1/4" thick (.635cm)	1/4" thick (.635cm)
Disc RPM	2200 RPM	2200 RPM	2200 RPM	2500 RPM
Drive	Direct Belt Drive	Direct Belt Drive	Direct Belt Drive	Direct Belt Drive
	1 banded Gates belt	1 banded Gates belt	1 banded Gates belt	1 banded Gates belt
	3 groove power band with idler bearing belt tensioners	3 groove power band with idler bearing belt tensioners	3 groove power band with idler bearing belt tensioners	4 groove power band with idler bearing belt tensioners
CUTTING CAPACITY				
Above Grade	20" (51 cm)			
Below Grade	10" (41 cm)			
Stump Diameter	No Limit			
GROUND TRAVEL				
Speed	Towable - Never Exceed 45 mph			
Drive	Wheel Hub			
	480 x 8" (480 x 20 cm)			
Brake	Wheel Hub with Adjustable Brake Band			
Opt. tow pkg.	337-357TP	N/A	337-357TP	620-TP
NOISE AND VIBRATION DATA				
Sound Pressure	94 dBA	94 dBA	94 dBA	92 dBA
Sound Power	104 dBA	104 dBA	104 dBA	102 dBA
Hand-Arm Vib.	4.32 m/s ²	4.32 m/s ²	4.32 m/s ²	4.43 m/s ²
Std. Deviation	0.80 m/s ²	0.80 m/s ²	0.80 m/s ²	0.75 m/s ²

Summary of Important Safety Information

This section provides a summary of the various safety procedures and measures that have been presented throughout the manual. Keep this summary handy and refer to it to refresh your memory about how to safely use your grinder.

WARNING

Carefully read and make sure you understand the following safety information before using the grinder. Improper use or maintenance of the grinder can result in ***serious injury or death*** from ***fire/explosion, carbon monoxide poisoning, lacerations, entanglement or burns***. Damage can also occur to windows, siding, vehicles, and bystanders from chips and debris which can become projectiles.

General

- **Read manual.** Read this Owner's Manual and the engine Owner's Manual completely before attempting to use and service the grinder. Serious injury or death can result if safety instructions are not followed.
- **Instruct operators.** The grinder owner or rental company must instruct all operators in safe grinder set-up and operation. Do not allow anyone to operate the grinder who has not read the Owner's Manual and been instructed on its safe use. Make sure Owner's manual is within the attached storage tube on the grinder.
- **Adults only.** Only trained adults should operate and service the grinder. Do not let children operate.
- **Under the influence.** Never operate, or let anyone else operate, the grinder while under the influence of alcohol, drugs, or medication.
- **Intended use.** Carefully read about and understand the intended use of this grinder. Do not use for other purposes, as unforeseen hazards or equipment damage may result.
- **Controls and safety labels.** Learn how to use the machine and its controls safely. Understand and follow all safety labels.
- **Weather.** Never use in foul, bad or questionable weather, which causes a slippery ground condition.

Prohibition Against Modifications

Never modify or alter the grinder in any way. Modifications can create serious safety hazards and will also void the warranty and CE certification.

- **Fuel/exhaust system.** Never modify the exhaust system, fuel tanks, or fuel lines. Carbon monoxide poisoning, fire, or explosion could result.
- **Guards.** Do not operate grinder unless all guards and cover shields, which prevent access to moving parts and pinch points, are in place. Failure to guard the power transmission mechanisms *may result in serious injury or death*.

Safety – Before Use

Know how to operate

- **Review safety rules.** Before use of this grinder, review the "Rules for Safe Operation." If you have an implanted medical device, consult a physician before using this device.
- **Know how to operate.** Be thoroughly familiar with all controls and with the proper use of the equipment. Know how to stop the grinder quickly if needed.
- **Utility marking.** Call 811 or your local utility company for utility marking 3 days before stump grinding. Trees can grow on top of and around underground wiring that was installed many years before a tree was planted.

Getting Ready

- **Flying debris.** Clear area of objects such as stones, toys, steel wire, etc. that could become caught in moving machine parts and ejected as a projectile.
- **Operate OUTSIDE only – dangerous carbon monoxide exhaust!** Grinders give off carbon monoxide exhaust, a poisonous gas that can kill. You CANNOT smell it, see it, or taste it. ONLY run grinder OUTDOORS and at least 20 feet (6 m) from the home, away from windows, vents and air intakes, to allow proper ventilation. If you start to

Summary of Important Safety Information (cont'd)

feel sick, dizzy, or weak while using the grinder, shut off the engine and get to fresh air RIGHT AWAY. NEVER run grinder engine inside homes, garages, sheds, or other semi-enclosed spaces. These spaces can trap poisonous gases.

- **Cooling ventilation.** The grinder needs adequate, unobstructed flow of air to allow for proper cooling of engine and grinder head. Do not allow debris to accumulate and block airflow.
- **Transporting.** During transporting, take precautions to make sure stump grinder will not tip over and cause a fuel leak hazard.
- **Hot exhaust - fires.** Exhaust from engine can be extremely hot and cause fire. Position muffler at least 7 feet from combustible objects during operation.
- **Fire extinguisher.** Keep a fire extinguisher rated “ABC” by the National Fire Protection Association nearby is always recommended when using gasoline operated machinery. Keep it properly charged and be familiar with its use.

Personal protective equipment

- **Hearing protection.** The use of ear plugs or other hearing protection device is recommended for those in close proximity to the grinder while it is operating.
- **Eye protection.** Wear ANSI approved (in EU, EN166 1F) eye protection when operating the grinder.
- **Face protection.** A helmet with a full-face visor or mesh visor with protective glasses is recommended.
- **Loose / dangling.** Loose or dangling apparel, jewelry or hair can become entangled in moving parts. Never wear jewelry or loose-fitting clothing when operating the grinder.
- **Long pants.** Wear long, heavy-duty pants to protect legs from ejected materials.

Gasoline Safety

Gasoline is highly flammable and explosive. You can be burned or seriously injured when handling fuel. Use extreme care when handling gasoline:

- **Fuel outdoors.** Fill fuel tank outdoors – never indoors. Gasoline vapors can ignite if they collect inside an enclosure. Explosion can result.
- **Use approved container.** Never pump fuel directly into engine at gas station. Static charge can build and ignite fuel. Use an UL approved fuel container to transfer gas to the engine.
- **Running / hot engine.** A running engine is hot enough to ignite fuel. Never add fuel or remove gas cap if engine is running or still hot. Stop the engine and allow to cool at least two minutes before adding fuel.
- **Heat / flames / sparks.** Keep sources of heat, flame, or sparks away while adding fuel.
- **Don't fill to the top** DO NOT overfill the gas tank. Allow at least 1” (2.5 cm) of empty space below the fill neck to allow for fuel expansion and operation on slopes.
- **Don't fill to the top.** Do not fill the gas tank to the top. Gasoline may spill when operating on a slope.
- **Replace cap.** Replace gas cap securely before starting engine.
- **Spills.** Clean up fuel spills immediately. Move grinder away from spilled fuel on the ground. Wipe fuel off engine and wait 5 minutes for excess fuel to evaporate before starting engine. Gas soaked rags should be disposed of properly.
- **On skin / clothes.** If gasoline is spilled on your skin or clothes, change clothes and wash skin immediately.
- **Inspect fuel system.** Check fuel system on a regular basis. Look for signs of leaks, deterioration, chafed or spongy fuel hose, loose or missing fuel hose clamps, damaged fuel tank, or a defective fuel shut-off valve. Do not start grinder until needed repairs have been completed.
- **Gasoline storage.** Store gasoline in a cool, dry place in an UL-approved, tightly sealed container away from children.

Safety – During Use

- **Safety equipment / controls.** Always operate the grinder with all safety covers, guards, and barriers in place and in good working order, and all controls properly adjusted for safe operation.
- **Controls.** Stay in the OPERATOR POSITION while actuating controls. Never attempt to ride or stand on stump grinder.
- **Know how to stop.** Know how to stop the grinder quickly if needed by releasing the operator presence bar. If this does not work, do the following in order until unit is stopped. 1. Push the stop button on the control panel. 2. Use on/off switch on engine (or ignition switch on electric start models). 3. Engage full choke by flooding the engine.
- **“Kickback”.** Machine can experience significant “kickback” when operating or first coming into contact with the stump.
- **Slipping/Falling.** Operating in wet or icy conditions could lead to losing your footing and slipping or falling.
- **Damaged.** Do not operate the grinder with damaged, missing, incorrectly adjusted, or broken parts.

Summary of Important Safety Information (cont'd)

- **Check for gas leak before starting.** After opening gasoline valve, smell for gas before starting engine. If you smell gas, DO NOT start engine. DO NOT light a match. DO NOT flip on an electrical switch. Exit area immediately and call fire department.
- **Carbon monoxide exhaust.** The running engine gives off carbon monoxide, a poisonous gas that can kill you. You CANNOT smell it, see it, or taste it. If you start to feel sick, dizzy, or weak while using the grinder, shut off the engine and get to fresh air RIGHT AWAY. See a doctor. You may have carbon monoxide poisoning.
- **Other exhaust dangers.** This product contains or emits chemicals known to the State of California to cause cancer, birth defects or other reproductive harm. Avoid inhalation of exhaust.
- **Smoking/sparks.** Never smoke near the running grinder, and never operate near sources of sparks or flames.
- **Hot muffler.** Never touch hot muffler or hot exhaust manifold. Exhaust and engine parts can be very hot and will burn you.
- **Machine's moving parts.** Keep hands, feet, and apparel away from drive belts, cutter wheel, and other moving parts. Never remove any drive belt or guard while the unit is operating. Contact with belt or rotating teeth will cause personal injury.
- **Refueling.** DO NOT refuel the engine until it has cooled at least two minutes.
- **Malfunction during operation.** Always shut the machine off if any unusual noise or vibration occurs.
- **Vibration.** Overexposure to machine vibration on a daily basis may lead to circulatory or nerve damage.
- **Adjusting / repairing.** Always turn off grinder and remove spark plug or spark plug wire before working on the grinder to prevent accidental starting. Disconnect battery (on electric models only).

Safety – After use

- **Cool engine before storing.** Let engine cool for at least five minutes before storing. A hot engine can be a fire hazard.
- **Shut off fuel supply.** Make sure gasoline shut-off valve is in the OFF position (Honda GX390 only).
- **Prevent accidental starting.** When grinder is not in use, remove key from starter (electric start engines) and secure in a safe location, or remove spark plug and disconnect positive battery terminal from battery in order to ensure that grinder cannot be started in a storage location or by untrained persons.
- **Storage location.** Store the grinder in a dry location away from sources of heat, open flames, sparks or pilot lights – such as water heaters, space heaters, furnaces, clothes dryers, or other gas appliances – EVEN IF the grinder's gas tank is empty. Residual gasoline could ignite.
- **Exercise regularly.** Exercise grinder every four weeks to dry out moisture that accumulates in the windings. If grinder cannot be exercised on a regular basis, prepare grinder for long-term storage.

Safety - Inspection/Maintenance

Inspect and maintain your grinder on a regular basis and repair as needed to keep it in safe working condition:

- **Turn off grinder.** Always turn off grinder and remove spark plug or spark plug wire before working on the engine or grinder to prevent accidental starting. Disconnect battery (on electric models only).
- **Replace guards / shields.** Make sure all guards and shields are replaced after servicing the grinder.
- **Burns.** Do not touch hot muffler. Muffler will be hot even if unit is stopped. Allow unit to cool before servicing.
- **Replacement parts.** If a part needs replacement, only use parts that meet the manufacturer's specifications. Replacement parts that do not meet specifications may result in a safety hazard or poor operation of the grinder and will void the warranty.

Special Safety Information on Static Electricity

Static electricity and filling gasoline:

Static electricity can initiate from ungrounded gasoline tanks or containers, from flowing gasoline, and from persons carrying a static electric charge

Static electricity on numerous occasions has explosively ignited gasoline vapors that were present during fueling processes, resulting in serious burns to nearby persons. To avoid static electricity while fueling, certain steps must be followed before and during the fueling process in order to minimize and safely dissipate static charge build-up.

Filling Portable Containers at Service Stations:

Use a portable container to fill grinder tank. Never fill the grinder's gas tank directly from the service station's fuel dispenser pump – the grinder's tank is not grounded and the high velocity flow of gasoline from a fuel pump can cause static electric build-up. Use an approved portable container to transfer gasoline to the grinder's tank.

- ***Use a portable container made of metal or conductive plastic.*** It will dissipate charge to ground more readily.
- ***Fill container on the ground.*** Never fill the portable gas container while it is sitting inside a vehicle, trailer, trunk, or pick-up truck bed. ALWAYS place container on the ground to be filled.
- ***Touch a grounded metal object before starting.*** Always dissipate static charge from your body before beginning the fueling process by touching a grounded metal object at a safe distance away from fuel sources.
- ***Keep nozzle in contact with container.*** Keep fuel dispenser nozzle in contact with the portable container at all times while filling at a service station. Do not use the nozzle lock-open device on the dispenser hose.

About static electricity and fueling

Many common objects can accumulate and retain a static electric charge. Objects made of non-conductive materials (e.g. plastics) easily accumulate and retain static electric charge, as can objects made of conductive material (e.g. metal, water) if they are not electrically grounded. The static electric charge on an object, such as a human body or plastic fuel tank/container, can reach as high as several thousand volts!

A static electric spark can be generated if the static electric charge stored on an object “jumps” to another, less charged object. Such a spark can ignite invisible gasoline vapors that are present during fueling situations.

Typical sources of static electric hazards during fueling

The following objects can accumulate a static electric charge and cause an ignition spark in typical fueling situations:

- Ungrounded tanks/containers. Any ungrounded fuel tank or container can accumulate a static electric charge as a result of contact with other objects or friction during transportation. This static electricity can discharge as a spark to the grounded gasoline dispenser nozzle, as the nozzle is first brought close to the tank/container at the beginning of the fueling process.
- Flowing gasoline. Most people are not aware that gasoline accumulates static electric charge while flowing through a hose or pipe. This charge then transfers to and accumulates in the gas tank or container that is being filled. The total amount of charge accumulation depends on the amount of gas pumped into the container, the speed with which it is pumped, and whether or not the tank/container is grounded. If sufficient static electric charge accumulates in the fuel tank or container during the fueling process, the tank/container may discharge a spark to the grounded gasoline dispenser nozzle.
- Persons. A person dispensing the gasoline can carry a static electric charge on their body, typically resulting from contact with their car seat or electronics. The static electricity can discharge as a spark between that person's hand and either the grounded dispenser nozzle or the fuel tank opening.

Exploded View – Rev AA

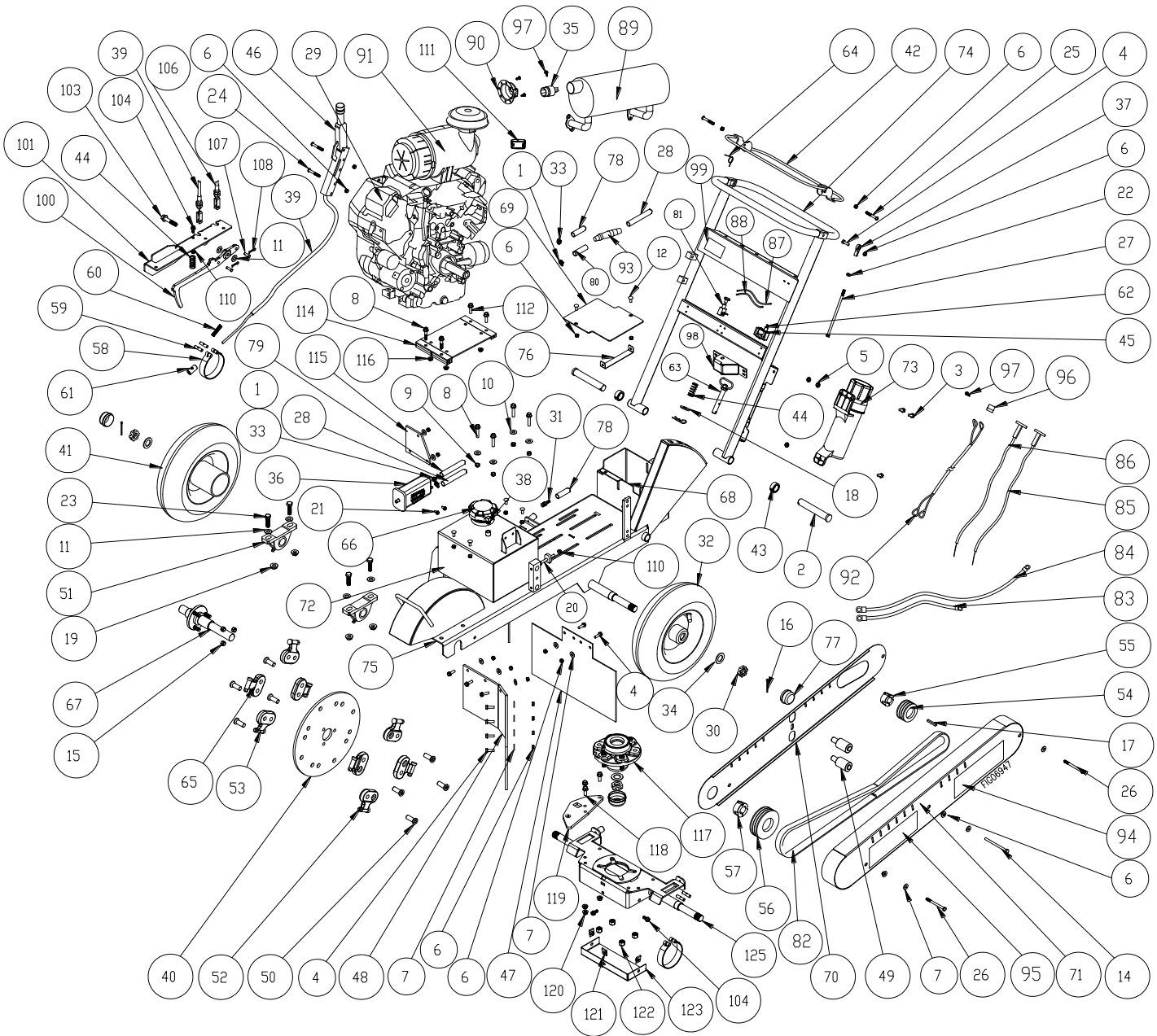

REPLACEMENT TEETH, POCKETS & BOLTS



Visit www.ceisupply.com or call 800-333-5234 for all your replacement teeth, pockets and bolts needs.

Personal Protection Equipment (not shown):

798999	Reusable corded earplugs	1
799000	Face shield	1
799001	Safety eyewear	1
799003	Safety gloves	1

Parts List – Rev AA

Item	Part #	Description	Qty	Model	Item	Part #	Description	Qty	Model
1	30746	3/8" Hose Clamp	2	620	55	783563	Bushing, 1"	1	337
2	37878	1" x 6" Clevis Pin	2	All		784053	Bushing, 1-1/8"		620
3	82015	5/16"-18 x 3/4" HHSF Bolt	3	All	56	783564	4.75" Sheave, 3 Groove	1	337
4	82016	5/16"-18 x 1" HHSF Bolt	11	All		784054	4.75" Sheave, 4 Groove		620
5	82019	5/16"-18 Ser. Flange Nut	7	All	57	783565	Bushing, 1-3/16"	1	All
6	82020	5/16"-18 Nylon Locknut	17	337	58	783567	4" Brake Band	1	337
			19	337S				2	337S
			23	357	59	783568	Floating Pin	2	337
			29	620				4	337S
7	82021	5/16" USS Flat Washer	12	337	60	783569	1.5" Spring	1	337
			13	337S				620	
			18	620	61	783570	Cable Clamp	1	All
8	82025	3/8"-16 x 1 3/4" HHSF Bolt	4	All	62	783545	Microswitch	1	All
9	82027	3/8"-16 Nylon Locknut	4	All	63	783774	4" Hitch Pin	1	All
10	82028	3/8" USS Flat Washer	4	All	64	783924	Spring	1	All
11	82038	1/2" SAE Flat Washer	4	All	65	783559	700 Series Angled Pocket	4	All
12	82088	5/16"-18 x 3/4" Carr. Bolt	6	620	66	784769	Sealed Fuel Cap	1	620
14	82097	5/16"-18 x 4 1/2" HHCS Bolt	1	All	67	785079	Cutter Shaft	1	All
15	82334	7/16"-20 Nylon Locknut	3	All	68	785128	Battery Box	1	620
16	82140	Cotter Pin	2	All	69	785130	Battery Box Top	1	620
17	82143	1/4" X 1-3/4" Key	1	All	70	785134	Inner Belt Guard	1	All
18	82286	5/8" USS Flat Washer	1	All	71	785136	Outer Belt Guard	1	All
19	82291	1/2"-13 Flange Locknut	4	All	72	785581	Fuel Tank	1	620
20	82096	5/16"-18 x 3.5" Bolt	1	All	73	788040	Manual Tube	1	All
21	82308	M6-1 x 12MM HHCS Bolt	2	620	74	796186	Handle	1	620
22	82312	5/16"-24 Hex nut	1	All		801623			337S
23	82316	1/2"-13 x 1.75" Bolt	4	All	75	802740	Frame	1	337
24	82322	5/16"-18 x 2.25" Bolt	2	All		802848			620
25	82017	5/16"-18 x 1 1/2" Bolt	2	All		801609			337S
26	82353	5/16"-18 x 3.75" HHCS Bolt	2	All	76	793512	Battery Hold-Down Strap	1	620
27	82392	Linkage	1	All	77	124A	Dust Cap	2	All
28	801491	Hose, 3/8" Fuel Line	60"	620	78	801490	Hose, 1/4" Fuel Hose	50"	620
29	787618	GX390 Honda Cyclone	1	337-13HC	79	801490	Hose, 1/4" Fuel Line	11"	All
	601091	GX390 Honda		337-13H	81	786073	On/Off Switch w/ Black Knob	1	All
	787618	GX390 Honda Cyclone		337S-13HC		786074			
	803515	GX630 Honda		620-20HE					
30	777124	1" Slotted Nut	2	All	82	783561	Belt, 3 Groove	1	337
31	777340	1/4" MPT x 1/4" Hose Barb	1	620		784056	Belt, 4 Groove	620	
32	777799	Wheel	1	337	83	777108	24" Battery Cable (Black)	1	620
	783484	Wheel & Brake Drum	1	337S	84	793517	43" Battery Cable (Red)	1	620
33	777834	1/4" Hose Clamp	4	620	85	784208	Choke Cable	1	620
34	778844	Axle Washer	2	All	86	784207	Throttle Cable	1	620
35	802314	Spark Arrestor	1	620	87	783285	8" Lead Wire, Green	1	All
36	801497	Carbon Canister	1	620	89	783395	Muffler	1	620
37	782399	Ball Joint Rod	1	All		784059	Muffler Canister		
38	783212	1/4" x 1/4" Hose Barb Elbow	1	620	90	785508	Exhaust Deflector w/ Screws	1	337
39	783295	Brake Cable	1	337	91	785411	Air Cleaner for GX630	1	620
	620			92	786072	Wire Harness	1	337	
	337S				794353			620	
40	783480	Cutter Wheel, 14"	1	All	94,	802880	337 Branding Decal Set	1	337
41	783484	Wheel & Brake Drum	1	All	95,	802879	337S Branding Decal Set	1	337S
42	783493	Operator Presence Handle	1	All	99	802883	620 Branding Decal Set	1	620
43	803313	Lock Collar	2	All	96	780091	12V, 80 Amp Relay	1	620
44	783539	2" Spring	1	337	97	82166	1/4" x 1/2" Self-Tap Screw	2	620
			2	337S	98	796222	Lock Bracket	1	All
45	783769	Microswitch Bracket	1	All	100	801704	Latch Lever	1	337S
46	783547	Brake Lever Assembly	1	All	101	801684	Swivel Latch Mount	1	337S
47	801705	End Flap	1	All	103	82628	1/2-13 X 2.5 HHFB	1	337S
48	783551	Chute Flap	1	All	104	82621	5/16-18 X .75 HHFB	4	337S
49	783552	Idler Bearing	2	All	106	801699	Cable, Latch to Brake	1	337S
50	783555	Lo-Pro Pocket Bolt	8	All	107	802022	Cable Pin	2	337S
51	783556	Pillow Block Bearing	2	All	108	802023	Cable Cotter Key	2	337S
52	792160	700 Series Tooth	8	All					
53	784166	700 Series Straight Pocket	4	All					
54	783562	3" Sheave, 3 Groove	1	337					
	784052	3.35" Sheave, 4 Groove		337S	620				
-	-	-	-	-					

Parts List – Rev AA

Item	Part #	Description	Qty	Model
110	82630	5/16-18 Lock Hex Flange Nut	2	All
111	801652	Hour Meter	1	337 337S
112	82024	3/8-16 X 1 1/4 HHSF	2	337S
113	82625	3/8-16 X 1.75 HHFB	6	337S
114	801634	Engine Riser	1	337S
115	801625	Corner Flap	1	337S
116	82290	3/8-16 Lock Nut	4	337S
117	801760	Pivot Hub	1	337S
118	82624	3/8-16 X 1" HHCS	3	337S
119	801620	Swivel Wear Plate	1	337S
120	82631	3/8-16 Lock Hex Flange Nut	3	337S
121	82720	5/16-18 U Nut	3	337S
122	82685	1/2"-20 Nylon Lock Nut	4	337S
123	801627	Dust Cap Guard	1	337S
125	801606	Swivel Sub-Base	1	337S

Wiring Diagram 337, 337S

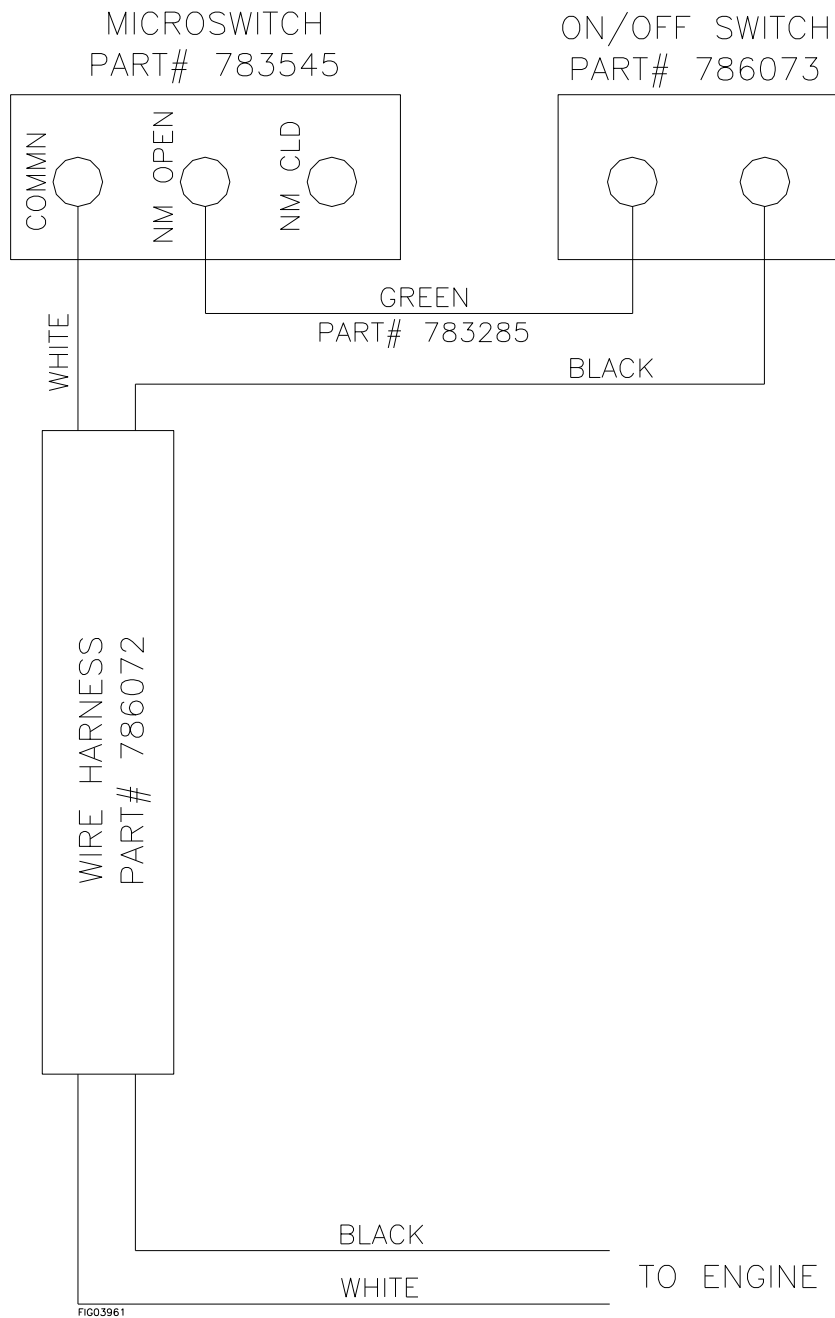

Wiring Diagram 620-20HE

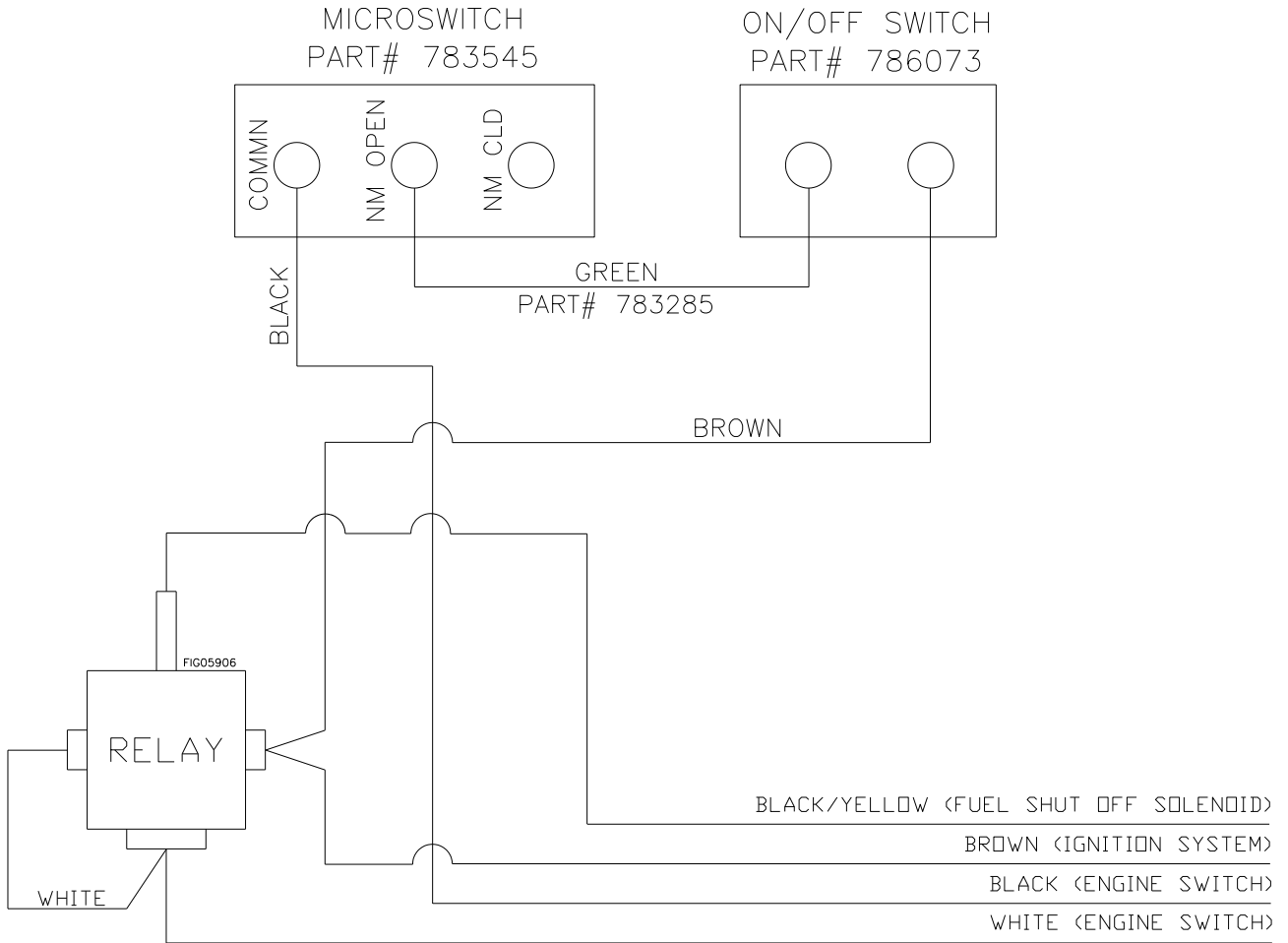

Wiring Diagram 620-25KE

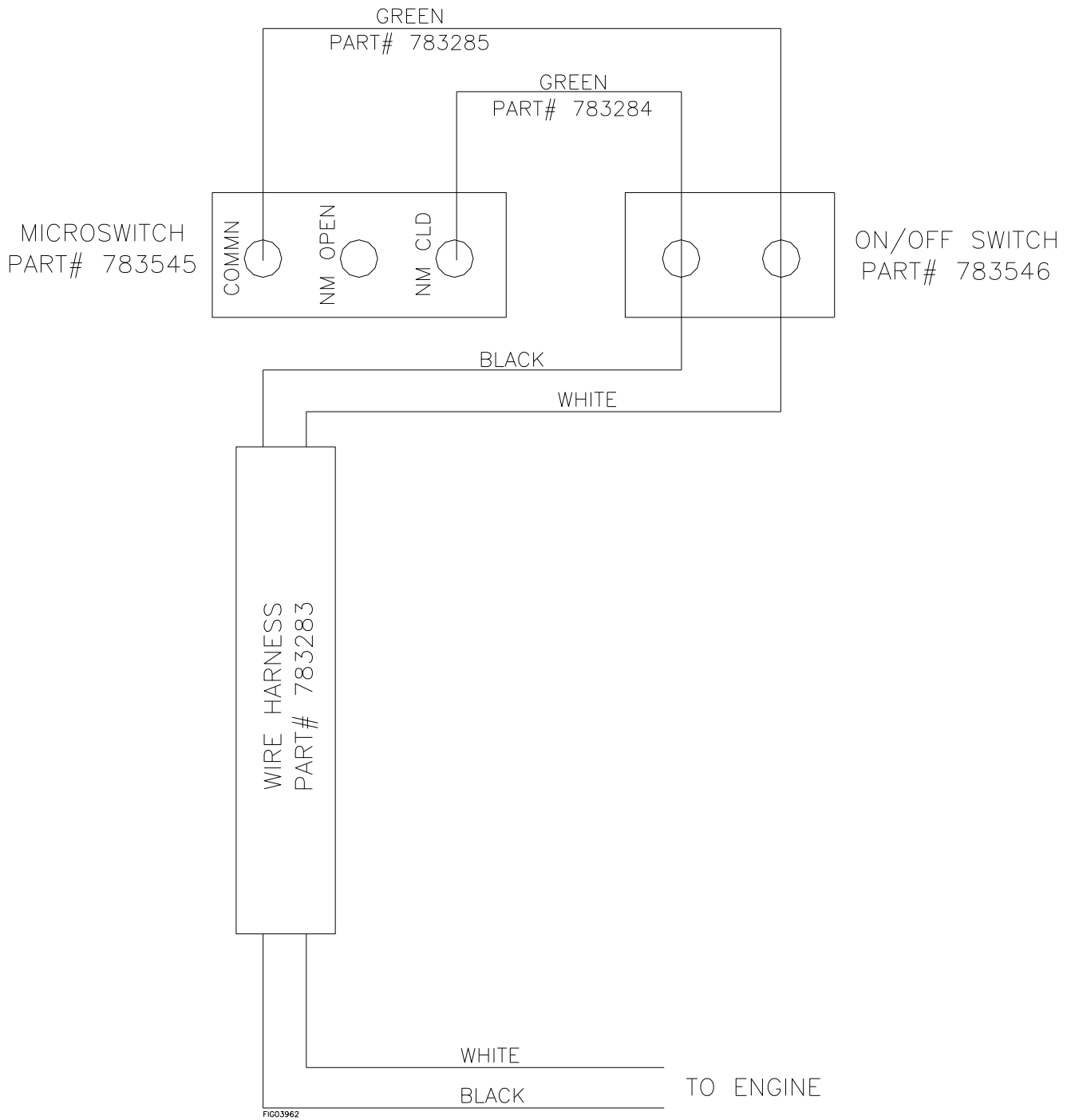

Assembly Instructions

Dismantle crate, remove packing materials from the handle bar and adjustable brake lever, remove box from the stump grinder, and remove the contents of the box.

Closely inspect all stump grinder components.

If you have missing or damaged components, please contact Product Support at 1-800-822-0295 or 1-763-428-2237.

Find a work space that is large enough to maneuver stump grinder once completely assembled. Assemble stump grinder on solid and level ground.

Tools needed: 5/32" (4mm) allen wrench, adjustable wrench, 1/2" (13mm) end wrench, 10mm end wrench, phillips head screw driver.

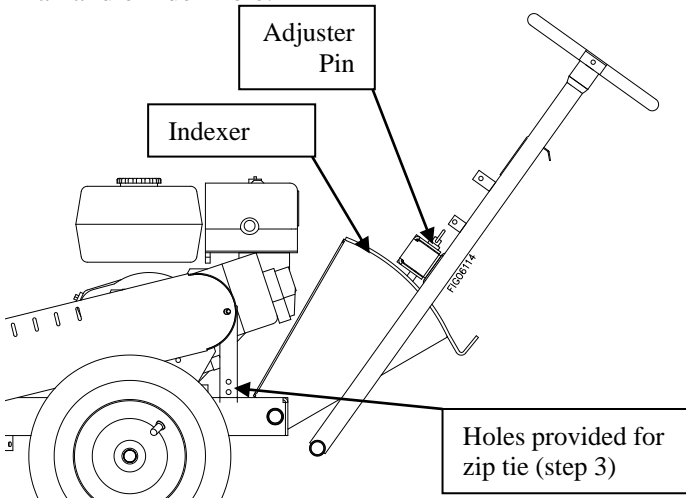
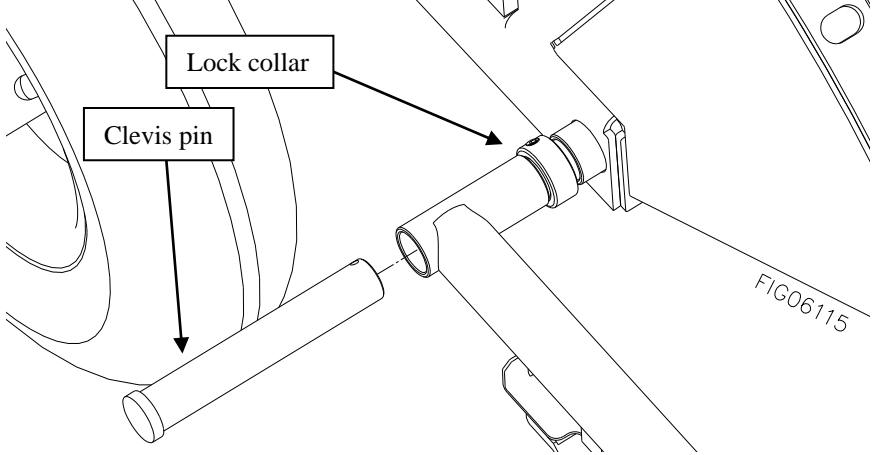
1. Maneuver handle over engine	<p>Maneuver handle over engine, being careful not to damage engine, pull cables loose, or damage wiring. Then, set the handle bar on the indexer as shown with adjuster pin in a handle index hole.</p>  <p>FIG06114</p>
2. Install handle	<p>Align pivot holes with frame holes and insert clevis pin with lock collar in place as shown.</p>  <p>FIG06115</p> <p>Apply thread lock to collar set screw threads. Tighten set screw in lock collar.</p> <p>Repeat for the other side of the handle.</p>
3. Secure wiring	<p>Zip tie wiring in place along handle and to frame (use holes shown in step 1 for frame location).</p>

Assembly Instructions

4. Mount adjustable brake lever

Align bolt holes in the adjustable brake lever with the holes in the mounting posts on the stump grinder handle bar and install bolts with nuts.

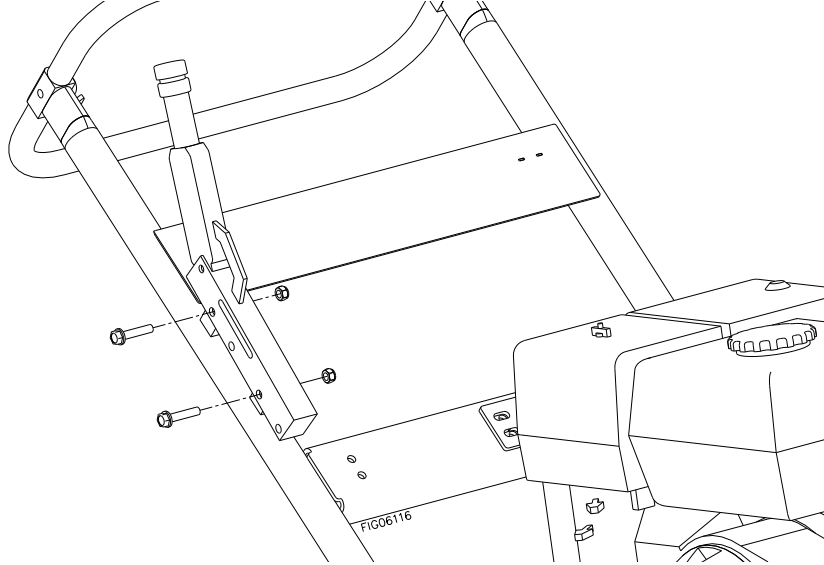

5. Install air cleaner assembly (620 only)

Align air cleaner mount with bolt holes and install bolts as shown. Then, remove the tape from the intake on engine.

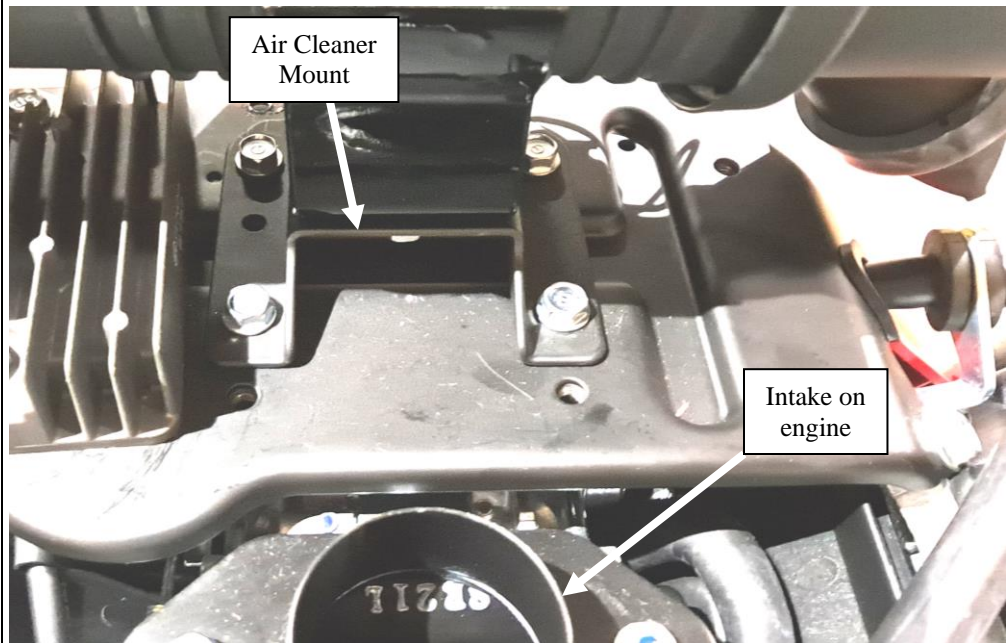

Assembly Instructions

Install air cleaner hose as shown and tighten hose clamp.

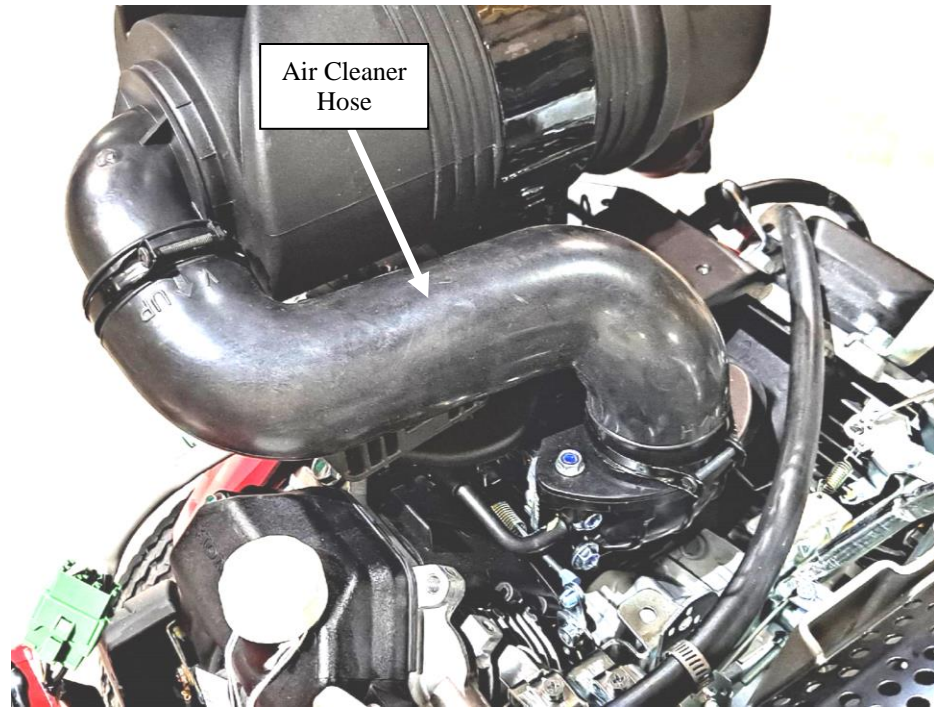

Identify EVAP hose. It will be the only hose with a loose end. The end which is not loose will be attached to the carbon canister located on top of the gas tank. Install loose end of EVAP hose to air cleaner as shown. Loosen, reposition hose clamp, and tighten to secure hose to air cleaner.

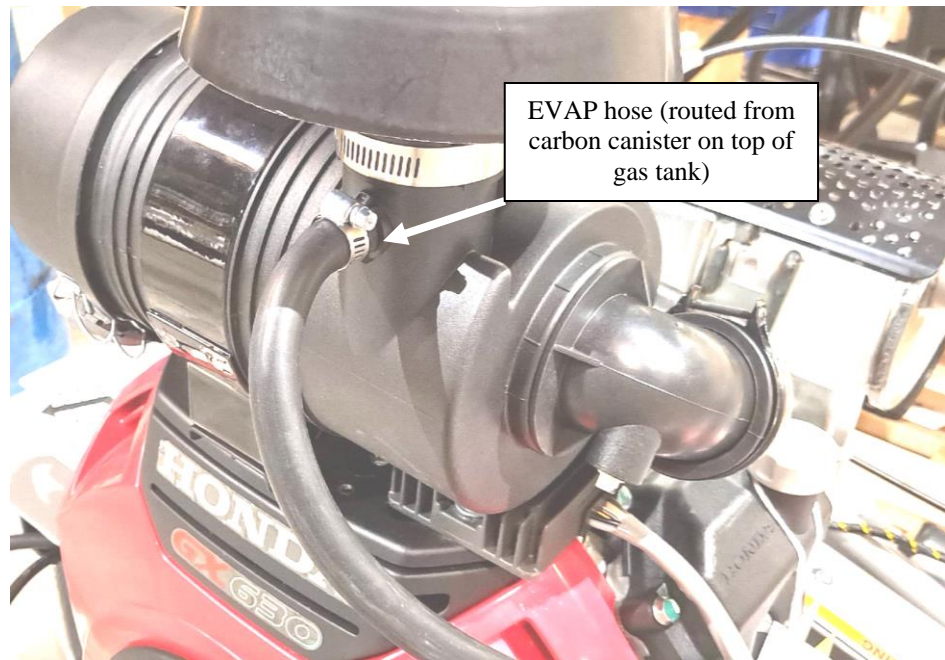

Limited Warranty Policy

Dear Valued Customer:

The Dosko product you just purchased is built with the finest material and craftsmanship. Use this product properly and enjoy the benefits from its high performance. By purchasing a Dosko product, you show a desire for quality and durability. Like all mechanical equipment this unit requires a due amount of care. Treat this unit like the high quality piece of machinery it is. Neglect and improper handling may impair its performance.

Thoroughly read the instructions and understand the operation before using your product. Always contact Dosko Product Support at 1-866-298-3659 prior to having any service or warranty work performed, as some services performed by parties other than Dosko approved service centers may void this warranty. This limited warranty is in lieu of any other warranty expressed or implied, written or oral and Dosko assumes no other responsibility or liability outside that expressed within this limited warranty.

Limited Warranty for Stump Grinder Models:

200-6HC	200-6H	691SP-20HE
337S-13HC	620-20HE	691SP-25KE
337-13HC	620-25KE	337-13H

	Consumer Warranty Period	Commercial Warranty Period
Weldments	2 years from date of purchase by user	2 year from date of purchase by user
Hydraulic Motor, Valves, Pumps	2 years from date of purchase by user	1 year from date of purchase by user
Wear Parts	In addition to the normal warranty, Dosko shall warrant some normal wear items from defects in material or workmanship for a period of 30 days from the date of purchase by user. Normal wear items covered under this warranty are limited to: tires, belts, grease zerks, hoses, bearings, hoses, teeth, pockets, bolts, clutches, switches, wires, cables. Routine maintenance items such as lubricants, clutch adjustments, tune ups are not covered under warranty.	
Engines	The engine warranty is covered under the terms and conditions as outlined by the engine manufactures warranty contained herein and is the sole responsibility of the engine manufacturer. Normal engine maintenance such as spark plugs, oil changes, air filters, adjustments, fuel system cleaning and obstruction due to build up is not covered by this Dosko limited warranty.	

“**Consumer use**” means personal residential household use by a consumer. “**Commercial use**” means all other uses, including, but not limited to, use for commercial, income producing or rental purposes or when purchased by a business.

This limited warranty applies to the original purchaser of the equipment (verification of purchase, in the form of a receipt, is the responsibility of the buyer), is non-transferable, and covers parts and labor. Parts will be replaced or repaired at no charge, except when the equipment has failed due to lack of proper maintenance. If a part is no longer available, the part may be replaced with a similar part of equal function. Any misuse, abuse, alteration or improper installation or operations will void warranty. Determining whether a part is to be replaced or repaired is the sole decision of Dosko. Dosko will not provide for replacement of complete products due to defective parts. Any costs incurred due to replacement or repair of items outside of a Dosko approved facility is the responsibility of the buyer and not covered under warranty. Transportation costs to and from service center and/or service calls are the responsibility of the customer.

This limited warranty specifically excludes the following; failure of parts due to damage caused by accident, fire, flood, windstorm, acts of God, applications not approved by Dosko in writing, corrosion caused by chemicals, use of replacement parts which do not conform to manufacturer’s specifications, damage related to rodent and/or insect infestation and damage caused by vandalism. Additional exclusions: loss of running time, inconvenience, loss of income, or loss of use, including any implied warranty of merchantability of fitness for a specific use. Also, outdoor power equipment needs periodic parts and service to perform well, and this limited warranty does not cover instances when normal use has exhausted the life of a component or the engine.

This limited warranty does not cover any personal injury or damage to surrounding property caused by failure of any part, misuse or inability to use the product. Alteration of the product, including safety features, shall void this limited warranty and CE certification.

Repair or replacement of parts does not extend the warranty period. This limited warranty gives you specific legal rights. You may also have other rights that vary by state.

Please have model number, item number and serial number on hand prior to making a warranty claim or inquiry.

This page is intentionally left blank



WARNING: This product can expose you to chemicals including soots, tars, and mineral oils, which are known to the State of California to cause cancer, and carbon monoxide, which is known to the State of California to cause birth defects or other reproductive harm. For more information go to www.P65Warnings.ca.gov.

DOSKO

Great Northern Equipment Distributing Inc.
20195 S. Diamond Lake Rd, Ste 100
Rogers, MN 55374
Made in USA

Authorized Representative
QNET BV
Hommerterweg 286
6436 AM Amstenrade
The Netherlands