

210x290mm(正)

Pacific Accents™
Sparkler Lights™
 Patent(s) Pending



READ AND FOLLOW ALL INSTRUCTIONS BEFORE OPERATING YOUR SPARKLER LIGHTS. SAVE THIS MANUAL FOR FUTURE REFERENCE.

Part	Quantity
Yard-Spikes	2
Reusable Cable Ties	4
Remote Control	1
S-Hook Hangers	2
Sparkler LED Lights With Power Cord	2

Remote Specification

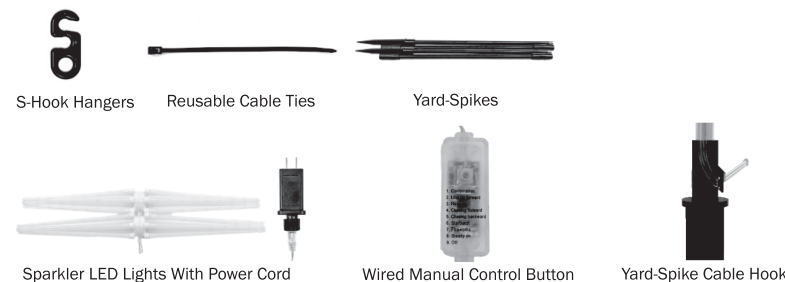
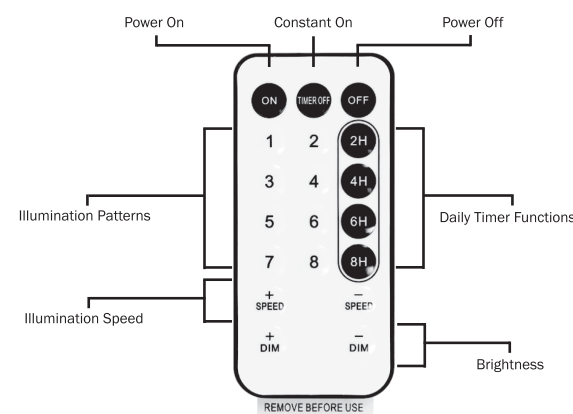

INSTALLATION

YARD:

Each set of Sparker Lights includes two yard-spikes. Assemble the spikes by sliding the male end of the pointed segment into the female connector of the non-pointed segment. Insert the assembled stakes into the ground in a location of your choosing – be certain the two stakes are no more than six feet away from each other.

Once you have the stakes in the ground, attach the male end of each Sparkler Light into the female end of the assembled stake. A small inverted hook is located at the top of the base of each spike - slide the lead cable through it and pull taut to align along the length of each spike. Use two of the cable ties per spike to fasten the lead cables in place. PLEASE NOTE: The cable ties can be opened and reused by depressing the small lever located on the lock and sliding the cable out.

Once the Sparker Lights have been attached to each stake, carefully unfold and open each individual light element fully. DO NOT OVEREXTEND the light elements – doing so may break the pivot points. When completed, your Sparker Light should look like a multi-pointed three-dimensional star.

HANGING:

Sparkler lights can also be hung from fixed and secure locations such as eaves, tree limbs and pergolas. We have included two S shaped hooks for this purpose. To use, simply suspend the S-Hook by sliding the large round hole over a branch, protruding screw or nail. Once the S-Hook is in place, twist the cable leading to each sparkler through and around the bottom loop of the S until taught; you may have to twist it more than once depending on where it is located.

ACTIVATION/FUNCTION:

After setting up your Sparkler Lights, plug them into a source of 120 V electricity. Your lights can be activated manually or with the included remote control. To activate manually, depress the push button located on the wired control box once. When activated, the wired control box will illuminate in green. Pressing the button sequentially will change the Sparklers illumination pattern ONLY. The patterns available through manual control are as follows:

- Combination** – All Patterns Flash Sequentially
- Line Up Forward** – lights illuminate and fill toward the light ends
- Head Up** – lights illuminate in pairs and fill toward the ends
- Chasing Forward** – lights move sequentially toward the end of each segment
- Chasing Backward** - lights move sequentially from the end of toward the center of each the Sparkler
- Starburst** – light segment illuminates fully and fades out toward each segment end
- Fireworks** – lights illuminate and move toward each segment end while fading
- Steady on** – light segments are constantly on at full brightness.

REMOTE CONTROL:

To access your Sparker Lights full functionality the included remote control must be used. Before first use, remove the battery insulator strip located in your remotes battery compartment. To use the remote, point it toward the manual control box and select the button(s) associated with the function(s) you would like to use. Functions for your remote are as follows:

- 1 – 8** – Select a number to control the illumination pattern; each number is equivalent to the functions listed above.
- ON** – Turns your lights on.
- OFF** – Turns your lights off.
- TIMER OFF** – Turns off and resets timer functions.
- + SPEED** – Increases the speed lights move & illuminate at.
- SPEED** - Decreases the speed lights move & illuminate at.
- + DIM** - Increases the brightness of your Sparkler Lights.
- DIM** - Decreases the brightness of your Sparkler Lights.

Timer Functions – Sparkler Lights have daily timer that illuminate automatically at a time of your choosing and turn off after a predetermined time. The time the lights will remain on are two hours, **(2H)**, four hours, **(4H)**, six hours, **(6H)**, & eight hours, **(8H)**. To activate, choose the amount of time you would like the lights to illuminate, and chose the corresponding hour button at the time you would like the lights to turn on. The lights will turn off automatically after the duration chosen and restart the next day at the same starting time.

DO NOT LOSE YOUR REMOTE – full functionality is only available via your remote control.

210x290mm(反)

CHANGING YOUR REMOTE BATTERY:

If your remote control doesn't function properly its battery likely needs to be replaced. The battery is in a sliding battery tray located on the rear bottom of your remote control. To open, press in the RELEASE button located on the right-hand side of the battery tray, slide out the tray, and remove the old battery. Insert a new CR2025 button cell battery according to the polarity graphic located on the rear of your remote and return tray to the closed position.

CARE

- DO NOT DISPOSE OF INSTRUCTIONS – KEEP FOR FUTURE USE.
- DO NOT OVEREXTEND the light elements – doing so may break the pivot points.
- Fully Close Sparkler Lights illuminated heads for safe storage.
- Disassemble stakes and cable ties for safe storage.
- CAREFULLY wind-up Sparker Lights cords for safe storage.
- Store all Sparkler Lights parts together.
- Remove the remote control's battery if not in use for extended time periods.
- Dispose of old batteries according to the recycling regulations of your country, state, county or community

CAUTION

- NEVER disassemble or other wise alter or change the product.
- WARNING: Risk of electronic shock if used Improperly.
- Insert into outlets located greater than 1' above ground surface.
- Do not place product or cables in standing water.
- Do not secure the wiring of the product with staples or nails, or place on sharp hooks or nails. Install only using the mounting means provided.
- Do not hang objects from light source, cable, or wire.
- Do not close doors or windows on the product's cable or extension cords as this may damage the wire insulation.

IMPORTANT SAFETY INSTRUCTIONS

When using electrical products, basic precautions should always be practiced including the following:

1. READ AND FOLLOW ALL SAFETY INSTRUCTIONS.

- Read and follow all instructions that are on the product or provided with the product.
- For a cord-connected or direct plug-in power unit, do not use an extension cord.
- Reference the National Electrical Code, NFPA 70, specifically for the installation of wiring and clearances from power and lighting conductors.
- Installation work and electrical wiring must be done by qualified person(s) in accordance with all applicable codes and standards, including fire-rated construction.
- Do not install or use within 10 feet of a pool.
- Do not use in a bathroom.
- WARNING:** Risk of Electric Shock. When used outdoors, install only to a covered Class A GFCI protected receptacle that is weatherproof with the power unit connected to the receptacle. If one is not provided, contact a qualified electrician for proper installation. Ensure that the power unit and cord do not interfere with completely closing the receptacle cover.
- WARNING:** Risk of Fire. Installation involves special wiring methods to run wiring through a building structure. Consult a qualified electrician.

SAVE THESE INSTRUCTIONS – This manual contains important safety and operating instructions for power units.

This device complies with Part 15 of the FCC Rules. Operation is subject to the following two conditions: (1) this device may not cause harmful interference, and (2) this device must accept any interference received, including interference that may cause undesired operation.

"Please note that changes or modifications of this product is not expressly approved by the party responsible for compliance could void the user's authority to operate the equipment."

NOTE: This equipment has been tested and found to comply with the limits for a Class B digital device, pursuant to Part 15 of the FCC Rules. These limits are designed to provide reasonable protection against harmful interference in a residential installation. This equipment generates, uses and can radiate radio frequency energy and, if not installed and used in accordance with the instructions, may cause harmful interference to radio communications. However, there is no guarantee that interference will not occur in a particular installation.

If this equipment does cause harmful interference to radio or television reception, which can be determined by turning the equipment off and on, the user is encouraged to try to correct the interference by one or more of the following measures:

- Reorient or relocate the receiving antenna.
- Increase the separation between the equipment and receiver.
- Connect the equipment into an outlet on a circuit different from that to which the receiver is connected.
- Consult the dealer or an experienced radio/TV technician for help.

Model: 802060

30 DAYS LIMITED WARRANTY:

FLIPO GROUP warrants to the original purchaser, when used in North America only, that this product shall be free of defects in material and workmanship. This warranty applies within 30 days of the original purchase with normal home use. This warranty does not apply for commercial use of this product. Use outside of North America is not covered by this warranty.

During the warranty period, we will at our option, repair or replace this product without charge, which shall be the consumer's sole remedy. ALL RETURNS must be accompanied by a Return Authorization Number, which is issued by the Customer Service Department of Flipo Group. Please contact Customer Service BEFORE returning any item. Once you have obtained a Return Authorization Number, the product must be returned with a clear copy of the proof of purchase, showing place and date of purchase, postage and insurance prepaid to:

Flipo Group
 613 First Street
 La Salle, IL 61301

This warranty does not cover installation, adjustments in the home, nor damage due to accidents, misuse, abuse, fire or other acts of God, incorrect line voltage, damage to other equipment caused by improper installation, unauthorized or improper modification. This warranty gives you specific legal rights and you may also have other rights that vary from state to state.



Manufactured by Flipo Group Limited La Salle, IL • flipo.com • Questions or Comments? Call: (815)223-9942 • Email: info@flipo.com • Fax: (815) 223-9266

MADE IN CHINA