

WOOD STOVE OWNER'S MANUAL

MODEL: FF-WP-200



woodpro
BY FORGE & FLAME

Find helpful videos
and information on our
Getting Started page

Scan Here



Congratulations

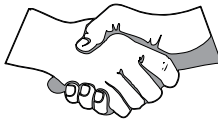

and Welcome to the WoodPro Family!

NOTE: Clearances may only be reduced by means approved by the regulatory authority having jurisdiction

A. Sample of Serial Number / Safety Label

LOCATION: Back of appliance

CAUTION: HOT WHILE IN OPERATION DO NOT TOUCH, KEEP CHILDREN AND CLOTHING AWAY. CONTACT MAY CAUSE SKIN BURNS. KEEP FURNISHINGS AND OTHER COMBUSTIBLE MATERIAL FAR AWAY FROM THE APPLIANCE. SEE NAMEPLATE AND INSTRUCTIONS.

ATTENTION: CHAUD LORS DE L'OPÉRATION. NE PAS TOUCHER. GARDEZ LES ENFANTS ET LES VÊTEMENTS LOIN DE L'ESPACE DÉSIGNÉ DE L'INSTALLATION. LE CONTACT PEUT CAUSER DES BRÛLURES À LA PEAU. GARDEZ LES MEUBLES ET LES MATÉRIEAUX COMBUSTIBLES LOIN DE L'ESPACE DÉSIGNÉ DE L'APPAREIL. VOIR L'ÉTIQUETTE ET LES INSTRUCTIONS.

woodpro
BY FORNE + FLAME

FF-WP-200

Serial No. / N° de série

HF

BARCODE LABEL

TESTED TO / TESTÉ À :
ASTM E2515, ASTM E2780, UL1482, UL6 S627-00.

VENT SPECIFICATIONS / SPÉCIFICATIONS DE LA VENTILATION:

SINGLE WALL: Six inch (6 inches) (152mm) diameter, minimum 24 MSG black or blued steel connector pipe, with a listed factory-built UL103HT[†] Class "A" chimney, suitable for use with solid fuels, or a masonry chimney, and the referenced clearances. / **MUR SIMPLE:** De six (6 inches) (152mm) de diamètre, minimum 24 MSG acier noir ou bleu, avec une cheminée bâtie en usine UL103HT[†] de Classe "A", adéquate pour usage avec les combustibles solides, ou une cheminée de briques, avec espaces libres référencés.

DOUBLE WALL: Six inch (6 inches) (152mm) diameter, listed double wall air insulated connector pipe with listed factory-built UL103HT[†] Class "A" chimney, or a masonry chimney and the referenced clearances. / **MUR DOUBLE:** De six (6 inches) (152mm) de diamètre, le connecteur de conduit d'air isolé pour mur double avec une cheminée bâtie en usine UL103HT[†] de Classe "A", ou une cheminée de briques, avec espaces libres référencés.

MOBILE HOME: Use double wall pipe by Dura-Vent DVL, Selkirk Metalbestos DS or Security DL double wall connector pipe. Must be equipped with a spark arrester. Apply double wall clearances below when installing unit. / **MAISON MOBILE:** Utiliser un conduit de mur double par Dura-Vent DVL, Selkirk Metalbestos DS ou Security DL. Doit être équipé d'un arrêt d'éclaboussure. Réviser les espaces libres pour mur double comme mentionné ci-haut.

MINIMUM CLEARANCES TO COMBUSTIBLE MATERIALS: In Inches & (Millimeters) / **ESPACES LIBRES MINIMUM DES MATÉRIEAUX COMBUSTIBLES:** En Pouces & (millimètres)

NOTE: AU "A", "C" and "P" Dimensions are to inside diameter of the flue. / **REMARQUE:** Toutes les dimensions "A", "C", et "P" sont à partir du diamètre intérieur de l'entrée du conduit.

INSTALLATION	FULL VERTICAL OR HORIZONTAL WITH MINIMUM 2 FT VERTICAL	STOVE TOP / INSTALLATION ENTièrement VERTICALE OU HORIZONTALE AVEC 609mm VERTICAL MINIMUM DU HAUT DU POÊLE					
SINGLE WALL PIPE / CONDUIT DU MUR SIMPLE	A	B	D	E	F	G	H
FF-WP-200	14 (354)	8 (203)	16 (406)	8 (203)	20 (508)	48 (1220)	12 (305)
DOUBLE WALL PIPE / CONDUIT DU MUR DOUBLE							
FF-WP-200	13.5	25 (635)	13 (330)	6.5 (165)	18.5 (470)	48 (1220)	9 (229)
INSTALLATION 90° ELBOW OFF TOP OF STOVE / INSTALLATION 90° DU COURBURE AU DESSUS DE HAUT DU POÊLE À TRAVERS LE MUR ARRIÈRE							
FF-WP-200	8 (203)	8.5 (216)	25 (635)	13 (330)	8 (203)	20 (508)	48 (1220)
DOUBLE WALL PIPE / CONDUIT DU MUR DOUBLE							
FF-WP-200	11 (279)	6.5 (165)	26.5 (673)	6.5 (165)	18.5 (470)	48 (1220)	6 (152)
INSTALLATION 90° ELBOW OFF TOP OF STOVE / INSTALLATION 90° DU COURBURE AU DESSUS DE HAUT DU POÊLE À TRAVERS LE MUR ARRIÈRE							
FF-WP-200	14.75 (375)	8.25 (210)	26.5 (673)	14.5 (368)	N/A	N/A	48 (1220)

FLOOR PROTECTION: Floor protector must be a 3/8" (9.5mm) thick, non-combustible material or equivalent, extending beneath heater and to front/rear as indicated on the diagram below. Exception: Non-combustible floor protectors must extend beneath the flue pipe when installed with horizontal venting and extend 2 inches (51mm) beyond each side.

PROTECTION DU PLANCHER: Le protecteur de plancher doit être d'un minimum de 3/8" (9.5mm) d'épaisseur, de matériel incombustible ou équivalent, et se prolonger au-dessus de l'appareil de chauffage à l'avant, aux côtés et à l'arrière comme indiqué sur le diagramme suivant. Exception: Les protections incombustibles du plancher s'étendent en dessous du conduit de cheminée avec une ventilation à horizontale et s'étendent de 51mm (2") de chaque côté.

USA
16" from glass
3/8" minimum
Millimeter 31.50* Min

CANADA
457mm (18")
203mm (8")
203mm (8")
124mm (49") minimum
1041mm (41") minimum

SEE PIPE MANUFACTURERS CLEARANCES - NOT TESTED / VOIR LE FABRICANT POUR LES ESPACES LIBRES DES CONDUIT - PAS TESTÉ

90° OFF TOP UP & OUT CEILING CLEARANCE
ESPACE LIBRE DU DESSUS DE L'APPAREIL AU PLAFOND AVEC 90° DE COURBURE

ALCOVE TOP VIEW / VUE DU HAUT DE L'ALCOVE

CORNER INSTALLATION / INSTALLATION DU COIN

BACK WALL / SIDE WALL / MUR ARRIÈRE / MUR DE CÔTÉ

Manufactured by: **HEARTH HOME**
352 Mountain House Road, Halifax, PA 17032, www.forgentime.com

Made in U.S.A. of US and imported parts. / Fabriqué aux États-Unis d'Amérique par des pièces d'origine américaine et pièces importées.

U.S. ENVIRONMENTAL PROTECTION AGENCY
Certified to comply with 2020 particulate emission standards at 1.9 g/hr EPA Method 28 and 50. This wood heater needs periodic inspection and repair for proper operation. Consult the owner's manual for further information. It is against federal regulations to operate this wood heater in a manner inconsistent with the operating instructions in the owner's manual.

DO NOT REMOVE THIS LABEL / NE PAS ENLEVER L'ÉTIQUETTE

Serial No.

Safety & Emissions Test Report Name

Test Lab & Report No.

Mfg. Date



Safety Alert Key:

- **DANGER!** Indicates a hazardous situation which, if not avoided will result in death or serious injury.
- **WARNING!** Indicates a hazardous situation which, if not avoided could result in death or serious injury.
- **CAUTION!** Indicates a hazardous situation which, if not avoided, could result in minor or moderate injury.
- **NOTICE:** Indicates practices which may cause damage to the appliance or to property.

TABLE OF CONTENTS

A. Sample of Serial Number / Safety Label	2	3 Maintenance and Service	
B. Warranty Policy	4	A. Quick Reference Maintenance Guide	14
C. Quick Start Guide.	5	B. General Maintenance.	15
1 Listing and Code Approvals		C. Correct Baffle & Blanket Placement.	17
A. Appliance Safety Certification	6	4 Troubleshooting Guide	18
B. Appliance Emissions Certification	6	5 Service Part Replacement	
C. BTU & Efficiency Specifications.	6	A. Glass	19
D. Glass Specifications.	7	B. Firebrick	19
E. Mobile Home Approved	7	C. Door Handle Assembly	20
F. Sleeping Room.	7	D. Baffle Removal.	20
G. California - Prop65.	7	E. Tube Channel Assembly	21
2 Operating Instructions		6 Reference Materials	
A. Overfiring Your Appliance.	8	A. Service and Maintenance Log	22
B. Wood Selection & Storage	8	→ B. Service Parts	24
C. Burning Process.	8		
D. Burn Rates and Operating Efficiency.	9		
E. Building A Fire	11		
F. Opacity (Smoke)	12		
G. Clear Space	12		
H. Negative Pressure	13		
I. Frequently Asked Questions	13		

→ = Contains updated information

B. Warranty Policy

Hearth & Home Technologies, LLC

WoodPro Limited Warranty

Hearth & Home Technologies, LLC (HHT), on behalf of its WoodPro brand, extends the following warranty for WoodPro stoves purchased from an authorized retailer.

If you experience issues with your WoodPro stove, Consumer Care is available to assist you with troubleshooting technical issues.

This warranty covers components of the WoodPro stoves as listed in the table below.

Warranty Coverage:

Subject to the table below, HHT warrants to the owner of the WoodPro stove that the stove will be free from defects in materials and workmanship at the time of manufacture. After installation, if covered components are found to be defective in materials or workmanship during the applicable warranty period, HHT will replace the covered components. HHT, at its own discretion, may fully discharge all of its obligations under such warranties by replacing the product itself or refunding the verified purchase price of the product itself. The maximum amount recoverable under this warranty is limited to the purchase price of the product. This warranty is subject to conditions, exclusions, and limitations as described below.

Warranty Period: Warranty coverage begins on the date of original purchase. The warranty period for covered components is as follows:

Components Covered	Warranty Period (Parts only, Labor not included)
Steel Parts	5 Years
All steel replacement parts are covered for remainder of original 5-year warranty period or 90 days, whichever is longer.	90 Days

Parts Service & Returns: HHT is proud to offer the best technical and sales support in the industry. If you have any questions about how to operate your stove or if you need service parts, please visit ForgenFlame.com.

Warranty Exclusions: Warranty does not cover damage or breakage due to product misuse, improper handling or modifications. There is no warranty on the paint, glass, fire pot, fire brick, or any gaskets, or against damage caused from corrosion. There is no expressed or implied performance warranty on WoodPro units as HHT has no control over the installation, operation, cleaning, maintenance, or type of fuel burned.

Warranty is void if the WoodPro stove has not been installed, operated, cleaned and maintained in strict accordance with the guidance and instructions in the product manual.

THE REMEDIES DESCRIBED ABOVE ARE YOUR SOLE AND EXCLUSIVE REMEDIES AND THERE ARE NO WARRANTIES WHICH EXTEND BEYOND WHAT IS DESCRIBED HEREIN. HHT'S ENTIRE LIABILITY FOR ANY BREACH OF THIS LIMITED WARRANTY SHALL UNDER NO CIRCUMSTANCES EXCEED THE ACTUAL AMOUNT PAID FOR THE PRODUCT, NOR SHALL HHT UNDER ANY CIRCUMSTANCES BE LIABLE FOR ANY CONSEQUENTIAL, INCIDENTAL, SPECIAL OR PUNITIVE DAMAGES OR LOSSES, WHETHER DIRECT OR INDIRECT. SOME STATES DO NOT ALLOW THE EXCLUSION OR LIMITATION OF INCIDENTAL OR CONSEQUENTIAL DAMAGES, SO THE ABOVE LIMITATION OR EXCLUSION MAY NOT APPLY TO YOU. THIS LIMITED WARRANTY GIVES YOU SPECIFIC LEGAL RIGHTS AND YOU MAY HAVE OTHER RIGHTS, WHICH VARY FROM STATE TO STATE.

C. Quick Start Guide

Set-Up and First Fire

Note: These are generic drawings and may not represent your specific model.

Items needed for first fire: 10 Pieces of Newspaper, 10-20 Pieces of Dry Kindling and Few Pieces of Dry Split Wood.



Prior to first fire be sure to remove all packaging and labeling. Follow all clearance guidelines and read all safety warnings.

1

OPEN AIR CONTROLS

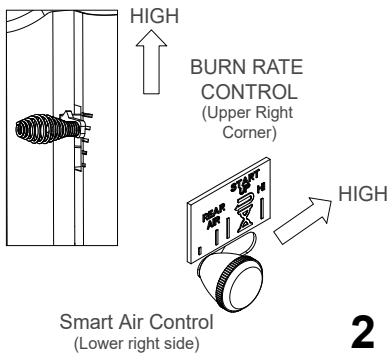

2

LOAD WOOD

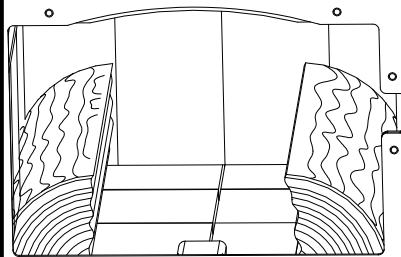

3

ADD NEWSPAPER

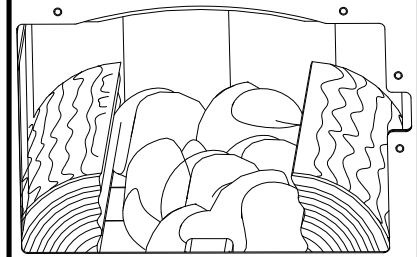

4

ADD KINDLING

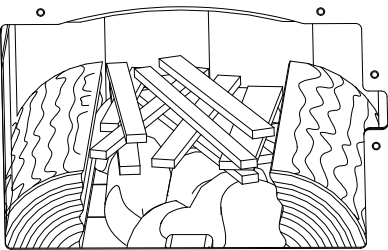

LIGHT THE PAPER

5

Warning! Risk of Fire.

Close and securely latch the door after the fire has started, and after refueling, to prevent:

- Spillage of smoke, flame and carbon monoxide
- Spillage of sparks, coals, and logs
- Overfiring

DO NOT leave the appliance unattended with the door open.

Starting a fire may not require an open door for draft. The air control should supply adequate draft.

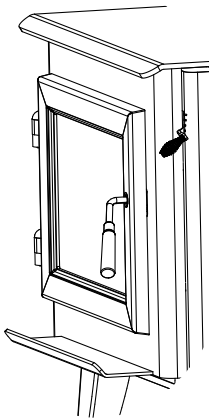

6

ADD MORE WOOD

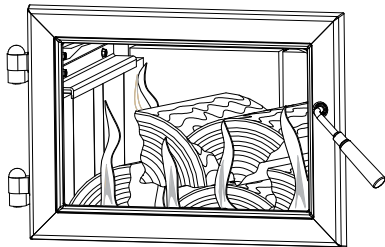

7

REDUCE AIR CONTROLS

Set to desired heat output.

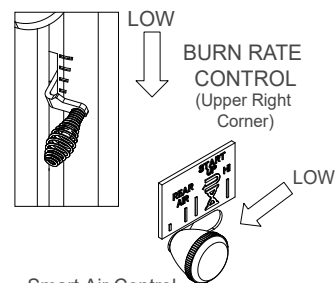

8

The appliance is ready for normal operation.

1 Listing and Code Approvals

A. Appliance Safety Certification

Model Number:	FF-WP-200
Laboratory:	PFS-TECO
Report Number:	24-338
Type:	Listed Room Appliance, Solid Fuel Type
Standard:	UL1482 and ULC S627-00 and (UM) 84-HUD, Mobile Home Approved.

B. Appliance Emissions Certification

Model Number:	FF-WP-200
Laboratory:	PFS-TECO
Report Number:	24-338
Standard:	ASTM E2515, ASTM E2780

The WP-200 is Certified to comply with 2020 crib wood particulate emission standards.



This wood appliance needs periodic inspection and repair for proper operation. It is against federal regulations to operate this wood appliance in a manner inconsistent with operating instructions in this manual.

NOTE: This installation must conform with local codes. In the absence of local codes you must comply with **(UM) 84-HUD and NFPA211 in the U.S.A. and CAN/CSA-B365 Installation Codes in Canada.**

C. BTU & Efficiency Specifications

EPA Certification Number:	Number: 86-17
EPA Certified Emissions:	1.9 grams per hour
*LHV Tested Efficiency:	78.3%
**HHV Tested Efficiency:	72.5%
***EPA BTU Output:	13,900 to 29,100 / hr
****Peak BTU/Hour Output:	51,000
Vent Size:	6 inches
Firebox Size:	1.89 cubic feet
Recommended Log Length:	16 inches
Fuel:	Seasoned Cord Wood (20% moisture)
* Weighted average LHV (Low Heating Value) efficiency using Douglas Fir dimensional lumber and data collected during EPA emission tests in accordance with the requirements of CSA B415.1. LHV assumes the moisture is already in a vapor state so there is no loss in energy to vaporize.	
** Weighted average HHV (High Heating Value) efficiency using Douglas Fir dimensional lumber and data collected during EPA emission tests in accordance with the requirements of CSA B415.1. HHV includes the energy required to vaporize the water in the fuel.	
*** A range of BTU outputs calculated using HHV Efficiency and the burn rates from the EPA tests, using Douglas Fir dimensional lumber.	
**** A peak BTU out of the appliance calculated using the maximum first hour burn rate from the High EPA Test and BTU content of seasoned cordwood (8600) times the efficiency.	

D. Glass Specifications

This appliance is equipped with 5mm ceramic glass. Replace glass only with 5mm ceramic glass.

E. Mobile Home Approved

- This appliance is approved for mobile home installations when not installed in a sleeping room and when an outside combustion air inlet is provided.
- The structural integrity of the mobile home floor, ceiling, and walls must be maintained.
- The appliance must be properly grounded to the frame of the mobile home with #8 copper ground wire, and chimney must be listed to **UL103 HT or a listed UL-1777** full length six inch (152mm) diameter liner must be used.
- Outside Air Kit, part OAK-ACC must be installed in a mobile home installation. **Note:** Shipping brackets are also used as Mobile Home brackets.

F. Sleeping Room

When installed in a sleeping room it is recommended that a smoke and/or CO alarm be installed in the bedroom. The size of the room must be at least 50ft³ per 1,000 Btu/hr stove input, if the stove exceeds the room size, outside air must be installed.

G. California - Prop65

WARNING

This product and the fuels used to operate this product (wood), and the products of combustion of such fuels, can expose you to chemicals including carbon black, which is known to the State of California to cause cancer, and carbon monoxide, which is known to the State of California to cause birth defects or other reproductive harm. For more information go to: WWW.P65Warnings.ca.gov



WARNING



Fire Risk.

Hearth & Home Technologies disclaims any responsibility for, and the warranty will be voided by, the following actions:

- Installation and use of any damaged appliance.
- Modification of the appliance.
- Installation other than as instructed by Hearth & Home Technologies.
- Installation and/or use of any component part not approved by Hearth & Home Technologies.
- Operating appliance without fully assembling all components.
- Operating appliance without legs attached (if supplied with appliance).
- **Do NOT Over fire** - If appliance or chimney connector glows, you are over firing.

Any such action that may cause a fire hazard.

Improper installation, adjustment, alteration, service or maintenance can cause injury or property damage.

For assistance or additional information, consult a qualified installer or service agency.



Hearth & Home Technologies WILL NOT warranty stoves that exhibit evidence of overfiring. Evidence of overfiring includes, but is not limited to:

- Warped air tube
- Deteriorated refractory brick retainers
- Deteriorated baffle and other interior components

NOTE: Hearth & Home Technologies, manufacturer of this appliance, reserves the right to alter its products, their specifications and/or price without notice.

2 Operating Instructions

A. Overfiring Your Appliance

	WARNING
	<p>Fire Risk. Do not over-fire. Overfiring may ignite creosote or will damage the appliance and chimney. To prevent overfiring your appliance, <u>DO NOT</u>:</p> <ul style="list-style-type: none">• Use flammable liquids• Overload with wood• Burn trash or large amounts of scrap lumber• Permit too much air to the fire

1. Symptoms of Overfiring

Symptoms of overfiring may include one or more of the following:

- Chimney connector or appliance glowing
- Roaring, rumbling noises
- Loud cracking or banging sounds
- Metal warping
- Chimney fire

2. What To Do if Your Appliance is Overfiring

- Immediately close the door and air controls to reduce air supply to the fire.
- If you suspect a chimney fire, call the fire department and evacuate your house.
- Contact your local chimney professional and have your appliance and appliance pipe inspected for any damage.
- Do not use your appliance until the chimney professional informs you it is safe to do so.

Hearth & Home Technologies WILL NOT warranty appliances that exhibit evidence of overfiring. Evidence of overfiring includes, but is not limited to:

- Warped air tube
- Deteriorated refractory brick retainers
- Deteriorated baffle and other interior components

B. Wood Selection & Storage

Burn only dry seasoned wood. Store wood under cover, out of the rain and snow. Dry and well-seasoned wood will not only minimize the chance of creosote formation, but will give you the most efficient fire. Even dry wood contains at least 15% moisture by weight, and should be burned hot enough to keep the chimney hot for as long as it takes to dry the wood out - about one hour. It is a waste of energy to burn unseasoned wood of any kind.

Dead wood lying on the forest floor should be considered wet, and requires full seasoning time. Standing dead wood can be considered to be about 2/3 seasoned. To tell if wood is dry enough to burn, check the ends of the logs. If there are cracks radiating in all directions from the center, it is dry. If your wood sizzles in the fire, even though the surface is dry, it may not be fully cured.

Splitting wood before it is stored reduces drying time. Wood should be stacked so that both ends of each piece are exposed to air, since more drying occurs through the cut ends than the sides. This is true even with wood that has been split. Store wood under cover, such as in a shed, or covered with a tarp, plastic, tar paper, sheets of scrap plywood, etc., as uncovered wood can absorb water from rain or snow, delaying the seasoning process.

C. Burning Process

In recent years there has been an increasing concern about air quality. Much of the blame for poor air quality has been placed on the burning of wood for home heating. In order to improve the situation, we at Forge & Flame have developed cleaner-burning wood appliances that surpass the requirements for emissions established by our governing agencies. These wood appliances, like any other appliances, must be properly operated in order to insure that they perform the way they are designed to perform. Improper operation can turn most any wood appliance into a smoldering environmental hazard.

1. **Kindling or First Stage:** It helps to know a little about the actual process of burning in order to understand what goes on inside a appliance. The first stage of burning is called the kindling stage. In this stage, the wood is heated to a temperature high enough to evaporate the moisture which is present in all wood. The wood will reach the boiling point of water (212°F) and will not get any hotter until the water is evaporated. This process takes heat from the coals and tends to cool the appliance.

Fire requires three things to burn; fuel, air and heat. So, if heat is robbed from the appliance during the drying stage, the new load of wood has reduced the chances for a good clean burn. For this reason, it is always best to burn dry, seasoned firewood. When the wood isn't dry, you must open the air controls and burn at a high burn setting for a longer time to start it burning. The heat generated from the fire should be warming your home and establishing the flue draft, not evaporating the moisture out of wet, unseasoned wood, resulting in wasted heat.

2. **Second Stage:** The next stage of burning, the secondary stage, is the period when the wood gives off flammable gases which burn above the fuel with bright flames. During this stage of burning it is very important that the flames be maintained and not allowed to go out. This will ensure the cleanest possible fire. If the flames tend to go out, it is set too low for your burning conditions. The air control located at the upper right hand corner is used to adjust for burn rates. This is called the Burn Rate Air Control (Figure 9.1).

3. **Final Stage:** The final stage of burning is the charcoal stage. This occurs when the flammable gases have been mostly burned and only charcoal remains. This is a naturally clean portion of the burn. The coals burn with hot blue flames.

It is very important to reload your appliance while enough lively hot coals remain in order to provide the amount of heat needed to dry and rekindle the next load of wood. It is best to open the Burn Rate Air and Smart Air Control before reloading. This livens up the coal bed and reduces excessive emissions (opacity/smoke). Open door slowly so that ash or smoke does not exit appliance through opening. You should also break up any large chunks and distribute the coals so that the new wood is laid on hot coals.

Air quality is important to all of us, and if we choose to use wood to heat our homes we should do so responsibly. To do this we need to learn to burn our appliances in the cleanest way possible. Doing this will allow us to continue using our wood appliances for many years to come.

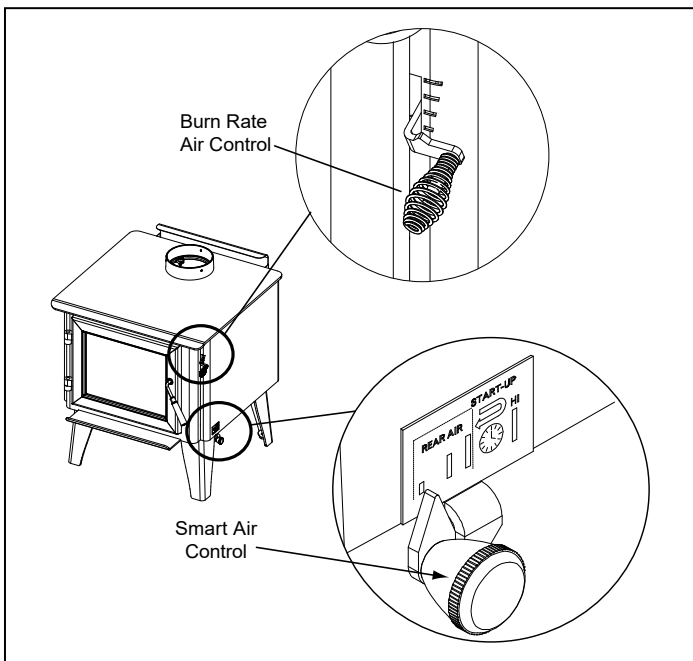

Figure 9.1

D. Burn Rates and Operating Efficiency

For maximum operating efficiency

This wood appliance has a manufacturer-set minimum low burn rate that must not be altered. It is against federal regulations to alter this setting or otherwise operate this wood appliance in a manner inconsistent with operating instructions in this manual.

- Burn dry, well-seasoned wood.

Burn Rates

1. Low burn setting:

- Burn Rate Air Control spring handle up to high position for 5 minutes.
- Then activate the Smart Air Control by pushing the knob all the way back toward the appliance to “HI” then pull forwards towards the front of the appliance until the knob stops (**Figure 9.1**).
- At that point close the Burn Rate Air Control by moving the spring handle to the low setting.

2. Medium low burn setting:

- Burn Rate Air Control spring handle up to high position for 5 minutes.
- Then activate the Smart Air Control by pushing the knob all the way back toward the appliance to “HI” then pull forwards towards the front of the appliance until the knob stops.
- At that point move the Burn Rate Air Control spring handle to 1/8”-1/2” from the low setting.

3. Medium high burn setting:

- Burn Rate Air Control spring handle up to high position.
- Then activate the Smart Air Control by pushing the knob all the way back toward the appliance to “HI” then pull forwards towards the front of the appliance until the knob stops.
- At that point move the Burn Rate Air Control spring handle to 1/2” – high.

4. High burn setting:

- Burn Rate Air Control spring handle up to high position
- Also activate Smart Air Control knob pushed back to the “HI” position.

Surface Thermometer is a Valuable Guide to Operation

A surface thermometer tells you when to adjust the air control, and when to refuel.

For example, when the thermometer registers at least 450°F (230°C) on the stove top after start-up you know the stove is hot enough and it may be time to adjust the air control if a sufficient ember bed has also been established. Note that the stove will warm up much sooner than the chimney, though; a warm chimney is the key to easy, effective stove operation. When thermometer readings drop below 350°F. (175°C) it's time to adjust the air control for a higher burn rate or to reload the stove. A temperature reading over 650°F. (340°C) is a sign to reduce the air supply to slow the burn rate.

Use the following temperature ranges as a guide:

- Readings in the 350°-500°F. (175°-260°C) range indicate low to medium heat output.
- 500°-600°F. (260°-315°C) readings indicate medium heat output.
- Readings of 600°-650°F. (315-340°C) indicate high heat output. Operating your wood stove continuously at stove top temperatures higher than 650° F (340°C) may damage your wood stove.

NOTE: The above information is provided as a guideline only. Altitude and other circumstances may require control adjustments to achieve the desired burn rates.

NOTE: Operate appliance on High Burn 45 minutes a day to help keep flue/chimney clean.

WARNING



Risk of Fire.

When set on High Burn Rate and over-riding the Smart Air Control an over fire situation can occur and may result in a chimney fire. Over firing will void the appliance warranty.

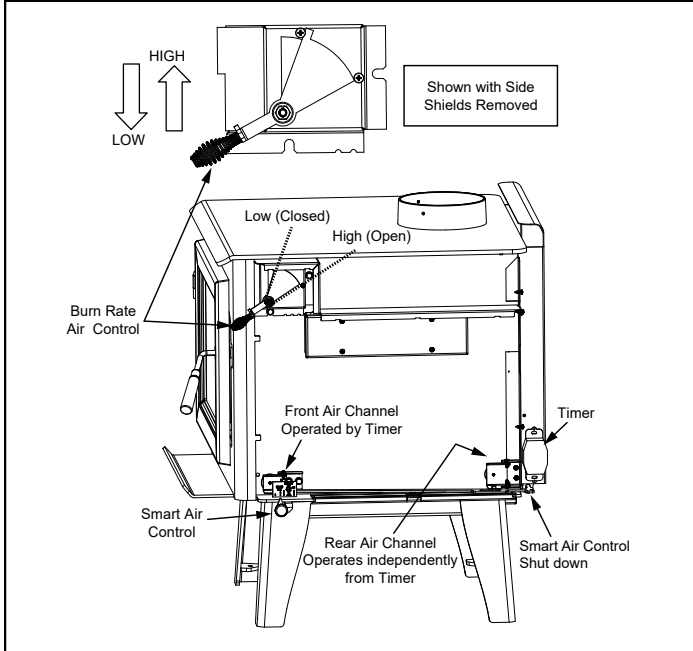

Figure 10.1

After activating the timer (Smart Air Control), if the control is placed within the rear air section on the label it will allow rear air to enter the firebox. This will not interfere with the timer gradually closing the front air channel in 25 minutes. If the control is set to "HI", it overrides the Smart Air Control timer and keeps the front air channel from closing.

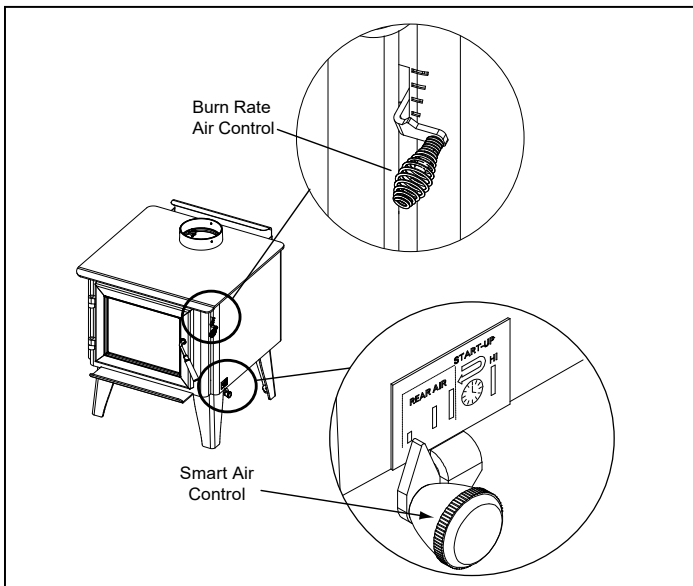

Figure 10.2

CAUTION



Injury Risk.

- Gloves recommended

Manual Timer Override: If you need to shut the Smart Air Control off before it goes through the cycle of shutting itself off; 25 minutes, reach towards the back of the appliance on the right side and pull the lever towards the front of the appliance (Figure 10.3).

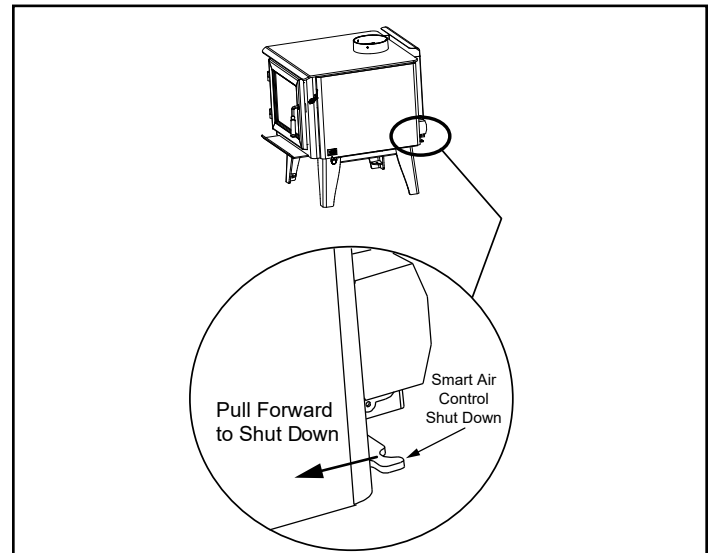

Figure 10.3

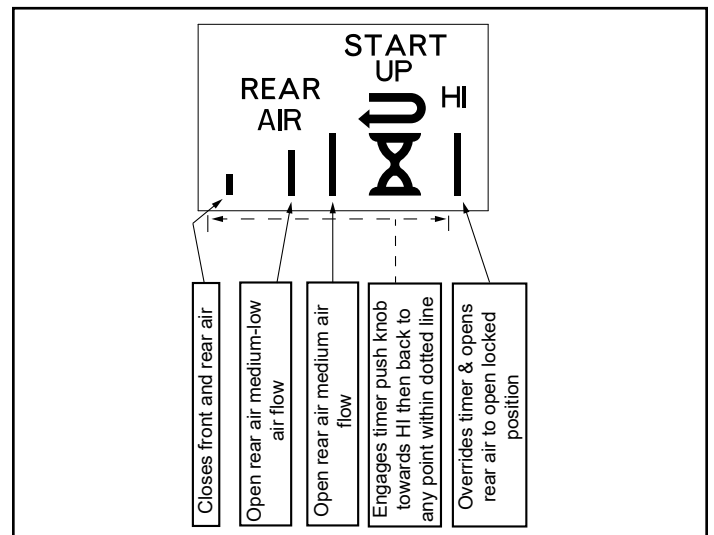

Figure 10.4

E. Building A Fire

Before lighting your first fire in the appliance:

NOTE: The special high temperature paint that your appliance is finished with will cure as your appliance heats. You will notice an odor and perhaps see some vapor rise from the appliance surface; this is normal. We recommend that you open a window until the odor dissipates and paint is cured.

1. Confirm the baffle is correctly positioned. It should be even with the front tube and resting on all tubes (**Figure 11.1 and Figure 11.2**).

2. Remove all labels from glass and inside of appliance.

There are many ways to build a fire. The basic principle is to light easily-ignitable tinder or paper, which ignites the fast burning kindling, which in turn ignites the slow-burning firewood. Here is one method that works well:

1. Open the Burn Rate Air and Smart Air Controls fully (Refer to the **Quick Start Guide**).

2. Place several wads of crushed paper on the firebox floor. Heating the flue with slightly crumpled newspaper before adding kindling keeps smoke to a minimum.

3. Lay small dry sticks of kindling on top of the paper.

4. Make sure that no matches or other combustibles are in the immediate area of the appliance. Be sure the room is adequately ventilated and the flue unobstructed.

5. Light the paper in the appliance. NEVER light or rekindle fire with kerosene, gasoline, or charcoal lighter fluid; the results can be fatal.

6. Once the kindling is burning quickly, add several full-length logs 3 inches (76mm) or 4 inches (102mm) in diameter. Be careful not to smother the fire. Stack the pieces of wood carefully; near enough to keep each other hot, but far enough away from each other to allow adequate air flow between them.

7. Set the Burn Rate Air Control and activate the Smart Air Control.

8. When ready to reload, it is best to fully open both the Burn Rate Air and Start-up Air Controls **before reloading**. This livens up the coal bed and reduces excessive emissions (opacity/smoke). Open door slowly so that ash or smoke does not exit appliance through opening. Large logs burn slowly, holding a fire longer. Small logs burn fast and hot, giving quick heat.

9. As long as there are hot coals, repeating steps 6 through 8 will maintain a continuous fire.



WARNING



Fire Risk.

- Do not leave the fire unattended when the door is unlatched.
- Unstable firewood could fall out of the firebox creating a fire hazard to your home.

NOTE:

- Build fire on brick firebox floor.
- Do NOT use grates, andirons or other methods to support fuel. It will adversely affect emissions.



WARNING



Fire Risk.

Do NOT store wood:

- Closer than required clearances to combustibles to appliance
- Within space required for loading or ash removal.

Do NOT operate appliance:

- With appliance door open.

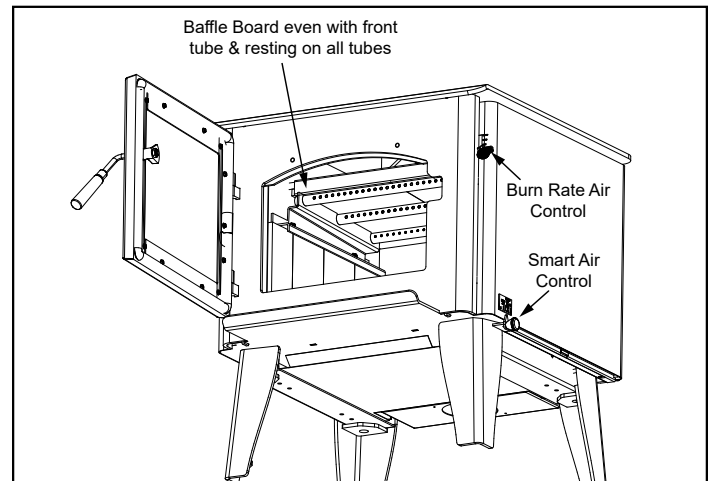

Figure 11.1

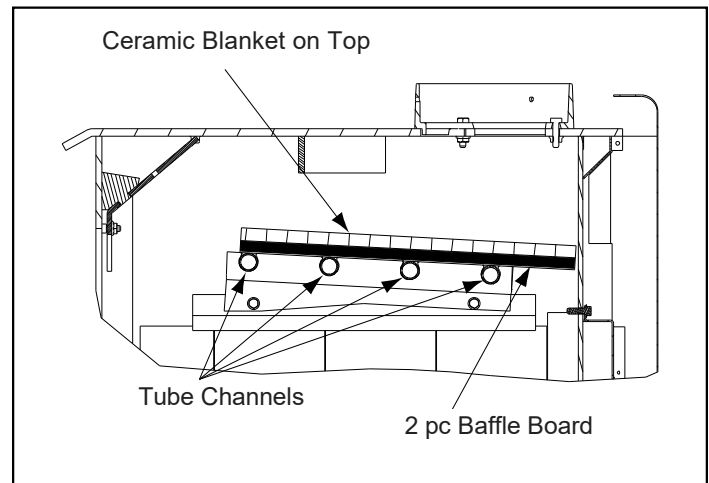

Figure 11.2



WARNING







Fire Risk.

- Do NOT burn wet or green wood.
 - Store wood in dry location.
 - Stack wood so both ends are exposed to air.
- Wet, unseasoned wood can cause accumulation of creosote.

F. Opacity (Smoke)

This is the measure of how cleanly your appliance is burning. Opacity is measured in percent; 100% opacity is when an object is totally obscured by the smoke column from a chimney, and 0% opacity means that no smoke column can be seen. As you become familiar with your appliance, you should periodically check the opacity. This will allow you to know how to burn as nearly smoke-free as possible (goal of 0% opacity).

 WARNING	
	Fire Risk.
	• DO NOT BURN GARBAGE OR FLAMMABLE FLUIDS SUCH AS GASOLINE, NAPHTHA OR ENGINE OIL.
	• Do NOT burn treated wood or wood with salt (driftwood).
	• May generate carbon monoxide if burn material other than wood.
	• May result in illness or possible death.

 WARNING	
	Fire Risk.
	Keep combustible materials, gasoline and other flammable vapors and liquids clear of appliance.
	• Do NOT store flammable materials in the appliance's vicinity.
	• DO NOT USE GASOLINE, LANTERN FUEL, KEROSENE, CHARCOAL LIGHTER FLUID OR SIMILAR LIQUIDS TO START OR "FRESHEN UP" A FIRE IN THIS Appliance.
	• Keep all such liquids well away from the appliance while it is in use.
• Combustible materials may ignite.	

 CAUTION	
When burning your first fire, you will experience smoke and odor from the appliance resulting from the curing of paint and burning off of any oils remaining from manufacturing.	
OPEN WINDOWS DURING INITIAL BURN TO DISSIPATE SMOKE AND ODORS!	
• Odors may be irritating to sensitive individuals.	
• Smoke detectors may activate.	

G. Clear Space

NOTE: Do NOT place combustible objects within 4 ft (1.2m) of the front of appliance (**Figure 13.1**).

- **Mantel:** Avoid placing candles and other heat-sensitive objects on mantel or hearth. Heat may damage these objects.

 WARNING	
Do NOT place combustible objects in front of the appliance. High temperatures may ignite clothing, furniture or draperies.	

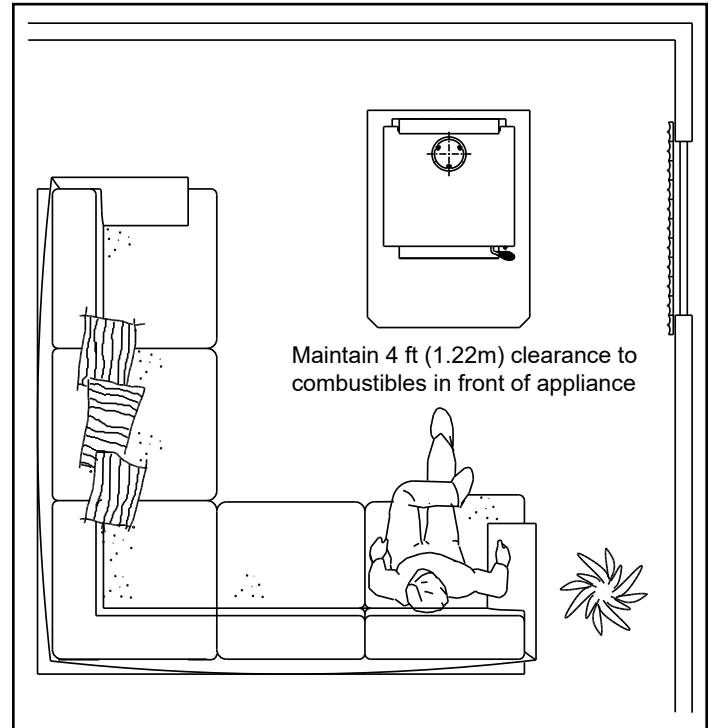



Figure 12.1

H. Negative Pressure

 WARNING	
	<p>Asphyxiation Risk.</p> <ul style="list-style-type: none"> Negative pressure can cause spillage of combustion fumes, soot and carbon monoxide. Appliance needs to draft properly for safety.

Negative pressure results from the imbalance of air available for the appliance to operate properly. It can be strongest in lower levels of the house.

Causes include:

- Exhaust fans (kitchen, bath, etc.)
- Range hoods
- Combustion air requirements for furnaces, water appliances and other combustion appliances
- Clothes dryers
- Location of return-air vents to furnace or air conditioning
- Imbalances of the HVAC air handling system
- Upper level air leaks such as:
 - Recessed lighting
 - Attic hatch
 - Duct leaks



To minimize the effects of negative air pressure:



- Install the outside air kit with the intake facing prevailing winds during the heating season
- Ensure adequate outdoor air for all combustion appliances and exhaust equipment
- Ensure furnace and air conditioning return vents are not located in the immediate vicinity of the appliance
- Avoid installing the appliance near doors, walkways or small isolated spaces
- Recessed lighting should be a “sealed can” design
- Attic hatches weather stripped or sealed
- Attic mounted duct work and air handler joints and seams taped or sealed

I. Frequently Asked Questions

ISSUES	SOLUTIONS
Odor from appliance	When first operated, this appliance may release an odor for the first several hours. This is caused by the curing of the paint and the burning off of any oils remaining from manufacturing.
Metallic noise	Noise is caused by metal expanding and contracting as it heats up and cools down, similar to the sound produced by a furnace or heating duct. This noise does not affect the operation or longevity of the appliance.

Table 13.1

 WARNING	
	<p>Fire Risk.</p> <ul style="list-style-type: none"> DO NOT BURN GARBAGE OR FLAMMABLE FLUIDS SUCH AS GASOLINE, NAPHTHA OR ENGINE OIL. Do NOT burn treated wood or wood with salt (driftwood). May generate carbon monoxide if burn material other than wood. <p>May result in illness or possible death.</p>

 WARNING	
	<p>Fire Risk.</p> <p>Keep combustible materials, gasoline and other flammable vapors and liquids clear of appliance.</p> <ul style="list-style-type: none"> Do NOT store flammable materials in the appliance's vicinity. DO NOT USE GASOLINE, LANTERN FUEL, KEROSENE, CHARCOAL LIGHTER FLUID OR SIMILAR LIQUIDS TO START OR “FRESHEN UP” A FIRE IN THIS APPLIANCE. Keep all such liquids well away from the appliance while it is in use. Combustible materials may ignite.

3 Maintenance and Service

A. Quick Reference Maintenance Guide

When properly maintained, your fireplace will give you many years of trouble-free service.



CAUTION

Allow the appliance to completely cool down before performing any cleaning or maintenance. Start the first inspection after the first 2 months of use, or if performance changes, and adjust your schedule accordingly. Maintenance is required for safe operation and must be performed to maintain your warranty.

	FREQUENCY	TASK
<p>Baffle & Blanket</p>	<p>MONTHLY or after every one (1) cord of wood</p>	<p>Baffle and blanket placement is critical to heat output, efficiency and overall life of the appliance. Make sure the baffle is pushed all of the way to the back of the firebox and the blanket is laying flat. Inspect baffle for cracks.</p>
<p>Chimney System</p>	<p>EVERY TWO MONTHS or after every four (4) cords of wood</p>	<p>The chimney and chimney cap must be inspected for soot and creosote every two months during the burn season or more frequency if chimney exceeds or is under 14-16 ft (4.3m-4.8m) measured from bottom of appliance.</p> <p>This will prevent pipe blockage, poor draft, and chimney fires. Always burn dry wood to help prevent cap blockage and creosote build-up.</p>
<p>Firebrick & Ash Removal</p>	<p>WEEKLY or after every 25 loads of wood</p>	<p>Ashes must be cool before you can dispose of the ashes in a non-combustible container.</p> <p>Firebrick is designed to protect your firebox. After ashes are removed, inspect the firebrick and replace firebricks that are crumbling, cracked or broken.</p>
<p>Door & Glass Assemblies</p>	<p>WEEKLY or after every 25 loads of wood</p>	<p>Keep door and glass gasket in good shape to maintain good burn. <u>To test:</u> place a dollar bill between the appliance and door and then shut the door. If you can pull the dollar out, remove one washer from door handle behind latch cam and try again. If you can still pull it out, replace the door gasket.</p> <p>Check the glass frame for loose screws to prevent air leakage.</p> <p>Check glass for cracks.</p>
<p>Door Handles</p>	<p>WEEKLY or after every 25 loads of wood</p>	<p>Check the door latch for proper adjustment. This is very important especially after the door rope has formed to the appliance face.</p> <p>Check door handle for smooth cam operation.</p>

These are generic drawings and may not represent your model.

Table 14.1

B. General Maintenance

1. Creosote (Chimney) Cleaning

- **Frequency:** Every 2 months during heating season or as recommended by a certified chimney sweep; more frequently if chimney exceeds or is under 14-16 ft. (measured from bottom of appliance)
- **By:** Certified Chimney Sweep

Remove all ash from the firebox and extinguish all hot embers before disposal. Allow the appliance to cool completely. Disconnect flue pipe or remove baffle and ceramic blanket from appliance before cleaning chimney. Otherwise residue can pile up on top of the baffle and ceramic blanket and the appliance will not work properly. (See section 5E **Baffle Removal**). Close the door tightly. The creosote or soot should be removed with a brush specifically designed for the type of chimney in use. Clean out fallen ashes from the firebox.



It is also recommended that before each heating season the entire system be professionally inspected, cleaned and repaired if necessary.



Inspection: Inspect the system at the appliance connection and at the chimney top. Cooler surfaces tend to build creosote deposits quicker, so it is important to check the chimney from the top as well as from the bottom.

Formation and Need For Removal: When wood is burned slowly, it produces tar and other organic vapors which combine with expelled moisture to form creosote.

The creosote vapors condense in the relatively cool chimney flue of a newly-started or a slow-burning fire. As a result, creosote residue accumulates on the flue lining. When ignited, this creosote creates an extremely hot fire which may damage the chimney or even destroy the house.

The chimney connector and chimney should be inspected once every 2 months during the heating season to determine if a creosote or soot buildup has occurred. If creosote or soot has accumulated, it should be removed to reduce the risk of a chimney fire.

 WARNING	
	Fire Risk. Prevent creosote buildup.
	<ul style="list-style-type: none">• Inspect chimney connector and chimney once every two months during heating season.• Remove creosote to reduce risk of chimney fire.• Ignited creosote is extremely HOT.



 WARNING	
	Fire Risk.
	<ul style="list-style-type: none">• Do not use chimney cleaners or flame colorants in your appliance. Will corrode chimney pipe.

2. Disposal of Ashes

- **Frequency:** When ash is within 1-3/4 in. (44mm) of firebox lip
- **By:** Homeowner

 WARNING	
	Fire Risk. Ashes could contain hot embers.

Ashes should be placed in a metal container with a tight fitting lid. The closed container of ashes should be placed on a non-combustible floor or on the ground, well away from all combustible materials, pending final disposal. If the ashes are disposed of by burial in soil or otherwise locally dispersed, they should be retained in the closed container until all cinders have thoroughly cooled.

 WARNING	
	Fire Risk. Disposal of Ashes
	<ul style="list-style-type: none">• Ashes should be placed in metal container with tight fitting lid.• Do not place metal container on combustible surface.• Ashes should be retained in closed container until all cinders have thoroughly cooled.

3. Appliance Inspection

- **Frequency:** Every 2 months at the same time the chimney and chimney connector are inspected.
- **By:** Homeowner

Check for:

- Cracks in glass
- Door handle - smooth cam operation
- Baffle and ceramic blanket correct placement
- Baffle for warpage
- Firebrick for cracks, broken or crumbly
- Door gasket (Dollar bill test): Place a dollar bill between the stove and the door and then shut the door. If you can pull the dollar bill out, replace the door gasket.
- Glass frame for loose screws

4. **Glass Cleaning**

- **Frequency:** As desired
- **By:** Homeowner

 CAUTION
Handle glass assembly with care. Glass is breakable. <ul style="list-style-type: none">• Avoid striking, scratching or slamming glass• Avoid abrasive cleaners• Do not clean glass while it is hot

Clean glass with a non-abrasive glass cleaner. Abrasive cleaners may scratch and cause glass to crack. If the deposits on the glass are not very heavy, normal glass cleaners work well. Heavier deposits may be removed by using a damp cloth dipped in wood ashes or by using a commercially available oven cleaner.

After using an oven cleaner, it is advisable to remove any residue with a glass cleaner or soap and water. Oven cleaner left on during the next firing can permanently stain the glass and damage the finish on metal surfaces.

A portion of the combustion air entering the firebox is deflected down over the inside of the door glass. This air flow “washes” the glass, helping to keep smoke from adhering to its surface.

When operated at a low burn rate, less air will be flowing over the glass and the smokey, relatively cool condition of a low fire will cause the glass to become coated.

Operating the appliance with the Burn Rate Air Control and Smart Air Control all the way open for 30-45 minutes should remove the built up coating.

 CAUTION
<ul style="list-style-type: none">• Do not use polishes with abrasives. It will scratch surfaces.

5. **Cleaning Plated Surfaces**

- **Frequency:** Prior to first burn and then as desired
- **By:** Homeowner

Clean all the fingerprints and oils from plated surfaces **BEFORE** firing the appliance for the first time. If not cleaned properly before lighting your first fire, the oils can cause permanent markings on the plating.

After the plating is cured, the oils will not affect the finish and little maintenance is required. Wipe clean as needed.

 CAUTION
<ul style="list-style-type: none">• Do not use polishes with abrasives. It will scratch plated surfaces.

6. **Inspect Firebrick**

- **Frequency:** After each ash removal
- **By:** Homeowner

Replace the firebrick if they become crumbly and/or if there is a 1/4 inch (6.35mm) gap between the bricks.

The firebox is lined with firebrick, which has exceptional insulating properties. Do not use a grate; simply build a fire on the firebox floor. Do not operate appliance without firebrick.

1. After the coals have completely cooled, remove all old brick and ash from unit and vacuum firebox.
2. Remove new brick set from box and lay out to the diagram shown in the instructions that come with the brick set or refer to the diagram on the service parts list at the end of this manual.
3. Lay bottom bricks in unit.
4. Install rear bricks on the top of the bottom bricks. Slide top of bricks under clip on back of firebox wall and push bottom of bricks back.
5. Install side bricks. Slide top of brick under clips on side of firebox and push the bottom of the brick until it is flush with the side of the unit.

C. Correct Baffle & Blanket Placement



WARNING



Fire Risk.

Firebox damage due to improper baffle placement is not covered by warranty. Operate the wood burning appliance with the baffle in the correct position only.

Not doing so could result in:

- Reduced efficiency
- Overheating the chimney
- Overheating the rear of the firebox
- Poor performance

Ensure correct baffle placement and replace baffle components if damaged or missing.



CAUTION

The baffle boards are **FRAGILE**. Use extreme caution when loading firewood to prevent:

- Cracking, breaking or damaging the baffle boards
- DO NOT** operate the appliance without baffle boards

CORRECT POSITION

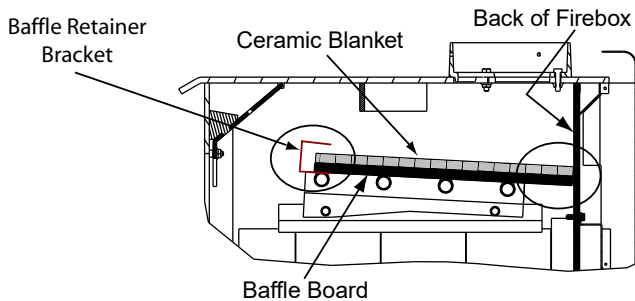

Ceramic Blanket and Baffle Board **MUST** be in contact with the back of the firebox and even with each other in the front.

Figure 17.1

INCORRECT POSITIONS

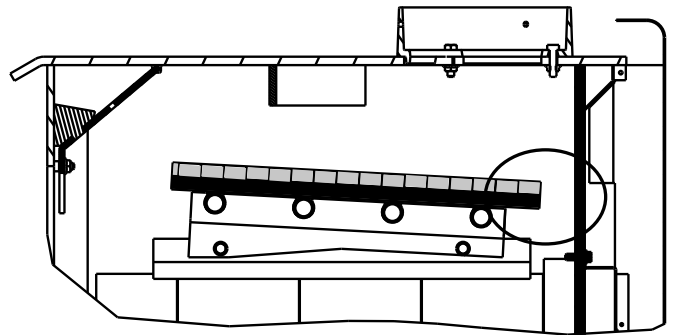

Ceramic Blanket and Baffle Board are **NOT** in contact with the back of the firebox.

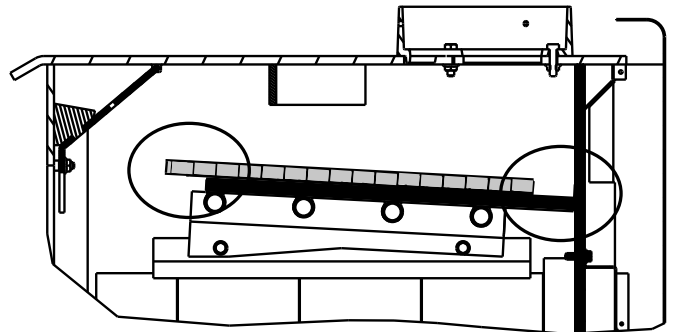

Ceramic Blanket is **NOT** in contact with the back of the firebox and **NOT** even with the Baffle Board in the front.

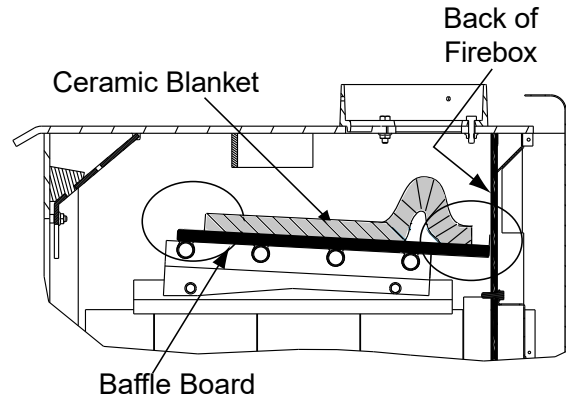

Ceramic Blanket is bunched up at the back of the firebox and **NOT** even with the Baffle Board in the front.

Figure 17.2

4 Troubleshooting Guide

With proper installation, operation, and maintenance your wood appliance will provide years of trouble-free service. If you do experience a problem, this troubleshooting guide will assist you or a qualified service person in the diagnosis of a problem and the corrective action to be taken.

Start Fire Problems	Possible Cause	Solution
Can not get fire started Excessive smoke or spillage Burns too slowly Not enough heat output	Not enough kindling/paper or no kindling/paper	Use dry kindling, more paper. Arrange kindling & wood for air movement.
	Not enough air for fire to ignite	Check for restricted termination cap
		Check for blockage of outside air kit (if installed).
		Check for flue blockage.
		Pre-warm flue before starting fire (refer to section 2E Building a Fire).
		Check for adequate vent height (refer to section Chimney Height / Rise and Run of the Installation manual).
	Open window below the appliance towards the wind.	
	Wood condition is too wet, too large	Use dry, seasoned wood (refer to section 2B Wood Selection and Storage).
	Bed of coals not established before adding wood	Start with paper & kindling to establish bed of coals (refer to section 2E Building a Fire).
Flue blockage such as birds' nests or leaves in termination cap	Have chimney inspected for creosote and cleaned by a certified chimney sweep.	
Down draft or negative pressure Competition with exhaust devices	Do not use exhaust fans during start-up (refer to section 2H Negative Pressure).	
	Open window below the appliance towards the wind.	
Fire burns too fast	Extremely dry or soft wood	Mix in hardwood.
		Mix in less seasoned wood after fire is established (refer to section 2B Wood Selection and Storage).
	Over drafting	Check for correct vent height; too much vertical height creates over drafting.
Check location of vent termination (refer to section Chimney Termination Requirements of the Installation manual).		

Table 18.1

5 Service Part Replacement

A. Glass

NOTE: Replace with 5mm ceramic glass only.

Service Part: SRV7044-027

1. Ensure that the fire is out and the appliance is cool to the touch.
2. Protect a table or counter top with padding or towels. Protect your hands and wear gloves to prevent injury.
3. Remove the door with the broken glass by lifting the door up and off of the hinges.
4. Lay door face down on a table or counter making sure the handle hangs over the edge so the door lays flat, on a soft surface.
5. Remove the screws from each glass retainer and remove the glass. (If screws are difficult to remove, soak with penetrating oil first).
6. Center the glass with edges evenly overlapping the opening in the door, (i.e. same space top and bottom, left and right sides).
7. Replace the glass retainers. Be careful not to cross thread the screws.
8. Tighten each retainer just a few turns until each is secured. Check again for centering of glass in door frame. Continue to tighten each retainer alternately, a few turns at a time, until the glass is secure.

NOTE: DO NOT OVER TIGHTEN RETAINERS - can cause glass to break.

9. Replace the door on the appliance. Forge & Flame appliances are equipped with ceramic super heat-resistant glass, which can only be broken by impact or misuse.

WARNING



Injury Risk.

- Use only glass specified in manual.
- DO NOT REPLACE with any other material.

CAUTION

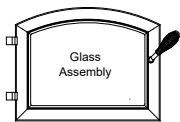

Handle glass assembly with care.
When cleaning glass:

- Avoid striking, scratching or slamming glass.
- Do NOT clean glass when hot.
- Do NOT use abrasive cleaners.
- Use a hard water deposit glass cleaner on white film.
- Use commercial oven cleaner on heavier deposits.
- Remove all residue of oven cleaner or will permanently stain glass on next firing.

Refer to maintenance instructions.

B. Firebrick

Service Part: SRV7033-006

Replace the firebrick if they become crumbly and/or if there is a 1/4 inch (6.35mm) gap between the bricks.

Inspect the firebrick after each ash removal.

The firebox is lined with high quality firebrick, which has exceptional insulating properties. There is no need to use a grate; simply build a fire on the firebox floor. Do not operate appliance without firebrick.

1. After the coals have completely cooled, remove all old brick and ash from appliance and vacuum firebox.
2. Remove new brick set from box and lay out to diagram shown.
3. Lay bottom bricks in appliance.
4. Install rear bricks on the top of the bottom bricks. Slide top of bricks under clip on back of firebox wall and push bottom of brick back.
5. Install side bricks. Slide top of brick under clips on side of firebox and push the bottom of the brick until it is flush with the side of the appliance.

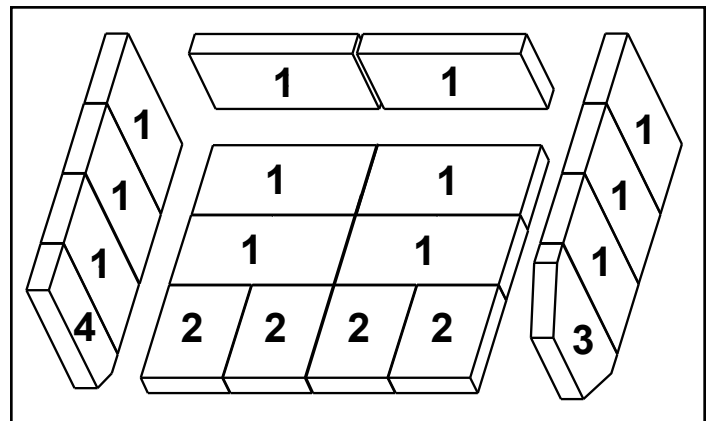

Figure 19.1

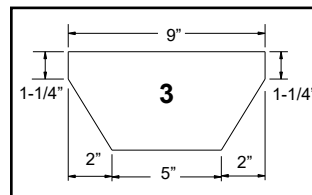

Figure 20.2

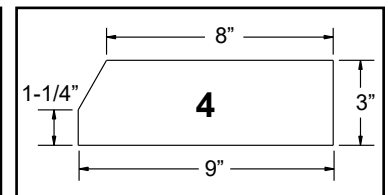

Figure 20.3

Placement	Dimensions	Qty Required
1	9" x 4.5" x 1.25"	12
2	6" x 4.5" x 1.25"	4
3	9" x 4.5" x 1.25" w/Angles	1
4	9" x 3" x 1.25" w/Angle	1

Table 19.1

C. Door Handle Assembly

Do not over tighten lock nut. The door handle needs to move smoothly.

Service Part: SRV8001-002

1. Install washer on door handle shaft.
2. Slide door handle through door.
3. Install second washer(s) as shown in **Figure 20.1**.
4. Install key in groove.
5. Align groove in latch cam with key; slide latch cam over shaft
6. Install locknut but do not over tighten, the handle needs to move smoothly.
7. Install spring handle turning in a counter-clockwise motion to required 2 inch (51mm) clearance location on door handle rod (**Figure 20.1**).

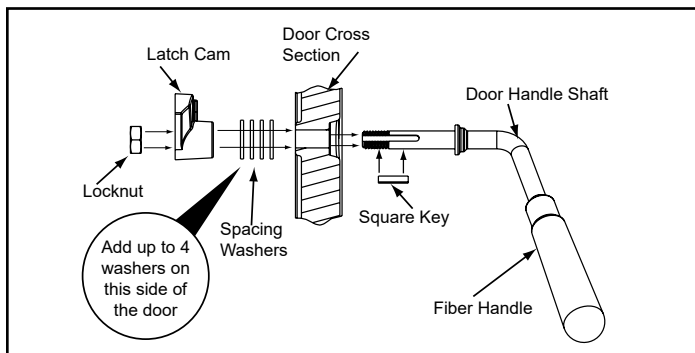

Figure 20.1

D. Baffle Removal

Fiber Blanket Service Part: 832-3390

Baffle Board Service Part: SRV27039-111

1. Remove all ash from the firebox, and extinguish all hot embers before disposal into a metal container.
2. The baffle board has 2 pieces. With the ceramic blanket still in place, slide one baffle piece over the top of other one and pull out top piece through the door opening and then remove bottom baffle piece (**Figure 20.2**).
3. Remove the ceramic blanket.
4. Re-install the baffle pieces one piece at a time. Be sure the baffle boards are even with the front manifold tube and is resting on all tubes (**Figure 20.4 and Figure 20.5**).
5. To re-install the ceramic blanket, it is easier to fold it in half first. Place on top of baffle board, open up and flatten and smooth out the blanket. Re-check the baffle board for correct positioning (**Figure 20.3 and Figure 20.4**).



Figure 20.2 - Baffle

3. Remove the ceramic blanket (**Figure 21.3**).



Figure 20.3 - Ceramic Blanket

4. Re-install the baffle pieces one piece at a time. Be sure the baffle boards are even with the front manifold tube and is resting on all tubes (**Figures 20.4, and Figure 20.5**).

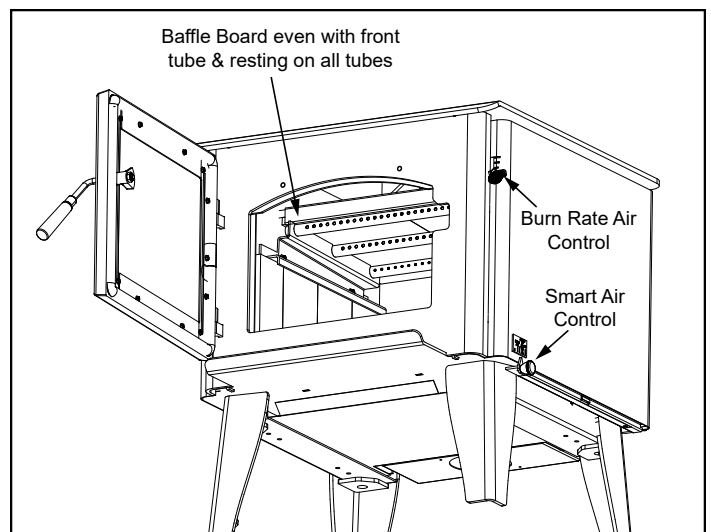

Figure 20.4

5. To re-install the ceramic blanket, it is easier to fold it in half first. Place on top of baffle board, open up and flatten and smooth out the blanket. Re-check the baffle board for correct positioning (**Figure 21.5**).

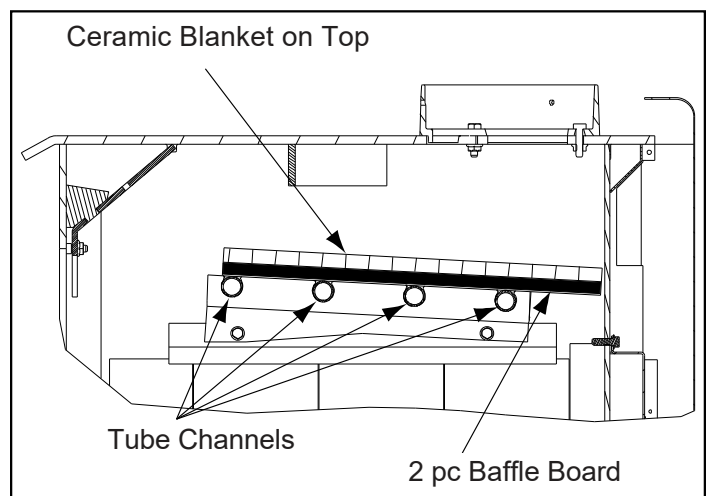

Figure 20.5

F. Tube Channel Assembly

Service Part: SRV7033-023

Removing Tube Channel Assembly

1. Remove the right side shield by removing 2 screws in the back using a Phillips head screw driver.
2. Remove 4 screws from channel access cover and remove cover.
3. Locate 2 channel nuts inside of chamber and remove using a 7/16 socket wrench. Slide out tube channel assembly.

NOTE: Soak the bolts with penetrating oil for at least 15 minutes before trying to remove them.

Replacing Tube Channel Assembly

1. Slide one gasket onto each tube.
2. Slide the tube channel assembly into side of firebox and insert each tube into the corresponding hole in the tube channel rack starting with the back hole first.
3. Make sure tube channel assembly is flush against the side of the appliance and secure with channel nuts.
4. Re-install channel cover and side shield.

NOTE: Service Space

In order to replace the tube channel assembly a clearance of 19 inches (483mm) is required on the right side of appliance in order to remove the tubes with the appliance in place.

If space is not available, the appliance will have to be disconnected from the chimney to proceed with the tube replacement.

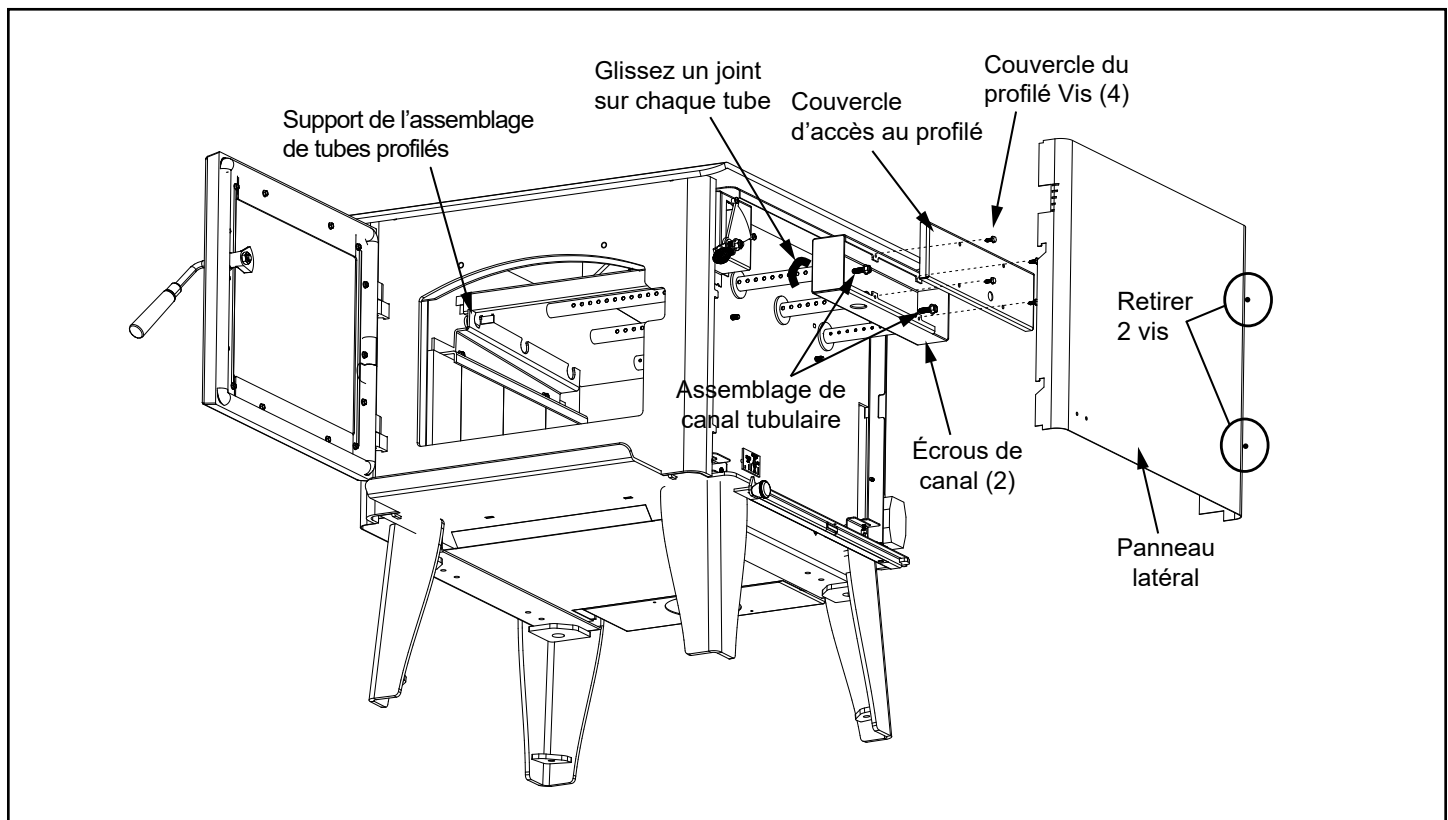

Figure 21.1

B. Service Part List



Service Parts

Forge & Flame Wood Pro 200

FF-WP-200

Beginning Manufacturing Date: Sept 2024
Ending Manufacturing Date: Active

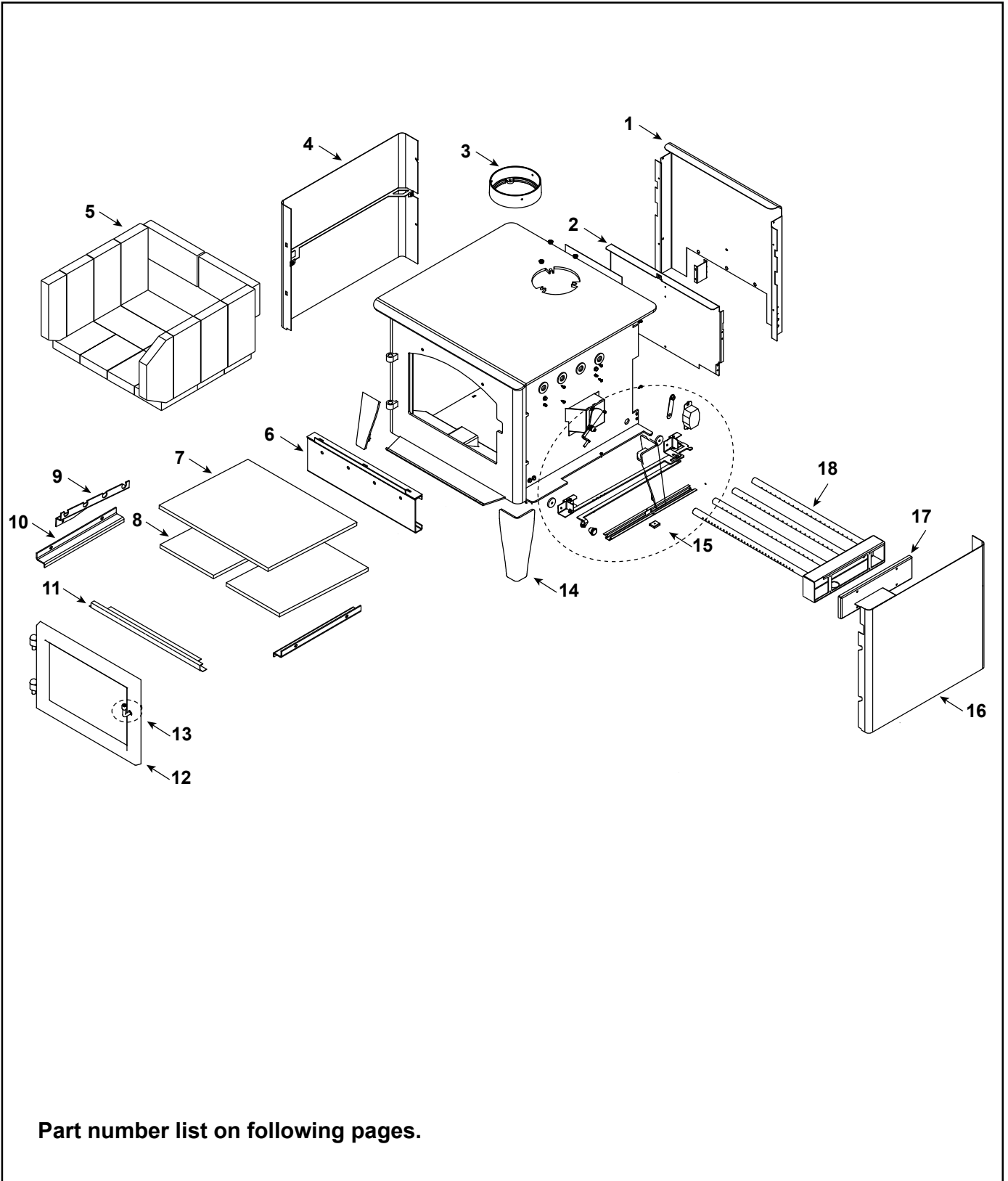

IMPORTANT: THIS IS DATED INFORMATION. When requesting service or replacement parts for your appliance please provide model number and serial number.



Stocked at Depot

ITEM	DESCRIPTION	COMMENTS	PART NUMBER	
1	Air Channel, Convection w/Bracket (Retain Original SN Label)		SRV7033-144	
2	Air Supply Back		SRV7033-134	
3	Flue Collar		SRV7000-302	Y
4	Panel Assembly, Side, Left		SRV7033-019	

#4 Brick Assembly

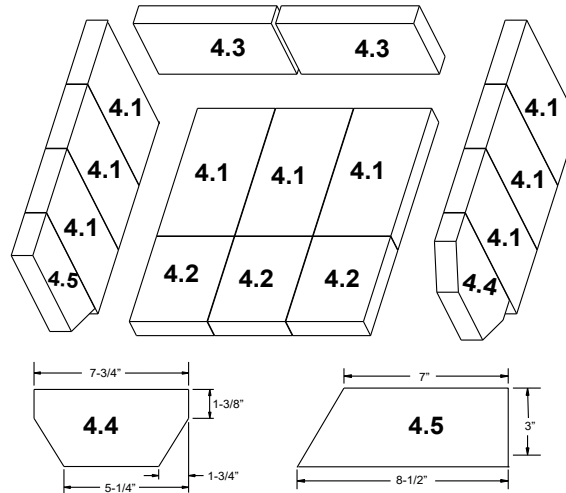

5	Brick Assembly - Complete Set	Pkg of 18	SRV7033-006	
5.1	Brick, 9 x 4-1/2 x 1-1/4" (Qty. 12 Req.)	Pkg of 1	832-0550	
		Pkg of 6	832-3040	
5.2	Brick, 6 x 4-1/2 x 1-1/4"	Qty. 4 Req.	SRV7128-002	
5.3	Brick, 9 x 4-1/2 x 1-1/4" w/angles, see diagram	Qty. 1 Req.	SRV7128-805	
5.4	Brick, 9 x 3 x 1-1/4" w/angle, see diagram	Qty. 1 Req.	SRV7128-617	
6	Rear Channel Assembly		SRV7033-002	Y
7	Ceramic Fiber Blanket, 1/2" Thick (19" W x 13-3/4" H)		832-3390	Y
8	Baffle Board - 9-1/2 in W x 13-3/4 in H	Pkg of 2	SRV7033-209	Y
9	Tube Support Rack		SRV7033-148	
10	Brick Retainer	Qty. 2 Req.	SRV7033-149	

#11 Baffle Protection Channel

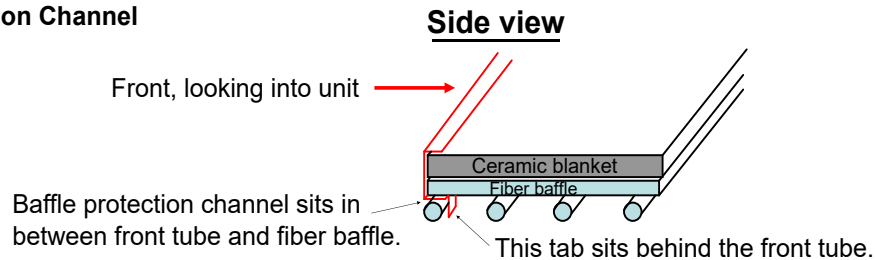

11	Baffle Protection channel		SRV7033-298	
	Mobile Home Brackets		SRV7039-208/4	

Additional service part numbers appear on following page.

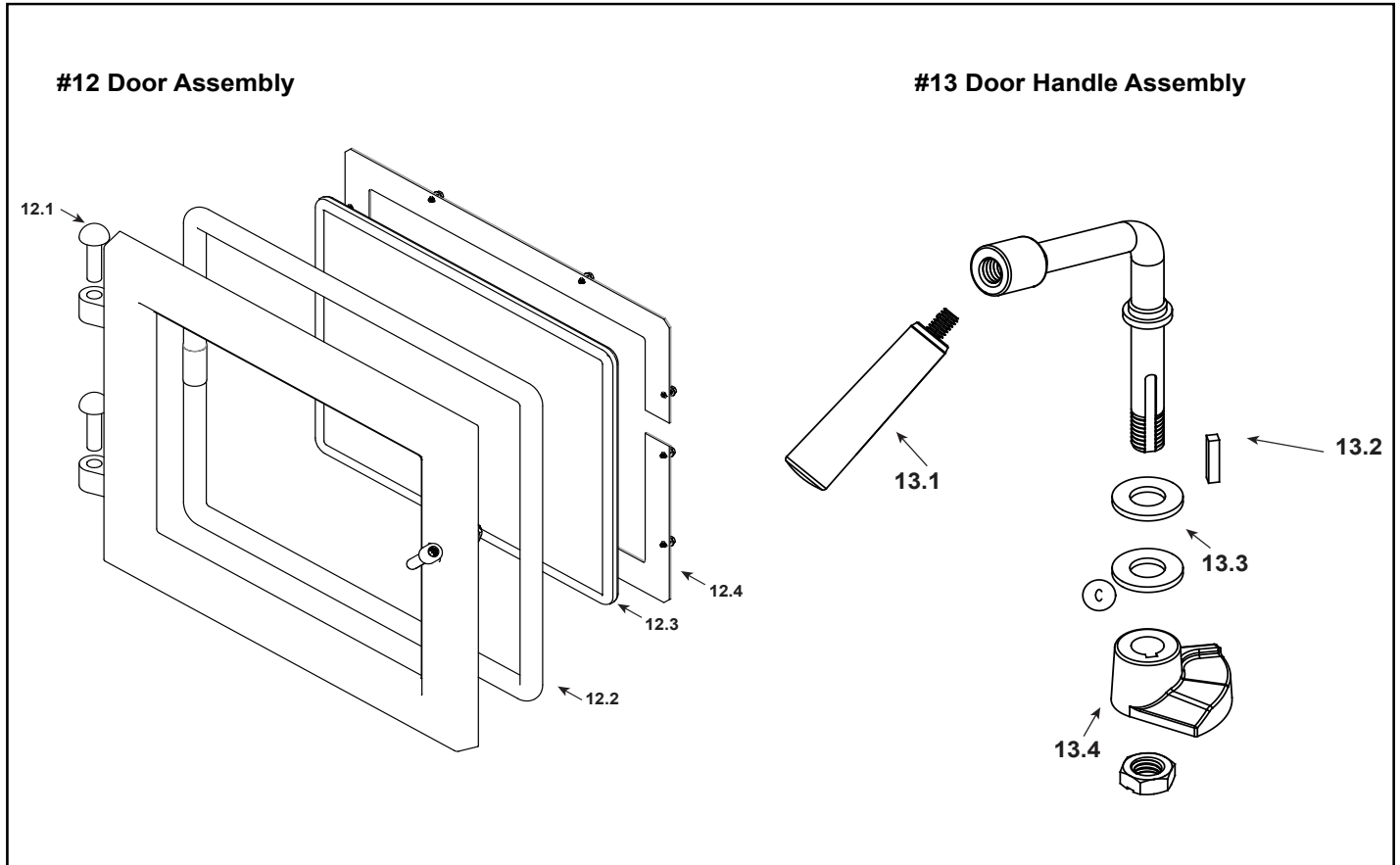

IMPORTANT: THIS IS DATED INFORMATION. When requesting service or replacement parts for your appliance please provide model number and serial number.



Stocked at Depot

ITEM	DESCRIPTION	COMMENTS	PART NUMBER	
12	Door Assembly		SRV7037-061	
12.1	Hinge Pins, 1/2"	Black	7000-606/2	Y
12.2	Rope, Door, 3/4" x 84" - Field cut to Size	7 Ft Length	832-1680	Y
12.3	Door Glass Assembly - 15-1/2" W x 13-3/8" H		SRV7044-027	Y
	Gasket, Glass Tape - Field cut to Size	5 Ft Length	832-0460	Y
12.4	Glass Frame Set		SRV7044-191	
12.5	Screw, Flat Head Philips 8-32 x 1/2	Pkg of 12	220-0490/12	Y
13	Door Handle Assembly		SRV8001-002	
13.1	Door Handle, Formed	Fiber Handle	SRV7000-948	Y
13.2	Key, Cam Latch		SRV430-1151	
13.3	Washer, SAE, 3/8	Pkg of 3	832-0990	Y
13.4	Cam Latch		SRV430-1141	
14	Leg - Painted		SRV7039-060	

Additional service part numbers appear on following page.

#15 Burn Rate Control Assembly

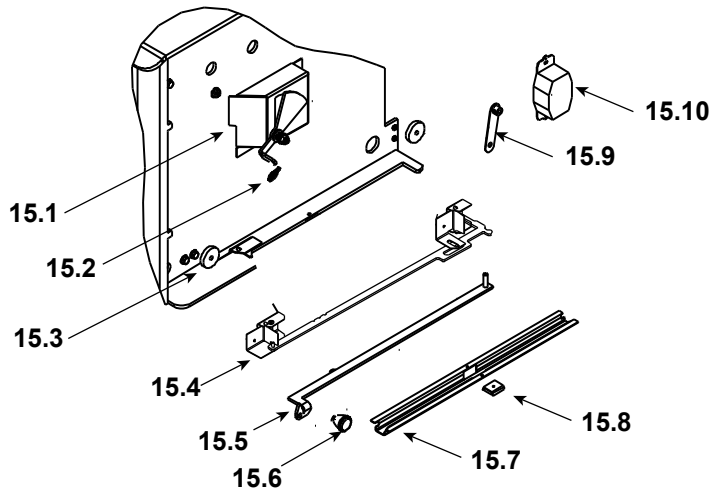

IMPORTANT: THIS IS DATED INFORMATION. When requesting service or replacement parts for your appliance please provide model number and serial number.



Stocked at Depot

ITEM	DESCRIPTION	COMMENTS	PART NUMBER	
15.1	Burn Rate Control Assembly		SRV7033-033	Y
15.2	Spring Handle, 1/4", Black		SRV7000-614	Y
15.3	Door Gasket - Front & Rear Air Timer Doors		7033-282	Y
15.4	Timer Air Control Assembly		SRV7033-052	Y
	Rear Air Door Assembly		SRV7033-024	Y
15.5	Rear Air Control Arm Assembly		SRV7033-035	Y
15.6	Start-Up Control Knob		SRV7000-343	
15.7	Air Control Rod Guide		SRV7033-210	
15.8	Latch, Magnet	For Air Control	SRV229-0631	
15.9	Timer Arm Assembly		SRV7033-034	Y
15.10	Timer (Only) Replacement Assembly		SRV480-1940	Y
16	Panel Assembly, Side, Right		SRV7033-017	
17	Tube Channel Top - Tube Channel Access Cover		SRV7033-237	
18	Tube, Channel Assembly	Manifold Tubes	SRV7033-023	Y
	Gasket, Manifold	Pkg of 4	7038-168/4	Y
	Paint Touch-Up		3-42-19905	
FASTENERS				
	Avk Rivnut Repair Kit - 1/4-20 & 3/8-16 Rivnut Tools		RIVNUT-REPAIR	Y
	Bolt, Hex Head, 1/4-20 x 1	Pkg of 10	25221A/10	Y
	Screw, Sheet Metal #8 x 1/2 S-Grip	Pkg of 40	12460/40	Y



WOOD STOVE INSTALL MANUAL

MODEL: FF-WP-200



woodpro
BY FORGE & FLAME

Find helpful videos
and information on our
Getting Started page

Scan Here





Safety Alert Key:

- **DANGER!** Indicates a hazardous situation which, if not avoided will result in death or serious injury.
- **WARNING!** Indicates a hazardous situation which, if not avoided could result in death or serious injury.
- **CAUTION!** Indicates a hazardous situation which, if not avoided, could result in minor or moderate injury.
- **NOTICE:** Indicates practices which may cause damage to the appliance or to property.

TABLE OF CONTENTS

1 Important Safety Information

A. Appliance Safety Certification	3
B. Appliance Emissions Certification	3
C. BTU & Efficiency Specifications	3
D. Mobile Home Approved	4
E. Glass Specifications	4
F. Non-Combustible Materials	4
G. Combustible Materials	4
H. Sleeping Room	4
I. California - Prop65	4

2 Getting Started

A. Design and Installation Considerations	5
B. Fire Safety	5
C. Negative Pressure	5
D. Tools And Supplies Needed	6
E. Inspection of Appliance and Components	6
F. Removal of Appliance from Shipping Materials	6
G. Install Checklist	7

3 Dimensions and Clearances

A. Appliance Dimensions	8
B. Hearth Protection Requirements	9
C. Clearances to Combustibles	10

4 Chimney Systems

A. Locating Your Appliance & Chimney	11
B. Chimney Termination Requirements	12
C. 2-10-3 Rule	12
D. Chimney Height / Rise and Run	13
E. Venting Components	13
F. Chimney Systems	13
G. Installing Chimney Components	15
H. Proper Draft	15

5 Appliance Set-Up

A. Outside Air Kit Installation	16
---	----

6 Mobile Home Installation 17

7 Reference Materials

A. Service & Maintenance Log	18
--	----

➔ = Contains updated information

1 Important Safety Information

A. Appliance Safety Certification

Model Number:	FF-WP-200
Laboratory:	PFS-TECO
Report Number:	24-338
Type:	Listed Room Appliance, Solid Fuel Type
Standard:	UL 1482 and ULC S627-00 and (UM) 84-HUD, Mobile Home Approved.

B. Appliance Emissions Certification

Model Number:	FF-WP-200
Laboratory:	PFS-TECO
Report Number:	24-338
Standard:	ASTM E2515, ASTM E2780

The WP-200 is Certified to comply with 2020 crib wood particulate emission standards.



This wood appliance needs periodic inspection and repair for proper operation. It is against federal regulations to operate this wood appliance in a manner inconsistent with operating instructions in this manual.

NOTE: This installation must conform with local codes. In the absence of local codes you must comply with **(UM) 84-HUD and NFPA211 in the U.S.A. and CAN/CSA-B365 Installation Codes in Canada.**

This room heater shall not be installed in a factory built fireplace.

C. BTU & Efficiency Specifications

EPA Certification Number:	Number: 86-17
EPA Certified Emissions:	1.9 grams per hour
*LHV Tested Efficiency:	78.3%
**HHV Tested Efficiency:	72.5%
***EPA BTU Output:	13,900 to 29,100 / hr
****Peak BTU/Hour Output:	51,000
Vent Size:	6 inches
Firebox Size:	1.89 cubic feet
Recommended Log Length:	16 inches
Fuel:	Seasoned Cord Wood (20% moisture)
* Weighted average LHV (Low Heating Value) efficiency using Douglas Fir dimensional lumber and data collected during EPA emission tests in accordance with the requirements of CSA B415.1. LHV assumes the moisture is already in a vapor state so there is no loss in energy to vaporize.	
** Weighted average HHV (High Heating Value) efficiency using Douglas Fir dimensional lumber and data collected during EPA emission tests in accordance with the requirements of CSA B415.1. HHV includes the energy required to vaporize the water in the fuel.	
*** A range of BTU outputs calculated using HHV Efficiency and the burn rates from the EPA tests, using Douglas Fir dimensional lumber.	
**** A peak BTU out of the appliance calculated using the maximum first hour burn rate from the High EPA Test and BTU content of seasoned cordwood (8600) times the efficiency.	

D. Mobile Home Approved

- This appliance is approved for mobile home installations; when not installed in a sleeping room and when an outside combustion air inlet is provided.
- The structural integrity of the mobile home floor, ceiling, and walls must be maintained.
- The appliance must be properly grounded to the frame of the mobile home with #8 copper ground wire, and chimney must be listed to **UL103 HT or a listed UL-1777** full length six inch (152mm) diameter liner must be used
- Outside Air Kit, part OAK-ACC must be installed in a mobile home installation. **Note:** Shipping brackets are also used as Mobile Home brackets.

E. Glass Specifications

This appliance is equipped with 5mm ceramic glass. Replace glass only with 5mm ceramic glass.

F. Non-Combustible Materials

Material which will not ignite and burn, composed of any combination of the following:

- Steel
- Plaster
- Brick
- Iron
- Concrete
- Tile
- Glass
- Slate

Materials reported as passing **ASTM E 136, Standard Test Method for Behavior of Metals, in a Vertical Tube Furnace of 750°C.**

G. Combustible Materials

Material made of/or surfaced with any of the following materials:

- Wood
- Compressed Paper
- Plant Fibers
- Plastic
- Plywood/OSB
- Sheet Rock (drywall)

Any material that can ignite and burn: flame proofed or not, plastered or non-plastered.

H. Sleeping Room

When installed in a sleeping room it is recommended that a smoke and/or CO alarm be installed in the bedroom. The size of the room must be at least 50ft³ per 1,000 Btu/hr stove input, if the stove exceeds the room size, outside air must be installed.

I. California - Prop65

WARNING

This product and the fuels used to operate this product (wood), and the products of combustion of such fuels, can expose you to chemicals including carbon black, which is known to the State of California to cause cancer, and carbon monoxide, which is known to the State of California to cause birth defects or other reproductive harm. For more information go to: WWW.P65Warnings.ca.gov

WARNING



Fire Risk

Hearth & Home Technologies disclaims any responsibility for, and the warranty will be voided by, the following actions:

- Installation and use of any damaged appliance.
- Modification of the appliance.
- Installation other than as instructed by Hearth & Home Technologies.
- Installation and/or use of any component part not approved by Hearth & Home Technologies.
- Operating appliance without fully assembling all components.
- Operating appliance without legs attached (if supplied with appliance).
- Do NOT Over fire - If appliance or chimney connector glows, you are over firing.

Any such action that may cause a fire hazard.

Improper installation, adjustment, alteration, service or maintenance can cause injury or property damage.

For assistance or additional information, consult a qualified installer or service agency.

NOTE: Hearth & Home Technologies, manufacturer of this appliance, reserves the right to alter its products, their specifications and/or price without notice.

Hearth & Home Technologies WILL NOT warranty appliances that exhibit evidence of over-firing. Evidence of over-firing includes, but is not limited to:

- Warped air tube
- Deteriorated refractory brick retainers
- Deteriorated baffle and other interior components

2 Getting Started

A. Design and Installation Considerations

Consideration must be given to:

- Safety
- Convenience
- Traffic flow
- Chimney and chimney connector required

It is a good idea to plan your installation on paper, using exact measurements for clearances and floor protection, before actually beginning the installation. If you are not using an existing chimney, place the appliance where there will be a clear passage for a factory-built listed chimney through the ceiling and roof.

We recommend that a qualified building inspector and your insurance company representative review your plans before and after installation.

If this appliance is in an area where children may be near it is recommended that you purchase a decorative barrier to go in front of the appliance. Remember to always keep children away while it is operating and do not let anyone operate this appliance unless they are familiar with these operating instructions.



CAUTION

Check building codes prior to installation.

- Installation MUST comply with local, regional, state and national codes and regulations.
- Consult insurance carrier, local building, fire officials or authorities having jurisdiction about restrictions, installation inspection, and permits.



WARNING

Asphyxiation Risk.



- Do NOT connect this appliance to a chimney flue servicing another appliance.
- Do NOT connect to any air distribution duct or system.

May allow flue gases to enter the house.

NOTICE: Hearth & Home Technologies assumes no responsibility for the improper performance of the appliance system caused by:

- Inadequate draft due to environmental conditions
- Down drafts
- Tight sealing construction of the structure
- Mechanical exhausting devices
- Over drafting caused by excessive chimney heights
- Ideal performance is with height of chimney between 14-16 feet (4.26-4.88m) measured from the base of the appliance.

B. Fire Safety

To provide reasonable fire safety, the following should be given serious consideration:

1. Install at least one smoke detector on each floor of your home to ensure your safety. They should be located away from the heating appliance and close to the sleeping areas. Follow the smoke detector manufacturer's placement and installation instructions, and be sure to maintain regularly.
2. A conveniently located Class A fire extinguisher to contend with small fires resulting from burning embers.
3. A CO detector should be installed in the room with the appliance.
4. A practiced evacuation plan, consisting of at least two escape routes.
5. A plan to deal with a chimney fire as follows:
 - In the event of a chimney fire:
 - Evacuate the house immediately
 - Notify fire department.

C. Negative Pressure



WARNING



Asphyxiation Risk.

- Negative pressure can cause spillage of combustion fumes, soot and carbon monoxide.
- Appliance needs to draft properly for safety.

Negative pressure results from the imbalance of air available for the appliance to operate properly. It can be strongest in lower levels of the house.

Causes include:

- Exhaust fans (kitchen, bath, etc.)
- Range hoods
- Combustion air requirements for furnaces, water appliances and other combustion appliances
- Clothes dryers
- Location of return-air vents to furnace or air conditioning
- Imbalances of the HVAC air handling system
- Upper level air leaks such as:
 - Recessed lighting
 - Attic hatch
 - Duct leaks

To minimize the effects of negative air pressure:

- Install optional outside air kit with the intake facing prevailing winds during the heating season
- Ensure adequate outdoor air for all combustion appliances and exhaust equipment
- Ensure furnace and air conditioning return vents are not located in the immediate vicinity of the appliance
- Avoid installing the appliance near doors, walkways or small isolated spaces
- Recessed lighting should be a “sealed can” design
- Attic hatches weather stripped or sealed
- Attic mounted duct work and air handler joints and seams taped or sealed
- Basement installations should be avoided

**WARNING**

**Fire Risk.**
Hearth & Home Technologies disclaims any responsibility for, and the warranty will be voided by, the following actions:

- Installation and use of any damaged appliance.
- Modification of the appliance.
- Installation other than as instructed by Hearth & Home Technologies.
- Installation and/or use of any component part not approved by Hearth & Home Technologies.
- Operating appliance without fully assembling all components.
- Operating appliance without legs attached (if supplied with appliance).
- Do NOT Over fire - If appliance or chimney connector glows, you are over firing.

Any such action that may cause a fire hazard.

D. Tools And Supplies Needed

Before beginning the installation be sure the following tools and building supplies are available:

- Reciprocating saw
- Framing material
- Pliers
- High temp caulking material
- Hammer
- Gloves
- Phillips screwdriver
- Framing square
- Flat blade screwdriver
- Electric drill and bits
- Plumb line
- Safety glasses
- Level
- Tape measure
- Misc. screws and nails
- 7/16 socket or wrench

1/2-3/4 in. length, #6 or #8 self-drilling screws

E. Inspection of Appliance and Components

- Remove appliance and components from packaging and inspect for damage.
- **Read all the instructions before starting the installation. Follow these instructions carefully during the installation to ensure maximum safety and benefit.**

F. Removal of Appliance from Shipping Materials

1. Remove box and 2x4 structural boards being careful not to damage product.
2. Using 7/16 socket or wrench remove (4) lag bolts located at each leg of the appliance. Using a 9/16 socket or wrench remove (4) nuts installed on each leg leveller. Remove the bracket (**Figure 6.1**).

Note: Retain shipping brackets if being installed into a Mobile Home.

3. Carefully pull appliance off of pallet and put in desired location following Hearth Pad and Clearance to Combustibles.

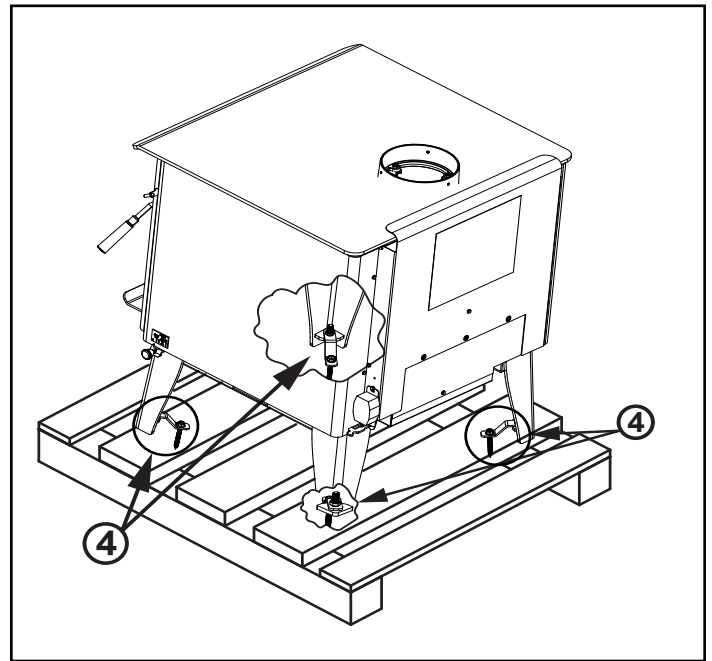



Figure 6.1

**WARNING**

**Fire Risk.**
Inspect appliance and components for damage. Damaged parts may impair safe operation.

- Do NOT install damaged components.
- Do NOT install incomplete components.
- Do NOT install substitute components.

G. Install Checklist

ATTENTION INSTALLER: Follow this Standard Work Checklist

This standard work checklist is to be used by the installer in conjunction with, not instead of, the instructions contained in this installation manual.

Warning! Risk of Fire or Explosion! Failure to install appliance according to these Instructions can lead to a fire or explosion

Appliance Installation

Verified clearances to combustibles.
Appliance is leveled and connector is secured to appliance.
Hearth extension size/height decided.
Floor protection requirements have been met.
If appliance is connected to a masonry chimney, it should be cleaned and inspected by a professional. If installed to a factory built metal chimney, the chimney must be installed according to the manufacturer's instructions and clearances.

YES IF NO, WHY?

<input type="checkbox"/>	_____
<input type="checkbox"/>	_____
<input type="checkbox"/>	_____
<input type="checkbox"/>	_____
<input type="checkbox"/>	_____

Chimney

Chimney configuration complies with diagrams.
Chimney installed, locked and secured in place with proper clearance.
Chimney meets recommended height requirements (14-16 feet).
Roof flashing installed and sealed.
Terminations installed and sealed.

<input type="checkbox"/>	_____
<input type="checkbox"/>	_____
<input type="checkbox"/>	_____
<input type="checkbox"/>	_____
<input type="checkbox"/>	_____

Appliance Clearances

Combustible materials not installed in non-combustible areas.
Verified all clearances meet installation manual requirements.
Mantels and wall projections comply with installation manual requirements.
Protective hearth strips and hearth extension installed per manual requirements.

<input type="checkbox"/>	_____
<input type="checkbox"/>	_____
<input type="checkbox"/>	_____
<input type="checkbox"/>	_____

Appliance Setup

All packaging and protective materials removed.
Firebrick, baffle and ceramic blanket installed correctly.
All labels have been removed from the door.
All packaging materials are removed from inside/under the appliance.
Manual bag and all of its contents are removed from inside/under the appliance and given to the party responsible for use and operation.

<input type="checkbox"/>	_____
<input type="checkbox"/>	_____
<input type="checkbox"/>	_____
<input type="checkbox"/>	_____
<input type="checkbox"/>	_____

WoodPro recommends the following:

- Photographing the installation and copying this checklist for your file.
- That this checklist remain visible at all times on the appliance until the installation is complete.

3 Dimensions and Clearances

A. Appliance Dimensions

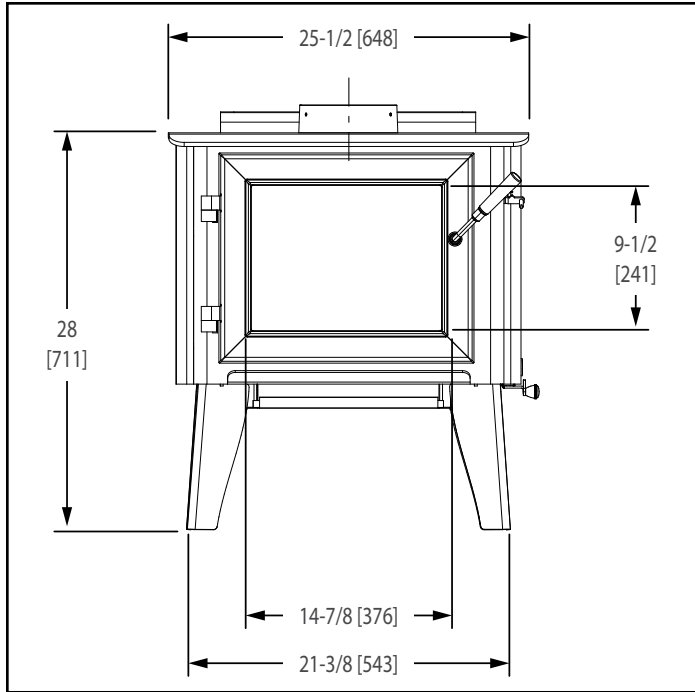

Figure 8.1 - Front View

NOTE: Flue Collar size is 6 inch (152mm) diameter (ID)

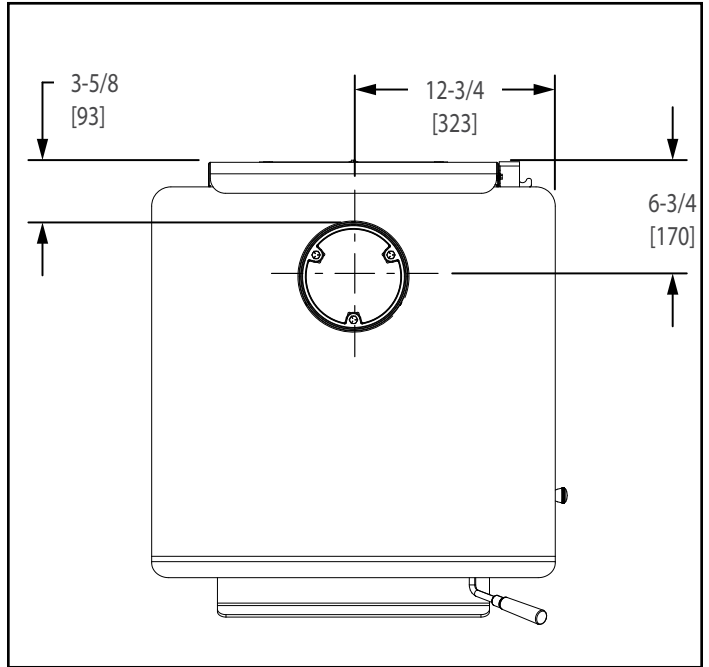

Figure 8.2 - Top View

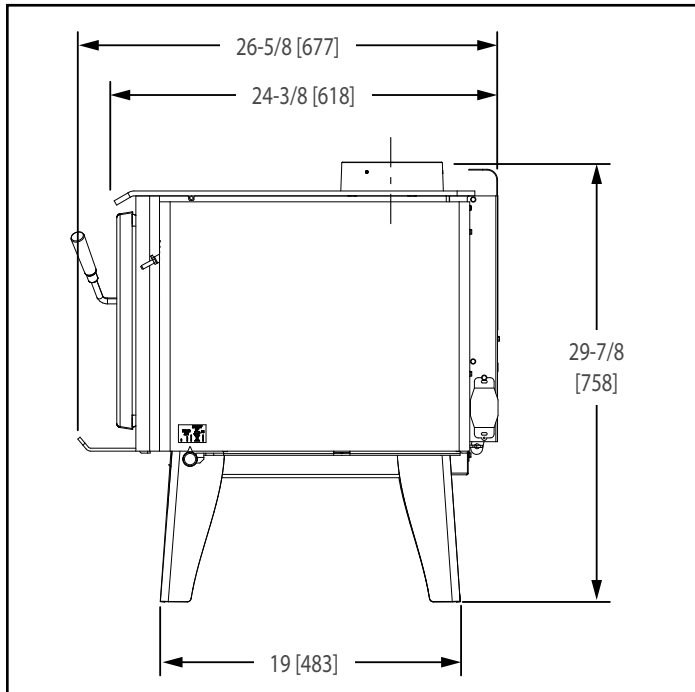

Figure 8.3 - Side View

B. Hearth Protection Requirements

EMBER PROTECTION: Ember protection shall be either a Type 1 floor protector or made of non-combustible material to the requirements below.

Floor protector must be non-combustible material, extending beneath appliance with a minimum of 16 inches (406mm) in front of glass and 8 inches (203mm) to both sides of the fuel loading door. Open the door and measure 8 inches (203mm) from the side edge of the opening in the face of the appliance. ***See Exception.**

In Canada, similar floor protection must be provided 18 inches (457mm) in front and 8 inches (203mm) from the sides and rear of the appliance unless the hearth pad is placed against the wall (**Figure 9.2**). Then the clearance may be reduced using double wall pipe and the **Clearance to Combustibles**.

***Exception:** Non-combustible floor protector must extend beneath the flue pipe when installed with horizontal venting and extend 2 inches (51mm) beyond each side (**Figure 9.2**).

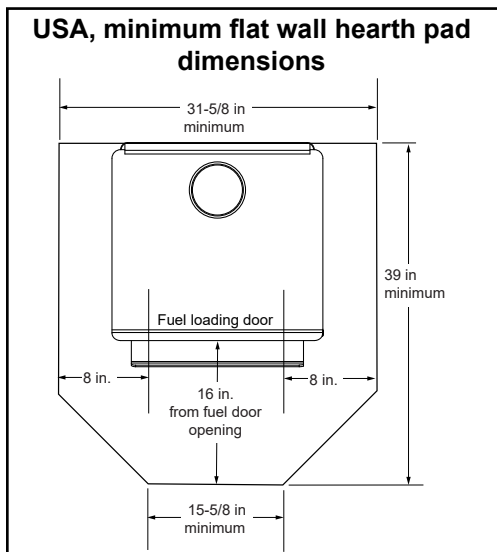

Figure 9.1

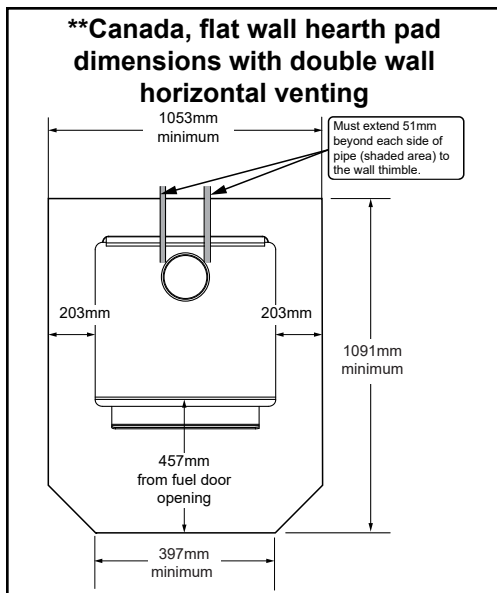



Figure 9.2 - **This dimension will vary depending installation.



CAUTION

Hearth and Home Technologies does not recommend adhesive based vinyl flooring due to thermal expansion. Floating-style flooring (LVP - luxury vinyl plank or LVT – luxury vinyl tile) can be used, but it will reach temperatures up to 110 °F in a room with ambient temperature of 70 °F. Consult flooring specifications to ensure compatibility.

HHT recommends wood stoves and inserts have 57 inches of alternative flooring in front of the stove before using LVP/LVT regardless if they sit flush on the floor or are elevated on a raised hearth.

For all other flooring, continue to follow clearance to combustible requirements in the installation manual.

NOTICE: Clearances that do not meet the minimum guidelines could result in damage or buckling to the vinyl flooring and is done at the installer's or homeowner's risk.



WARNING



Fire Risk.

Hearth pads must be installed exactly as specified. High temperatures or hot embers may ignite concealed combustibles.

Corner hearth pad dimensions with single wall pipe

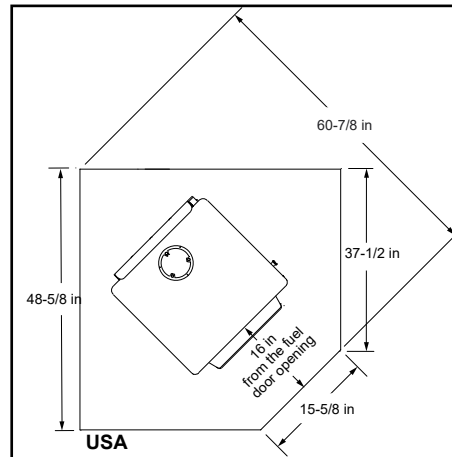

Figure 9.3

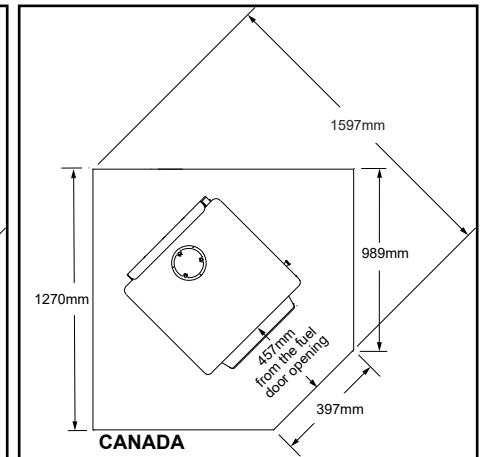

Figure 9.5

Corner hearth pad dimensions with double wall pipe

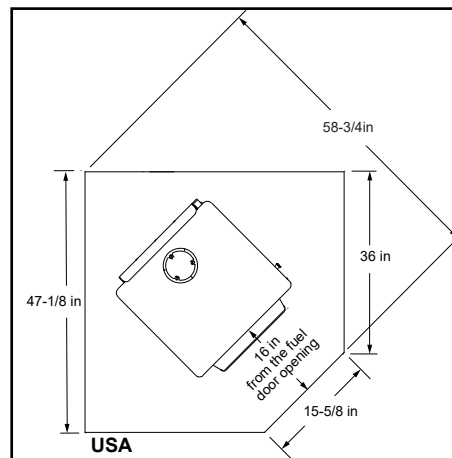

Figure 9.4

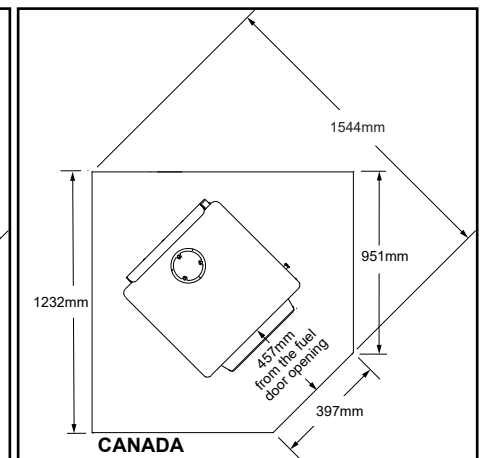

Figure 9.6

C. Clearances to Combustibles

Note: If mantle clearance specifications are not listed or to reduce mantle clearances you can follow NFPA211 regulations to assure safe installation of this product. Please consult with your local building inspector before attempting any clearance reductions.

MINIMUM CLEARANCES TO COMBUSTIBLE MATERIALS IN INCHES (MILLIMETERS)								
NOTE: A, C, AND F DIMENSIONS ARE TO THE CENTER OF THE FLUE COLLAR								
WP-200 WOOD APPLIANCE (2020)								
	A	B	C	D	E	F	G	H
INSTALLATION: FULL VERTICAL								
SINGLE WALL PIPE								
WP-200	18-1/4 (464)	11-3/4 (298)	28-1/2 (724)	16 (406)	8 (203)	20 (208)	48 (1220)	12 (305)
DOUBLE WALL PIPE								
WP-200	13-1/2 (343)	6-1/2 (165)	25 (635)	13 (330)	6-1/2 (165)	18-1/2 (470)	48 (1220)	9 (229)
INSTALLATION: 90 DEGREE ELBOW OFF TOP OF APPLIANCE THROUGH BACKWALL								
SINGLE WALL PIPE								
WP-200	15 (381)	8-1/2 (216)	25 (635)	13 (330)	8 (203)	20 (508)	48 (1220)	12 (305)
DOUBLE WALL PIPE								
WP-200	11 (279)	4-1/2 (114)	20-1/2 (521)	8-1/2 (216)	6-1/2 (165)	18-1/2 (470)	48 (1220)	9 (229)
INSTALLATION: ALCOVE								
DOUBLE WALL PIPE								
WP-200	14-3/4 (375)	8-1/4 (210)	26-1/2 (673)	14-1/2 (368)	N/A	N/A	48 (1220)	N/A
<p>For alcove only: Six inch diameter listed Double wall air insulated connector pipe with UL103 HT listed factory built Class A chimney or masonry chimney. Maximum depth of Alcove shall be no more than 48 inches (1219mm) and the referenced alcove clearances. Canada must comply with CAN/ULC-S269 M87 for the 650° factory built chimney.</p>								
* FOLLOW PIPE MANUFACTURES CLEARANCES AS REQUIRED								

Table 10.1

BACKWALL / SIDEWALL

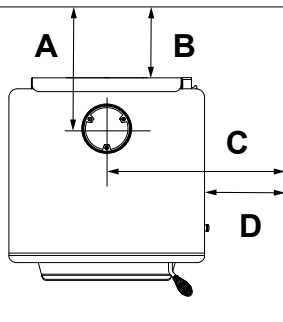

ALCOVE TOP VIEW

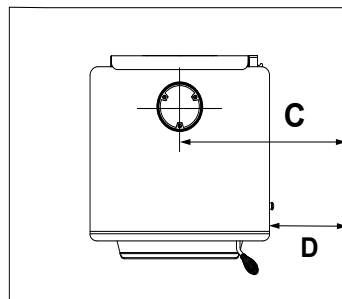

**90° OFF TOP
UP & OUT CEILING
CLEARANCE**

**STOVE TO CEILING
CLEARANCE**

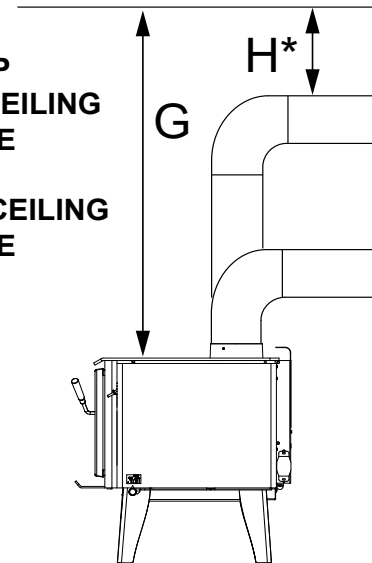

CORNER INSTALLATION

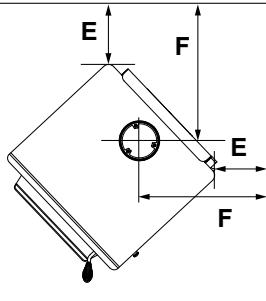

ALCOVE SIDE VIEW

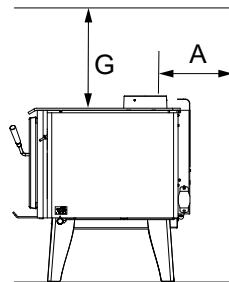

NOTE: Clearances may only be reduced by means approved by the regulatory authority having jurisdiction.

NOTE: Service Space

In order to replace the tube channel assembly a clearance of 19 inches (483mm) is required on the right side of appliance in order to remove the tubes with the appliance in place.

If space is not available, the appliance will have to be disconnected from the chimney to proceed with the tube replacement.



WARNING



Fire Risk.

- Comply with all minimum clearances to combustibles as specified.
- Failure to comply may cause house fire.

4 Chimney Systems

A. Locating Your Appliance & Chimney

Location of the appliance and chimney will affect performance. As shown in **Figure 11.1** the chimney should:

- Install through the warm space enclosed by the building envelope. This helps to produce more draft, especially during lighting and die down of the fire.
- Penetrate the highest part of the roof. This minimizes the affects of wind turbulence and down drafts.

- Consider the appliance location in order to avoid floor and ceiling attic joists and rafters.
- Locate termination cap away from trees, adjacent structures, uneven roof lines and other obstructions.

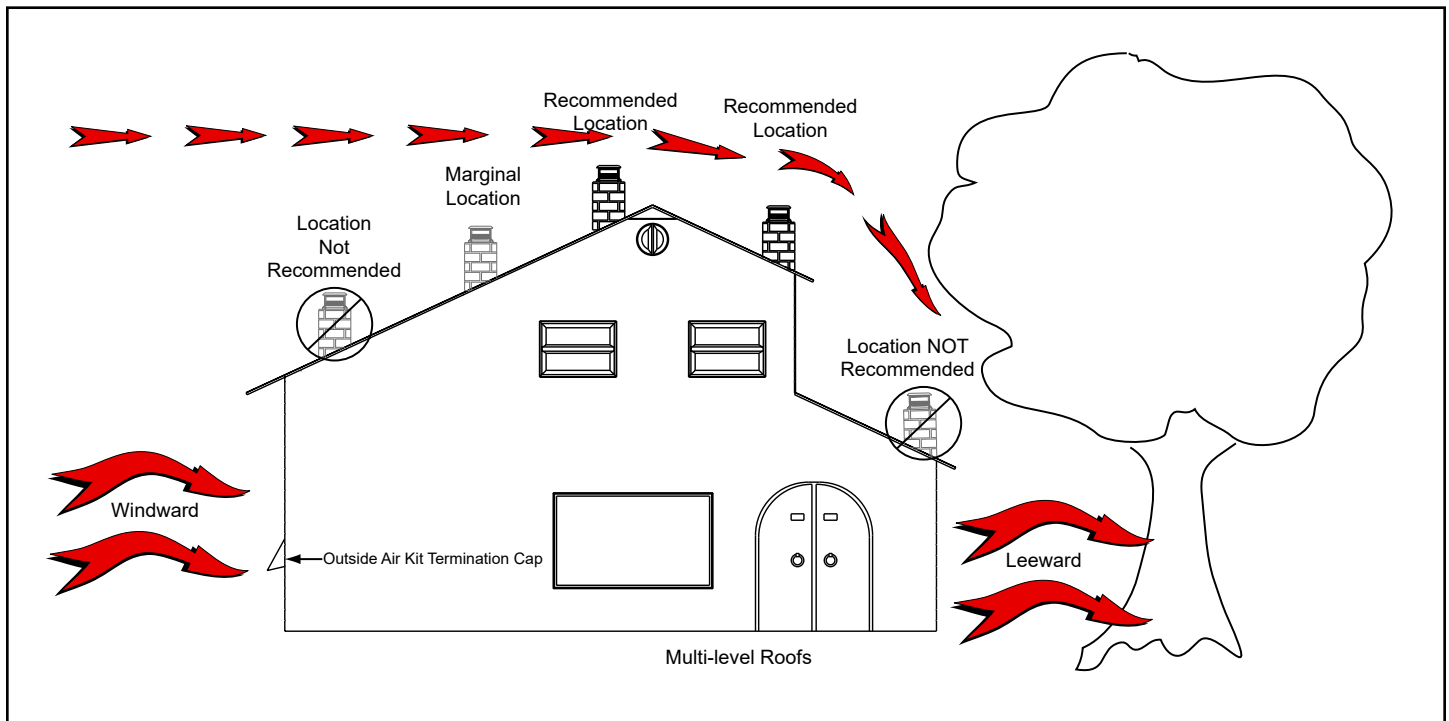

Figure 11.1

B. Chimney Termination Requirements

Follow manufacturer's instructions for clearance, securing flashing and terminating the chimney (**Figure 12.1 and Figure 12.2**).

- Must have an approved and Listed cap
- Must not be located where it will become plugged by snow or other material
- Must terminate at least 3 feet (91cm) above the roof **and** at least 2 feet (61cm) above any portion of the roof within 10 feet (305cm).
- Must be located away from trees or other structures

NOTICE:

- Chimney performance may vary.
- Trees, buildings, roof lines and wind conditions affect performance.
- Chimney height may need adjustment if smoking or overdraft occurs.

NOTICE: Locating the appliance in a basement or in a location of considerable air movement can cause intermittent smoke spillage from appliance. Do not locate appliance near

- Frequently open doors
- Central heat outlets or returns

C. 2-10-3 Rule

These are safety requirements and are not meant to assure proper flue draft.

This appliance is made with a 6 inch (152mm) diameter chimney connector as the flue collar on the appliance.

- Changing the diameter of the chimney can affect draft and cause poor performance.
- It is not recommended to use offsets and elbows at altitudes above 4000 feet above sea level and or when there are other factors that affect flue draft.

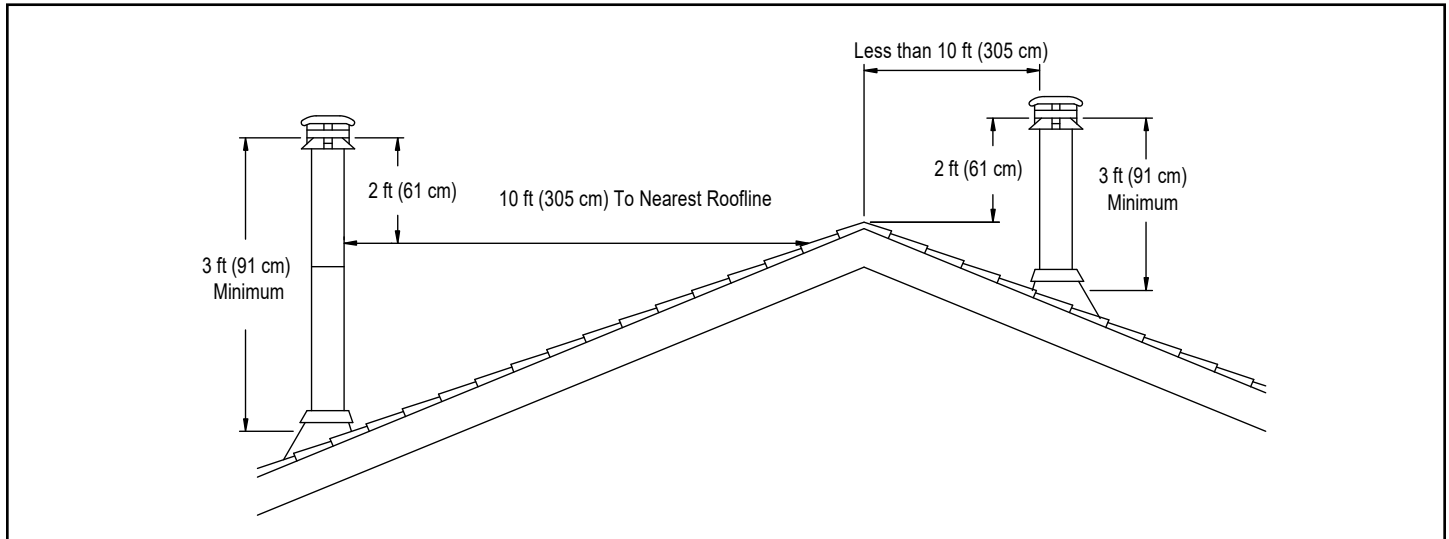

Figure 12.1

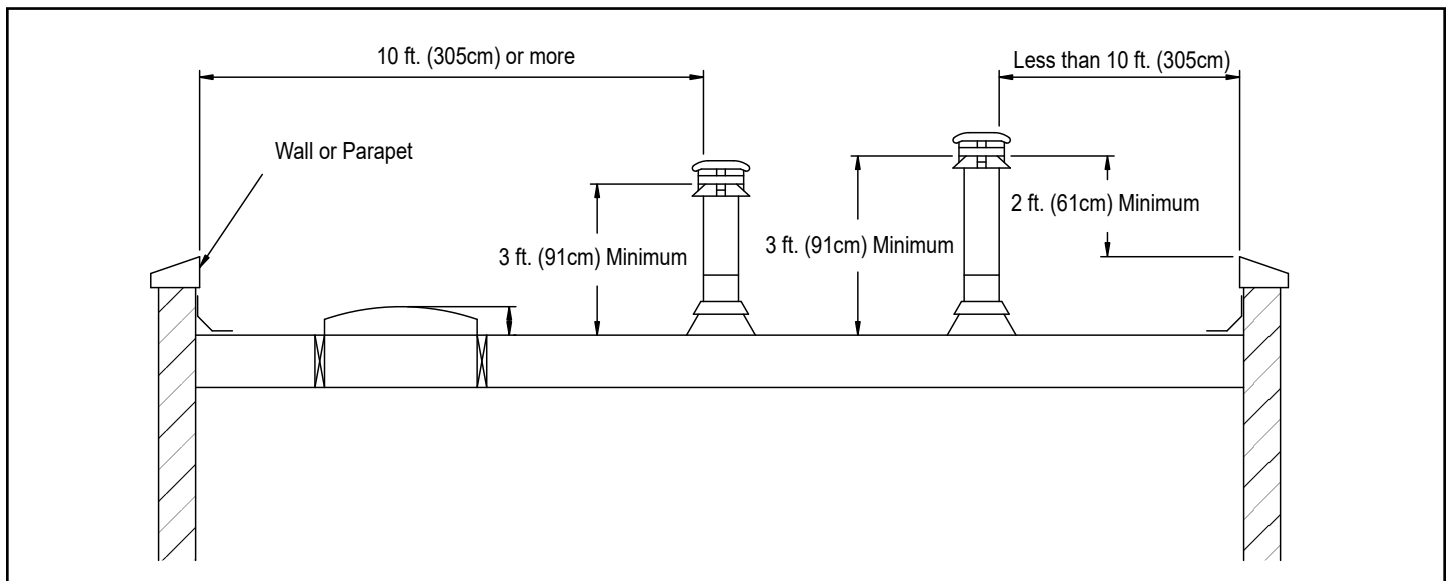





Figure 12.2

D. Chimney Height / Rise and Run

This product was designed for and tested on a 6 inch (152mm) chimney, 14 to 16 feet (420-480cm) high, (includes appliance height) measured from the base of the appliance. The further your stack height or diameter varies from this configuration, the greater the likelihood it may affect performance.

Chimney height may need to be increased by 2 - 3% per each 1000 feet above sea level. It is not recommended to use offsets or elbows at altitudes above 4000 feet above sea level or when there are other factors that affect flue draft.

	WARNING
	<p>Fire Risk. Inspection of Chimney:</p> <ul style="list-style-type: none"> Chimney must be in good condition. Meets minimum standard of NFPA 211 Factory-built chimney must be 6 inch (152mm) UL103 HT.

	WARNING
	<p>Asphyxiation Risk.</p> <ul style="list-style-type: none"> DO NOT CONNECT THIS APPLIANCE TO A CHIMNEY FLUE SERVICING ANOTHER APPLIANCE. DO NOT CONNECT TO ANY AIR DISTRIBUTION DUCT OR SYSTEM. <p>May allow flue gases to enter the house.</p>

	WARNING
<p>Improper installation, adjustment, alteration, service or maintenance can cause injury or property damage. Refer to the owner's information manual provided with this appliance. For assistance or additional information consult a qualified installer or service agency.</p>	

E. Venting Components

Chimney Connector:

It is also known as flue pipe or appliance pipe. The chimney connector joins the appliance to the chimney. It must be a 6 inch (152mm) minimum diameter 24 gauge mild steel black or 26 gauge blued steel, or an approved air-insulated double wall venting pipe.

Thimble:

A manufactured or site-constructed device installed in combustible walls through which the chimney connector passes to the chimney. It is intended to keep the walls from igniting. Site constructed thimbles must meet **NFPA 211 Standards**. Prefabricated must be suitable for use with selected chimney and meet **UL103 Type HT Standards**. Follow instructions provided by the manufacturer for manufactured thimbles for masonry chimney and prefabricated chimneys.

Chimney:

The chimney can be new or existing, masonry or prefabricated and must meet the following minimum requirements and as specified in section 4F **Chimney Systems**.

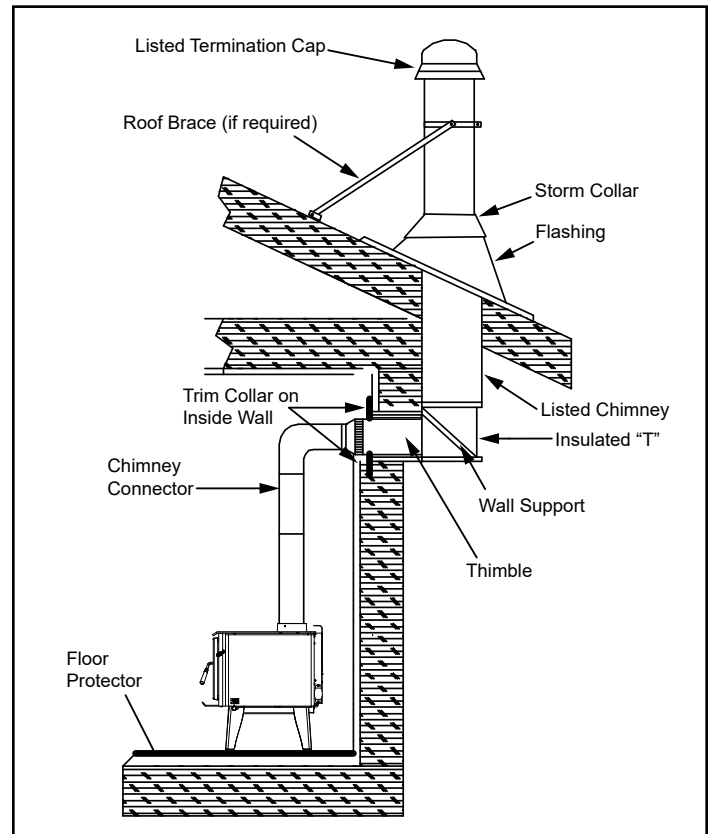

Figure 13.1 - Prefabricated Exterior Chimney

F. Chimney Systems

Prefabricated Metal Chimney

- Must be minimum 6 inch (152mm) diameter (ID) high temperature chimney listed to **UL 103 HT (2100°F) or ULC S629M**.
- Must use components required by the manufacturer for installation.
- Must maintain clearances required by the manufacturer for installation.
- Refer to manufacturers instructions for installation.

NOTE: In Canada when using a factory-built chimney it must be safety listed, **Type UL103 HT (2100°F) CLASS "A" or conforming to CAN/ULC-S629M, STANDARD FOR 650°C FACTORY-BUILT CHIMNEYS.**

Thimble

Site constructed for masonry chimney installation:

Components

A minimum length of 12 inches [305mm] (longer for thicker walls) of solid insulated factory-built chimney length constructed to **UL 103 Type HT 6** inch (152mm) inside diameter. Chimney needs to extend a minimum of 2 inches (51mm) from the interior wall and a minimum of 1 inch (25mm) from the exterior wall.

Wall spacer, trim collar and wall band to fit solid pack chimney selected.

Minimum 8 inch (203mm) diameter clay liner section (if not already present in chimney) and refractory mortar.

When jurisdiction requires install approved chimney liner in masonry chimney.

Air Clearances

- Masonry chimney clearance must meet **NFPA 211** minimum requirement of 2 inches (51mm) to sheet metal supports and combustibles.
- Minimum of 1 inch (25mm) clearance around the chimney connector.
- Top of wall opening is a minimum of 13-1/2 inches (343mm) from ceiling or 4-1/2 inches (114mm) below minimum clearance specified by chimney connector manufacturer. **NFPA 211** minimum vertical clearance of 18 inches (457mm) from chimney connector and ceiling or minimum recommended by chimney connector manufacturer (**Figure 14.2**).

Instructions:

1. Open inside wall at proper height for the chimney connector to entry the masonry chimney (**Figure 14.2**).
2. Entry hole to masonry chimney must be lined with an 8 inch (203mm) minimum diameter clay liner, or equivalent, secured with refractory mortar.
3. Construct a 17 inch x 17 inch (432mm x 432mm) outside dimension frame from 2 x 2 framing lumber to fit into wall opening. Inside opening of frame should be no less than 14 inch x 14 inch (356mm x 356mm) (**Figure 14.2**).
4. Attach the wall spacer to the chimney side of the frame.
5. Nail the frame into the wall opening. The spacer should be on the chimney side.
6. Insert the section of the solid insulated chimney into the outer wall of the masonry chimney.
7. Tightly secure the length of the solid insulated chimney with the wall band to the masonry chimney.
8. Insert a section of chimney connector into the chimney. Make sure it does not protrude past the edge of the clay chimney liner inside the chimney.
9. Seal the end of the chimney connector to the clay liner with refractory mortar.
10. Install trim collar around the solid pack chimney section.

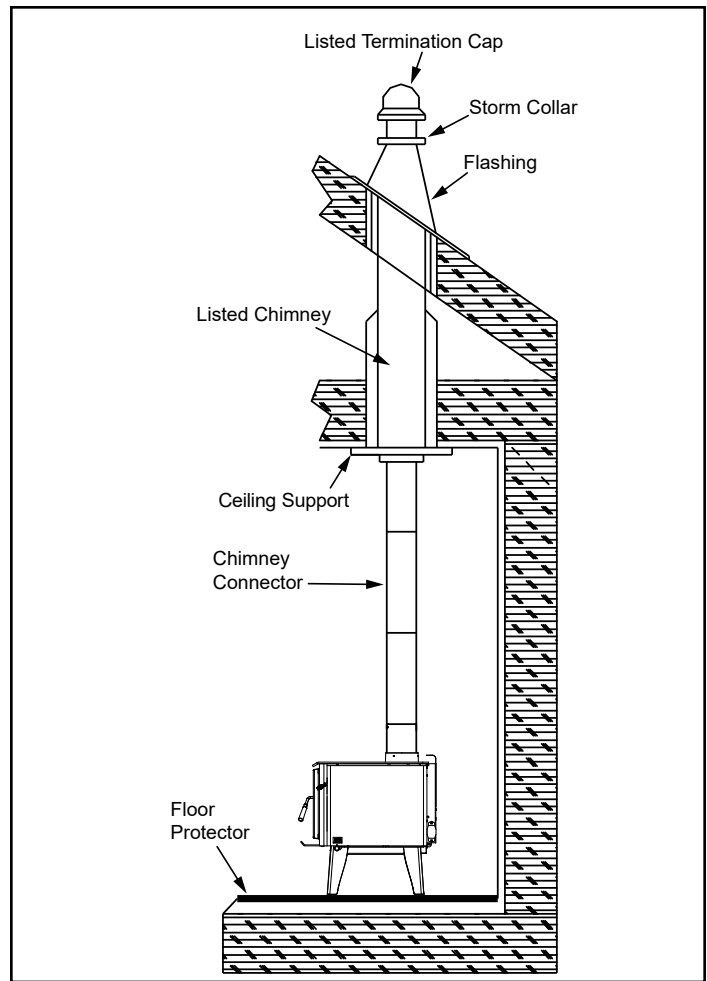

Figure 14.1 - Prefabricated Interior Chimney

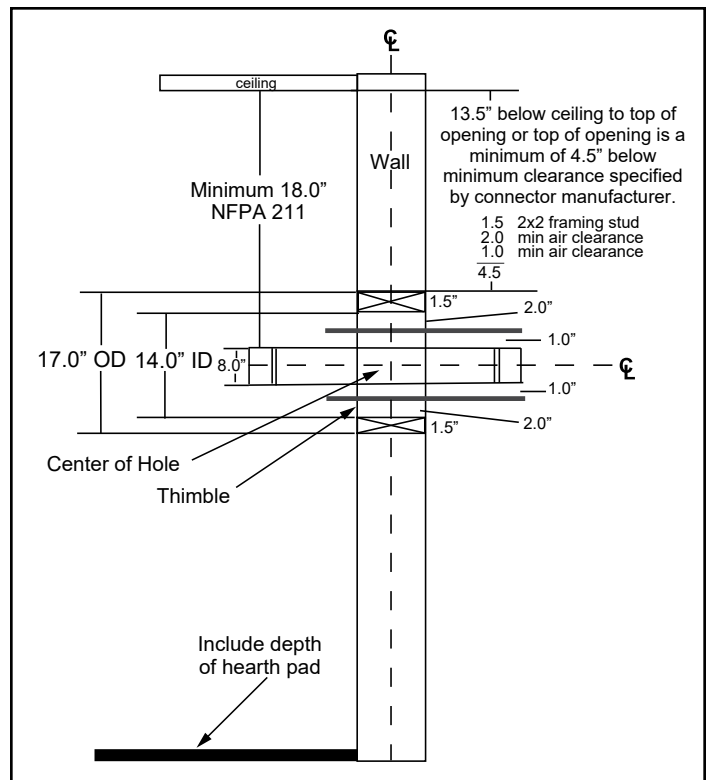

Figure 14.2

Solid Pack Chimney with Metal Supports as a Thimble

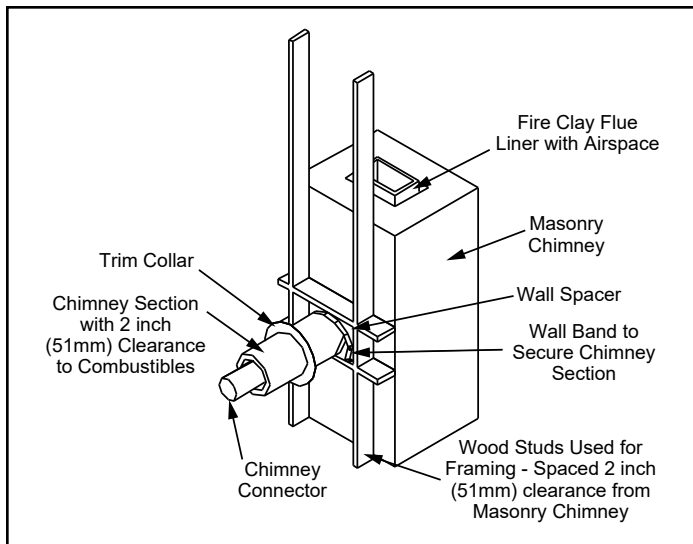

Figure 15.1

WARNING

Fire Risk.
Do NOT pack insulation or other combustibles between spacers.

- ALWAYS maintain specified clearances around venting and spacers.
- Install spacers as specified.

Failure to keep insulation or other material away from vent pipe may cause fire.

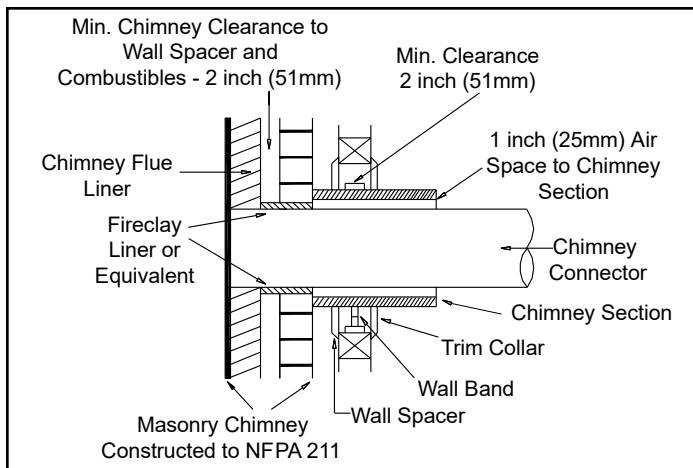

Figure 15.2

G. Installing Chimney Components

Chimney Connector

Single wall connector or appliance pipe.

This must be at least 24 gauge mild steel or 26 gauge blue steel. The sections must be attached to the appliance and to each other with the crimped (male) end pointing toward the appliance. All joints, including the connection at the flue collar, should be secured with 3 sheet metal screws. Make sure to follow the minimum clearances to combustibles. Where passage through the wall, or partition of combustible construction is desired in Canada, the installation shall conform to **CAN/CSA-B365**.

Factory-built listed chimney connector (vented).

A listed connector (vented) must be used when installing this appliance in a mobile home. The listed connectors must conform to each other to ensure a proper fit and seal.

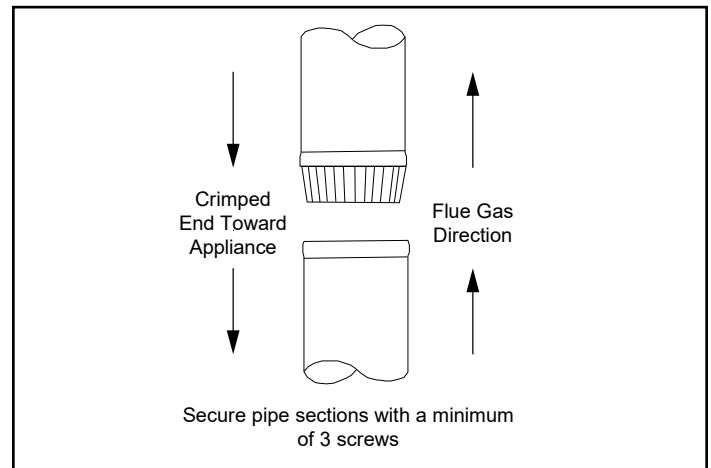

Figure 15.3 - Chimney Connector (Appliance Pipe)

WARNING

Fire Risk.
Follow Chimney Connector Manufacturer's Instructions for Proper Installation.

ONLY use connector:

- Within the room, between appliance and ceiling or wall.

Connector shall NOT pass through:

- Attic or roof space
- Closet or similar concealed space
- Floor or ceiling

Maintain minimum clearances to combustibles

H. Proper Draft

To be sure that your Forge & Flame appliance burns properly, the chimney draft (static pressure) should be approximately -0.10 inches water column (W.C.) during a high burn and -0.04 inches W.C. during a low burn, measured 6 inches (152mm) above the top of the appliance after one hour of operation at each burn setting.

5 Appliance Set-Up

A. Outside Air Kit Installation

A source of air (oxygen) is necessary in order for combustion to take place. Whatever combustion air is consumed by the fire must be replaced. Air is replaced via air leakage around windows and under doors. In homes that have tightly sealed doors and windows, an outside air source is needed. An optional Outside Air Kit is available.

Items Needed for Installation (not supplied)

- 4 inch flex aluminum pipe, or if using alternate material, then it shall be made from durable, non-combustible, heat resistant material up to 350°F. Cut the pipe to the required length for your installation.
 - Phillips head screw driver
 - Silicone sealant
 - Drills and saws necessary for cutting holes through the wall or flooring in your home.
1. Remove all materials from packing box.
 2. Using a #2 Phillips screw driver attach the flex adapter to the appliance using 4 screws (**Figure 16.1**).
 3. **Floor & Rear Installation:**

Cut a 4 inch (102mm) hole in outside wall or floor to accommodate outside air piping. Use 4 inch (102mm) aluminum metal flex or rigid piping to directly connect outside air to appliance intake. Use the supplied termination cap with a rodent screen. Seal between the wall (or floor) and the pipe with silicone to prevent moisture penetration.

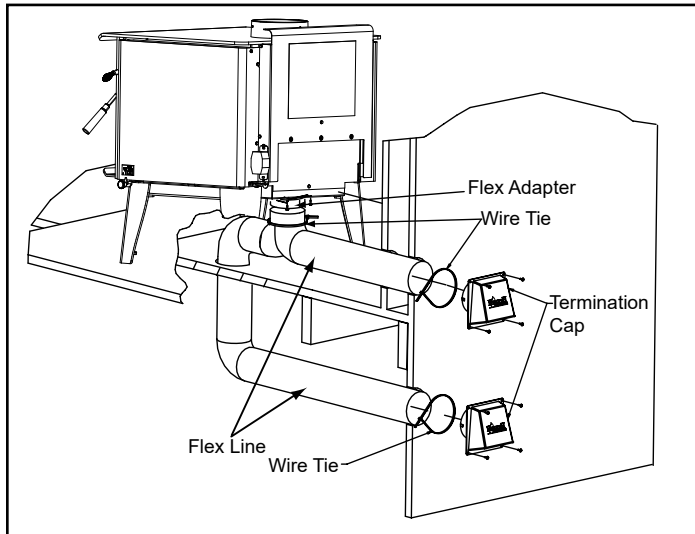

Figure 16.1 - Floor & Rear Installation



WARNING



Asphyxiation Risk.

Outside air inlet must be located to prevent blockage from:

- Leaves
- Snow or ice
- Other debris

Block may cause combustion air starvation
Smoke spillage may set off alarms or irritate sensitive individuals.



WARNING



Asphyxiation Risk.

Length of outside air supply duct shall NOT exceed the length of the vertical height of the exhaust flue.

- Fire will not burn properly
- Smoke spillage occurs when door is opened due to air starvation.

6 Mobile Home Installation

You must use a **Outside Air Kit Part OAK-ACC** for installation in a mobile home.

1. An outside air inlet must be provided for combustion (See section 5A **Outside Air Kit Installation**).
2. Appliance must be secured to the mobile home structure by bolting the pedestal through hearth pad and into floor.
3. Appliance must be grounded with #8 solid copper grounding wire or equivalent and terminated at each end with N.E.C. approved grounding device.
4. Appliance must be installed with an approved **UL103 HT ventilated chimney connector, UL103 HT chimney, and terminal cap with spark arrestor**. Never use a single wall connector (appliance pipe) in a mobile home installation. Use only double-wall connector pipe, Dura-Vent DVL, Selkirk Metalbestos DS or Security DL double-wall connector or any listed double-wall connector pipe.
5. In Canada, this appliance must be connected to a 6 inch (152mm) factory-built chimney conforming to **CAN/ULC-629M, STANDARD FOR FACTORY BUILT CHIMNEYS**.
6. Follow the chimney and chimney connector manufacturer's instructions when installing the flue system for use in a mobile home.
7. Maintain clearance to combustibles.
8. Floor protection requirements must be followed precisely.
9. Use silicone to create an effective vapor barrier at the location where the chimney or other component penetrates to the exterior of the structure.

NOTE: Offsets from the vertical, not exceeding 45°, are allowed per **Section 905(a) of the Uniform Mechanical Code (UMC)**. Offsets greater than 45° are considered horizontal and are also allowed, providing the horizontal run does not exceed 75% of the vertical height of the vent. Construction, clearance and termination must be in compliance with the **UMC Table 9C**. This installation must also comply with **NFPA 211**.

NOTE: Top sections of chimney must be removable to allow maximum clearance of 13.5 feet (411cm) from ground level for transportation purposes.

10. Burn wood only. Other types of fuels may generate poisonous gases (e.g., carbon monoxide).
11. If appliance burns poorly while an exhaust blower is on in home, (i.e., range hood), increase combustion air.
12. Installation shall be in accordance with the **Manufacturers Home & Safety Standard (HUD) CFR 3280, Part 24**.



CAUTION

THE STRUCTURAL INTEGRITY OF THE MOBILE HOME FLOOR, WALL AND CEILING/ROOF MUST BE MAINTAINED

Do NOT cut through:

- Floor joist, wall, studs or ceiling trusses.
- Any supporting material that would affect the structural integrity.



WARNING



Asphyxiation Risk.

NEVER INSTALL IN A SLEEPING ROOM.
Consumes oxygen in the room.



WARNING



Fire Risk.

Do Not use single wall connector pipe anywhere in a mobile home installation.

