



# ASSEMBLY INSTRUCTIONS

Pour le français, voir la page 2. Para el español, ver la página 3.

## 10' x 8' STORAGE SHED

MODEL 60393

### BEFORE ASSEMBLY:

- Assemble on a level surface
- At least 3 adults recommended for setup

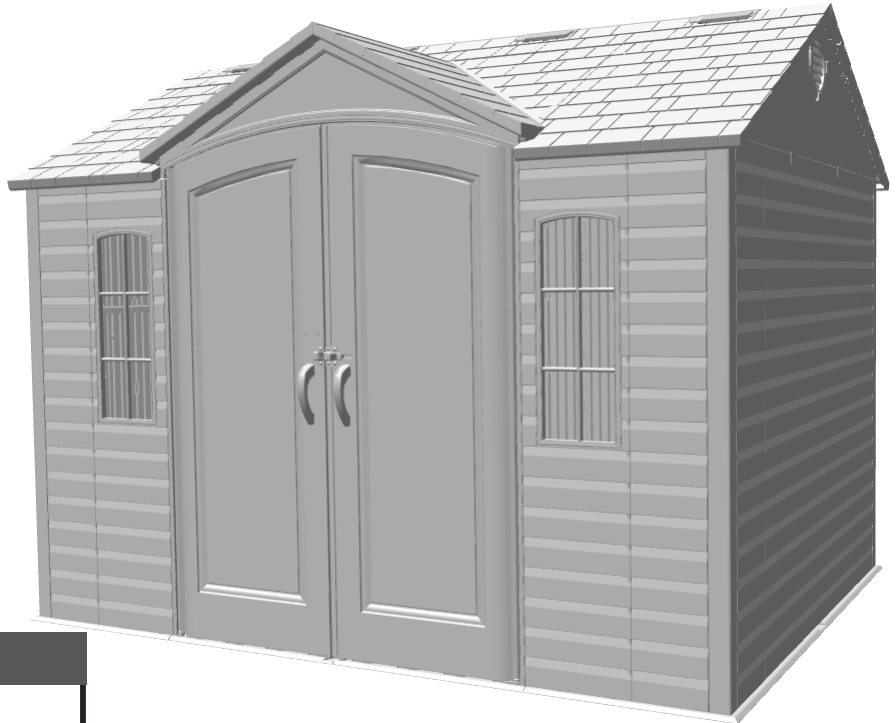

WATCH THE HOW-TO ON YOUTUBE



Scan the code, or visit [go.lifetime.com/60393-fullassembly](http://go.lifetime.com/60393-fullassembly)

YouTube® and the YouTube logo are trademarks of Google, LLC.

## FOR DOMESTIC USE ONLY! IMPORTANT, RETAIN FOR FUTURE REFERENCE: READ CAREFULLY.

### TOOLS REQUIRED

(Not included—unless otherwise indicated\*)

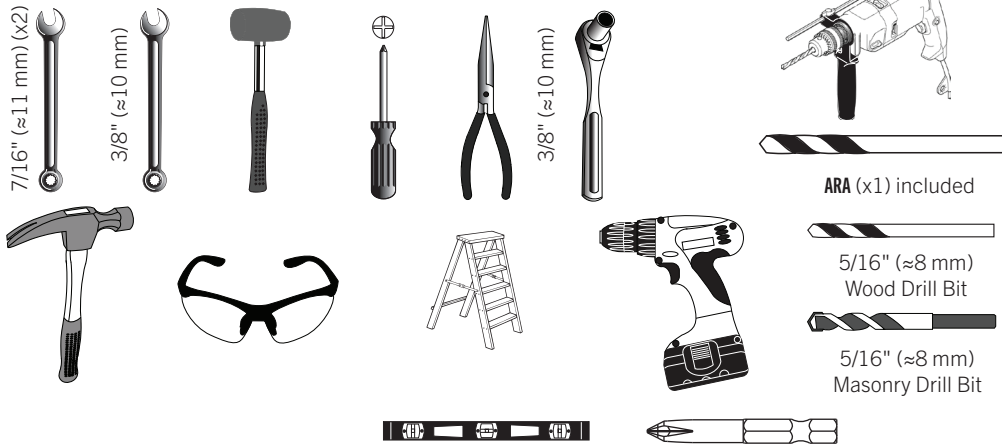

### TABLE OF CONTENTS

Icon legend.....	4
Warnings & notices.....	5
Platform construction.....	6
Truss assembly.....	11
Gable assembly.....	20
Door assembly.....	24
Floor assembly.....	34
Wall assembly.....	39
Parts identifier.....	i-iv
Shelving installation.....	52
Roof assembly.....	58
Door alignment.....	76
Anchoring.....	79
Cleaning & care.....	82
Registration.....	83
Warranty.....	85

### QUESTIONS?

Dial 1-800-225-3865  
(English, French, Spanish)

### CONTACT LIFETIME CUSTOMER SERVICE:

Live Chat: [www.lifetime.com/customerservice](http://www.lifetime.com/customerservice)  
(click on "LIVE CHAT" tab)

For Customer Service in mainland Europe:  
E-mail: [csinternational@lifetime.com](mailto:csinternational@lifetime.com)

Model Number: 60393  
Product ID:



# INSTRUCTIONS D'ASSEMBLAGE

For English, see page 1. Para el español, ver la página 3.

## ABRI EXTÉRIEUR DE 3,1 x 2,4 m

MODÈLE n° 60393

### AVANT L'ASSEMBLAGE :

- Assembler sur une surface de niveau
- Nous recommandons, au moins, 3 adultes pour l'assemblage



REGARDER LA VIDÉO SUR YOUTUBE



Scanner le code, ou visiter [go.lifetime.com/60393-fullassembly](http://go.lifetime.com/60393-fullassembly)

YouTube® et le logotype YouTube sont des marques déposées de Google, LLC.

## POUR L'USAGE DOMESTIQUE SEULEMENT ! IMPORTANT, CONSERVER POUR RÉFÉRENCE : LIRE AVEC PRUDENCE !

### OUTILS REQUIS

(Non inclus — sauf indication contraire\*)

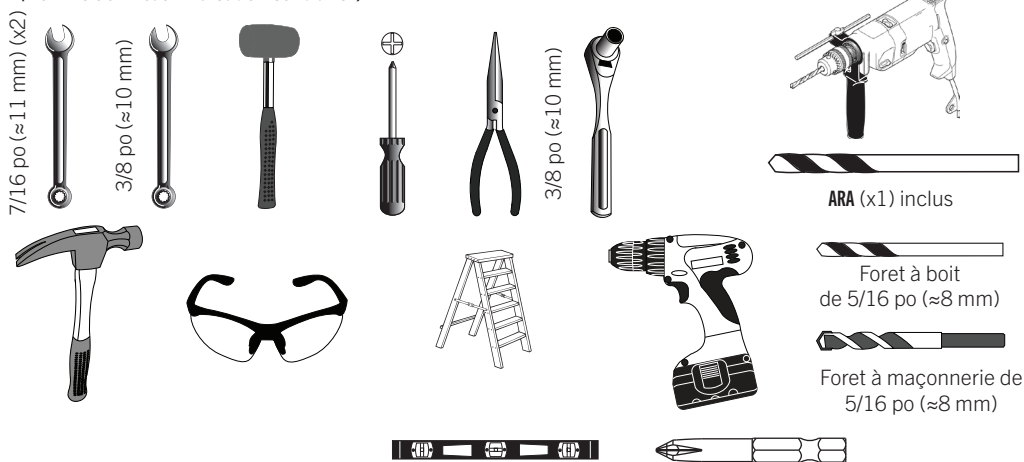

### SOMMAIRE

Légende des icônes.....	4
Avertissements et avis.....	5
Assemblage de la plate-forme.....	6
Assemblage des fermes.....	11
Assemblage des pignons.....	20
Assemblage des portes.....	24
Assemblage du plancher.....	34
Assemblage des murs.....	39
Identificateur des pièces.....	i-iv
Installation du rayonnage.....	52
Assemblage du toit.....	58
Alignement des portes.....	76
L'ancrage de l'abri.....	79
Nettoyage et entretien.....	82
Enregistrement.....	83
Garantie.....	86

### QUESTIONS ?

### CONTACTER LES SERVICES À LA CLIENTÈLE LIFETIME® :

Composer le 1-800-225-3865  
(anglais, français, espagnol)

Entretien en direct: [www.lifetime.com/customerservice](http://www.lifetime.com/customerservice)  
(Cliquez sur la languette « LIVE CHAT »)

Pour les services à la clientèle du continent européen:  
E-mail: [csinternational@lifetime.com](mailto:csinternational@lifetime.com)

N° de modèle : 60393  
Référence du produit :



# INSTRUCCIONES DE ENSAMBLAJE

For English, see page 1. Pour le français, voir la page 2.

## CASETA EXTERIOR DE 2,4 x 3,0 m

MODELO n° 60393

### ANTES DE ENSAMBLAR:

- Ensamblar sobre una superficie nivelada
- Recomendamos, al menos, 3 adultos para el ensamblaje

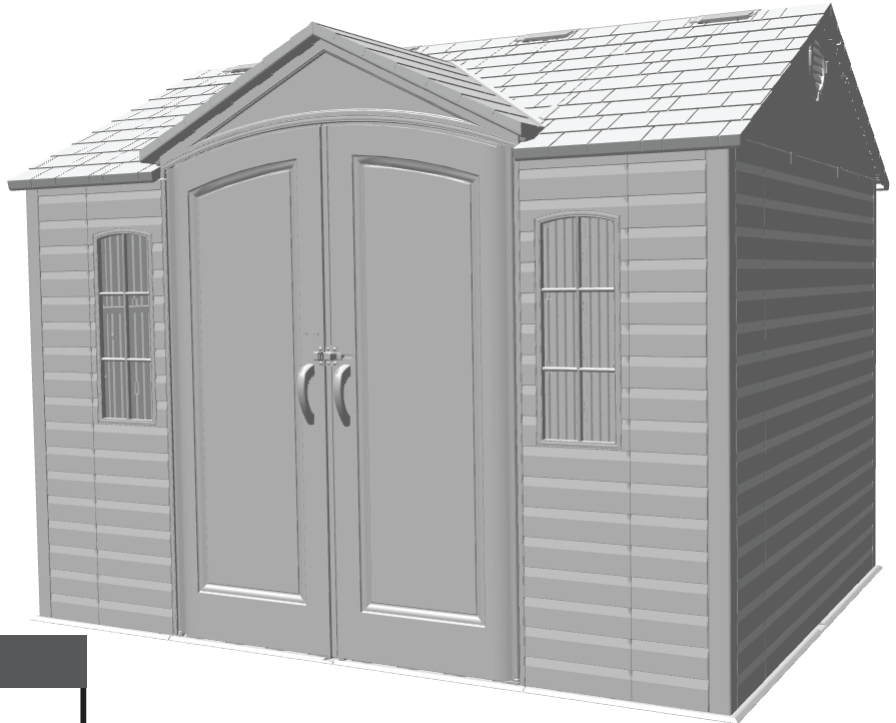

MIRAR EL VIDEO EN YOUTUBE



Escanear el código, o visitar [go.lifetime.com/60393-fullassembly](http://go.lifetime.com/60393-fullassembly)

YouTube® y el logotipo YouTube son marcas registradas de Google, LLC.

### ¡SÓLO PARA USO DOMÉSTICO!

### ¡IMPORTANTE, GUARDAR PARA FUTURA REFERENCIA: LEER CUIDADOSAMENTE!

### INSTRUMENTAL REQUERIDO

(No incluido, salvo indicación contraria\*)

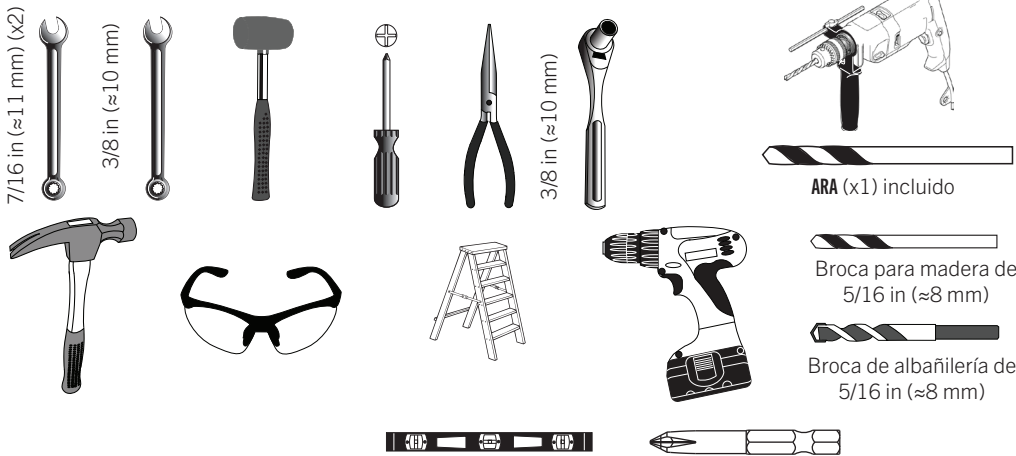

### ÍNDICE

Leyenda de íconos.....	4
Advertencias y avisos.....	5
Ensamblaje de la plataforma.....	6
Ensamblaje de las cerchas.....	11
Ensamblaje de las fachadas.....	20
Ensamblaje de las puertas.....	24
Ensamblaje del piso.....	34
Ensamblaje de los muros.....	39
Identificador de piezas.....	i-iv
Instalación de la estantería.....	52
Ensamblaje del tejado.....	58
Alineación de las puertas.....	76
Anclaje de la caseta.....	79
Limpieza y cuidado.....	82
Registro.....	83
Garantía.....	87

### ¿PREGUNTAS?

### PONERSE EN CONTACTO CON LOS SERVICIOS DE CLIENTES LIFETIME®:

Marcar al **1-800-225-3865**  
(inglés, francés, español)

Chat en vivo: [www.lifetime.com/customerservice](http://www.lifetime.com/customerservice)  
(clicar en la lengüeta «LIVE CHAT»)

Para el servicio a clientes en el continente europeo:  
Correo electrónico: [csinternational@lifetime.com](mailto:csinternational@lifetime.com)

Número de modelo: 60393  
ID del producto:



## ICON LEGEND / LÉGENDE DES ICÔNES / LEYENDA DE ÍCONOS



- Indicates special heed should be taken when reading.
- Indique qu'une attention spéciale doit être portée à la lecture.
- Indica que uno debe prestar atención al leer.



- Indicates the parts (or no parts) required for a section.
- Indique les pièces (ou aucune pièce) à utiliser pour une section.
- Indica las piezas (o ninguna pieza) que se usarán en una sección.



- Indicates the hardware (no new hardware) required for a specific page or section.
- Indique la quincaillerie (ou aucune nouvelle quincaillerie) n'est requis pour une page précise.
- Indica el herraje (que no se necesita nuevo herraje) para una página específica.



- Indicates the tools (or no tools) to be used for a section.
- Indique les outils (ou aucun outil) à utiliser pour une section.
- Indica las herramientas (o ninguna herramienta) que se utilizarán para una sección.



- Indicates to use/not use an electric drill for a specific step.
- Indique quand utiliser une/que ne pas utiliser de perceuse électrique pour une étape précise.
- Indica la utilización de/que no utilizar un taladro eléctrico para un paso específico.



- Indicates the number of adults required to perform a specific step, e.g., 2, 3, 4, etc. **You may be able to do certain steps by yourself but, for safety reasons, it's best to have two or more adults. And...it's always easier with one or two helpers.**
- Indique le nombre d'adultes requis pour effectuer une étape spécifique, p. ex., 2, 3, 4, etc. **Il est possible de réaliser certaines étapes seul mais, pour des raisons de sécurité, il est préférable d'être au moins deux adultes. Et... c'est toujours plus facile avec un assistant ou deux.**
- Indica el número de adultos requeridos para realizar un paso específico, p.ej., 2, 3, 4, etc. **Es posible realizar unos pasos solo mas, por razones de seguridad, es mejor tener dos adultos o más. Y... siempre es más fácil con un ayudante o dos.**



- Indicates to repeat a step or an action.
- Indique de répéter une étape ou une action.
- Indica repetir un paso o una acción.

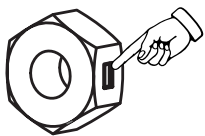

- Indicates the use of a centerlock nut. A nut with this marking will require some effort to tighten. This hardware was designed with this feature in order to prevent loosening later.
- Cette image indique l'usage d'un écrou de blocage central. Un écrou avec ce marquage requerra plus d'effort pour le serrer. Cet écrou a été conçu avec cette fonction afin d'empêcher son desserrage plus tard.
- Indica el uso de una tuerca de bloque central. Una tuerca con esta marca requerirá un poco de esfuerzo para apretarlo. Esta tuerca fue diseñada con esta característica con el fin de evitar su aflojamiento más tarde.

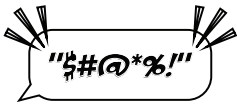

- Indicates a specific step is harder to perform.
- Indique qu'une étape spécifique est plus difficile à exécuter.
- Indica que un paso específico es más difícil de realizar.



- Indicates that one should only hand-tighten the hardware until instructed otherwise.
- Indique qu'il ne faut serrer la quincaillerie qu'à la main jusqu'à ce que l'on reçoive des instructions contraires.
- Indica que sólo se debe apretar a mano el herraje hasta que indique lo contrario.





## WARNINGS & NOTICES / AVERTISSEMENTS ET AVIS / ADVERTENCIAS Y AVISOS



### English:

- **Failure to follow these warnings may result in serious injury or property damage and will void warranty.**
- To ensure safety, do not attempt to assemble this product without following the instructions carefully.
- Consult all local building codes to verify if the shed requires a building permit.
- Verify the platform foundation is completely level before assembling the shed.
- Be aware that plastic pieces can be damaged by overtightening the screws. To avoid damage, we strongly recommend the use of a drill with a low torque setting. A #2 Phillips screwdriver may also be used.
- Three capable adults are required for assembly.
- All who participate in the assembly process should wear safety glasses throughout the assembly.
- If using a ladder during assembly, use extreme caution.
-  In heavy snowfall areas, we recommend removing snow from the roof. Remove the snow from the roof when the depth of snow equals the length of your hand.
- Do not use or store hot objects near the product.
- Proper and complete assembly are essential to reduce the risk of accident or injury.
- When drilling through metal, beware of burrs, shavings and other sharp edges.
- During and after assembly, do not slide or lift the shed by pushing up on the roof. Move the shed by pushing on the corner panels only.
- Failure to anchor the shed may result in property damage and/or personal injury. The last section, *Shed Anchoring*, in this manual shows the hardware you will need to complete the anchoring. You can find the hardware at your local hardware store.
- **Most injuries are caused by misuse and/or not following instructions. Use caution when using this product.**

### Français :

- **Ne pas suivre ces avertissements peut entraîner des blessures graves ou des dommages à la propriété et annulera la garantie.**
- Afin d'assurer la sécurité, ne pas tenter d'assembler ce produit sans suivre attentivement les instructions.
- Consulter tous les codes du bâtiment afin de vérifier si l'abri nécessite un permis de construire.
- Vérifier que la fondation de la plate-forme est complètement à niveau avant l'assemblage de l'abri.
- Ne pas oublier que les pièces de plastique peuvent être endommagées en serrant trop les vis. Afin d'éviter les dommages, nous recommandons fortement l'utilisation d'une perceuse à faible couple. Un tournevis cruciforme n° 2 peut aussi être utilisé.
- Trois adultes en bonne condition physique sont nécessaires pour l'assemblage.
- Tout ceux qui participent au processus de l'assemblage doivent porter des lunettes de sécurité tout au long de l'assemblage.
- Si une échelle est utilisée pour l'assemblage, il faut être extrêmement prudent.
- Dans les zones de fortes tombées de neige, il est recommandé de dégager le toit. Enlever la neige du toit quand la profondeur est égale à la longueur de la main.
- Ne pas utiliser ou entreposer des objets très chauds près de ce produit.
-  Un bon assemblage complet est nécessaire pour réduire le risque d'accident ou de blessure.
-  En perçant le métal, faire attention aux bavures, copeaux et autre bords aiguisés.
- Pendant et après l'assemblage, ne pas faire glisser ou soulever l'abri en poussant le toit vers le haut. Déplacer l'abri en poussant les panneaux muraux angulaires seulement.
- Si vous n'ancrez pas votre abri, des dommages à la propriété et/ou des blessures peuvent en résulter. La dernière section, *Ancrage de l'abri*, de ce manuel indique les matériaux nécessaires pour l'ancrage. Les matériaux se trouvent dans la quincaillerie locale.
- **La majorité des blessures sont causées par une mauvaise utilisation et/ou le non suivi des instructions. Être prudent en utilisant ce produit.**

### Español:

- **No seguir estas advertencias puede resultar en lesiones graves o daños a la propiedad y anulará la garantía.**
- A fin de garantizar la seguridad, no intentar ensamblar este producto sin seguir cuidadosamente las instrucciones.
- Consultar todos los códigos de construcción locales para verificar si el cobertizo requiere un permiso de construcción.
- Verificar que el concreto de la plataforma esté nivelado completamente antes de ensamblar el cobertizo.
- Tener en cuenta que las piezas de plástico pueden dañarse si los tornillos se aprietan de más. A fin de evitar daños, lo exhortamos a que use un taladro con función de torque bajo. También puede usarse un desatornillador Phillips no. 2.
- Se necesitan tres adultos para el ensamble.
- Todos los que participan en el proceso de ensamble debe usar anteojos de seguridad durante todo el ensamble.
- Si se usa una escalera durante el ensamblado, es preciso tener cuidado.
- En áreas de nevadas fuertes, recomendamos retirar la nieve del techo. Quitar la nieve del tejado cuando la profundidad de ella es igual a la longitud de la mano.
- No usar ni guardar objetos calientes cerca del producto.
-  El ensamblaje correcto y completo son esenciales para reducir el riesgo de accidente o lesión.
-  Al perforar metal, tenga cuidado las rebabas, virutas y otros bordes afilados.
- Durante y después del ensamblaje, no deslizar ni levantar el cobertizo para empujar en el tejado. Mover el cobertizo para empujar los paneles murales angulares solamente.
- No anclar el cobertizo puede resultar en daños a la propiedad y/o en lesiones personales. La última sección, *Anclaje de el cobertizo*, en este manual muestra el herraje necesaria para terminar el anclaje. Se encuentra el herraje en la ferretería local.
- **La mayoría de las lesiones suceden a causa del mal uso y/o por no seguir las instrucciones. Tener precaución al usar este producto.**



• You must provide a platform on which to assemble your shed. Proper building permit documentation may be required in your neighborhood. Consult all local building codes prior to assembling the shed. Before beginning assembly, you must pour or construct a platform. There are two types:

- Concrete
- Wood Frame

Select the type, but know the surface must be leveled before installation. If the surface is not properly leveled, the shed will not assemble correctly. Proper surface leveling will save you time in the long run, so please do not ignore this step. **We recommend a Concrete platform. It will be the most durable and long-lasting choice. The platform you choose must be built above ground in order to avoid water pooling inside the shed. All lumber must be rated for outdoor use!**



• Il faut construire une plate-forme sur laquelle vous devez assembler votre abri. Il est possible que votre quartier exige une documentation visant les permis de construire. Consultez tous les codes du bâtiment locaux, ainsi que les décrets des villes et comtés, pour vérifier que la construction de l'abri extérieur n'exige pas un permis de construire. Avant de commencer le montage, il faut couler ou construire une plate-forme. Il y a deux styles :

- Béton
- Cadre à bois

Sélectionnez le style, mais sachez que la surface d'installation doit être de niveau. Si la surface n'est pas correctement de niveau, l'assemblage de l'abri ne se fera pas correctement. Vous gagnerez du temps sur le long terme grâce à une surface bien de niveau, ne négligez donc pas cette étape. **Nous recommandons une plate-forme en Béton. Ce choix sera le plus durable. La plate-forme que vous choisissez doit être construite au-dessus du sol afin d'éviter l'accumulation d'eau à l'intérieur de l'abri. Tous le bois d'oeuvre doit être approuvé pour l'usage à l'extérieur !**



• Es preciso construir una plataforma sobre la cual usted debe ensamblar su caseta. Puede suceder que en su vecindario se requiera la documentación apropiada de un permiso de construcción. Consulte todos los códigos locales de construcción y los reglamentos de la ciudad y el municipio para asegurarse de que la construcción de la caseta no requiere un permiso de construcción. Antes de comenzar el ensamble, es necesario verter o construir una plataforma. Hay dos clases:

- Concreto
- Armazón de madera

Seleccione la clase, mas sepa que la superficie debe estar nivelada antes de comenzar el ensamble. Si la superficie no está nivelada de manera adecuada, la caseta no podrá ensamblarse correctamente. La nivelación de la superficie le ahorrará tiempo de trabajo, por lo tanto, le pedimos que no ignore este paso. **Recomendamos una plataforma hecho de concreto. Será la elección más perdurable. La plataforma debe ser construida arriba del suelo para evitar el aflujo de agua dentro de la caseta. ¡Toda la madera debe estar clasificada para el uso externo!**



## SECTION 1 (CONTINUED) / SECTION 1 (SUITE) / SECCIÓN 1 (CONTINUACIÓN)

CONCRETE REQUIRED / BÉTON REQUIS / CONCRETO REQUERIDO



1 yd<sup>3</sup> (≈0,77 m<sup>3</sup>)

### 1.1

#### CONCRETE PLATFORM / PLATE-FORME EN BÉTON / PLATAFORMA DE CONCRETO

- The concrete should be approximately 4 in (≈10,2 cm) thick. The actual dimensions of the shed, at its widest and longest points, are 96 in x 120 in (≈2,44 m x ≈3,05 m). Ensure you select a site that will accommodate these measurements. The floor dimensions are a bit smaller than those of the roof; therefore, you will need to build a level surface of 93 1/2 in x 118 1/4 in (≈2,38 m x ≈3,00 m).
- Le béton doit être un épaisseur de 4 po (≈10,2 cm). Les dimensions réelles de votre abri, aux points les plus large et long, sont 96 po x 120 po (≈2,44 m x ≈3,05 m). Assurez-vous de sélectionner un site qui accommodera ces dimensions. Les dimensions du plancher de votre abri sont plus petites que le toit; ensuite, il faut créer une surface nivelée de 93 1/2 po x 118 1/4 po (≈2,38 m x ≈3,00 m).
- El concreto debe tener, por lo menos, 4 in (≈10,2 cm) de espesor. Las dimensiones reales de la caseta, a sus puntos más ancho y largo, son 96 in x 120 in (≈2,44 m x ≈3,05 m). Asegúrese de seleccionar un sitio que acomodará estas medidas. Las dimensiones del piso de la caseta son más pequeñas que el tejado; entonces, necesitará crear una superficie nivelada de 93 1/2 in x 118 1/4 in (≈2,38 m x ≈3,00 m).

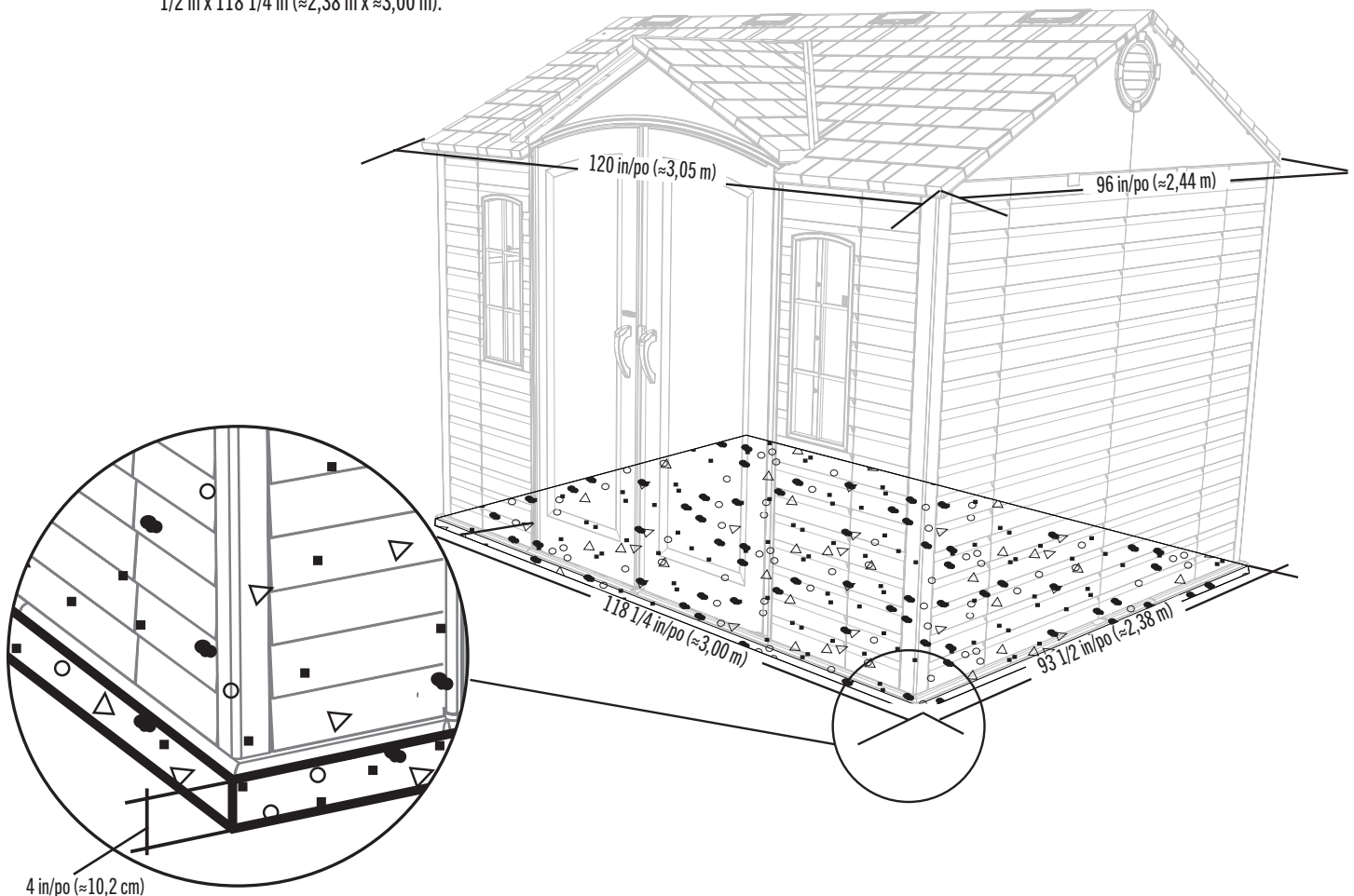

► SECTION 1 (CONTINUED) / SECTION 1 (SUITE) / SECCIÓN 1 (CONTINUACIÓN)

WOOD REQUIRED / BOIS REQUIS / MADERA REQUERIDA

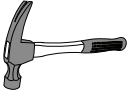

1.2

WOOD PLATFORM / PLATE-FORME EN BOIS / PLATAFORMA DE MADERA

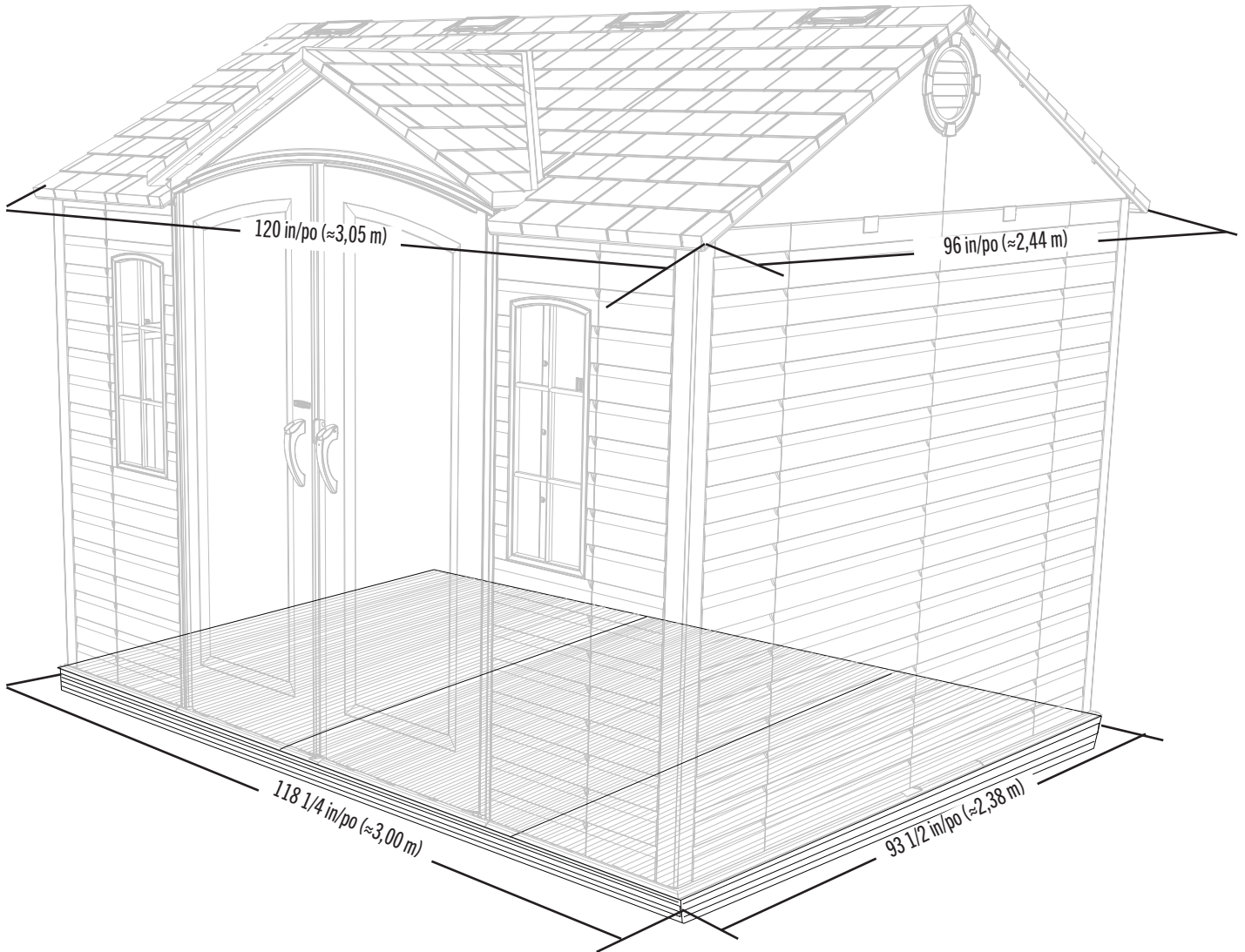



## SECTION 1 (CONTINUED) / SECTION 1 (SUITE) / SECCIÓN 1 (CONTINUACIÓN)

WOOD REQUIRED / BOIS REQUIS / MADERA REQUERIDA



2 in/po x 4 in/po x 118 1/4 in/po (≈5,1 cm x ≈10,2 cm x ≈3,00 m) (x2)

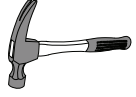

2 in/po x 4 in/po x 90 1/2 in/po (≈5,1 cm x ≈10,2 cm x ≈2,30 m) (x9)

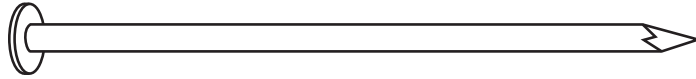

16d 3 in/po (≈16d x ≈7,62 cm) (x36)

### 1.2.1

- Ensure all lumber is treated and approved for outdoor use. Build frame to 93 1/2 in x 118 1/4 in (≈2,38 m x ≈3,00 m) (outside dimensions).
- Vérifiez que votre bois d'œuvre a été traité et approuvé pour l'utilisation à l'extérieur. Construisez un cadre de 93 1/2 po x 118 1/4 po (≈2,38 m x ≈3,00 m) (dimensions extérieures).
- Asegúrese de usar madera tratada y aprobada para el uso externo. Construya el armazón a 93 1/2 in x 118 1/4 in (≈2,38 m x ≈3,00 m) (dimensiones exteriores).



x8

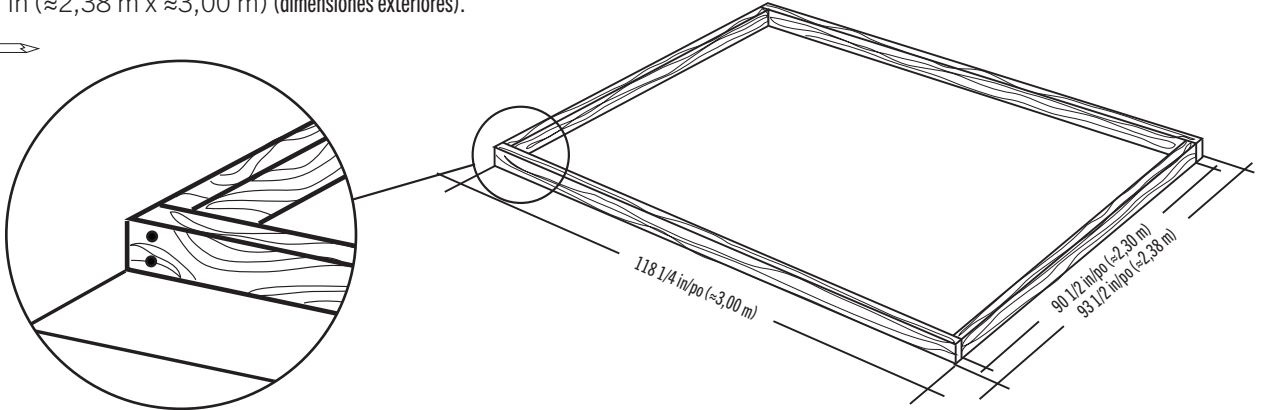

### 1.2.2

- To ensure studs are in the correct location for nailing plywood in the next step, start measuring from the corner 16 in (≈40,1 cm), and then measure from center to center.
- Pour être sûr d'avoir assez de montant pour clouer le contreplaqué dans la prochaine étape, commencez à mesurer à partir de cette montant 16 po (≈40,1 cm) vers le centre du deuxième montant. Ensuite, mesurez de centre à centre pour les montants restants.
- Para asegurarse que los montantes están en las ubicaciones correctas para el contrachapado en el paso siguiente, comience a medir desde el borde del montante hasta el centro del próximo montante 16 in (≈40,1 cm). Luego, tome la medida de centro a centro en los montantes restantes.



x28

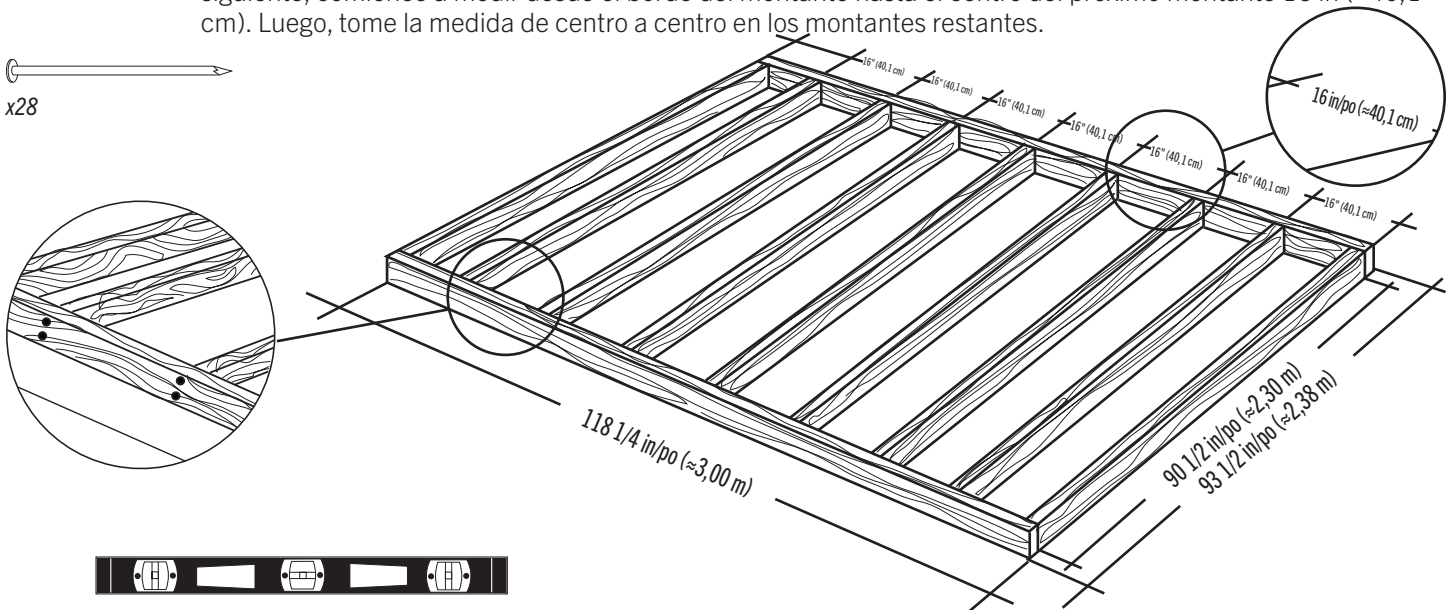

► SECTION 1 (CONTINUED) / SECTION 1 (SUITE) / SECCIÓN 1 (CONTINUACIÓN)

WOOD REQUIRED / BOIS REQUIS / MADERA REQUERIDA

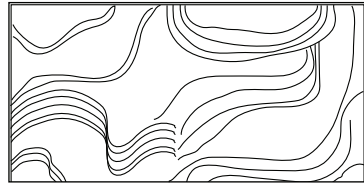
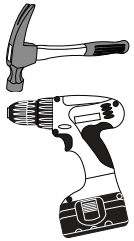

48 in/po x 93 1/2 in/po x 3/4 in/po  
(≈1,22 m x ≈2,38 m x ≈19,1 mm) (x2)



22 1/4 in/po x 93 1/2 in/po x 3/4 in/po  
(≈10,2 cm x ≈2,38 m x ≈19,1 mm) (x1)

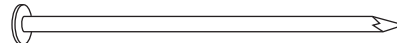

8d 1 1/2 in/po (8d ≈3,81 cm) (x66)

1.2.3

- Square the frame measuring from corner to corner.
- Carrez le cadre en mesurant d'angle à angle.
- Cuadre el armazón midiendo de esquina a esquina.

$A = B$

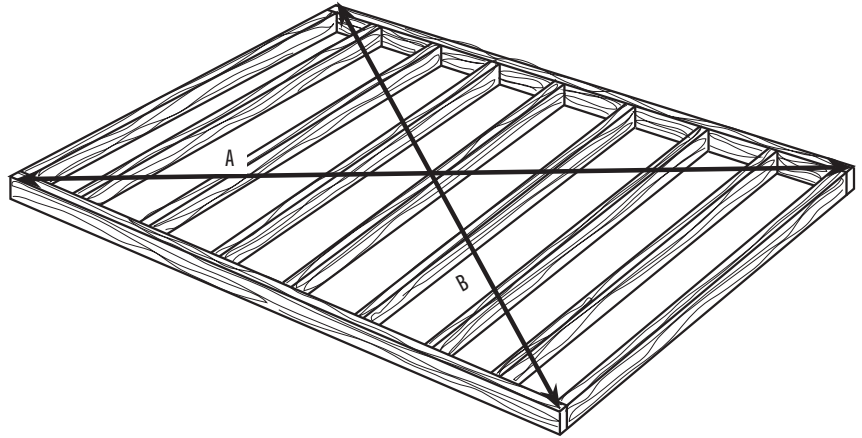

1.2.4

- Using nails, fasten the plywood to the frame. Then, drill holes for drainage.
- En utilisant des clous, attachez bien le contreplaqué au cadre. Ensuite, percez des trous de drainage.
- Usando unos clavos, sujete el contrachapado al armazón. Entonces, taladre agujeros para el drenaje.



x66

48 in/po x 93 1/2 in/po x 3/4 in/po  
(≈1,22 cm x ≈2,38 m x ≈19,1 mm)

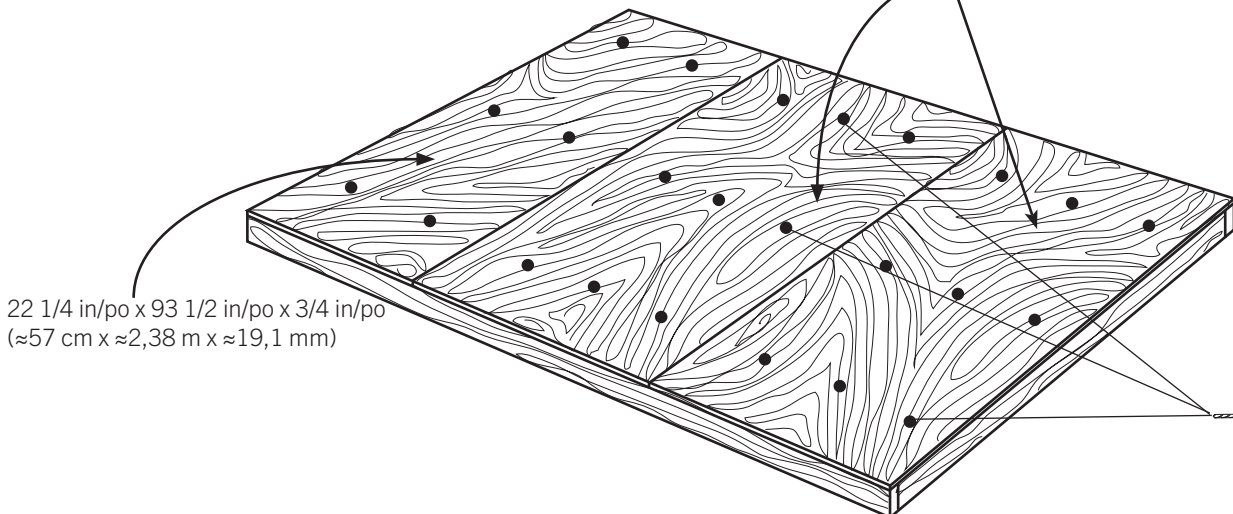

22 1/4 in/po x 93 1/2 in/po x 3/4 in/po  
(≈57 cm x ≈2,38 m x ≈19,1 mm)



- Drainage holes
- Trous de drainage
- Agujeros para canalización

x24!

# 2

## TRUSS ASSEMBLY / ASSEMBLAGE DES FERMES / ENSAMBLAJE DE LAS CERCHAS



### HARDWARE REQUIRED / QUINCAILLERIE REQUISE / HERRAJE REQUERIDO

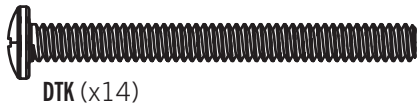

DTK (x14)



ADK (x24)



ADJ (x6)

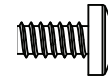

ADY (x11)



CXK (x2)



DTJ (x1)

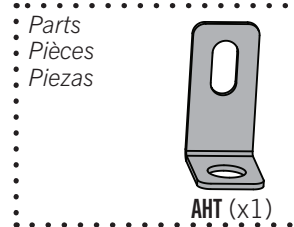

Parts  
Pièces  
Piezas



AHT (x1)



ADH (x3)



### PARTS REQUIRED / PIÈCES REQUISES / PIEZAS REQUERIDAS

Metal parts / Pièces en métal / Piezas de metal



DSP (x1)



DSQ (x2)

50 9/16 in/po (1,28 m)



DSR (x3)

50 9/16 in/po (1,28 m)

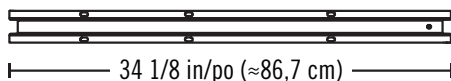

DSO (x1)

34 1/8 in/po (≈86,7 cm)

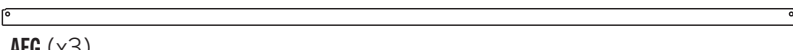

AFG (x3)

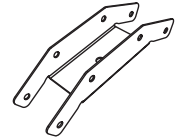
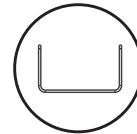

AIP (x3)



18 7/16 in/po (≈21,4 cm)

DSN (x1)



25 7/8 in/po (≈65,7 cm)

DSM (x1)

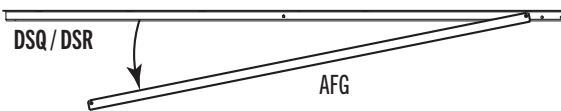

- Sometimes during shipping, the truss brace (AFG) slides over the back of the truss gutter channel (DSQ or DSR). The two pieces are the same color. If you think you're missing a truss brace, check to see if it is stuck to the back of the truss gutter channel, and separate the two.
- Durant le transport, parfois le support de ferme (AFG) glisse par-dessus l'arrière du canal de ferme (DSQ ou DSR). Les deux pièces sont du même couleur. Si vous pensez que vous n'avez pas de support de ferme, vérifiez s'il y a un support de ferme adhérent à l'arrière du canal de ferme, et séparez les deux.
- Durante el transporte, a veces el soporte de cercha (AFG) deslice sobre el dorso del canal de cercha (DSQ o DSR). Las dos piezas son de la misma color. Si piensas que le falta un soporte de cercha, verifique si haya un soporte pegado al dorso del canalón de cercha, y separe las dos.



### TOOLS REQUIRED / OUTILS REQUIS / INSTRUMENTAL REQUERIDO

(Not included—unless otherwise indicated\*) / (Non inclus — sauf indication contraire\*) / (No incluido, salvo indicación contraria\*)



7/16 in/po (≈11 mm) (x2)



3/8 in/po (≈10 mm)

## SECTION 2 (CONTINUED) / SECTION 2 (SUITE) / SECCIÓN 2 (CONTINUACIÓN)

TOOLS AND HARDWARE REQUIRED / OUTILS ET QUINCAILLERIE REQUIS / INSTRUMENTAL Y HERRAJE REQUERIDOS



3/8 in/po  
(≈10 mm)

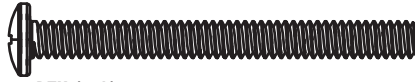

DTK (x4)



ADK (x4)



- In case of any trouble with this section, scan the QR code below to view a video on its assembly.
- En cas de problème avec cette section, scanner le QR code en dessous pour voir une vidéo de l'assemblage.
- En caso de problemas con esta sección, escanear el código QR debajo para ver un video del ensamblaje.



<http://go.lifetime.com/10x8-section2>

### 2.1

SIDE TRUSSES (x2) / CERCHAS LATERALES (x2) / FERMES LATÉRAUX (x2)

- Attach a **connector (AIP)** to the end of two **truss gutter channels (DSQ & DSR)** as shown.
- Attacher un **raccord (AIP)** à l'extrémité des **canaux de gouttière (DSQ & DSR)** comme indiqué.
- Sujetar un **connector (AIP)** a los extremos de los **canalones de la cercha (DSQ & DRS)** como se muestra.

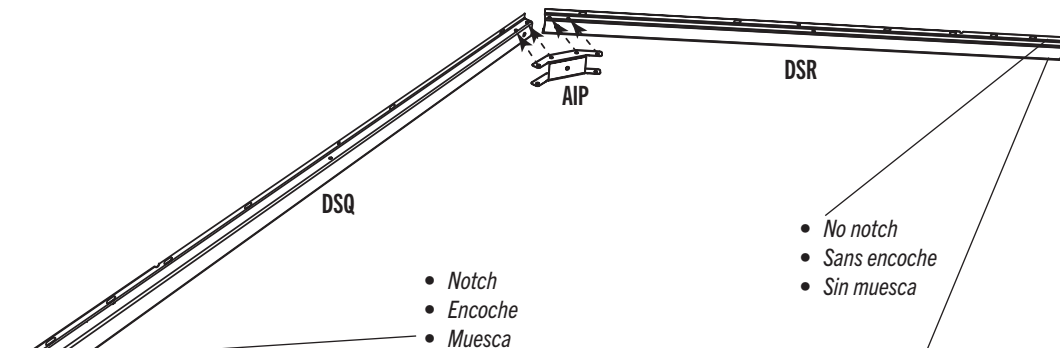

- Channel (DSR) has no notch at the end.
- Le canal (DSR) n'a pas d'encoche à l'extrémité.
- El canalón (DSR) no tiene una muesca al extremo.

### 2.2

- Secure a **connector (AIP)** to the end of the **truss gutter channels (DSQ & DSR)** as shown.
- Fixer un **raccord (AIP)** à l'extrémité des **canaux de gouttière (DSQ et DSR)** comme indiqué.
- Fijar un **connector (AIP)** a los extremos de los **canalones de la cercha (DSQ y DSR)** como se muestra.

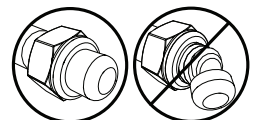
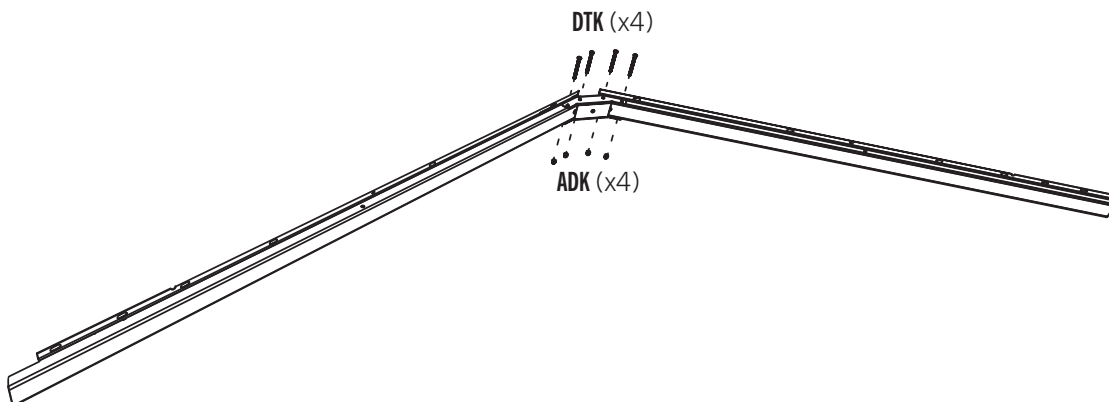

## ► SECTION 2 (CONTINUED) / SECTION 2 (SUITE) / SECCIÓN 2 (CONTINUACIÓN)

TOOLS AND HARDWARE REQUIRED / OUTILS ET QUINCAILLERIE REQUIS / INSTRUMENTAL Y HERRAJE REQUERIDOS



3/8 in/po  
(≈10 mm)

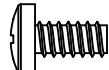

ADY (x4)



ADK (x4)

### 2.3

- Slide a **truss brace (AFG)** onto the truss gutter channels as shown.
- Faire glisser un **support de la ferme (AFG)** sur les canaux de gouttière comme indiqué.
- Deslizar un **sopORTE de la cercha (AFG)** sobre los canalones de la cercha como se muestra.

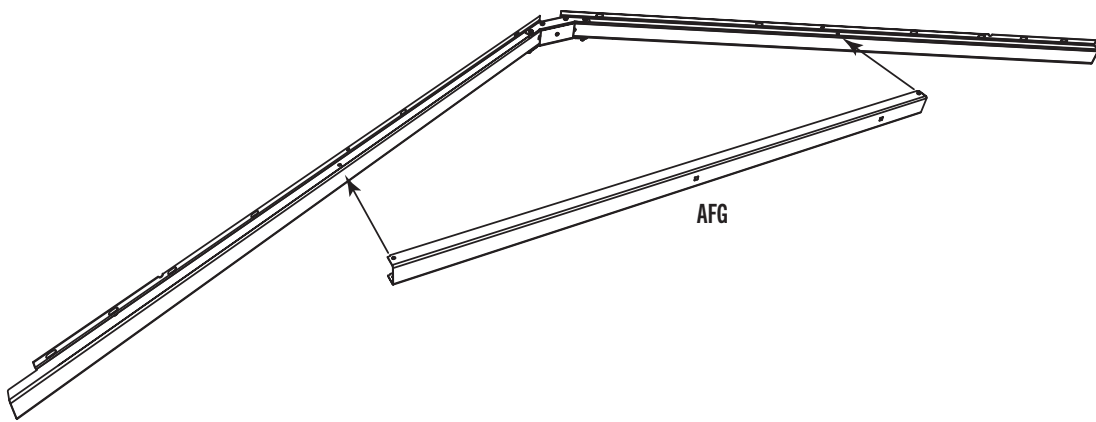

### 2.4

- Attach the truss brace using the hardware included. **Do not overtighten.**
- Attacher le support de la ferme à l'aide de la quincaillerie incluse. **Ne pas serrer excessivement.**
- Sujetar el soporte de la cercha usando el herraje incluido. **No apretar demasiado.**

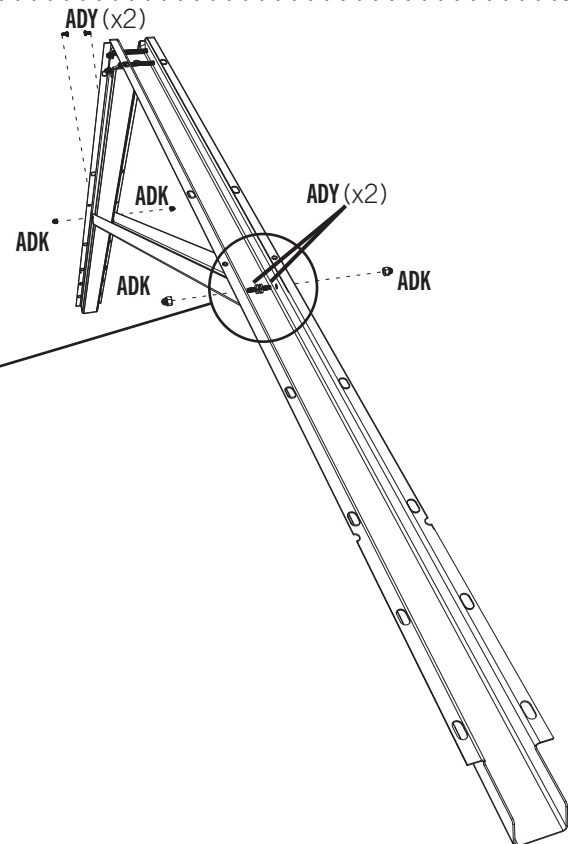
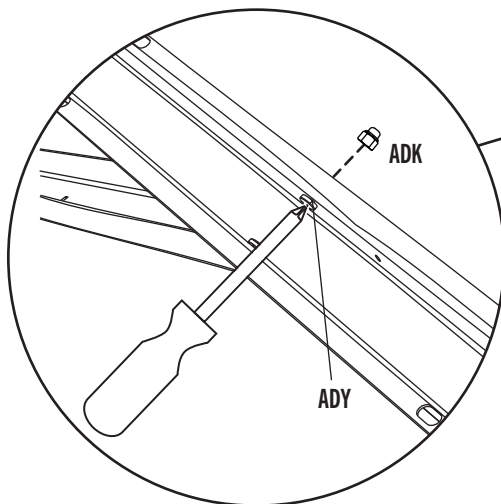

## SECTION 2 (CONTINUED) / SECTION 2 (SUITE) / SECCIÓN 2 (CONTINUACIÓN)

TOOLS AND HARDWARE REQUIRED / OUTILS ET QUINCAILLERIE REQUIS / INSTRUMENTAL Y HERRAJE REQUERIDOS



3/8 in/po  
(≈10 mm)

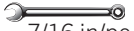

7/16 in/po  
(≈11 mm) (x2)

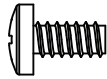

ADY (x4)



DTK (x4)

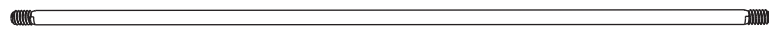

ADH (x1)



ADJ (x2)



ADK (x8)

### 2.5

- Slide a **truss rod (ADH)** through the holes in the brace and connector. Secure with two **cap nuts (ADJ)**.
- Faire glisser une **tige (ADH)** à travers les trous dans le support et le raccord. Bien l'attacher à l'aide de deux **écrous borgnes (ADJ)**.
- Deslizar una **varilla (ADH)** a través de los agujeros en el soporte y el conector. Sujetarla con dos **tuercas ciegas (ADJ)**.



- *This notched end will face the front of the shed.*
- *Cette extrémité encochée fera face à la partie avant de l'abri.*
- *Este extremo muescado dará a la parte delantera de la caseta.*

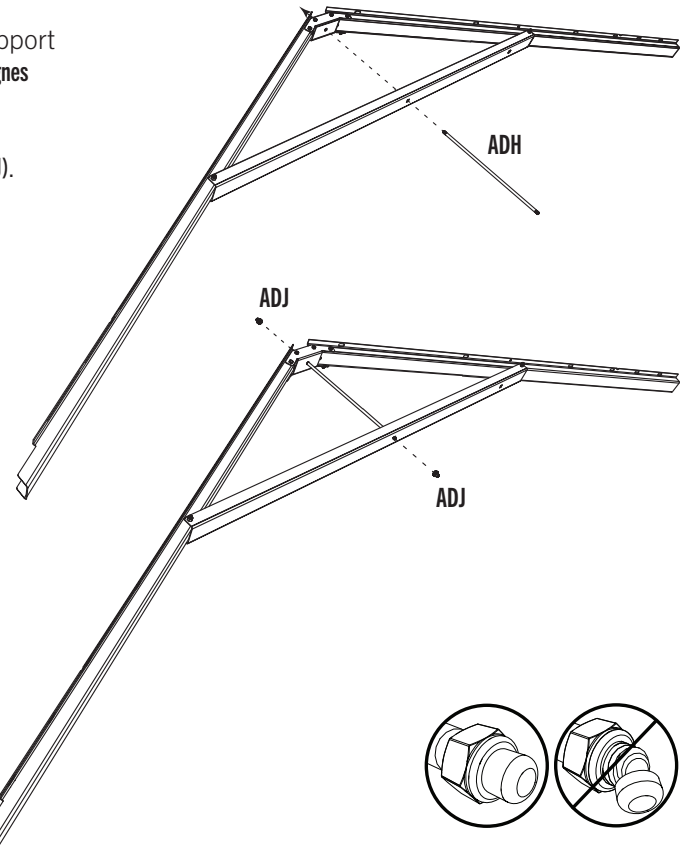

### 2.6

- Repeat the previous steps for a second side truss.
- Répéter les étapes précédentes pour une deuxième ferme latérale.
- Repetir los pasos anteriores para una segunda cercha lateral.

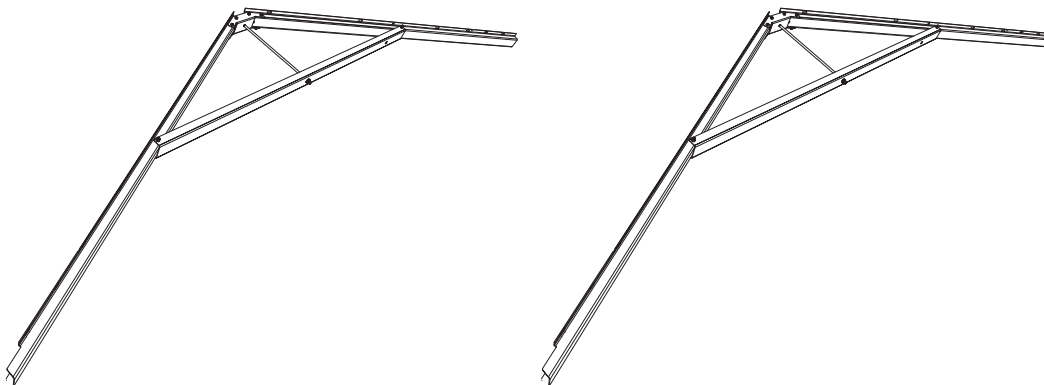

## ► SECTION 2 (CONTINUED) / SECTION 2 (SUITE) / SECCIÓN 2 (CONTINUACIÓN)

TOOLS AND HARDWARE REQUIRED / OUTILS ET QUINCAILLERIE REQUIS / INSTRUMENTAL Y HERRAJE REQUERIDOS



3/8 in/po  
(≈10 mm)



DTK (x4)



ADK (x4)

### 2.7

#### CENTER TRUSS (x1) / FERME CENTRALE (x1) / CERCHA CENTRAL (x1)

- Attach a **connector (AIP)** to the end of two **truss gutter channels (DSM & DSR)** as shown.
- Attacher un **raccord (AIP)** à l'extrémité des **canaux de gouttière (DSM & DSR)** comme indiqué.
- Sujetar un **connector (AIP)** a los extremos de los **canalones de la cercha (DSM & DRS)** como se muestra.

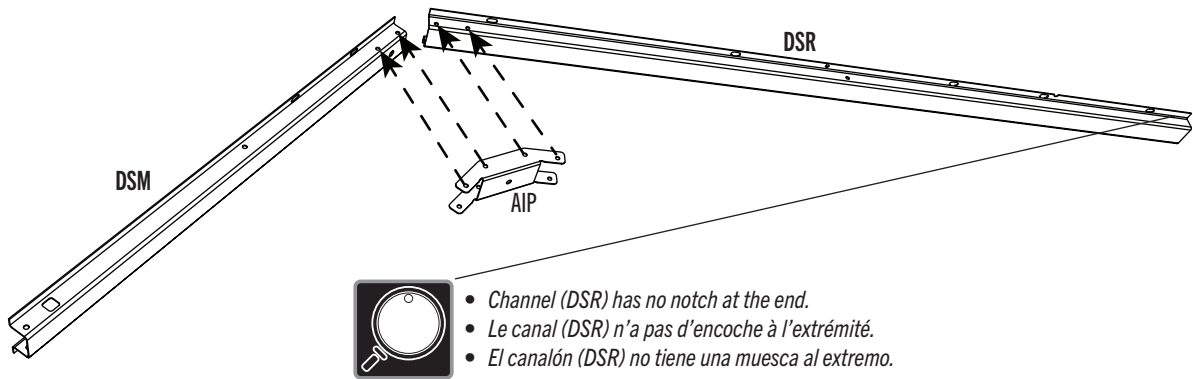

### 2.8

- Attach a **connector (AIP)** to the end of two **truss gutter channels (DSM, DSR)** using the hardware included. **Do not overtighten the cap nuts (ADK).**
- Attacher un **raccord (AIP)** à l'extrémité des **canaux de gouttière (DSM, DSR)** à l'aide de la quincaillerie incluse. **Ne pas trop serrer les écrous borgnes (ADK).**
- Sujetar un **connector (AIP)** a los extremos de los **canalones de la cercha (DSM, DSR)** usando el herraje incluido. **No apretar demasiado las tuercas ciegas (ADK).**

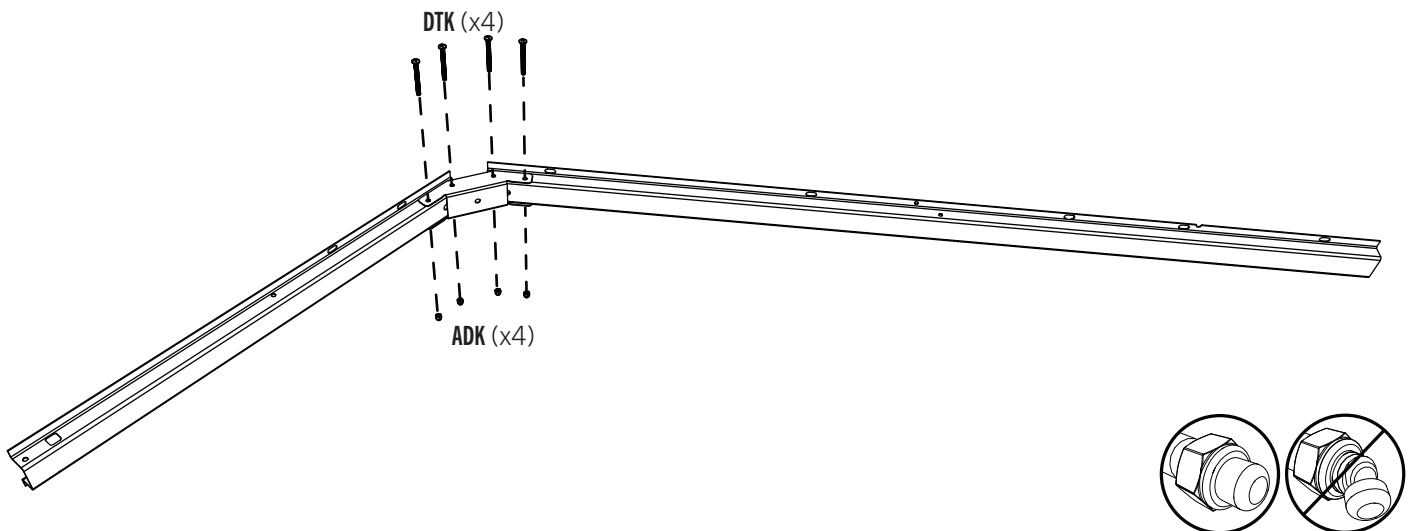

## ► SECTION 2 (CONTINUED) / SECTION 2 (SUITE) / SECCIÓN 2 (CONTINUACIÓN)

TOOLS AND HARDWARE REQUIRED / OUTILS ET QUINCAILLERIE REQUIS / INSTRUMENTAL Y HERRAJE REQUERIDOS



3/8 in/po  
(≈10 mm)

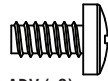

ADY (x2)



ADK (x2)

### 2.9

- Slide a **truss brace (AFG)** onto the truss gutter channels as shown.
- Faire glisser un **support de la ferme (AFG)** sur les canaux de gouttière comme indiqué.
- Deslizar un **soporte de la cercha (AFG)** sobre los canalones de la cercha como se muestra.

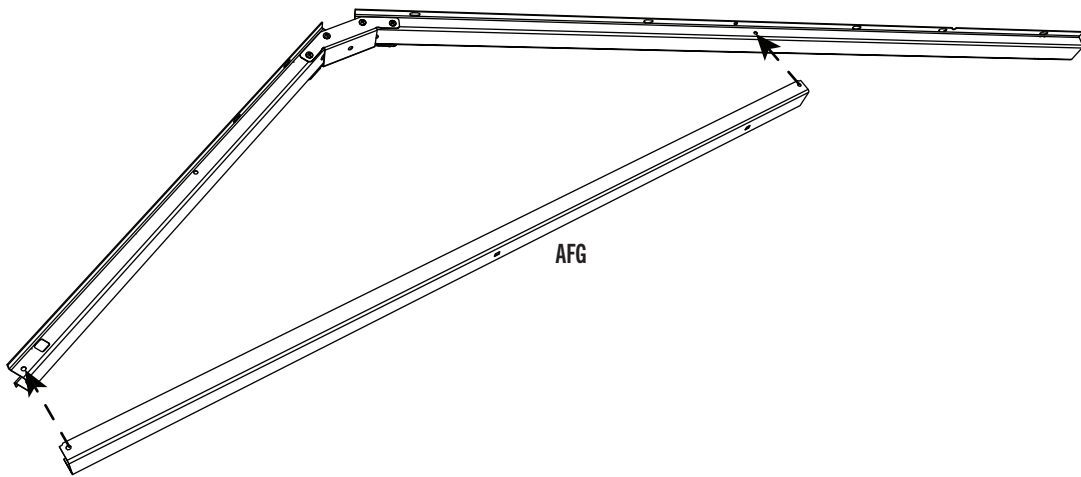

### 2.10

- Attach the truss brace using the hardware included. **Do not overtighten.**
- Attacher le support de la ferme à l'aide de la quincaillerie incluse. **Ne pas serrer excessivement.**
- Sujetar el soporte de la cercha usando el herraje incluido. **No apretar demasiado.**

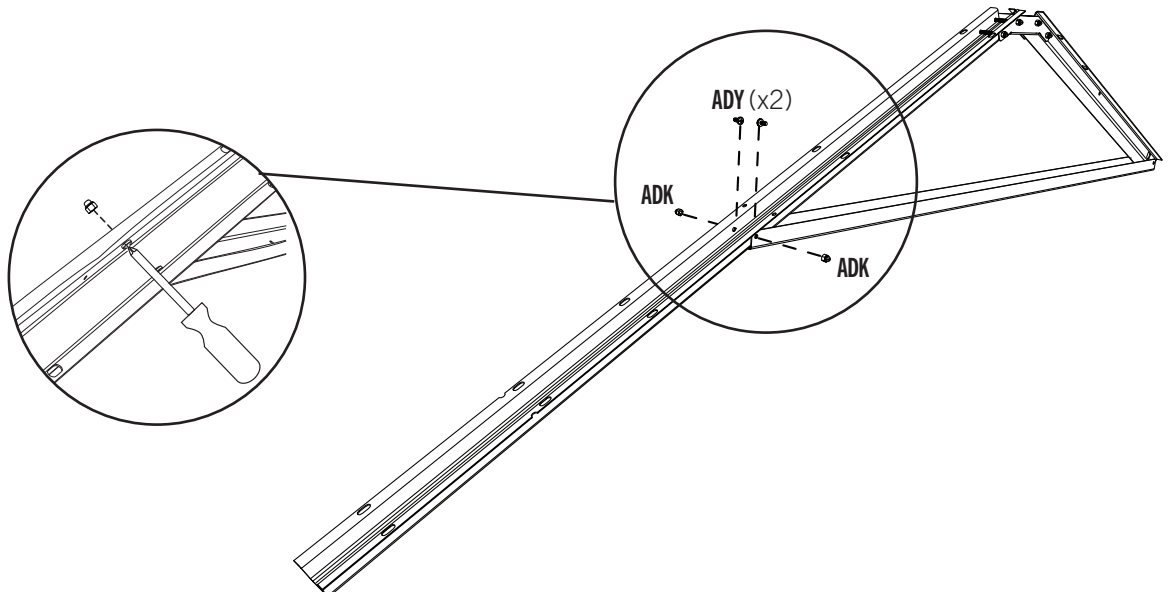



## ► SECTION 2 (CONTINUED) / SECTION 2 (SUITE) / SECCIÓN 2 (CONTINUACIÓN)

TOOLS AND HARDWARE REQUIRED / OUTILS ET QUINCAILLERIE REQUIS / INSTRUMENTAL Y HERRAJE REQUERIDOS



3/8 in/po  
(≈10 mm)



DTK (x2)

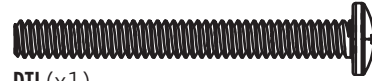

DTJ (x1)



CXK (x2)



ADK (x1)

### 2.11

- Attach the **vertical truss brace (DSN)** to the truss. Only finger tighten this **nut (ADK)** for now.
- Attacher le **support vertical (DSN)** à la ferme. Serrer l'**écrou (ADK)** à la main pour le moment.
- Fijar el **soporte vertical (DSN)** a la cercha. Apretar la **tuerca (ADK)** a mano por el momento.

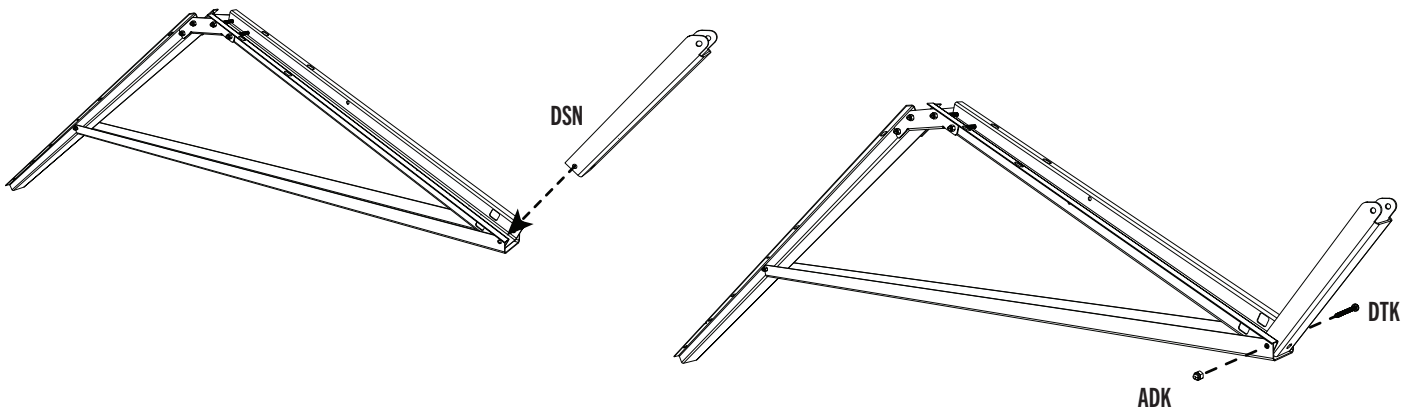

### 2.12

- Secure the **horizontal truss brace (DSO)** to the truss with the hardware included. **Now tighten the nut from step 2.11.**
- Attacher le **support horizontal (DSO)** à la ferme à l'aide de la quincaillerie incluse. **Maintenant, serrer l'écrou de l'étape 2.11.**
- Sujeter el **soporte horizontal (DSO)** a la cercha usando el herraje incluido. **Ahora, apretar la tuerca del paso 2.11.**

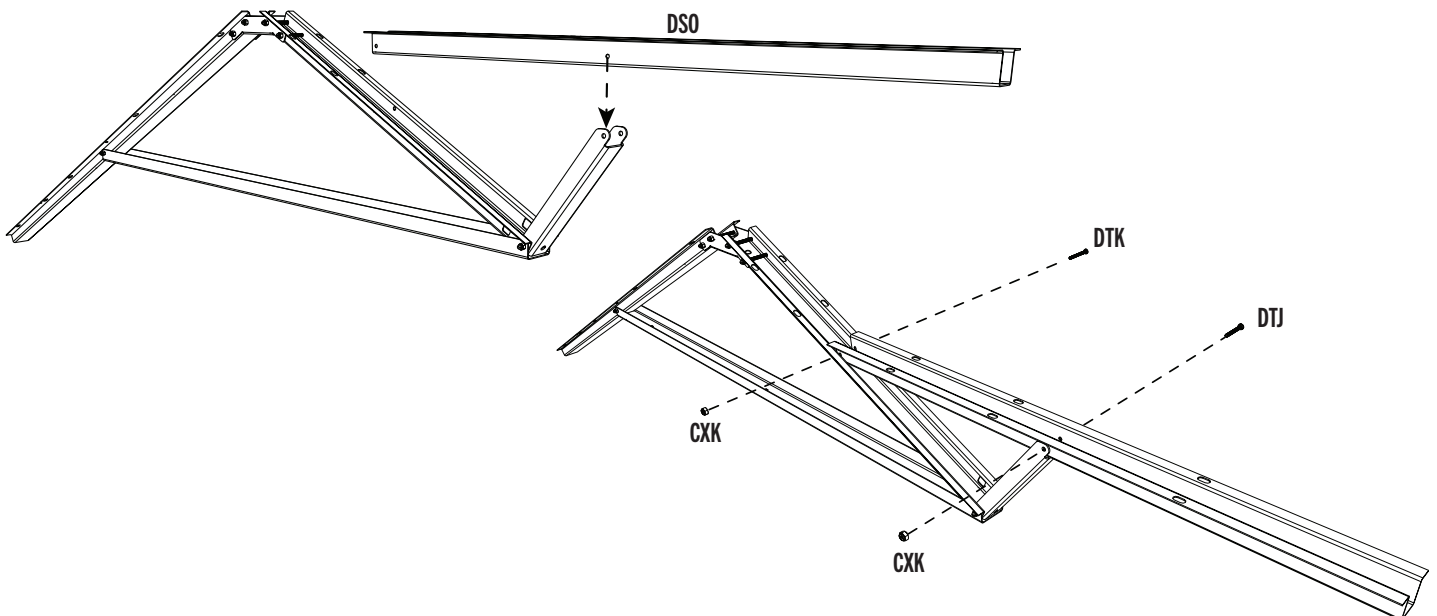

## ► SECTION 2 (CONTINUED) / SECTION 2 (SUITE) / SECCIÓN 2 (CONTINUACIÓN)

TOOLS AND HARDWARE REQUIRED / OUTILS ET QUINCAILLERIE REQUIS / INSTRUMENTAL Y HERRAJE REQUERIDOS

  
7/16 in/po  
(≈11 mm) (x2)

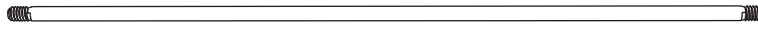

ADH (x1)



ADJ (x2)

### 2.13

- Slide a **truss rod (ADH)** through the holes in the brace and connector. Secure with two **cap nuts (ADJ)**.
- Faire glisser une **tige (ADH)** à travers les trous dans le support et le raccord. Bien l'attacher à l'aide de deux **écrous borgnes (ADJ)**.
- Deslizar una **varilla (ADH)** a través de los agujeros en el soporte y el conector. Sujetarla con dos **tuercas ciegas (ADJ)**.

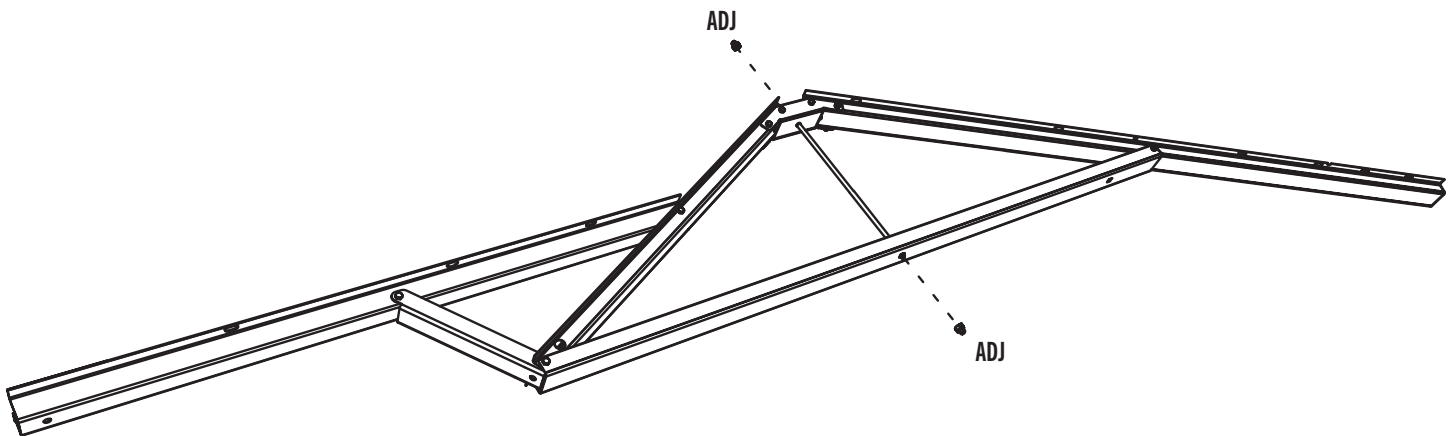
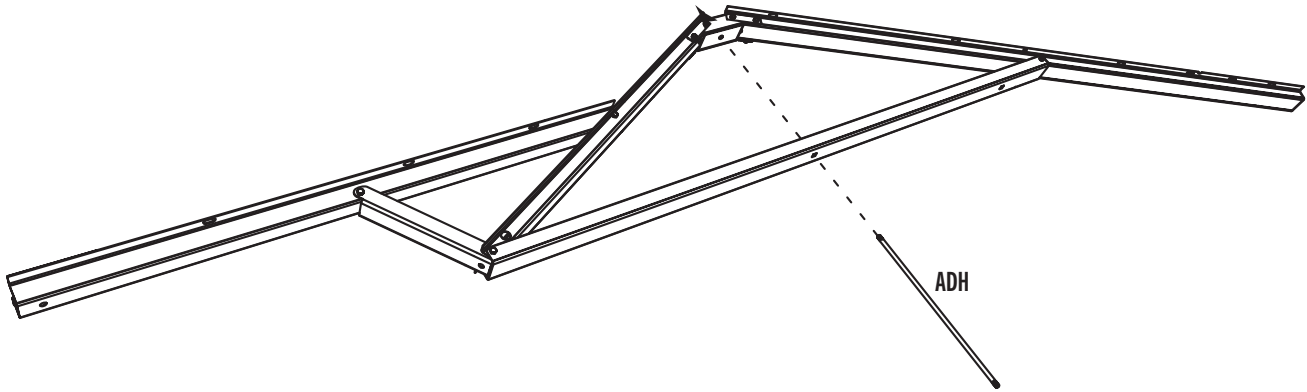

- Do not overtighten the cap nuts (ADJ).
- Ne pas trop serrer les écrous à chape (ADJ).
- No apretar demasiado las tuercas ciegas (ADJ).

## SECTION 2 (CONTINUED) / SECTION 2 (SUITE) / SECCIÓN 2 (CONTINUACIÓN)

TOOLS AND HARDWARE REQUIRED / Outils et quincaillerie requis / Instrumental y herraje requeridos

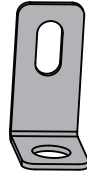
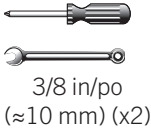

AHT (x1)

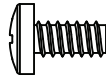

ADY (x1)



ADK (x1)

### 2.14

- Only tighten the **nut (ADK)** by hand in this step.
- Ne serrer l'**écrou (ADK)** qu'à la main dans cette étape.
- Apretar la **tuerca (ADK)** sólo à mano en este paso.

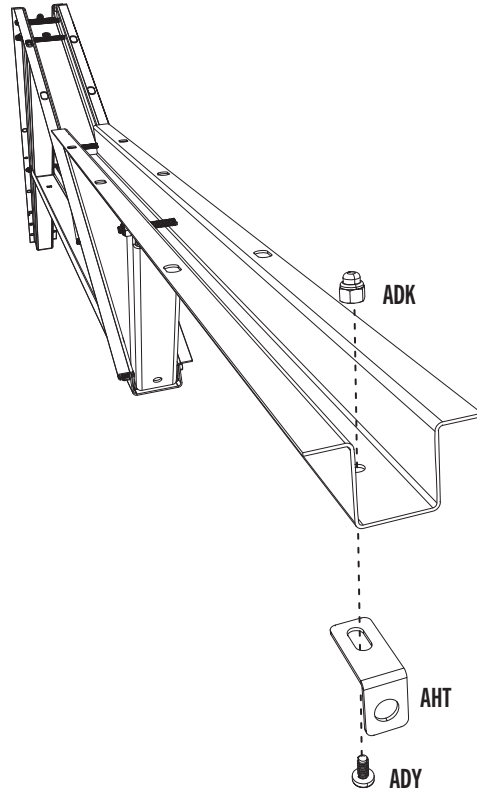

### 2.15

- Slide the **support tube (DSP)** through the hole in the front truss channel and center it.
- Faire glisser le **tube de support (DSP)** à travers le trou dans le canal de gouttière avant et le centrer.
- Deslizar el **tubo de soporte (DSP)** a través del agujero en el canalón de la cercha delantero y centrarlo.

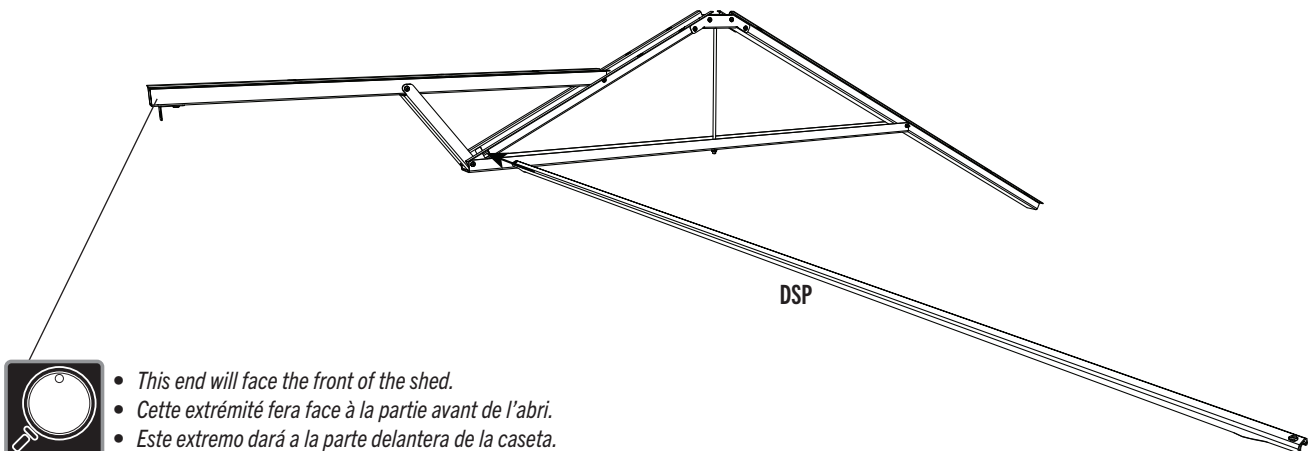

- This end will face the front of the shed.
- Cette extrémité fera face à la partie avant de l'abri.
- Este extremo dará a la parte delantera de la caseta.

# 3

## GABLE ASSEMBLY / ASSEMBLAGE DES PIGNONS / ENSAMBLAJE DE LAS FACHADAS



### HARDWARE REQUIRED / QUINCAILLERIE REQUISE / HERRAJE REQUERIDO

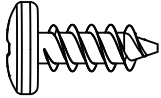
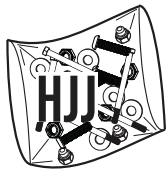

ADZ (x8)

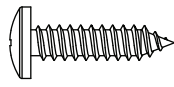

ADW (x10)

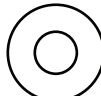

AEE (x10)

Parts / Pièces / Piezas

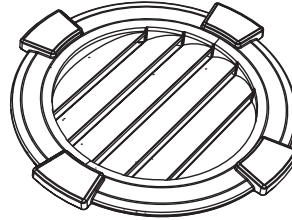

ENH (x2)

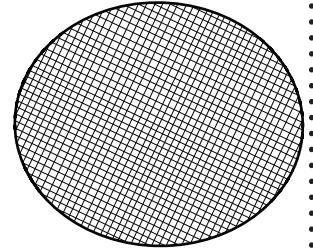

AIQ (x2)

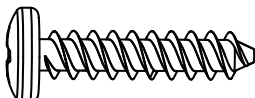
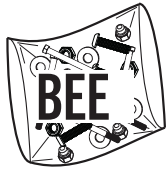

ADV (x4)

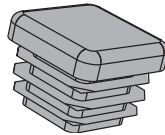

AHS (x2)



### PARTS REQUIRED / PIÈCES REQUISES / PIEZAS REQUERIDAS

Metal parts / Pièces en métal / Piezas de metal

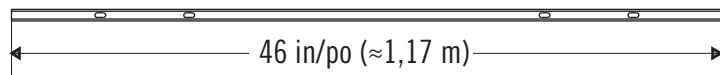

BDD (x1)

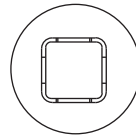

Plastic parts / Pièces en plastique / Piezas de plástico

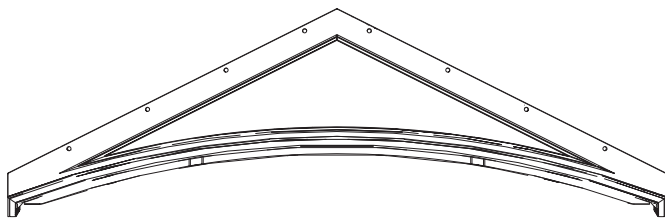

BDC (x1)

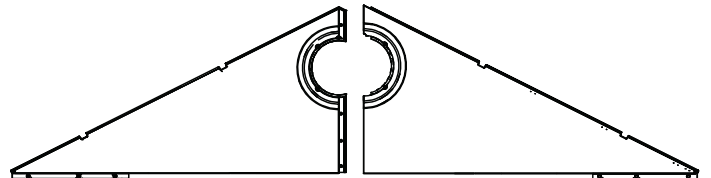

AGI (x2)

AGH (x2)



### TOOLS REQUIRED / OUTILS REQUIS / INSTRUMENTAL REQUERIDO

(Not included—unless otherwise indicated\*) / (Non inclus — sauf indication contraire\*) / (No incluido, salvo indicación contraria\*)



## ► SECTION 3 (CONTINUED) / SECTION 3 (SUITE) / SECCIÓN 3 (CONTINUACIÓN)

TOOLS AND HARDWARE REQUIRED / OUTILS ET QUINCAILLERIE REQUIS / INSTRUMENTAL Y HERRAJE REQUERIDOS

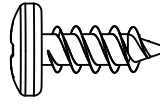

ADZ (x4)



- In case of any trouble with this section, scan the QR code below to view a video on its assembly.
- En cas de problème avec cette section, scanner le QR code en dessous pour voir une vidéo de l'assemblage.
- En caso de problemas con esta sección, escanear el código QR debajo para ver un video del ensamblaje.



<http://go.lifetime.com/10x8-section3>

### 3.1

- Align the holes in the **left (AGH)** and **right (AGI)** rear gable pieces.
- Aligner les trous dans les **pignons gauche (AGH)** et **droite (AGI)**.
- Alinear los agujeros en las **fachadas traseras izquierda (AGH)** y **derecha (AGI)**.

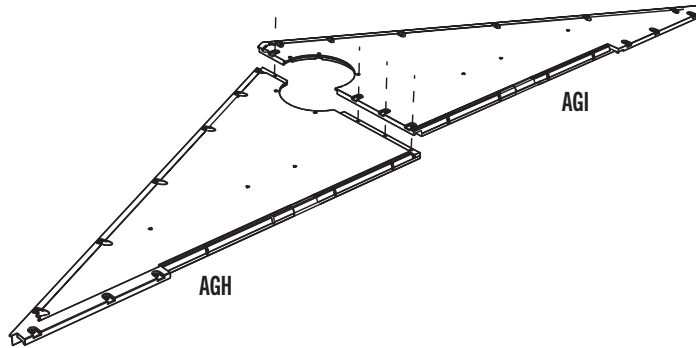

### 3.2

- Secure the two gable halves with four (4) screws (ADZ).
- Attacher l'un à l'autre à l'aide de quatre (4) vis (ADZ).
- Sujetar el uno al otro usando cuatro (4) tornillos (ADZ).

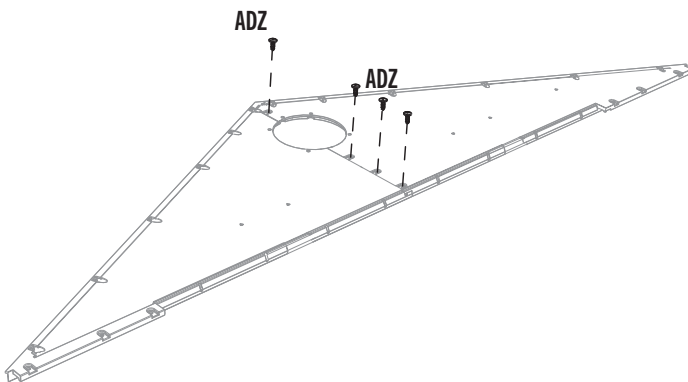

### 3.3

- Place the screen (AIQ) over the vent (ENH), and align the five holes in the vent with those in the gable.
- Mettre la moustiquaire (AIQ) sur l'évent (ENH), et aligner les cinq trous dans l'évent avec ceux du pignon.
- Colocar el mosquitero (AIQ) sobre la rejilla de ventilación (ENH), y alinear los agujeros en la rejilla con los de la fachada.

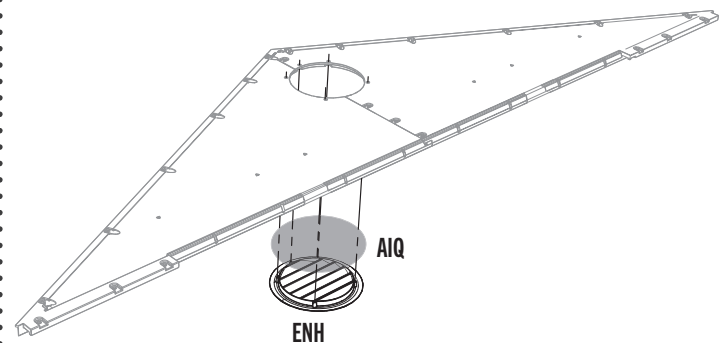

### SECTION 3 (CONTINUED) / SECTION 3 (SUITE) / SECCIÓN 3 (CONTINUACIÓN)

TOOLS AND HARDWARE REQUIRED / OUTILS ET QUINCAILLERIE REQUIS / INSTRUMENTAL Y HERRAJE REQUERIDOS

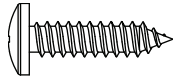

ADW (x10)

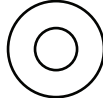

AEE (x10)

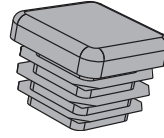

AHS (x2)

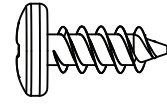

ADZ (x4)

## 3.4

- Secure with the hardware included.
- Attacher les uns aux autres de la quincaillerie incluse.
- Sujetar los unos a los otros usando el herraje incluido.

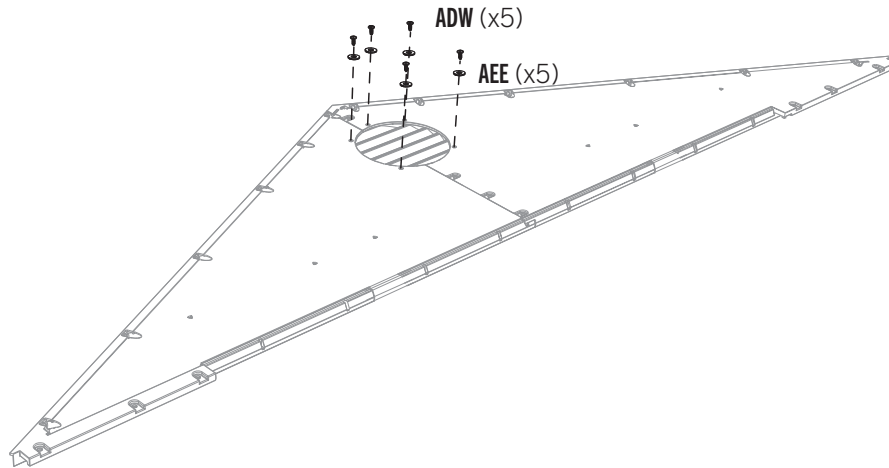

## 3.5

- Repeat the previous steps for the second vent.
- Répéter les étapes précédentes pour la deuxième évent.
- Repetir los pasos anteriores para la segunda rejilla.

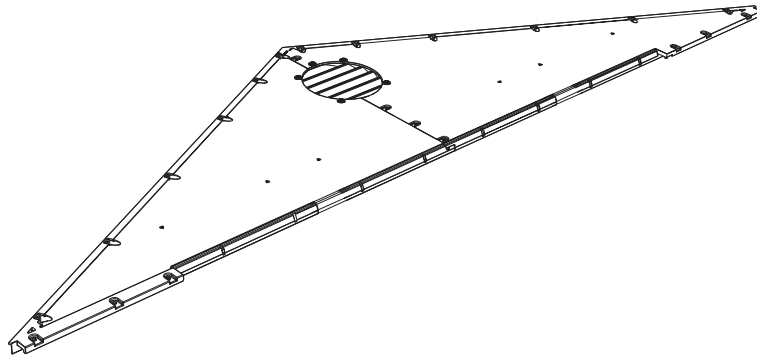

## 3.6

- Insert an end cap (AHS) into each end of the header bar (BDD).
- Insérer un capuchon (AHS) dans chaque extrémité du linteau (BDD).
- Insertar un tapón (AHS) en los dos extremos del dintel (BDD).

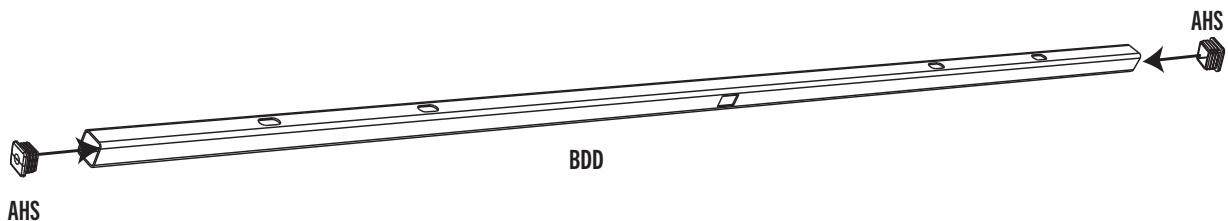

### ► SECTION 3 (CONTINUED) / SECTION 3 (SUITE) / SECCIÓN 3 (CONTINUACIÓN)

TOOLS AND HARDWARE REQUIRED / OUTILS ET QUINCAILLERIE REQUIS / INSTRUMENTAL Y HERRAJE REQUERIDOS

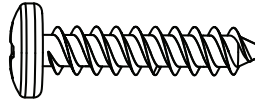

ADV (x4)

## 3.7

- Align the holes in the header with those in the entry gable. Secure with the hardware included.
- Aligner les trous dans le linteau avec ceux du pignon d'entrée. Attacher les uns aux autres à l'aide de la quincaillerie incluse.
- Alinear los agujeros en el dintel con ellos en la fachada de entrada. Sujetar los unos a los otros usando el herraje incluido.

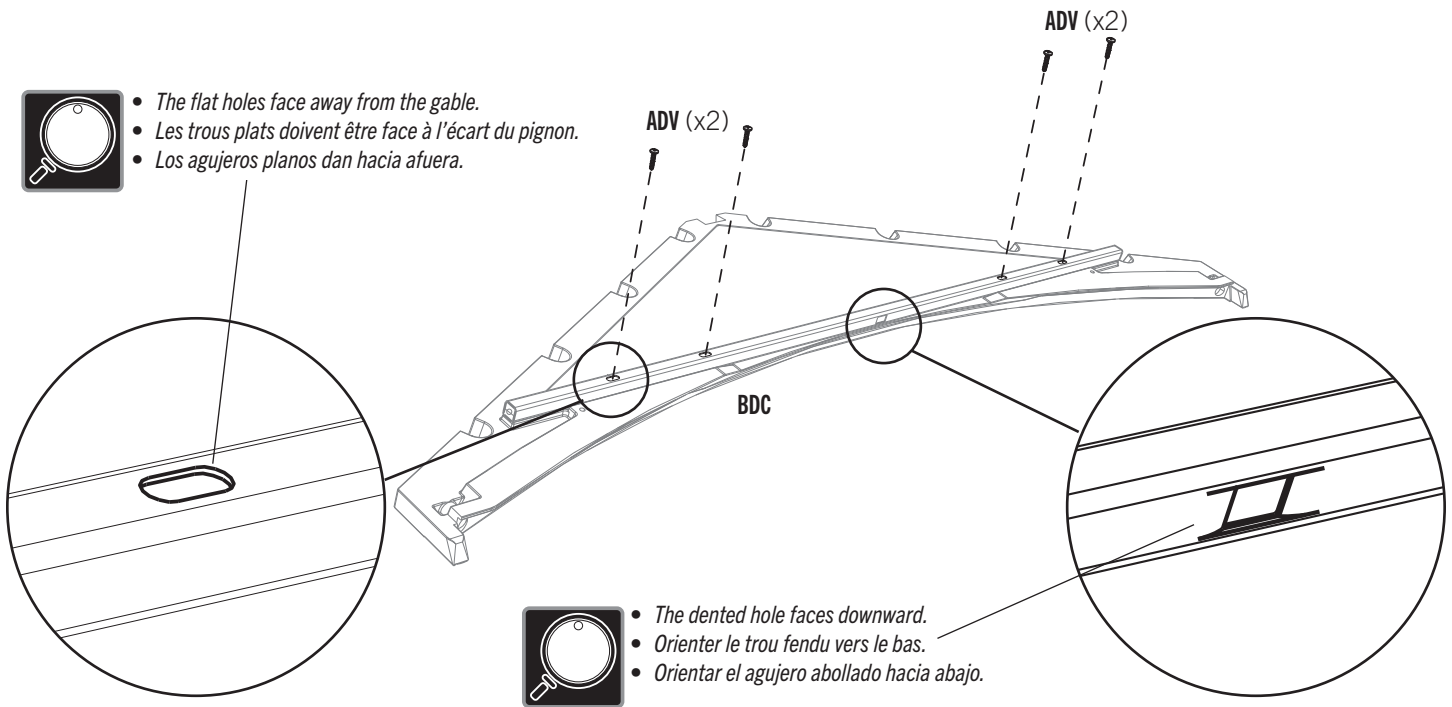

# 4

## LEFT DOOR ASSEMBLY / ASSEMBLAGE DE LA PORTE GAUCHE / ENSAMBLAJE DE LA PUERTA IZQUIERDA



### HARDWARE REQUIRED / QUINCAILLERIE REQUISE / HERRAJE REQUERIDO

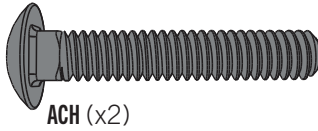

ACH (x2)

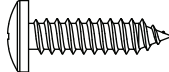

ADW (x1)

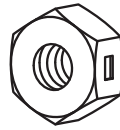

AAB (x2)

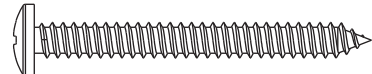

BYZ (x2)

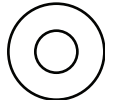

AEE (x3)

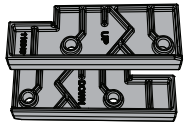

ENP (x2)

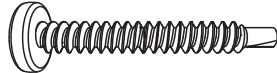

ENO (x4)



AEB (x2)

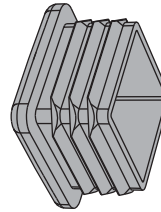

BBH (x1)



ARA (x1) 1/8 in/po (≈3 mm)

Parts / Pièces / Piezas

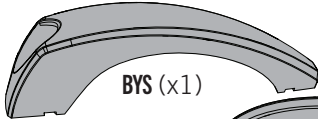

BYS (x1)



BYR (x1)

Parts / Pièces / Piezas

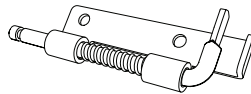

DGS (x1)

Upper / Supérieur / Superior

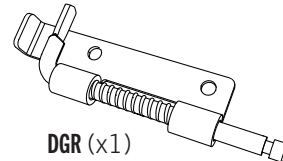

DGR (x1)

Lower / Inférieur / Inferior

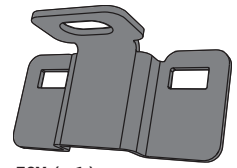

EOY (x1)



### PARTS REQUIRED / PIÈCES REQUISES / PIEZAS REQUERIDAS

Metal parts / Pièces en métal / Piezas de metal



Top end / Extrémité supérieure / Extremo superior



EDW (x1)

74 2/3" (1,9 m)

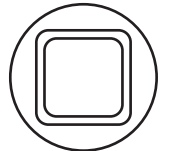

CRE (x1)

74 1/2 in/po (≈1,89 m)

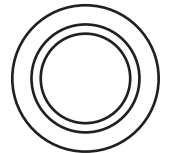

Plastic parts / Pièces en plastique / Piezas de plástico

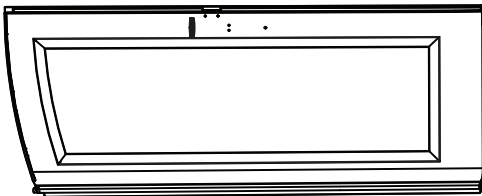

BDJ (x1)



### TOOLS REQUIRED / OUTILS REQUIS / INSTRUMENTAL REQUERIDO

(Not included—unless otherwise indicated\*) / (Non inclus—sauf indication contraire\*) / (No incluido, salvo indicación contraria\*)

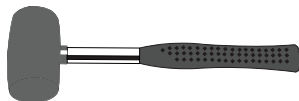

ARA (x1) 1/8 in/po (≈3 mm)\*





## ► SECTION 4 (CONTINUED) / SECTION 4 (SUITE) / SECCIÓN 4 (CONTINUACIÓN)

TOOLS AND HARDWARE REQUIRED / OUTILS ET QUINCAILLERIE REQUIS / INSTRUMENTAL Y HERRAJE REQUERIDOS

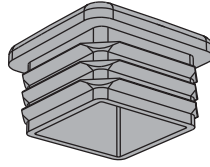

BBH (x1)



- In case of any trouble with this section, scan the QR code below to view a video on its assembly.
- En cas de problème avec cette section, scanner le QR code en dessous pour voir une vidéo de l'assemblage.
- En caso de problemas con esta sección, escanear el código QR debajo para ver un video del ensamblaje.



<http://go.lifetime.com/10x8-section4>

### 4.1

- Slide a **long tube (EDW)** into the hole in the **left door (BDJ)** until a few inches remain out of the door. **The end with the hole goes at the top.**
- Faites glisser le **tube grand (EDW)** à travers le trou de la **porte gauche (BDJ)** jusqu'à ce qu'il dépasse quelques pouces de la porte. **L'extrémité avec le trou va vers le haut.**
- Deslice el **tubo largo (EDW)** adentro del agujero en la **puerta izquierda (BDJ)** hasta que el tubo cuelgue unas pulgadas de la puerta. **El extremo con el agujero va al tope.**

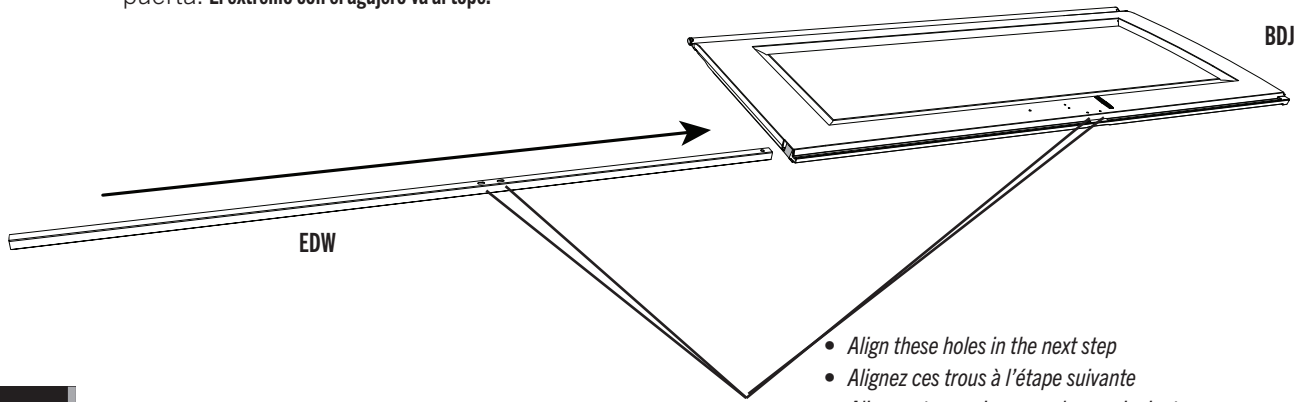

- *Align these holes in the next step*
- *Alignez ces trous à l'étape suivante*
- *Alinee estos agujeros en el paso siguiente*

### 4.2

- Insert an **end cap (BBH)** into the end of the tube and finish inserting the tube until flush with bottom of door and the two holes in the tube align with those in the door.
- Insérez un **capuchon (BBH)** dans l'extrémité du tube et continuez d'insérer le tube jusqu'à ce qu'il soit à ras au bord inférieur de la porte et les deux trous dans le tube s'alignent avec ceux dans la porte.
- Inserte un **tapon (BBH)** adentro del extremo del tubo y siga con la inserción del tubo hasta que esté al ras del borde inferior de la puerta y los dos agujeros en el tubo se alineen con ellos en la puerta.

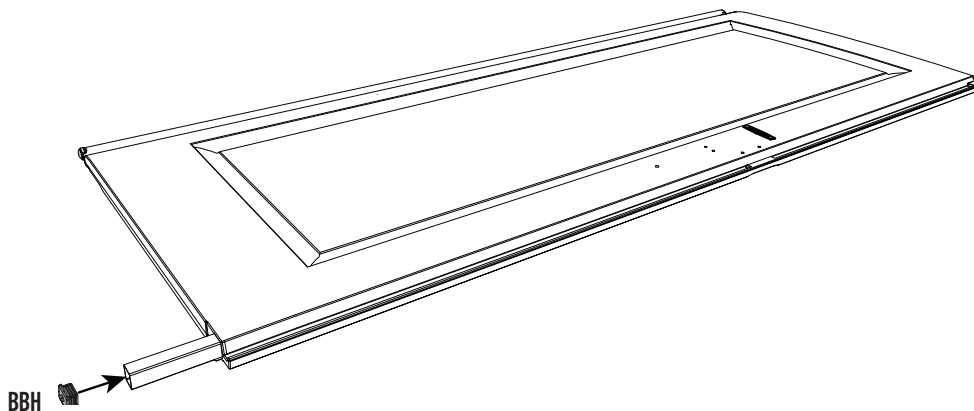

## ► SECTION 4 (CONTINUED) / SECTION 4 (SUITE) / SECCIÓN 4 (CONTINUACIÓN)

TOOLS AND HARDWARE REQUIRED / OUTILS ET QUINCAILLERIE REQUIS / INSTRUMENTAL Y HERRAJE REQUERIDOS

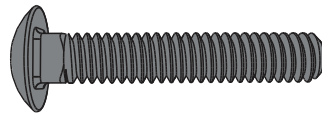

ACH (x2)

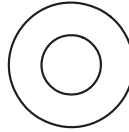

AEB (x2)

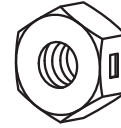

AAB (x2)

### 4.3

- Attach the **left latch bracket (EOY)** to the door using the hardware included.
- Attachez le **support gauche à loquet (EOY)** à la porte à l'aide de la quincaillerie incluse.
- Sujete el **soporte izquierdo para el pestajo (EOY)** a la puerta usando el herraje incluido.

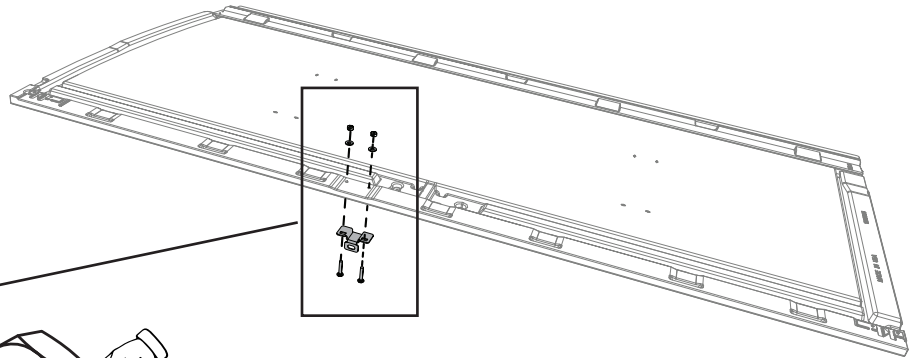
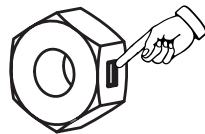
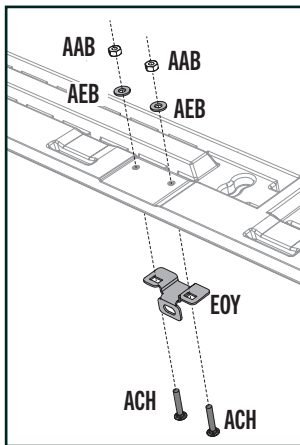

### 4.4

- Drill into the divots at the top and bottom of the door and into the tube inside but not all the way through the door. Use the **1/8" (≈3 mm) drill bit (ARA)** included.
- Percez les marques à la partie supérieure et inférieure de la porte et dedans le tube à l'intérieur mais pas à travers la porte entière. Utilisez le **foret de ≈3 mm (1/8 po) (ARA)** inclus.
- Taladre las marcas al tope y al fondo de la puerta y dentro del tubo adentro mas no por la puerta entera. Use la **broca de ≈3 mm (1/8 in.) (ARA)** incluida.

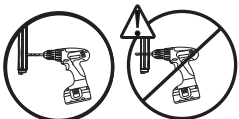
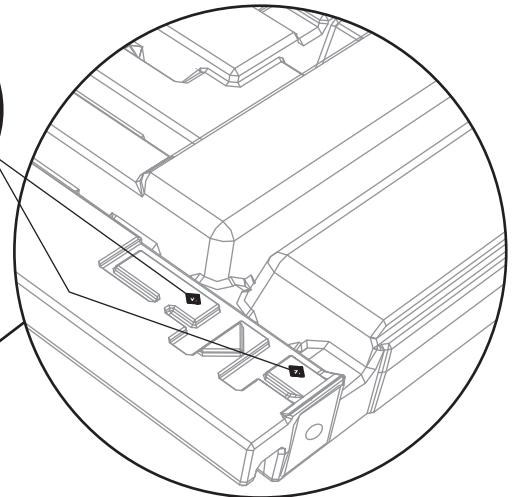

## SECTION 4 (CONTINUED) / SECTION 4 (SUITE) / SECCIÓN 4 (CONTINUACIÓN)

TOOLS AND HARDWARE REQUIRED / OUTILS ET QUINCAILLERIE REQUIS / INSTRUMENTAL Y HERRAJE REQUERIDOS

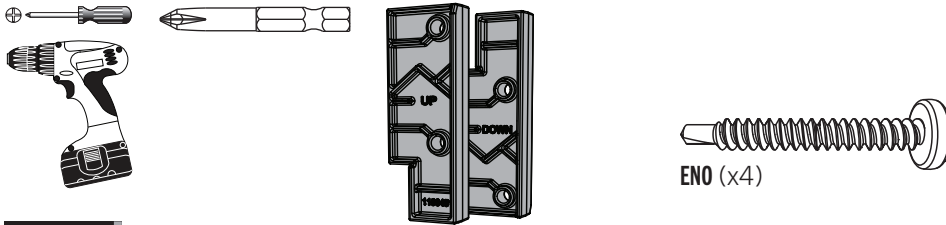

ENO (x4)

ENP (x2)

### 4.5

- Attach the locks (DGR & DGS) and spacers (ENP) to the top and bottom of the left door. If the pins in the locks do not move freely, loosen the screws (ENO) just a tad.
- Attachez les verrous (DGR et DGS) et les pièces d'écartement (ENP) à la partie supérieure et inférieure à la porte gauche. Si les verrous ne se déplacent pas librement, deserre les vis (ENO) un petit peu.
- Sujete los pasadores (DGR y DGE) y los espaciadores (ENP) al tope y al fondo de la Puerta izquierda. Si los pasadores no se mueven libremente, afloje los tornillos (ENO) un poquito.

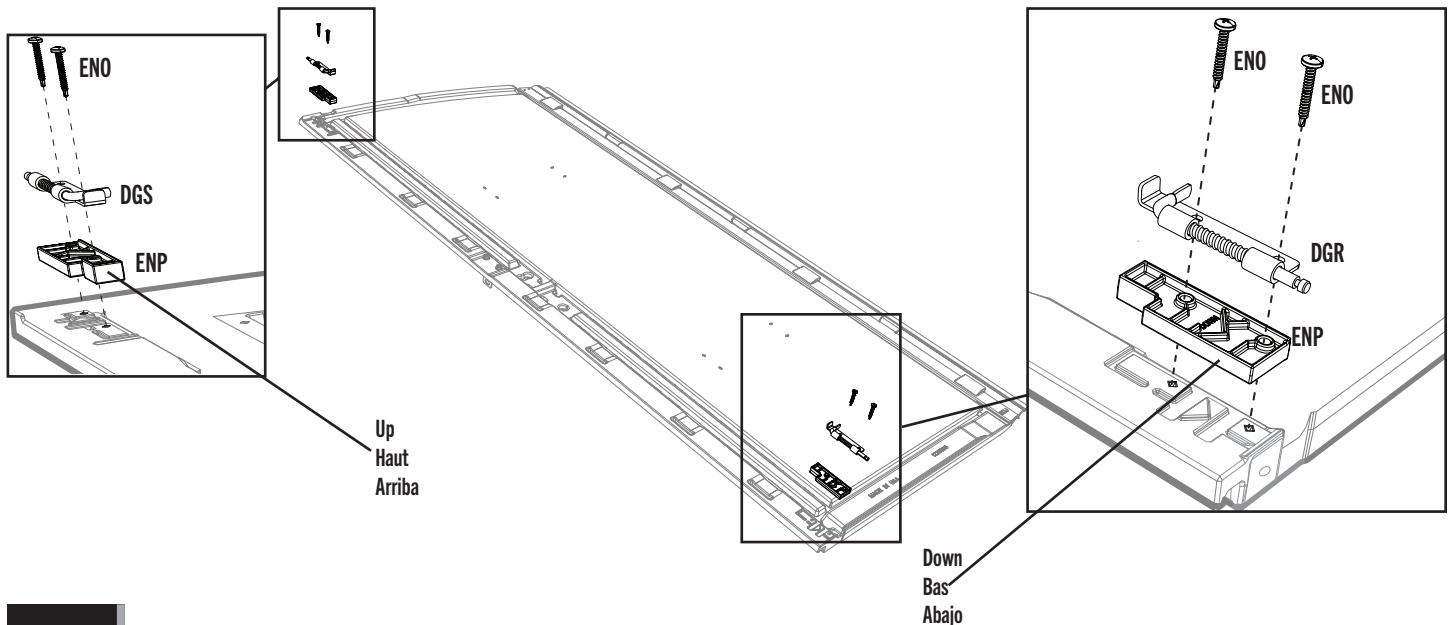

### 4.6

- Attach the two handle pieces (BYR & BYS) together as shown.
- Attachez les deux pièces de la poignée (BYR et BYS) comme illustré.
- Conecte las dos piezas del picaporte (BYR y BYS) como se muestra.

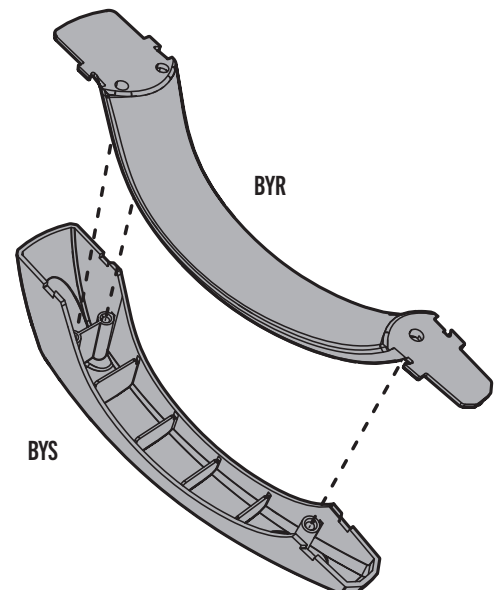

## ► SECTION 4 (CONTINUED) / SECTION 4 (SUITE) / SECCIÓN 4 (CONTINUACIÓN)

TOOLS AND HARDWARE REQUIRED / OUTILS ET QUINCAILLERIE REQUIS / INSTRUMENTAL Y HERRAJE REQUERIDOS

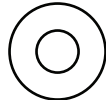
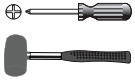

AEE (x3)

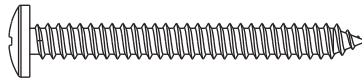

BYZ (x2)

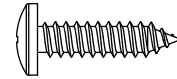

ADW (x1)

### 4.7

- Attach the handle to the door using the hardware included.
- Attachez la poignée à la porte à l'aide de la quincaillerie incluse.
- Sujete el picaporte a la puerta usando el herraje incluido.

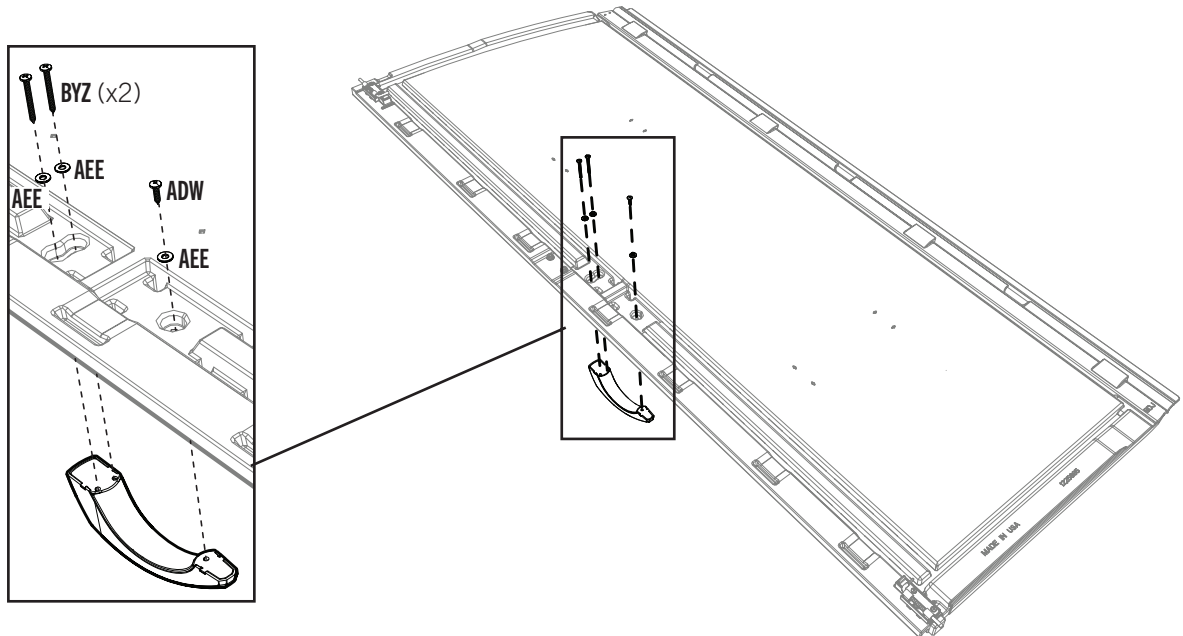

### 4.8

- Slide a **hinge tube (CRE)** into the hole in the door until a few inches remain out of the bottom.
- Faites glisser le **tube de charnière (CRE)** à travers le trou de la porte jusqu'à ce qu'il dépasse quelques pouces de la partie inférieure de la porte.
- Deslice un **tubo de bisagra (CRE)** adentro del agujero en la puerta hasta que el tubo cuelgue unas pulgadas de la parte inferior de la puerta.

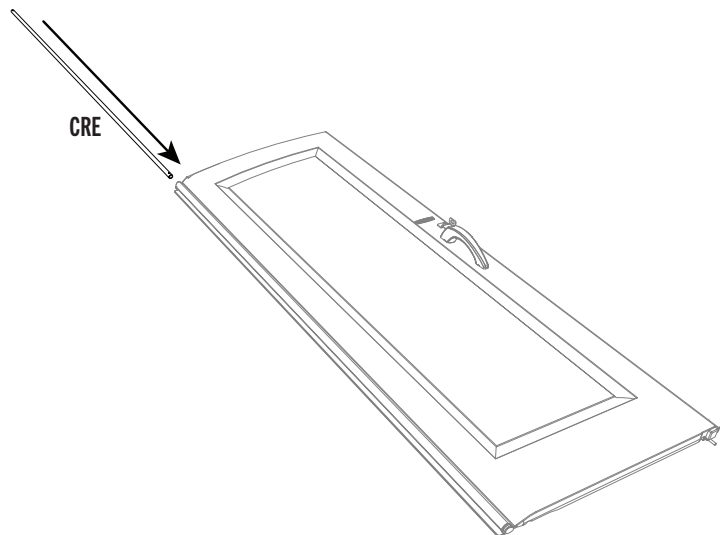

# 5

## RIGHT DOOR ASSEMBLY / ASSEMBLAGE DE LA PORTE DROITE / ENSAMBLAJE DE LA PUERTA DERECHA



### HARDWARE REQUIRED / QUINCAILLERIE REQUISE / HERRAJE REQUERIDO

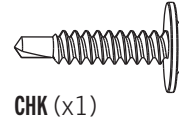
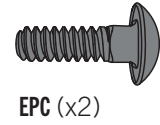
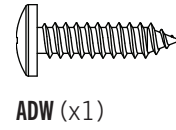
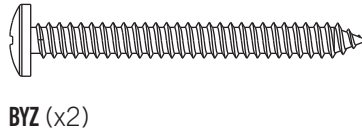
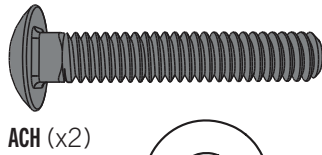

*Parts / Pièces / Piezas*

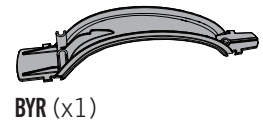
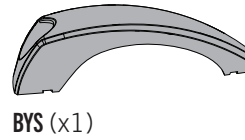
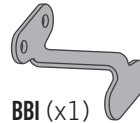
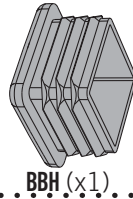
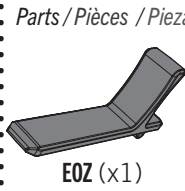

### PARTS REQUIRED / PIÈCES REQUISES / PIEZAS REQUERIDAS

*Metal parts / Pièces en métal / Piezas de metal*

*Top end / Extrémité supérieure / Extremo superior*

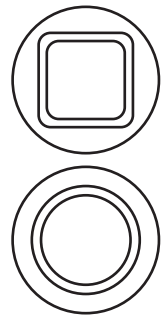
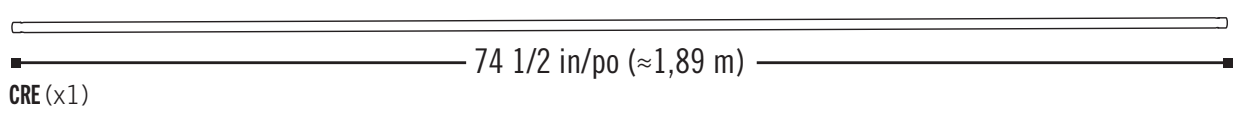
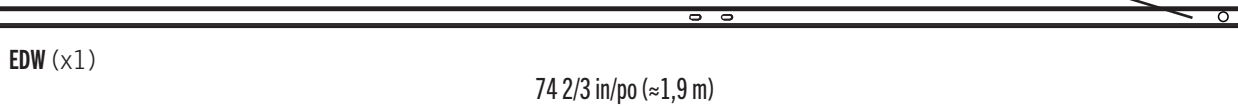

*Plastic parts / Pièces en plastique / Piezas de plástico*



### TOOLS REQUIRED / OUTILS REQUIS / INSTRUMENTAL REQUERIDO

*(Not included—unless otherwise indicated\*) / (Non inclus — sauf indication contraire\*) / (No incluido, salvo indicación contraria\*)*

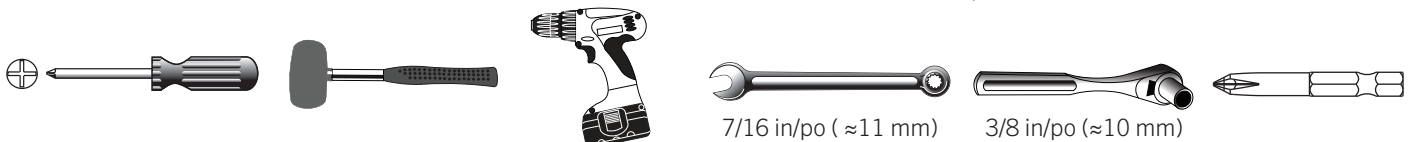

## ► SECTION 5 (CONTINUED) / SECTION 5 (SUITE) / SECCIÓN 5 (CONTINUACIÓN)

TOOLS AND HARDWARE REQUIRED / OUTILS ET QUINCAILLERIE REQUIS / INSTRUMENTAL Y HERRAJE REQUERIDOS

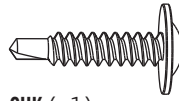

CHK (x1)

- In case of any trouble with this section, scan the QR code below to view a video on its assembly.
- En cas de problème avec cette section, scanner le QR code en dessous pour voir une vidéo de l'assemblage.
- En caso de problemas con esta sección, escanear el código QR debajo para ver un video del ensamblaje.



<http://go.lifetime.com/10x8-section5>

### 5.1

- Slide a **square tube (EDW)** into the hole in the **right door (BDK)** until a few inches remain out of the door. **The end with the hole goes at the top.**
- Faire glisser le **tube carré (EDW)** à travers le trou de la **porte droite (BDK)** jusqu'à ce qu'il dépasse de quelques centimètres de la porte. **L'extrémité avec le trou va en haut.**
- Deslizar el **tubo cuadrado (EDW)** adentro del agujero en la **puerta derecha (BDK)** hasta que el tubo cuelgue unas pulgadas de la puerta. **El extremo con el agujero va al tope.**

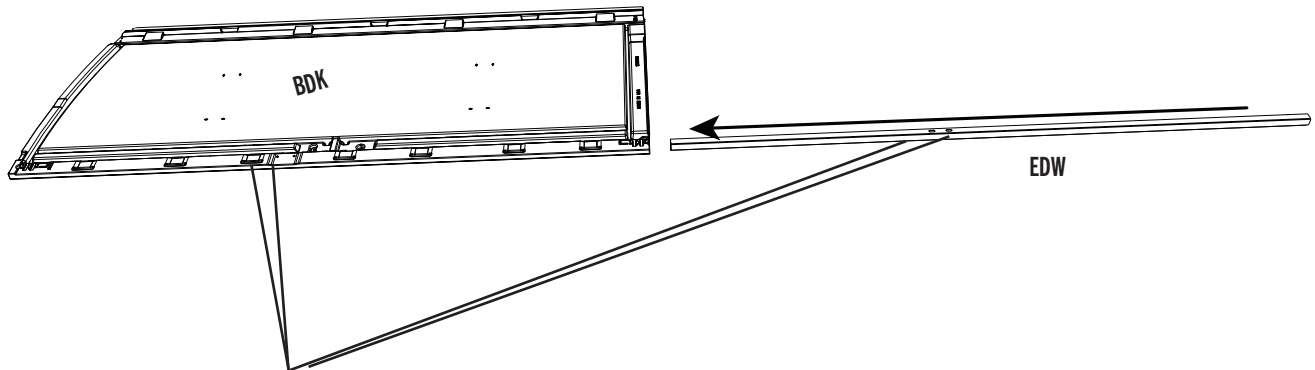

- *Align these holes in the next step*
- *Aligner ces trous à l'étape suivante*
- *Alinear estos agujeros en el paso siguiente*

### 5.2

- Insert an **end cap (BBH)** into the end of the tube, and finish inserting the tube until flush with bottom of door. Then, use a drill to insert a **self-drilling screw (CHK)** to hold it in place.
- Insérer un **capuchon (BBH)** dans l'extrémité du tube, et terminer d'insérer le tube jusqu'à ce qu'il soit à ras au bord inférieur de la porte. Puis, utiliser une perceuse pour insérer une **vis autotaraudeuse (CHK)** pour la maintenir en place.
- Insertar un **tapon (BBH)** en el extremo del tubo, y terminar de insertar el tubo hasta se alinee con la parte inferior de la puerta. Después, usar un taladro eléctrico para insertar un **tornillo auto-perforante (CHK)** para mantenerlo en su lugar.

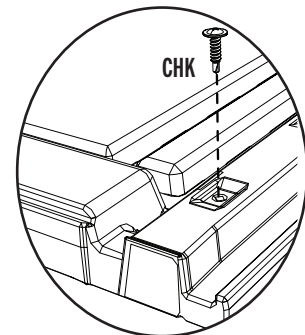
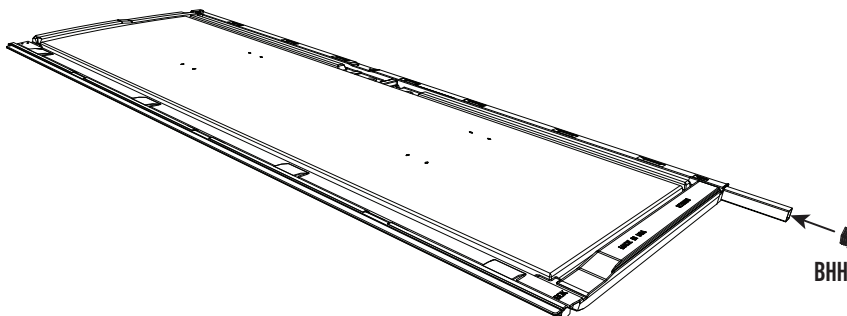

## ► SECTION 5 (CONTINUED) / SECTION 5 (SUITE) / SECCIÓN 5 (CONTINUACIÓN)

TOOLS AND HARDWARE REQUIRED / OUTILS ET QUINCAILLERIE REQUIS / INSTRUMENTAL Y HERRAJE REQUERIDOS



7/16 in/po  
(≈11 mm)



3/8 in/po  
(≈10 mm)

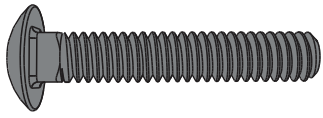

ACH (x2)

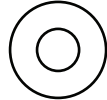

AEE (x2)

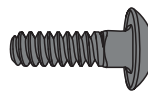

EPC (x2)



AEB (x2)

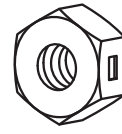

AAB (x2)



CXK (x2)

### 5.3

- Ensure the tube inside the door is flush with the bottom of the door. Attach the latch as shown.
- Veiller à ce que le tube dans la porte soit à ras au bord inférieur de la porte. Attacher le loquet comme indiqué.
- Asegurarse de que el tubo dentro de la puerta esté a ras del borde inferior de la puerta. Entonces, sujetar bien el pestajo como se muestra.

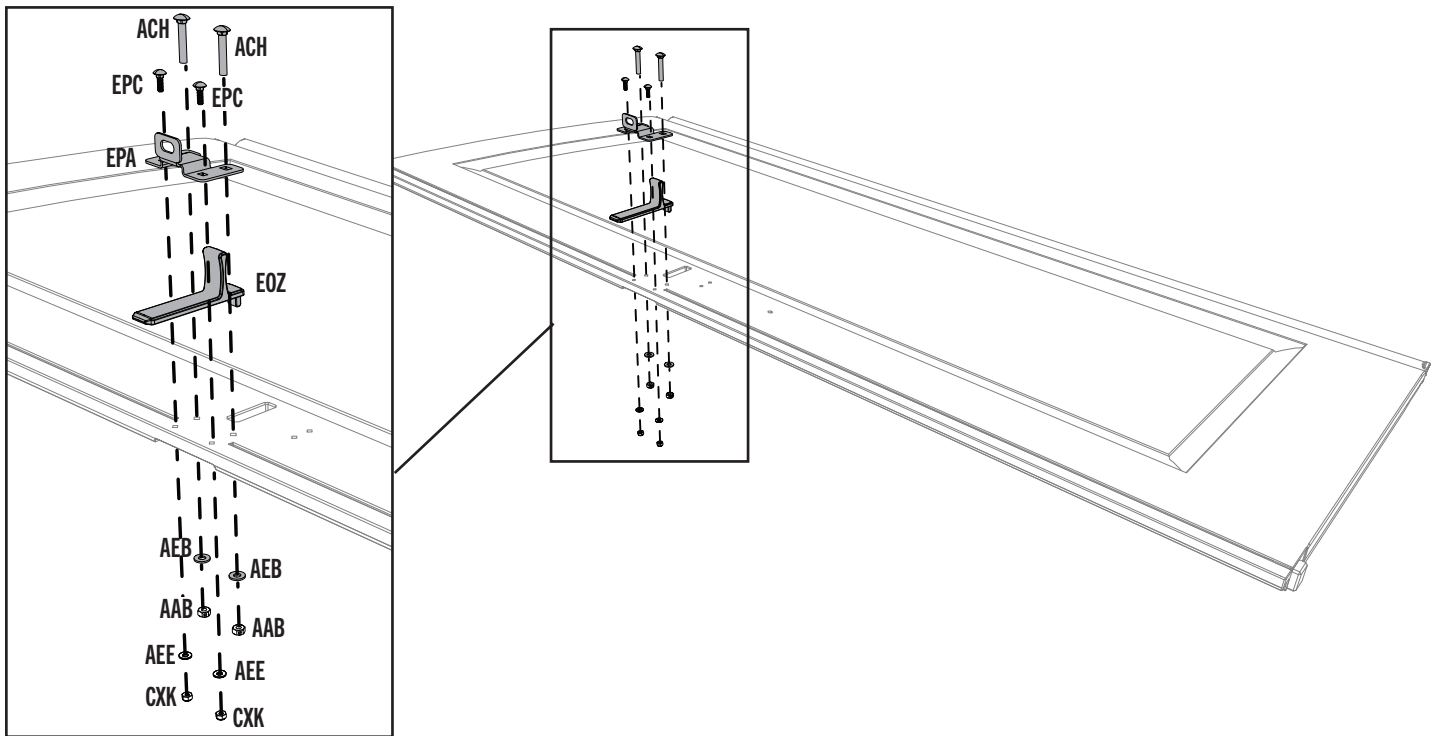

### 5.4

- Attach the two **handle pieces (BYR & BYS)** together as shown.
- Attacher les deux pièces de la **poignée (BYR et BYS)** comme indiqué.
- Conectar las dos piezas del **picaporte (BYR y BYS)** como se muestra.

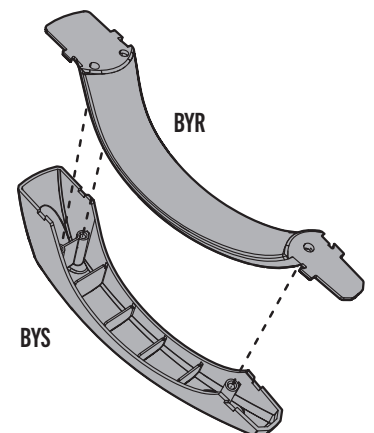

## ► SECTION 5 (CONTINUED) / SECTION 5 (SUITE) / SECCIÓN 5 (CONTINUACIÓN)

TOOLS AND HARDWARE REQUIRED / OUTILS ET QUINCAILLERIE REQUIS / INSTRUMENTAL Y HERRAJE REQUERIDOS

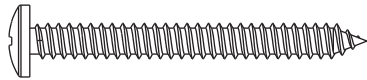

BYZ (x2)



ADW (x1)

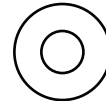

AEE (x1)

### 5.5

- Attach the handle as shown. **Tighten securely.**
- Bien attacher la poignée comme indiqué. **Bien serrer la quincaillerie.**
- Sujetar bien el picoporte como se muestra. **Apretar bien el herraje.**

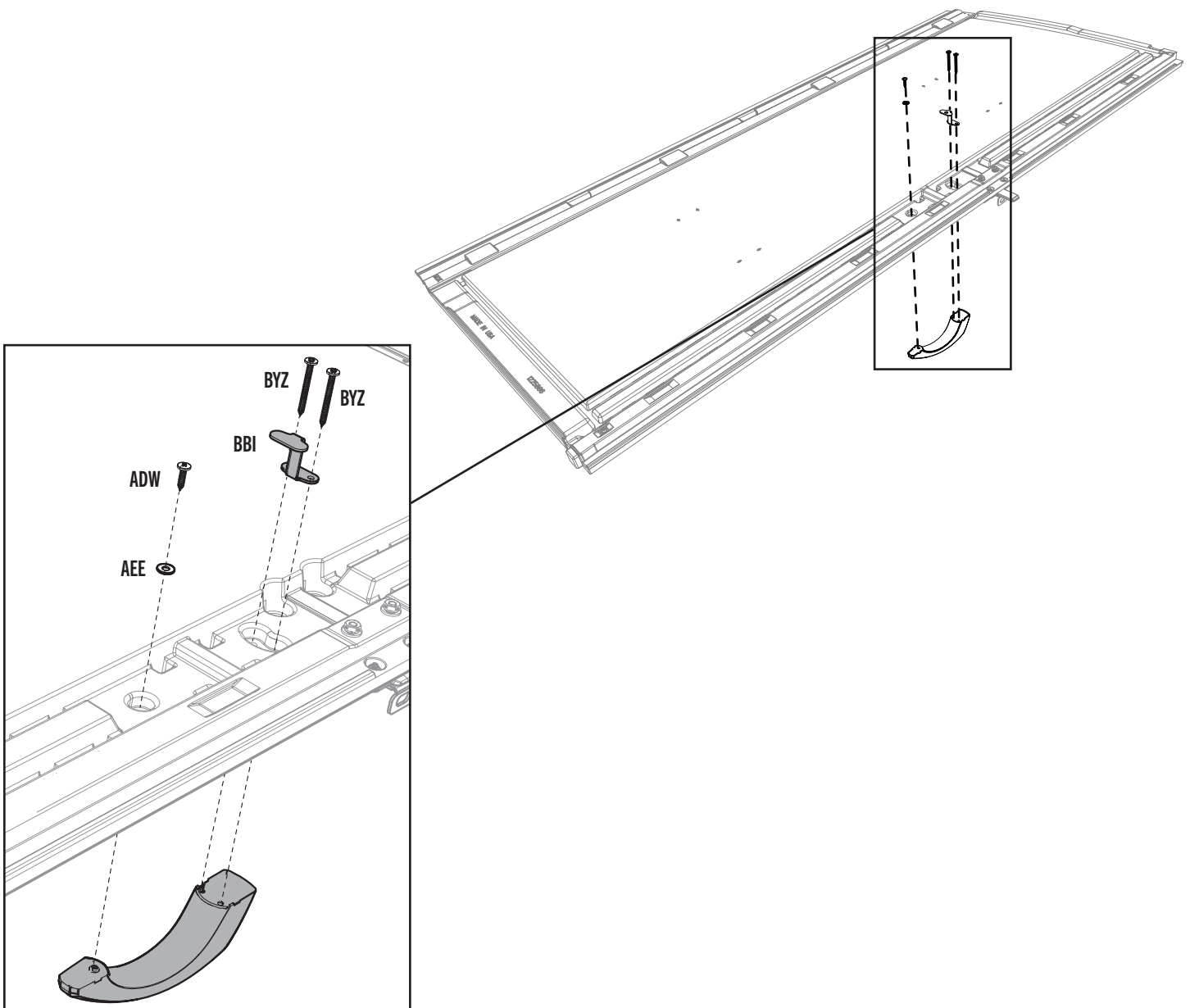



## ► SECTION 5 (CONTINUED) / SECTION 5 (SUITE) / SECCIÓN 5 (CONTINUACIÓN)

TOOLS AND HARDWARE REQUIRED / OUTILS ET QUINCAILLERIE REQUIS / INSTRUMENTAL Y HERRAJE REQUERIDOS



### 5.6

- Slide a **hinge tube (CRE)** into the hole in the door until a few inches remain out of the bottom.
- Faire glisser le **tube de articulation (CRE)** à travers le trou de la porte jusqu'à ce qu'il dépasse de quelques centimètres de la partie inférieure de la porte.
- Deslizar un **tubo de articulación (CRE)** adentro del agujero en la puerta hasta que el tubo cuelgue unas pulgadas de la parte inferior de la puerta.

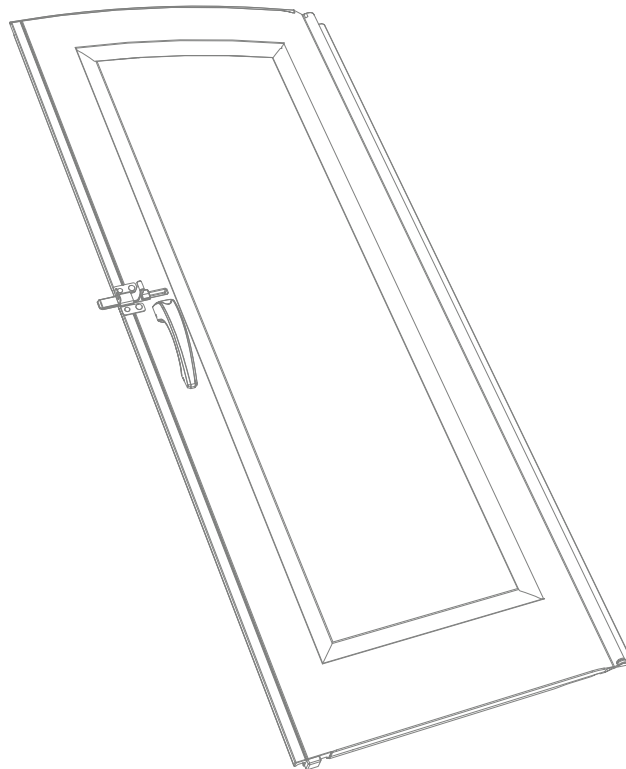
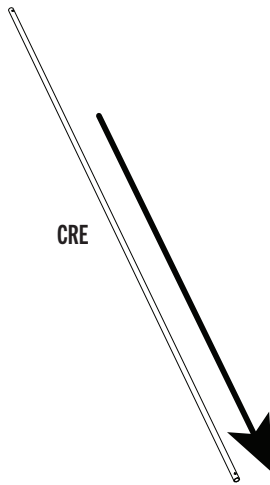

# 6

## FLOOR ASSEMBLY / ASSEMBLAGE DU PLANCHER / ENSAMBLAJE DEL PISO



### HARDWARE REQUIRED / QUINCAILLERIE REQUISE / HERRAJE REQUERIDO

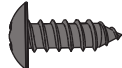

CWU (x32)\*

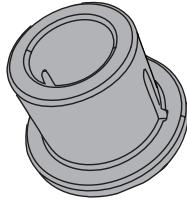

AHO (x2)



ADC (x1)

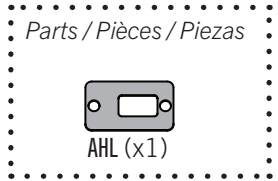

Parts / Pièces / Piezas



AHL (x1)



- These screws do not anchor the floor; they only hold the panels together.
- Ces vis n'ancrent pas le plancher; ils ne servent que pour attacher les panneaux les uns avec les autres.
- Estos tornillos no anclan el piso; sirven sólo para sujetar los paneles los unos con los otros.

- \* Not all hardware will be used in the section.
- \* La quincaillerie n'est pas utilisée au complet dans la section.
- \* No se utilizará todo el herraje en la sección.



### PARTS REQUIRED / PIÈCES REQUISES / PIEZAS REQUERIDAS

Plastic parts / Pièces en plastique / Piezas de plástico

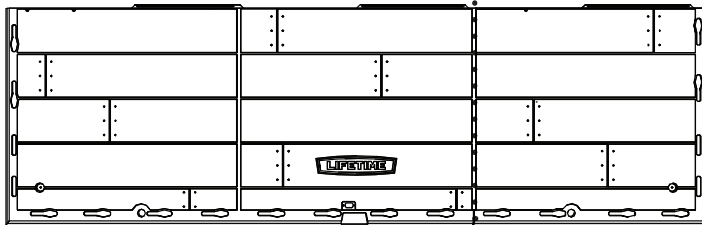

CUW (x2)

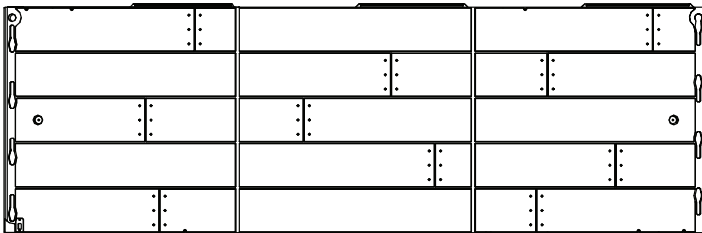

CUD (x2)

- Unfold the floor panels before installing.
- Dépliez les panneaux de sol avant l'installation.
- Despliegue los paneles del suelo antes de instalar.



### TOOLS REQUIRED / OUTILS REQUIS / INSTRUMENTAL REQUERIDO

(Not included—unless otherwise indicated\*) / (Non inclus — sauf indication contraire\*) / (No incluido, salvo indicación contraria\*)



## ► SECTION 6 (CONTINUED) / SECTION 6 (SUITE) / SECCIÓN 6 (CONTINUACIÓN)

TOOLS AND HARDWARE REQUIRED / OUTILS ET QUINCAILLERIE REQUIS / INSTRUMENTAL Y HERRAJE REQUERIDOS



- In case of any trouble with this section, scan the QR code below to view a video on its assembly.
- En cas de problème avec cette section, scanner le QR code en dessous pour voir une vidéo de l'assemblage.
- En caso de problemas con esta sección, escanear el código QR debajo para ver un video del ensamblaje.



<http://go.lifetime.com/10x8-section6>

### 6.1



- Hold an inner floor panel (CUD) at an angle and slide the tabs along the edge underneath an outer floor panel (CUW). The tabs interlock. Lay panel down flat.
- Posez un panneau de plancher intérieur (CUD) à un angle et glissez les languettes le long du bord au-dessus du panneau de plancher extérieur (CUW). Les languettes s'enclenchent les uns les autres. Étendez-le par terre.
- Coloque un panel de piso interior (CUD) a un ángulo y deslice las lengüetas a lo largo del borde debajo el panel de piso exterior (CUW). Las lengüetas se entrelazan las unas con las otras. Aplánelo.

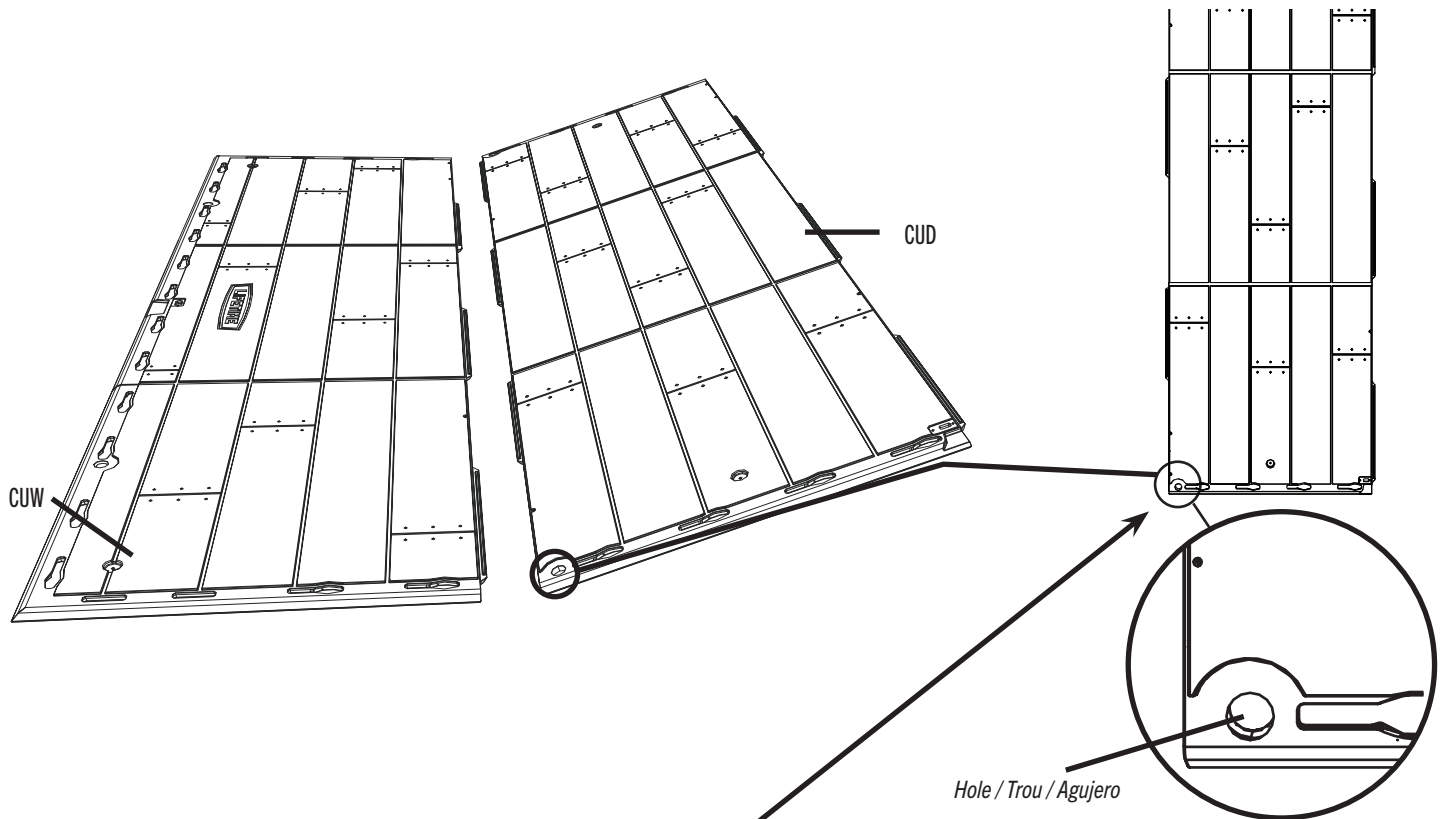

- If the hole is not at this corner, turn the Panel 180°.
- Si le trou n'est pas ici, tournez le panneau 180°.
- Si el agujero no está aquí, gire el panel 180°.

## ► SECTION 6 (CONTINUED) / SECTION 6 (SUITE) / SECCIÓN 6 (CONTINUACIÓN)

TOOLS AND HARDWARE REQUIRED / OUTILS ET QUINCAILLERIE REQUIS / INSTRUMENTAL Y HERRAJE REQUERIDOS



### 6.2

- Repeat the previous step.
- Répétez l'étape précédente.
- Repita el paso anterior.

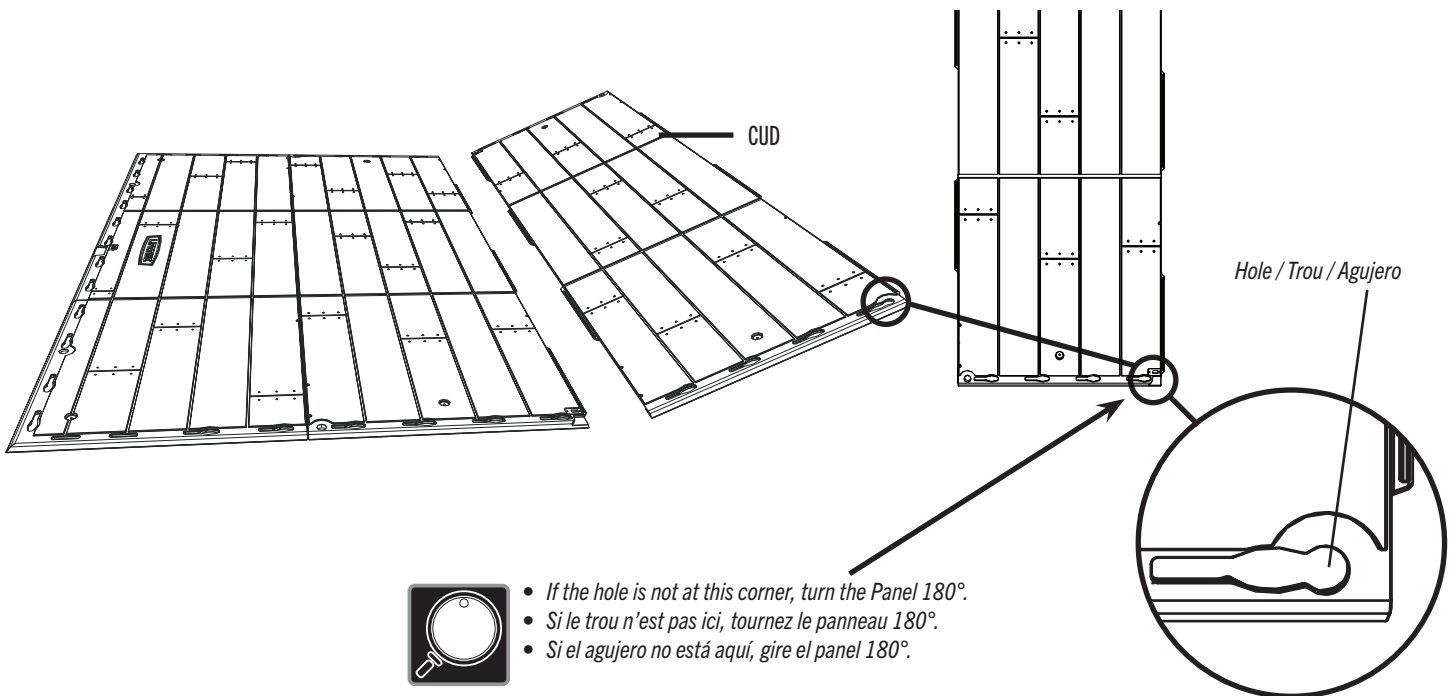

### 6.3

- Attach an outer floor panel (CUW) to the inner floor panel.
- Attachez un autre panneau de plancher intérieur (CUW) au panneau de plancher intérieur.
- Fije otro panel de piso exterior (CUW) al panel de piso interior.

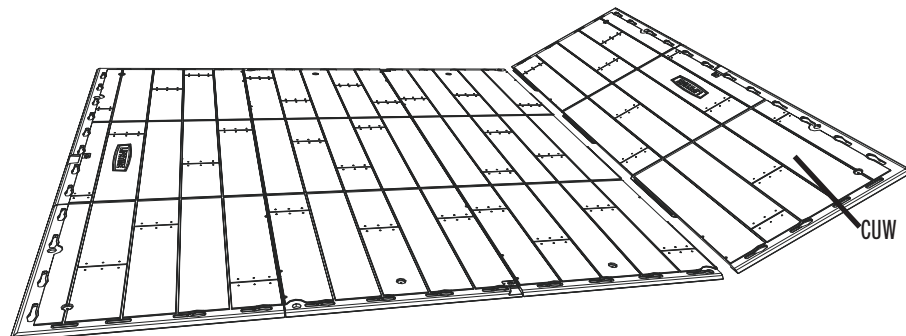

## ► SECTION 6 (CONTINUED) / SECTION 6 (SUITE) / SECCIÓN 6 (CONTINUACIÓN)

TOOLS AND HARDWARE REQUIRED / OUTILS ET QUINCAILLERIE REQUIS / INSTRUMENTAL Y HERRAJE REQUERIDOS

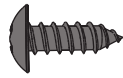

CWU (x18)

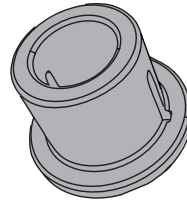

AHO (x2)

### 6.4

- Decide on which edge you would like to install your doors. Insert **bushings (AHO)** through the holes in the floor.
- Choisissez l'extrémité où vous désiriez installer les portes. Insérez les **bagues (AHO)** à travers les trous dans le plancher.
- Decide en cual borde le gustaría instalar las puertas. Introduzca los **casquillos (AHO)** a través de los agujeros en el piso.

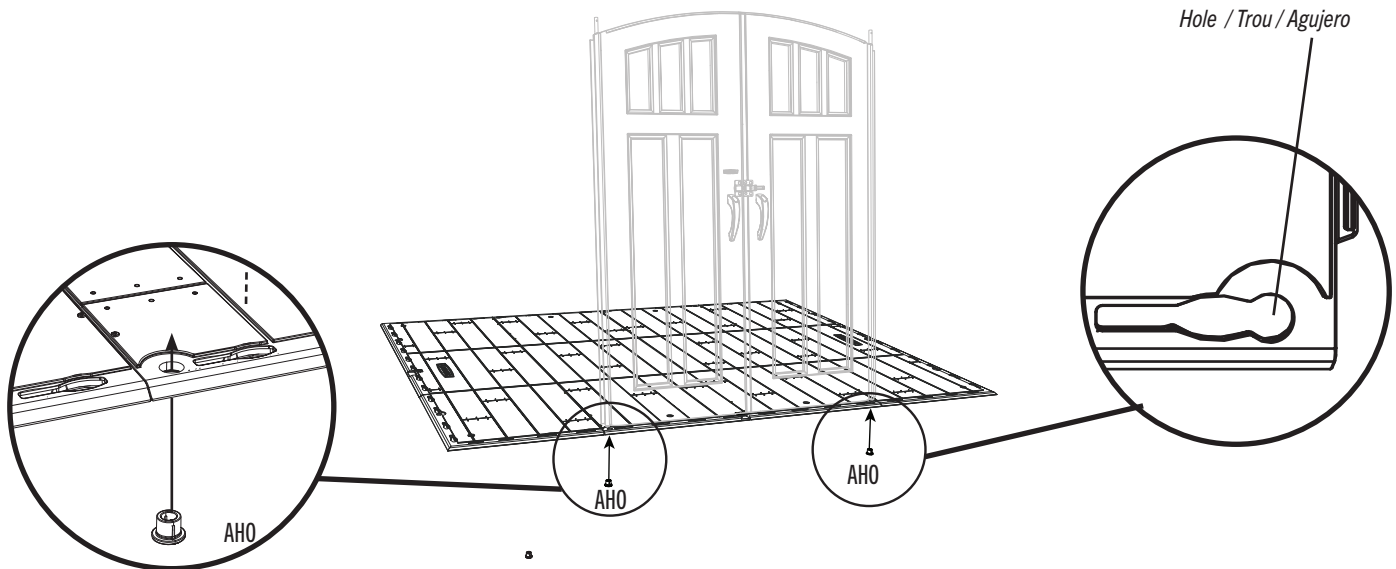

- *The slit in the bushing should face away from the floor.*
- *La fente dans la bague ne doit pas faire face au plancher.*
- *La rendija en el casquillo debe quedar en posición opuesta del piso.*

### 6.5

- Insert the **screws (CWU)** through the divots in the floor panels and into the tabs of the adjacent floor panels. (The divots are near the seams of the floor panels.)
- Insérez les **vis (CWU)** à travers les marques dans les panneaux de plancher et dans les languettes du panneaux de plancher contigu. (Les marques se trouvent près des jonctions des panneaux de plancher.)
- Introduzca los **tornillos (CWU)** a través de las marcas en los paneles de piso y dentro de las lengüetas des los paneles de piso adyacentes. (Se encuentran las marcas cerca de las juntas de los paneles de piso.)



- *These screws do not anchor the floor; they only hold the panels together.*
- *Ces vis n'ancrent pas le plancher; ils ne servent que pour attacher les panneaux les uns avec les autres.*
- *Estos tornillos no anclan el piso; sirven sólo para sujetar los paneles los unos con los otros.*

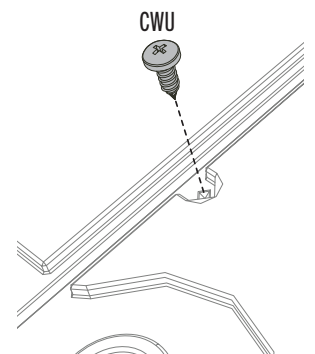
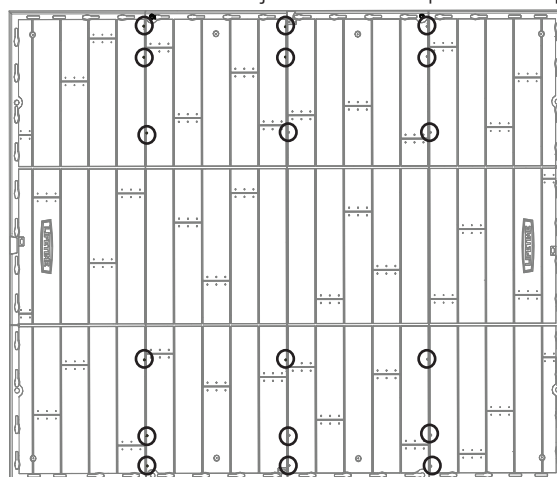

## ► SECTION 6 (CONTINUED) / SECTION 6 (SUITE) / SECCIÓN 6 (CONTINUACIÓN)

TOOLS AND HARDWARE REQUIRED / OUTILS ET QUINCAILLERIE REQUIS / INSTRUMENTAL Y HERRAJE REQUERIDOS

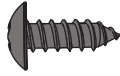

CWU (x2)



AHL (x1)

# 6.6

- Attach the strike plate (AHL) to the floor on the same side the bushings were installed.
- Attacher la gâche (AHL) au plancher sur le même côté que celui où les bagues ont été installées.
- Fijar la placa de impacto (AHL) al piso en el mismo lado donde se instalaron los casquillos.

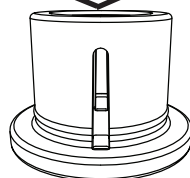
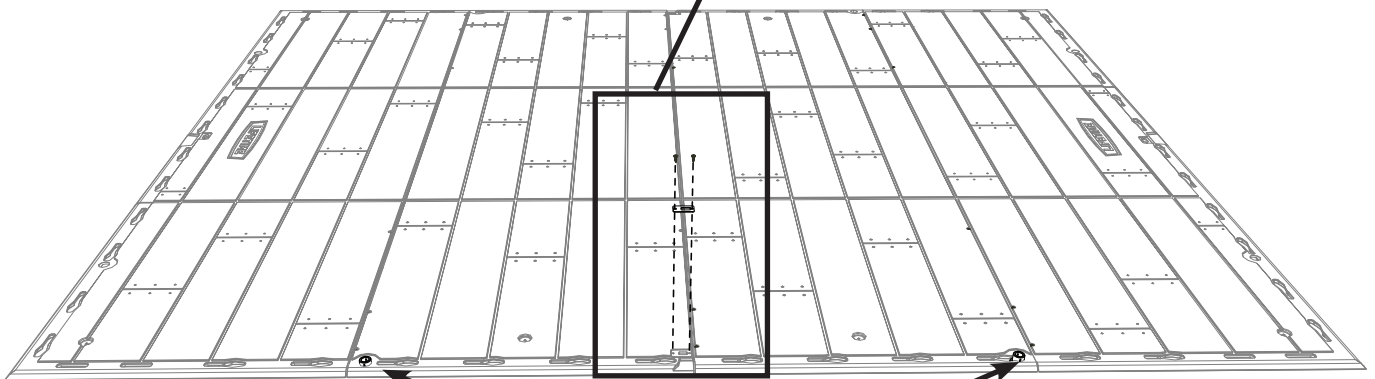
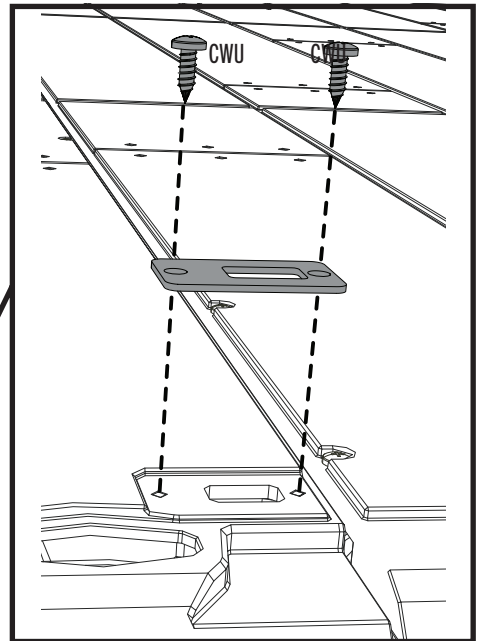

Bushings  
Bagues  
Casquillos

# 7

## WALL ASSEMBLY / ASSEMBLAGE DES MURS / ENSAMBLAJE DE LOS MUROS



### HARDWARE REQUIRED / QUINCAILLERIE REQUISE / HERRAJE REQUERIDO

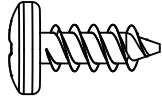

ADZ (x110)\*

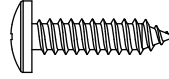

ADW (x28)

\* Not all hardware will be used in the section.  
 \* La quincaillerie n'est pas utilisée au complet dans la section.  
 \* No se utilizará todo el herraje en la sección.



### PARTS REQUIRED / PIÈCES REQUISES / PIEZAS REQUERIDAS

Metal parts / Pièces en métal / Piezas de metal

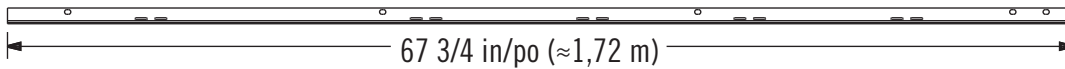

AFM (x5)

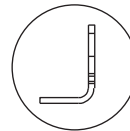

Plastic parts / Pièces en plastique / Piezas de plástico

Retirar el protector de plástico de las dos caras de una hoja (DHN).

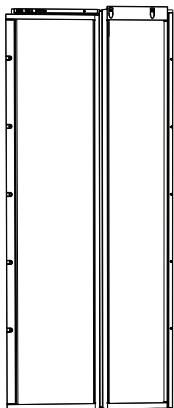

AGW (x2)

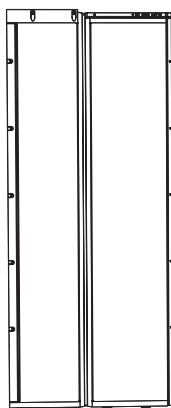

AGL (x2)

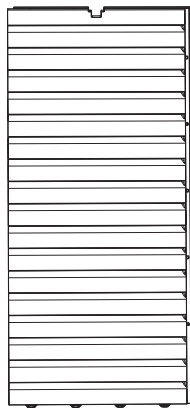

AHD (x7)



BDH (x1)

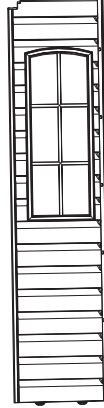

BDI (x1)



BDV (x2)

Parts / Pièces / Piezas

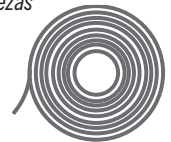

EPI (x2)

Parts / Pièces / Piezas



AIW (x1)



### TOOLS REQUIRED / OUTILS REQUIS / INSTRUMENTAL REQUERIDO

(Not included—unless otherwise indicated\*) / (Non inclus — sauf indication contraire\*) / (No incluido, salvo indicación contraria\*)

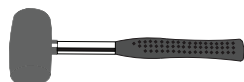

## ► SECTION 7 (CONTINUED) / SECTION 7 (SUITE) / SECCIÓN 7 (CONTINUACIÓN)

TOOLS AND HARDWARE REQUIRED / OUTILS ET QUINCAILLERIE REQUIS / INSTRUMENTAL Y HERRAJE REQUERIDOS



- In case of any trouble with this section, scan the QR code below to view a video on its assembly.
- En cas de problème avec cette section, scanner le QR code en dessous pour voir une vidéo de l'assemblage.
- En caso de problemas con esta sección, escanear el código QR debajo para ver un video del ensamblaje.



<http://go.lifetime.com/10x8-section7>

### 7.1

- There is a narrow groove (illustrated in black) running along the outside of the window on the back of each **narrow window wall panel (BDH & BDI)**. Starting at the top, left corner of the groove in one of the narrow window wall panels, lay a 1/8 in (3,2 mm) strip of the **tan butyl tape (EPH)** into the groove. **Do not worry about getting the strip completely into the groove just yet—simply lay the strip over the groove. Do not press the strip into the groove.** Work your way downward (1), and curve to go along the bottom (2) of the window. Curve your way upward (3) and then along the top (4) of the window until you're back where you started. **Clip off the excess.**
- Une rainure étroite (illustrée en noir) se trouve le long de l'extérieur de la fenêtre à l'arrière de chaque panneau mural étroit. Partant du coin supérieur gauche de la rainure dans un panneau mural étroit avec fenêtre, étendez une goutte de 1/8 po (3,2 mm) de **ruban de caoutchouc butyl couleur sable (EPH)** dans la rainure. **Ne vous inquiétez pas si la goutte n'est pas complètement dans la rainure en ce moment, ne faites que déposer la goutte sur la rainure.** Ne poussez pas la goutte dans la rainure. Travaillez vers le bas (1), et courbez pour atteindre le bas (2) de la fenêtre. Courbez vers le haut (3), puis le long du haut (4) de la fenêtre jusqu'à ce que vous reveniez au point de départ. **Coupez l'excédent.**
- Hay una ranura angosta (ilustrada en negro) bordeando la ventana en la superficie posterior de cada panel mural angosto con ventana. Comenzando desde arriba, en la esquina izquierda de la ranura en un panel, aplique una línea de 1/8 in (3,2 mm) de **cinta butilica de color cuero (EPH)** en la ranura. **Ne se preocupe por poner la cinta, mas solamente ponga la cinta sobre la ranura. No presione la cinta dentro de la ranura.** Siga hacia abajo (1), y curvéela a lo largo del borde inferior (2) de la ventana. Curvéela hacia arriba (3) y, entonces, a lo largo del borde superior (4) de la ventana hasta estar al punto de partida. **Corte el exceso.**

Groove / Rainure / Ranura

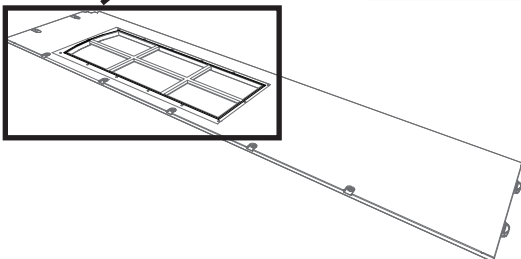
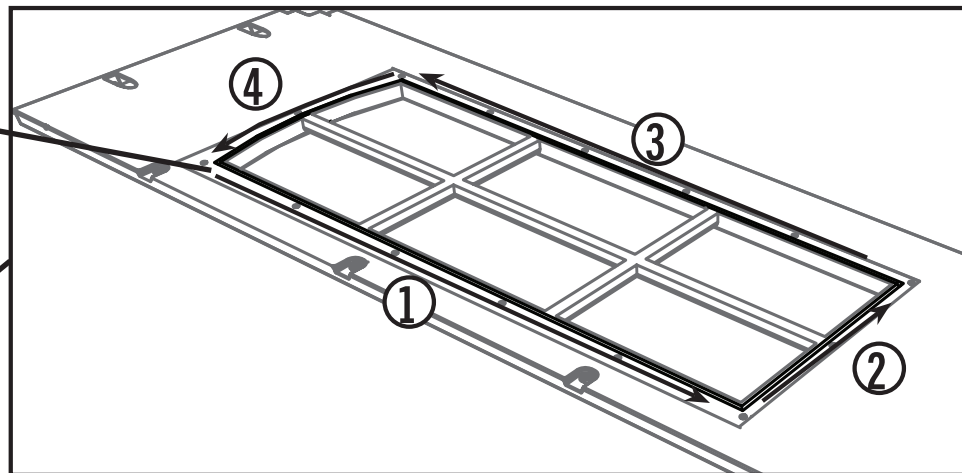

EPI (x2)



## ► SECTION 7 (CONTINUED) / SECTION 7 (SUITE) / SECCIÓN 7 (CONTINUACIÓN)

TOOLS AND HARDWARE REQUIRED / OUTILS ET QUINCAILLERIE REQUIS / INSTRUMENTAL Y HERRAJE REQUERIDOS

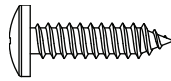

ADW (x28)

### 7.2



- Peel off the protective backing from both sides of **window pane (BDV)**. Align the holes in the pane with those in the panel, and gently set a window pane down onto the panel. Secure the pane to the panel using fourteen (14) **screws (ADW)**. Repeat steps 7.1–7.2 for the second narrow window wall panel.
- Retirez la pellicule protectrice des deux côtés du **carreau (BDV)**. Alignez les trous dans le carreau avec ceux de la porte, et, avec douceur, mettez le carreau sur la porte. Fixez le carreau à la porte en utilisant quatorze (14) **vis (ADW)**. Répétez les étapes 7.1 – 7.2 pour le deuxième panneau mural étroit avec fenêtre.
- Retire el protector de plástico de las dos caras de una **hoja (BDV)**. Alinee los agujeros en la hoja con los de la puerta, y coloque ligeramente la hoja de ventana en la puerta. Sujete la hoja a la puerta usando catorce (14)  **tornillos (ADW)**. Repita los pasos 7.1–7.2 para la segunda Panel mural angosto con ventana.

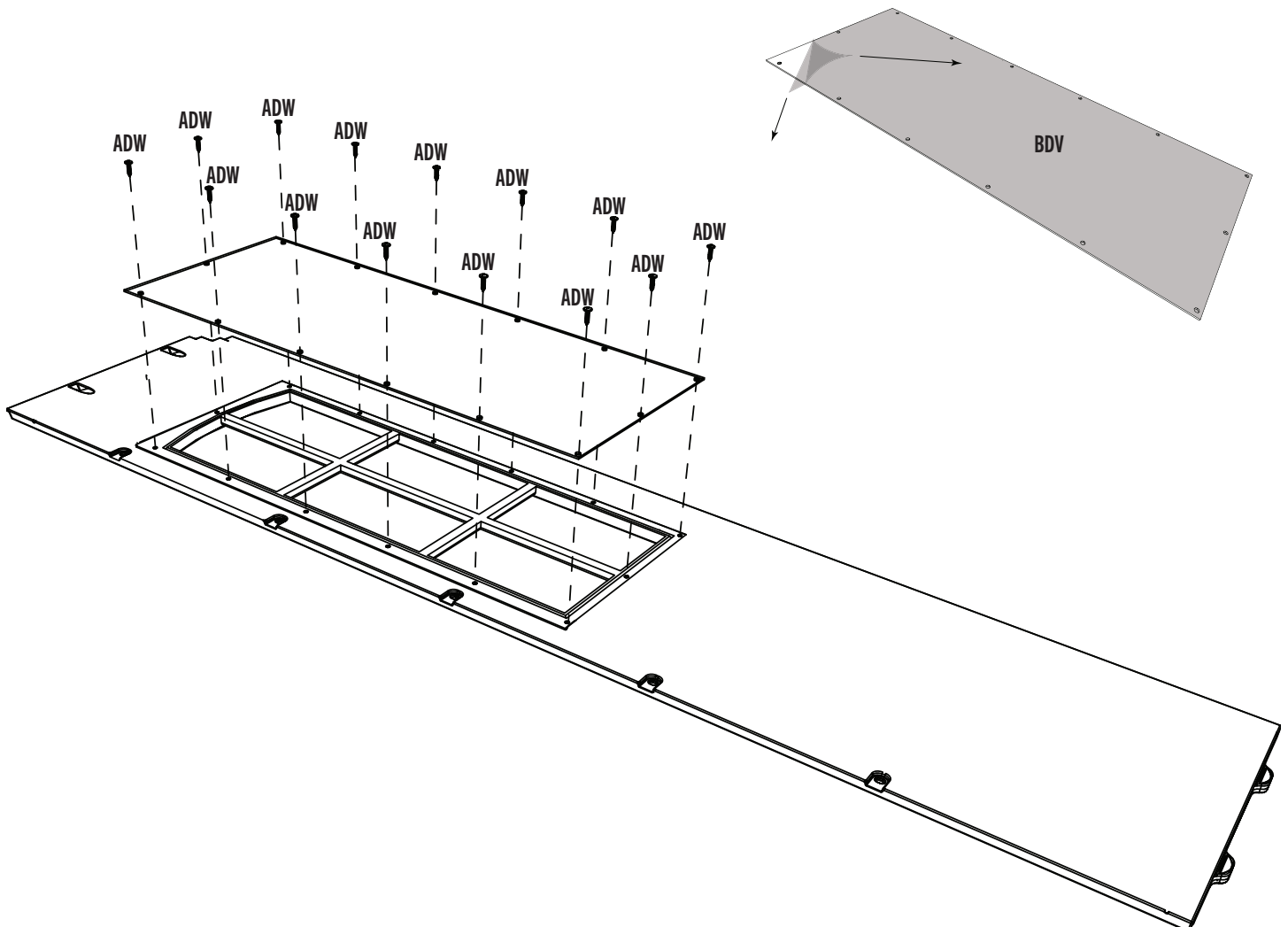

## SECTION 7 (CONTINUED) / SECTION 7 (SUITE) / SECCIÓN 7 (CONTINUACIÓN)

TOOLS AND HARDWARE REQUIRED / OUTILS ET QUINCAILLERIE REQUIS / INSTRUMENTAL Y HERRAJE REQUERIDOS

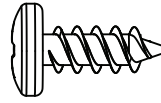

ADZ (x12)

### 7.3

- Top end
- Extrémité supérieure
- Extremo superior



- No screw in top hole.
- Aucune vis dans le trou supérieur.
- Ningún tornillo en el agujero superior.

- Secure a **wall support channel (AFM)** at the middle of the notch on three (3) back **wall panels (AHD)** using four (4) **screws (ADZ)** for each. The remaining wall panels will have the wall support channels installed in the next section.
- Fixez un **renfort de soutien mural (AFM)** au centre de l'encoche de chacun sur trois (3) **panneaux muraux arrière (AHD)** à l'aide de quatre (4) **vis (ADZ)**. Les autres panneaux muraux restants auront les chenaux de support muraux installés dans la section suivante.
- Asegure un **canal soporte de pared (AFM)** en el medio de la marca en tres (3) **paneles de pared trasera (AHD)** utilizando cuatro (4) **tornillos (ADZ)** para cada uno. Los canales de apoyo para la pared des paneles restantes se instalarán en la siguiente sección.

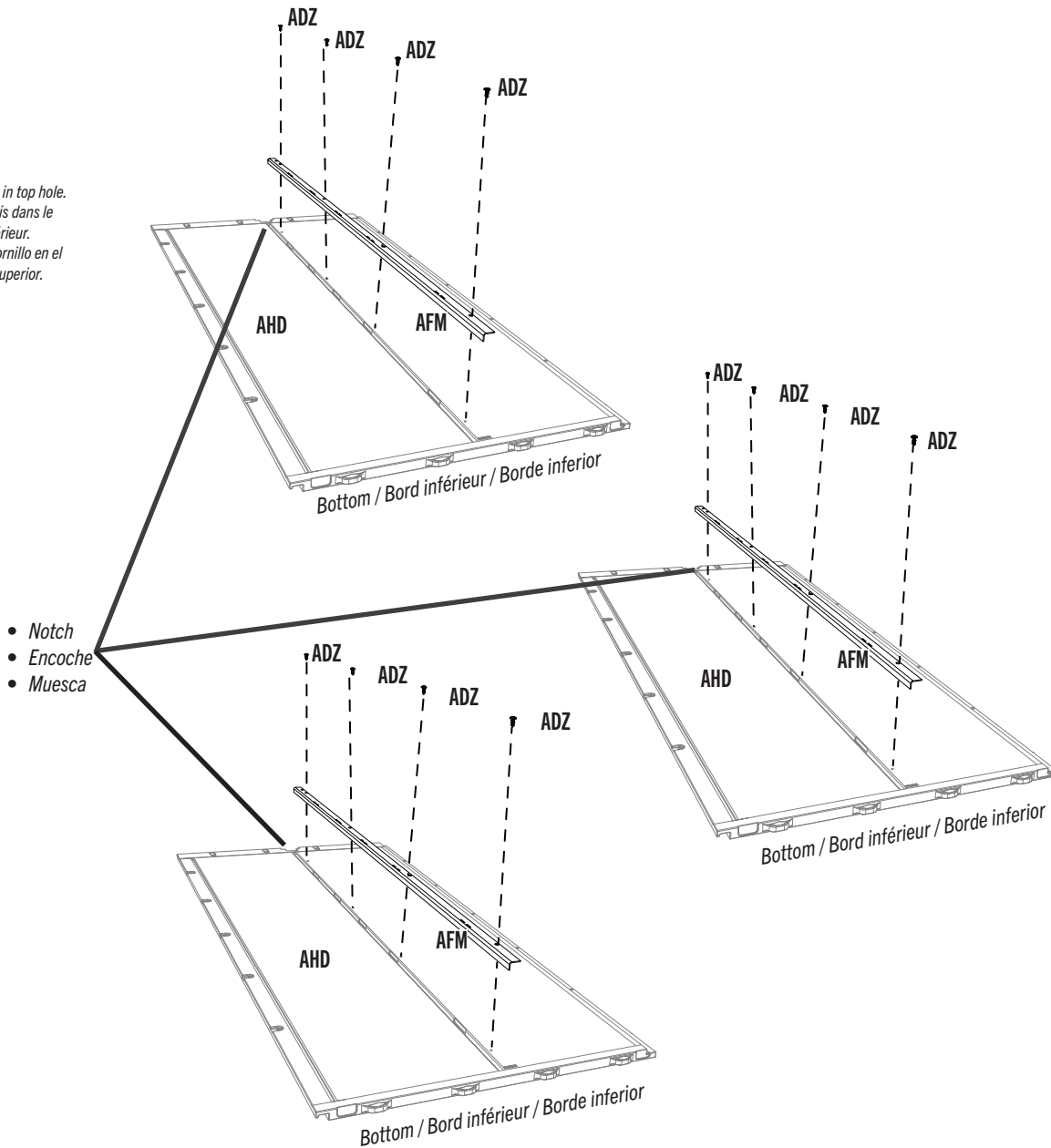

## ► SECTION 7 (CONTINUED) / SECTION 7 (SUITE) / SECCIÓN 7 (CONTINUACIÓN)

TOOLS AND HARDWARE REQUIRED / OUTILS ET QUINCAILLERIE REQUIS / INSTRUMENTAL Y HERRAJE REQUERIDOS



### 7.4



- Insert tabs at the bottom of the **right window wall panel (BDI)** into the third and fourth slots from the front, right corner of the floor.
- Insérez les languettes au bord inférieur du **panneau mural droit pour la fenêtre (BDI)** dans les troisième et quatrième rainures du coin droit du plancher.
- Introduzca las lengüetas al borde inferior del **panel mural derecho para la ventana (BDI)** en las tercera y quarta ranuras de la esquina derecha del piso.

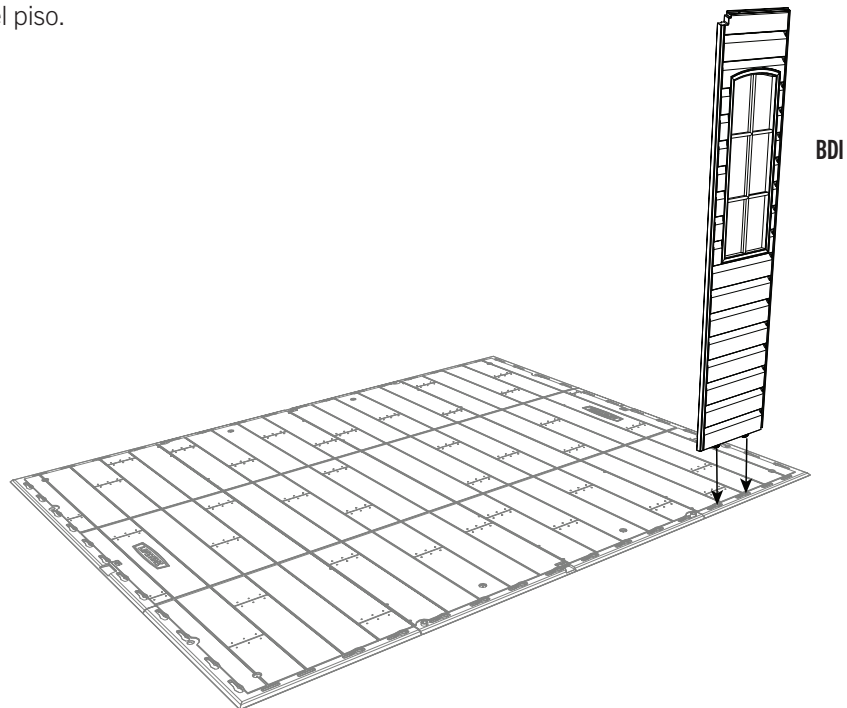

### 7.5

- Slide the panel to the left.
- Faites glisser le panneau à gauche.
- Deslice el panel a la izquierda.

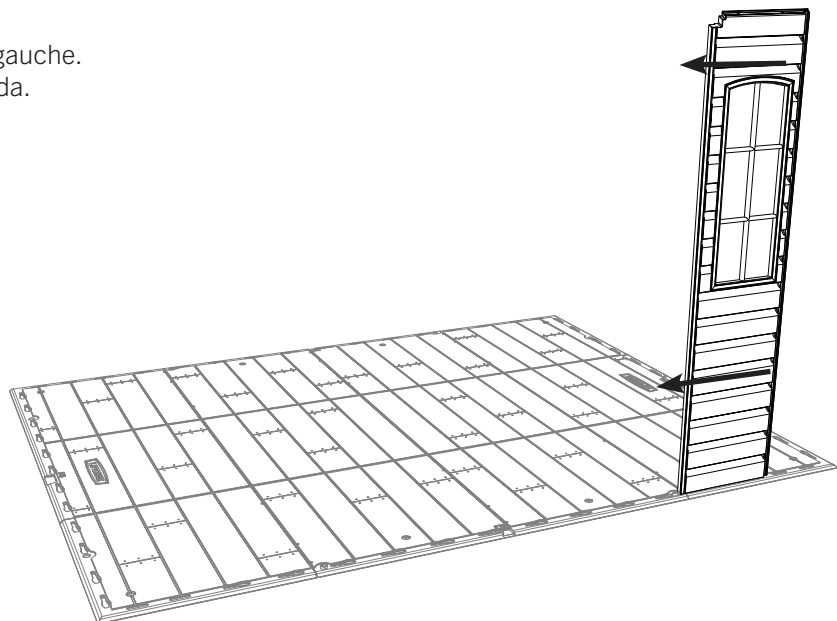

## ► SECTION 7 (CONTINUED) / SECTION 7 (SUITE) / SECCIÓN 7 (CONTINUACIÓN)

TOOLS AND HARDWARE REQUIRED / OUTILS ET QUINCAILLERIE REQUIS / INSTRUMENTAL Y HERRAJE REQUERIDOS

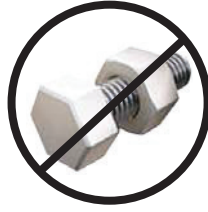

### 7.6

- Insert tabs at the bottom of the **corner panel (AGW)** into the first two slots along the right edge of the floor, and slide the panel toward the front of the floor.
- Insérez les languettes au bord inférieur du **panneau angulaire (AGW)** dans les premières rainures le long du bord droit du plancher, et faites glisser le panneau vers la partie avant de l'abri.
- Introduzca las lengüetas al borde inferior del **panel angular (AGW)** en las primeras dos ranuras a lo largo del borde derecho del piso, y deslice el panel hacia la parte delantera de la caseta.

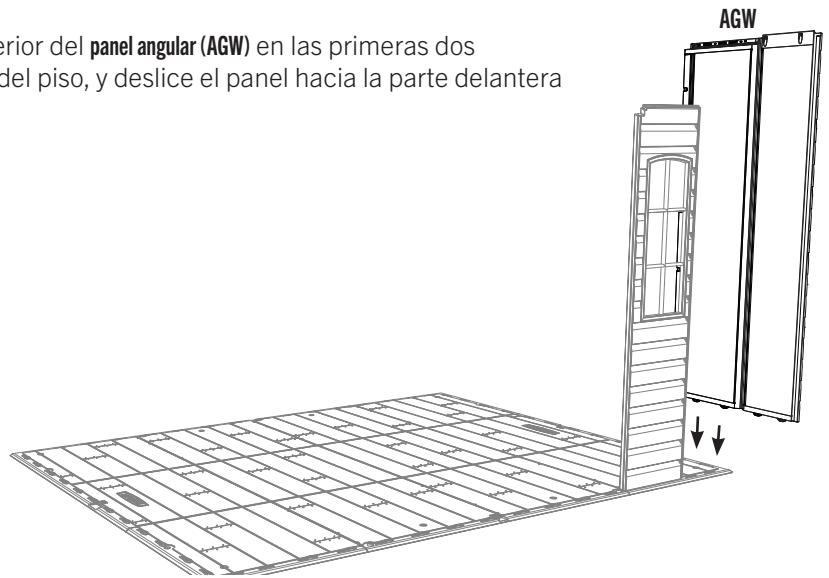

### 7.7

- Bend the corner panel as shown, and pull down to snap the tabs into the first two slots from the right corner of the floor. Place the **block (AIW)** underneath the floor and directly underneath the tab being inserted to help with insertion.
- Pliez le panneau angulaire comme indiqué, tirez le panneau vers le bas, et insérez les languettes dans les premières deux encoches du coin vant doir. Pour aider avec l'insertion, mettez le **bloc (AIW)** sous le plancher et directement sous l'onglet à insérer.
- Despliegue el panel angular como se muestra, tire para abajo el panel, e introduzca las lengüetas en las dos primeras muescas de la esquina delantera derecha. Para ayudar con la inserción, coloque el **bloque (AIW)** debajo el piso y directamente debajo la lengüeta a insertar.

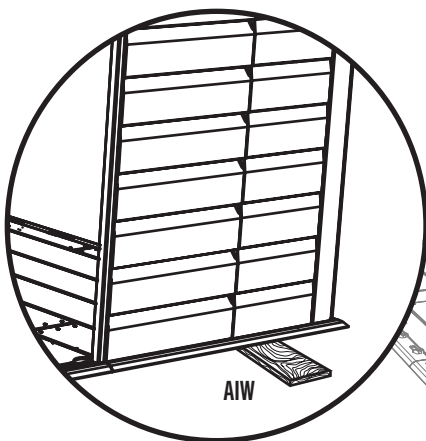

AIW (x1)

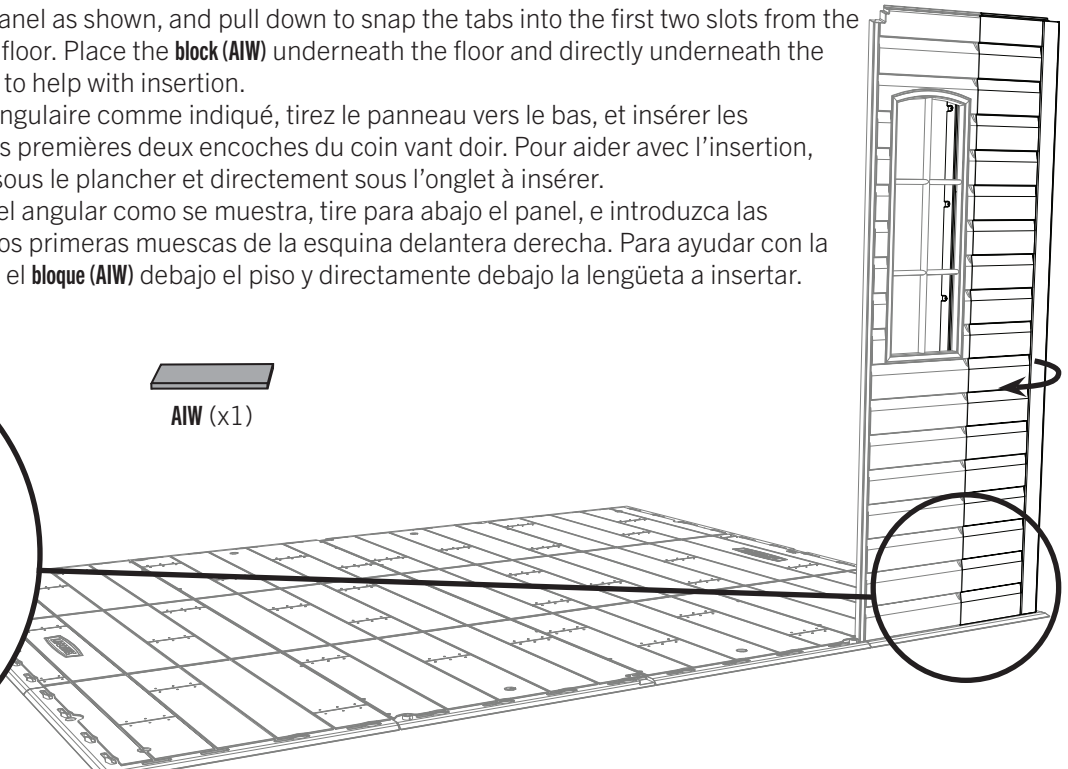



# PARTS IDENTIFIER / IDENTIFICATEUR DE PIÈCES / IDENTIFICADOR DE PIEZAS

CONTENTS OF BOX 1 / CONTENU DE LA BOÎTE 1 / CONTENIDO DE LA CAJA 1

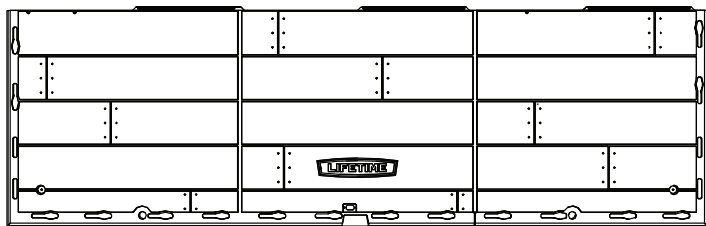

CUW (x2)

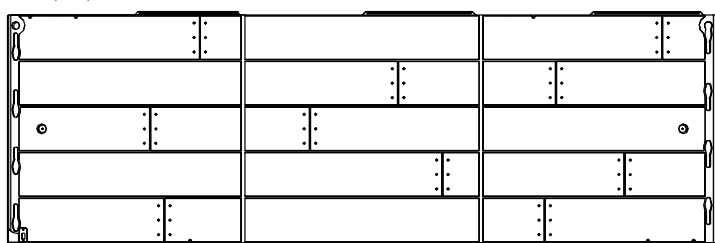

CUD (x2)

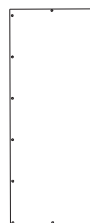

BDV (x2)

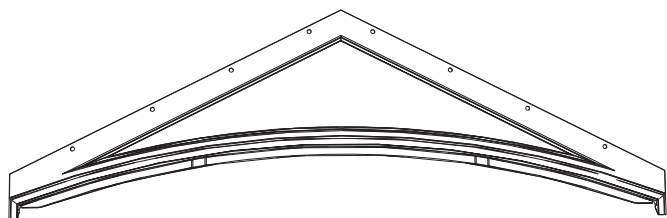

BDC (x1)

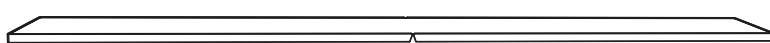

AFV (x2)

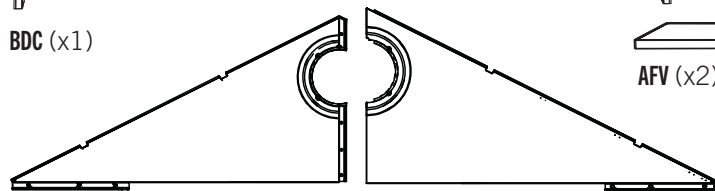

AGI (x2)

AGH (x2)

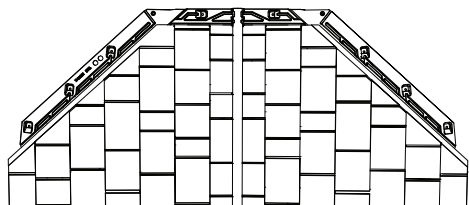

DRA (x1)

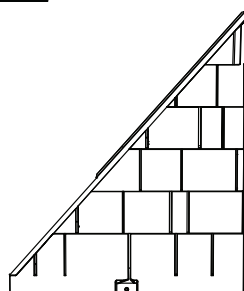

BDS (x1)

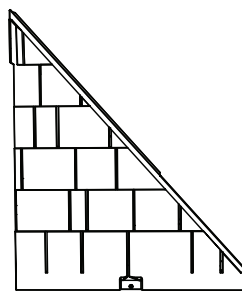

BDR (x1)

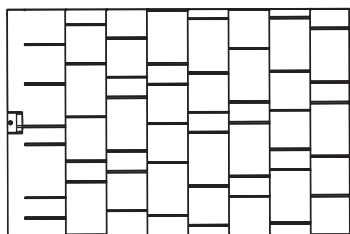

AGQ (x6)

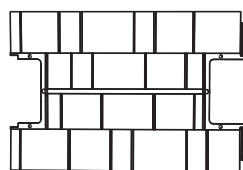

AFY (x3)

Remove this section for quick reference / Enlever cette section pour référence rapide / Retirar esta sección para referencia rápida



# PARTS IDENTIFIER / IDENTIFICATEUR DE PIÈCES / IDENTIFICADOR DE PIEZAS

METAL PARTS KIT 1 / KIT 1 PIÈCES EN MÉTAL / KIT 1 DE PIEZAS DE METAL



Remove this section for quick reference / Enlever cette section pour référence rapide / Retirar esta sección para referencia rápida

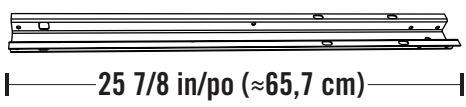
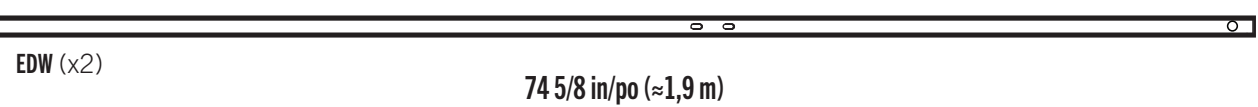
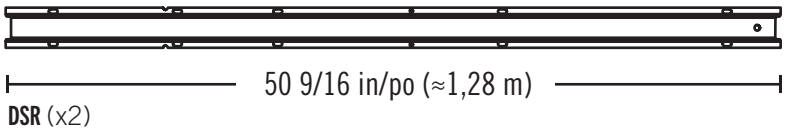
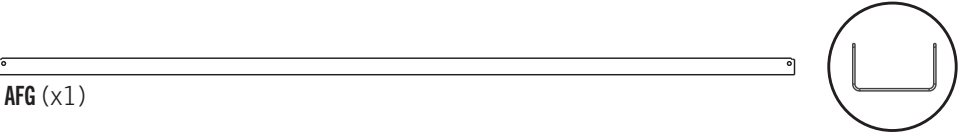
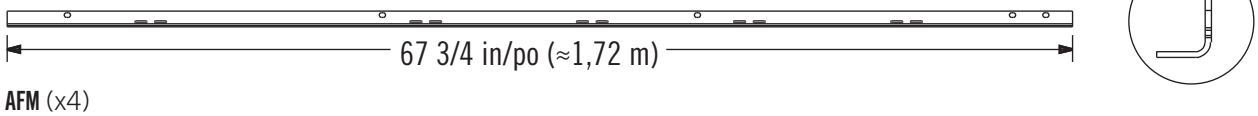
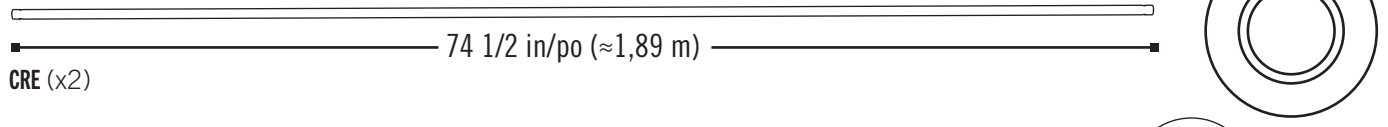

DSM (x1)  
 METAL PARTS KIT 2 / KIT 2 PIÈCES EN MÉTAL / KIT 2 DE PIEZAS DE METAL

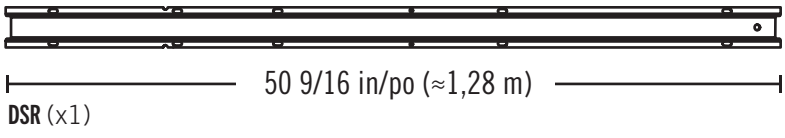
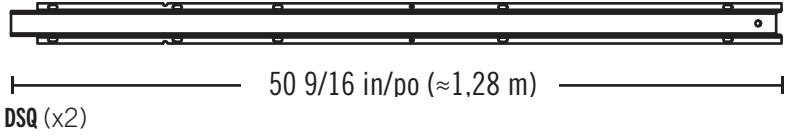
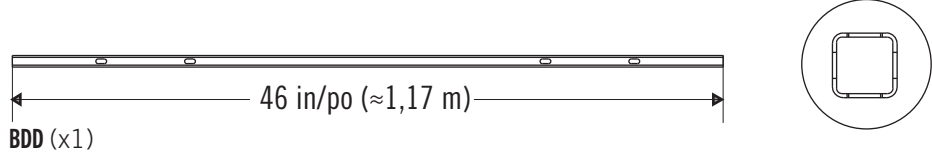
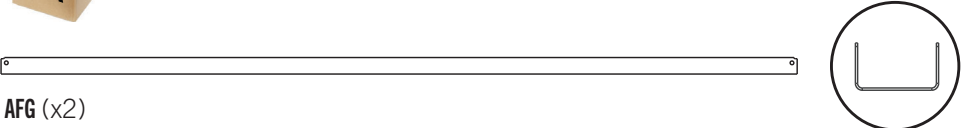



# PARTS IDENTIFIER / IDENTIFICATEUR DE PIÈCES / IDENTIFICADOR DE PIEZAS

METAL PARTS KIT 2 / KIT 2 PIÈCES EN MÉTAL / KIT 2 DE PIEZAS DE METAL

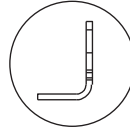
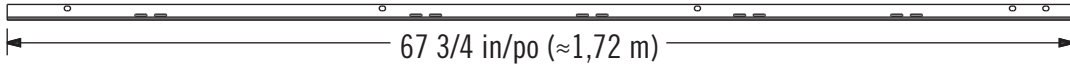

AFM (x5)

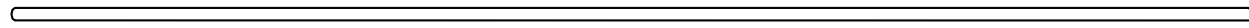

H DU (x2)

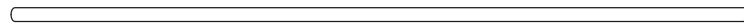

HDT (x2)



DSP (x1)

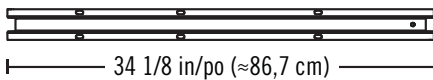

DSO (x1)

CONTENTS OF BOX 2 / CONTENU DE LA BOÎTE 2 / CONTENIDO DE LA CAJA 2

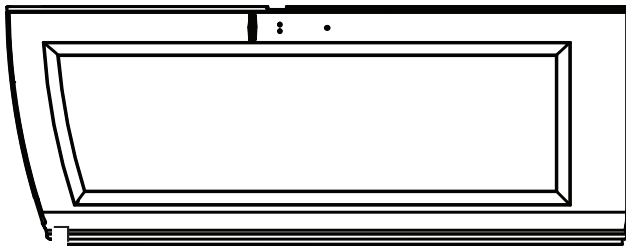

BDJ (x1)

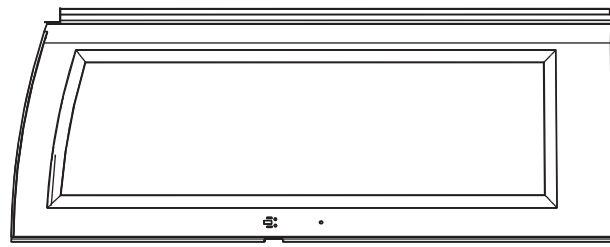

BDK (x1)

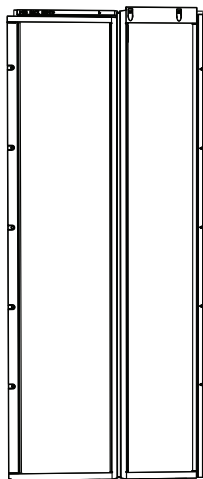

AGW (x2)

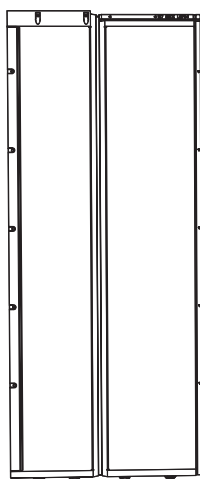

AGL (x2)

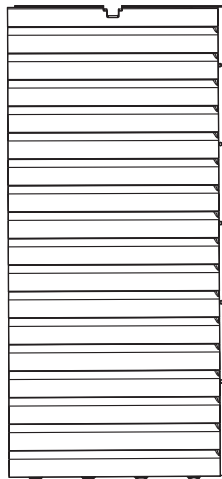

AHD (x7)

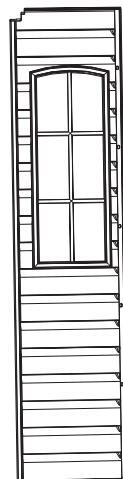

BDI (x1)

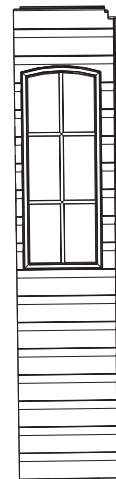

BDH (x1)

Remove this section for quick reference / Enlever cette section pour référence rapide / Retirar esta sección para referencia rápida



# PARTS IDENTIFIER / IDENTIFICATEUR DE PIÈCES / IDENTIFICADOR DE PIEZAS

CONTENTS OF BOX 2 / CONTENU DE LA BOÎTE 2 / CONTENIDO DE LA CAJA 2



CONTENTS OF SMALL PARTS BOX / CONTENU DE LA BOÎTE DE PETITES PIÈCES / CONTENIDO DE LA CAJA DE PIEZAS PEQUEÑAS

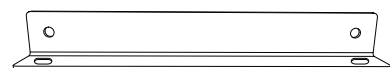

HDV (x4)

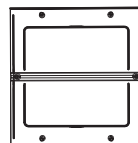

AHC (x4)

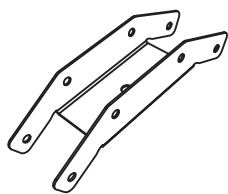

AIP (x3)

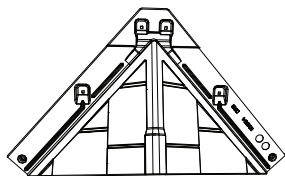

DRB (x1)

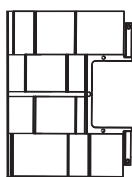

AGG (x1)

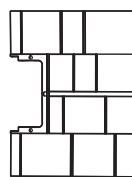

AFW (x1)



± 8 7/16 in/po (≈ 21,4 cm)±

DSN (x1)



AFL (x6)



AIW (x1)



EPI (x2)

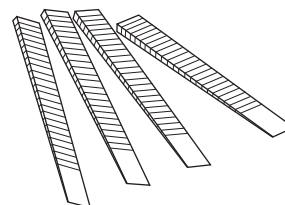

AIX (x4)

HARDWARE BAGS / SACS DE QUINCAILLERIE / BOLSAS DE HERRAJE

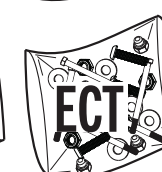
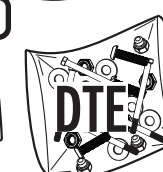

Remove this section for quick reference / Enlever cette section pour référence rapide / Retirar esta sección para referencia rápida



## ► SECTION 7 (CONTINUED) / SECTION 7 (SUITE) / SECCIÓN 7 (CONTINUACIÓN)

TOOLS AND HARDWARE REQUIRED / OUTILS ET QUINCAILLERIE REQUIS / INSTRUMENTAL Y HERRAJE REQUERIDOS

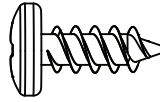

ADZ (x15)

### 7.8

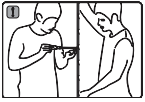

- Secure the two panels using five (5) screws (ADZ). Do not overtighten. The attachment points may have a thin membrane that the screws will puncture.
- Bien attachez les deux panneaux à l'aide de cinq (5) vis (ADZ). Ne pas serrer excessivement les vis. Les points de fixation peuvent avoir une fine membrane que les vis perceront.
- Sujete los dos paneles usando cinco (5) tornillos (ADZ). No apretar demasiado los tornillos. Los puntos de fijación pueden tener una membrana delgada que los tornillos perforarán.

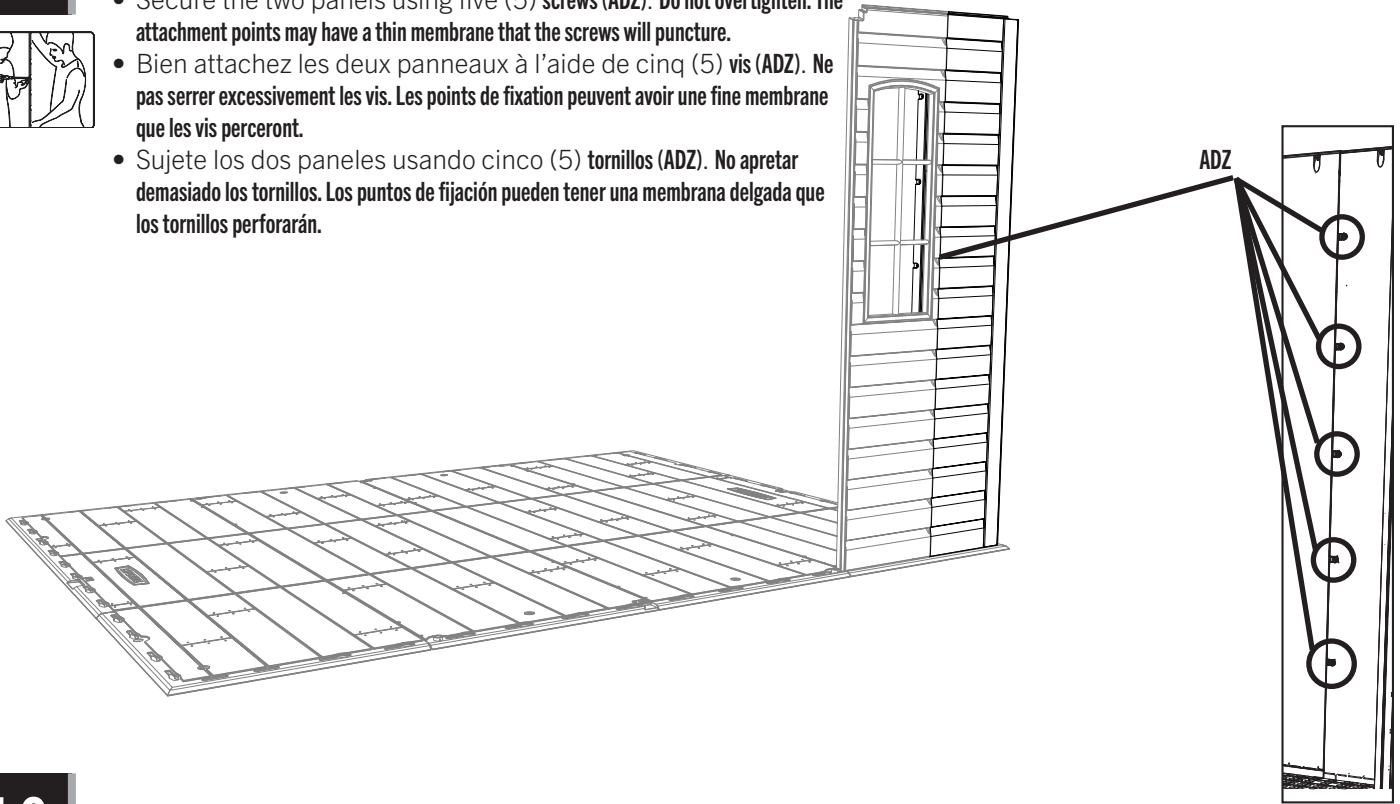

### 7.9

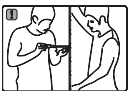

- Insert two (2) wall panels (AHD) and secure using five (5) screws (ADZ) each. Insert the two (2) wall panels (AHD) WITHOUT the wall support channels here.
- Insérez deux (2) panneaux muraux (AHD) et attachez-les l'un à l'autre à l'aide de cinq (5) vis (ADZ) chaque un. Insérer les deux (2) panneaux muraux (AHD) SANS les canaux de support mural ici.
- Inserte dos (2) paneles de pared (AHD) y sujételos usando cinco (5) tornillos (ADZ) cada uno. Insertar los dos (2) paneles murales (AHD) SIN los canales de soporte de muros aquí.

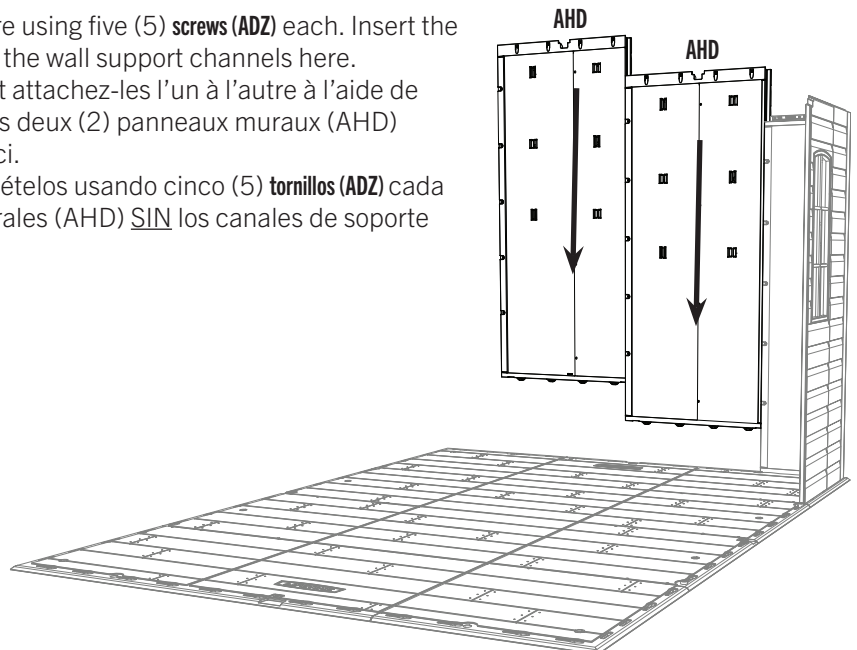

## SECTION 7 (CONTINUED) / SECTION 7 (SUITE) / SECCIÓN 7 (CONTINUACIÓN)

TOOLS AND HARDWARE REQUIRED / OUTILS ET QUINCAILLERIE REQUIS / INSTRUMENTAL Y HERRAJE REQUERIDOS

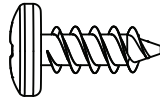
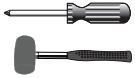

ADZ (x20)

### 7.10

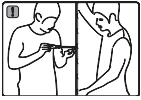

- For the right, rear **corner panel (AGL)**, repeat the step you did for the right, front corner panel.
- Pour le **panneau angulaire (AGL)** arrière droit, répétez les étapes réalisées pour le panneau angulaire avant droit.
- Para el **panel angular (AGL)** trasero derecho, repita los pasos que se efectuaron para el panel angular delantero derecho.

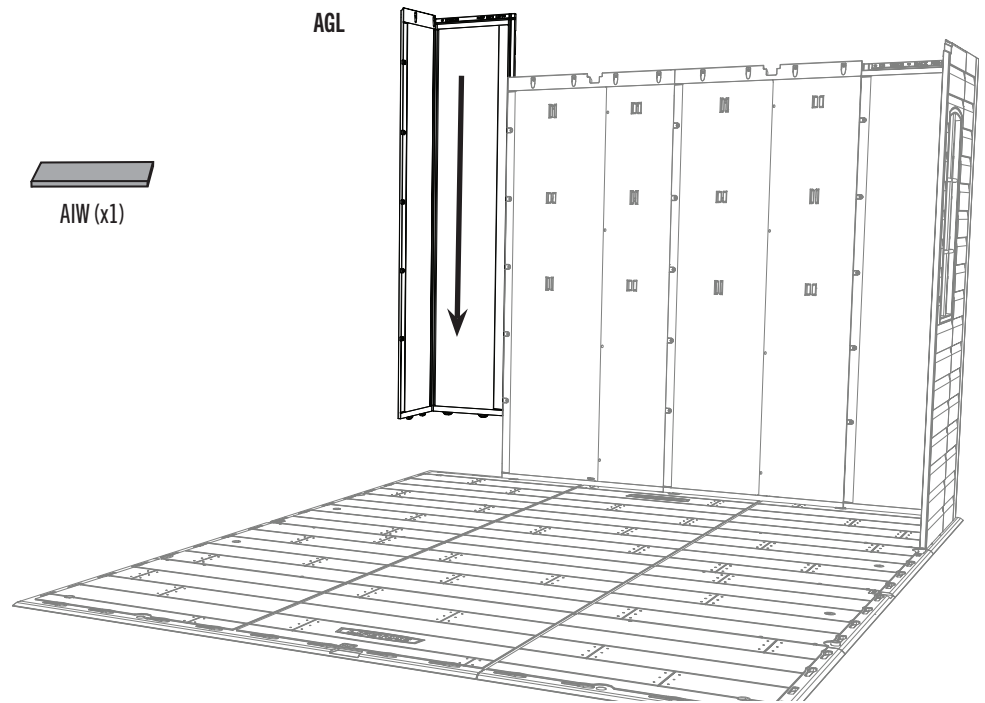

### 7.11



- Insert three (3) **wall panels (AHD)** with the **wall channel supports (AFM)** along the rear edge of the floor, and secure using five (5) **screws (ADZ)** each.
- Insérez trois (3) **panneaux muraux (AHD)** en disposant les **renforts de soutien mural (AFM)** le long de la limite arrière du plancher, puis fixez chacun d'eux en place à l'aide de cinq (5) **vis (ADZ)**.
- Inserte tres (3) **paneles de pared (AHD)** con los **canales soportes de pared (AFM)** a lo largo del borde trasero del piso, y asegúrelo utilizando cinco (5) **tornillos (ADZ)** para cada uno.

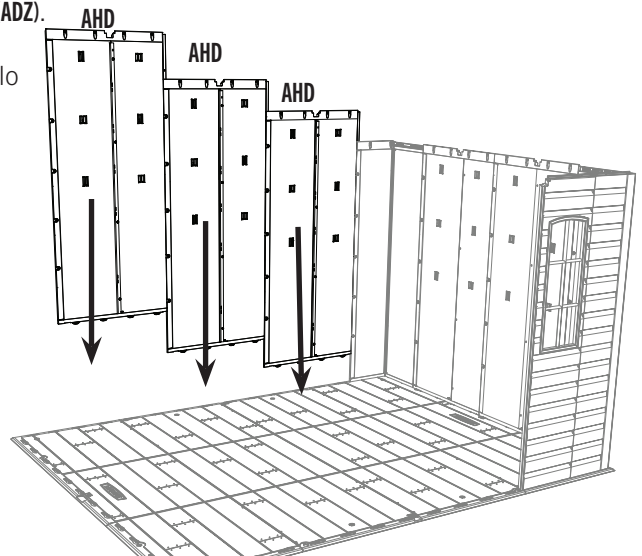

## ► SECTION 7 (CONTINUED) / SECTION 7 (SUITE) / SECCIÓN 7 (CONTINUACIÓN)

TOOLS AND HARDWARE REQUIRED / OUTILS ET QUINCAILLERIE REQUIS / INSTRUMENTAL Y HERRAJE REQUERIDOS

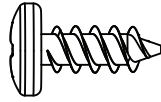

ADZ (x15)

### 7.12



- For the left, rear **corner panel (AGW)**, repeat the step you did for the right, front corner panel.
- Pour le **panneau angulaire (AGW)** arrière gauche, répétez les étapes réalisées pour le panneau angulaire avant droit.
- Para el **panel angular (AGW)** trasero izquierdo, repita los pasos que se efectuaron para el panel angular delantero derecho.



AIW (x1)

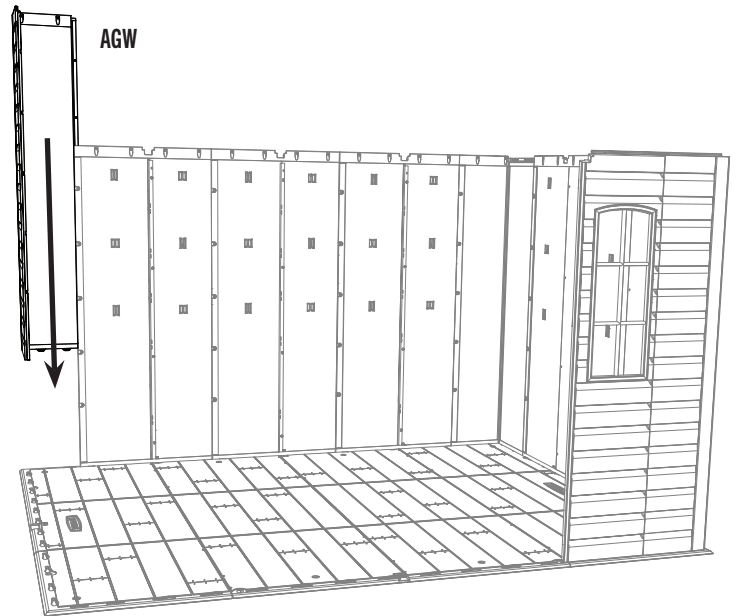

### 7.13

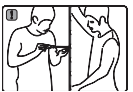

- Insert two (2) **wall panels (AHD)** and secure using five (5) **screws (ADZ)** each. Insert the two (2) wall panels (AHD) WITHOUT the wall support channels here.
- Inérez deux (2) **panneaux muraux (AHD)** et attachez-les l'un à l'autre à l'aide de cinq (5) **vis (ADZ)** chaque un. Insérer les deux (2) panneaux muraux (AHD) SANS les canaux de support mural ici.
- Inserte dos (2) **paneles murales (AHD)** y sujételos usando cinco (5) **tornillos (ADZ)** cada uno. Insertar los dos (2) paneles murales (AHD) SIN los canales de soporte de muros aquí.

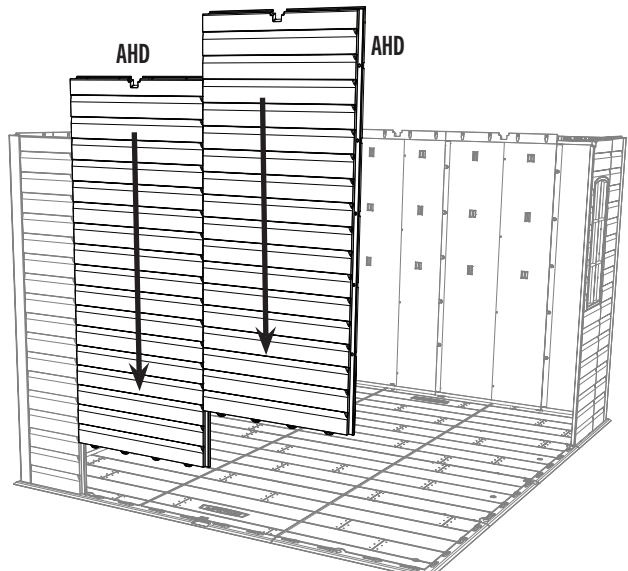

## ► SECTION 7 (CONTINUED) / SECTION 7 (SUITE) / SECCIÓN 7 (CONTINUACIÓN)

TOOLS AND HARDWARE REQUIRED / OUTILS ET QUINCAILLERIE REQUIS / INSTRUMENTAL Y HERRAJE REQUERIDOS

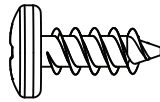

ADZ (x10)

### 7.14

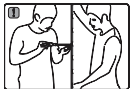

- For the left, front **corner panel (AGL)**, repeat the step you did for the right, front corner panel.
- Pour le **panneau angulaire (AGL)** avant gauche, répétez les étapes réalisées pour le panneau angulaire avant droit.
- Para el **panel angular (AGL)** delantero izquierdo, repita los pasos que se efectuaron para el panel angular delantero derecho.



AIW (x1)

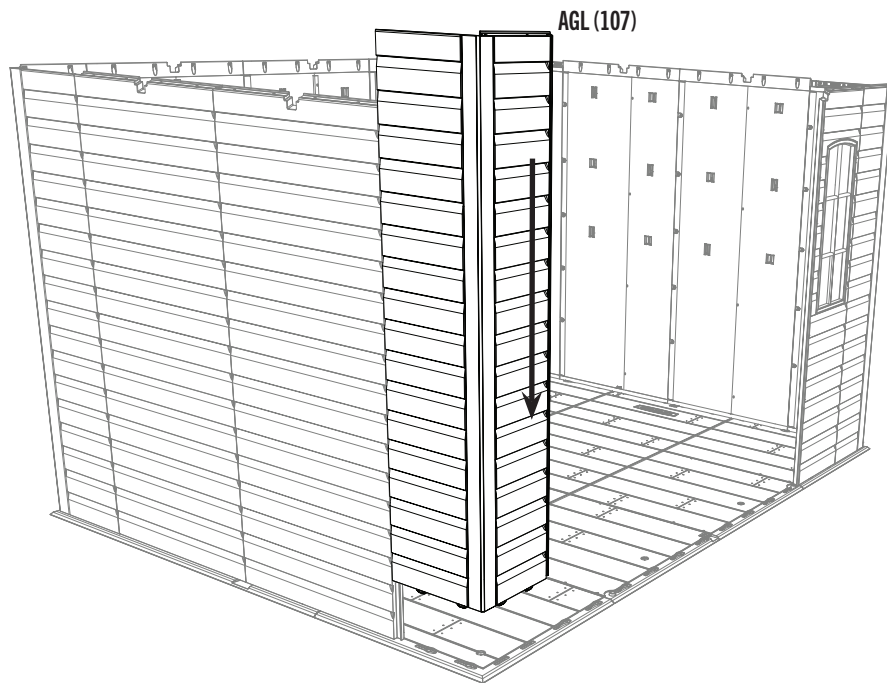

### 7.15

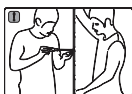

- Insert tabs at the bottom of the **left window wall panel (BDH)** into the third and fourth slots from the front, right corner of the floor. Slide the panel to the left. Secure the two panels using five (5) **screws (ADZ)**.
- Insérez les languettes au bord inférieur du **panneau mural gauche pour la fenêtre (BDH)** dans les troisième et quatrième rainures du coin droit du plancher. Faites glisser le panneau à gauche. Bien attachez les deux panneaux à l'aide de cinq (5) **vis (ADZ)**.
- Introduzca las lengüetas al borde inferior del **Panel mural izquierdo para la ventana (BDH)** en las tercera y cuarta ranuras de la esquina derecha del piso. Deslice el panel a la izquierda. Sujete los dos paneles usando cinco (5) **tornillos (ADZ)**.

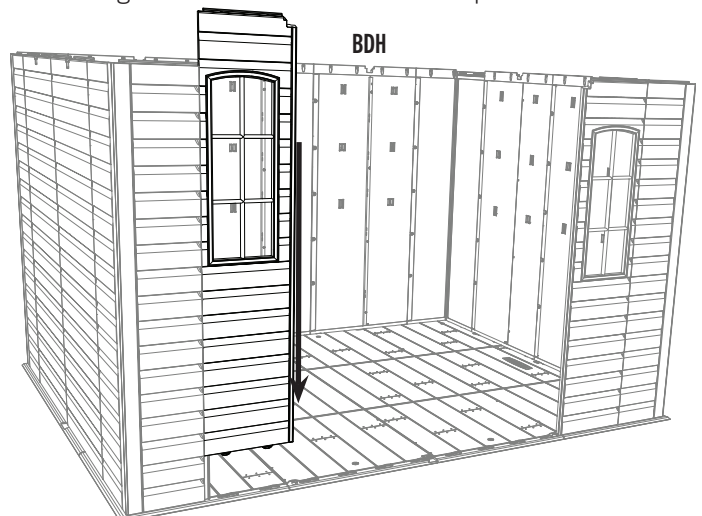

## ► SECTION 7 (CONTINUED) / SECTION 7 (SUITE) / SECCIÓN 7 (CONTINUACIÓN)

TOOLS AND HARDWARE REQUIRED / OUTILS ET QUINCAILLERIE REQUIS / INSTRUMENTAL Y HERRAJE REQUERIDOS

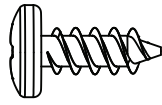

ADZ (x4)

# 7.16

- Four (4) screws (ADZ) are used in the channel (AFM).
- Bien attachez le support (AFM) à l'aide de quatre (4) vis (ADZ).
- Sujete el canal (AFM) usando cuatro (4) tornillos (ADZ).



- The top hole does not use a screw.
- Ne pas insérer une vis à travers le trou supérieur.
- No inserte un tornillo en el agujero superior.

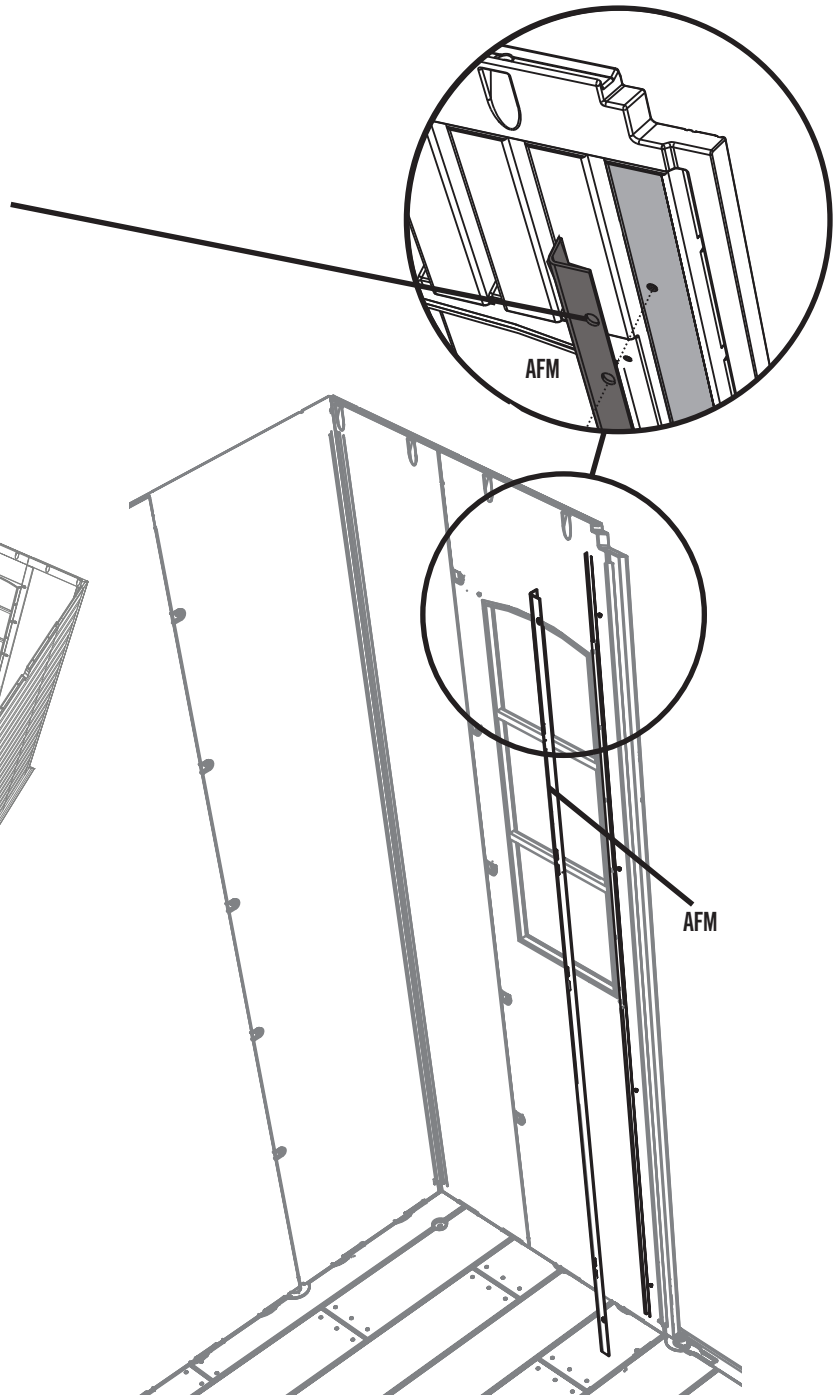
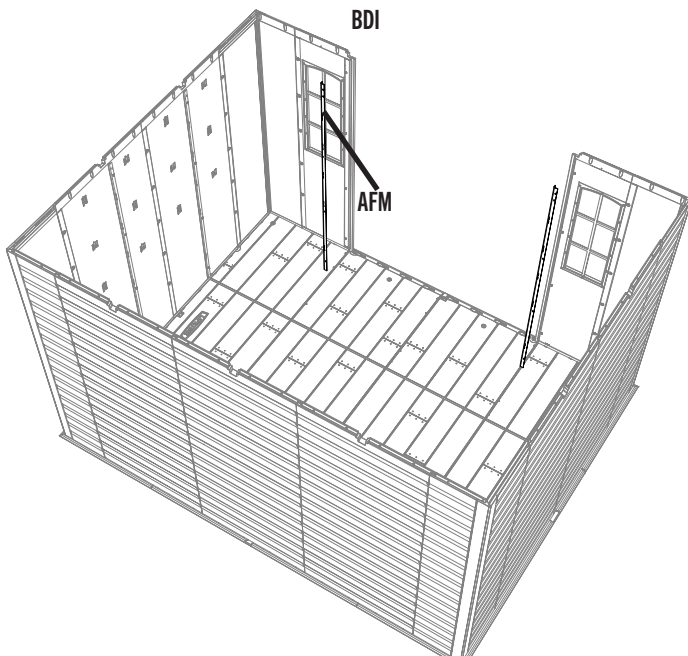

## ► SECTION 7 (CONTINUED) / SECTION 7 (SUITE) / SECCIÓN 7 (CONTINUACIÓN)

TOOLS AND HARDWARE REQUIRED / OUTILS ET QUINCAILLERIE REQUIS / INSTRUMENTAL Y HERRAJE REQUERIDOS

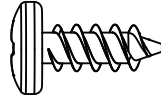

ADZ (x4)

### 7.17

- Four (4) screws (ADZ) are used in the channel (AFM).
- Bien attachez le support (AFM) à l'aide de quatre (4) vis (ADZ).
- Sujete el canal (AFM) usando cuatro (4) tornillos (ADZ).



- The top hole does not use a screw.
- Ne pas insérer une vis à travers le trou supérieur.
- No inserte un tornillo en el agujero superior.

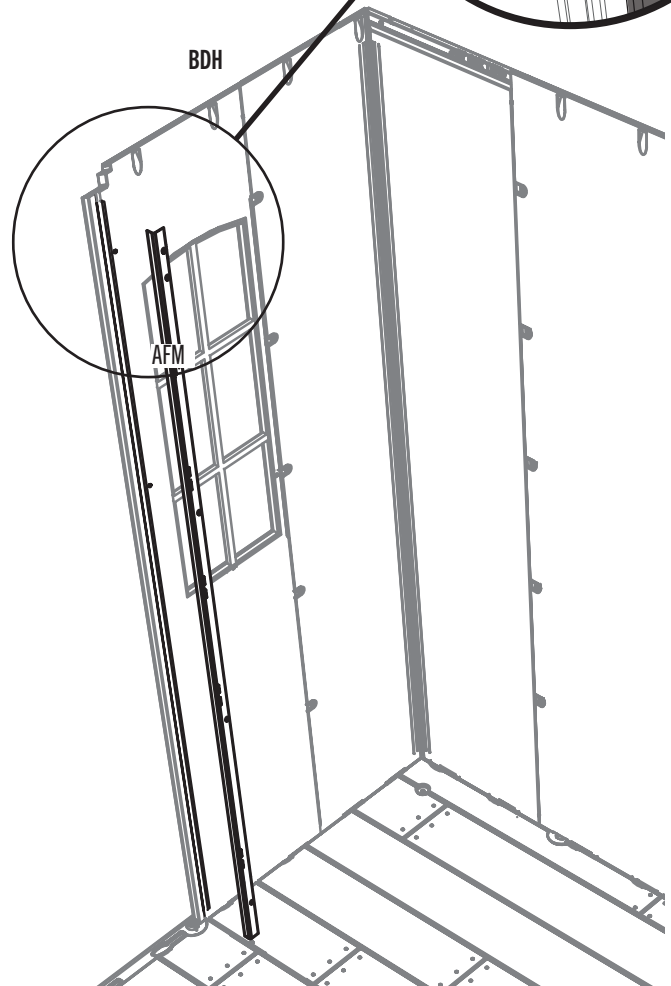
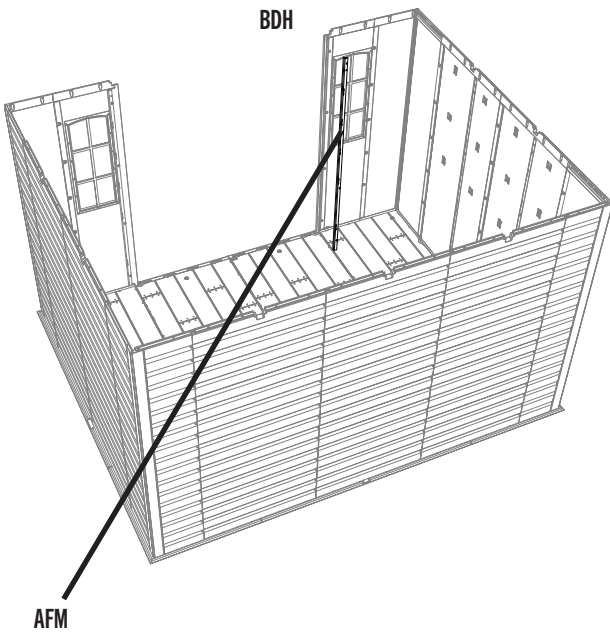
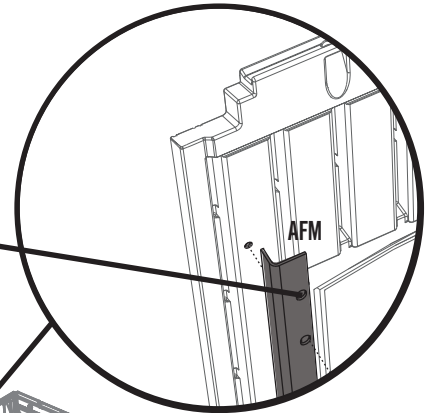



### HARDWARE REQUIRED / QUINCAILLERIE REQUISE / HERRAJE REQUERIDO

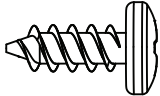

ADZ (x32)

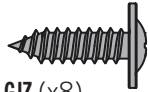

GJZ (x8)

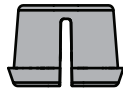

FEX (x8)

Parts / Pièces / Piezas

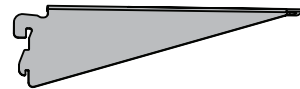

AIY (x4)



### PARTS REQUIRED / PIÈCES REQUISES / PIEZAS REQUERIDAS

Metal parts / Pièces en métal / Piezas de metal

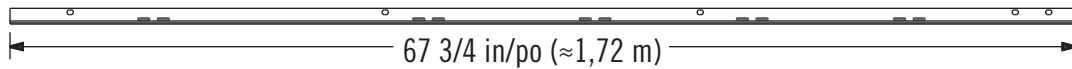

AFM (x4)

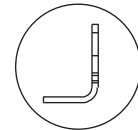

HDU (x2)

HDT (x2)

Plastic parts / Pièces en plastique / Piezas de plástico

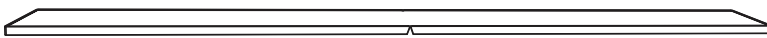

AFV (x2)

SMALL PARTS BOX / PETITES PIÈCES / PIEZAS PEQUEÑAS

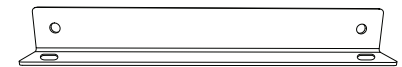

HDV (x4)



### TOOLS REQUIRED / OUTILS REQUIS / INSTRUMENTAL REQUERIDO

(Not included—unless otherwise indicated\*) / (Non inclus — sauf indication contraire\*) / (No incluido, salvo indicación contraria\*)



## ► SECTION 8 (CONTINUED) / SECTION 8 (SUITE) / SECCIÓN 8 (CONTINUACIÓN)

TOOLS AND PARTS REQUIRED / OUTILS ET QUINCAILLERIE REQUIS / INSTRUMENTAL Y HERRAJE REQUERIDOS

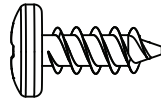

ADZ (x8)



- In case of any trouble with this section, scan the QR code below to view a video on its assembly.
- En cas de problème avec cette section, scanner le QR code en dessous pour voir une vidéo de l'assemblage.
- En caso de problemas con esta sección, escanear el código QR debajo para ver un video del ensamblaje.



<http://go.lifetime.com/10x8-section8>

### 8.1

- The right **wall/shelf support channel (AFM)** goes in the slot directly under the notch in the wall panel. The left wall support channel goes in the slot to the right of the notch in the wall panel.
- Le **canal de support du mur/étagère (AFM)** droit s'attache dans la rainure directement sous l'encoche dans le panneau mural. Le canal de support du mur/étagère gauche s'attache dans la rainure à la droite de l'encoche du panneau mural.
- El **canal de soporte para la pared/estante (AFM)** derecho se sujeta dentro de la ranura directamente debajo la muesca en el panel de pared. El canal de soporte para la pared izquierdo se sujeta dentro de la ranura a la derecha de la muesca en el panel de pared.

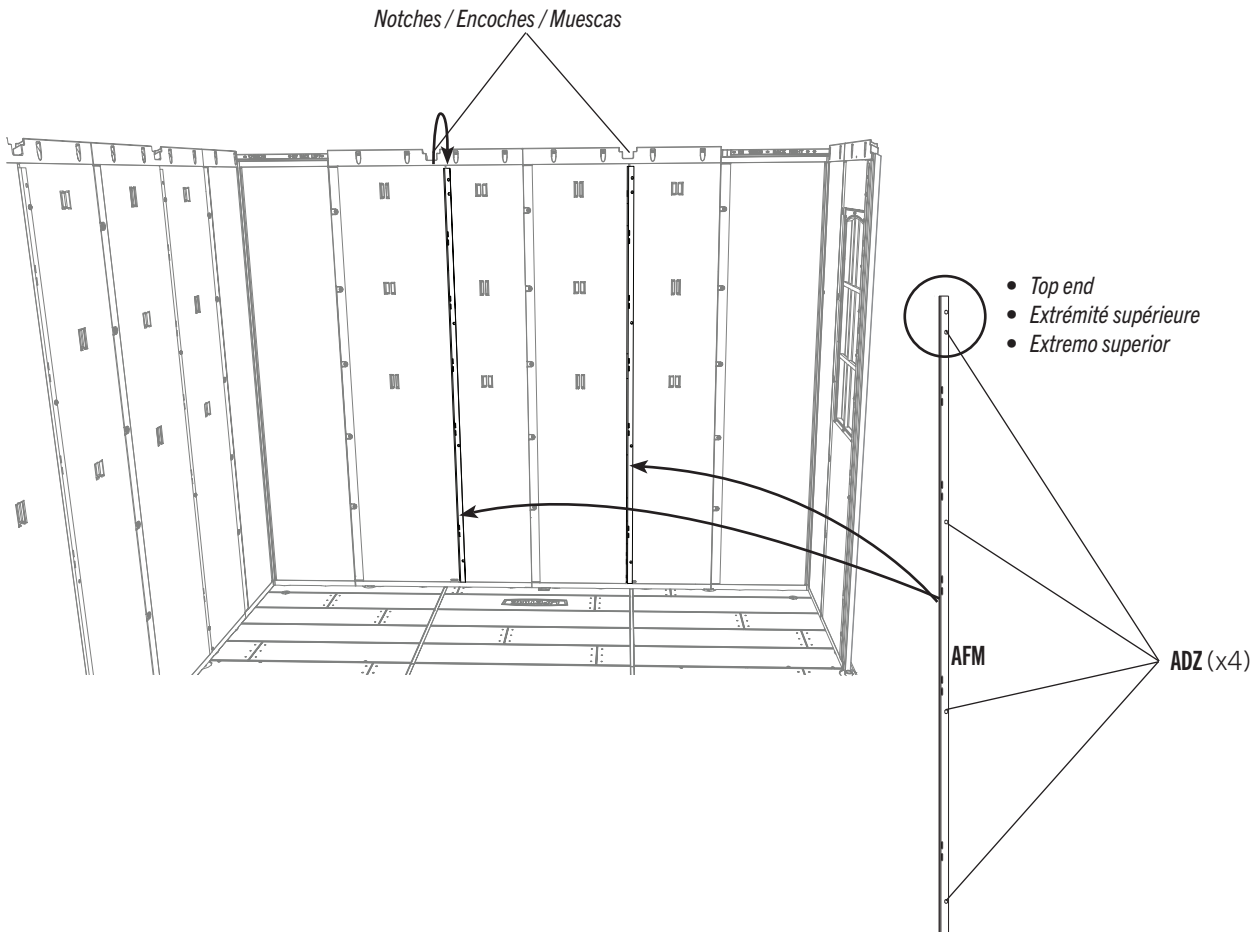



## ► SECTION 8 (CONTINUED) / SECTION 8 (SUITE) / SECCIÓN 8 (CONTINUACIÓN)

TOOLS AND PARTS REQUIRED / OUTILS ET QUINCAILLERIE REQUIS / INSTRUMENTAL Y HERRAJE REQUERIDOS

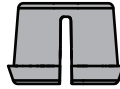

FEX (x4)

### 8.2

- Insert the **shelf brackets (AIY)** into the slots in the wall/shelf support channels. **The brackets must be at the same height.**
- Insérer les **équerres (AIY)** dans les fentes dans les canaux de support pour les murs/étagères. **Les équerres doivent être à la même hauteur.**
- Insertar las **escuadras (AIY)** en las ranuras en los canales de soporte para las paredes/estantes. **Las escuadras deben estar a la misma altura.**

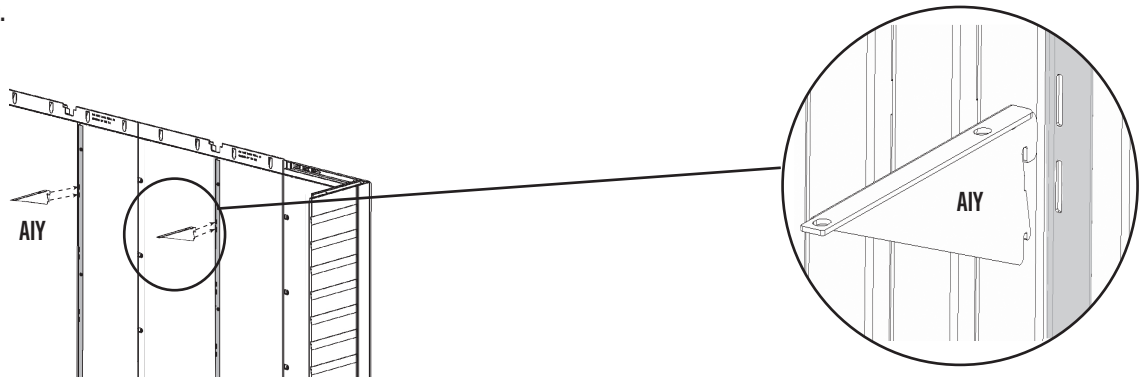

### 8.3

- Place **screw anchors (FEX)** into the side walls at the same level the shelf braces were placed.
- Placez les **vis d'ancrage (FEX)** dans les murs de côté à la même hauteur que vous avez placé les renforts de l'étagère.
- Coloque los **anclajes de tornillo (FEX)** en las paredes laterales al mismo nivel en el que se colocaron los soportes del estante.

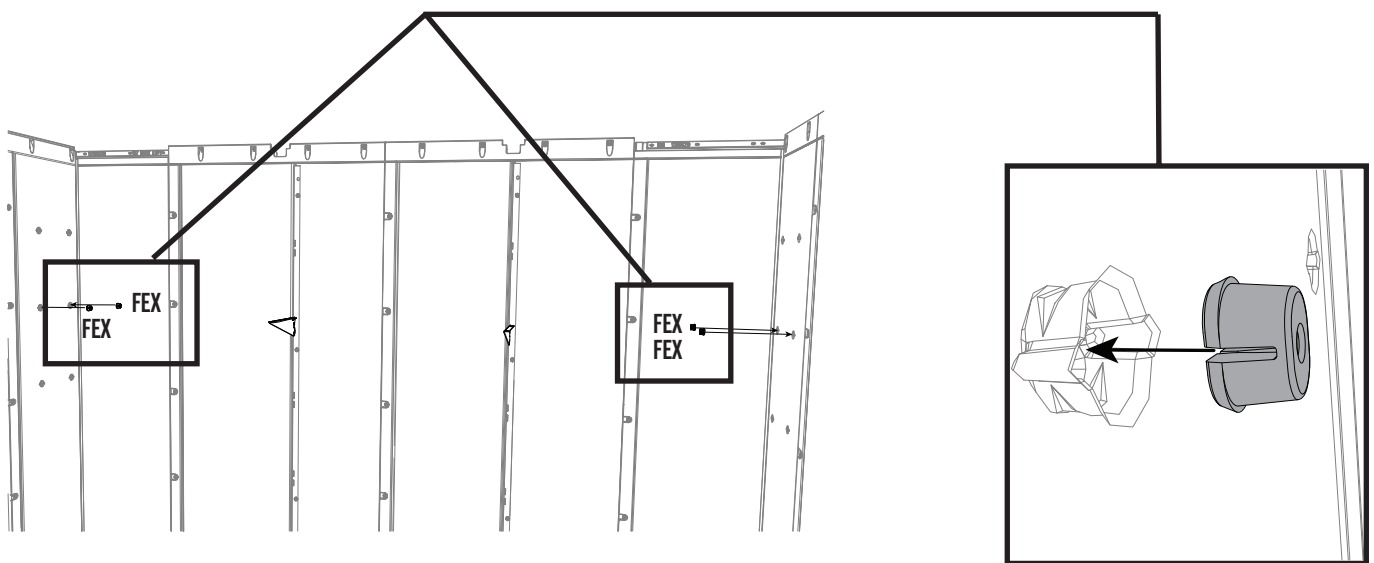

## ► SECTION 8 (CONTINUED) / SECTION 8 (SUITE) / SECCIÓN 8 (CONTINUACIÓN)

TOOLS AND PARTS REQUIRED / OUTILS ET QUINCAILLERIE REQUIS / INSTRUMENTAL Y HERRAJE REQUERIDOS

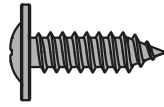

GJZ (x4)

### 8.4

- Attach a **shelf support bracket (HDV)** into the side wall at the same level the shelf braces were placed. Repeat for the other shelf support bracket on the opposite side.
- Placez le **support de l'étagère (HDV)** dans le mur de côté à la même hauteur que vous avez placé les renforts de l'étagère. Répétez pour le support de l'étagère de l'autre côté.
- Fije un **soporte de estante (HDV)** en la pared lateral al mismo nivel en el que se colocaron los soportes del estante. Repita para el otro soporte de estante en el lado opuesto.

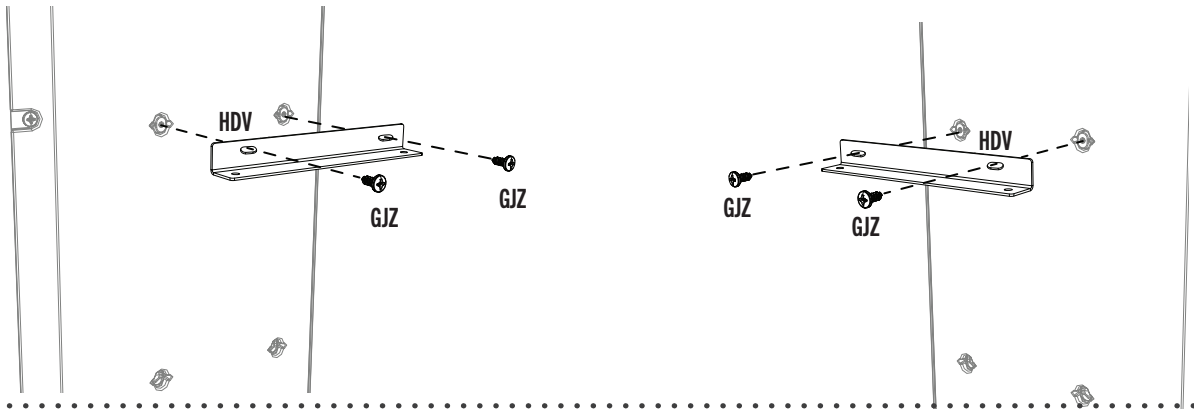

### 8.5

- *Unfold the shelf before installing.*
- *Dépliez l'étagère avant l'installation.*
- *Despliegue el estante antes de instalar.*

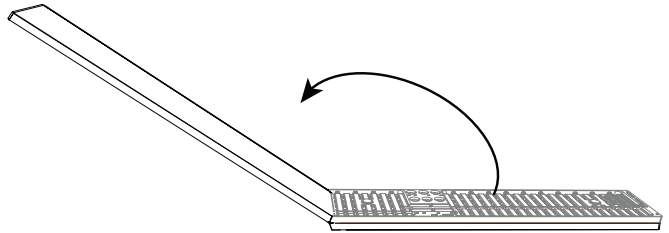

### 8.6

- Snap the **short and long shelf support tubes (HDT and HDU)** into the underside of the shelf. The long shelf support tube should be put in place near the side labelled "Front".
- Clipsez les **tubes d'appui long et court de l'étagère (HDT et HDU)** sous l'étagère. Le tube d'appui long doit être mis en place près du côté marqué « Devant ».
- Conecte a presión los **tubos de soporte del estante corto y largo (HDT y HDU)** en la parte inferior del estante. El tubo de soporte largo del estante debería ponerse en su lugar cerca del lado etiquetado "Front".

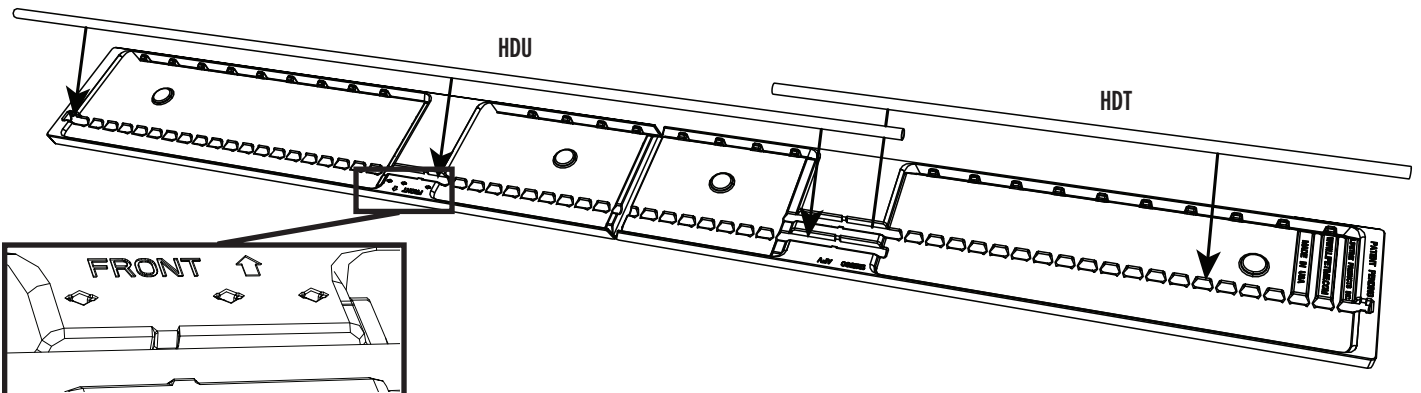

## ► SECTION 8 (CONTINUED) / SECTION 8 (SUITE) / SECCIÓN 8 (CONTINUACIÓN)

TOOLS AND PARTS REQUIRED / OUTILS ET QUINCAILLERIE REQUIS / INSTRUMENTAL Y HERRAJE REQUERIDOS

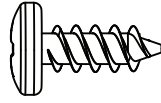

ADZ (x8)

### 8.7

- Attach the **shelf (AFV)** to the corner wall panels and shelf support brackets using eight (8) **screws (ADZ)**.
- Attachez l'**étagère (AFV)** aux panneaux de mur de coin et aux supports de l'étagère à l'aide de huit (8) **vis (ADZ)**.
- Fije el **estante (AFV)** a los paneles de pared de esquina y a los soportes del estante usando ocho (8)  **tornillos (ADZ)**.

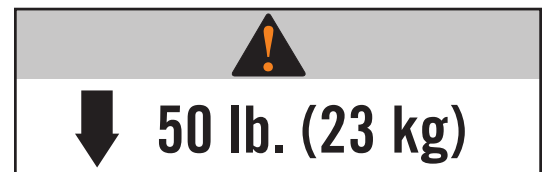
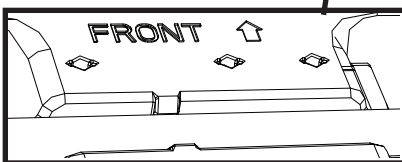
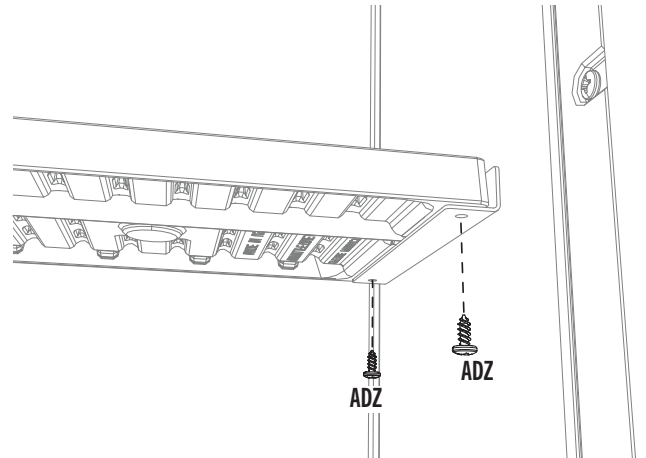
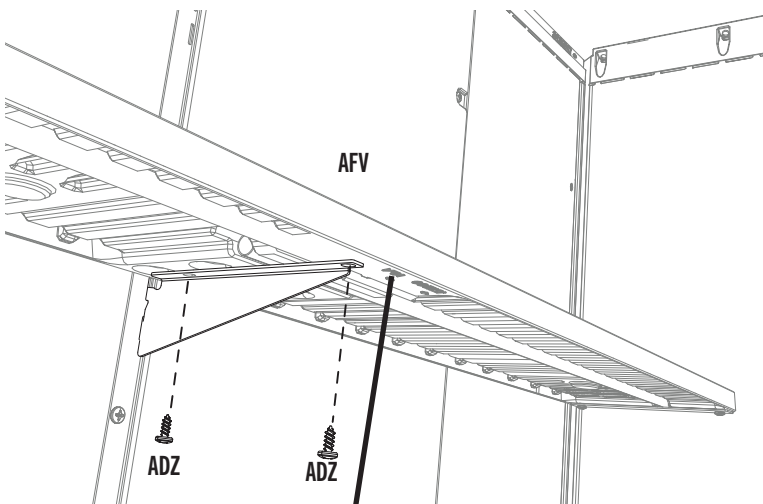
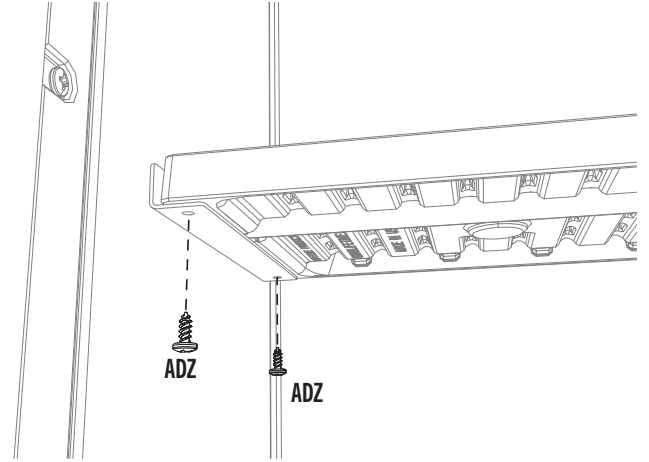
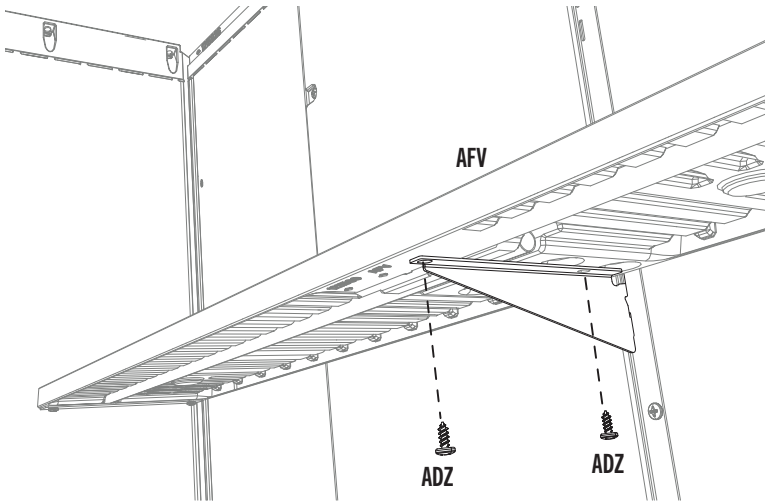

## ► SECTION 8 (CONTINUED) / SECTION 8 (SUITE) / SECCIÓN 8 (CONTINUACIÓN)

TOOLS AND PARTS REQUIRED / OUTILS ET QUINCAILLERIE REQUIS / INSTRUMENTAL Y HERRAJE REQUERIDOS



FEX (x4)

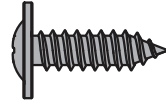

GJZ (x4)

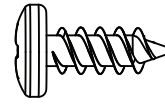

ADZ (x16)

### 8.8



- Repeat steps 8.2–8.7 to install the second shelf on the opposite wall.
- Répétez les étapes 8.2 – 8.7 pour installer le deuxième étagère sur le mur opposé.
- Repita los pasos 8.2–8.7 para instalar el segundo estante en el muro opuesto.

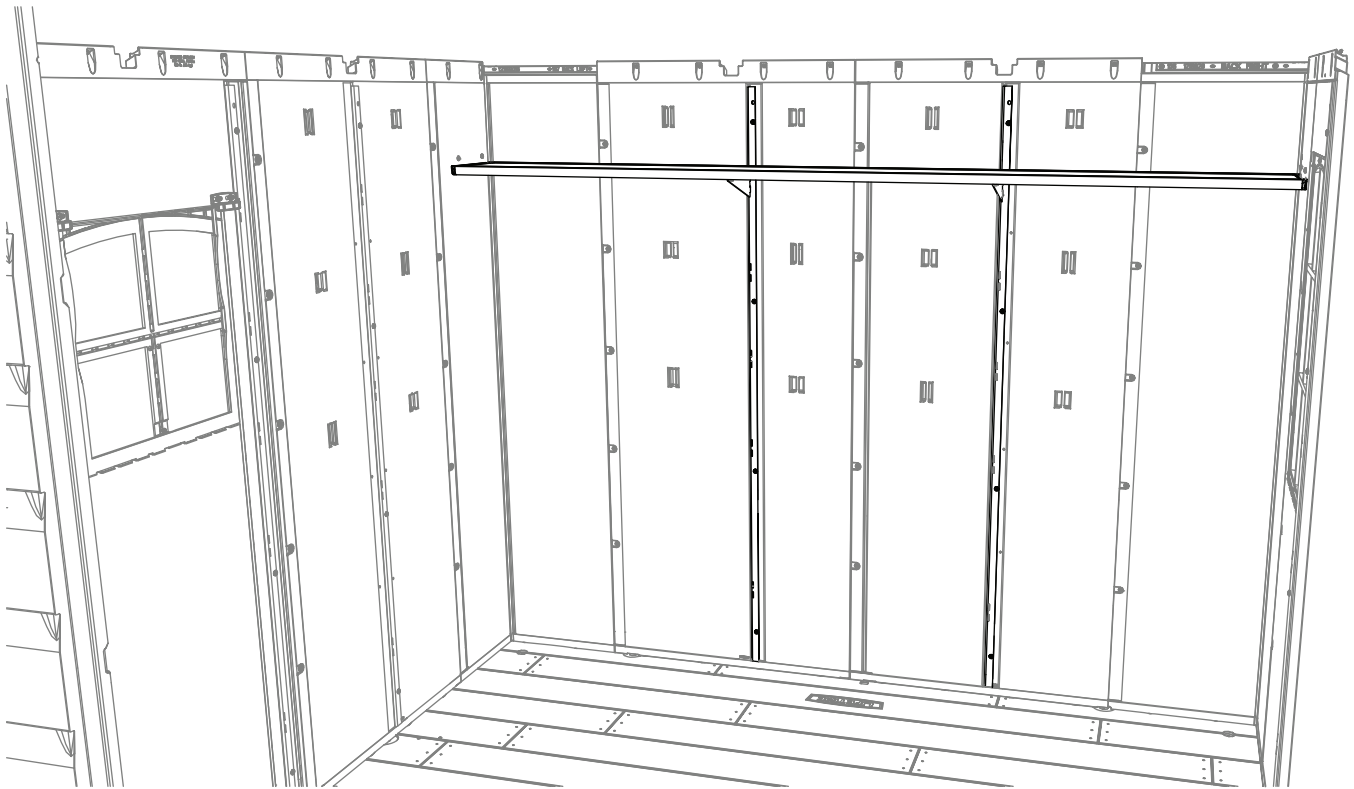



HARDWARE REQUIRED / QUINCAILLERIE REQUISE / HERRAJE REQUERIDO

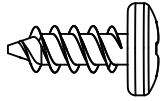

ADZ (x160)



DTV (x2)



ADX (x24)



AHP (x2)

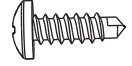

BHJ (x2)

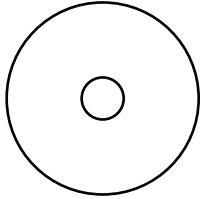

AED (x24)

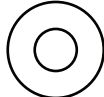

AEE (x2)



CXK (x2)

Parts / Pièces / Piezas

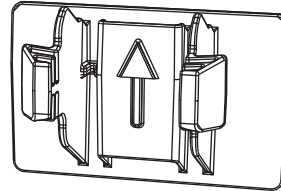

AXX (x4)

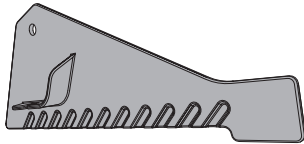
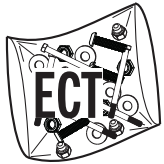

ECR (x1)

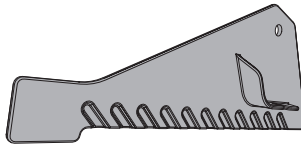

ECS (x1)



ADK (x2)

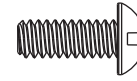

BZA (x2)

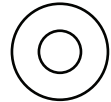

AEE (x4)



PARTS REQUIRED / PIÈCES REQUISES / PIEZAS REQUERIDAS

Metal parts / Pièces en métal / Piezas de metal



AFL (x6)

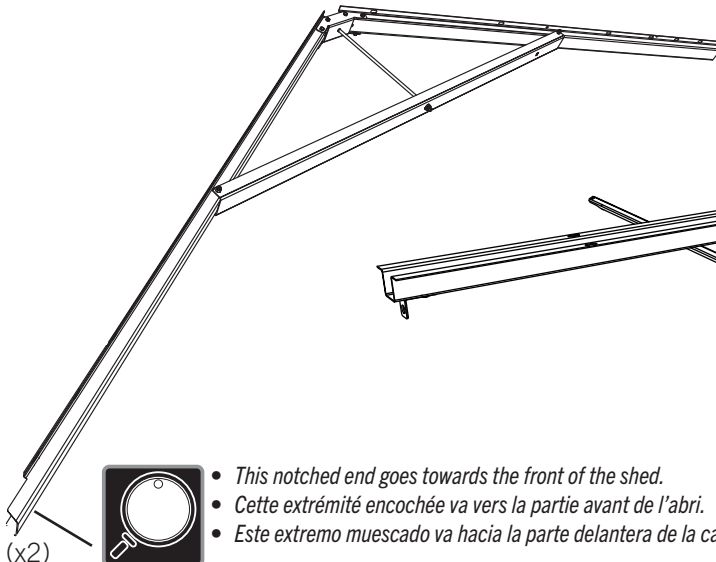

(x2)

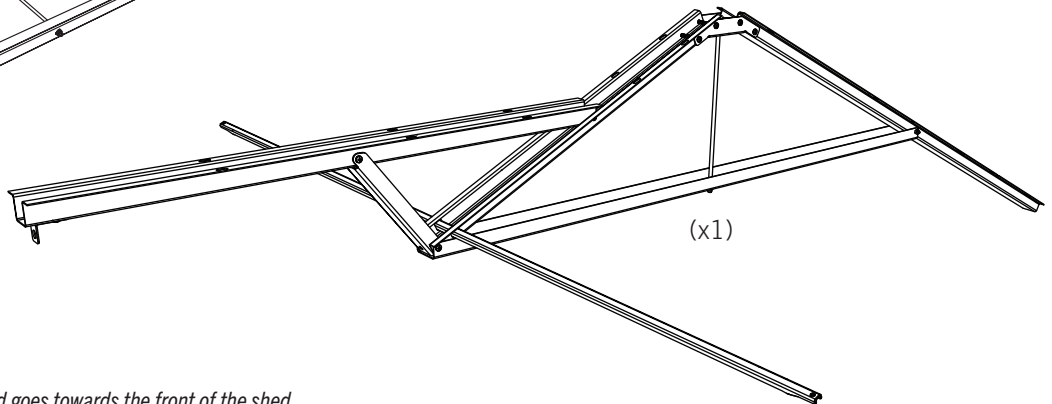

(x1)



- This notched end goes towards the front of the shed.
- Cette extrémité encochée va vers la partie avant de l'abri.
- Este extremo muescado va hacia la parte delantera de la caseta.



PARTS REQUIRED / PIÈCES REQUISES / PIEZAS REQUERIDAS

Plastic parts / Pièces en plastique / Piezas de plástico

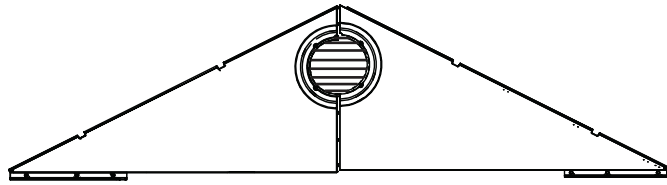

(x2)

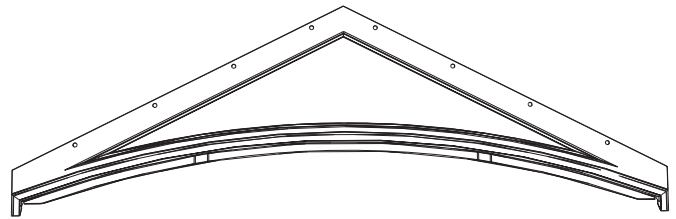

(x1)

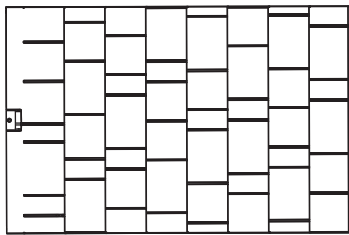

AGQ (x6)

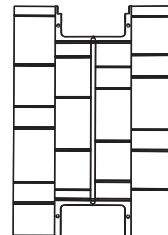

AFY (x3)

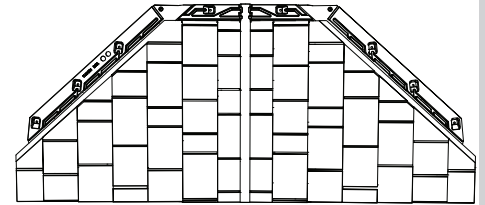

DRA (x1)

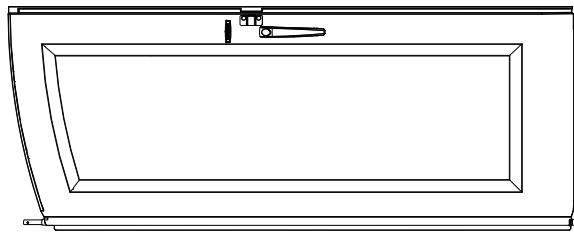

(x1)

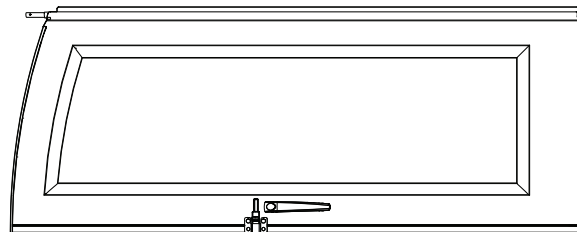

(x1)

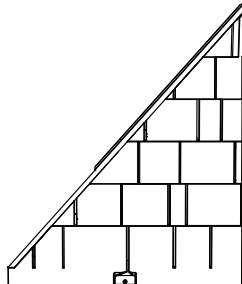

BDS (x1)

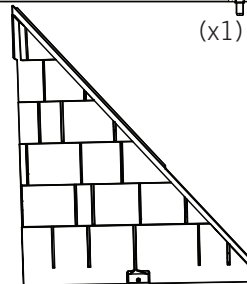

BDR (x1)

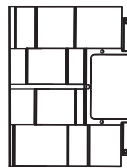

AGG (x1)

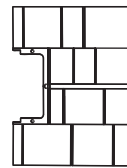

AFW (x1)

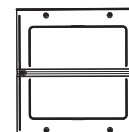

AHC (x4)

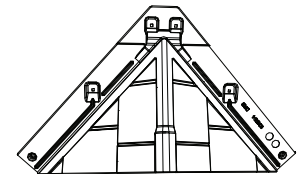

DRB (x1)



TOOLS REQUIRED / OUTILS REQUIS / INSTRUMENTAL REQUERIDO

(Not included—unless otherwise indicated\*) / (Non inclus — sauf indication contraire\*) / (No incluido, salvo indicación contraria\*)



3/8 in/po (≈10 mm)

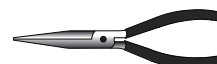

## ► SECTION 9 (CONTINUED) / SECTION 9 (SUITE) / SECCIÓN 9 (CONTINUACIÓN)

TOOLS AND HARDWARE REQUIRED / OUTILS ET QUINCAILLERIE REQUIS / INSTRUMENTAL Y HERRAJE REQUERIDOS

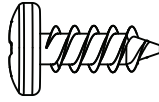

ADZ (x14)



- In case of any trouble with this section, scan the QR code below to view a video on its assembly.
- En cas de problème avec cette section, scanner le QR code en dessous pour voir une vidéo de l'assemblage.
- En caso de problemas con esta sección, escanear el código QR debajo para ver un video del ensamblaje.



<http://go.lifetime.com/10x8-section9>

### 9.1



- Set a side gable down onto the right side of the shed.
- Mettre un pignon latéral sur le côté droit de l'abri.
- Colocar una fachada lateral en el lado derecho de la caseta.

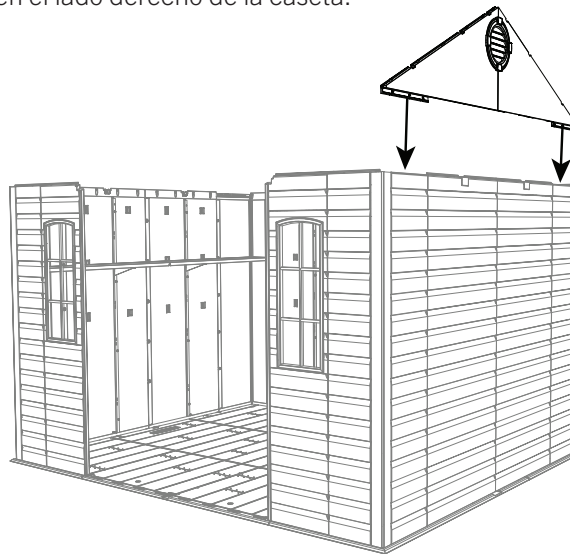

### 9.2

- Attach a side gable to the shed using fourteen (14) screws (ADZ).
- Attacher un pignon latéral à l'abri à l'aide de quatorze (14) vis (ADZ).
- Sujetar una fachada lateral a la caseta usando catorce (14) tornillos (ADZ).

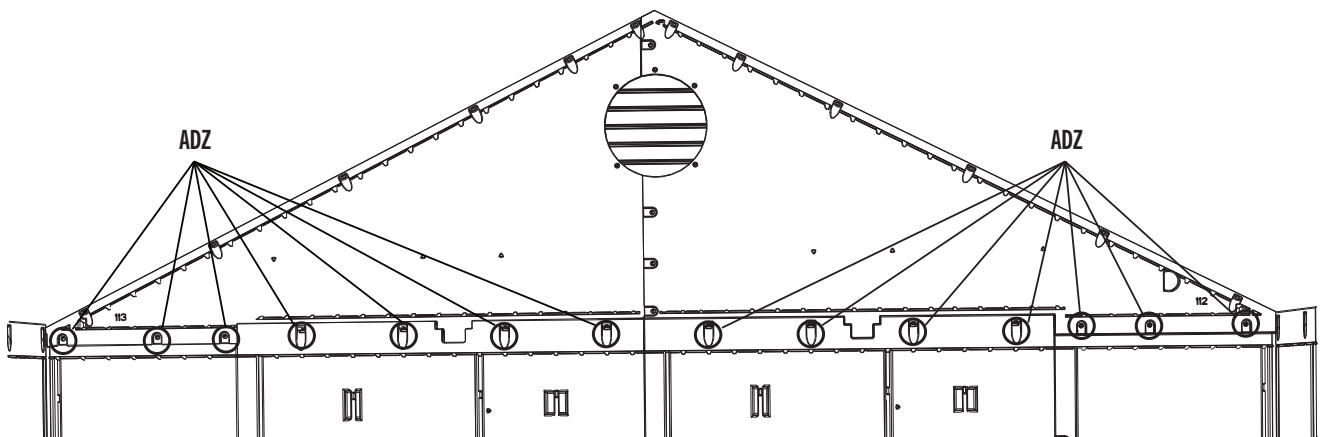

## ► SECTION 9 (CONTINUED) / SECTION 9 (SUITE) / SECCIÓN 9 (CONTINUACIÓN)

TOOLS AND HARDWARE REQUIRED / OUTILS ET QUINCAILLERIE REQUIS / INSTRUMENTAL Y HERRAJE REQUERIDOS



### 9.3

- Place a side truss into the notches on the rear wall panel and right front window wall panel. While another adult holds this in place, continue to the next step.
- Mettre une ferme latérale dans les encoches sur le panneau mural arrière et le panneau mural avant droit pour la fenêtre. Pendant qu'un autre adulte soutient la ferme en place, continuer à la prochaine étape.
- Colocar una cercha lateral en las muescas en el panel mural trasero y el panel mural delantero derecho para la ventana. Mientras que otro adulto mantenga la cercha en su lugar, seguir al próximo paso.



- *This notched end goes towards the front of the shed.*
- *Cette extrémité encochée va vers la partie avant de l'abri.*
- *Este extremo muescado va hacia la parte delantera de la caseta.*

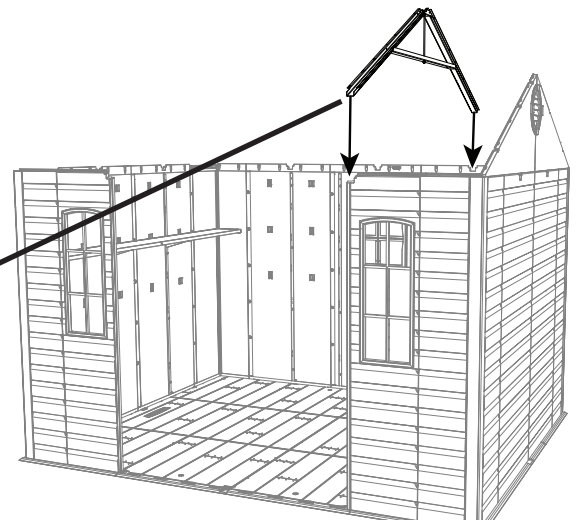

### 9.4

- Set the **roof panel (AGQ)** down onto the wall panel, gable, and truss. The groove at the bottom of the roof panel sets over the top of the wall panel. Ensure the alignment nub fits into the notch in the truss.
- Mettre le **panneau de toit (AGQ)** dans le panneau mural, le pignon, et la ferme. Mettre la rainure au bord inférieur du panneau de toit sur la partie supérieure du panneau mural. Mettre la petite bosse d'alignement dans l'encoche de la ferme.
- Colocar el **panel de tejado (AGQ)** en el panel de pared, la fachada, y la cercha. Colocar la ranura a lo largo del borde inferior del panel de tejado sobre la parte superior del panel de pared. Encajar el bulto de alineamiento en la muesca en la cercha.

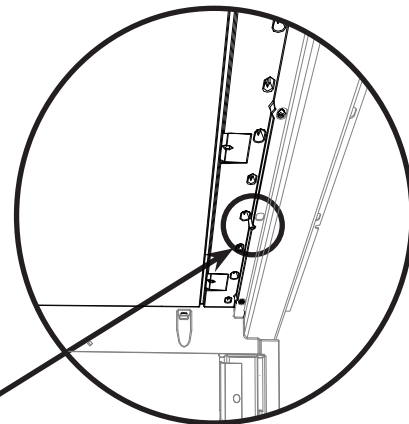
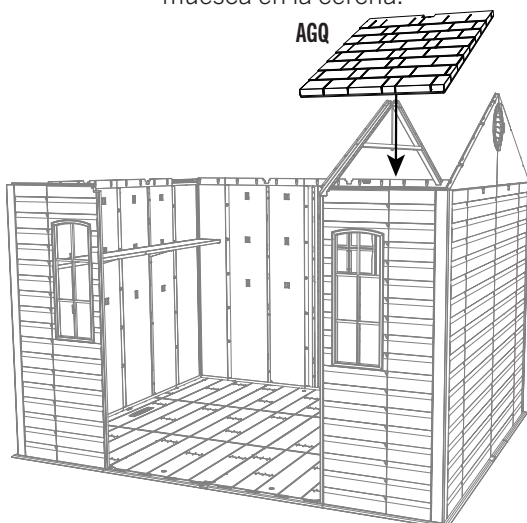

Alignment nub  
Petite bosse d'alignement  
Bulto de alineamiento



## ► SECTION 9 (CONTINUED) / SECTION 9 (SUITE) / SECCIÓN 9 (CONTINUACIÓN)

TOOLS AND HARDWARE REQUIRED / OUTILS ET QUINCAILLERIE REQUIS / INSTRUMENTAL Y HERRAJE REQUERIDOS

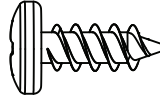

ADZ (x4)

### 9.5

- Align the four holes in the wall panel with those at the bottom of the roof panel, and insert four (4) **screws (ADZ)** to secure the panel in place.
- Aligner les quatre trous dans le panneau mural avec ceux au bord inférieur du panneau de toit, et insérer quatre (4) **vis (ADZ)** pour attacher le panneau en place.
- Alinear los cuatro agujeros en el panel de pared con los al borde inferior del panel de tejado, e insertar cuatro (4) **tornillos (ADZ)** para sujetarlo en su lugar.

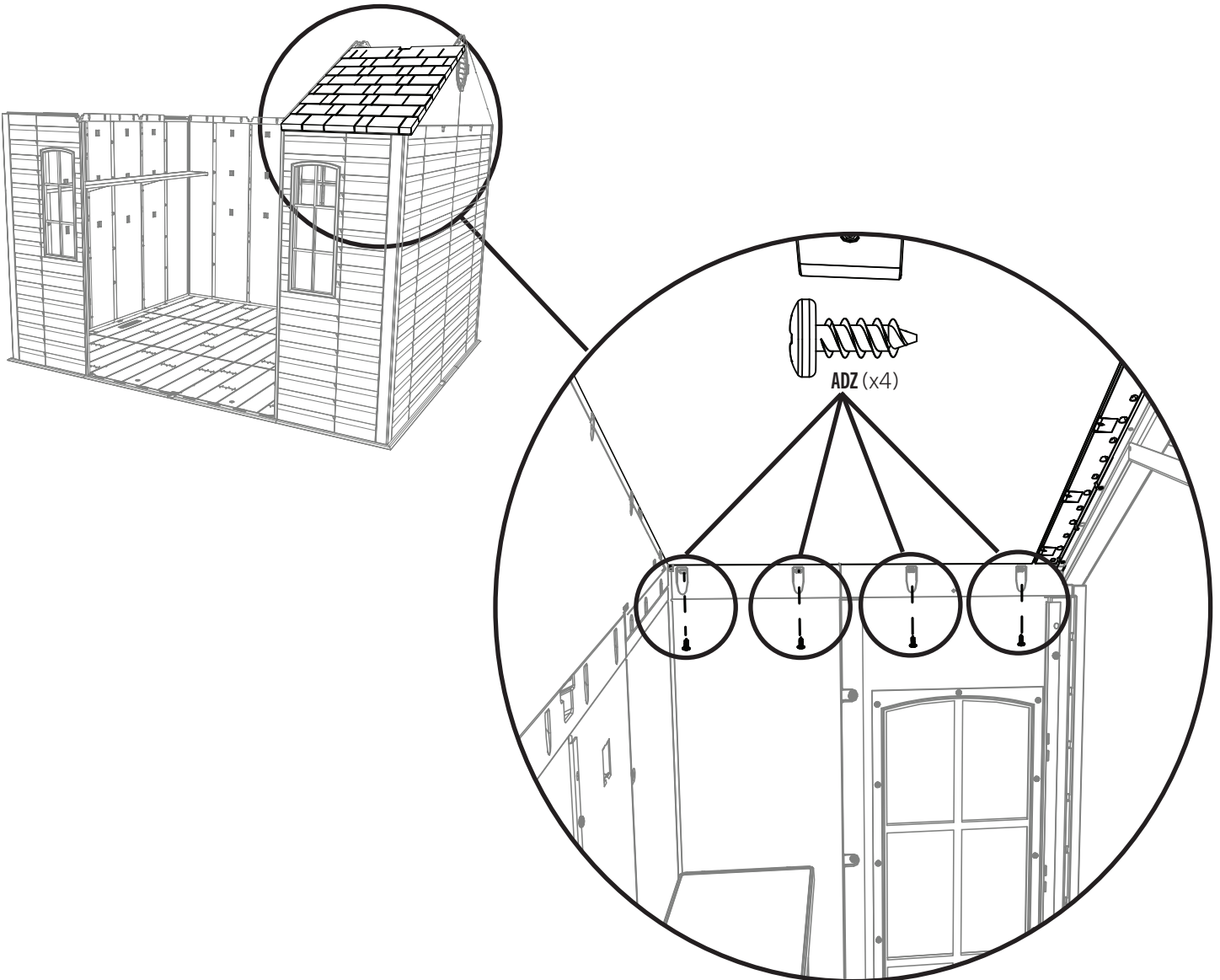

## ► SECTION 9 (CONTINUED) / SECTION 9 (SUITE) / SECCIÓN 9 (CONTINUACIÓN)

TOOLS AND HARDWARE REQUIRED / OUTILS ET QUINCAILLERIE REQUIS / INSTRUMENTAL Y HERRAJE REQUERIDOS

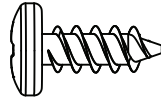

ADZ (x2)

### 9.6

- Insert the first two **screws (ADZ)** through the gable and into the roof panel at the locations shown. Insert the **roof support (AFL)** into the notches in the gable and between the truss and the roof panel.
- Insérer les premières deux **vis (ADZ)** à travers le pignon et dans le panneau de toit aux emplacements indiqués. Mettre le **support de toit (AFL)** dans les encoches dans le pignon et entre le panneau de toit et la ferme.
- Insertar los primeros dos **tornillos (ADZ)** por la fachada y dentro del panel de tejado a las ubicaciones indicadas. Insertar el **soporte de tejado (AFL)** en las muescas en la fachada y entre la cercha y el panel de tejado.

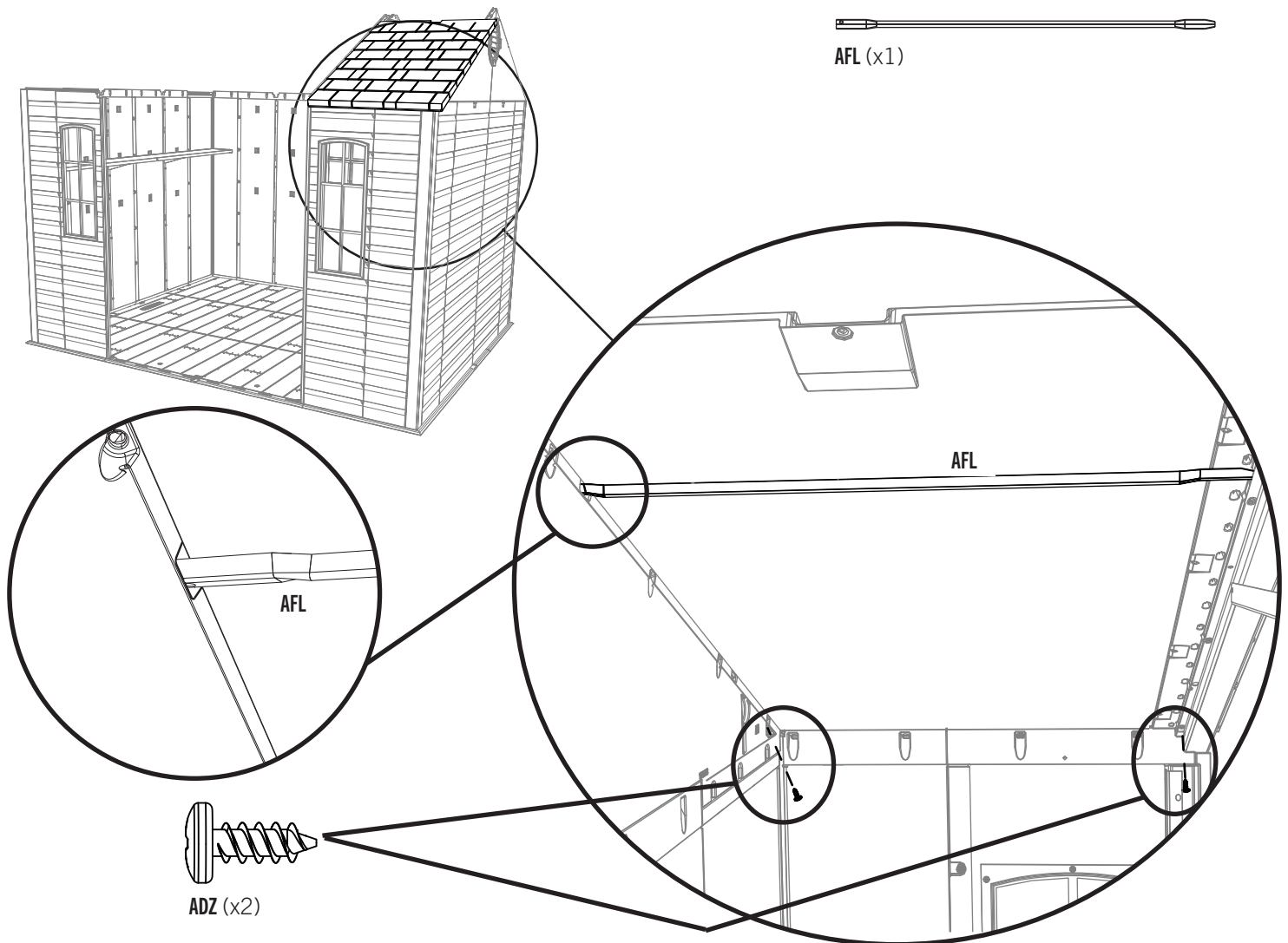

## ► SECTION 9 (CONTINUED) / SECTION 9 (SUITE) / SECCIÓN 9 (CONTINUACIÓN)

TOOLS AND HARDWARE REQUIRED / OUTILS ET QUINCAILLERIE REQUIS / INSTRUMENTAL Y HERRAJE REQUERIDOS

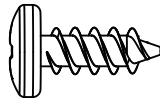

ADZ (x16)

### 9.7

- Insert two (2) screws (ADZ) through the gable and two (2) screws (ADZ) through the truss and into the roof panel at the locations shown. Insert the roof support (AFL) into the notches in the gable and between the truss and the roof panel. Finally, insert the last screw (ADZ) through the gable and into the roof panel at the location shown.
- Insérer deux (2) vis (ADZ) à travers le pignon et deux (2) vis (ADZ) à travers la ferme et dans le panneau de toit aux emplacements indiqués. Mettre le support de toit (AFL) dans les encoches dans le pignon et entre le panneau de toit et la ferme. En fin, insérer la dernière vis (ADZ) à travers le pignon et le panneau de toit à l'emplacement indiqué.
- Insertar dos tornillos (ADZ) por la fachada y dos (2) tornillos (ADZ) por la cercha y dentro del panel de tejado a las ubicaciones indicadas. Insertar el soporte de tejado (AFL) en las muescas en la fachada y entre la cercha y el panel de tejado. Por último, insertar el último tornillo (ADZ) por la fachada y dentro del panel de tejado a la ubicación indicada.

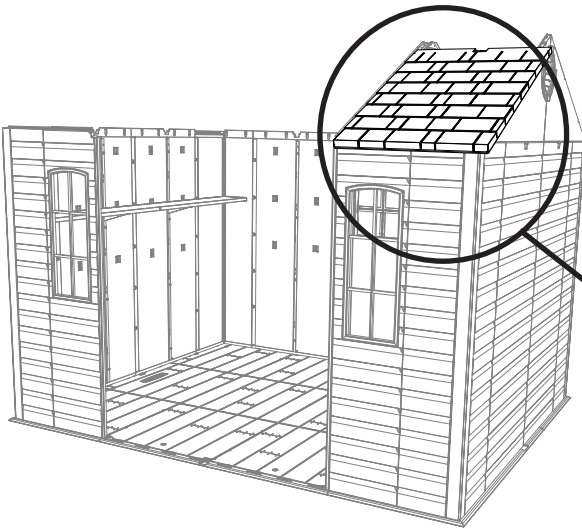

AFL (x1)

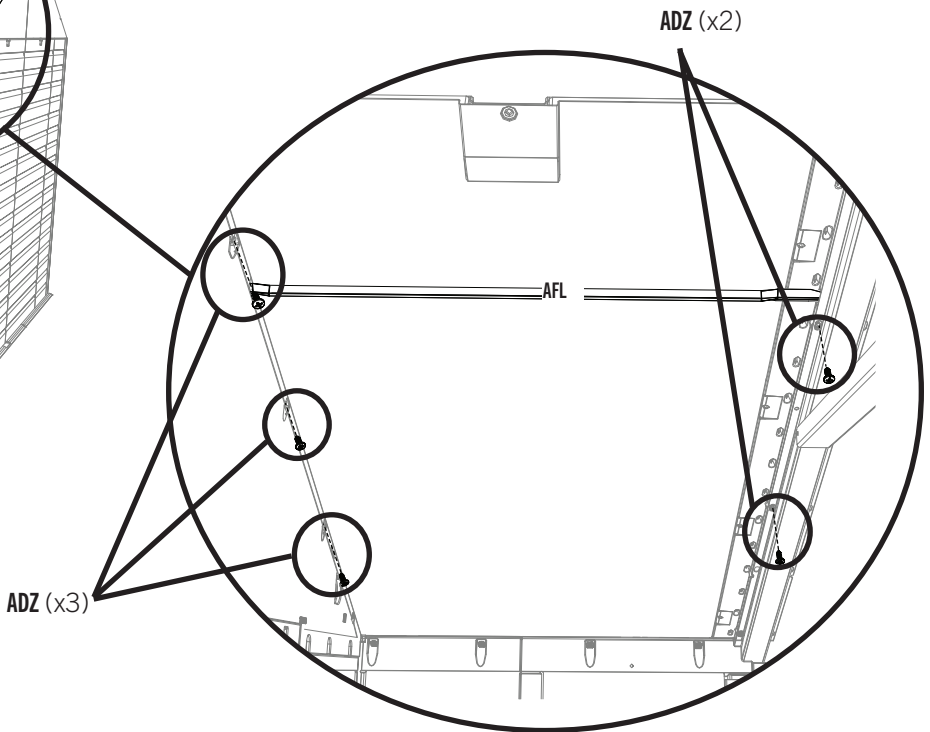
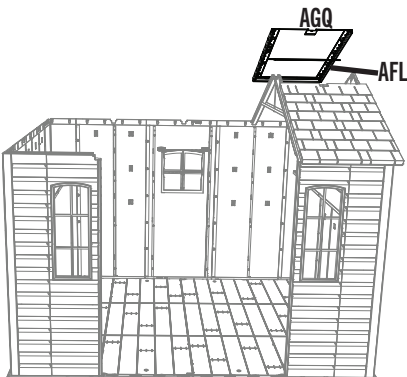

## ► SECTION 9 (CONTINUED) / SECTION 9 (SUITE) / SECCIÓN 9 (CONTINUACIÓN)

TOOLS AND HARDWARE REQUIRED / OUTILS ET QUINCAILLERIE REQUIS / INSTRUMENTAL Y HERRAJE REQUERIDOS

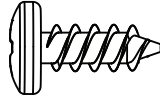

ADZ (x36)

### 9.8



- Repeat steps 9.1–9.7 for the left side of the shed.
- Répéter les étapes 9.1–9.7 pour le côté droit de l'abri.
- Repetir los pasos 9.1 - 9.7 para el lado izquierdo de la caseta.

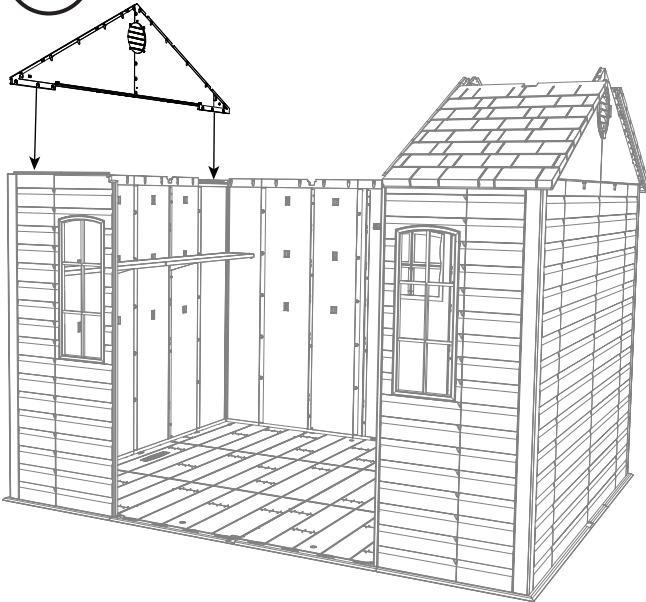

AFL (x2)

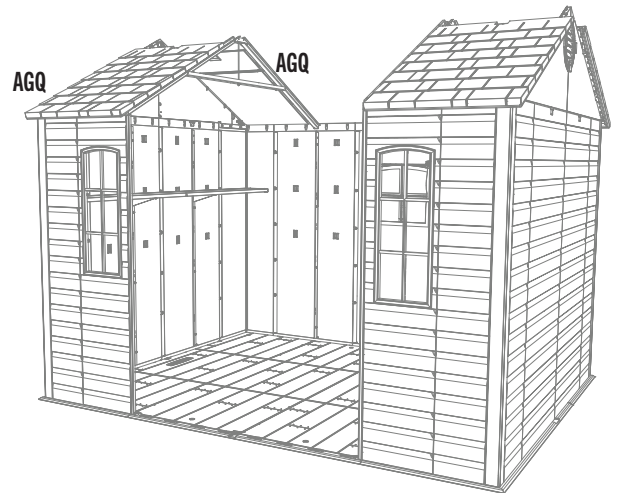

### 9.9



- Place the back of the center truss into the notch on the center rear wall panel. Then, lift the front of the truss up so the ends of the roof support tube touch the side trusses.
- Mettre l'extrémité arrière de la ferme centrale dans l'encoche sur le panneau mural arrière central. Ensuite, soulever l'extrémité avant de la ferme pour que les extrémités du tube de support touchent les fermes latérales.
- Colocar el extremo trasero de la cercha central en la muesca en el panel de tejado central trasero. Entonces, levantar el extremo delantero de la cercha para arriba para que los extremos del tubo de soporte hagan contacto con las cerchas laterales.

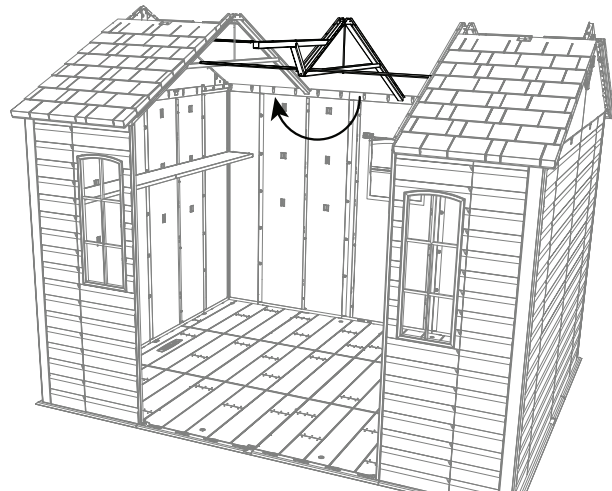
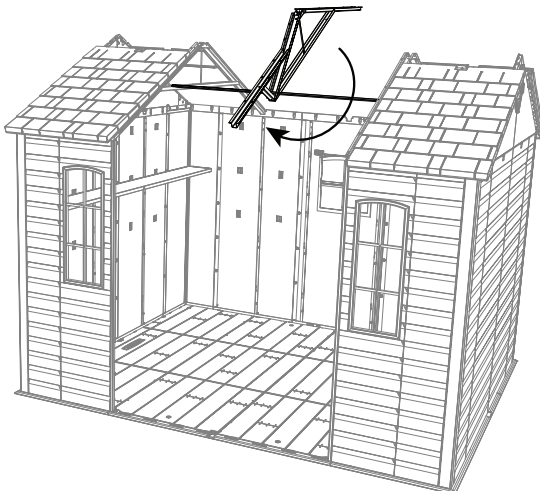

## ► SECTION 9 (CONTINUED) / SECTION 9 (SUITE) / SECCIÓN 9 (CONTINUACIÓN)

TOOLS AND HARDWARE REQUIRED / OUTILS ET QUINCAILLERIE REQUIS / INSTRUMENTAL Y HERRAJE REQUERIDOS



3/8 in/po  
(≈10 mm)

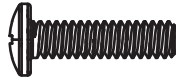

DTV (x2)

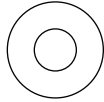

AEE (x2)



CXK (x2)

### 9.10



- Secure the ends of the support tube to the side truss channels using the hardware provided.
- Attacher bien les extrémités du tube de support aux fermes latérales à l'aide de la quincaillerie incluse.
- Sujetar los extremos del tubo de soporte a las cerchas laterales usando el herraje incluido.

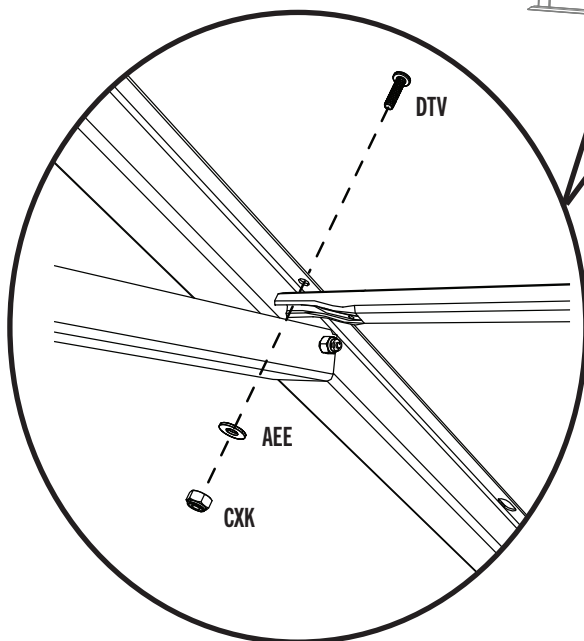
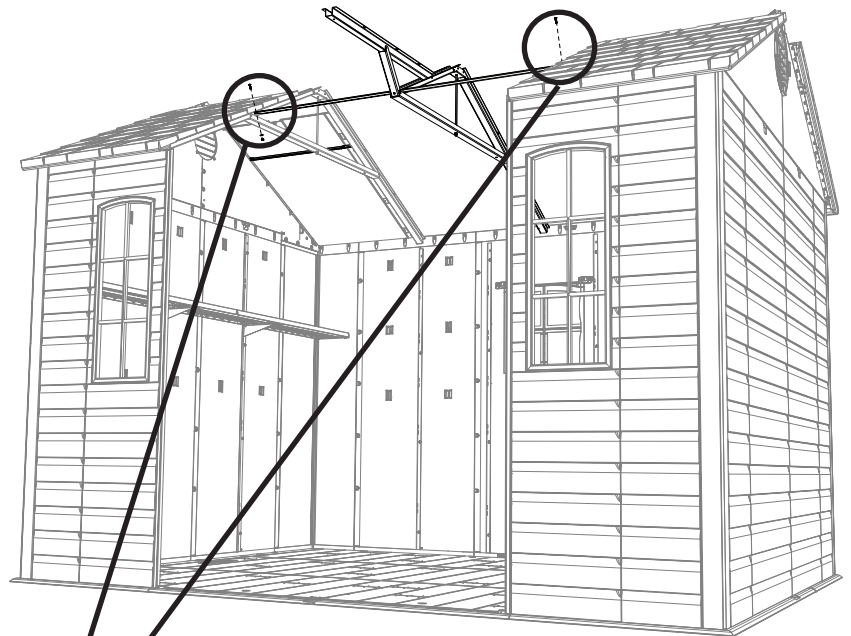

## ► SECTION 9 (CONTINUED) / SECTION 9 (SUITE) / SECCIÓN 9 (CONTINUACIÓN)

TOOLS AND HARDWARE REQUIRED / OUTILS ET QUINCAILLERIE REQUIS / INSTRUMENTAL Y HERRAJE REQUERIDOS



AHP (x2)

### 9.11



- Pull the hinge tube down out of the left door about six inches. Align the hole at the bottom of the hinge tube with the slit in the bushing, and insert the tube. Insert a **cotter pin (AHP)** and bend the ends.
- Étendre le tube d'articulation à peu près quinze centimètres du bord inférieur de la porte. Aligner le trou dans la partie inférieure du tube avec la fente dans la bague, et insérer le tube. Insérer une **clavette (AHP)** et plier les extrémités.
- Extender el tubo de articulación unos quince centímetros del borde inferior de la puerta. Alinee el agujero en la parte inferior del tubo con la rendija en el casquillo, e insertar el tubo. Insertar una **clavija (AHP)** y doble los extremos.

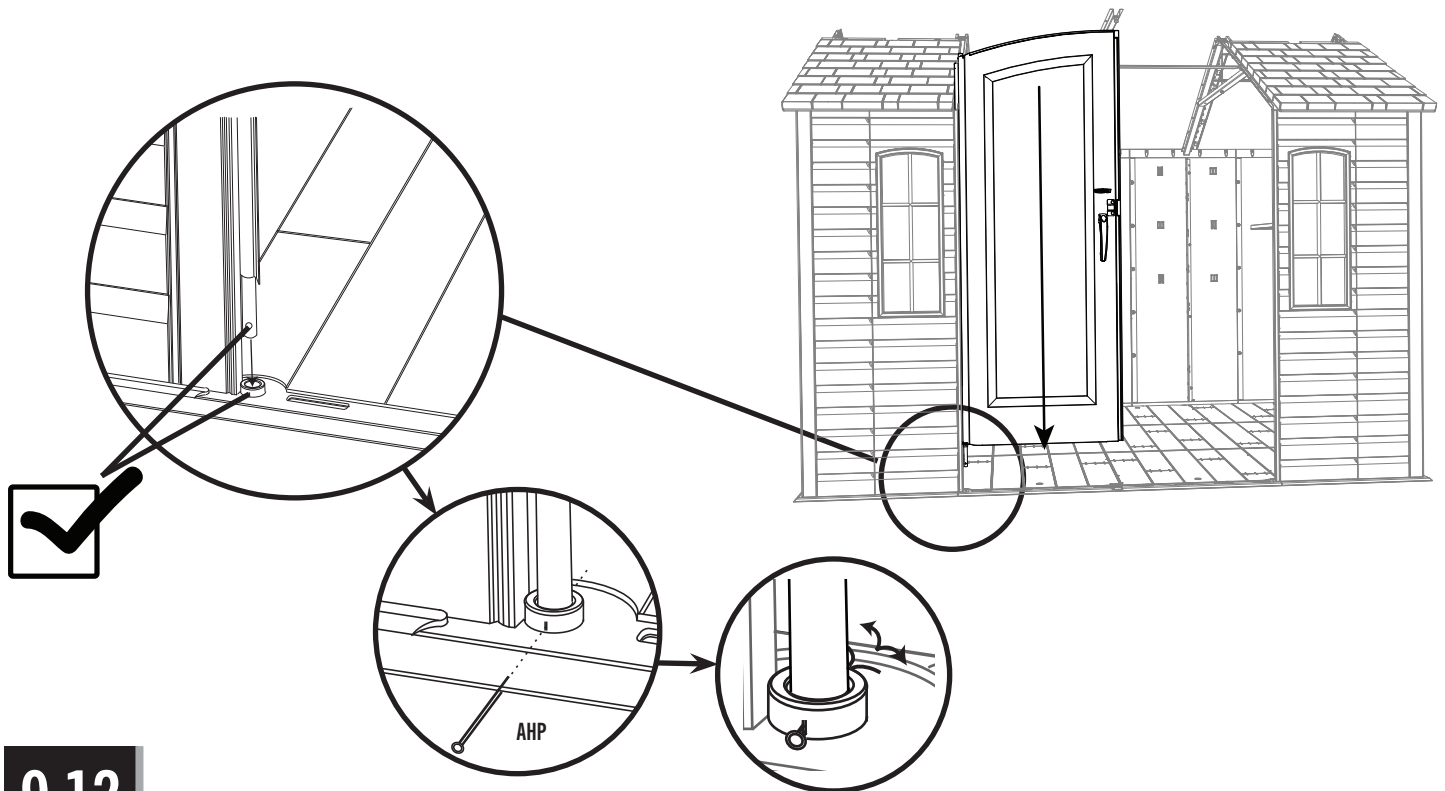

### 9.12



- Repeat this step for the right door.
- Répéter cette étape pour la porte droite.
- Repetir este paso para la puerta derecha.

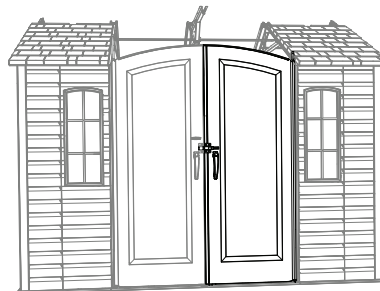

## ▶ SECTION 9 (CONTINUED) / SECTION 9 (SUITE) / SECCIÓN 9 (CONTINUACIÓN)

TOOLS AND HARDWARE REQUIRED / OUTILS ET QUINCAILLERIE REQUIS / INSTRUMENTAL Y HERRAJE REQUERIDOS

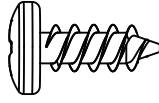

ADZ (x1)

### 9.13



- Slide the holes in the entry gable down over the two hinge tubes.
- Faire glisser les trous dans le pignon d'entrée sur les deux tubes.
- Deslizar los agujeros en la fachada de entrada sobre los dos tubos.

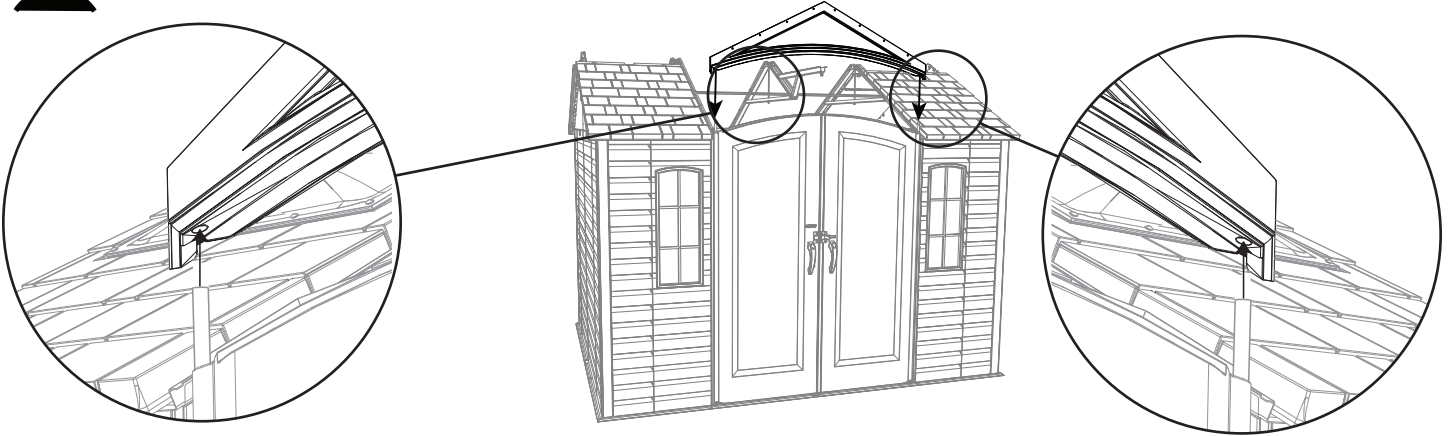

### 9.14

- Set the end of the center truss onto the notch in the front gable panel as shown.
- Mettre l'extrémité de la ferme centrale dans l'encoche dans la pignon avant comme indiqué.
- Colocar el extremo de la cercha central en la muesca en la fachada delantera como se muestra.

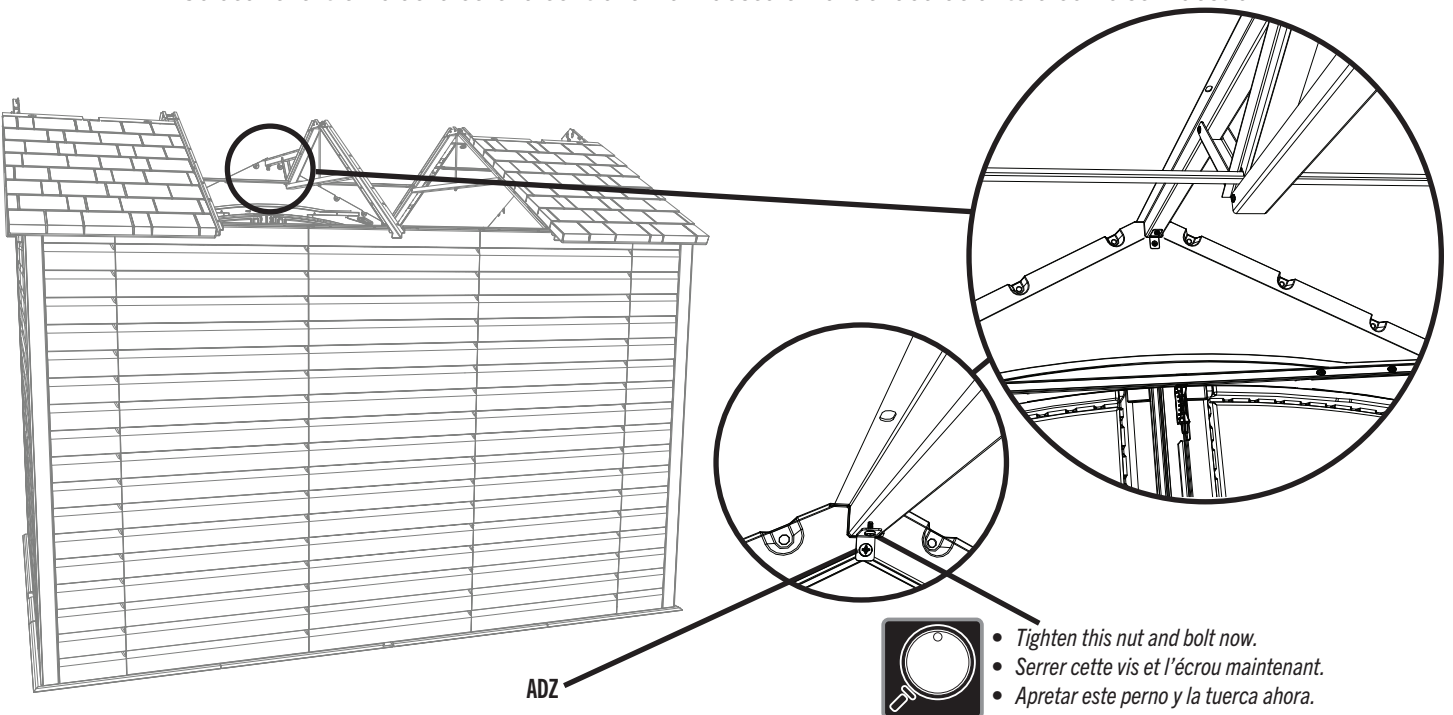

- Tighten this nut and bolt now.
- Serrer cette vis et l'écrou maintenant.
- Apretar este perno y la tuerca ahora.

## ► SECTION 9 (CONTINUED) / SECTION 9 (SUITE) / SECCIÓN 9 (CONTINUACIÓN)

TOOLS AND HARDWARE REQUIRED / OUTILS ET QUINCAILLERIE REQUIS / INSTRUMENTAL Y HERRAJE REQUERIDOS

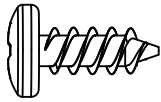

ADZ (x20)



ADK (x1)

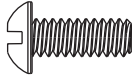

BZA (x1)

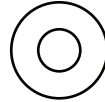

AEE (x2)

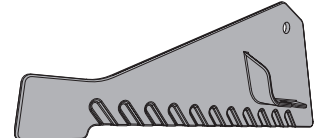

ECS (x1)

### 9.15

- Attach the two center, rear roof panels using only one roof support per panel.
- Attacher les deux panneaux de toit arrière centraux en utilisant un seul support de toit pour chaque panneau.
- Sujeter los dos paneles de tejado traseros centrales usando sólo un soporte de tejado por panel.

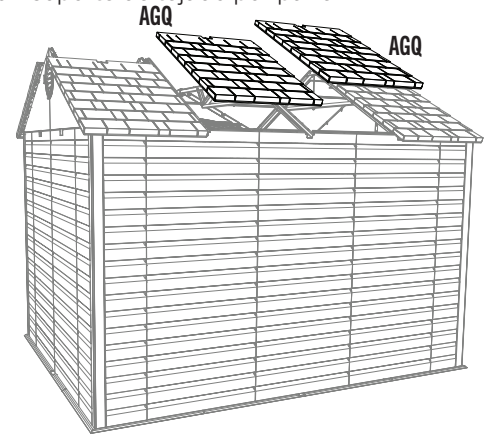

AFL (x2)

### 9.16

- Insert the **right drainage plate (ECS)** into the right lateral truss, and align the notch in the plate with the first hole in the truss as shown. Secure with the hardware provided.
- Insérer la **plaque de drainage droite (ECS)** dans la ferme latérale droite, et aligner l'encoche dans la plaque avec la premier trous dans la ferme comme indiqué. Bien l'attacher à la ferme à l'aide des accessoires inclus.
- Insertar la **placa derecha para el drenaje (ECS)** dentro de la cercha lateral derecho, y alinear la muesca en la placa con el primer agujero en la cercha. Sujetarla a la cercha usando el herraje incluido.

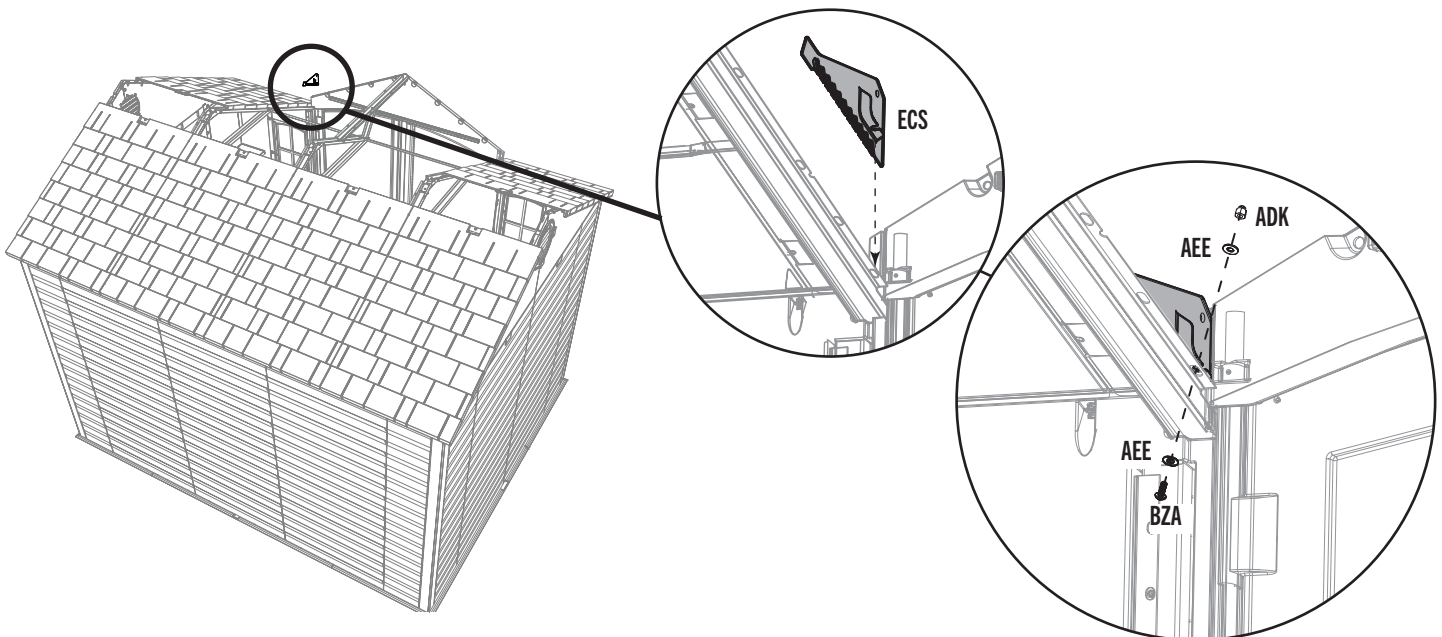



## SECTION 9 (CONTINUED) / SECTION 9 (SUITE) / SECCIÓN 9 (CONTINUACIÓN)

TOOLS AND HARDWARE REQUIRED / OUTILS ET QUINCAILLERIE REQUIS / INSTRUMENTAL Y HERRAJE REQUERIDOS

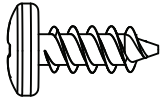

ADZ (x12)



ADK (x1)

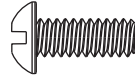

BZA (x1)

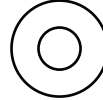

AEE (x2)

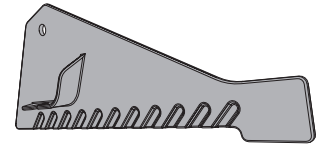

ECR (x1)

### 9.17



- Repeat the last step for the left drainage plate (ECR).
- Répéter l'étape précédente pour la plaque gauche de drainage (ECR).
- Repetir el paso anterior para la placa izquierda para el drenaje (ECR).

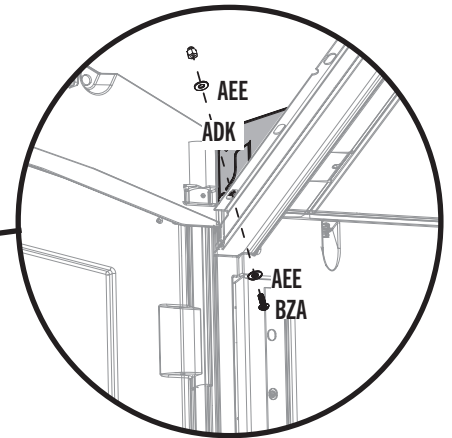
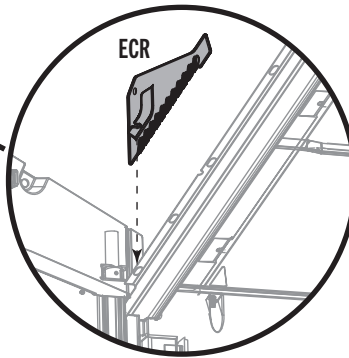
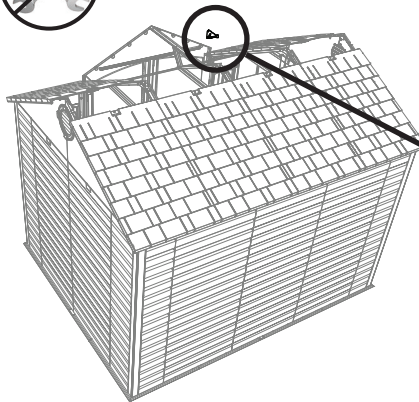

### 9.18

- Fold the ends of the **large angled roof panel (DRA)** and set it down onto the shed as shown. Secure the panel to the entry gable and center truss with twelve (12) screws (ADZ) at the locations shown.
- Plier les extrémités du **panneau de toit angulaire grand (DRA)** et le mettre sur l'abri comme indiqué. Bien l'attacher au pignon et à la ferme centrale à l'aide de douze (12) vis (ADZ) aux emplacements indiqués.
- Doblar los extremos del **panel de tejado angular grande (DRA)** y colocarlo en la caseta como se muestra. Sujeterlo a la fachada y la cercha central usando doce (12) tornillos (ADZ) a las ubicaciones indicadas.



- Fold these ends upward before installing.
- Plier ces rabats en haut avant d'installer.
- Doblar estas solapas hacia arriba antes de instalar.

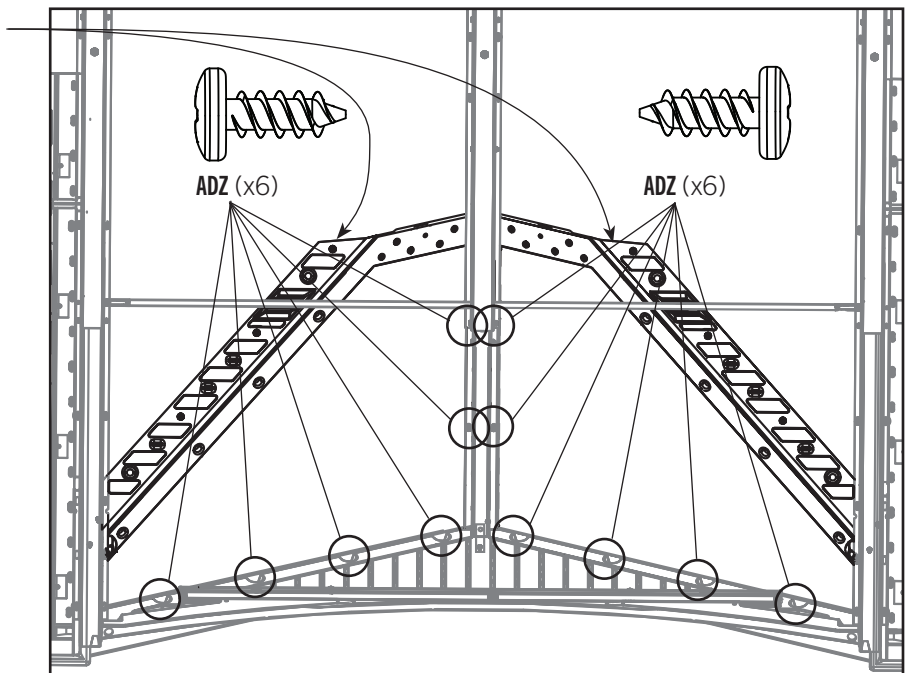
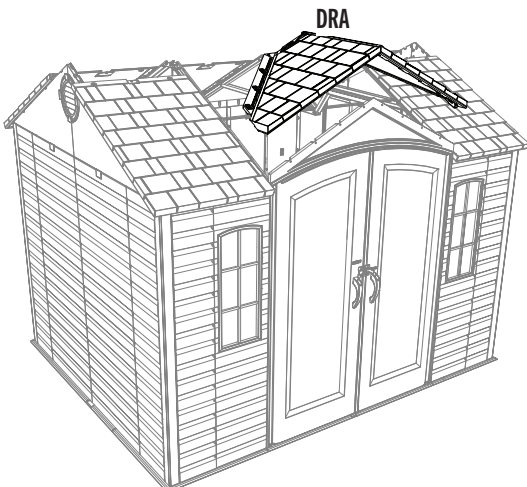

## ► SECTION 9 (CONTINUED) / SECTION 9 (SUITE) / SECCIÓN 9 (CONTINUACIÓN)

TOOLS AND HARDWARE REQUIRED / OUTILS ET QUINCAILLERIE REQUIS / INSTRUMENTAL Y HERRAJE REQUERIDOS

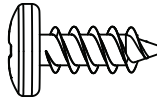
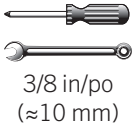

ADZ (x2)

### 9.19

- Secure the drainage plate from step 10.16 to the roof at the location shown. **Tighten the nut on the drainage plate now.**
- Attacher la plaque de drainage des étapes 10.16 au toit à l'emplacement indiqué. **Serrer l'écrou dans la plaque de drainage.**
- Sujetar la placa de drenaje de los pasos 10.16 al tejado a la ubicación indicada. **Apretar la tuerca en la placa de drenaje ahora.**

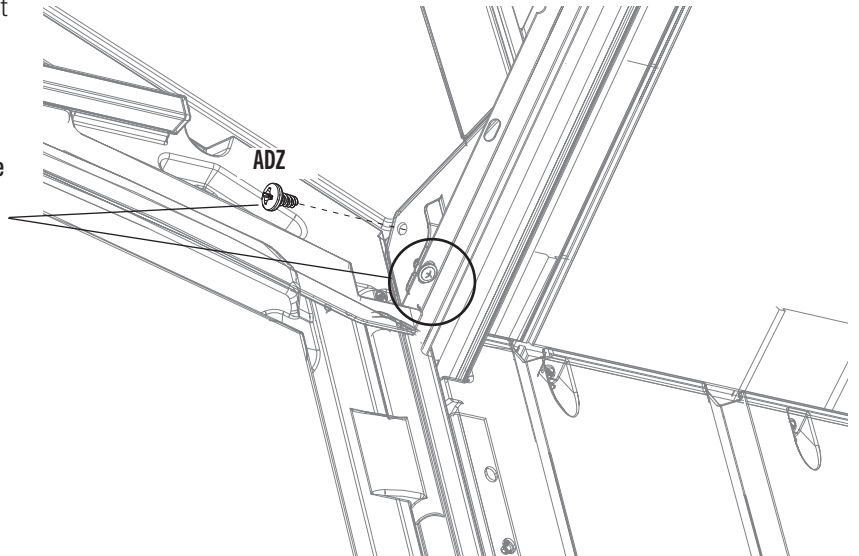

### 9.20

- Repeat the last step for the right drainage plate.
- Répéter l'étape précédente pour la plaque de drainage droite.
- Repetir el paso anterior para la placa de drenaje derecha.

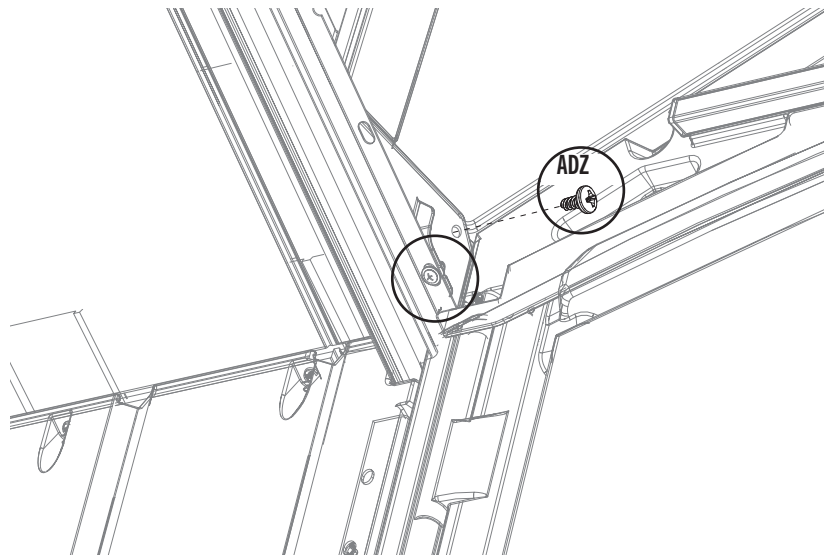

## ► SECTION 9 (CONTINUED) / SECTION 9 (SUITE) / SECCIÓN 9 (CONTINUACIÓN)

TOOLS AND HARDWARE REQUIRED / OUTILS ET QUINCAILLERIE REQUIS / INSTRUMENTAL Y HERRAJE REQUERIDOS

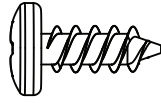

ADZ (x20)

### 9.21



- An adult must apply a downward pressure on **panel (DRB)** while another inserts these **screws (ADZ)**.
- Une adulte doit appliquer pression sur le **panneau (DRB)** en insérant les **vis (ADZ)**.
- Un adulto debe aplicar una presión de arriba en el **panel (DRB)** mientras la inserción de los  **tornillos (ADZ)**.

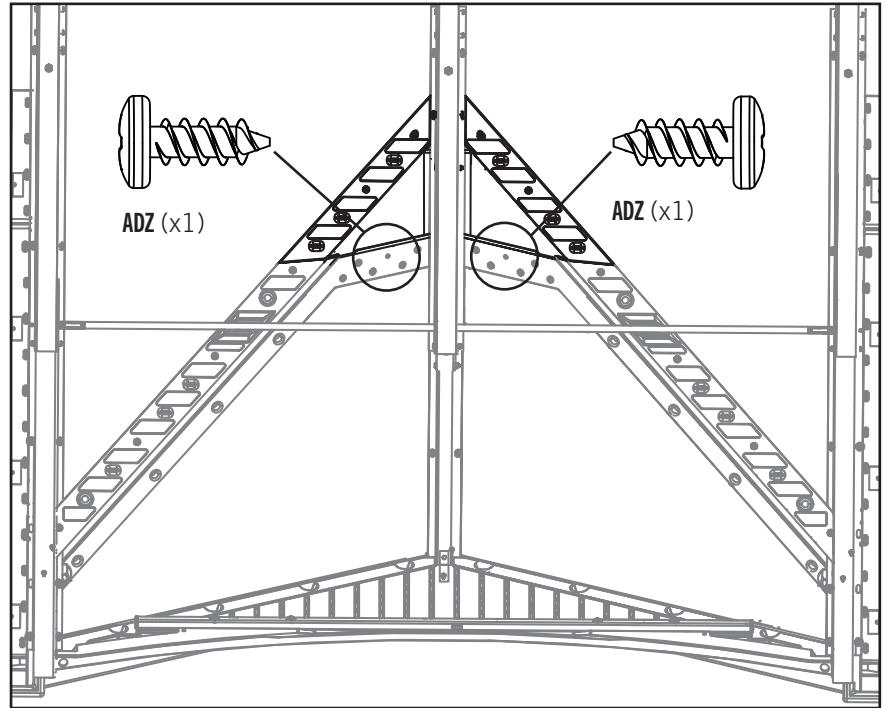
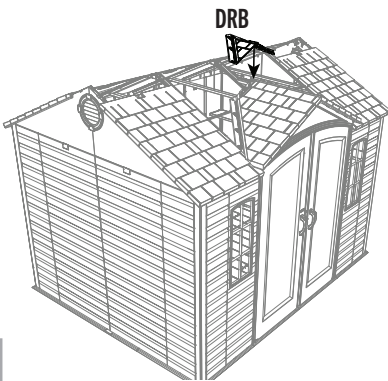

### 9.22



- An adult must apply a downward pressure on **panels (BDS & BDR)** while another inserts these **screws (ADZ)**.
- Une adulte doit appliquer pression sur les **panneaux (BDS et BDR)** en insérant les **vis (ADZ)**.
- Un adulto debe aplicar una presión de arriba en los **paneles (BDS y BDR)** mientras la inserción de los **tornillos (ADZ)**.

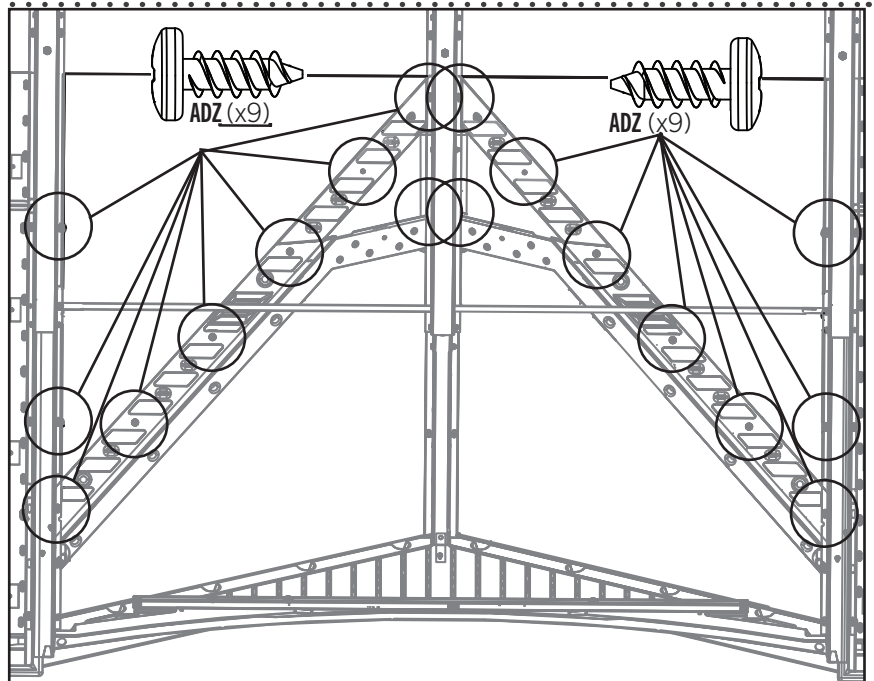
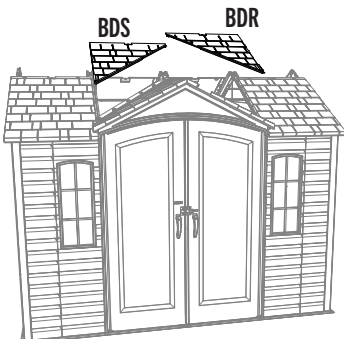

## ► SECTION 9 (CONTINUED) / SECTION 9 (SUITE) / SECCIÓN 9 (CONTINUACIÓN)

TOOLS AND HARDWARE REQUIRED / OUTILS ET QUINCAILLERIE REQUIS / INSTRUMENTAL Y HERRAJE REQUERIDOS

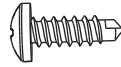

BHJ (x2)

### 9.23

- Use an electric screwdriver to insert a **self-tapping screw (BHJ)** through the plastic of the gable and into the right and left door hinge tubes at the location shown.
- Employer un perceuse électrique pour insérer une **vis autotaraudeuse (BHJ)** à travers le pignon et dans les charnières des portes aux emplacements indiqués.
- Utilizar un taladro eléctrico para introducir un  **tornillo auto-roscante (BHJ)** a través la fachada y dentro de las bisagras derecha e izquierda a las ubicaciones indicadas.

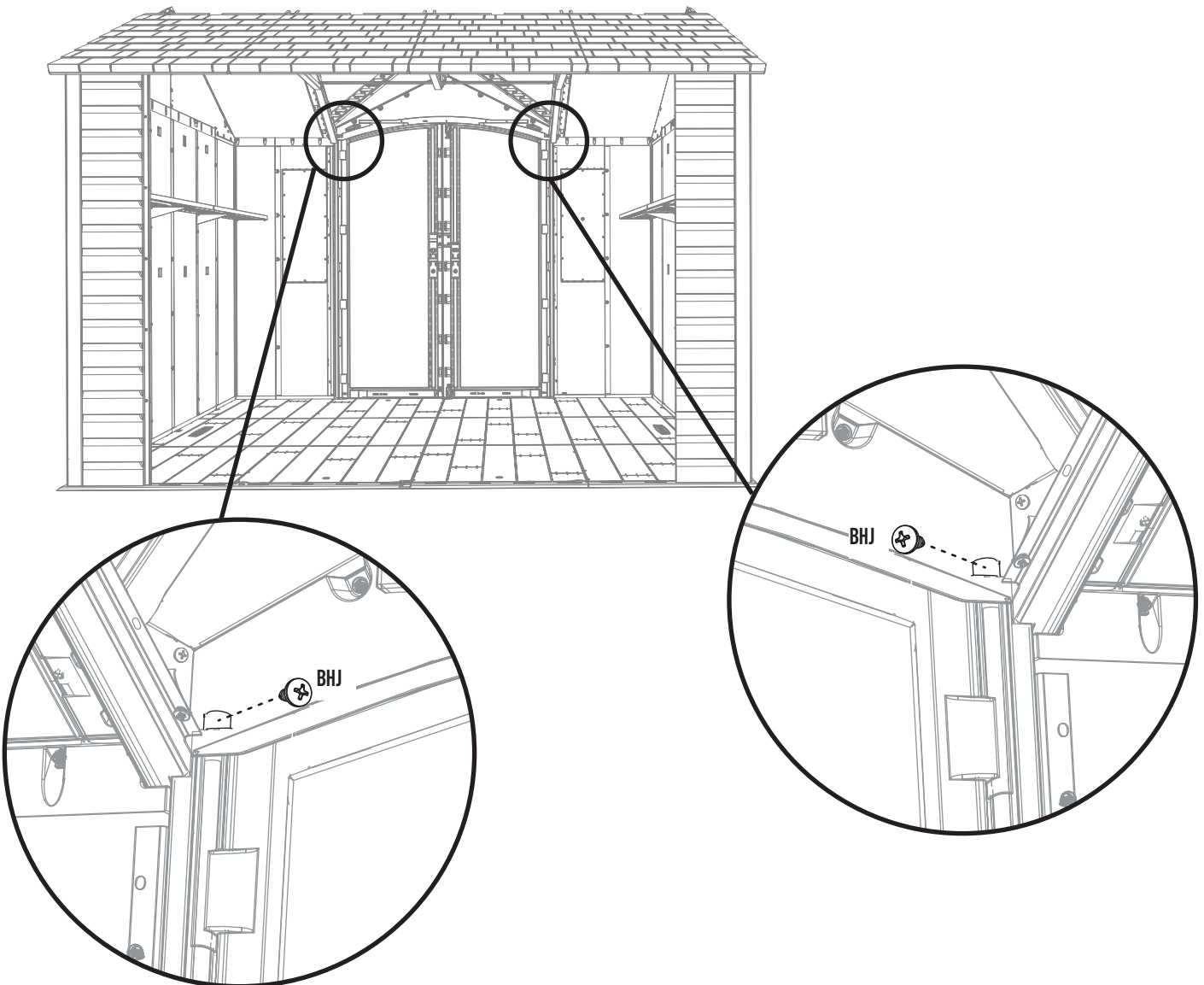

## ► SECTION 9 (CONTINUED) / SECTION 9 (SUITE) / SECCIÓN 9 (CONTINUACIÓN)

TOOLS AND HARDWARE REQUIRED / OUTILS ET QUINCAILLERIE REQUIS / INSTRUMENTAL Y HERRAJE REQUERIDOS

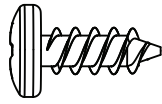

ADZ (x28)

### 9.24

- Starting at the right, attach the roof caps to the shed using the hardware provided.
- En commençant au côté droit, attacher les chapeaux à l'abri à l'aide de la quincaillerie incluse.
- Empezando al lado derecho, sujetar las cumbreras a la caseta usando el herraje incluido.

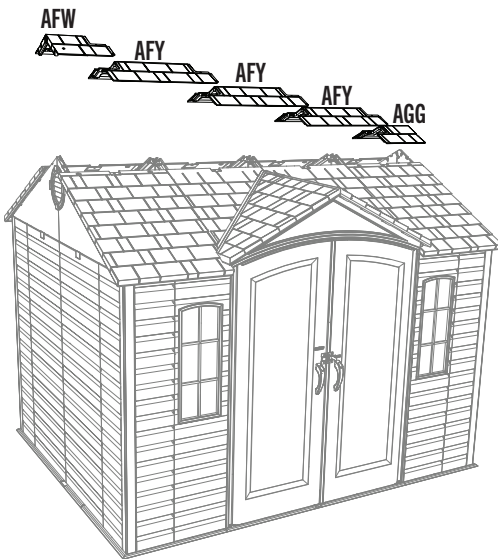

- The ends of the roof caps overlap one another.
- Les extrémités des chapeaux se chevauchent.
- Los extremos de las cumbreras se solapan.

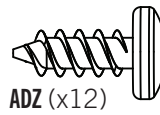

ADZ (x12)

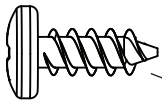

ADZ (x8)

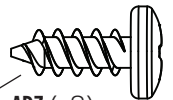
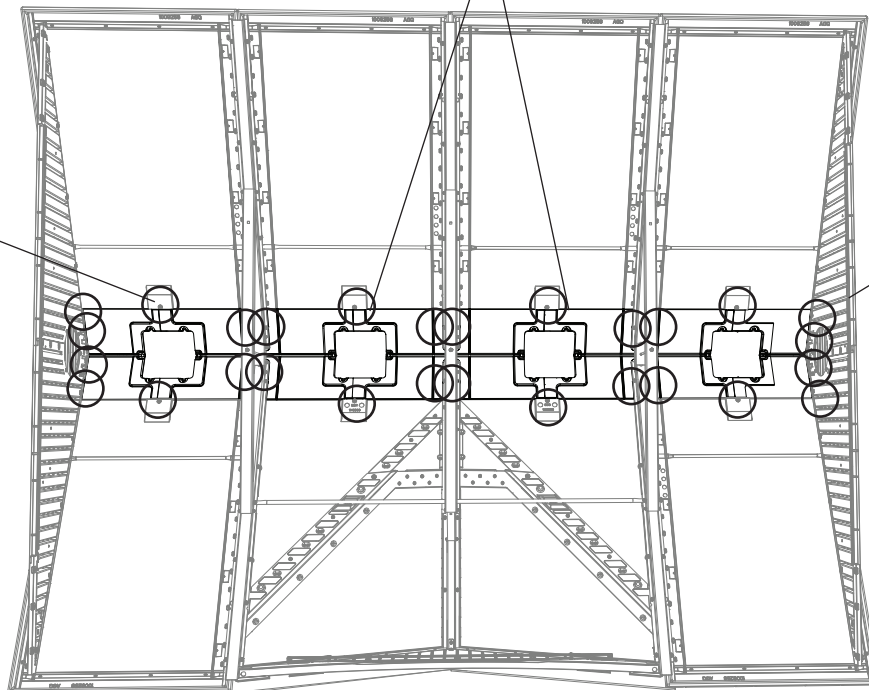

ADZ (x8)

## ► SECTION 9 (CONTINUED) / SECTION 9 (SUITE) / SECCIÓN 9 (CONTINUACIÓN)

TOOLS AND HARDWARE REQUIRED / OUTILS ET QUINCAILLERIE REQUIS / INSTRUMENTAL Y HERRAJE REQUERIDOS

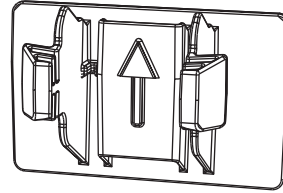
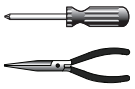

AXX (x4)

### 9.25

- Fold the **skylights (AHC)**, and attach them to the roof using six (6) **screws (ADX)** and **washers (AED)** for each skylight.
- Plier les **lucarnes (AHC)**, et les attacher au toit à l'aide de six (6) **vis (ADX)** et **rondelles (AED)** pour chaque lucarne.
- Doblar los **tragaluzes (AHC)**, y sujetarlos al tejado usando seis (6) **tornillos (ADX)** y **rondanas (AED)** para cada tragaluz.



AHC AHC AHC AHC

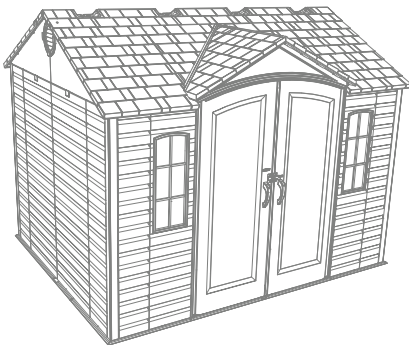

AHC

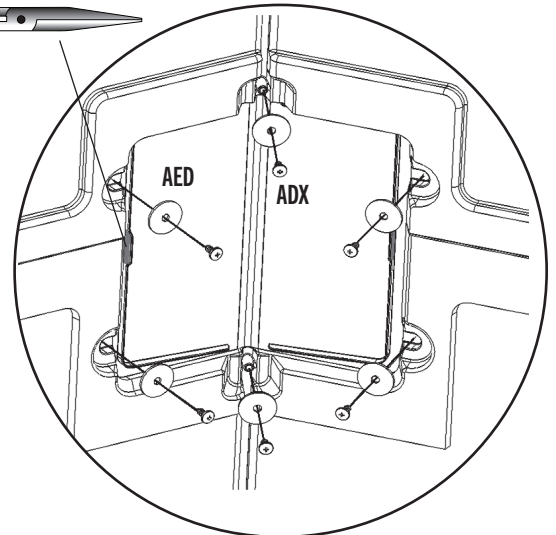
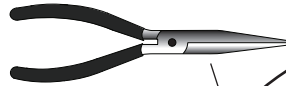
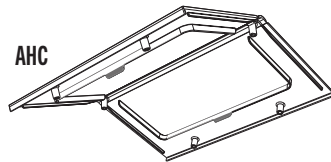

### 9.26

- Insert the **clips (AXX)** with the "arrow" facing up.
- Insérer les **clips (AXX)** avec la « flèche » vers le haut.
- Insertar los **clips (AXX)** con la « flecha » hacia arriba.

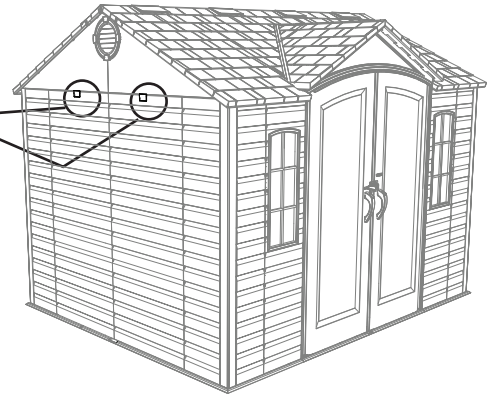
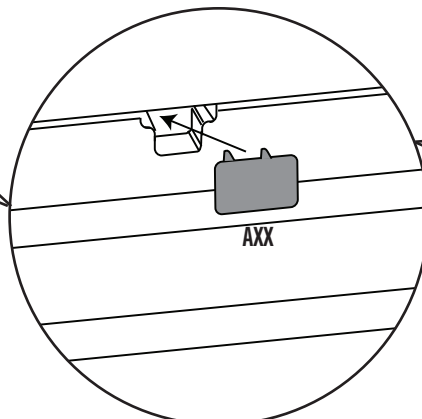
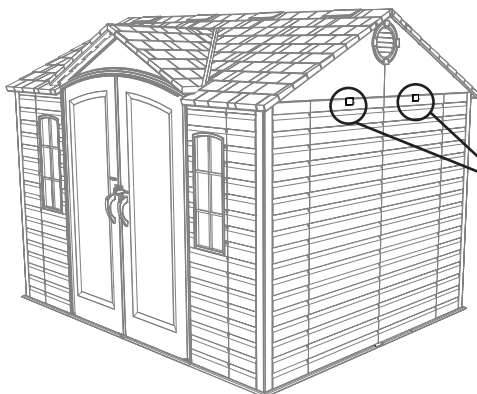
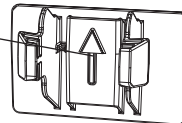

# 10

## DOOR ALIGNMENT / ALIGNEMENT DES PORTES / ALINEACIÓN DE LAS PUERTAS



### HARDWARE REQUIRED / QUINCAILLERIE REQUISE / HERRAJE REQUERIDO



### PARTS REQUIRED / PIÈCES REQUISES / PIEZAS REQUERIDAS

Wood parts / Pièces en bois / Piezas de madera

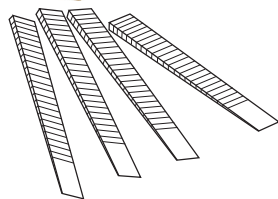

AIX (x4)



### TOOLS REQUIRED / OUTILS REQUIS / INSTRUMENTAL REQUERIDO

(Not included—unless otherwise indicated\*) / (Non inclus — sauf indication contraire\*) / (No incluido, salvo indicación contraria\*)



## ► SECTION 10 (CONTINUED) / SECTION 10 (SUITE) / SECCIÓN 10 (CONTINUACIÓN)

TOOLS AND PARTS REQUIRED / OUTILS ET PIÈCES REQUIS / INSTRUMENTAL Y HERRAJE REQUERIDOS



- In case of any trouble with this section, scan the QR code below to view a video on its assembly.
- En cas de problème avec cette section, scanner le QR code en dessous pour voir une vidéo de l'assemblage.
- En caso de problemas con esta sección, escanear el código QR debajo para ver un video del ensamblaje.



<http://go.lifetime.com/10x8-section10>

### 10.1

- If the doors are not level, follow the steps on this page or the next to even them out.
- Si les portes ne sont pas niveau l'une avec l'autre, suivre les étapes dans cette page ou la suivante pour les niveler.
- Si las puertas no están niveladas, seguir los pasos en esta página o la siguiente para nivelarlas.

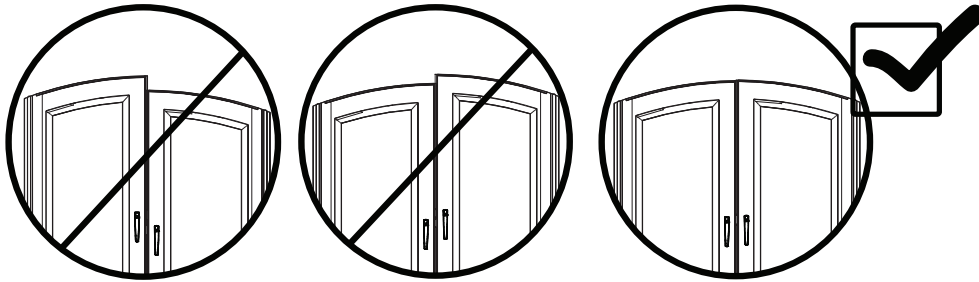

### 10.1.1

- If the left door is higher, insert a **shim (AIX)** underneath floor and the right hinge tube until the doors are the same height. **Break off any excess shim.**
- Si la porte gauche est plus haute, insérer une **cale (AIX)** sous le plancher et le tube d'articulation de la porte droite jusqu'à ce que les portes restent à la même hauteur. **Détacher de l'excès des cales.**
- Si la puerta izquierda es más alta, insertar una **cuña (AIX)** debajo el piso y el tubo de articulación de la puerta derecha hasta que las puertas queden a la misma altura. **Quebrantar cualquier exceso de las cuñas.**

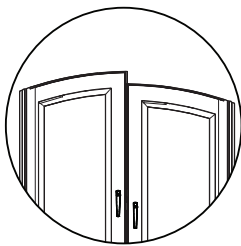

1

+

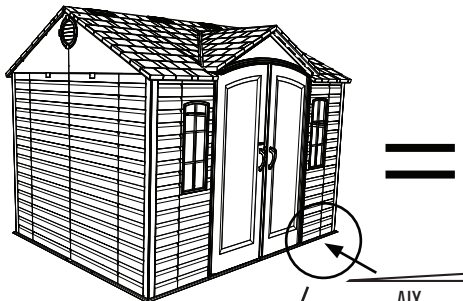

2

=

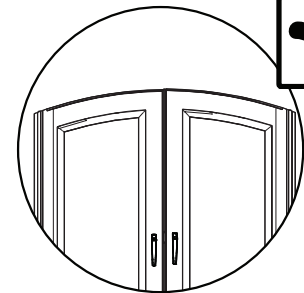

3

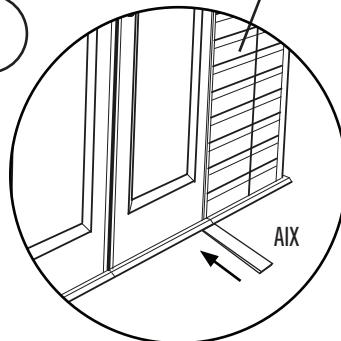



## ► SECTION 10 (CONTINUED) / SECTION 10 (SUITE) / SECCIÓN 10 (CONTINUACIÓN)

TOOLS AND PARTS REQUIRED / OUTILS ET PIÈCES REQUIS / INSTRUMENTAL Y HERRAJE REQUERIDOS



### 10.1.2

- If the right door is higher, insert a **shim (AIX)** underneath the floor and hinge tube of the left door until the doors are the same height. **Break off any excess shim.**
- Si la porte droite est plus haute, insérer une **cale (AIX)** sous le plancher et le tube d'articulation de la porte gauche jusqu'à ce que les portes restent à la même hauteur. **Détacher de l'excès des cales.**
- Si la puerta derecha es más alta, insertar una **cuña (AIX)** debajo el piso y tubo de articulación de la puerta izquierda hasta que las puertas queden a la misma altura. **Quebrantar cualquier exceso de las cuñas.**

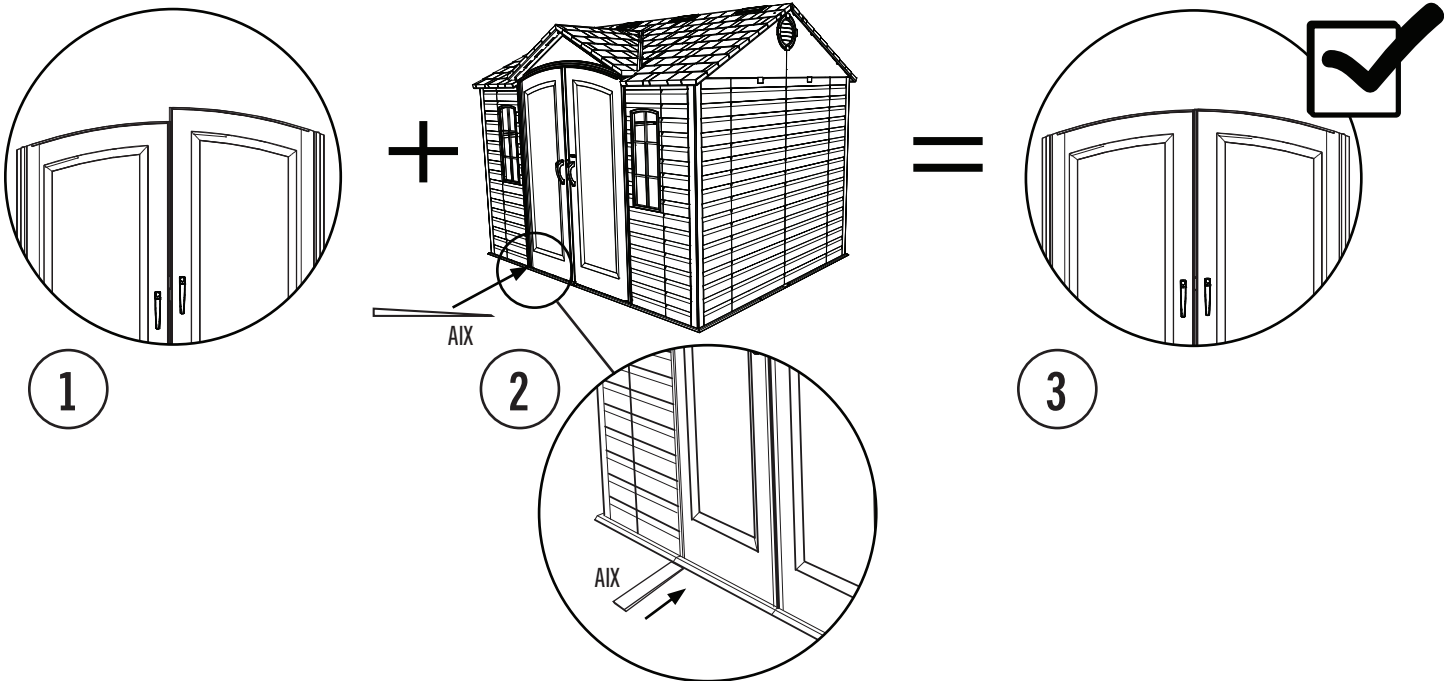

# 11

## SHED ANCHORING / ANCRAGE DE L'ABRI / ANCLAJE DE LA CASETA



### HARDWARE REQUIRED / QUINCAILLERIE REQUISE / HERRAJE REQUERIDO



### PARTS REQUIRED / PIÈCES REQUISES / PIEZAS REQUERIDAS



### TOOLS REQUIRED / OUTILS REQUIS / INSTRUMENTAL REQUERIDO

*(Not included—unless otherwise indicated\*) / (Non inclus — sauf indication contraire\*) / (No incluido, salvo indicación contraria\*)*

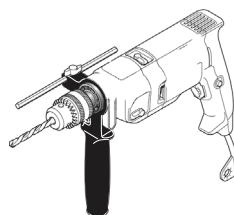

5/16 in/po (≈8 mm) Wood drill bit  
5/16 in/po (≈8 mm) Broca para madera  
5/16 in/po (≈8 mm) Foret à boit



5/16 in/po (≈8 mm) Masonry drill bit  
5/16 in/po (≈8 mm) Broca para albañilería  
5/16 in/po (≈8 mm) Foret à maçonnerie

## ► SECTION 11 (CONTINUED) / SECTION 11 (SUITE) / SECCIÓN 11 (CONTINUACIÓN)

TOOLS AND PARTS REQUIRED / OUTILS ET PIÈCES REQUIS / INSTRUMENTAL Y HERRAJE REQUERIDOS

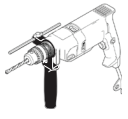

5/16 in/po  
(≈8 mm)



### 11.1



- To anchor your shed, you must purchase the correct anchoring hardware. **For a concrete platform**, we recommend using a hammer drill, 5/16" (≈8 mm) masonry bit, eight (8) 3/8" x 2" (≈10 mm x ≈5 cm) Concrete Screws and eight (8) 3/8" x 1" (≈10 mm x ≈2,5 cm) Fender Washers. **Do not exceed a 3/8" (≈10 mm) diameter screw. Refer to your local hardware store for this hardware.**
- Pour ancrer l'abri, il faut acheter la quincaillerie d'ancrage correcte. **Pour une plate-forme en béton**, nous recommandons que vous utilisiez une perceuse de percussion, un foret à maçonnerie de 5/16 po (≈8 mm), huit (8) vis d'ancrage à béton de 3/8 po x 2 po (≈10 mm x ≈5 cm) et huit (8) rondelles de protection de 3/8 po x 1 po (≈10 mm x ≈2,5 cm). **Ne dépassez pas un diamètre de 3/8 po (≈10mm). Votre quincaillerie du coin aura ces accessoires.**
- Para anclar la caseta, es necesario comprar el herraje de anclaje correcto. **Para una plataforma de concreto**, recomendamos que use un martillo perforador, broca de albañilería de 5/16 in (≈8 mm), ocho (8) tornillos de anclaje para concreto de 3/8 in x 2 in (≈10 mm x ≈5 cm) y ocho (8) rondanas de protección de 3/8 in x 1 in (≈10 mm x ≈2,5 cm). **No exceda un diámetro de 3/8 in (≈10 mm). Refiérase a su ferretería local para obtener este herraje.**

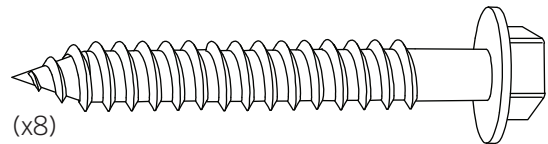
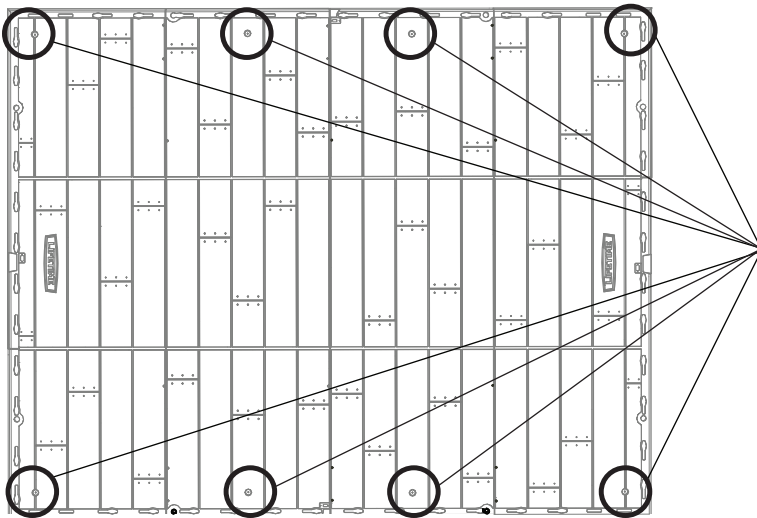

(x8)

(Not included) (Pas incluses) (No incluidos)

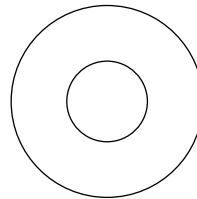

(x8)

(Not included) (Pas incluses) (No incluidas)



### WARNING / AVERTISSEMENT / ADVERTENCIA



- Failure to anchor the shed may result in property damage and/or personal injury.
- Si vous n'ancrez pas votre abri, des dommages à la propriété et/ou des blessures peuvent en résulter.
- No anclar la caseta puede resultar en daños a la propiedad y/o en lesiones personales.

## ▶ SECTION 11 (CONTINUED) / SECTION 11 (SUITE) / SECCIÓN 11 (CONTINUACIÓN)

TOOLS AND PARTS REQUIRED / OUTILS ET PIÈCES REQUIS / INSTRUMENTAL Y HERRAJE REQUERIDOS



5/16 in/po  
(≈8 mm)



# 11.1



- To anchor your shed, you must purchase the correct anchoring hardware. **For a wood-framed platform**, we recommend using a drill, 5/16" (8 mm) drill bit, eight (8) 3/8" x 1 1/2" (10 mm x 4 cm) Lag Screws and eight (8) 3/8" x 1" (10 mm x 2,5 cm) Fender Washers. **Do not exceed a 3/8" diameter screw. Refer to your local hardware store for this hardware.**
- Pour ancrer l'abri, il faut acheter la quincaillerie d'ancrage correcte. **Pour une plate-forme en bois**, nous recommandons que vous utilisiez une perceuse électrique, un foret de 5/16 po (≈8 mm), huit (8) vis de retard de 3/8 po x 1 1/2 po (≈10 mm x ≈4 cm), et huit (8) rondelles de protection de 3/8 po x 1 po (≈10 mm x ≈2,5 cm). **Ne dépassez pas un diamètre de 3/8 po (≈10 mm). Votre quincaillerie du coin aura ces accessoires.**
- Para anclar la caseta, es necesario comprar el herraje de anclaje correcto. **Para una plataforma hecho de madera**, recomendamos que use un taladro eléctrico, una broca de 5/16 in (≈8 mm), ocho (8) Tornillos para madera de 3/8 in x 1 1/2 in (≈10 mm x ≈4 cm) y ocho (8) Rondanas de protección de 3/8 in x 1 in (≈10 mm x ≈2,5 cm). **No exceda un diámetro de 3/8 in (≈10 mm). Refiérase a su ferretería local para obtener este herraje.**

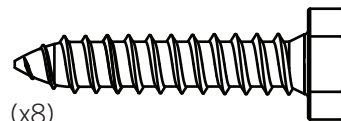
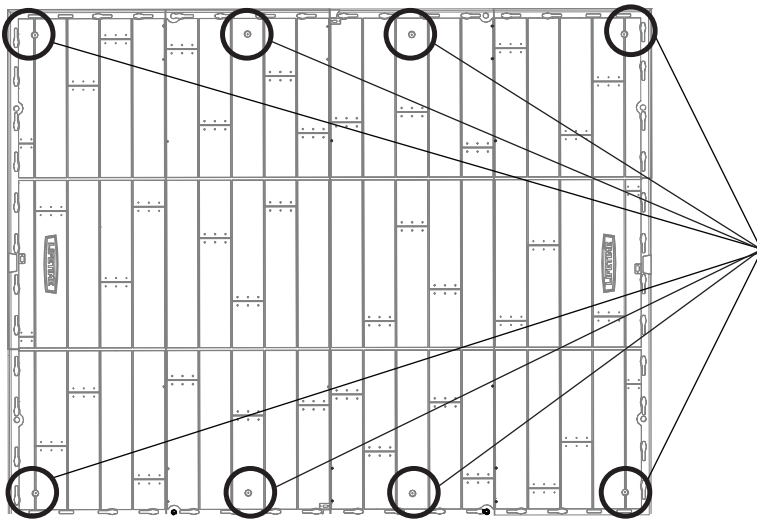

(x8)

(Not included) (Pas incluses) (No incluidos)

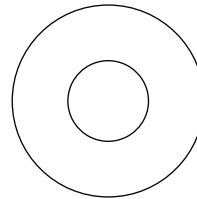

(x8)

(Not included) (Pas incluses) (No incluidas)



### WARNING / AVERTISSEMENT / ADVERTENCIA



- Failure to anchor the shed may result in property damage and/or personal injury.
- Si vous n'ancrez pas votre abri, des dommages à la propriété et/ou des blessures peuvent en résulter.
- No anclar la caseta puede resultar en daños a la propiedad y/o en lesiones personales.

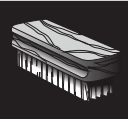

## CLEANING & CARE

**Congratulations on your Lifetime® product purchase. By following the instructions below, your new Lifetime product should provide you with years of service and enjoyment.**

The polyethylene panels are stain and solvent resistant. Most stains can be removed using a mild soap and a soft-bristled brush. Abrasive cleaning materials may scratch the plastic and are not recommended. Repair scratches or rust spots on the metal by sanding the affected area lightly; using a rust preventative spray primer; and finally, spraying with a high-gloss spray enamel paint. Avoid placing a direct heat source on or near surfaces unless using a heat barrier.

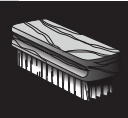

## NETTOYAGE ET ENTRETIEN

**Nous vous félicitons d'avoir acheté ce produit Lifetime®. En suivant les instructions ci-dessous, votre nouveau produit Lifetime devrait vous fournir des années de service et de plaisir.**

Les murs et les étagères en polyéthylène sont résistants aux taches et solvants de nettoyage. Pour les nettoyer, se servir d'un savon doux et d'une brosse douce. Les produits abrasifs de nettoyage risquent d'égratigner le plastique et ne sont pas recommandés. Pour réparer les égratignures ou taches de rouille sur le métal, frotter légèrement l'endroit affecté au papier de verre, puis passer une couche de produit vaporisant préventif, et, enfin, vaporiser une peinture émail ultrabrillante. Éviter de placer une source de chaleur directe sur ou près des surfaces, ou les protéger à l'aide d'une protection contre la chaleur.



## LIMPIEZA Y CUIDADO

**Felicidades por la compra de su producto Lifetime®. Al seguir las siguientes instrucciones, su nuevo producto Lifetime le brindará años de servicio y satisfacción.**

Los paneles de polietileno son resistentes a las manchas y solventes. La mayoría de las manchas puede removerse usando un jabón suave y un cepillo de cerdas suaves. Los materiales abrasivos para limpieza pueden rayar el plástico y no se recomiendan. Reparar rayones o manchas de óxido en el metal, lijando suavemente la parte afectada; usando un aerosol preventivo de óxido y finalmente, rociando con una pintura de esmalte brillante. Evitar poner una fuente de calor directa en o cerca de las superficies sin usar una barrera de calor.



## REGISTER YOUR PRODUCT ONLINE AT WWW.LIFETIME.COM

At Lifetime®, we are committed to providing innovative and quality products. While registering, you will have the opportunity to give us your feedback. Your input is valuable to us.

- You can also opt in to receive new product notifications or promotions.
- In the unlikely event of a product recall or safety modification, your registration provides the information we need to notify you directly.
- Registration is fast, easy, and completely voluntary.

### LIFETIME'S PROMISE TO YOU:

*Maintaining your privacy is our long-standing policy at Lifetime®. And you can rest assured that Lifetime® will not sell or provide your personal data to other third parties, or allow them to use your personal data for their own purposes.*

We invite you to read our privacy policy at [www.lifetime.com](http://www.lifetime.com)

**REGISTER today!**



## ENREGISTRER CE PRODUIT EN LIGNE À WWW.LIFETIME.COM

Chez Lifetime®, nous nous engageons à fournir des produits innovateurs de qualité. Lors de votre inscription, vous aurez l'occasion de nous faire parvenir vos commentaires. Votre opinion est importante pour nous.

- On peut également choisir de recevoir des avis ou des promotions dans le cadre de nouveaux produits.
- Dans l'éventualité improbable d'un rappel ou d'un avis de sécurité, l'inscription fournit les renseignements nécessaires nous permettant de communiquer avec vous.
- L'inscription est rapide, facile et complètement volontaire.

### LA PROMESSE DE LIFETIME:

*Conserver votre confidentialité est notre politique de longue date chez Lifetime®. Vous pouvez donc être rassuré par le fait que Lifetime® ne vendra pas ou ne fournira pas vos données personnelles à des tiers, et ne leur permettra pas d'utiliser vos données personnelles à leurs propres fins.*

Nous vous invitons à lire notre politique de confidentialité à [www.lifetime.com](http://www.lifetime.com) (en anglais seulement)

**ENREGISTRER CE PRODUIT aujourd'hui!**



## REGISTRAR EL PRODUCTO EN LÍNEA EN WWW.LIFETIME.COM

En Lifetime®, estamos comprometidos a ofrecer productos innovadores y de calidad. Al registrarse, usted tendrá la oportunidad de darnos su retroalimentación. Su información es valiosa para nosotros.

- También puede optar por recibir nuestras notificaciones o promociones.
- En el caso improbable de que el producto deba ser retirado del mercado o que sufra alguna modificación, su registro provee la información que necesitamos para notificarle directamente.
- El registro es rápido, fácil y completamente voluntario.

### LA PROMESA DE LIFETIME® PARA USTED:

*Mantener privacidad es nuestra política permanente en Lifetime®. Y puede estar seguro que Lifetime® no venderá ni dará datos personales a terceros, ni les permitirá usar datos personales para sus propios fines.*

Lo invitamos a leer nuestra política de privacidad en [www.lifetime.com](http://www.lifetime.com) (sólo en inglés)

**¡REGISTRARSE hoy mismo!**



## 10-YEAR LIMITED FACTORY WARRANTY

**THE MANUFACTURER RESERVES THE RIGHT TO MAKE SUBSTITUTIONS TO WARRANTY CLAIMS IF PARTS ARE UNAVAILABLE OR OBSOLETE.**

Lifetime Lawn and Garden products are warranted to the original purchaser to be free from defects in material or workmanship for a period of 10 years from the date of original retail purchase. The word “defects” is defined as imperfections that impair the use of the product. Defects resulting from misuse, abuse or negligence will void this warranty. This warranty does not cover defects due to improper installation, alteration or accident. Lifetime recommends that no modifications be made to this product. This warranty does not cover damage caused by vandalism, rusting, “acts of nature”, natural disasters, normal wear and tear, or any other event beyond the control of the manufacturer.

This warranty is nontransferable and is expressly limited to the repair or replacement of defective products. If the product is defective within the terms of this warranty, Lifetime Products, Inc. will repair or replace defective parts at no cost to the purchaser. Shipping charges to and from the factory or distribution center are not covered and are the responsibility of the purchaser. Labor charges and related expenses for removal, installation or replacement of the product or its components are not covered under this warranty.

This warranty does not cover scratching, scuffing, or other cosmetic damage of the product that may result from normal usage. In addition, defects resulting from intentional damage, negligence, or unreasonable use will void this warranty / are not covered by this warranty.

Liability for incidental or consequential damages is excluded to the extent permitted by law. All merchandise is sold on this condition, and no representative of the company may waive or change this policy. This product is not intended for institutional or commercial use; Lifetime Products, Inc. does not assume any liability for such use. Institutional or commercial use will void the warranty.

This warranty is expressly in lieu of all other warranties, expressed or implied, including warranties of merchantability or fitness for use to extent permitted by Federal and state law. Neither Lifetime Products, Inc., nor any representative assumes any other liability in connection with this product. This warranty gives you specific legal rights, and you may also have other rights which vary from state to state.

AUSTRALIA : Our goods come with guarantees that cannot be excluded under the Australian Consumer Law. You are entitled to a replacement or refund for a major failure and for compensation for any other reasonably foreseeable loss or damage. You are also entitled to have the goods repaired or replaced if the goods fail to be of acceptable quality and the failure does not amount to a major failure.

**ALL WARRANTY CLAIMS MUST BE ACCOMPANIED BY A SALES RECEIPT.  
REPORT PRODUCT DEFECTS IN WRITING TO:**

LIFETIME PRODUCTS, INC.,  
PO Box 160010  
Freeport Center, Bldg. D-12  
Clearfield, UT 84016-0010

For online warranty claims, please visit: [www.lifetime.com/warranty](http://www.lifetime.com/warranty)  
Warranty Department: (800) 225-3865

**FOR INTERNATIONAL WARRANTY:**

All warranty claims must be accompanied by a sales receipt. Report product defects in writing to your regional sales support representative. Please include your dated sales receipt and photographs of damaged parts.

To Identify the representative for your region, please visit: [www.lifetime.com/international](http://www.lifetime.com/international)



## GARANTIE DE FABRICATION LIMITÉE DE 10 ANS

**LIFETIME® PRODUCTS, INC. RÉSERVE LE DROIT DE FAIRE DES SUBSTITUTIONS EN CAS DE RECOURS EN GARANTIE SI LES PIÈCES NE SONT PAS DISPONIBLES OU SONT OBSOLÈTES.**

L'acheteur d'origine des produits pour pelouses et jardins de Lifetime bénéficie d'une garantie contre toute défectuosité de matériel et de fabrication pour une période de 10 ans à compter de la date d'achat. On entend par « défaut » une imperfection qui nuit à l'utilisation du produit. Tout défaut découlant d'une mauvaise utilisation, d'un abus ou d'une négligence a pour effet d'annuler cette garantie. Cette garantie ne couvre pas les défauts attribuables à une installation inadéquate, une altération ou un accident. Lifetime recommande de ne pas apporter de modifications à ce produit. Cette garantie ne couvre pas les dommages causés par le vandalisme, la corrosion par la rouille, les cas de « force majeure », les catastrophes naturelles, la détérioration et l'usure normales et tout autre événement indépendant de la volonté du fabricant.

Cette garantie n'est pas transférable et se limite expressément à la réparation ou au remplacement d'un produit défectueux. Si le produit est défectueux au sens de cette garantie, Lifetime Products, Inc. réparera ou remplacera les pièces défectueuses sans frais pour l'acheteur. Les frais d'expédition en partance ou en provenance de l'usine ou du centre de distribution ne sont pas couverts et incombent à l'acheteur. Les coûts relatifs à la main-d'œuvre et les autres frais liés au retrait, à l'installation ou au remplacement du produit ou de ses composants ne sont pas couverts par cette garantie.

Cette garantie ne couvre pas les rayures, les égratignures ou autres dommages esthétiques du produit découlant d'un usage normal. De plus, tout défaut découlant d'un dommage volontaire, de négligence ou d'un usage déraisonnable annule cette garantie et n'est pas couvert par cette garantie.

Dans la mesure permise par la loi, la société n'est pas responsable des dommages indirects ou accessoires. Toute marchandise est vendue à cette condition et aucun représentant de la société ne peut renoncer à l'application de cette politique ou la modifier. Ce produit n'est pas destiné à des fins institutionnelles ou commerciales; Lifetime Products, Inc. n'assume aucune responsabilité à cet égard. Toute utilisation institutionnelle ou commerciale annule la garantie.

La présente garantie remplace expressément toute autre garantie, expresse ou implicite, y compris les garanties de qualité marchande ou d'adaptation à un usage particulier dans la mesure permise par les lois du pays ou de l'État. Ni Lifetime Products, Inc. ni aucun de ses représentants n'assument une quelconque responsabilité en lien avec ce produit. Cette garantie vous donne des droits juridiques précis et vous pourriez également avoir d'autres droits selon l'État ou la province.

AUSTRALIE: La garantie qui accompagne nos produits ne peut être exclue en vertu de la loi sur la protection du consommateur de l'Australie. Le client a droit à un remplacement ou à un remboursement en cas de bris majeur et pour toute autre perte ou dommage raisonnablement prévisible. Le client a aussi droit à ce que les produits soient réparés ou remplacés si un bris survient et rend la qualité inacceptable sans pour autant être qualifiable de bris majeur.

**TOUTE RÉCLAMATION EN VERTU DE LA GARANTIE DOIT ÊTRE ACCOMPAGNÉE D'UN REÇU DE VENTE.  
SIGNALEMENT ÉCRIT DE TOUT PRODUIT DÉFECTUEUX:**

LIFETIME PRODUCTS, INC.,  
PO Box 160010  
Freeport Center, Bldg. D-12  
Clearfield, UT 84016-0010

Pour effectuer en ligne une réclamation sous garantie, consultez cette adresse : [www.lifetime.com/warranty](http://www.lifetime.com/warranty)  
Service de la garantie : (800) 225-3865

### **GARANTIE INTERNATIONALE:**

Toute réclamation en vertu de la garantie doit être accompagnée d'un reçu de vente. Veuillez signaler par écrit tout produit défectueux au représentant du soutien aux ventes de votre région. Veuillez inclure le reçu de vente daté ainsi que des photographies des pièces endommagées.

Pour connaître le représentant de votre région, veuillez consulter le : [www.lifetime.com/international](http://www.lifetime.com/international)





## GARANTÍA DE FÁBRICA LIMITADA POR 10 AÑOS

### **EL FABRICANTE SE RESERVA EL DERECHO DE HACER SUSTITUCIONES EN LOS ELEMENTOS REEMPLAZADOS BAJO GARANTÍA SI LAS PIEZAS NO ESTÁN DISPONIBLES O SON OBSOLETAS.**

El comprador original recibe una garantía de que los productos de césped y jardín de Lifetime están libres de defectos de material o mano de obra durante un período de 10 años a partir de la fecha de compra original al por menor. La palabra “defectos” se define como imperfección que imposibilita el uso del producto. Los defectos ocasionados por el mal uso, el abuso o la negligencia anularán esta garantía. Esta garantía no cubre los defectos debidos a una instalación incorrecta, una alteración o un accidente. Lifetime recomienda que no se realicen modificaciones en este producto. Esta garantía no cubre los daños causados por vandalismo, oxidación, “actos de la naturaleza”, desastres naturales, desgaste normal o cualquier otro evento fuera del control del fabricante.

Esta garantía no es transferible y se limita expresamente a la reparación o reemplazo de productos defectuosos. Si el producto resulta defectuoso dentro de los términos de esta garantía, Lifetime Products, Inc. reparará o reemplazará las piezas defectuosas sin costo alguno para el comprador. Los gastos de envío hacia y desde la fábrica o el centro de distribución no están cubiertos y son la responsabilidad del comprador. La mano de obra y los gastos relacionados por la remoción, la instalación o la sustitución del producto o sus componentes no están cubiertos por esta garantía.

Esta garantía no cubre los rayones, los raspones ni otros daños superficiales del producto que pueden resultar del uso normal. Asimismo, los defectos resultantes de daños intencionales, negligencia o uso indebido anularán o no están cubiertos por esta garantía.

Se excluye la responsabilidad por daños imprevistos o derivados en la medida en que lo permita la ley. Toda la mercancía se vende bajo estas condiciones y ningún representante de la empresa puede renunciar a ni cambiar esta política. Este producto no está destinado para uso institucional o comercial; Lifetime Products, Inc. no asume ninguna responsabilidad por dicho uso. El uso institucional o comercial anulará la garantía.

Esta garantía sustituye expresamente cualquier otra garantía, expresa o implícita, incluidas las garantías de comercialización o idoneidad para su uso en la medida permitida por la ley federal y estatal. Ni Lifetime Products, Inc., ni ningún representante asume ninguna otra responsabilidad en relación con este producto. Esta garantía le otorga derechos legales específicos y usted también puede tener otros derechos que varían de un estado a otro.

Nuestros productos vienen con garantías que no se pueden excluir bajo la Ley Australiana del Consumidor. Usted tiene derecho a recibir un reemplazo o reembolso por un fallo grave y compensación por cualquier otra pérdida o daño razonablemente previsible. También tiene derecho a la reparación o el reemplazo de los bienes si los bienes no son de calidad aceptable y el fallo no supone un fallo grave.

### **TODOS LOS RECLAMOS DE GARANTÍA DEBEN ESTAR ACOMPAÑADOS POR UN RECIBO DE COMPRA. REPORTE LOS DEFECTOS DEL PRODUCTO POR ESCRITO A:**

LIFETIME PRODUCTS, INC.,  
PO Box 160010  
Freeport Center, Bldg. D-12  
Clearfield, UT 84016-0010

Para realizar reclamos de garantía por internet, visite: [www.lifetime.com/warranty](http://www.lifetime.com/warranty).  
Departamento de Garantías: (800) 225-3865

### **PARA LA GARANTÍA INTERNACIONAL:**

Todos los reclamos de garantía deben estar acompañados por un recibo de compra. Reporte los defectos del producto por escrito a su representante regional de apoyo de ventas. Por favor, incluya su recibo de compra con la fecha y fotografías de las piezas dañadas.

Para identificar al representante de su región, por favor visite: [www.lifetime.com/international](http://www.lifetime.com/international)

### **GARANTIA NO VÁLIDA EN MÉXICO**

**ENHANCE YOUR LIFETIME® PURCHASE BY ADDING ACCESSORIES OR OTHER GREAT PRODUCTS**

*To purchase accessories or other Lifetime® products, visit us at:*

***www.lifetime.com***

*Or call: 1-800-424-3865*

**AMÉLIORER L'ACHAT LIFETIME® EN AJOUTANT DES ACCESSOIRES OU D'AUTRES PRODUITS**

*Pour acheter des accessoires ou des autres produits Lifetime®, visiter le :*

***www.lifetime.com***

*Ou composer le 1-800-424-3865*

**MEJORAR LA COMPRA DE LIFETIME® AGREGANDO ACCESORIOS U OTROS MARAVILLOSOS PRODUCTOS**

*Para comprar accesorios u otros productos de Lifetime®, visitarnos en:*

***www.lifetime.com***

*O marcar al 1-800-424-3865*



[www.lifetime.com](http://www.lifetime.com)

