

## Mid-Rise Scissor Lift

# Installation and Operation Manual

Manual P/N 5900030 — Manual Revision D4 — August 2023

**Models:** • MDS-6EXT • MDS-6EXTF • MDS-6LP • MDS-6LPF

*Original Instructions in  
the English Language*

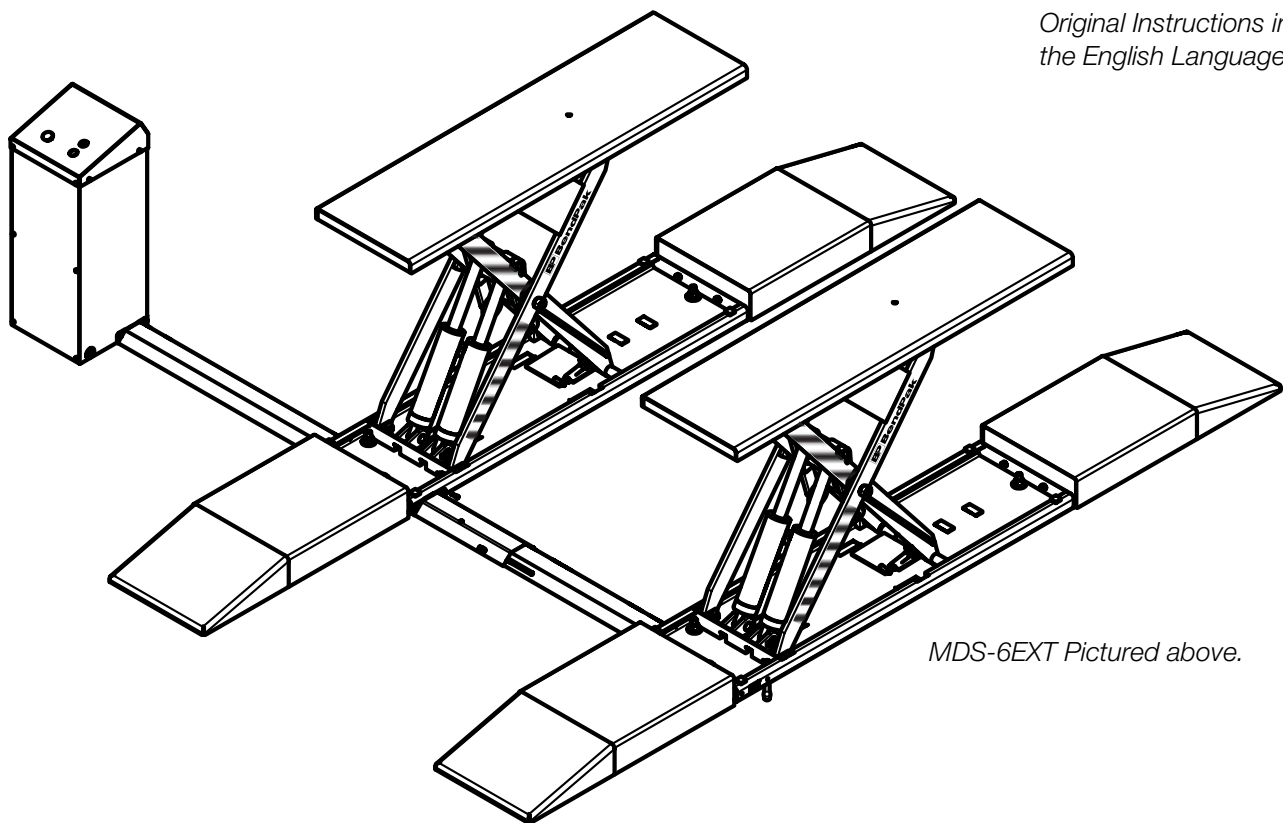

*MDS-6EXT Pictured above.*

**Designed and engineered by BendPak Inc. in Southern California, USA. Made in China.**

 **DANGER**

**IMPORTANT SAFETY INSTRUCTIONS, SAVE THESE INSTRUCTIONS! Read the entire contents** of this manual **before** using this product. Failure to follow the instructions and safety precautions in this manual can result in severe injury or death. Make sure all other operators also read this manual. Keep the manual near the product for future reference. **By proceeding with setup and operation, you agree that you fully understand the contents of this manual and assume full responsibility for product use.**

**Manual.** MDS-6 Series Mid-Rise Scissor Lifts, *Installation and Operation Manual*, Manual Part Number 5900030, Manual Revision D4, released August 2023.

**Copyright.** Copyright © 2022 by BendPak Inc. All rights reserved. You may make copies of this document if you agree that: you will give full attribution to BendPak Inc., you will not make changes to the content, you do not gain any rights to this content, and you will not use the copies for commercial purposes.

**Trademarks.** BendPak and the BendPak logo are registered trademarks of BendPak Inc. All other company, product, and service names are used for identification only. All trademarks and registered trademarks mentioned in this manual are the property of their respective owners.

**Limitations.** Every effort has been made to ensure complete and accurate instructions are included in this manual. However, product updates, revisions, and/or changes may have occurred since this manual was published. BendPak reserves the right to change any information in this manual without incurring any obligation for equipment previously or subsequently sold. All drawings are reference only – do not scale. BendPak is not responsible for typographical errors in this manual. You can always find the latest version of the **manual for your product on the BendPak website**.



SCAN FOR  
DIGITAL PDF

**Warranty.** The BendPak warranty is more than a commitment to you: it is also a commitment to the value of your new product. Contact your nearest BendPak dealer or visit [www.bendpak.com/support/warranty](http://www.bendpak.com/support/warranty) for full warranty details. Go to [bendpak.com/support/register-your-product/](http://bendpak.com/support/register-your-product/) and fill out the online form to register your product (be sure to click **Submit**).

**Safety.** Your new product was designed and manufactured with safety in mind. Your safety also depends on proper training and thoughtful operation. Do not set up, operate, maintain, or repair the unit without reading and understanding this manual and the labels on the unit; **do not use your Lift unless you can do so safely!**

**Owner Responsibility.** In order to ensure operator safety and maintain your product properly, it is the responsibility of the product owner to read and follow these instructions:

- Follow all setup, operation, and maintenance instructions.
- Make sure product setup conforms to all applicable local, state, and federal codes, rules, and regulations, such as state and federal OSHA regulations and electrical codes.
- Read and follow all safety instructions. Keep them readily available for operators.
- Make sure all operators are properly trained, know how to safely operate the unit, and are properly supervised.
- Do not operate the product until you are certain that all parts are in place and operating correctly.
- Carefully inspect the product on a regular basis and perform all maintenance as required.
- Service and maintain the unit only with approved replacement parts.
- Keep all instructions permanently with the product and verify all labels are clean and visible.
- **BendPak** makes no promises, guarantees or assurances that our products meet any state, county, federal or international mandated permit, license, code, standard, certification, or any other mandate other than what is listed or shown on BendPak website(s), or any BendPak online or published catalog. Not all BendPak lift models meet the standards as prescribed by ANSI/ALI ALCTV-(current edition) or ANSI/UL 201. Consult [www.autolift.org](http://www.autolift.org) for a complete list of lift models that meet ANSI/ALI ALCTV-(current edition) or ANSI/UL 201, or contact BendPak via [www.bendpak.com/contact/](http://www.bendpak.com/contact/) **Buyer assumes full responsibility for any state, county, federal or international mandated permit, license, code, standard, certification, or any other mandate required related to the installation and/or operation of any BendPak or Autostacker product.** BendPak will not be responsible for any charges, fines, liens, or other levies imposed on the Buyer related to any special or regional structural, seismic or any other building code and/or codes such as the Uniform Building Code (UBC), International Building Code (IBC), or any other state, county, federal or international mandated permit, license, code, standard, certification, or other mandate, law, rule, regulation or directive by any other agency, government, administrations, or corporations whether state, county, federal, or international mandated.
- **Only use the Lift if it can be used safely!**

**Unit Information.** Enter the Model Number, Serial Number, and the Date of Manufacture from the label on your unit. This information is required for part or warranty issues.

Model: \_\_\_\_\_

Serial: \_\_\_\_\_

Date of Manufacture: \_\_\_\_\_

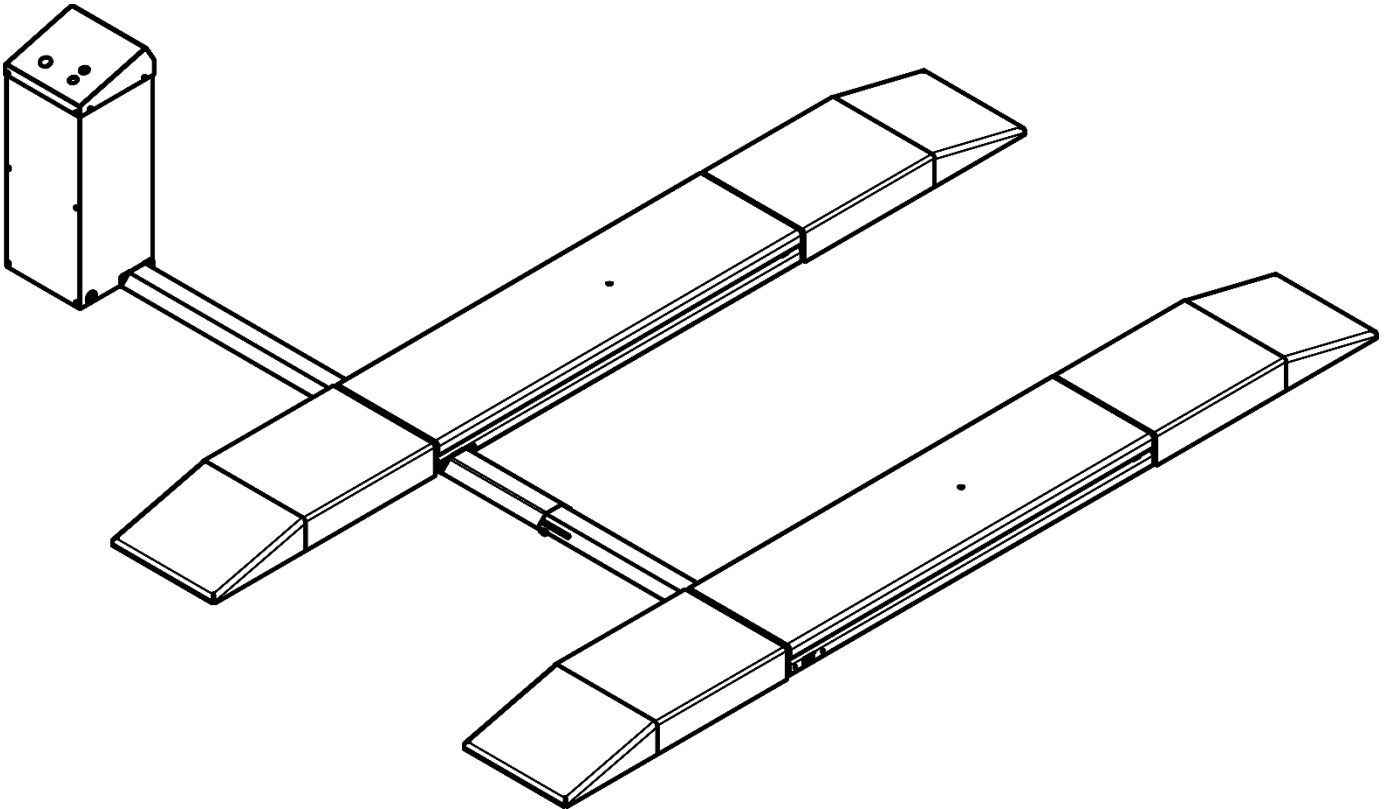

*Figure not to scale.*

# Table of Contents

<b>Introduction</b> .....	<b>4</b>	<b>Operation</b> .....	<b>67</b>
<b>Shipping Information</b> .....	<b>5</b>	<b>Maintenance</b> .....	<b>75</b>
<b>Safety Considerations</b> .....	<b>5</b>	<b>Troubleshooting</b> .....	<b>76</b>
<b>FAQ</b> .....	<b>8</b>	<b>Wiring Diagram</b> .....	<b>77</b>
<b>Components</b> .....	<b>9</b>	<b>Labels</b> .....	<b>80</b>
<b>Specifications</b> .....	<b>10</b>	<b>Parts Diagrams</b> .....	<b>83</b>
<b>Installation Checklist</b> .....	<b>15</b>	<b>ALI Store</b> .....	<b>97</b>
<b>Installation</b> .....	<b>16</b>	<b>Maintenance Log</b> .....	<b>98</b>

## Introduction

This manual describes the following Mid-Rise Scissor Lift models:

- **MDS-6EXT**: Mid-Rise Scissor Lift with extended length Platforms that can raise up to 6,000 lbs. (2,722 kg).
- **MDS-6EXTF**: The flush-mount version of the MDS-6EXT.
- **MDS-6LP**: Mid-Rise Scissor Lift with normal length Platforms but a higher rise that can raise up to 6,000 lbs. (2,722 kg). ALI certified.
- **MDS-6LPF**: The flush-mount version of the MDS-6LP. ALI certified.

More information about the full line of BendPak products is available at [bendpak.com](http://bendpak.com).

**⚠ DANGER** Be very careful when setting up, operating, maintaining, or repairing this equipment; failure to do so could result in property damage, product damage, injury, or (in very rare cases) death. Make sure only authorized personnel operate this equipment. An authorized technician must perform all repairs. Do not make modifications to the unit; this voids the warranty and increases the chances of injury or property damage. Make sure to read and follow the instructions on the labels on the unit.

***This manual is mandatory reading for all users of MDS-6 Series Lifts***, including anyone who installs, operates, maintains, or repairs them. Always keep this manual on or near the equipment.

Technical support and service is available from your dealer, on the Web at [bendpak.com/support](http://bendpak.com/support), by email at [support@bendpak.com](mailto:support@bendpak.com), or by phone at **(800) 253-2363**, option 7, then 4.

Online chat is also available at [www.bendpak.com](http://www.bendpak.com) click the chat icon. 

Scan this QR Code for up-to-date information and videos on the 12AP-SRT Lift series.



---

# Shipping Information

Your equipment was carefully checked before shipping. Nevertheless, you should thoroughly inspect the shipment **before** you sign to acknowledge that you received it.

When you sign the bill of lading, it tells the carrier that the items on the invoice were received in good condition. **Do not sign the bill of lading until after you have inspected the shipment.** If any of the items listed on the bill of lading are missing or damaged, do not accept the shipment until the carrier makes a notation on the bill of lading that lists the missing and/or damaged goods.

If you discover missing or damaged goods **after** you receive the shipment and have signed the bill of lading, notify the carrier at once and request the carrier to make an inspection. If the carrier will not make an inspection, prepare a signed statement to the effect that you have notified the carrier (on a specific date) and that the carrier has failed to comply with your request.

It is difficult to collect for loss or damage after you have given the carrier a signed bill of lading. If this happens to you, file a claim with the carrier promptly. Support your claim with copies of the bill of lading, freight bill, invoice, and photographs. Our willingness to assist in helping you process your claim does not make us responsible for collection of claims or replacement of lost or damaged materials.

## Safety Considerations

**Read this entire manual carefully before using your new product.** Do not install or operate the product until you are familiar with all operating instructions and warnings. Refer to ANSI/ALI ALIS Standard *Safety Requirements for Installation and Service of Automotive Lifts* for more information about safely installing your Lift.

 **WARNING** **California Proposition 65.** This product can expose you to chemicals including styrene and vinyl chloride which are on the list of over 900 chemicals identified by the State of California to cause cancer, birth defects or reproductive harm. **ALWAYS** use this product in accordance with BendPak's instructions. For more information go to [www.P65Warnings.ca.gov](http://www.P65Warnings.ca.gov).

### IMPORTANT SAFETY INSTRUCTIONS!

#### SAVE THESE INSTRUCTIONS!





1. Read all instructions.
2. Care must be taken as burns can occur from touching hot parts.
3. Do not operate equipment with a damaged cord or if the equipment has been dropped or damaged – until a qualified service person has examined it.
4. Do not let a cord hang over the edge of a table, bench, or counter or come in contact with hot manifolds or moving fan blades.
5. If an extension cord is necessary, a cord with a current rating equal to or more than that of the equipment should be used. Cords with a current rating less than the equipment may overheat. Care should be taken to arrange the cord so that it will not be tripped over or pulled.
6. Always unplug the equipment from the electrical outlet when not in use. Never use the cord to pull the plug from the outlet. Grasp the plug and pull to disconnect.

- 
7. Let the equipment cool completely before putting away. Loop cord loosely around equipment when storing.
  8. To reduce the risk of fire, do not operate in the vicinity of open containers of flammable liquids (gasoline).
  9. Adequate ventilation should be provided when working on operating internal combustion engines.
  10. Keep hair, loose clothing, fingers, and all parts of body away from moving parts.
  11. To reduce the risk of electric shock, do not use on wet surfaces or expose to rain.
  12. Use only as described in this manual. Use only BendPak recommended attachments.
  13. ALWAYS WEAR SAFETY GLASSES. Everyday eyeglasses only have impact resistant lenses, they are not safety glasses.
  14. To reduce the risk of injury, close supervision is necessary when this product will be used around children.
  15. To reduce the risk of injury, **never** attempt to lift more than the rated capacity. Refer to loading instructions.
  16. The Lift uses electrical energy; if your organization has Lockout/Tagout policies, make sure to implement them after connecting the Lift to a power source.
  17. Refer to markings for proper load on electrical receptacles.
  18. Only operate your Lift between temperatures of +41°F to +104°F (+5°C to +40°C).
  19. The Lift should **only** be operated by authorized personnel. Keep children and untrained personnel away from the Lift.
  20. Do not make any modifications to the Lift; this voids the warranty and increases the chances of injury or property damage.
  21. Do not use the Lift while tired or under the influence of drugs, alcohol, or medication.
  22. Consider the work environment. Keep the work area clean. Cluttered work areas invite injuries. Keep areas well lit.
  23. **Always** make sure the Lift is secured on Safety Locks before attempting to work on or near a Vehicle.
  24. Make a thorough inspection of the product at least once a year. Replace any damaged or severely worn parts, decals, or warning labels. Replace worn or damaged parts with BendPak or BendPak approved parts and assemblies only.
  25. BendPak recommends referring to the ANSI/ALI ALIS Standard *Safety Requirements for Installation and Service* for more information about safely installing, using, and servicing your Lift.
  26. MDS-6 Series Lifts are Mid-Rise Service Lifts. **Use them only for their intended purpose.**
  27. You **must** wear OSHA-approved (publication 3151) personal protective equipment at all times when installing, using, maintaining, or repairing the Lift. Leather gloves, steel-toed work boots, eye protection, back belts, and hearing protection are **mandatory**.
  28. Keep loads balanced on the Lift Arms. Clear the area immediately if a Vehicle is in danger of falling off the Lift. Do not make any modifications to the Lift.
  29. Modifications void the warranty and increases the chances of injury or property damage. Do not modify any safety-related features in any way.

- 
30. Make sure all operators read and understand this Installation and Operation Manual. Keep the manual near the Lift at all times.
31. While handling a Hydraulic Cylinder or a Hydraulic Hose, **always** wear gloves. In rare cases, a needle-like stream of hydraulic fluid (even at low pressure) can penetrate fingers, hands, or arms; such a puncture can feel like a bite, electric shock, or a prick. While it may seem like a minor issue, any amount of Hydraulic Fluid injected into the human body is a serious issue. Anyone suffering such a puncture wound should be **immediately** taken to a hospital emergency room to determine the extent of the injury. Explain the circumstances of the injury to the attending physician, including what kind of Hydraulic Fluid was involved. Do not assume a puncture wound that could have been caused by Hydraulic Fluid is a minor issue; it could be life threatening.
32. Inspect the Lift **before** using it. Check for damaged, worn, or missing parts. Do not use it if you find any of these issues. Instead, take it out of service, then contact an authorized repair facility, your dealer, or BendPak at **(877) 432-6627** or [support@BendPak.com](mailto:support@BendPak.com).

## Symbols

Following are the symbols used in this manual:

-  **DANGER** Calls attention to an immediate hazard that **will** result in injury or death.
-  **WARNING** Calls attention to a hazard or unsafe practice that **could** result in injury or death.
-  **CAUTION** Calls attention to a hazard or unsafe practice that could result in minor personal injury, product, or property damage.
- NOTICE** Calls attention to a situation that, if not avoided, could result in product or property damage.
-  **Tip** Calls attention to information that can help you use your product better.

## Liability Information

BendPak Inc. assumes **no** liability for damages resulting from:

- Use of the product for purposes other than those described in this manual.
- Modifications to the equipment without prior written permission from BendPak Inc.
- Injury or death caused by modifying, disabling, overriding, or removing safety features.
- Damage to the equipment from external influences.
- Incorrect operation of the equipment.

---

# Frequently Asked Questions

**Question:** How much weight can MDS-6 Series Lifts raise?

**Answer:** They can raise Vehicles up to 6,000 pounds (2,722 kg).

**Q:** What is the difference between the MDS-6EXT and MDS-6LP Lifts?

**A:** The MDS-6EXT/F include **extended-length Platforms**, so it can raise Vehicles with longer wheelbases. The MDS-6LP/F can **raise Vehicles higher**.

**Q:** How high does a “mid-rise” Scissor Lift raise a Vehicle?

**A:** There are differences between the four models, but they all raise about three feet, plus a little extra height from the Lift Blocks.

**Q:** What does “flush mount” mean?

**A:** It means the Frames of the MDS-6EXTF and MDS-LPF are installed below the surface of the Concrete, in a Concrete Cutout, so Vehicles drive straight onto the Platforms without having to go up a Ramp (the tops of the Platforms are “flush” with the floor).

**Q:** Can the Lifts covered in this manual be installed outdoors?

**A:** No. All Lifts described herein are approved for indoor installation and use only. Outdoor installation is prohibited.

**Q:** Can I put the Console on either side of the Lift?

**A:** Yes. The Hydraulic Hoses and the Covers that come with the Lifts are long enough to support the Console up to 40 inches away on either side. The Console must be positioned on the Cylinder side of the Lift near the side openings in the Bases; the Air Line, Return Line, and Hydraulic Hoses are routed through them.

**Q:** What does a Safety Lock do?

**A:** Safety Locks hold the Platforms up, **once they are engaged**. Even if the Lift loses power, the Platforms stay where they are if they are left engaged on a Safety Lock. **Only leave your Lift either fully lowered or engaged on a Safety Lock.**

**Q:** How many Safety Locks do the MDS-6 Series Lifts have?

**A:** Three.

# Components

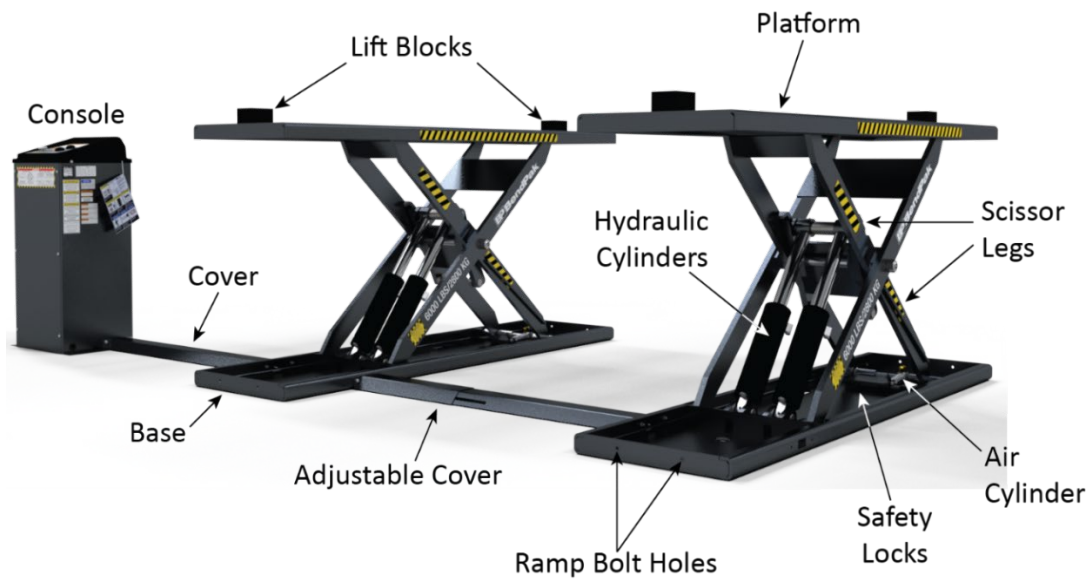

*MDS-6EXT shown without Ramps. Power Unit and Flow Divider are inside the Console. Air and Hydraulic Hoses are routed under the two Covers.*

Lift components include:

- **Console** — Hosts the Lift Controls (on top) and the Power Unit and Flow Divider (inside). The Air and Hydraulic Hoses connect to the Power Unit inside the Console.
- **Power Unit** — Provides Hydraulic Fluid and pressure to the Hydraulic Cylinders. Housed inside the Console. Connects to an external power source and to the Lift Controls.
- **Flow Divider** — Evenly divides the Hydraulic Fluid coming from the Power Unit so that the Platforms raise and lower together.
- **Drive-up Ramps** — Used to drive onto and off the Platforms for the MDS-6EXT and MDS-6LP. Not included with the MDS-6EXTF or the MDS-6LPF.
- **Platforms** — The tops of the Lift. Flat steel plates that raise and lower.
- **Lift Blocks** — Rubber blocks that contact the lifting points on the underside of the Vehicle being raised. Eight tall and eight medium Lift Blocks are included.
- **Base** — The bottom of the Lift. They hold the Hydraulic Cylinders, the Scissor Legs, the Safety Locks, and the Air Cylinder. You anchor the Lift in place using the Anchor Bolt holes in each Base.
- **Frames** — The Platform, Base, and Scissor Legs taken together are called a Frame. All four models described in this manual have two Frames.
- **Scissor Legs** — The parts of the Lift that raise and lower, powered by the Hydraulic Cylinders.
- **Hydraulic Cylinders** — Push the Platforms up to raise a Vehicle, move them down to lower it.
- **Safety Locks** — Hold the Platforms in place. Each Lift has multiple Safety Lock positions, which let you select the best Platform height for your needs.
- **Air Cylinders** — Push the Platforms off their Safety Locks so you can lower the Lift. You must provide an air pressure supply (minimum 50 psi / 10 CFM, regulated to a maximum of 125 psi).
- **Cover and Adjustable Cover** — Cover the Air and Hydraulic Hoses.
- **Side Holes** — Holes in the sides of the Base through which the Air Line, Return Line, and Hydraulic Hoses are routed.

# Specifications

## MDS-6EXT and MDS-6EXTF

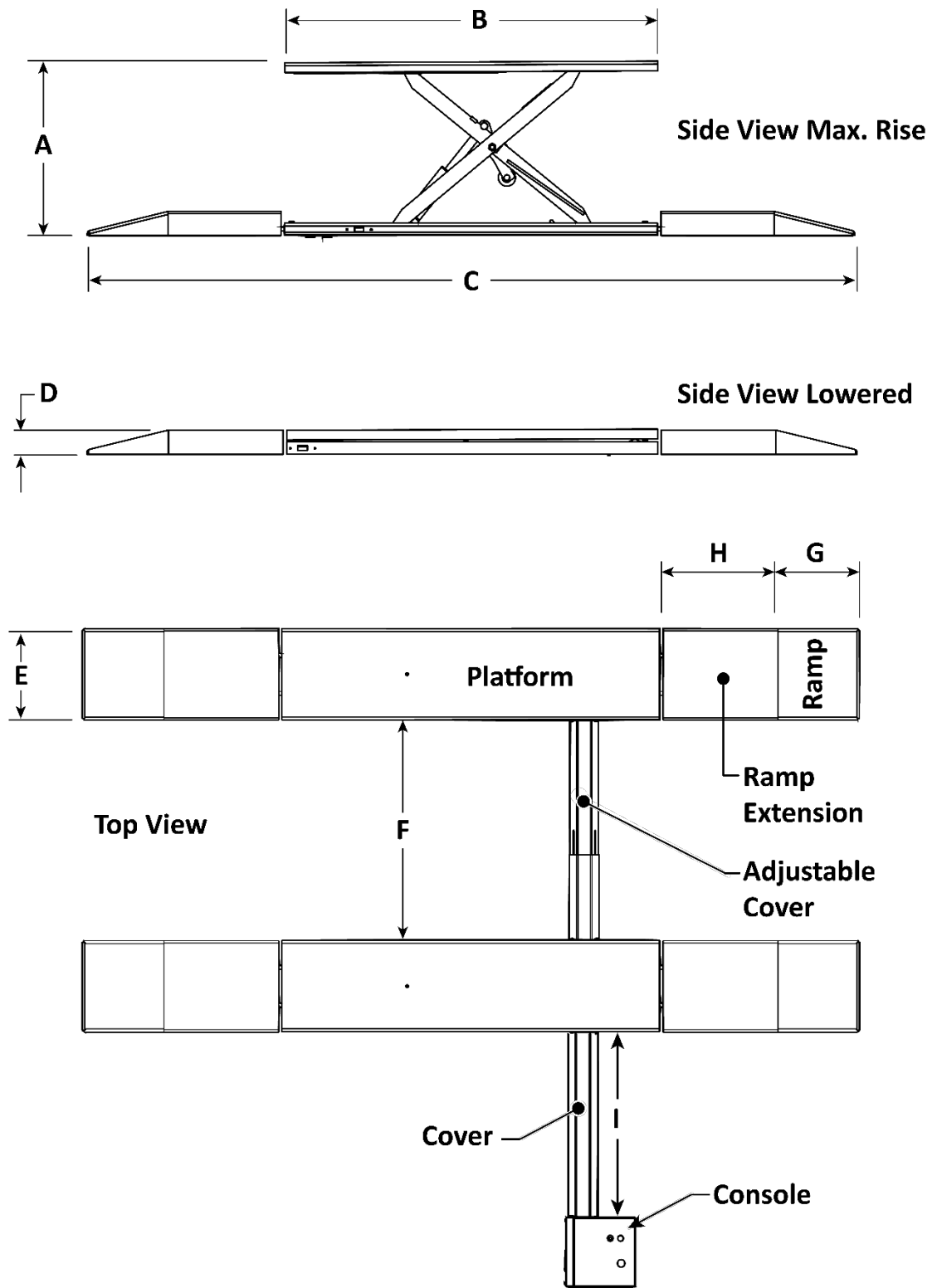

*The MDS-6EXTF and MDS-6LPF do not include Ramps or Covers. Do not scale drawing.*

<b>Model</b>	<b>MDS-6EXT</b>	<b>MDS-6EXTF</b>
Type	Surface Mount	Flush Mount
Lifting capacity	6,000 lbs. / 2,722 kg	6,000 lbs. / 2,722 kg
<b>A</b> Lifting height (full rise - no blocks)	36.75 in. / 933 mm	36.75 in. / 933 mm
Lifting height (full rise) Med. lift blocks 1.5 in. (38mm)	38.25 in. / 972 mm	38.25 in. / 972 mm
Lifting height (full rise) Tall lift blocks 2.9 in. (75mm)	39.65 in. / 1,007 mm	39.65 in. / 1,007 mm
<b>B</b> Platform length	78.75 in. / 2,000 mm	78.75 in. / 2,000 mm
<b>C</b> Total length	<i>Ramps Only:</i> 114.25 in. / 2,902 mm <i>Ramps and Extensions:</i> 162 in. / 4116 mm	78.75 in. / 2,000 mm (No ramps or extensions)
<b>D</b> Lowered height	5.25 in. / 133 mm	5.25 in. / 133 mm (Top of Platform to be Flush with floor)
<b>E</b> Platform width	19 in. / 484 mm	19 in. / 484 mm
<b>F</b> Width between Platforms	40 to 46 in. / 1,018 to 1,168 mm	40 to 46 in. / 1,018 to 1,168 mm
<b>G</b> Ramp Length	17 in. / 432 mm	N/A No Ramps
<b>H</b> Ramp Extension Length	24 in. / 607 mm	N/A No Extensions
<b>I</b> Max. Platform to Console	40 in. / 1,024 mm	40 in. / 1,024 mm
Lifting time	35 seconds	35 seconds
Hydraulic Pressure Developed at Max. Capacity	1700 psi / 11.72 N/m <sup>2</sup>	
Motor	110 VAC at 50-60 Hz., 1 Ph. 220 VAC at 50 Hz., 1 Ph. 208-230 VAC at 60 Hz., 1 Ph.	

**Specifications subject to change without notice.**

# MDS-6LP and MDS-6LPF



*The MDS-6LPF does not include Ramps or Covers. Do not scale drawing.*

<b>Model</b>	<b>MDS-6LP</b>	<b>MDS-6LPF</b>
Type	Surface Mount	Flush Mount
Lifting capacity	6,000 lbs. / 2,722 kg	6,000 lbs. / 2,722 kg
<b>A</b> Lifting height (full rise - no blocks)	44.5 in. / 1,130 mm	44.5 in. / 1,130 mm
Lifting height Med. Lift blocks 1.5 in. (38 mm)	46 in. / 1,168 mm	46 in. / 1,168 mm
Lifting height Tall Lift blocks 2.9 in. (75 mm)	47.5 in. / 1,206.5 mm	47.5 in. / 1,206.5 mm
<b>B</b> Platform length	67 in. / 1,701 mm	67 in. / 1,701 mm
<b>C</b> Total length	<i>Ramps Only:</i> 102.5 in. min. / 2,603 mm <i>Ramps and Extensions:</i> 150.25 in. max. / 3,817 mm	67 in. / 1,701 mm (No ramps or extensions)
<b>D</b> Lowered height	5.2 in. / 132 mm	5.2 in. / 132 mm (Top of Platform to be Flush with floor)
<b>E</b> Platform width	19 in. / 484 mm	19 in. / 484 mm
<b>F</b> Width between Platforms	40 to 46 in. / 1,018 to 1,168 mm	40 to 46 in. / 1,018 to 1,168 mm
<b>G</b> Ramp Length	17 in. / 432 mm	N/A No Ramps
<b>H</b> Ramp Extension Length	24 in. / 607 mm	N/A No Ramps or Extensions
<b>I</b> Maximum Distance to Console	40.25 in. / 1,022 mm	40.25 in. / 1,022 mm
Lifting time	35 seconds	35 seconds
Hydraulic Pressure Developed at Max. Capacity	1700 psi / 11.72 N/m <sup>2</sup>	
Power Unit Motor	110 VAC at 50-60 Hz., 1 Ph. 220 VAC at 50 Hz., 1 Ph. 208-230 VAC at 60 Hz., 1 Ph.	

**Specifications subject to change without notice.**

# MDS-6 Series Console

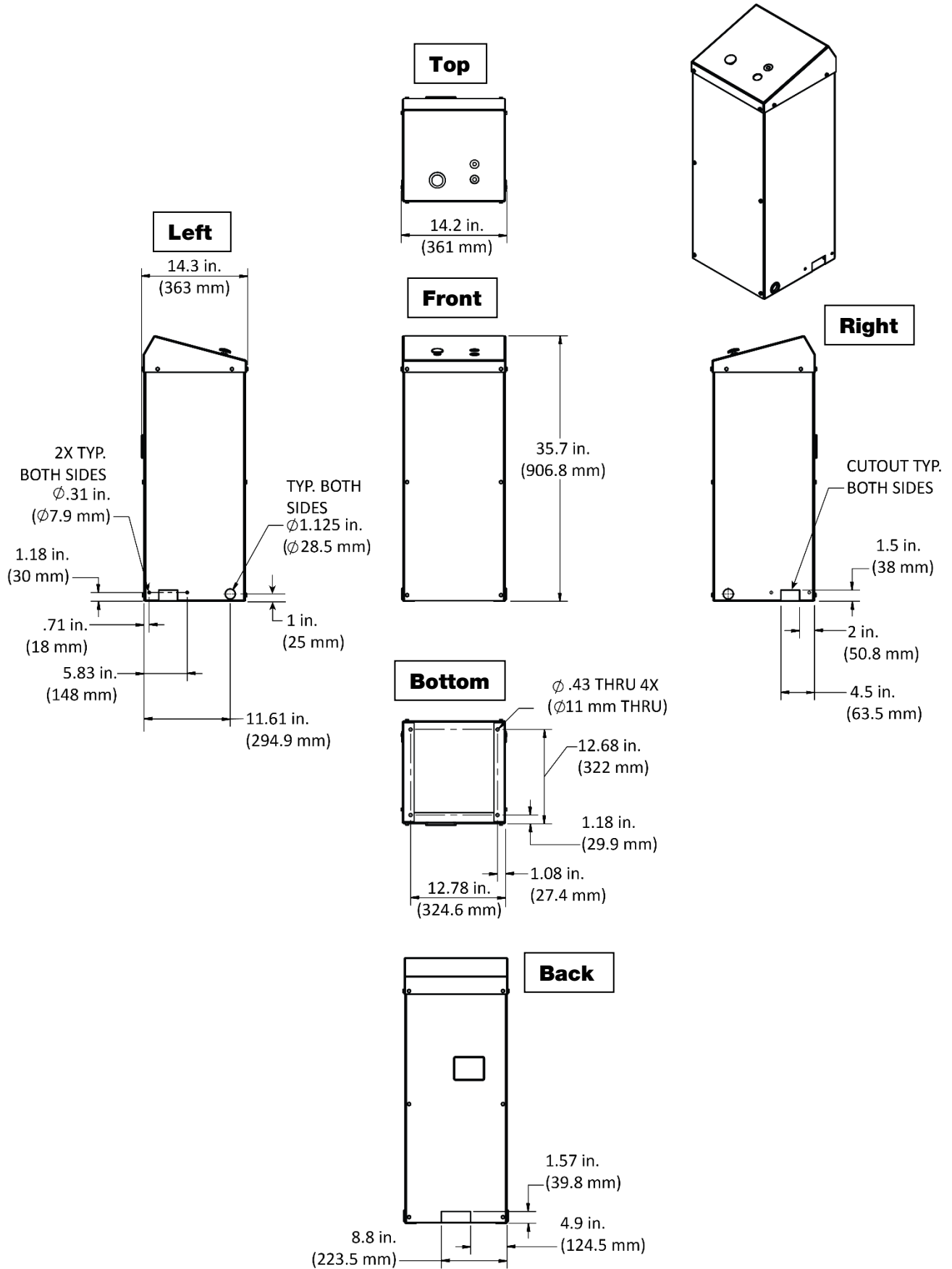

---

# Installation Checklist

The following are the steps needed to install the Lift. Perform them in the order shown.

- 1. Review the installation Safety Rules.
- 2. Plan for Electrical Work.
- 3. Make sure you have the necessary Tools.
- 4. Select the installation Site, verify Concrete depth and compressive strength.
- 5. Check Clearances around and above the proposed Lift site.
- 6. Create New Pour/Concrete Cutouts, if required.
- 7. Create a Floor Plan.
- 8. Lift the Platforms off the Bases.
- 9. Read and understand, About Effective Embedment.
- 10. Anchor the Bases.
- 11. Level the Lift Platforms
- 12. Grouting the Lift Bases (if required).
- 13. Assemble and Anchor the Console.
- 14. Install the Power Unit.
- 15. Read, Avoiding Hydraulic Contamination and Hydraulic System Warnings.
- 16. Read about Thread Sealant.
- 17. Connect the Hydraulic Hoses.
- 18. Understand Compression Fittings and Tubing.
- 19. Connect the Air Lines.
- 20. Connect the Return Lines.
- 21. Install the inner and outer hose covers.
- 22. Contact the Electrician.
- 23. Connect and prepare the Power Unit (**Electrician required**).
- 24. Fill the Hydraulic Fluid Reservoir and verify all Hydraulic Fittings and Plugs are tightened.
- 24. Install a Power Disconnect Switch (**Electrician required**).
- 25. Install a Thermal Disconnect Switch (**Electrician required**).
- 26. Lubricate the Lift.
- 27. Add the Ramps.
- 28. Anchor the Console (if it is not already anchored).
- 29. Perform an Operational Test.
- 30. Review the Final Checklist.
- 31. Leave the Manual for the Owner/Operator.

---

# Installation

This section describes how to install your Lift. Perform the steps in the order listed. Correct operation of the Lift requires correct installation. **Take your time, read the instructions, do it right.**

**⚠ WARNING** **Only use the factory-supplied parts that came with your Lift.** If you use parts from a different source, you void your warranty and compromise the safety of everyone who installs or uses the Lift. If you are missing parts, visit [bendpak.com/support](https://bendpak.com/support) or call **(800) 253-2363**, extension 191.

Lift owners are responsible for any special regional, structural, or seismic anchoring requirements specified by any agencies or codes, such as the Uniform Building Code or International Building Code.

## Safety Rules

When installing your Lift, your safety depends on proper training and thoughtful operation.

**⚠ WARNING** Do not install this equipment unless you have automotive Lift installation training. Always use proper lifting tools, such as a Forklift or Shop Crane, to raise heavy components. Do not install this equipment without reading and understanding this manual and the safety labels on the unit.

BendPak recommends referring to the current version of the ANSI/ALI ALIS Standard *Safety Requirements for Installation and Service* for more information about safely installing, using, and servicing your Lift.

Only fully trained personnel should be involved in installing this equipment. **Always pay attention.** Use appropriate tools and lifting equipment, when needed. Stay clear of moving parts.

**⚠ WARNING** You **must** always wear OSHA-approved (publication 3151) Personal Protective Equipment when installing the Lift: leather gloves, steel-toed boots, eye protection, back belts, and hearing protection are **mandatory**.

## Electrical Work

You will need to have a licensed Electrician available at some point during the installation. The things the Electrician needs accomplish are grouped together near the end of the installation.

**⚠ DANGER** a licensed Electrician must perform all wiring.

The Electrician needs to:

- **Connect the 220 VAC power source to the Power Unit.** The Electrician will need to provide a power cable with an appropriate plug. *The power cable and plug are not included.*
- **Install a Power Disconnect Switch.** A Power Disconnect Switch ensures that the equipment shuts down in the event of an electrical circuit fault or emergency. Refer to [Install a Power Disconnect Switch](#) for more information.
- **Install a Thermal Disconnect Switch.** A Thermal Disconnect Switch ensures that the equipment shuts down in the event of an overload or an overheated motor. Refer to [Install a Thermal Disconnect Switch](#) for more information.

It is the responsibility of the Electrician to bring the necessary components.

---

## Tools

You may need some or all of the following tools:

- Rotary Hammer Drill or similar
- 3/4 in. and 3/8 in. Masonry Drill Bits
- Hammer
- Open-end Wrench set: Metric and SAE 1/2 in. to 15/16 in., 1 1/8 in.
- Socket and ratchet set, Metric/SAE to 1-1/8 in.
- Medium Adjustable Wrench
- Spirit Level (4 foot recommended)
- Crowbar
- Chalk line
- Medium Flat Screwdriver
- Tape Measure (25-foot recommended)
- Forklift or Shop Crane
- White Lithium Grease
- Hydraulic Fluid

## Select a Site

Keep the following in mind when selecting a site for your Lift:

 **WARNING** Risk of explosion. This equipment has internal arcing or sparking parts which should not be exposed to flammable vapors.

- **Enough space.** Make sure there is adequate space on all sides, plus enough room above for the Vehicles you will be raising. Refer to **Clearance around the Lift** for more information.
- **No overhead obstructions.** Make sure the site is free of low-hanging overhead obstructions.
- **Plan ahead.** There are Electrical, Air and Hydraulic lines to be routed to the Lift Console and to the Lift itself as well as Concrete specifications and cutouts depending on the model of MDS-6 Lift. Consult with a licensed Electrician, and a Concrete Specialist early in the process to avoid costly mistakes when installing the MDS-6 Series Scissor Lift.

- **Concrete specifications.** Do not install the Lift on cracked or defective concrete. Verify the concrete is reinforced and at least 4.25 inches thick, 3,000 psi compressive strength, and cured for at least 28 days (if newly poured). Make sure the floor is defect-free, dry, and level. Only install the Lift on concrete. Note that flush-mount Lifts require a greater depth of concrete.

If you intend to run the Hydraulic lines to some location further than 40 in. from the Lift, consult with the Concrete Specialist to determine the size, depth, and location of the conduits for the Air and Hydraulic Lines.

 **WARNING** Do not install your Lift on a surface with 3° of slope or greater. A slope in excess of 3° could lead to property damage, personal injury, or death.

- **Power.** You need an appropriate power source near the Console. The electrical circuit must be protected by an appropriate circuit breaker or fuse. If you intend to run the electrical power out to the Console under new pour Concrete, consult with a licensed Electrician to ensure the correct location, depth, size, and type of electrical conduit are installed according to national, state, and local electrical codes.
- **Operating temperature.** The Lift is designed to be used between temperatures of 41° to 104°F (5° to 40°C).
- **Outdoor installation.** All Lift models are approved for **indoor** installation and use only. Outdoor installation is prohibited.
- **Second floor installation.** Do not install the Lift on a second floor or elevated floor without first consulting the building architect and getting their permission.

- **Dress properly.** Wear protective gear (safety goggles, helmet, heavy gloves, suitable working clothes, safety boots, ear protection, and so on) at all times when installing the Lift. Do not wear loose clothing or jewelry; contain long hair; keep hair, clothing, and gloves away from moving parts.
- **Plan Ahead.** There are Electrical, Concrete and Air Lines to be routed to the Lift Console and to the Lift itself. Consult with a licensed Electrician, and a Concrete Specialist early in the process to avoid costly mistakes when installing an MDS-6 Series Scissor Lift.

**⚠ WARNING** Always wear appropriate protective gear when working on the Lift.

## Clearance around the Lift

For safety purposes, a certain amount of clear space around the Lift is **required**.

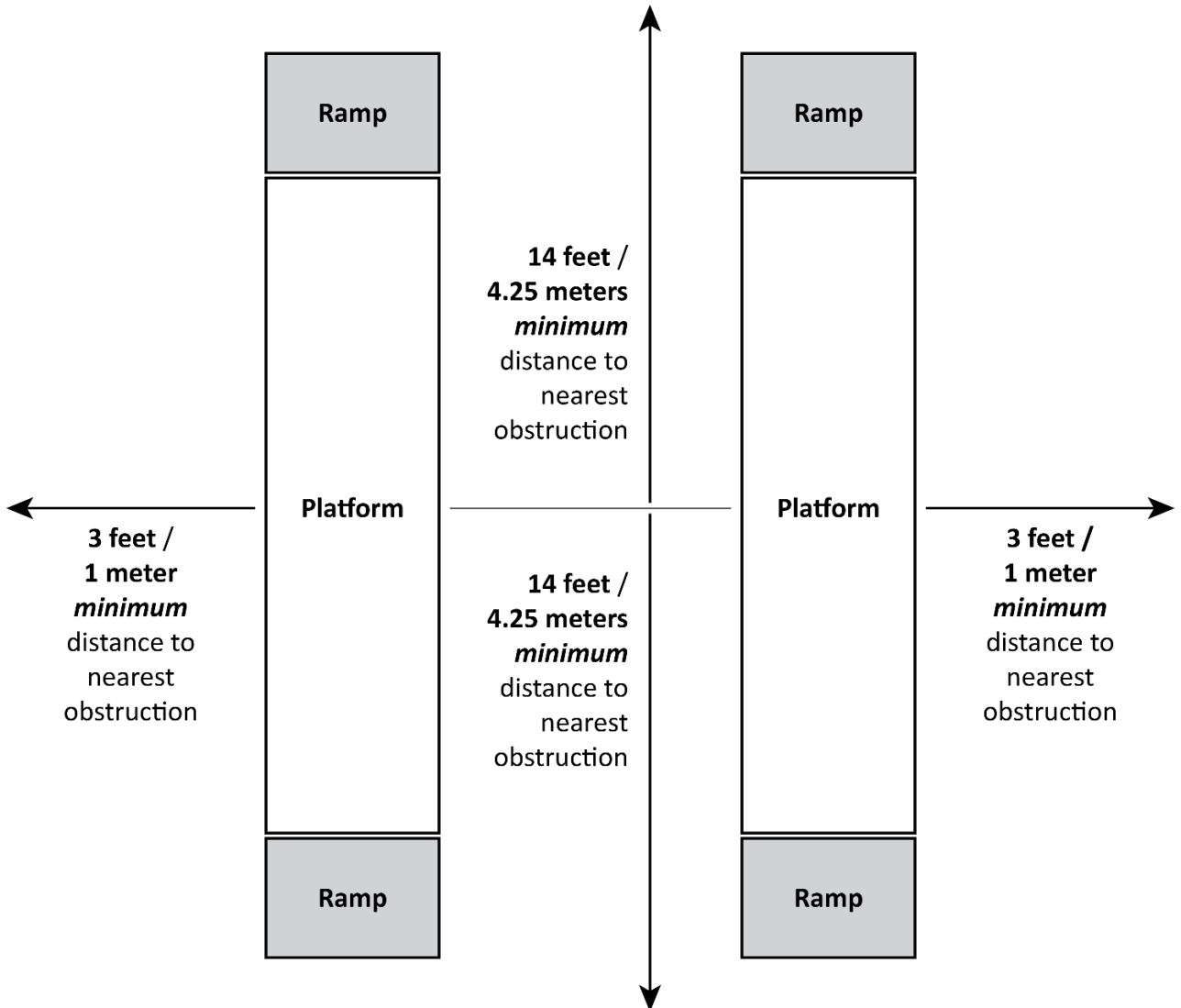

## Clearance above the Lift

Maintain a minimum of 1-inch (25 mm) between any obstruction and the highest point of the vehicle when at **maximum rise** and on the Tall Lift Blocks.

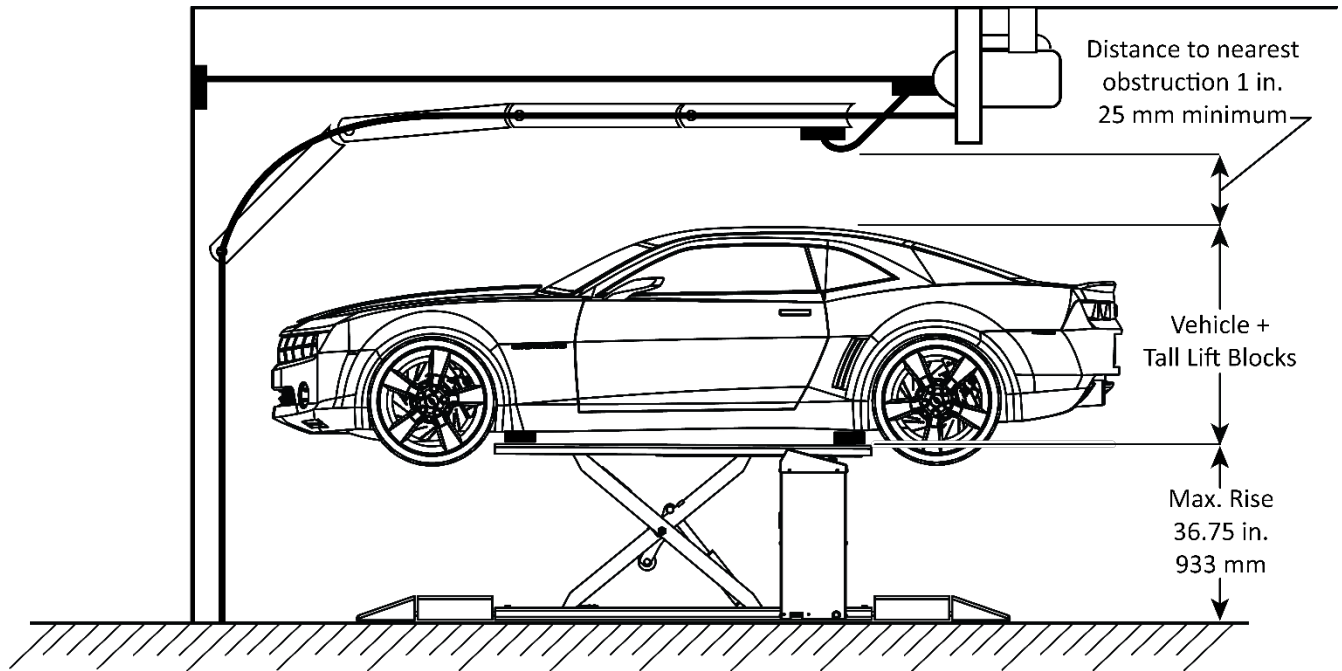

*Drawing not to scale.*

## Concrete Cutouts and New Pours

**Important:** BendPak **strongly** recommends working with a Concrete Specialist to plan and create the Concrete Cutouts for your Flush-Mount Lift.

If you plan to cut into existing concrete to create Cutouts for your Lift, or to remove concrete for a New Pour it is important to understand the following **before** creating Concrete Structures for the MDS-6 Series Lifts:

- **All the MDS-6 Series Lifts** have slightly different dimensions. Pay close attention to the Concrete Cutout/New Pour Dimensions for your specific Lift model.
- **Concrete Cutouts.** The Lifting Frames of a Flush-Mount Lift are installed in a recessed section of the floor, called a Concrete Cutout. This cutout may be made in the existing Concrete if it meets the thickness, compression and condition requirements listed here. If not, then a properly reinforced new pour is required.
- **Drill and Core.** It is critical to determine the thickness and compression strength of the existing Concrete floor. Concrete floors must have a compression strength of at least 3,000 psi to support the Lift. A minimum of 4.25 in. / 108 mm of concrete is required **under** the Lift Frames. Drill and test a core sample to determine if the Concrete in your location meets the minimum requirements specified here.
- **Depth of the Concrete Cutouts MDS-6LPF and MDS-6EXTF.** Concrete Cutouts must be a specific depth below floor level so that the tops of the Lifting Platforms are flush with the floor. See table and diagram below.

Model	Concrete Cutout Recess Depth	Minimum Required Concrete under the Lift Frames
<b>MDS-6-LPF</b>	5.375 in. / 137 mm	4.25 in. / 108 mm
<b>MDS-6EXTF</b>	5.375 in. / 137 mm	4.25 in. / 108 mm

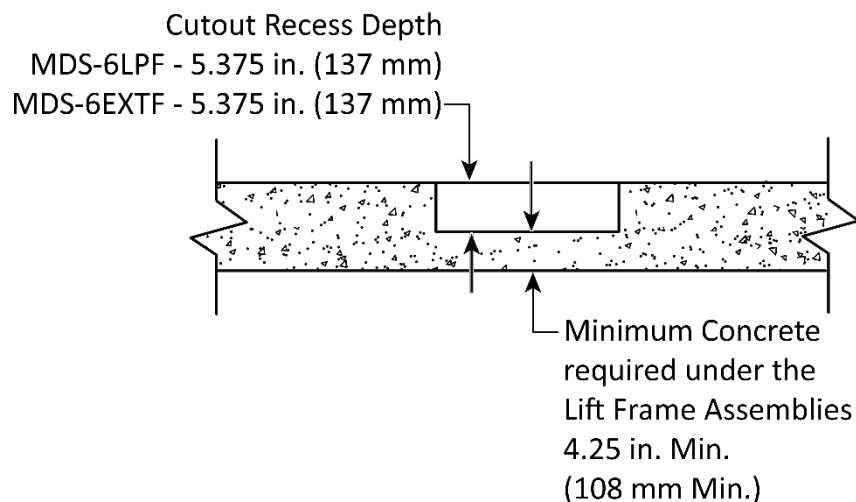

- **Concrete Depth.** The Concrete thickness **below the bottom** of the Lift Frames must be deep enough for the Anchor Bolts to embed; a minimum of 4.25 in. / 108 mm is required.
- **Concrete Curing Time.** New Pour Concrete must cure for a minimum of 28 days before they are strong enough to support Anchor Bolts.
- **Floor Material.** Concrete Cutouts and New Pour must be surrounded by and created in a **Concrete** floor; no other surface (asphalt, dirt, anything else) is acceptable.

- 
- **Never** drill or cut into a Post-Tension slab! Cutting a Post-Tension Cable can result in serious injury or death. A qualified technician is required to identify cable locations prior to cutting or drilling. Post-Tension Slabs in many homes are indicated by a warning stamped into the concrete, often found near the garage door. Older homes may have a plastic or paper sign fastened to the wall. If there are no signs indicating a Post-Tension Slab, undertake a careful examination of the exterior of the slab looking for small circular patching areas about 1.5 in. to 3 in. in diameter, typically 2 to 4-feet apart. These patches indicate the ends of the Post-Tensioned Cables. Another source of information is your local department of Building and Safety. Building and Safety may retrieve the structure plans to determine if the building includes a Post-Tensioned Slab.
  - **Planning.** There are critical decisions to make **before** creating your Concrete Cutouts or New Pour: Lift location, Console location, and how far apart the two Lifting Frames will be. Incorporate your decisions into the Plan you create with your Concrete Specialist.
  - **Cutout Size.** Concrete Cutouts need to be slightly larger than the Frame Assemblies. The values listed on the following pages add about 0.5 inch ( $\approx 12.75$  mm) on all four sides of each Frame Assembly. Pay careful attention to the dimensions listed, as each model has slightly different dimensions.
  - **Hydraulic Hoses, Air Lines, and Return Lines MDS-6LPF and MDS-6EXTF.** Because the Frame Assemblies are recessed, the Air Line, Return Line, and Hydraulic Hoses are recessed as well. Your plan for the Concrete Cutouts or New Pour needs to account for how these Lines will be routed to the Console.

PVC Conduit with a 2.5-inch minimum diameter is commonly used to route the Hydraulic Hoses and Air Lines between the two Frame Assemblies and the Console. If you plan to cut in existing Concrete, then plan for cutting channels between the Frame Assemblies and the Console to fit the PVC Conduit and then cover with Concrete.

Both Frame Assemblies come with rectangular openings for routing the Hydraulic and Air Lines; two per Base, both on the Cylinder end. There is one circular opening in the bottom of each Frame, also on the Cylinder end, which may be used for routing the Hydraulic Hoses, Air Lines, and Return Lines.

- **Lift Location.** Use care when selecting a location for the Lift. Choose a location that allows a straight approach to the lift, without obstructions, and allows access to power and air. Once you create your Concrete Cutouts or a New Pour, the Lift location is fixed.
- **Console Location.** The Console can be installed on either the right or left side of the Lift, but at the Cylinder end of the Frame Assemblies. The supplied hose assemblies allow you to install the Console a maximum of 40 inches (1,016 mm) away from the closest Frame Assembly. You can mount the console further away, but this will require custom fabrication of Hydraulic Hoses, longer Air Lines and more Hydraulic Fluid. Plan accordingly.
- **Distance between Frame Assemblies.** The Frame Assemblies can be from 40 to 46 inches (1,016 to 1,168 mm) apart, allowing you to pick the best width for the Vehicles you will be lifting. Determine the distance you want, then add that to your Planning.
- Use the dimensions shown in the diagrams on the following pages to create New Pour installations or to cut the existing concrete for your installation.

---

## New Concrete Slab Requirements

If the concrete in your Lift location is unsuitable in some way (thickness, compression strength, condition, etc.) then the following recommendations for a new concrete slab are offered. Please read the following concrete recommendations carefully before producing any new Concrete structures for the Lift.

***BendPak strongly recommends consulting a Concrete Specialist early in your planning process for the MDS-6 Lift installation. The recommendations presented in this document are generic in nature and cannot cover all situations. A Concrete Specialist will adjust these recommendations to account for national, state, and local building codes as well as local weather conditions, soil composition, base preparation, load bearing, seismic requirements, and any other structural concerns that may arise.***

- **All properties** of the new Slab are mandatory and must conform to these requirements before the Lift is deemed acceptable.
- **New Concrete Slabs** must be surrounded by and flush with the existing concrete floor.
- **New Concrete Slabs** must be “Keyed-In” around the perimeter of the pour or may be “Tied-in” using Anchor Dowels. See Key-In/Tie-In Detail below.
- **Compressive strength** of the New Pour Concrete Slab is to be 4,000 psi minimum.
- **Minimum ageing** of new Concrete Slabs is 28 Days.
- **Minimum thickness** of the New Pour Concrete Slab is 10 in. (254 mm) for Flush Mount Lifts and 10 in. (254 mm) for surface mount Lifts. See diagrams/recommendations for your specific Lift model.
- **Minimum Width and Length** of the new Concrete Slab, see diagrams/recommendations for your specific Lift Model.
- **Maximum allowed Slope** of New and existing Concrete Slabs is 3-Degrees. Defined as no more than 3/8 in. (9.5 mm) difference over the installation area.
- **Steel reinforcement** use Grade 60 - #4 rebar Ø1/2 in (Ø12.7 mm) Nominal Diameter.
- **Rebar Spacing** as per the diagrams/recommendations on the following pages.
- **Locate reinforcing bars** away from any anchor positions or at an elevation that allows you to avoid drilling into reinforcing steel while installing the Expansion Anchors for the Lift.
- **Certified strength documentation** for New Pours should be obtained from the firm who supplies the Concrete Mixture at the time of the pour.
- Do **not** install the Lift on any surface other than Concrete conforming to the minimum compressive strength, aging, reinforcement, and thickness stated in these requirements.
- **Never** install the Lift over an expansion joint.
- All Lift Anchors **must** be a minimum of 6 in. (152 mm) away from any expansion seams, control joints or other inconsistencies in the Concrete.
- **Never** install the Lift on hand-mixed Concrete.
- Do **not** install the Lift on a secondary floor level or on any ground floor with a basement beneath without written authorization from the building Architect and prior approval of BendPak Inc.
- **Never** drill or cut into a post tensioned slab. Seek qualified personnel to identify cable locations prior to cutting or drilling



**MDS-6EXTF** – Use the following diagram as recommendations for creating a New Pour Slab with Concrete Cutouts for the **MDS-6EXTF** only.

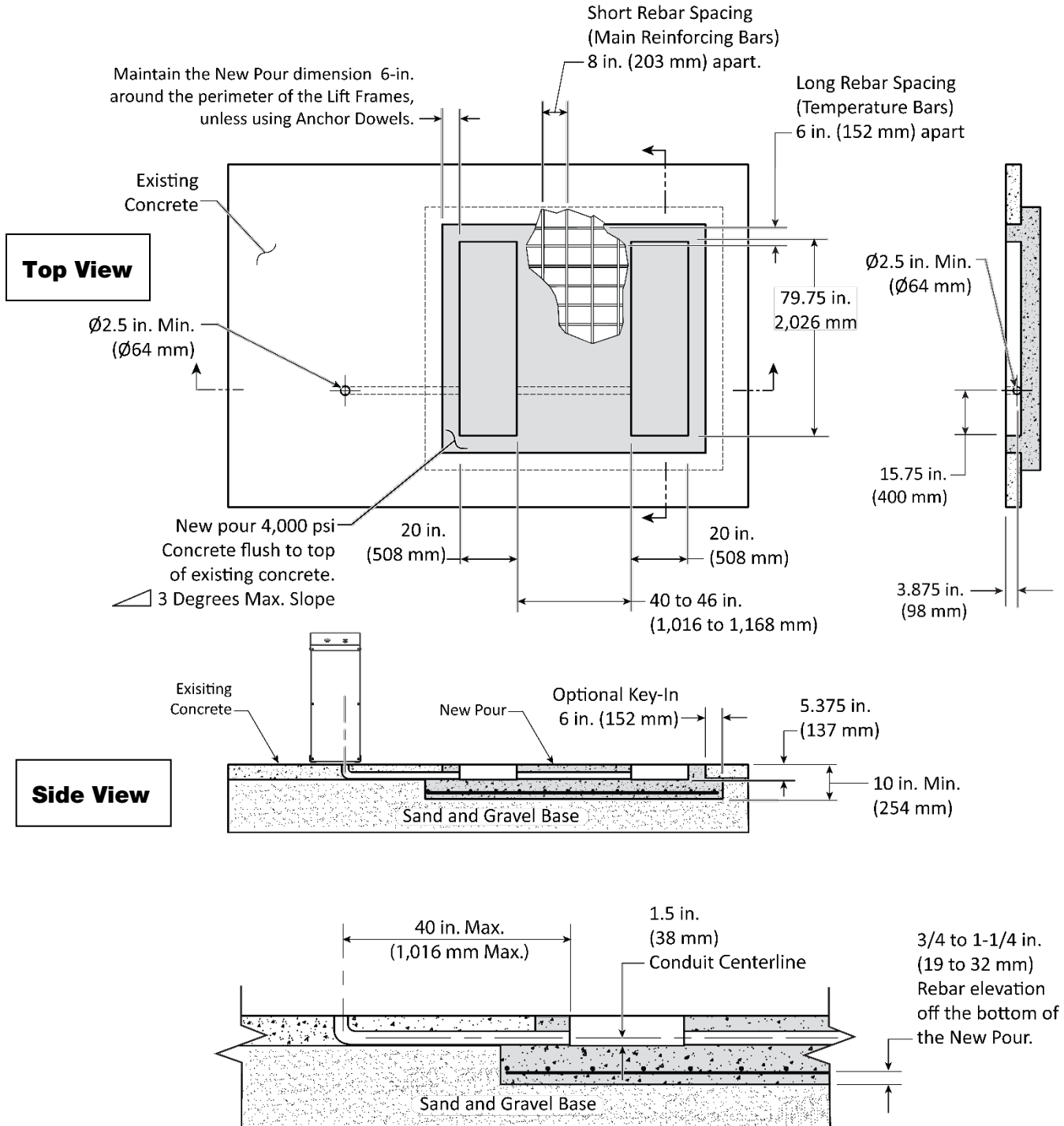

- Notes:
1. New Slabs must be either Keyed-In or Tied-In to the surrounding Concrete.
  2. All rebar is Grade 60-#4 Ø1/2 (12.7 mm) Nom. Dia.
  3. Rebar grid and elevation tolerance ±1 in. (25 mm).

*Do not scale drawing. Not all components shown.*

The Flush-Mount Lift layout dimensions for the **MDS-6EXTF** are:

- **Length.** The Length of each Lifting Platform is 78.75 inches / 2,000 mm; add 1 inch / 25 mm to get **≈79.75 inches / 2,025 mm.**
- **Width.** The Width of each Frame is 19 inches / 484 mm; add 1 inch / 25 mm to get **≈20 inches / 509 mm.**
- **Depth.** The Lowered height of each **MDS-6EXTF** Lifting Frame Assembly is **5.24 in. / 126 mm.** Make the depth for each frame **5.375 in. / 137 mm** minimum.
- **Distance Between.** The two Lifting Platform Assemblies can be from **40 to 46 in. / 1,018 to 1,168 mm** apart. You do **not** add an extra inch to this value. Determine this width based on the Vehicles you will be lifting.
- **Distance to Console.** The hose assemblies supplied allow the Console to be up to **40 in. / 1,016 mm** from the nearest Frame Assembly on the left or right side, but only on the cylinder end of the Lift Frames. You can mount the console further away, but this will require custom fabrication of Hydraulic Hoses, longer Air Lines and more Hydraulic Fluid. Plan accordingly.

**NOTICE**

If you create your Concrete Cutouts or a New Pour and then change your mind about the Distance between the Ramps or find out you made an error on a dimension, it is very difficult to fix. BendPak recommends double checking your plan several times before cutting or pouring Concrete Cutouts. Mark the lift outline in chalk or tape on the floor and attempt a dry run with the Vehicle to verify that the placement and dimensions are correct before you cut.

**BendPak strongly recommends working with a concrete specialist to plan and create Concrete Cutouts and/or Slabs for the MDS-6 Lift.**

The Figure below details the **MDS-6LPF** mounted in a New Pour.

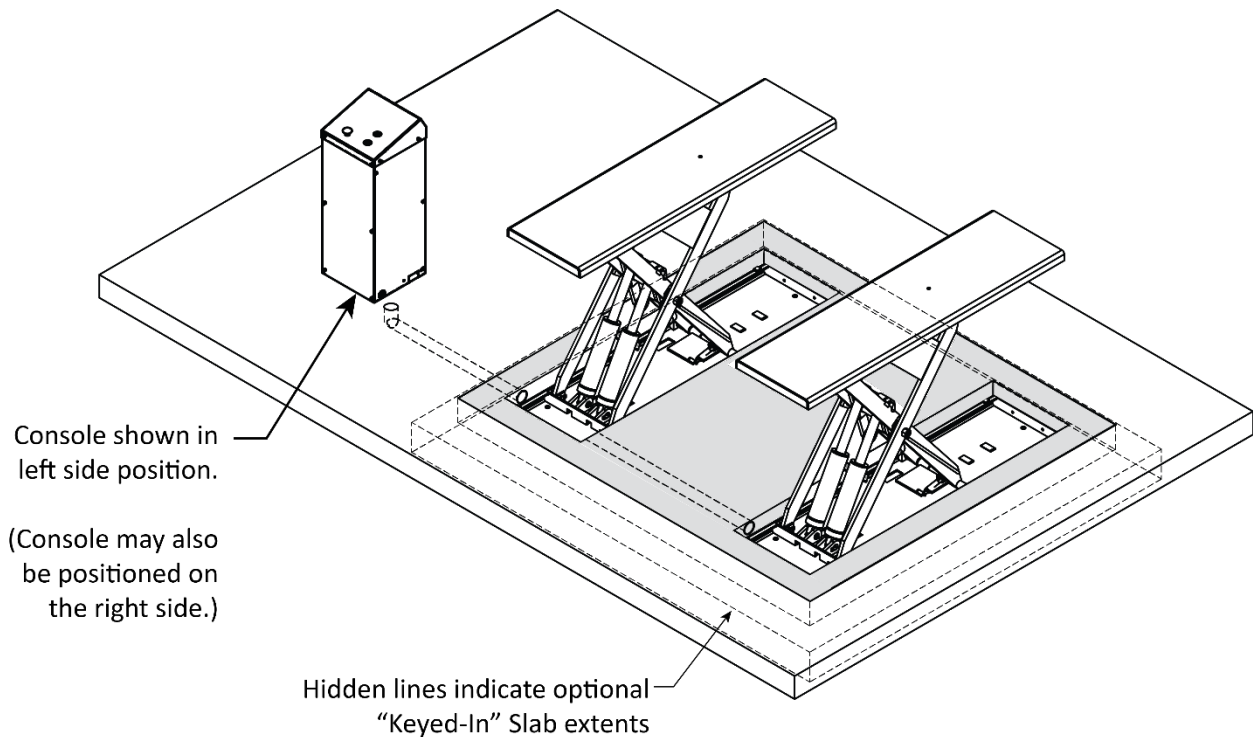

*Do not scale drawing. Not all components shown.*

## MDS-6LPF

Use the following diagram as recommendations for creating New Pour Slab with Concrete Cutouts for the **MDS-6LPF** only.

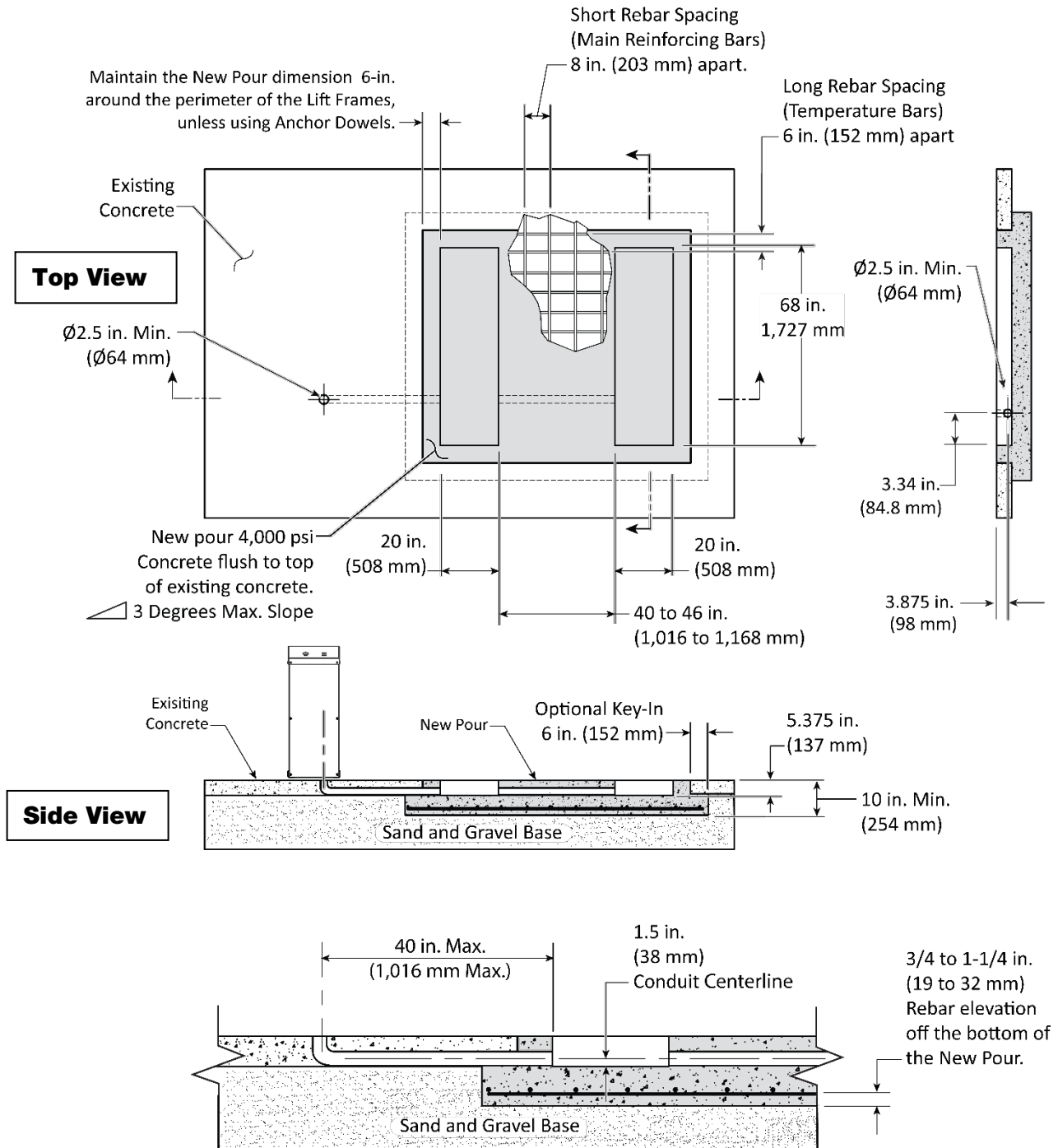

**Notes:**

1. New Slabs must be either Keyed-In or Tied-In to the surrounding Concrete.
2. All rebar is Grade 60-#4 Ø1/2 (12.7 mm) Nom. Dia.
3. Rebar grid and elevation tolerance ±1 in. (25 mm).

*Do not scale drawing. Not all components shown.*

---

The Flush-Mount Lift dimensions for the **MDS-6LPF** are:

- **Length.** The Length of each Lifting Platform is 67 inches / 1,701 mm; add 1 inch / 25 mm to get **≈68 in. / 1,726 mm.**
- **Width.** The Width of each Frame is 19 inches / 484 mm; add 1 inch / 25 mm to get **≈20 in. / 509 mm.**
- **Depth.** The Lowered Height of each Frame Assembly is **5 in. / 127 mm.** Make the depth for each frame **5.375 in. / 136.5 mm** minimum. Do **not** add an extra inch to this value.
- **Distance Between.** The two Bases can be from **40 to 46 in. / 1,018 to 1,168 mm** apart. Do **not** add an extra inch to this value. Determine this width based on the Vehicles you will be lifting.
- **Distance to Console.** The supplied hosing allows the Console to be up to **40 in. / 1,016 mm** from the nearest Base. You do **not** add an extra inch to this value.

**NOTICE**

If you create your Concrete Cutouts or New Pour and then change your mind about the Distance between the Ramps or find out you made an error on a dimension, it is difficult to fix. BendPak recommends double checking your plan several times before cutting or pouring Concrete Cutouts. Mark the Lift outline in chalk or tape on the floor and attempt a dry run with the Vehicle to verify that the placement and dimensions are correct before you cut.

***BendPak strongly recommends working with a concrete specialist to plan and create Concrete Cutouts and/or Slabs for the MDS-6 Lift.***

## MDS-6LP and MDS-6EXT

Use the following diagram as recommendations for creating a New Pour Concrete Slab for the **MDS-6LP and MDS-6EXT**.

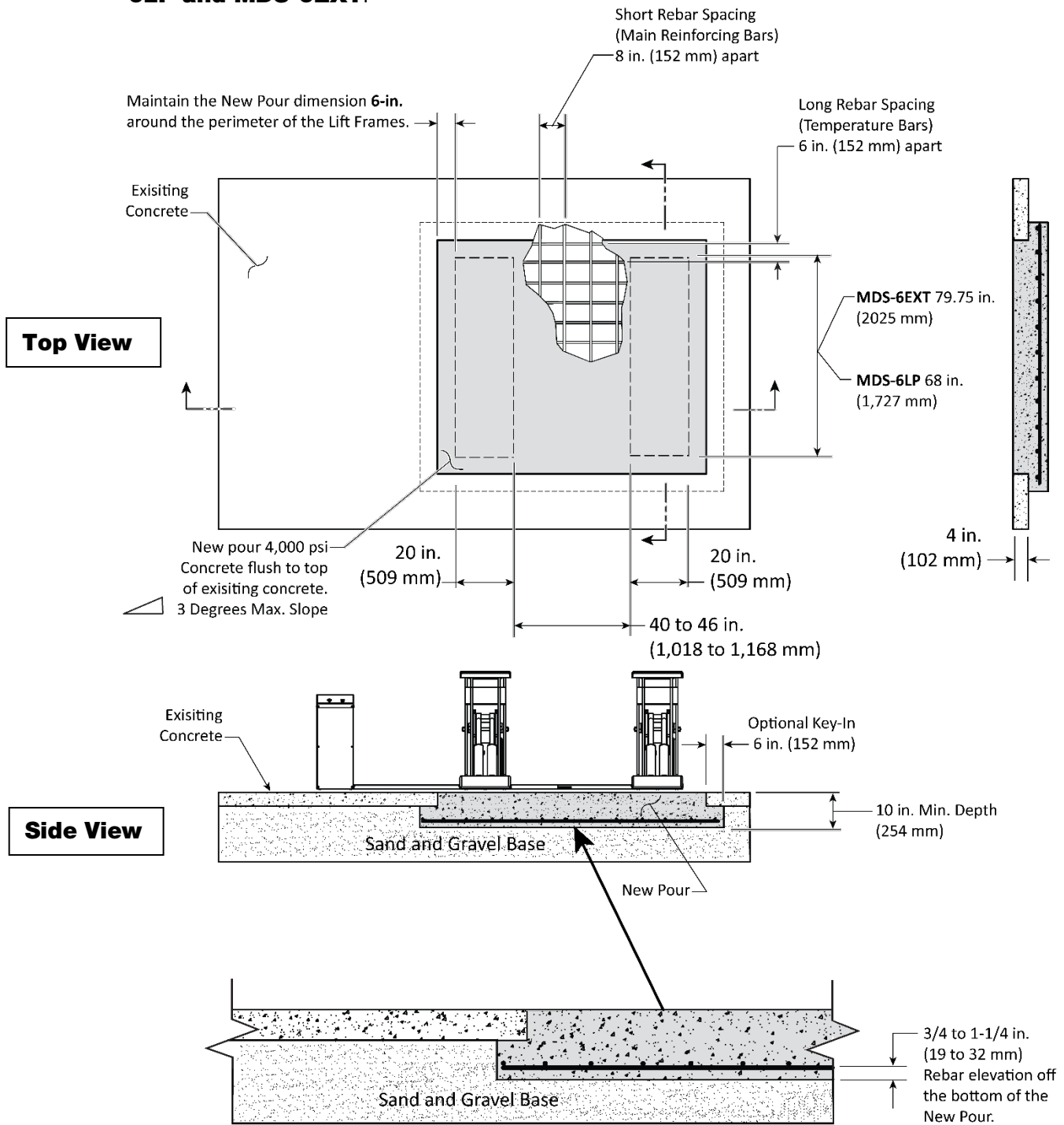

**Notes:**

1. New Slabs must be either Keyed-In or Tied-In to the surrounding Concrete.
2. All rebar is Grade 60-#4  $\varnothing 1/2$  (12.7 mm) Nom. Dia.
3. Rebar grid and elevation tolerance  $\pm 1$  in. (25 mm).

*Do not scale drawing. Not all components shown.*

The figure below details an **MDS-6LP** mounted on a New Pour.

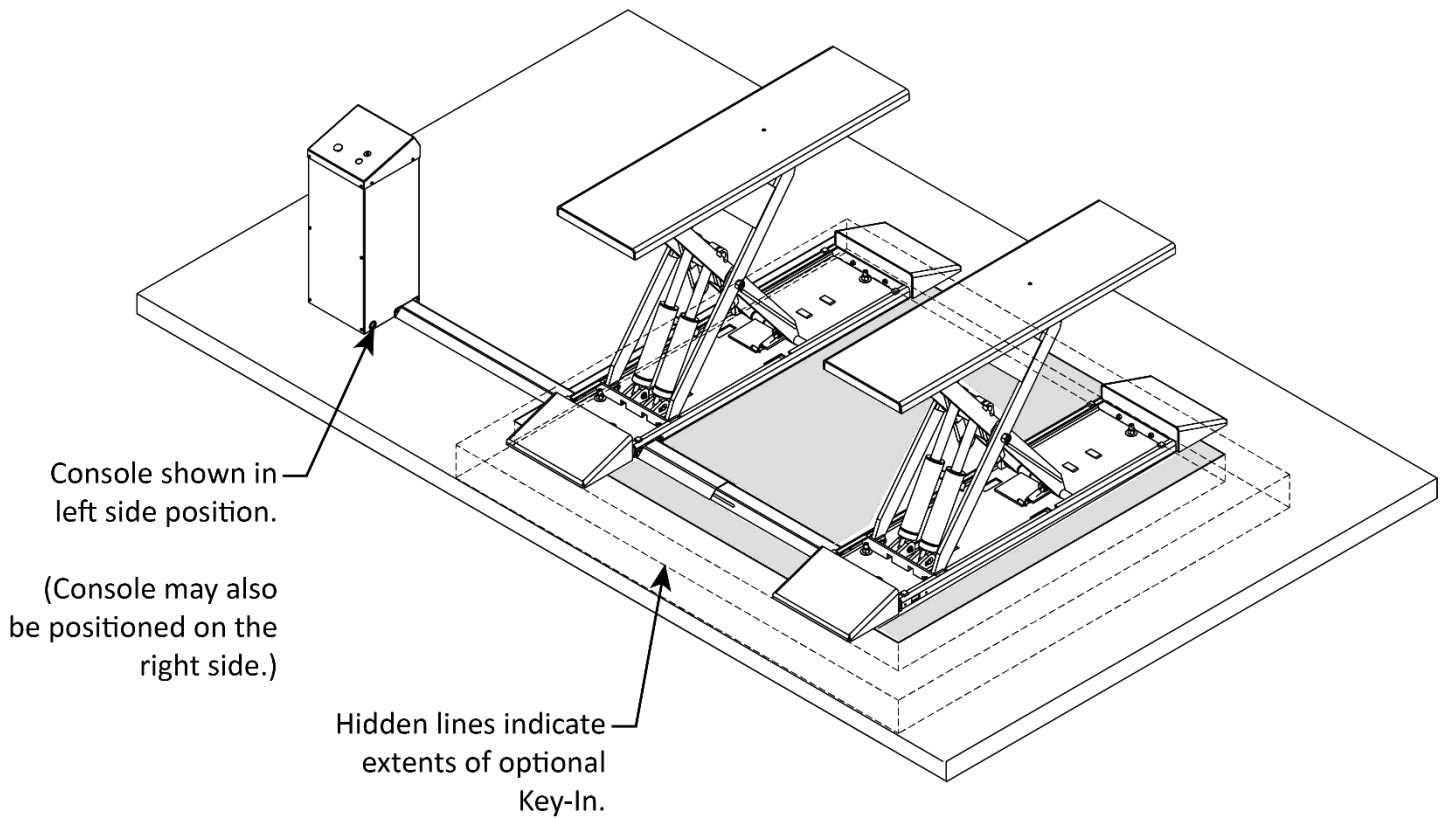

*Do not scale drawing. Not all components shown.*

**BendPak strongly recommends working with a concrete specialist to plan and create Concrete Cutouts and/or Slabs for the MDS-6 Lift.**

## Create a Floor Plan

Make sure to plan out, in advance, where the Lift and Console are going to be installed:

- **Clearance.** Make sure there is clearance on all sides and above the Lift site.
- **Console.** The Console must be near the Lift; it can be installed on either the left or right side but only on the cylinder end of the Ramps. The Hydraulic Hoses that come with the unit can support up to 40 inches between the Lift and the Console.
- **Operator.** The operator at the Console **must** have a full, unobstructed view of the Lift.
- **Power.** The Console must be positioned near an appropriate power source.
- **Set up Chalk Line Guides.** Create Chalk Line Guides for the Lift to make sure the Lift is properly aligned.

### To create Chalk Line Guides:

1. Decide where you want to locate the Lift. Keep in mind the Console needs to be within 40 inches.
2. Create an Alignment Chalk Line where you want the front of the Lift. Note that the drawing below does not show the Ramps.

Make the Alignment Chalk Line longer than the width of the Platforms and the space between.

3. Add two more Chalk Lines perpendicular to the Alignment Chalk Line and the same distance apart that you want your Platforms to be (within the range of 40 in. to 46 in. / 1,018 mm to 1,168 mm).

The following drawing shows the Alignment Chalk Line at the front of the Lift and Left and Right Chalk Lines perpendicular to the Alignment Chalk Line.

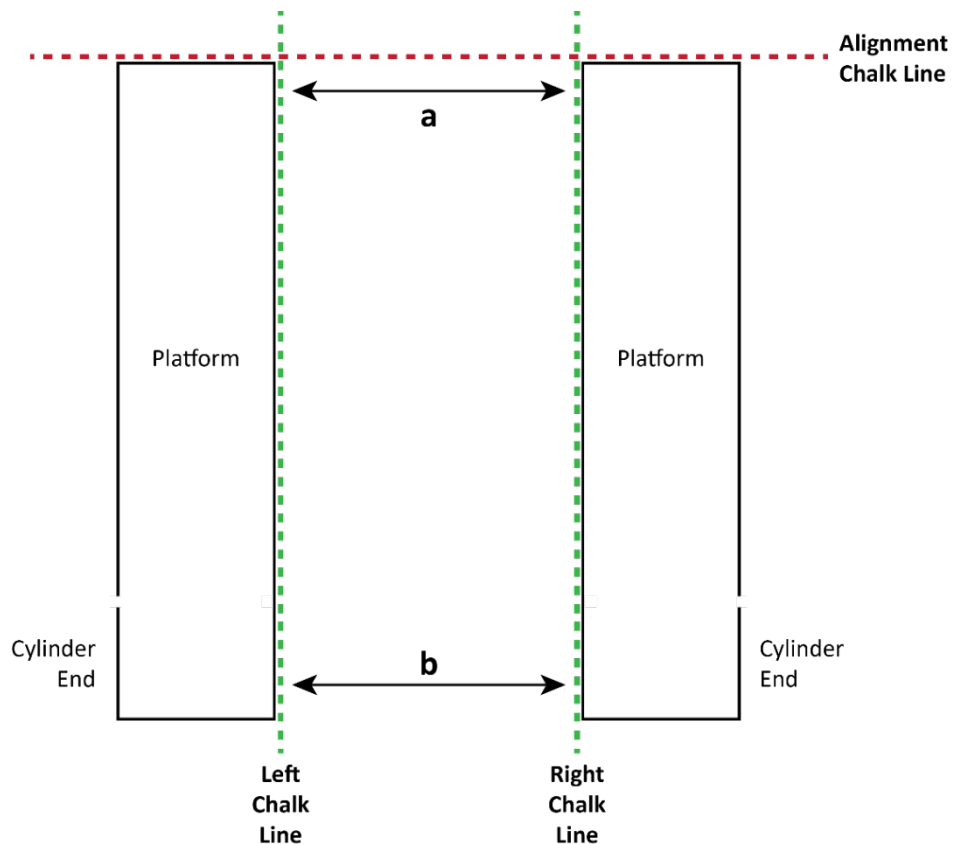

*Not to scale. Not all components shown. Ramps not shown.*

- 
4. Move the two Platforms into position where the Left and Right Chalk Lines intersect the Alignment Chalk Line.

**Tip**

If you are installing the Lift over a pit, you can skip the Left and Right Chalk Lines and just use the edges of the pit as guides. Do not overhang the pit.

5. Measure the distance between the two Platforms at points **a** and **b**; the two Platforms need to be the same distance apart at both points.

If **a** and **b** are not the same, adjust the Platform locations; make sure they are the same distance apart and parallel to each other (or the pit, if installing over a pit).

6. When the Platforms are in their correct locations, they may be anchored into place.

## Lift the Platforms off the Bases

You must raise the Platforms off their Bases to anchor the Lift into position and connect the Hydraulic Hose, Air Line, and Return Line. **Be sure to leave the Lift on a Safety Lock when you raise it.**

**Important:** BendPak recommends using the Eyebolt that comes with the Lift to raise the Platforms off the Bases.

 **WARNING** BendPak strongly recommends using **at least three people** to lift the Platforms off their Bases: one person on each end to hold down the Base and one person to operate the Forklift or Shop Crane to raise the Platform. **Use care when raising the Platforms off their Bases; they are heavy and sometimes difficult to hold.**

 **WARNING** You **must** always wear OSHA-approved (publication 3151) Personal Protective Equipment when installing the Lift: leather gloves, steel-toed boots, eye protection, back belts, and hearing protection are **mandatory**.

### To lift the Platforms off the Bases:

1. Retrieve the Lifting Eyebolt from the Parts Box and install in the M10 threaded hole in the middle of the Platform you want to raise.
2. Attach a rope, chain or Industrial Sling to the Eyebolt and use a Forklift or Shop Crane to raise the Platform off its Base.

 **WARNING** Do not put any part of your body under the Platform while it is being lifted. Use a wood 2 x 4 or other suitable device to hold the Base in position until the Platform is secure on the top safety lock.

 **WARNING** The Lifting Frame Assemblies are heavy. Do not lift the Platforms without assistance.

**Tip**

Once the Platform and Base are separated by more than half an inch (~13 mm), you may use industrial slings (straps) around each end to continue raising the Platform off the Base. You can continue using the Eyebolt if you prefer.

- 
3. When the Platform is above the top Safety Lock, lower it back down onto the top Safety Lock. Leave it on that top Safety Lock.
  4. Remove the Eyebolt from the first Platform, install the Eyebolt on the second Platform. Perform the same procedure on the second Platform.

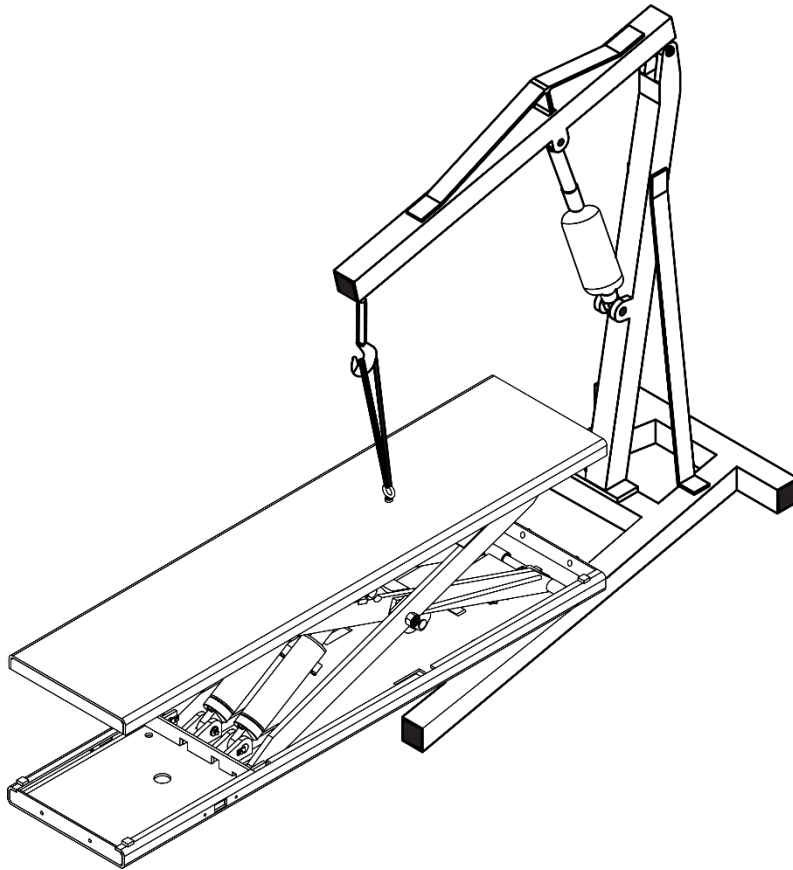

5. Verify the bases are within the chalk line guides before proceeding.

## About Effective Embedment

Anchor Bolts (also called Wedge Anchors) get their holding strength from how far down into the Hole the Anchor Bolt's Expansion Sleeve presses into the Concrete (called Effective Embedment) and how forcefully the Expansion Sleeve presses into the Concrete (based on the width of the hole and how much Torque is applied).

The further down into the Hole you get the Expansion Sleeve, the greater the Effective Embedment and thus the greater the holding strength of the Anchor Bolt. The hole must be drilled the same width as the Anchor Bolt with no wobbling. The correct amount of Torque is a range; too little Torque and the Anchor Bolts hold with less strength, too much Torque and you could damage the Concrete and lessen the Anchor Bolt's holding strength.

**Note:** Some people confuse Effective Embedment with *Nominal* Embedment, which is how far down into the Hole the *bottom* of the Anchor Bolt is. The two are **not** the same; Nominal Embedment does not tell you anything about the holding strength of the Anchor Bolt.

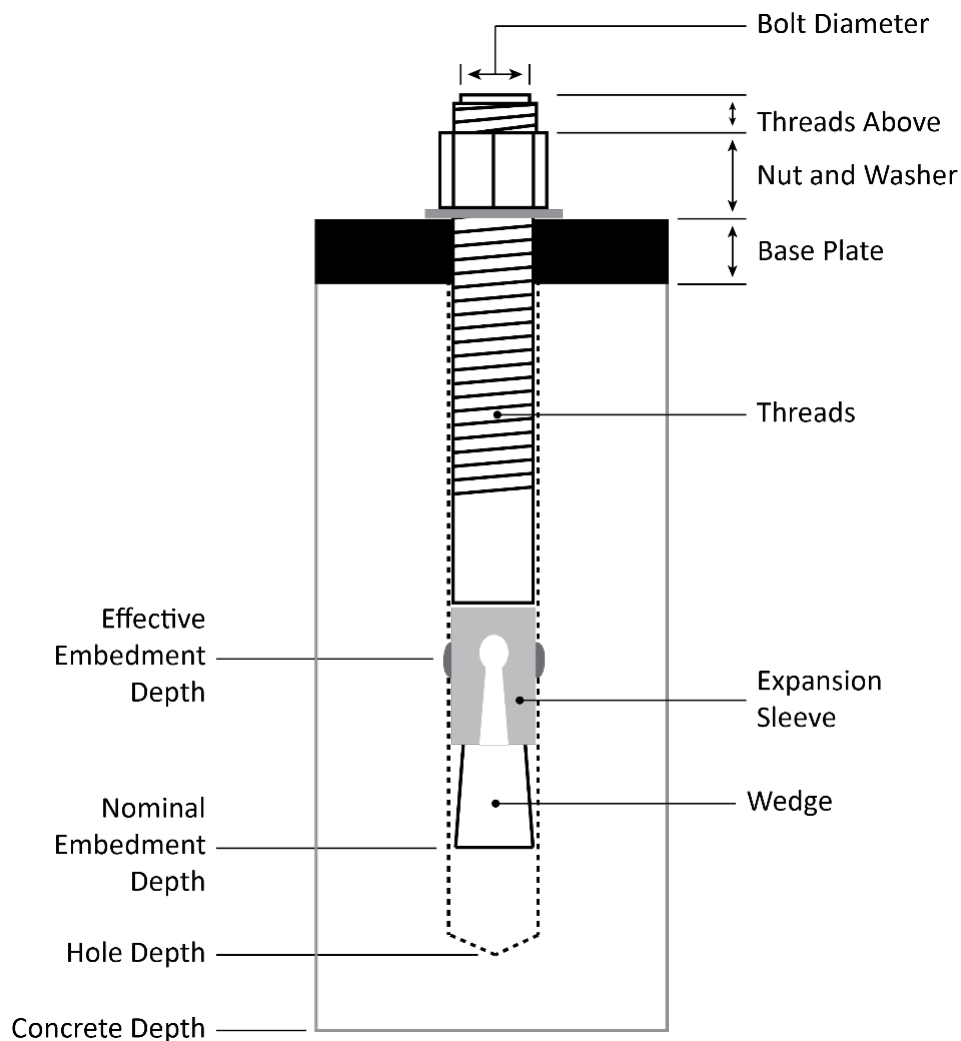

Make sure to carefully follow the specifications and instructions in the following procedure.

**⚠ WARNING** Use only the Anchor Bolts that came with your Lift. Only install your Lift on a Concrete floor. Make sure to get the correct amount of Effective Embedment and use the correct amount of Torque.

---

## Anchor the Bases

Each Ramp Assembly Base has four holes **MDS-6EXT/F** or three holes on the **MDS-6LP/F** for anchoring into the Concrete.

Before you anchor your Lift, make sure the two Platforms are correctly aligned in the chalk lines. BendPak recommends double checking the work done when creating your Chalk Line Guides.

 **CAUTION** Poor alignment can impact how the Lift raises and lowers. Take the time now, before you anchor the Lift in place, to verify it is correctly aligned.

### Anchor Bolt specifications:

- **Length:** 5 inches
- **Diameter:** .75 inch
- **Effective embedment depth:** 2.75 inches, minimum
- **Anchor torque:** 85 – 95 ft. lbs.

 **WARNING** Use only the ALI-certified Anchor Bolts that came with your Lift. If you use components from a different source, you void your warranty and compromise the safety of everyone who installs or uses the Lift.

 **WARNING** Only install your Lift on a Concrete surface. If you install a Lift on asphalt or any other surface, or your Concrete or Anchor Bolts do not meet these specifications, it could lead to product damage, Vehicle damage, personal injury, or even loss of life.

BendPak Lifts are supplied with installation instructions and concrete fasteners meeting the criteria as prescribed by the latest version of the American National Standard “Automotive Lifts – Safety Requirements for Construction, Testing, and Validation.”

***Lift buyers are responsible for conforming to all regional, structural, and seismic anchoring requirements specified by any other agencies and/or codes, such as the Uniform Building Code and/or International Building Code.***

 **WARNING** ***Only use the factory-supplied parts that came with your Lift.*** If you use components from a different source, you void your warranty and compromise the safety of everyone who installs or uses the Lift.

 **WARNING** Do **not** install your Lift on a surface with 3° of slope or greater. A slope in excess of 3° can lead to property damage, personal injury, or death. Small differences in floor level may be compensated for by proper shimming, but any slope in excess of 3° will have a negative effect on the Lift. If the concrete at the installation site has an excessive slope, create a concrete cutout, and pour a new concrete slab. Consult a concrete specialist in such a case.

The following figure details the locations of the Anchor Bolt holes for the **MDS-6EXT/F**.

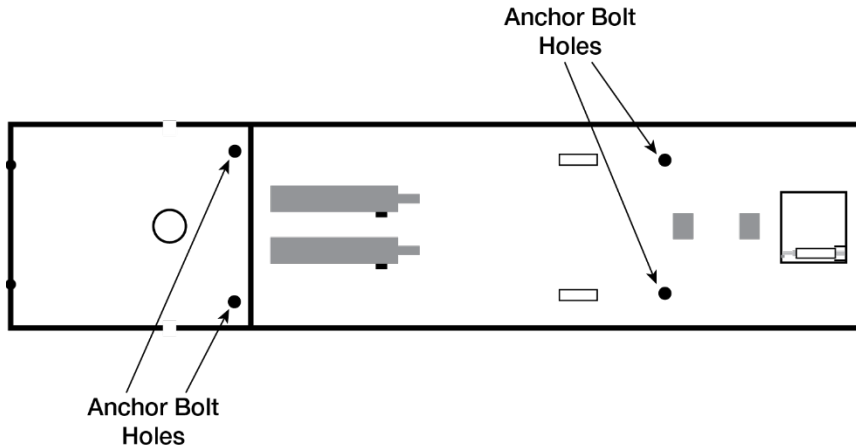

The following drawing shows the locations of the Anchor Bolt holes for the **MDS-6LP/F**.

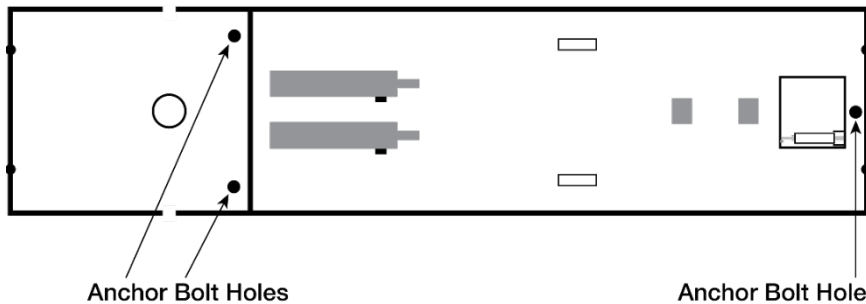

*Not to scale. Not all components shown.*

### To anchor the Bases:

1. Retrieve the Anchor Bolts (5530307), with Flat Washers and Hex Nuts from the Parts Box.
2. Verify the Ramp Bases are where you want them.

Once you anchor the Bases into place, it is difficult to change the location. Once the Anchor Bolts are torqued into position, they are not easily removed. BendPak strongly recommends double checking the Bases are in the correct location **before** anchoring the Bases into place.

3. Using the holes in the Bases as guides, drill the holes for the Anchor Bolts.

**Note:** If you prefer, you can mark the Anchor Bolt Hole locations, move the Platforms out of the way, drill the holes, and then move the Platforms back into position over the holes.

Drill straight down, perpendicular to the concrete. Do not let the Drill wobble.

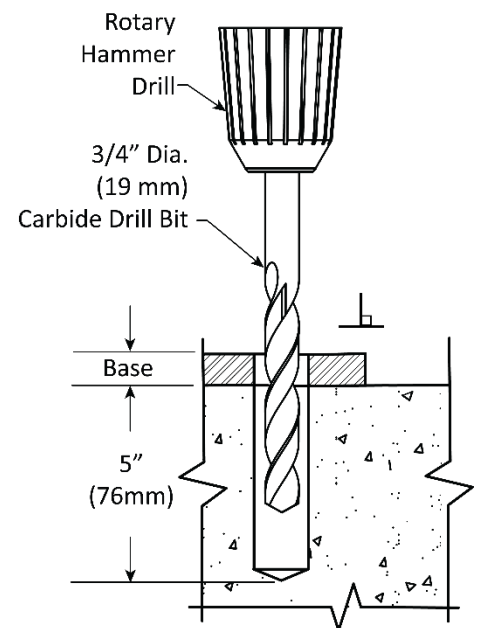

Use a Concrete Drill (conforming to ANSI B212.15). The diameter of the Drill Bit **must** be the same as the diameter of the Anchor Bolt. If you are using a 3/4 inch diameter Anchor Bolt, for example, use a 3/4 inch diameter drill bit.

**Note:** BendPak recommends drilling a pilot hole first. If the final hole size is to be Ø.75 in. / Ø19 mm, drill a Ø.375 in. / Ø9.5 mm to Ø.5 in. / Ø12.7 mm pilot hole first. Pilot holes allow straighter drilling by removing the material directly in the center of the final drill. This reduces the amount of force required to keep the drill straight and perpendicular to the floor. Verify the drill flutes are at least 4.25 in / 108 mm long to aid in removal of the debris from the drill hole.

**⚠ WARNING** Always wear appropriate eye protection and protective gear.

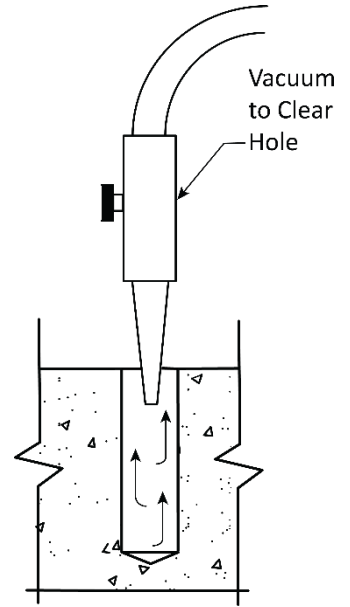
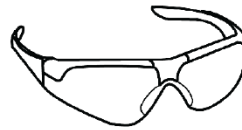

4. After drilling, use a vacuum to completely clean the hole. If a vacuum is not available, you could use a wire brush, hand pump, or compressed air. Do **not** ream the hole. Do **not** make the hole any wider than the Drill Bit made it.
5. If you have moved the platforms to the side, move them back into position over the new anchor holes.
6. Verify the Washer and Nut are in place, then insert the Anchor Bolt into each hole, then tap it down into the hole.

The Expansion Sleeve of the Anchor Bolt may prevent the Anchor Bolt from passing through the hole in the Base; this is normal. Use a Hammer or Mallet to tap the Expansion Sleeve through the Base and into the hole.

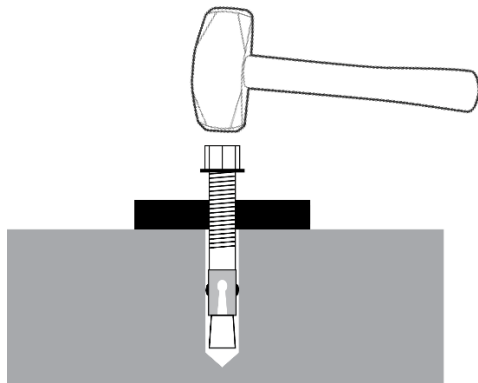

Even using a Hammer or Mallet, the Anchor Bolt should only go into the hole part of the way; this is normal. If the Anchor Bolt drops in with little or no resistance, the hole is too wide.

Once past the hole in the Base, the Anchor Bolt eventually stops moving down into the hole as the Expansion Sleeve contacts the sides of the hole; this is normal.

7. Hammer or Mallet the Wedge Anchor the rest of the way down into the hole.

Stop hammering when the Washer is snug against the Base. Do not torque until after levelling the Lift.

## Level the Lift Platforms

The Lift Ramp Assemblies must be parallel and square to each other before leveling and shimming can be effective. Both Ramps **must** be resting on a Safety Lock to perform this procedure.

1. Verify the Ramp Assemblies are still within the chalk lines and parallel to each other by measuring the A and B dimensions. Adjust their positions until the A and B dimensions are equal. Refer to the figure on the right.
2. Begin by leveling lengthwise front to back. The Lift Ramps will be leveled to the highest point on the concrete floor. To find the highest point, use a four-foot level across the top of the Ramps or across the base of the Lift Ramps. Observe the bubble position to determine the direction and magnitude of the slope pointing to the highest area.

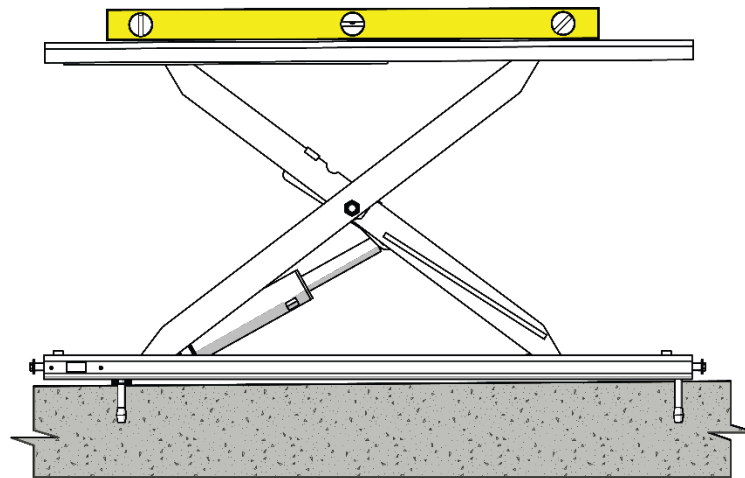
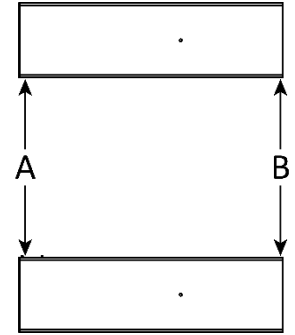

3. Beginning at the corner closest to the highest point, shim each Anchor Bolt hole location until each Lift Ramp is Level front to back.

Three Anchor Bolts are located on the Base of the Ramps, two at the rear and one at the front of each frame.

**Important:** Use slotted Shims around each Anchor Bolt location to help prevent the concrete from cracking near the Anchor Bolts. Refer to the figures on the right.

Level both Lift platforms.

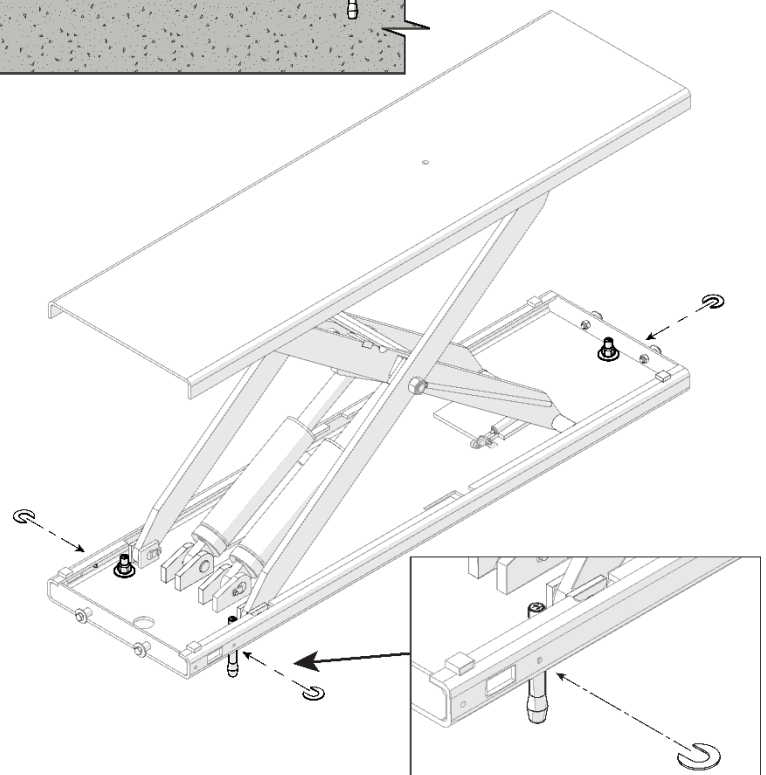

- Once the Ramp Assemblies are level front to back, level each Lift Platform laterally across the inside and outside of the Ramp Assemblies.

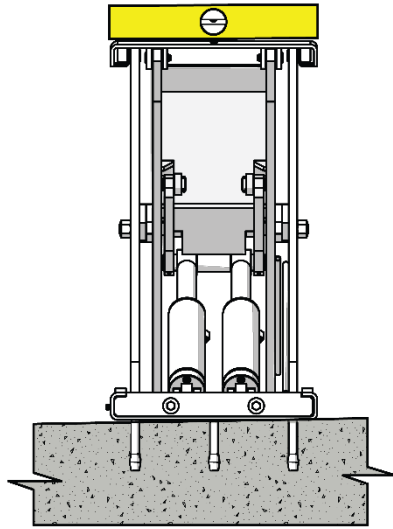

- Then verify the level condition across the platforms and correct with shims as required.

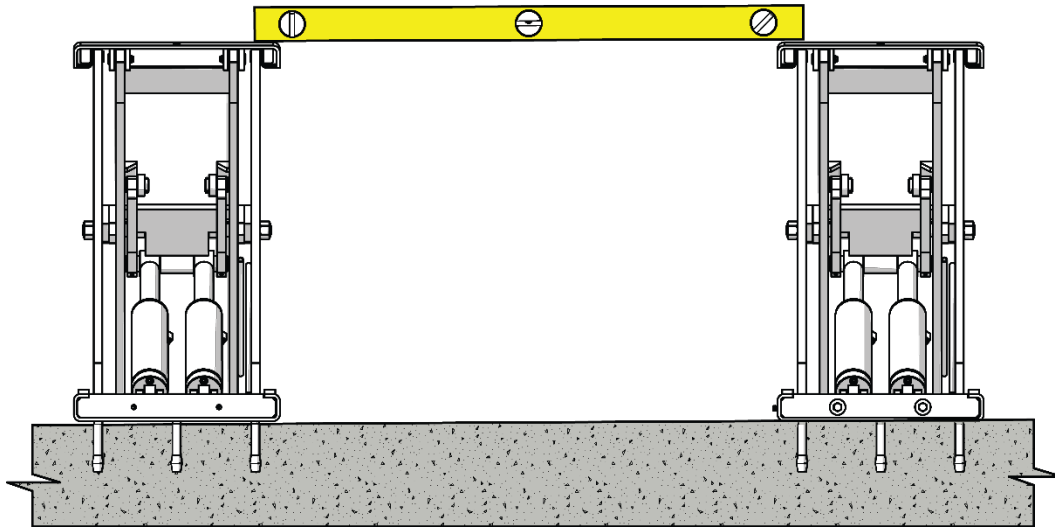

- Wrench each Nut **clockwise** to the recommended installation torque, 85 – 95 ft-lbs. using a Torque Wrench.

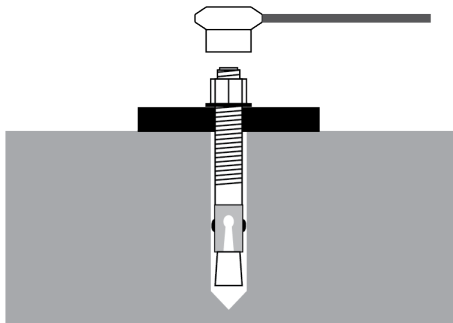

**Important:** Do **not** use an impact wrench to torque the Anchor Bolts.

Wrenching the Nut forces the Wedge up, pushing out the Expansion Sleeve and pressing it tightly against the Concrete.

---

## Grouting the Bases

If no shims were used, there is no requirement to grout the Bases of the Lift. Using Shims to level the Lift Platforms creates a void between the Lift Base and the existing concrete. These voids must be filled to support the downward force exerted by the Slide Blocks as they travel along the base. Tuck Point a non-shrinking structural grout or cement to fill the voids and provide this support. A variety of structural grouts and cements are available Quikrete® Fast Set® non-shrink grout is one such option.

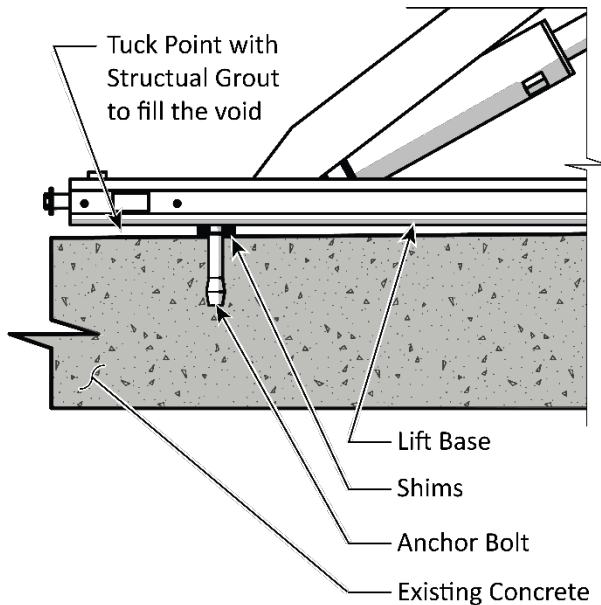

Allow the material to cure to the manufacturer's specifications before applying weight to the Lift.

## Assemble and Anchor the Console

The Hydraulic Hoses, Air Line, and Return Line require the Console to be within 40 inches of the cylinder end of the Lift on either the left or right side.



### Tip

If the ideal Console installation is further than 40 inches from your Lift, custom Hydraulic Hoses must be fabricated that are long enough to reach the Lift from the desired location. You may be able to obtain these Hoses from a local hydraulics shop. Longer Air and Return Lines will also be required. **For safety purposes, the Console operator must have a clear line of sight to the Lift during operation.**

The following procedure describes assembling and anchoring the Console. It is possible to defer the anchoring operation until the ideal location has been determined. It is easier to change the Console location later if it is not anchored. Delaying the anchoring provides an opportunity to evaluate how well the first location functions in the facility.

Return to this section and follow the instructions for anchoring.

**To assemble and anchor the Console:**

1. Select a site for the Console that permits operator to have a full, unobstructed view of the Lift.

The Console may be mounted on either the left or right side of the Lift, up to 40 inches away from the Cylinder end in a direct line from the square opening in the Lift Base where the Hydraulic and Air Lines will be routed.

2. Using the Console Base dimensions provided here, sketch with chalk, pencil or tape the outline of the console on the concrete. Verify that the chosen location allows an unobstructed view of the Lift and will not interfere with opening the Vehicle doors or cause any other interference.

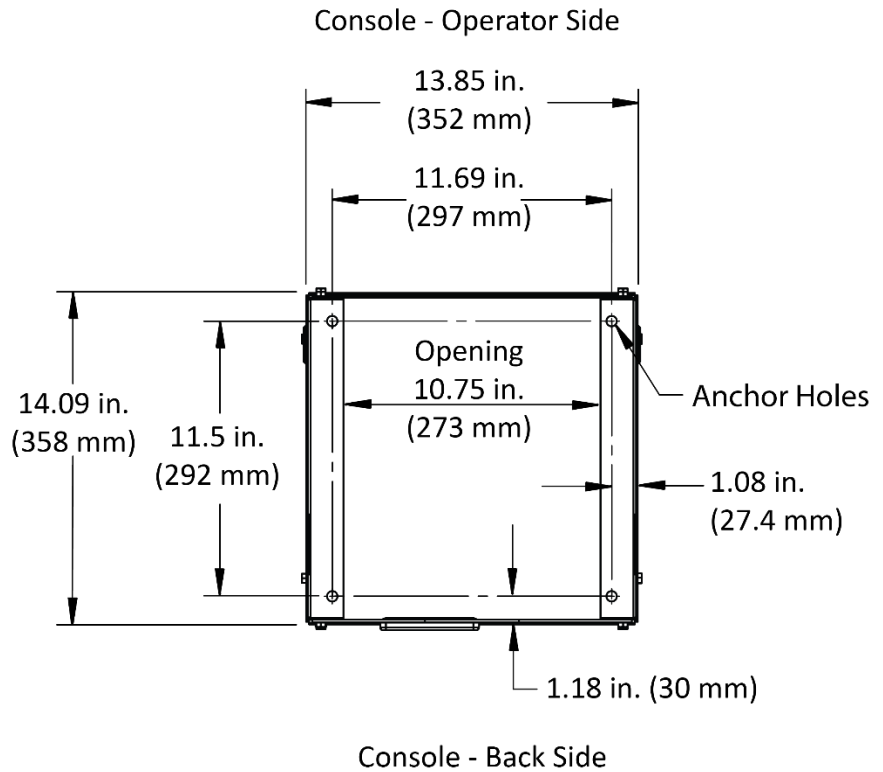

*Not to scale. Not all components shown.*

3. Open the Power Unit Console Box and retrieve the Rear, Left Hand, and Right-Hand sides of the Console as well as four M6 x 12mm Hex Head Bolts.

4. On a flat level surface, place cardboard or rags down to prevent marring the paint and assemble as shown to the right.

Note the orientation of the sides and tighten the Hex Head Bolts. Do not insert the top two Hex Head Bolts.

5. Stand the three sides up and move the assembly over the chalk outline made in step 1 above.

6. Retrieve the Console Door from the packaging and 4 more M6 x 12 Hex Head Bolts.

7. Assemble the Console Door to the three sides and tighten the Hex Head Bolts Hand Tight to keep the assembly square.

8. Verify that the Console is lined up on the Chalk outline on all four sides.

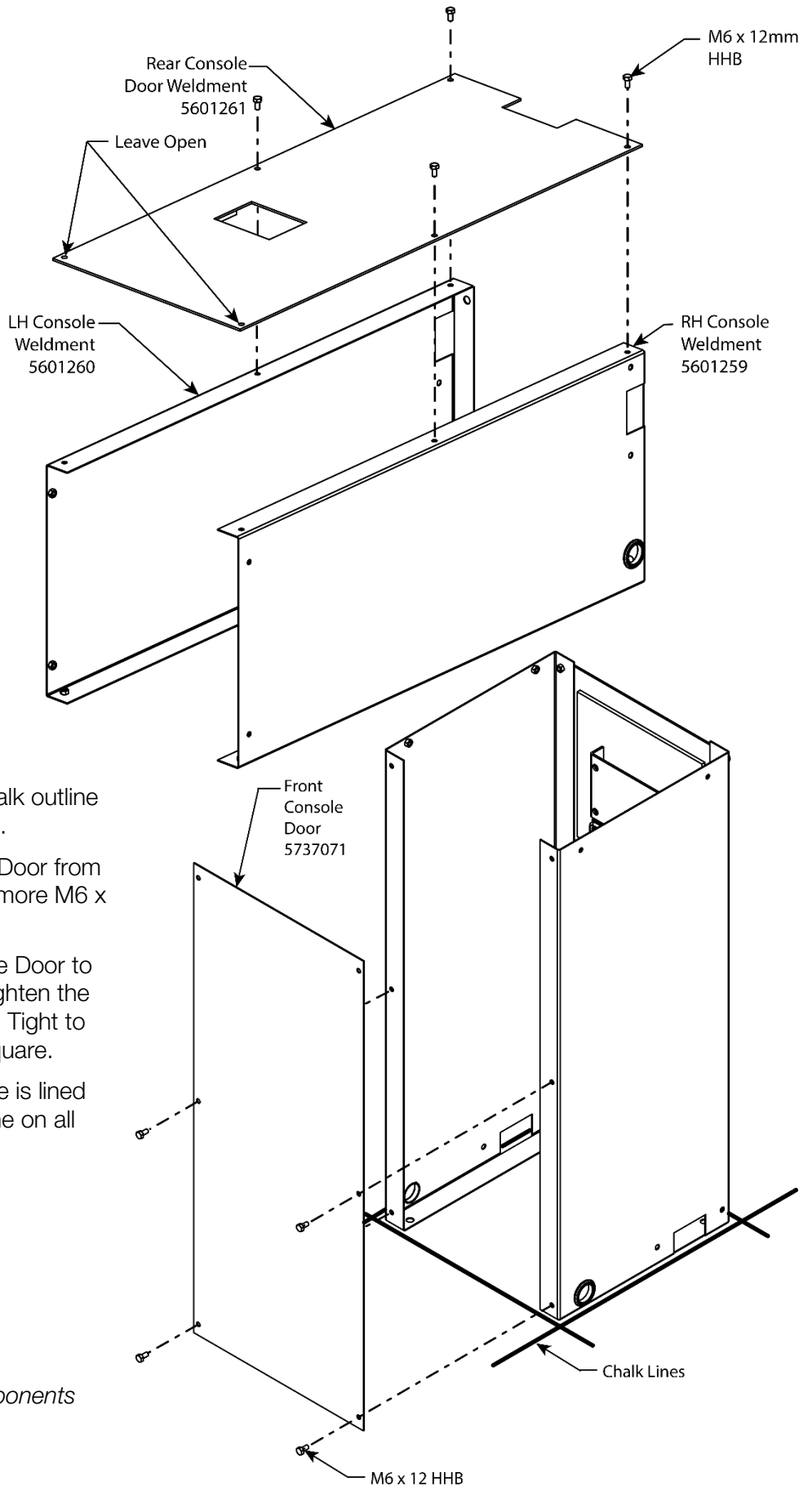

*Not to scale. Not all components shown.*

**Note:** There are four mounting holes in the bottom flange of the Console. Only two of the four holes are required to be anchored. BendPak recommends installing them diagonally from each other.

**⚠ WARNING** Always wear appropriate eye protection and protective equipment.

- Using the holes in the base as a guide, drill two holes 3/8 in. diameter by 3 in. deep into the Concrete.

Drill into the concrete straight; do not let the drill wobble. Use a Carbide Concrete Drill Bit (conforming to ANSI B212.15).

**Note:** BendPak recommends marking the holes with the Drill through the console base. Then move the base out of the way to finish drilling the holes to the 3 in. depth. This will help ensure that the holes are straight and to the correct depth.

- Clean the dust and debris from the holes. Use a wire brush, vacuum, hand pump, or compressed air. Do **not** ream the hole. Do **not** make the hole any wider than the drill bit made it.

**⚠ WARNING** Always wear appropriate eye protection and protective gear.

- Move the Console back over the holes just drilled.
- Remove the four Hex Head Bolts and the Front Console Door. Set these parts aside where they will not be damaged. This allows access to the inside of the console to tap in the Anchors.
- Retrieve the 3/8-16 Expansion Anchors, a 3/8 in. Washer and Nut from the Console packaging.
- Make sure the Washer and Nut are in place, then insert the Anchor Bolt into the mounting hole in the Console base and through into the hole just drilled in the Concrete.

The Expansion Sleeve of the Anchor Bolt may prevent the Anchor Bolt from passing through the hole in the Base; this is normal. Use a hammer or mallet to push the Expansion Sleeve through the Base and into the hole.

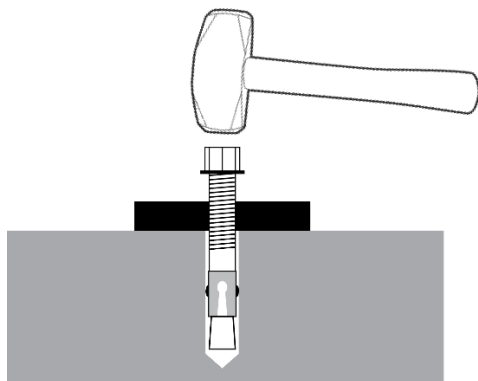
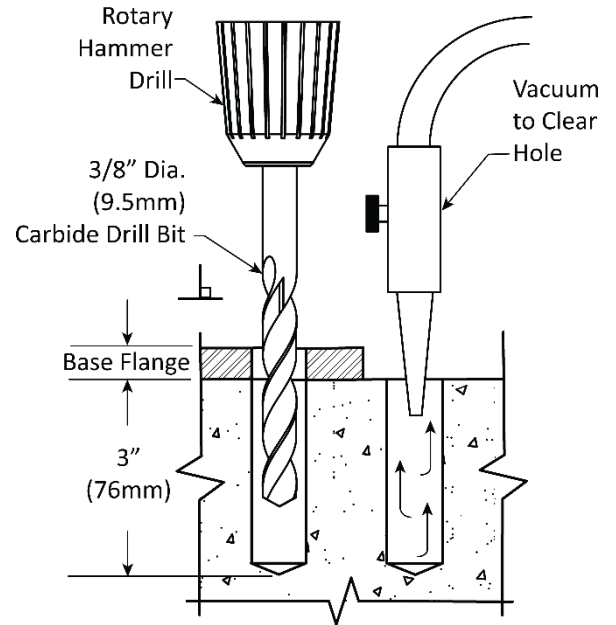

Even using a hammer or mallet, the Anchor Bolt should only go into the hole part of the way; this is normal. If the Anchor Bolt drops in with little or no resistance, the hole is too large.

Once past the hole in the Console Base, the Anchor Bolt eventually stops going down as the Expansion Sleeve contacts the sides of the hole; this is normal.

9. Hammer or mallet the Wedge Anchor the rest of the way down into the hole.

Stop hammering when the Washer is snug against the Base.

10. Wrench each Nut **clockwise** to the recommended installation torque, 10 - 15 ft lbs., (13.5 -20 N-m) using a Torque Wrench.

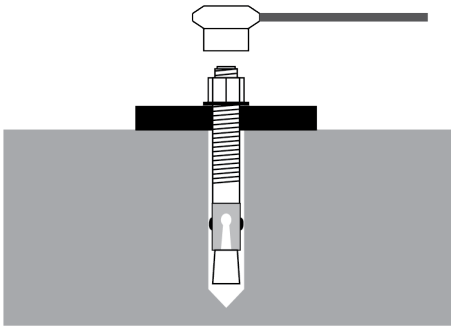

**Important:** Do **not** use an impact wrench to torque the Anchor Bolts.

Wrenching the Nut forces the Wedge up, pushing out the Expansion Sleeve and pressing it tightly against the Concrete.

11. There is no need to install the Console Top (5215857) until the Power Unit with its wiring and pushbuttons are ready to be connected. See **Connect and Prepare the Power Unit.**

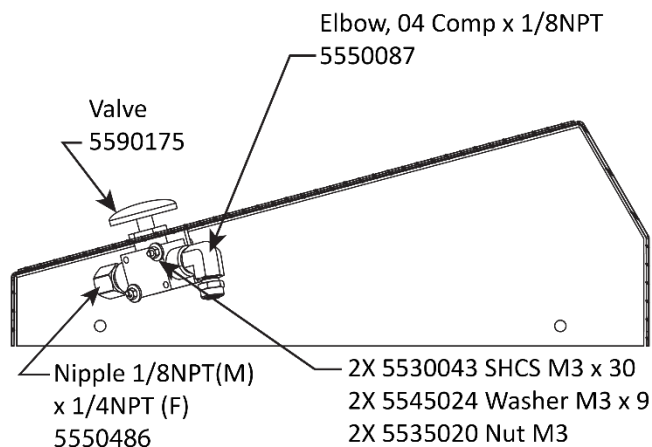
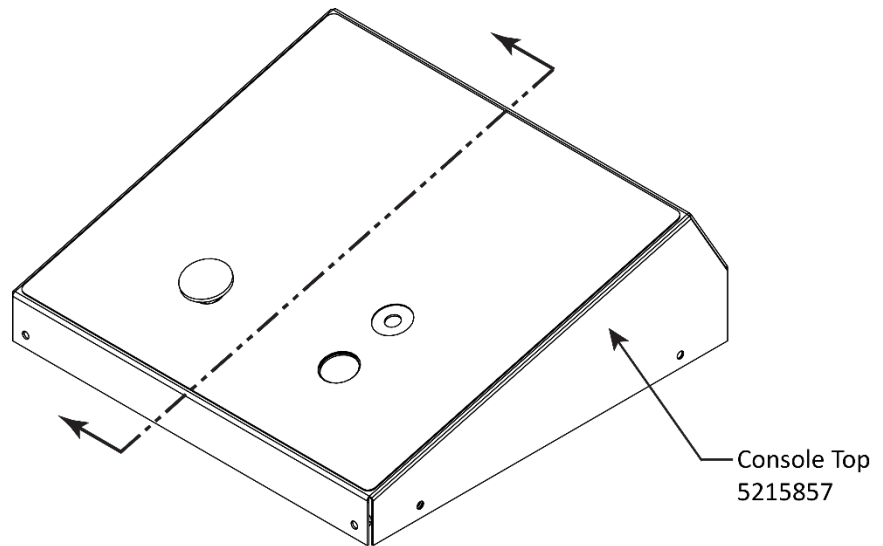

---

## Installing the Power Unit

This section describes how to mount the Power Unit in the Console. You do **not** need an Electrician to **mount** the Power Unit, but you do need an Electrician to **connect** the Power Unit and its controls.

**Important:** Do not connect the Power Unit to the Hydraulic System or to the power source at this point in the installation; those connections will be made later.

To support a wide variety of applications, the Power Unit could be one of multiple Power Units that are available. Because of this, the Power Unit that came with your Lift may look slightly different from the diagrams in this Manual.

Refer to **Connect and Prepare the Power Unit** for Electrical installation information and specific information about the Power Unit that came with your Lift.

The Power Unit **must** be mounted on the Mounting Bracket in the Console.

### To mount the Power Unit:

1. Find the four supplied M8 x 20 Hex Head Bolts from the Console packaging.



**Tip** The Power Unit is heavy. BendPak recommends having one person hold the Power Unit while a second person bolts it into place.

2. The Power Unit has a Mounting Bracket with four holes that match the four holes in the Rear Console Weldment. Make sure to use all four holes to secure the Power Unit.
3. Push one of the Bolts through a hole in the Power Unit Mounting Plate, through and into the Console Weldment, Thread the Bolt into the weldment hand tight.
4. Repeat Step 3 for the other three Bolts.
5. Go back and tighten all four Bolts.

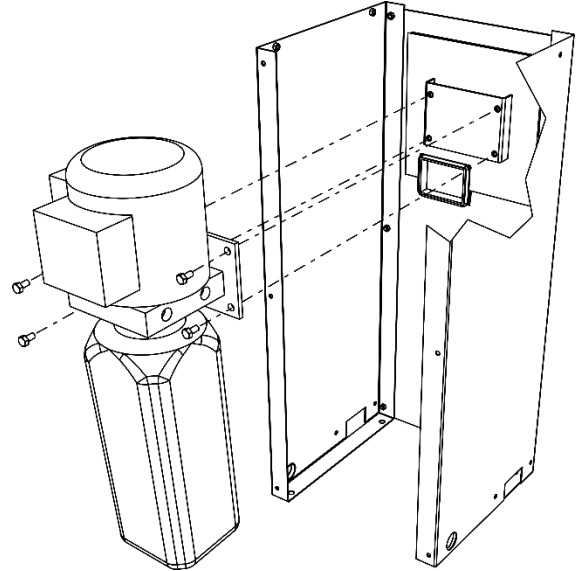



## IMPORTANT! PLEASE READ NOW



### Hydraulic Fluid Contamination

Hydraulic Fluid Contamination poses a **significant issue** for your Lift; contaminants such as water, dirt, or other debris can get into the Hydraulic Hoses and Fittings on your Lift, making your new Lift inoperable and unusable.

Your Lift is shipped with clean components; however, BendPak strongly recommends that you take secondary precautions and clean all Hydraulic Hoses and Fittings prior to making connections. It is better and less costly to take these extra steps now so that you do not need to take your Lift out of service later to fix issues that could have been prevented at the time of the installation.

There are several ways to clean Hydraulic Hoses and Fittings:













- **Compressed air.** Use an air compressor to blow out contaminants from each Hydraulic Hose and Fitting prior to installation. Clean, dry air is preferred. Wear eye protection (safety glasses, goggles, or face shield) when using compressed air for cleaning. Never point an air hose nozzle at any part of your body or any other person.
- **Fluid flushing.** If the Hydraulic Fluid is clean and compatible with the system fluid, you can flush Hoses and Fittings to create turbulent flow and remove particulates. Always ensure that the fluid itself is contaminant-free.

Some additional steps that will help keep the Hydraulic Fluid clean:

- **Remove old thread seal tape.** Some ports on the Hydraulic Cylinders are shipped with temporary plugs secured with thread seal tape, so make sure to thoroughly remove any leftover thread seal tape that may inadvertently enter the Hydraulic System.
- **Use a liquid thread sealant only.** Teflon paste-type thread sealant or Loctite™ 5452 thread sealant is recommended for all NPT Fittings. Do not over tighten NPT Fittings or they may crack. Do **not** use thread seal tape on flare-end JIC 37-degree bevel Fittings or ORB O-Ring Fittings.
- **Always use clean equipment.** If you use a dirty bucket or funnel to transfer the Hydraulic Fluid into the Hydraulic Fluid Reservoir, the contaminants will likely be introduced into the Fluid. When using cleaning rags, use a lint-free rag.
- **Proper storage.** Keep the Hydraulic Fluid sealed in its container until ready for use. Store the Fluid in a clean, dry, and cool area.
- **Cover the Hoses and Fittings.** Before installation, do not leave the ends of the Fittings exposed; the same applies for Hydraulic Hoses. As a rule, keep the Hydraulic Hoses and Fittings capped and kept in a clean area until ready for use.
- **Filter the new Hydraulic Fluid.** Just because it is new does not necessarily mean it is *clean*. Use an offline filtration cart or kidney loop system to make sure the Hydraulic Fluid is clean before being transferred into the Reservoir (even using a heavy-duty nylon mesh screen is better than trusting what is left at the bottom of the barrel).
- **Avoid mixing different types of Hydraulic Fluid.** If Hydraulic Fluid needs to be replaced, make sure to flush the Hydraulic System of the old Hydraulic Fluid before you add the replacement fluid; do not mix the two together.

---

## Hydraulic System Warnings:

-  **WARNING** Failure to observe these warnings can result in serious personal injury including, in rare cases, death.
-  **WARNING** The Hydraulic Hoses and connections **must** be inspected before any attempt to raise a Vehicle is made.
-  **WARNING** Double check to **verify** all Hydraulic Hose connections and fittings, including unused auxiliary port plugs on the Power Unit, the Flow Divider, the Cylinders and anywhere else in the Hydraulic System are tightened.
-  **WARNING** The Power Unit is a Hydraulic Pump capable of developing pressures in excess of 5,000 psi (345 BAR). A pressure relief valve is used to set the pressure to the desired level. Tampering with, adjusting, modifying, or removing the relief valve is extremely dangerous and is not recommended. Only trained Hydraulics Technicians should adjust the relief valve, using calibrated Hydraulic Pressure gauges to assure the proper pressure setting is achieved.
-  **WARNING** Changes to the output pressure may render the power unit incompatible with pressure limitations of other components in the Hydraulic Circuit. This may cause catastrophic failure of those components, and could result in property damage, serious personal injury, or death.
-  **WARNING** The Hydraulic System can contain high pressure which, if suddenly released, can cause severe injury or death.
-  **WARNING** Do **not** attempt to connect or disconnect Hydraulic Hoses while the equipment is loaded or while a Vehicle is on the Lift, or the Hydraulic System is under pressure.
-  **WARNING** Keep bare hands away from Hydraulic Fluid; always wear gloves when handling Hydraulic Fluid, Cylinders or Hydraulic Hoses.
-  **WARNING** When handling Hydraulic Fluid, always observe the safety instructions from the manufacturer.
-  **WARNING** **Always** promptly clean any Hydraulic Fluid spills. If a leak is the source of the spill, lockout the Lift to prevent use until the Hydraulic System is repaired.
-  **WARNING** Do **not** attempt to service the Power Unit through the rear panel. Only access the Power unit through the Front of the Console.
-  **WARNING** If you choose to change the Hydraulic Hose lengths, **the two hoses supplying the Hydraulic Lift Cylinders' length must be within 5% of each other.** The MDS-6 Lift is a Hydraulically Balanced Lift. If the hose lengths vary by more than 5% there is a risk of the Platforms rising unevenly. Choose a certified Hydraulic Hose fabrication facility to assemble the replacement hoses.

---

## About Thread Sealants

Liquid Thread Sealant lubricates and fills the gaps between the Fitting threads and leaves no residue that could contaminate the Hydraulic Fluid. Other types of Thread Sealants (like Teflon Tape) can shred during installation or removal and eventually enter the Hydraulic System. Thread Sealant can be used with most Hydraulic Fittings, although you only need to use it with NPT connectors.

### To apply Thread Sealant:

6. Apply the thread sealant when the ambient temperature is between +46.5°F to +70°F (+8°C to 21°C) Make sure the fittings and connectors are clean and dry.
7. If you are adding Thread Sealant to a Fitting or connector that has already been used with a different sealant, use a wire brush to thoroughly remove the old sealant before adding more.
8. Skipping the top thread, apply a small amount of Thread Sealant to the next four threads of the Fitting.

**⚠ WARNING** Always wear the proper protective equipment when handling Thread Sealant.

You only need a small amount because the sealant spreads to the other threads as it is tightened into place.

If you put too much, the excess liquid will be pushed out when the Fitting is tightened; use a rag to wipe the excess.

9. Tighten the Fitting into the connector; do **not** over tighten the Fitting.
10. Allow the manufacturer-recommended curing time before pressurizing the system.

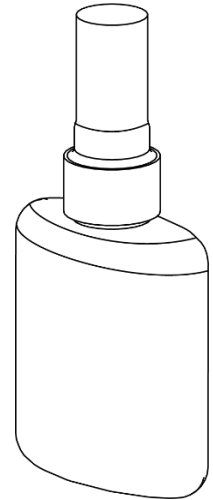

## Connect the Hydraulic Hoses

Hydraulic Hoses provide Hydraulic Fluid to the Hydraulic Cylinders, which is used to raise and lower the Platforms.

**⚠ WARNING** If you choose to change the Hydraulic Hose lengths, **the two hoses supplying the Hydraulic Lift Cylinders' length must be within 5% of each other.** The MDS-6 Lift is a Hydraulically Balanced Lift. If the hose lengths vary by more than 5% there is a risk of the Platforms rising unevenly. Choose a certified Hydraulic Hose fabrication facility to assemble the replacement hoses.

The Lift comes with seven Hydraulic Hoses:

- **Four Short Hydraulic Hoses** (10 inches / 254 mm, two per Frame Assembly) routed from the bottom of the Hydraulic Cylinders to a Tee connector.
- **One Medium Hydraulic Hose** (18 inches / 458 mm) routed from the Power Unit (inside the Console) to the **In** connector on the Flow Divider at the bottom of the Console.
- **Two Long Hydraulic Hoses** (139 inches / 3,552 mm): routed from the Hydraulic Tee on each Frame Assembly to the Console and finally to the **Out** Port on the Flow Divider.

The following figure below displays the general arrangement of how Hydraulic Hoses are routed to the Hydraulic Cylinders. Your Flow Divider may look different, but it will also have one input connector and two output connectors, as shown.

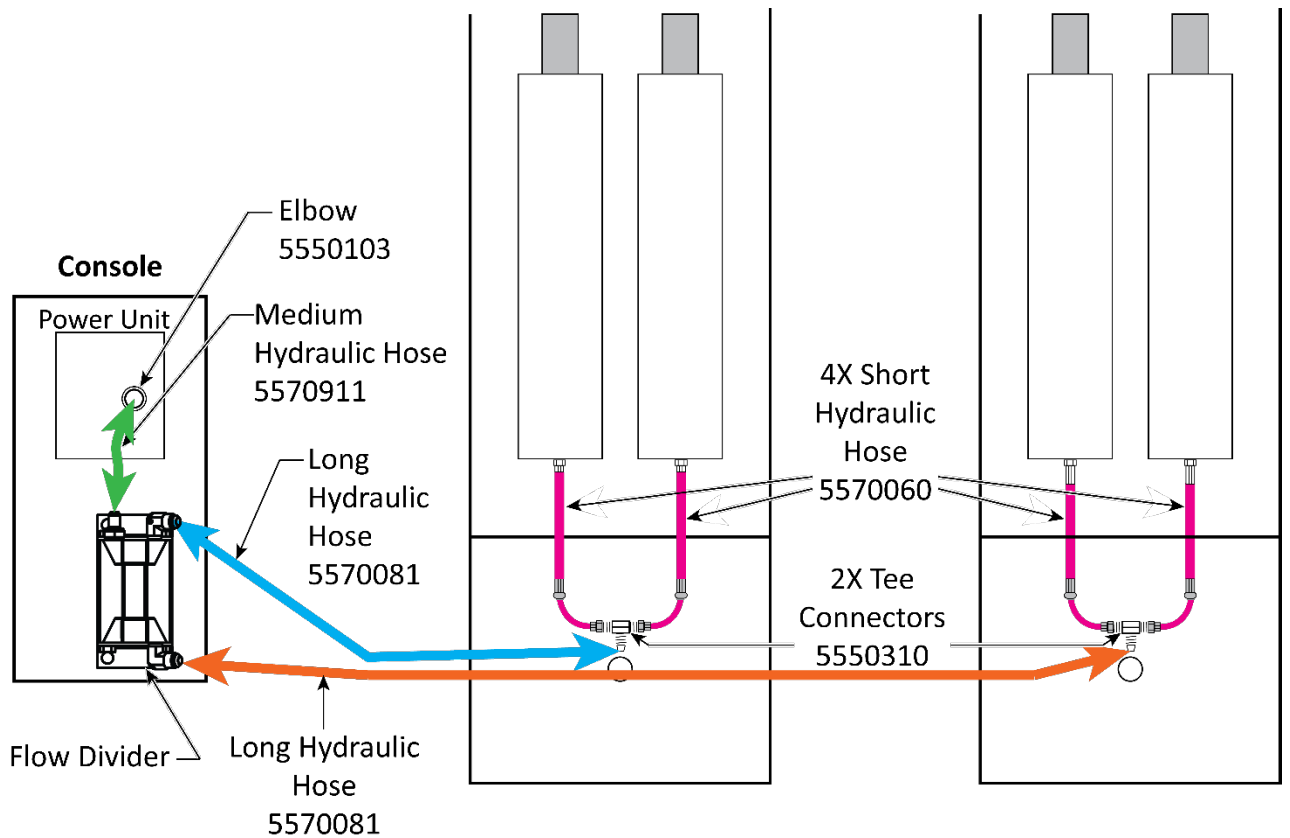

*The Console is on the Left in the drawing. Not to scale. Not all components shown. Some components exaggerated for clarity.*

## To connect the Hydraulic Hoses:

1. If the Platforms are not already engaged on their top Safety Locks, raise them now, using a Shop Crane or Forklift.

Refer to [Lift the Platforms off the Bases](#) for additional information.

2. If the front and top of the Console are in place, remove them.
3. Find a suitable location for the Flow Divider on or near the bottom of the Console. The Flow Divider need **not** be secured to the Console or the floor. See figure to the right.
4. Attach an Elbow Hydraulic Fitting (5550103) to one of the two Hydraulic Power **Out** ports on the Power Unit. Use PTFE Sealant on all fittings with NPT threads. See figure below.

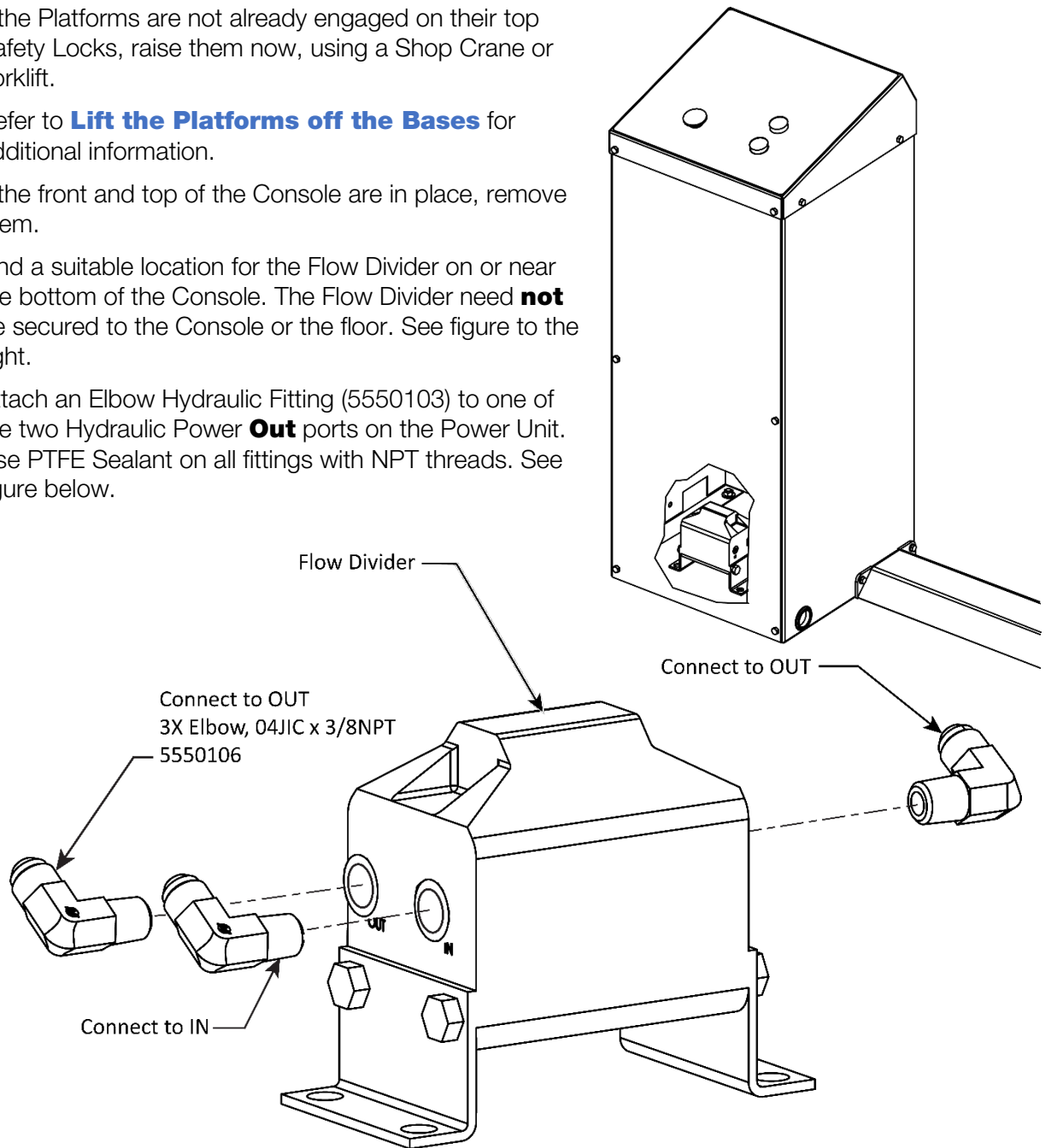

*Not to scale. Not all components shown.*

5. Locate the Medium Hydraulic Hose (18 inches, 458 mm).
6. Connect one end of the Medium Hydraulic Hose to the Elbow Hydraulic Fitting you just installed on the Power Unit and the other end to the **In** connector on the Flow Divider. Hand tighten the connections. No PTFE Thread Sealant is required for the JIC Flared Hydraulic Hose connections.

If you have trouble identifying the Power and Return Ports on the Power Unit refer to the [Connect and Prepare the Power Unit](#) for a diagram showing the port locations.

7. Locate the two Long Hydraulic Hoses.
8. Connect the Long and Extra Long Hydraulic Hoses to the two **Out** connectors on the Flow Divider. It does not matter which line connects to which output connector on the Flow Divider. Hand tighten the connections.

9. On the **MDS-6LP** and **MDS-6EXT** route one Long Hydraulic Hose through rectangular opening in the bottom of the Console and terminate it in a Tee Connector on the Frame Assembly **closest to the Console**. Hand tighten the Tee connection. Coil any excess hose inside the console.

Route the second Long Hydraulic Hose through rectangular opening in the bottom of the Console, through the close frame assembly and terminate it in a JIC Flare Tee in the Frame Assembly **furthest away from the Console**. Make the tee connection hand tight.

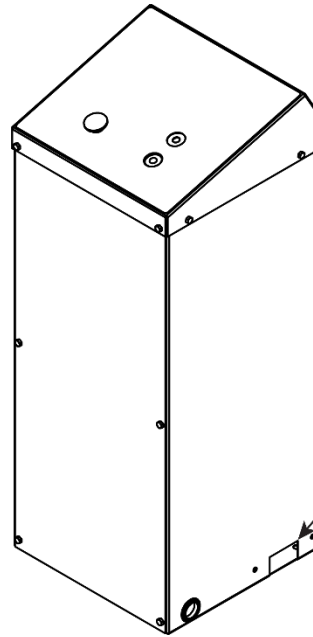

MDS-6EXT and LP, if using the Hose Trough, route Hydraulic Hoses through this opening on the side closest to the Lift.

*Not to scale. Not all components shown.*

10. On the **MDS-6LPF** and **MDS-6EXTF** feed the long Hydraulic Hoses through the conduit in the Concrete to the Frame assemblies. Route the Long Hose with a Tee at the closest Frame Assembly. Feed the second long Hose through the Conduit between the Frame Assemblies. Route the Extra-Long Hydraulic Hose to the Tee at the Frame Assembly furthest from the Console.
11. Remove the shipping plugs from the bottom of all four Hydraulic Cylinders. Have some rags at hand. There may be residual oil in the cylinder.
12. Retrieve the Short Hydraulic Hoses (10 inches / 254 mm) Connect the 3/8 NPT end to the bottom of the Cylinder using the PTFE Thread Sealant.
13. Connect the Elbow end of the Short Hydraulic Hose with the 7/16 JIC Flare to the Tee. Make hand tight.
14. Connect the other three Hydraulic Cylinders and Hoses in the same manner.
15. Once all connections have been made, use appropriate tools to fully tighten all the connections. Be systematic. Start at one end and work your way through without missing any of the Hydraulic Fittings.

---

## Working with Compression Fittings and Tubing

Your Lift comes with ¼ inch, black, polyethylene Tubing (also called Poly-Flo® Tubing) that is used with Compression Fittings to create the Air Lines and Return Line (Cylinder Vent).

**Important:** Compression Fittings are not the same as Hydraulic Fittings. ***This section covers Compression Fittings only.***

The components involved with Compression Fittings include:

- **¼ inch, black, polyethylene Tubing.** The Air Lines and Return Lines require multiple Tubing pieces. Create the Tubing pieces from the long roll of Tubing supplied with your Lift.
- **Elbow Compression Fittings.** The Air Lines use two Elbow Compression Fittings.
- **Straight Compression Fittings.** The Return Lines use four Straight Compression Fittings.
- **Tee Compression Fittings.** The Air Lines use one Tee Compression Fitting; the Return Lines use three Tee Compression Fittings.
- **Nuts, Ferrules, Rods, and Threads.** Many of the connectors on the Elbow, Straight, and Tee Compression Fittings have a Nut, Ferrule, Rod, and Threads (see drawing below). The Nut holds the Tubing and Fitting together. The Ferrule compresses when you tighten the Nut on the Threads to make a secure connection. The Rod goes inside the Tubing so that nothing leaks out.

The following drawing shows the components of a connector on a Tee Compression Fitting.



**Important:** ***Ferrules can only be tightened once.*** When you tighten the Nut on the Threads, the Ferrule should be compressed; and it should change its shape and ***should not*** be used again.

### To connect Tubing to a Compression Fitting:

1. Push the Tubing through the Nut and Ferrule then over the Rod.  
Do not push hard; you only need the Tubing to go a little way over the Rod. You cannot see the Ferrule at this point, but the Tubing must go through the Ferrule and over the Rod.
2. Slide the Nut on the Tubing ***away from the Fitting***; if the Nut is still on the Threads, unscrew it from the Threads and then slide it away from the Fitting. See the drawing above.
3. Slide the Ferrule over the Tubing, away from the Fitting and towards the Nut.
4. With the Nut and the Ferrule out of the way, push the Tubing further over the Rod until it stops.
5. Slide the Ferrule and the Nut back to the Threads on the Fitting.  
The Ferrule goes around the Rod and under the Threads. The Nut goes onto the Threads.
6. Tighten the Nut.

Remember that the Ferrule can only be used once; do not tighten the Nut until everything is ready.



## To connect the Air Lines:

1. Locate one ¼ in. Tee Compression Fitting, and the black ¼ in. Air Tubing.
2. Air lines may be routed together with the Hydraulic Lines. Measure and cut the Tubing into appropriate lengths for your installation. One length from the Console to the first Lift Frame where a Tee branches the air off to the first Lift Frame Air Cylinder and to the second Lift Frame Air Cylinder.



**Tip** BendPak recommends planning out the path of the Air Line **before** you start cutting the Tubing.

3. Feed the Air Line tubing from the Console to the First Lift Frame.
4. Connect a tee to the end of the tubing from the Console.
5. Connect Tubing lengths from the Tee Fitting to the Tubing Fitting coming from the Air Cylinders in both Lift Frames.

To get to the Air Cylinders, the Tubing is routed along the Scissor arms of the Lift. The Scissor arms have tubes through which you route the Poly-Flo Tubing, which protects them as you raise and lower the Lift.

6. Retrieve the Console Top. On the underside of the Console top, attach the male end of a Compression Elbow Fitting (to the **CYL** connector on the Pushbutton Air Valve, then connect the final tubing length to the compression end of the Elbow Compression Fitting. The threads on the valve itself are 1/8-27NPT and require PTFE thread sealant.
7. On the underside of the Console top, attach the male end of a Straight Expander Fitting to the **IN** connector on the underside of the Pushbutton Air Valve. This is an 1/8-27NPT thread that requires PTFE Thread Sealant.
8. Connect the customer-supplied air pressure to the other end of the Straight Fitting this is a Female ¼-18 NPT fitting requiring PTFE Sealant as well.

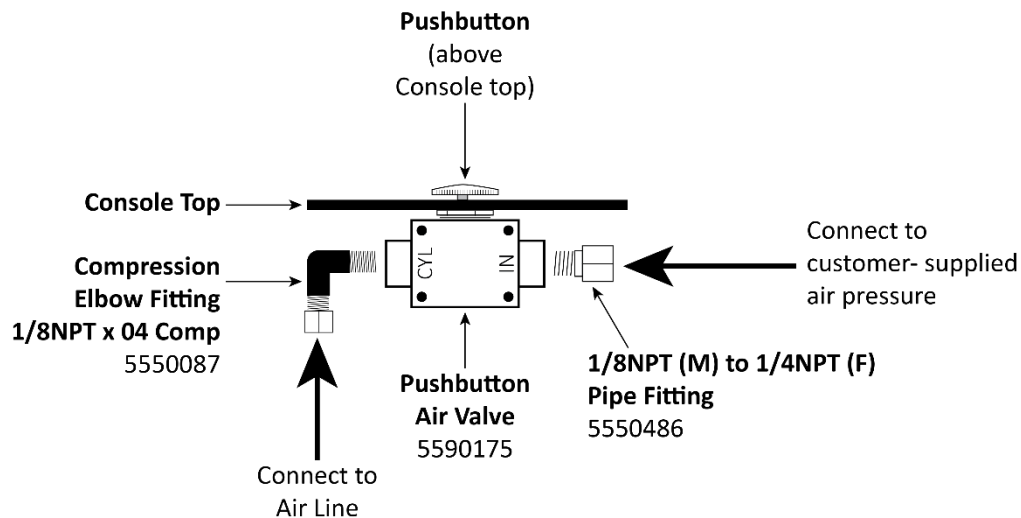

*Pushbutton is above the Console top panel; all other components are under the Console top.  
Drawing not to scale. Not all components shown.*

## Connect the Return Lines

The Return Line returns Hydraulic Fluid from the Hydraulic Cylinders to the Power Unit's Hydraulic Fluid Reservoir.

Create the Return Line using the ¼ inch black plastic Tubing that came with the Lift; you need to cut it into sections of the appropriate length.

**Important:** The Air Line and the Return Line use the same ¼ inch, black, polyethylene Tubing. Be sure not to confuse the two; the Air Line and the Return Line do completely different things and **must** be kept separate from each other. The Return Lines may be marked with tape to positively identify them.

The following drawing shows how the Return Line is routed.

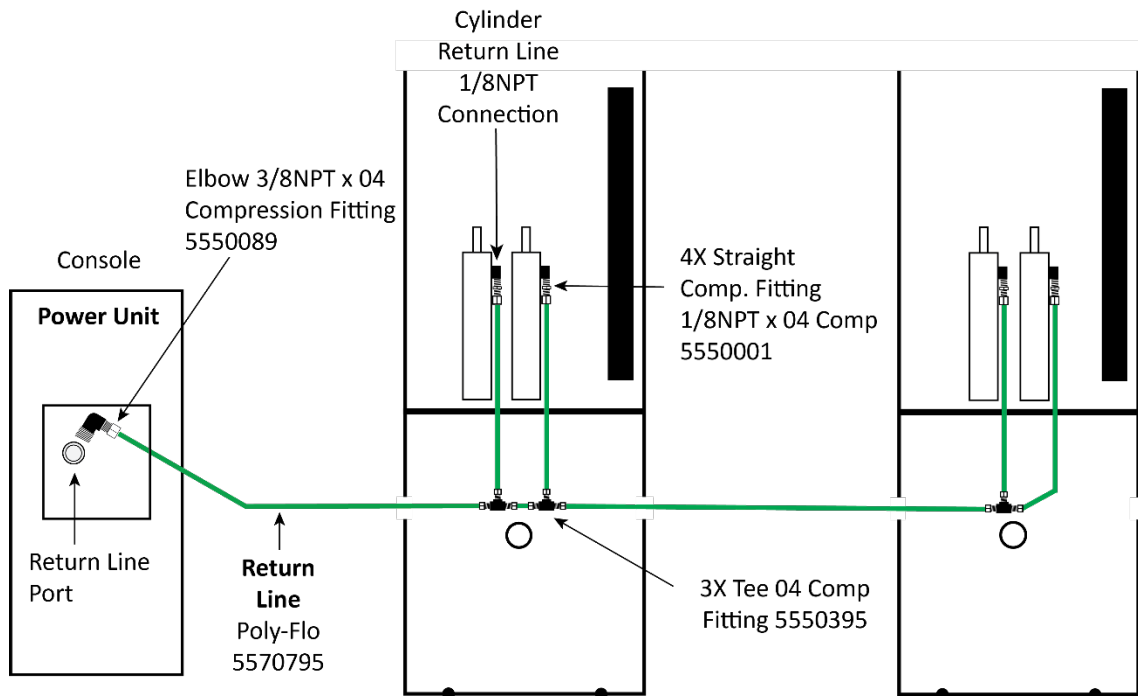

*Top view. Not drawn to scale. Not all components are shown.*

### To connect the Return Line:

1. Locate three Tee Compression Fittings, four Straight Compression Nipples (¼ Comp to 1/8-27NPT), and the black ¼ in. Air Tubing.
2. Remove the plastic shipping plug in the Cylinder Return Ports (Cylinder Vents) on all four cylinders.
3. Use PTFE Sealant on all NPT threads and connect the NPT end of the four Straight Compression Fittings to the Return Ports on the Lift Cylinders in the Left and Right Lift Frames and tighten.

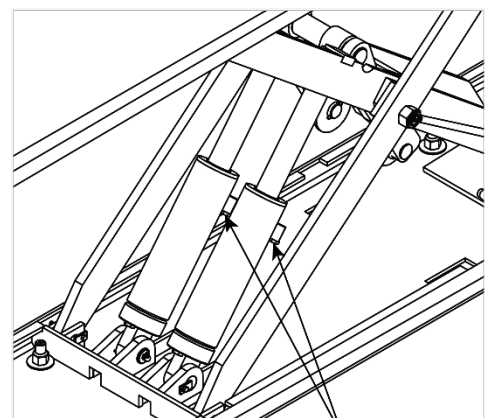

Remove the four plastic shipping plugs from the Cylinder Return Ports

4. Attach an Elbow Compression Fitting with a 3/8 NPTF x 04 Compression to one of the Return Line Ports (Cylinder Vent) on the Power Unit.

There are two Return Line connectors on the Power Unit; they function identically. **You only need to use one, not both.**

See **Connect and Prepare the Power Unit** for the Return Line Port locations.

5. Cut tubing sections of the appropriate lengths for the Return Line segments.
6. Connect the tubing sections using the three Tee Compression Fittings, as shown above.

## Install the Inner Hose Cover (MDS-6EXT and MDS-6LP Only)

The Hose Covers are required to protect the Hydraulic Hoses and the Air Line from damage.

### To install the Inner Hose Cover:

1. Retrieve the Inner and Outer Hose Covers, eight M6 x 25mm Hex Head Bolts and eight M6 Flat Washers from the Parts Box.

The Inner Hose Cover is adjustable to account for the variable distance between the Lifting Platforms. The Outer Cover is not adjustable.

2. Cover the Hydraulic Hose and Air Line between the Frames with the Inner Hose Cover. Adjust the Cover length as shown to the right, then secure with four M6 x 25 Hex Head Bolts and Washers.

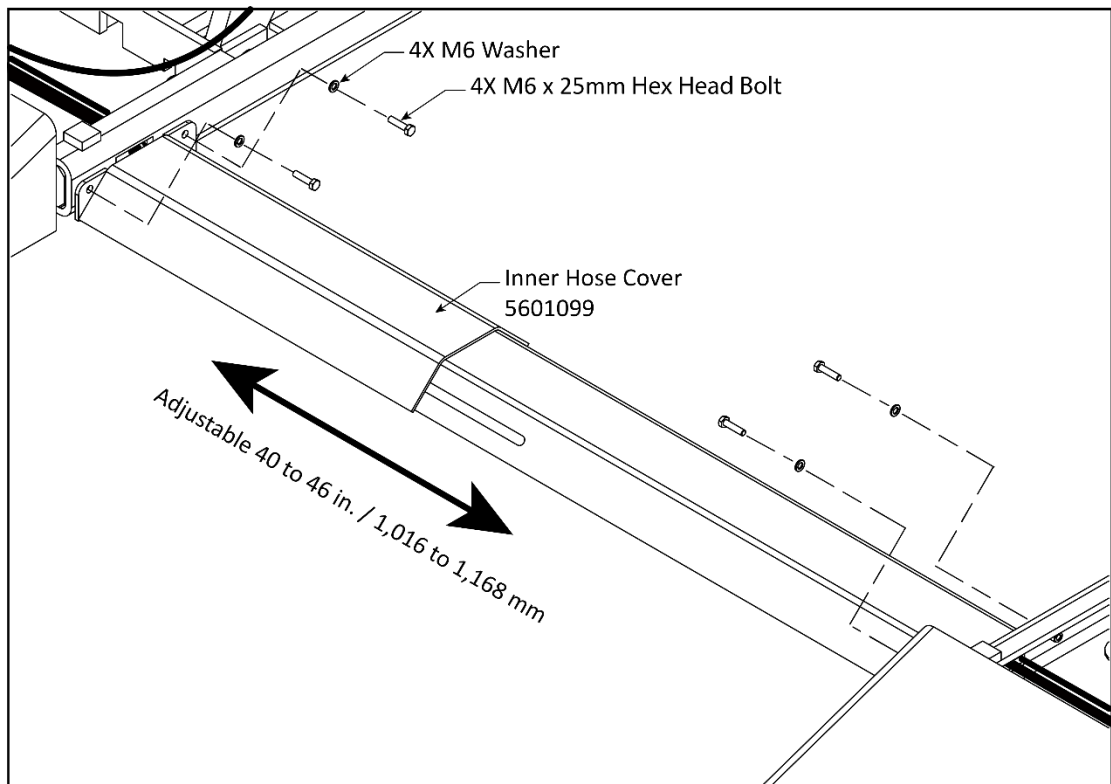

*Not to scale. Not all components shown.*

## Install the Outer Hose Cover (MDS-6EXT and MDS-6LP Only)

The Outer Hose Cover measures 40.25 in. / 1,022 mm long and is not adjustable for length.

### To install the Outer Hose Cover:

1. Retrieve the Outer Hose Cover, four M6 x 25 mm Hex Head Bolts, and four Washers from the Parts Box.
2. Install the Outer Hose Cover between the Console and the Lifting Platform covering the Hydraulic Hoses and Air Line. Any excess hose should be coiled inside the Console.
3. Secure the Cover using the four M6 x 25mm Hex Head Bolts and M6 Washers you retrieved earlier. The Console is shown below mounted on the Left side of the Lifting Platforms, but it may also be mounted on the right side.

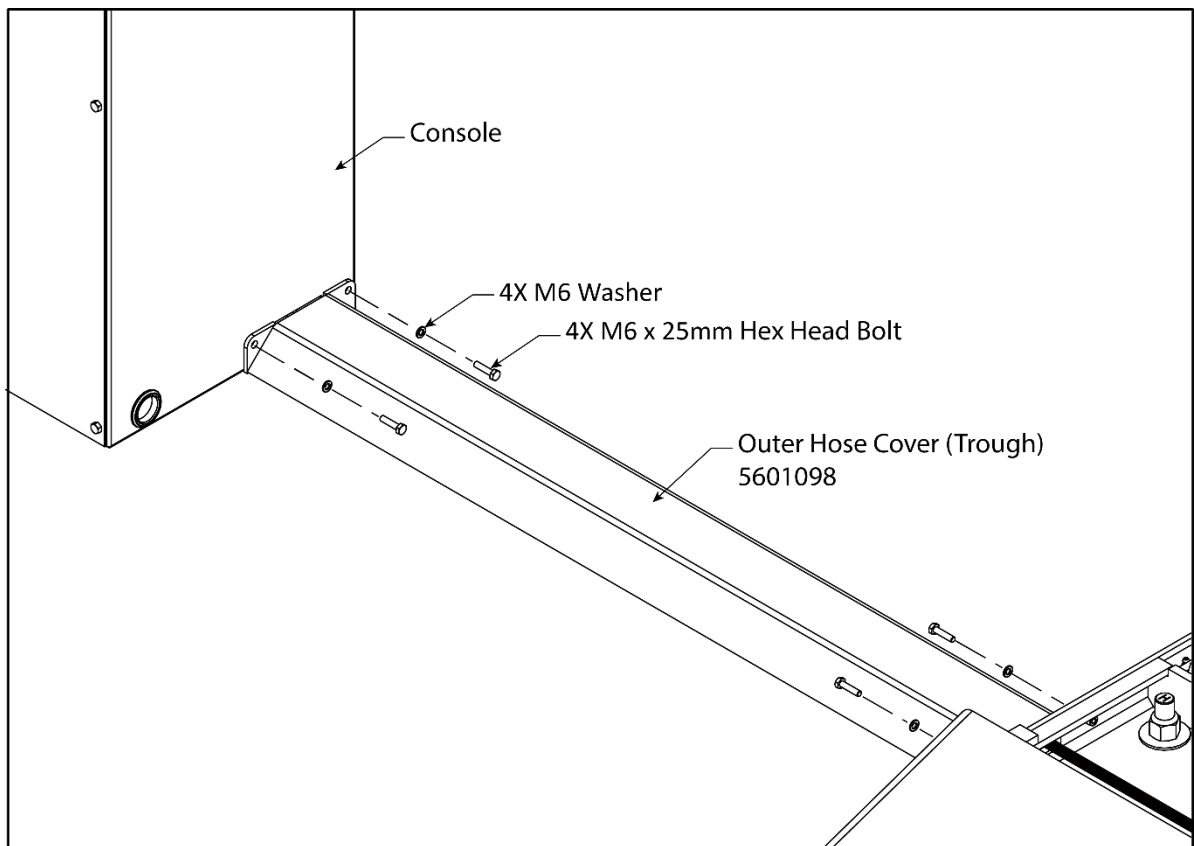

---

## Contact the Electrician

The following tasks require a licensed Electrician.

**⚠ DANGER** All wiring **must** be performed by a licensed Electrician in accordance with all national, state, and local electrical codes. If someone who is not a licensed Electrician attempts these tasks, they could be electrocuted, resulting in severe injury or death.

The Electrician needs to:

- **Attach a Power Cable with an appropriate plug.** The Power Unit needs to connect to an appropriate power source; it comes with a pigtail exiting the Electrical Box, but without a longer power cable or a plug attached. The Electrician needs to *remove* the pigtail and then connect a NEMA rated power cable with a plug that is appropriate for your location (220 VAC plugs are different in different parts of the world). ***This power cable and plug is not provided with the Lift.*** Alternatively, the Electrician may connect the power unit directly into the facilities' electrical system protected by an appropriate Circuit Breaker.
- **Install a Power Disconnect Switch.** Ensures you can quickly and completely interrupt electrical power to the Lift in the event of an electrical circuit fault, emergency, or when equipment is undergoing service or maintenance. You must put it within sight and easy reach of the Lift operator. Refer to **Install a Power Disconnect Switch** for more information.
- **Install a Thermal Disconnect Switch.** Ensures the equipment shuts down in the event of an overload or an overheated motor. Refer to **Install a Thermal Disconnect Switch** for more information. ***The motor on the Power Unit is not thermally protected.***

The Electrician is responsible for providing:

- an appropriate power cable and NEMA rated plug for connecting to the power source, or appropriately connecting into the facility power adhering to all National and Local Electrical Codes.
- a UL-Listed Power Disconnect Switch accessible and within the operator's line of sight.
- a Thermal Disconnect Switch (the Power Unit's motor is **not** thermally protected) conforming to all National and Local Electrical Codes.

Refer to the **Wiring Diagram** or the diagram inside the junction box of the Power Unit Motor for additional wiring information.

Additional information is supplied in the section describing these tasks.

---

## Connect and Prepare the Power Unit

The Power Unit comes assembled from the factory. You need to attach it to the back of the Console (described in [Assemble and Anchor the Console](#)) and then connect it properly.

The standard Power Unit for your Lift is 230 VAC 1Ph. at 50/60 Hz, or 208-230 VAC at 60 Hz, 1 Ph. (other input power variations are available).

**⚠ DANGER** A licensed Electrician must perform all wiring, in accordance with national, state, and local electrical codes. If someone who is not a licensed Electrician attempts these tasks, they could be electrocuted, resulting in severe injury or death.

Refer to [Wiring Diagram](#) for wiring information.

**⚠ CAUTION** The Electrician must select and install an appropriate Power Disconnect and Thermal Disconnect cutoff switch.

The Power Unit has multiple connections:

- **Hydraulic System.** The Medium Hydraulic Hose connects one of the two Hydraulic Power Out ports on the Power Unit to the Flow Divider (and eventually to the Hydraulic Cylinders). Connected earlier.
- **Return Line.** Takes Hydraulic Fluid from the Hydraulic Cylinders and returns it to the Reservoir. Connected earlier.
- **Power Source.** The Power Unit connects to an incoming power source.
- **Controls.** The Power Unit connects to the controls on the top of the Console (the Raise and Lower buttons).

### To connect and prepare the Power Unit:

1. Remove the front cover of the Console if it is currently in place.
2. For the Raise and Lower buttons on the Console, the wiring comes from the factory connected to the appropriate button. Simply connect them mechanically to the Console.
3. For the connection to the Hydraulic System, the Power Unit should already be connected to the **IN** connector on the Flow Divider via the Medium Hydraulic Hose.

**If it is not**, apply a few drops of hydraulic fluid to the O-ring of the Elbow Hydraulic Fitting to a Hydraulic Power Out connector on the Power Unit, connect the Medium Hydraulic Hose to this Elbow Hydraulic Fitting, and then connect the other end of the Medium Hydraulic Hose to the **IN** (input) connector on the Flow Divider.

4. For the Return Line, the Return Line should already be connected to one of the two Return Line Ports on the Power Unit and the tops of the Hydraulic Cylinders on the Lift.

**If it is not**, see [Connect the Return Line](#) for more information.

5. For the power source, the Electrician should locate the Pigtail coming out of the Electrical Box, open the Electrical Box, remove the Pigtail, and then insert the power supply cable into the junction box and make the appropriate connections. The power cord and plug are **not** supplied with the Lift.

Refer to the [Wiring Diagram](#) or the diagram inside the motor's junction box cover for proper wiring information.

**⚠ DANGER**

a licensed Electrician must perform all wiring, in accordance with all national, state, and local electrical codes. If someone who is not a licensed Electrician attempts these tasks, they could be electrocuted, resulting in severe injury or death. Do not perform **any** maintenance or installation on the Lift without first making sure that main electrical power has been disconnected from the Lift and **cannot** be re-energized until all procedures are complete.

**Important Electrical information:**

- Improper electrical installation can damage the Power Unit motor; this damage is not covered under warranty.
- Use a separate circuit breaker for each Power Unit.
- Protect each circuit with an appropriate time-delay fuse or circuit breaker rated for the power unit motor delivered with your Lift.

Refer to the power unit diagram on the following page for Hydraulic Input and Output ports.

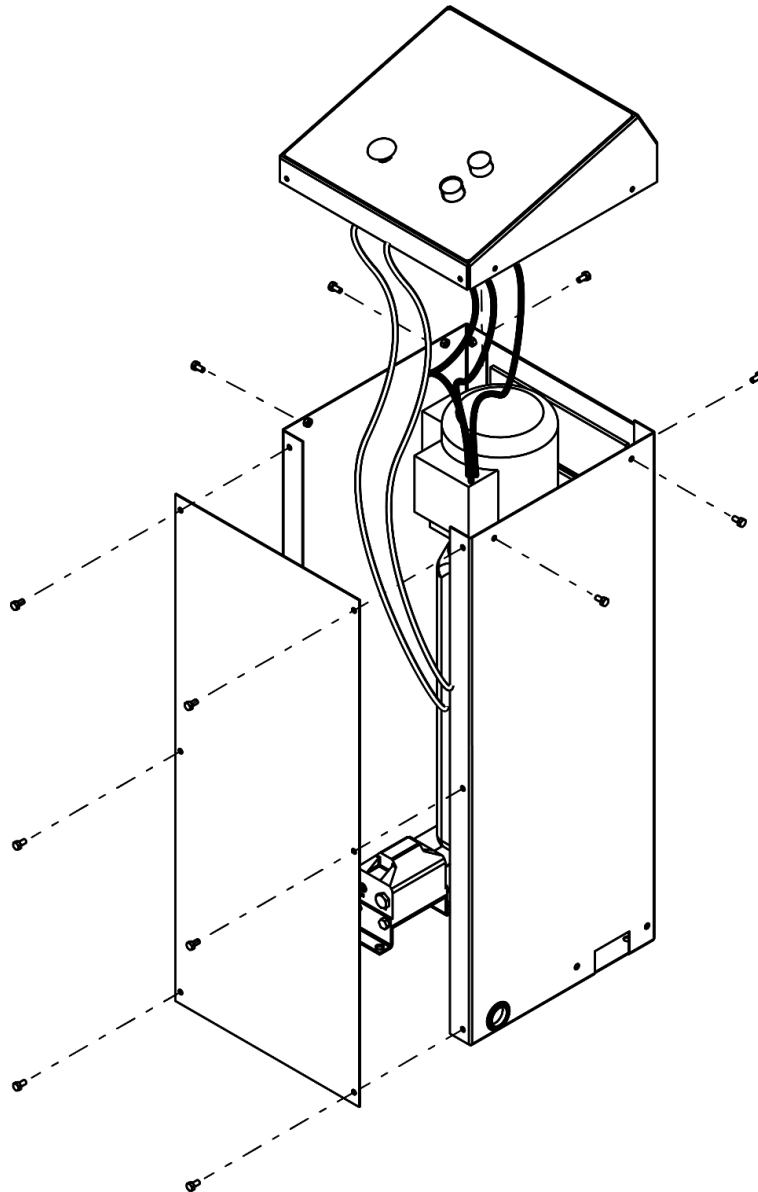

*Drawing not to scale. Not all components shown.*

## Power Units - Power Ports and Return Ports Location

**5585367**

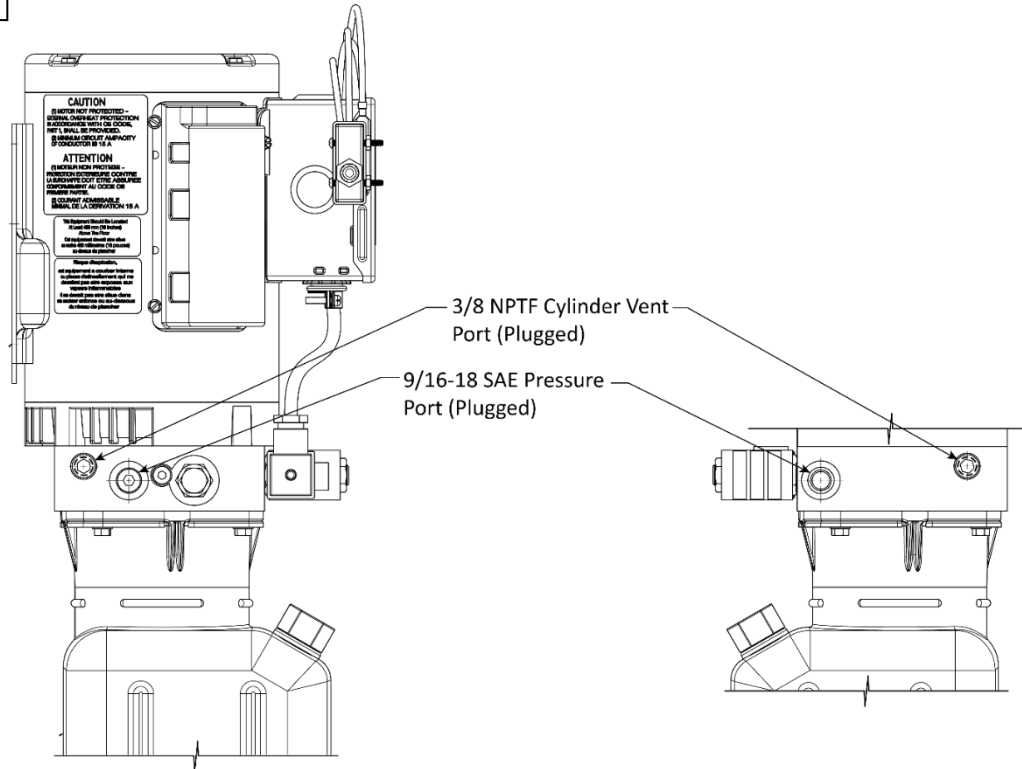

**5585019**

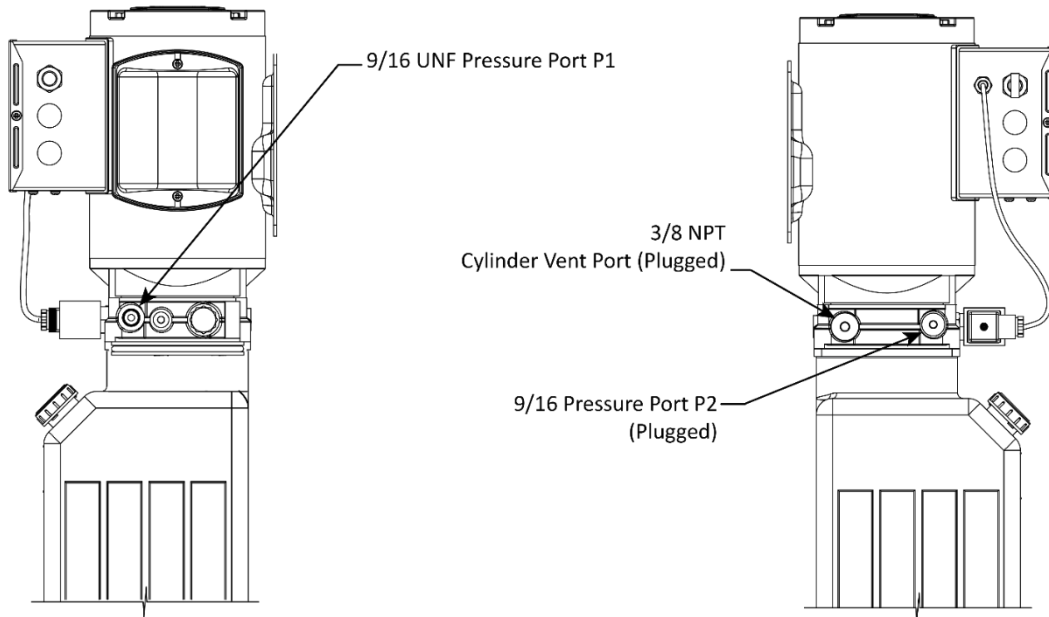

*Drawing not to scale. Not all components shown.*

5585002

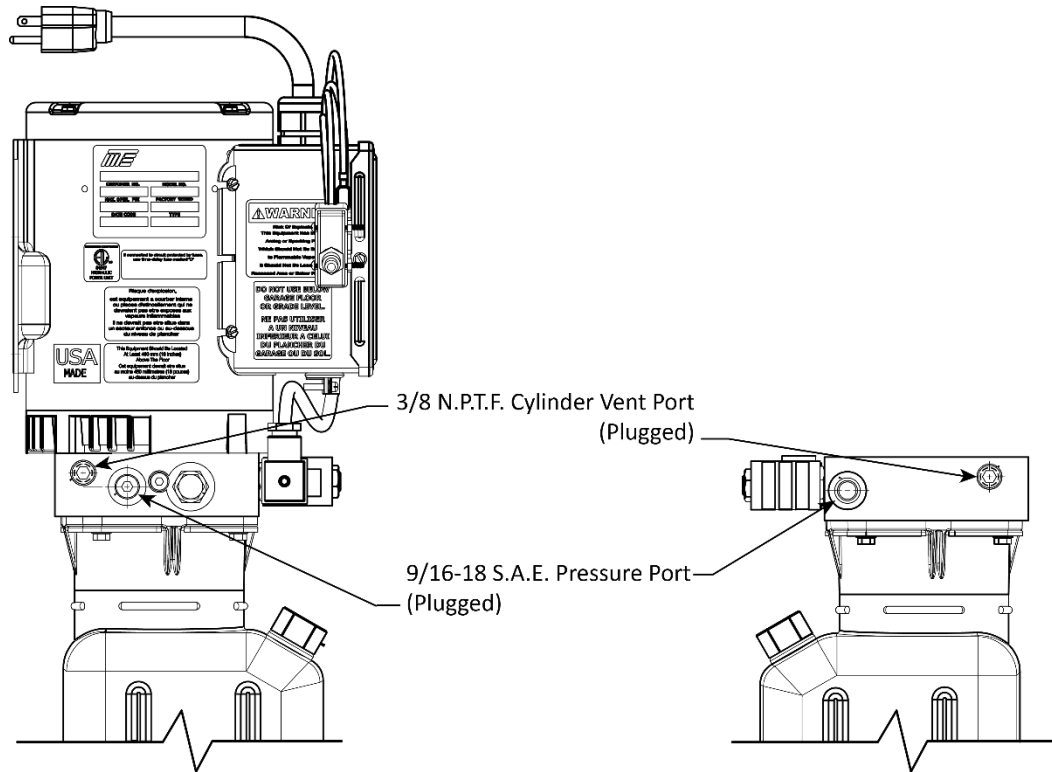

Drawing not to scale. Not all components shown.

## Fill the Hydraulic Fluid Reservoir

The Hydraulic Fluid Reservoir on the Power Unit must be filled with Hydraulic Fluid **before** you begin normal operation of the Lift. **When you receive the Lift, the Hydraulic Fluid Reservoir is empty.**

The Power Unit will not work correctly until the Reservoir is filled with approved Hydraulic Fluid.

Approved fluids are any general-purpose ISO-32, ISO-46, or ISO-68 Hydraulic Fluid, approved automatic transmission fluids such as Dexron III, Dexron VI, Mercon V, Mercon LV, or any synthetic multi-Vehicle automatic transmission fluid.

**⚠ WARNING** Do **not** run your Power Unit without Hydraulic Fluid; you will damage it.

### To fill the Hydraulic Fluid Reservoir:

1. Remove the Reservoir Cap from the top of the Hydraulic Fluid Reservoir and set it aside.  
Take care to **keep contaminants out** of the Hydraulic Fluid Reservoir.
2. If the Hydraulic Fluid Reservoir is not full, fill it with approved fluid.  
The Reservoir holds approximately 1.5 gallons / 6 liters of Hydraulic Fluid.
3. When the Reservoir is filled, put the Reservoir Cap back on.

**Important:** Typically, the Platforms are up on the first Safety Lock at this point. Be aware that you will need re-fill the Reservoir during the **Operational Test**. The Cylinders and Hydraulic Hoses will take up a considerable amount of fluid. If you have installed longer hoses, then more than the specified 1.5 gallons will be required.

---

## Install a Power Disconnect Switch

**⚠ WARNING** A Power Disconnect Switch is **not** provided with this equipment.

A Power Disconnect Switch is a National Electrical Code (NEC) requirement. They are designed to interrupt main electrical power in the event of an electrical circuit fault, emergency, or when equipment is undergoing service/maintenance.

Make sure to install a **UL-listed** Power Disconnect Switch that is properly rated for the incoming power source.

Your Power Disconnect Switch must be readily accessible and installed so that it is in easy reach of the operator or in their line of sight. The Power Disconnect Switch must be clearly marked to indicate its purpose.

**⚠ DANGER** Installing a Power Disconnect Switch **must** be accomplished by a licensed Electrician in conformance with all National and Local Electrical Codes. Do not perform **any** maintenance or installation on the Lift without first verifying that main electrical power has been disconnected from the Lift and **cannot** be re-energized until all procedures are complete.

The figure below details one suggested location for the power disconnect.

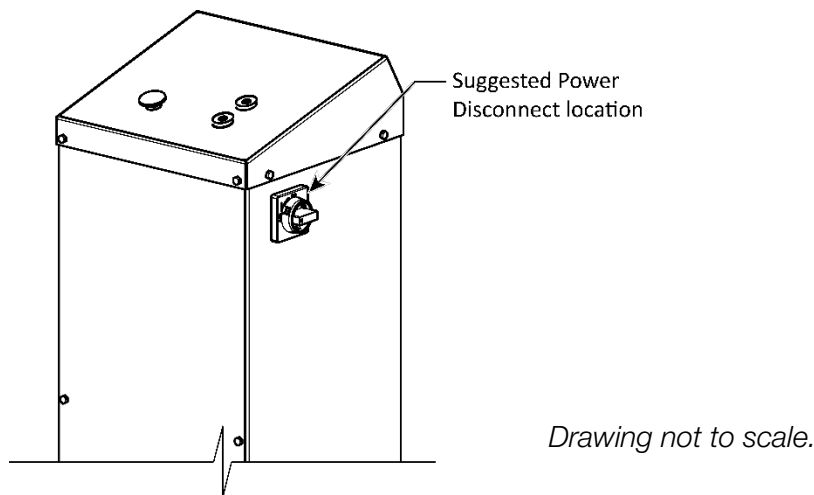

## Install a Thermal Disconnect Switch

**⚠ WARNING** The motor on the Power Unit supplied with your Lift has no thermal overload protection.

Have the Electrician connect an appropriate Thermal Disconnect Switch or overload device that will shut down the equipment in the event of an overload or an overheated motor.

**⚠ DANGER** Installing a Thermal Disconnect Switch **must** be performed by a licensed Electrician in conformance with all National and Local Electrical Codes. Do not perform **any** maintenance or installation on the Lift without first verifying that electrical power has been disconnected from the Lift and **cannot** be re-energized until all procedures are complete.

## Lubricate the Lift

There are 4 Lubrication areas on **each** Lift Frame:

- **Two Lubrication areas along the Base Weldment** where the Slide Blocks travel only.
- **Two Lubrication areas under the Platform** where the Slide Blocks travel only.

Use a small amount of White Lithium Grease or similar on each Lubrication Area before you use the Lift and monthly after putting the Lift into service. Refer to the figures below for the Lubrication areas.

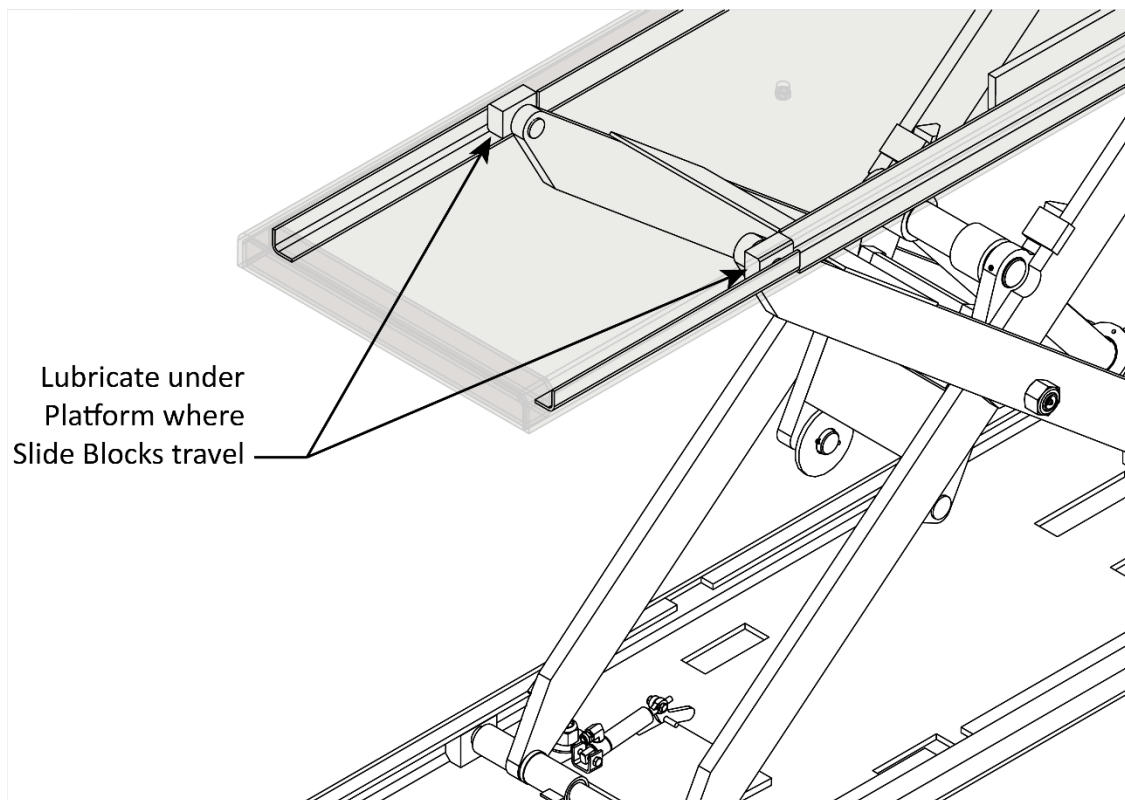
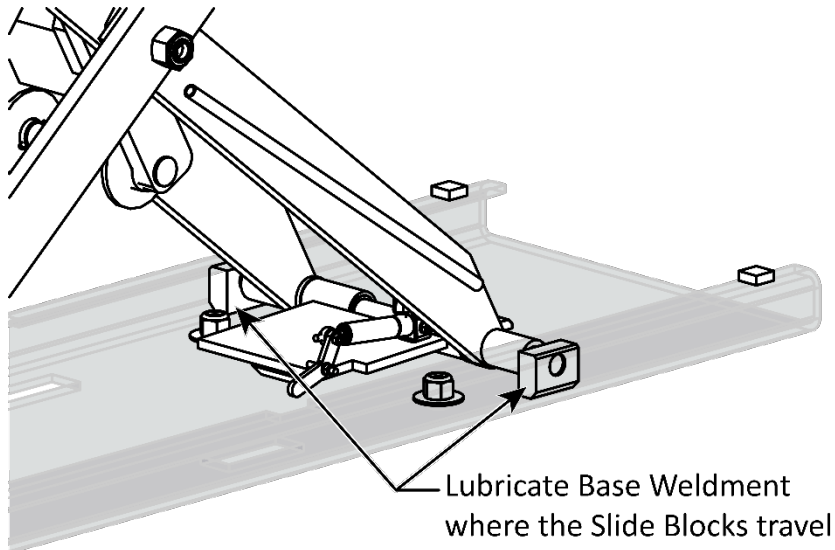

*Drawing not to scale. Not all components shown.*

## Add the Drive-Up Ramps (MDS-6LP and MDS-6XLT Only)

The MDS-6EXT and MDS-6LP include four Drive-up Ramps: two are installed on the front of the Lift and two on the rear. The flush-mount versions of the MDS-6 do not include Ramps. All four Ramps attach by simply dropping onto a Bolt-Washer-Spacer assembly as shown below. The Ramps are designed to be easily removed and float on the bolt assembly at the front and rear of each Base Assembly.

### To Install the Drive-Up Ramps:

1. Retrieve from the Parts Box - four Ramp Extensions, Four Ramps, eight M12 x 30 Hex Head Bolts, sixteen M12 Flat Washers, and eight M12 Nyloc Hex Nuts.
2. Bolt the four Ramp Extensions to the four Ramps using the M12 x 30 Hex Head Bolts, M12 Flat Washers, and Nyloc Nuts.
3. Retrieve eight M12 x 50 mm Hex Head Bolts, eight M12 x Ø37 mm Washers, eight Ramp Spacers and eight M12 Hex Nuts.
4. Secure the Hex Head Bolts, Washers and Spacers to the Front and Rear of each Base Assembly using the Hex Nuts as shown below.
5. Place the Drive-Up Ramp Weldments over each bolt assembly as shown below.

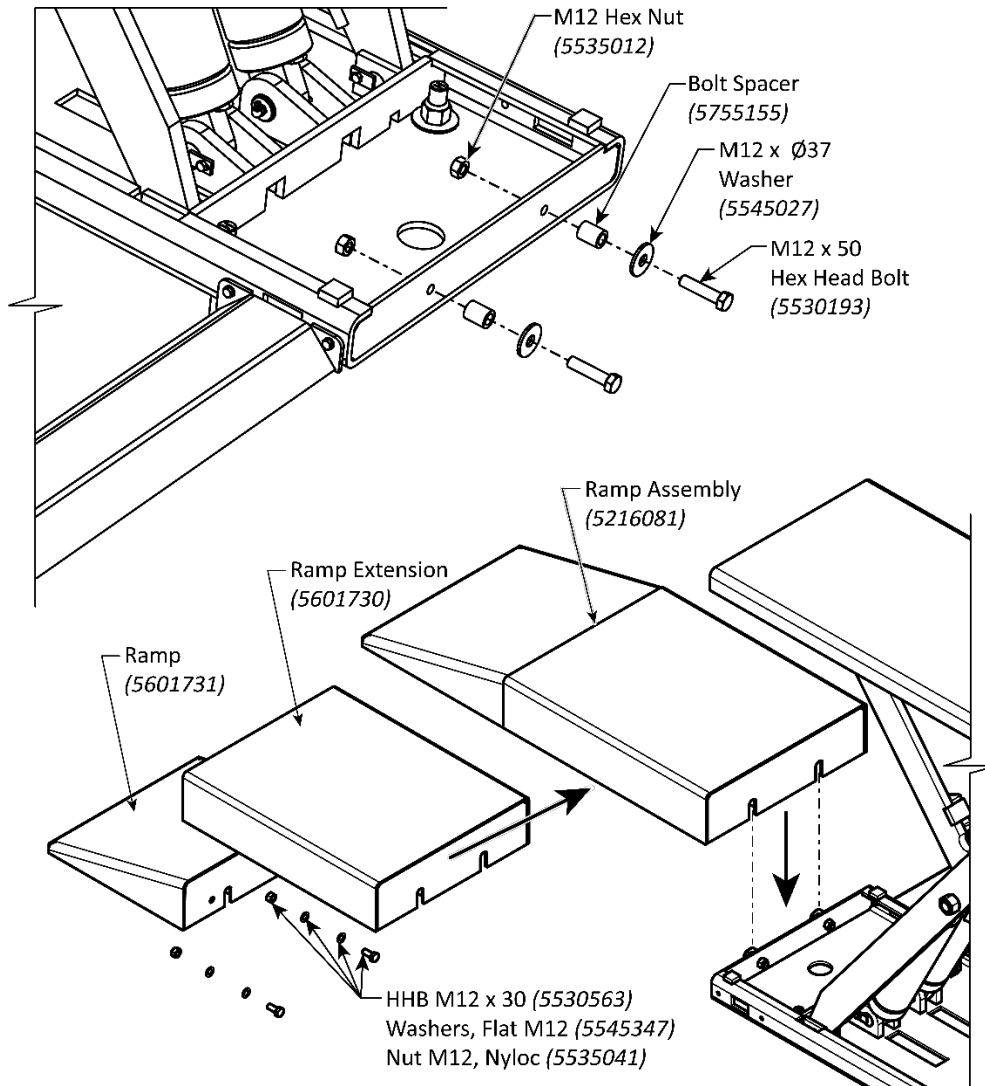

*Drawing not to scale. Not all components shown.*

---

## Anchor the Console

If you have not yet anchored the Console, you must do so now.

Refer to **Assemble and Anchor the Console** for instructions.

Install the Console Cover and secure with the eight M6 Hex Head Bolts.

## Perform an Operational Test

 **WARNING** Before applying power to the Hydraulic system, **always** double check all Hydraulic connections are tight, including fittings, hoses, and auxiliary port plugs.

 **WARNING** Never replace any factory-supplied part with aftermarket or non-OEM part.

Before putting your Lift into normal operation, you need to raise and lower it a few times. This will help provide a feel for how to operate the system, ensures it is working correctly, and helps get any residual air out of the Hydraulic System. The Hydraulic System is self-bleeding.

**Important:** The installation of the Lift is not complete until the Lift passes an Operational Test.



### Tip

Residual air in the Hydraulic System can cause the Lift to shake, move erratically, or squeak; this is normal. If this occurs, do not worry; it will go away quickly as the Hydraulic System purges the air in a self-bleeding process.

A Vehicle on the Lift is not required for the Operational Test, but it is recommended.

### To perform an operational test of your Lift:

1. Check the area around and above the Lift for obstructions; move them if you find any.
2. Press and hold **Raise**. The Platforms start rising.
3. When the Platforms go past a Safety Lock (you can hear the mechanism click as it passes), release **Raise**. The Platforms stop rising.
4. Press and hold **Lower**. The Platforms lower onto the Safety Lock you just passed.
5. Look for Hydraulic Fluid leaks. Repair any leaks and clean Hydraulic Fluid off the floor and surfaces.
6. Check the Hydraulic Fluid Reservoir. The level should be low as the cylinders and hoses have been filled during this initial run. Remove the cap and fill the reservoir, but do **not** top off the reservoir. Fill to about ½ full.

 **WARNING** If you over-fill the Reservoir while the Platform is raised on a Safety Lock, excess fluid will overflow the Reservoir when you return the Lift to the ground.

If you over-fill the Reservoir while the Platform is raised on a Safety Lock, excess fluid will overflow the Reservoir when you return the Lift to the ground.

7. Replace the reservoir cap after filling to  $\approx 1/2$  full.
8. Press Raise for a few seconds to raise the Platform off the safety lock a small amount.
9. To fully lower the Platforms, press and hold the **Safety Lock Release Button** (to disengage the Safety Lock), then press and hold **Lower**. The Platforms will begin to lower.
10. When the Platforms get to the ground, hold **Lower** for a couple of more seconds to make sure both Platforms are fully lowered, then release **Lower**.

---

11. Wait for one minute.

 **WARNING** The Power Unit cannot be run continuously. The motor is not rated for continuous duty.

12. Check the Hydraulic Fluid Reservoir to verify that it is full. Add Hydraulic Fluid as required.

13. Repeat the process, this time raising the Lift higher and then lowering it.

14. If the Lift is working without shaking, moving erratically, or squeaking, it is ready for operation.

If the Lift is shaking, moving erratically, or squeaking, repeat the procedure. It may take a few up and down cycles to completely purge the air from the system.

If you continue to have issues, refer to the **Troubleshooting** section for assistance.

## Final Checklist before Operation

Make sure these things have been done before using your Lift:

- 1. Review the **Installation Checklist** to verify all steps have been performed.
- 2. Verify the Power Unit is receiving power from the power source.
- 3. Check the Power Unit's Hydraulic Fluid Reservoir; it must be full of approved Hydraulic Fluid.

 **WARNING** ***You can damage the motor by running it without enough fluid.***

- 4. Check the Hydraulic System for leaks
- 5. Verify all Hydraulic, Auxiliary Port Plugs on the Power Unit, the Flow Divider and Cylinders are tight.
- 6. Verify all Anchor Bolts are correctly torqued.

## Leave the Manual with the Owner/Operator

Make sure to leave the *Installation and Operation Manual* with the owner/operator so that it is available for anyone who is going to use the Lift.

---

# Operation

This section describes how to operate your Lift.

 **WARNING** Always use care when you are around the Lift. When it is in a lowered position, be careful not to trip over it. When it is raised, be careful not to collide with a Ramp or a Platform. **When the Lift is moving, keep all people, animals, and objects at least 30 feet away.**

 **CAUTION** **Never** work or move under a vehicle on the Lift unless the vehicle is stable, secure, and the Lift is resting on a Safety Lock.

## Lift Operation Safety

Before you raise or lower a Vehicle using your Lift, do the following:

- **Check the Lift.** Check the Lift for any missing, heavily worn, or damaged parts. Do not operate the Lift if you find any issues; instead, take it out of service, then contact your dealer, email [support@bendpak.com](mailto:support@bendpak.com), visit [bendpak.com/support](http://bendpak.com/support), or call **(800) 253-2363**, extension 196.
- **Check the area.** Check the area around the Lift for obstructions; anything that might block the Lift. Do not forget to check **above** the Lift. If you find an obstruction, move it out of the way. Do not allow people or animals within 30 feet of the Lift while it is in motion.
- **Check the operators.** Make sure everyone who is going to operate the Lift has been trained in its use, has read the labels on the unit, and has read the manual. Only the operator at the Console should be within 30 feet of the Lift when it is in motion.
- **Check for safety.** Make sure everyone who is going to be walking near the Lift is aware of its presence and takes appropriate safety measures. Only put Vehicles on the platform. **When raising the Lift, do not leave it until it is positioned on a Safety Lock.** When lowering the Lift, do not leave it until it is fully lowered. Do not allow children to operate the Lift. Do not allow anyone under the influence of drugs, alcohol, or medication to operate the Lift.
- **Check the Vehicle.** Never exceed the Lift's weight rating. Do not allow people inside a Vehicle you are going to raise. Make sure the Vehicle is not overbalanced on either end. Make sure you know and use the manufacturer's recommended lifting points for the Vehicle. Never raise just one side, one corner, or one end of a Vehicle.

## About Lifting Points and Lift Blocks

The raised Vehicle must be balanced on Lifting Blocks that ride on the Lift Platform.

 **WARNING** You **must** use all four Lift Blocks when raising a Vehicle. Never use just one, two, or three Lift Blocks to raise a Vehicle. The Vehicle may become unstable and could slip off the Lift, possibly damaging the Lift, damaging the Vehicle, and injuring anyone under it.

 **WARNING** **You must use the manufacturer's recommended Lifting Points.** Do not 'eyeball' the best location for the Adapters. The Vehicle could become unstable and fall, which could damage the Vehicle, the Lift, and severely injure anyone under it.

**⚠ WARNING** Many specialty or modified Vehicles with unusually short / long wheelbases cannot be raised on a Frame Engaging Lift. Contact the Vehicle's manufacturer for raising or jacking guidance.

To balance a Vehicle on a mid-rise frame-engaging Lift, the Lift Blocks must contact the Vehicle on the manufacturer's recommended Lifting Points. When you raise a Vehicle by its Lifting Points, the Vehicle is balanced.

**NOTICE** The manufacturer's recommended Lifting Points do not take into consideration any major changes that might have been made to the Vehicle. If the engine is removed, or there is a 5,000-pound weight in the trunk, the Vehicle's Lifting Points will not be the best balancing points.

Some vehicles may have the manufacturers' recommended Service Garage Lift Point locations identified by a triangle mark on the underside of the vehicle, reference SAE J2184- (Current Edition). On some vehicles, specific Lifting Points are indicated by a label located on the driver's side door jamb. Your best approach is to find the Vehicle in the *Vehicle Lifting Points for Frame Engaging Lifts* guide, **available through ALI** (pg. 97) or contact the manufacturer of the Vehicle. This guide includes a page of safe lifting suggestions, which everyone who uses the Lift should read. The *Lifting it Right: A Safety Manual from the Automotive Lift Institute* is also **available through ALI** (pg. 97) and includes a wide variety of information about Lifts and how to use them safely.

**Typical Lifting Points:**

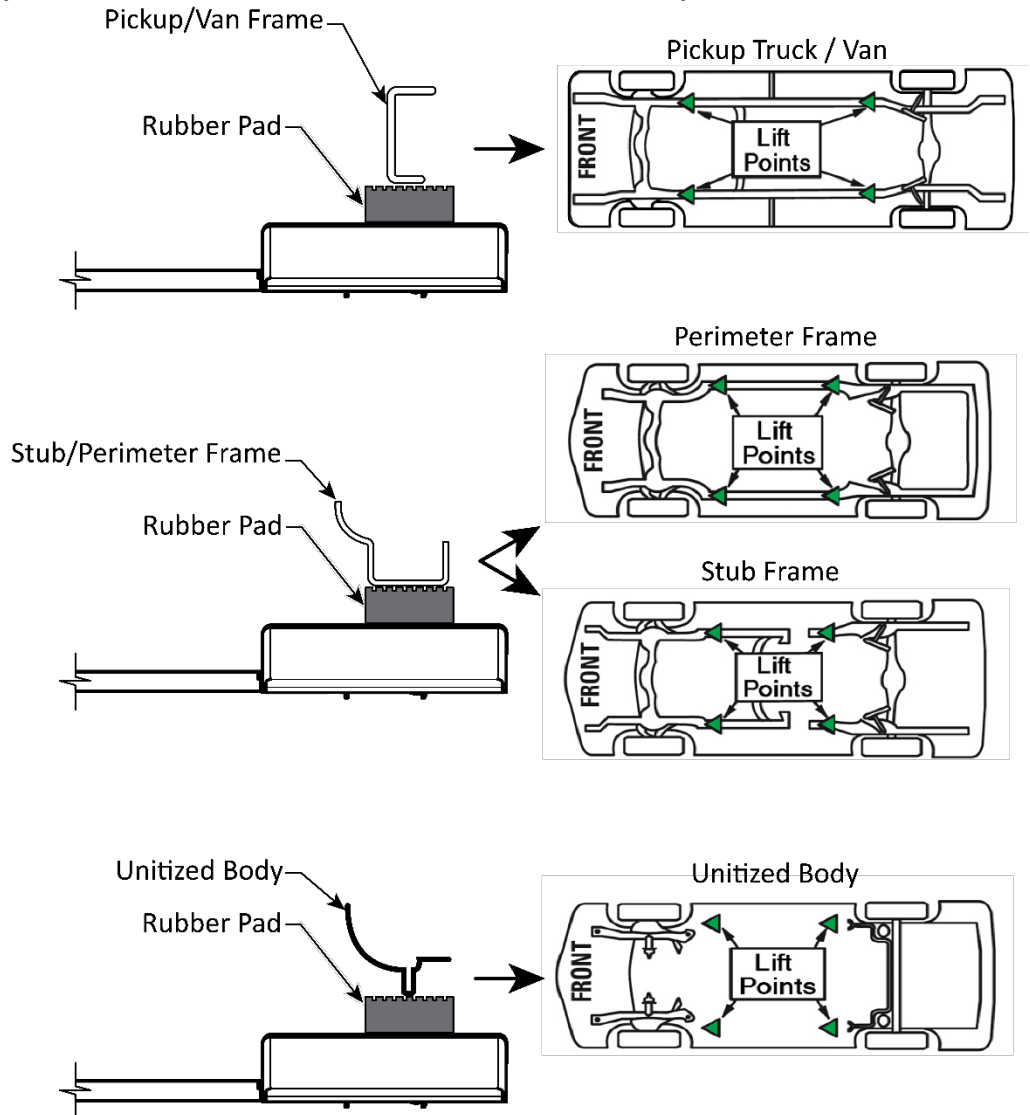

## The Console

Operation of the Lift is controlled via the Console.

The controls on the Console are:

- **Raise** button.  
Raises the Platforms.
- **Lower** button.  
Lowers the Platforms.
- **Safety Lock Release** button. Releases the Safety Locks so the Platforms can be lowered. If you do not press the Safety Lock Release button when pressing the Lower button, the Lift will stop at the closest Safety Lock.



## Raising a Vehicle

This section describes how to position a Vehicle on the Platforms and raise it.

Before raising any vehicle, read, understand, and follow the instructions and warnings in this manual and on the Lift labelling.

- **Never** exceed the rated capacity of this Lift, 6,000 lbs. / 2,722 kg
- **Never** exceed the Maximum load of 3,000 lbs. / 1,361 kg. per Lift side.
- **Always** center the load evenly.
- **Do not** operate the Lift if any component is found to be defective or worn.
- **Never** operate the Lift with any person or equipment under the Lift.
- **Always** ensure the Vehicle is centered and stable prior to operating the Lift controls.
- **Always** verify the Safety Locks are engaged before working on or near any Vehicle.
- **Never** leave the Lift in an elevated position unless the **Safety Locks** on **both** platforms are engaged.
- **Never** attempt to work on, near, or under a vehicle when it is raised on the scissors unless the Safety Locks are engaged.
- Do **not** permit the Power Unit to get wet. The motor can be damaged and water damage is not covered under the product warranty.

**⚠ WARNING** Always allow a minimum of 5-seconds delay between motor starts. Failure to comply may cause switch and/or Motor burnout. This could cause serious damage to the equipment and/or personal property. High electrical running current that exceeds the motor's full load amperage (FLA) rating may result in permanent damage to the motor. BendPak strongly recommends you **not** exceed the rated duty cycle of the motor.

## To raise a Vehicle:

1. Check the items listed in **Lift Operation Safety**.

If you find any issues, resolve them before raising the Vehicle.

2. Make sure both Platforms are fully lowered.
3. Drive the Vehicle onto and completely over the Platforms, positioning the Vehicle's Center of Gravity roughly over the center of the Platforms.

**⚠ CAUTION** When driving a Vehicle onto or off the Platforms, try to keep the wheels in the middle of the Platforms.

4. Put the Vehicle in park, put on the parking brake, and turn off the engine.

If the Vehicle is a manual transmission, put it into first gear before turning it off and setting the brake. You do not want the Vehicle moving while it is raised on the Lift.

5. Get out of the Vehicle and verify the wheels are off the Platforms and place appropriately sized Lift Pads directly under the lifting points for your Vehicle with at least one inch of open space between the Vehicle and the Lift Pad.

### **Only raise a Vehicle if the Platforms are positioned under the lifting points.**

If any part of the Vehicle's lifting points are not completely over the Platform, carefully drive the Vehicle back off the Lift and then drive it back on to reposition it, making sure to keep the wheels in the middle of the Platforms.

**⚠ WARNING** You must use the Vehicle manufacturer's recommended Lifting Points. If you fail to do so, the Vehicle may become unstable and fall off the Pads and/or the Lift which could damage the Vehicle, the Lift or injure or kill anyone near or under the Vehicle.

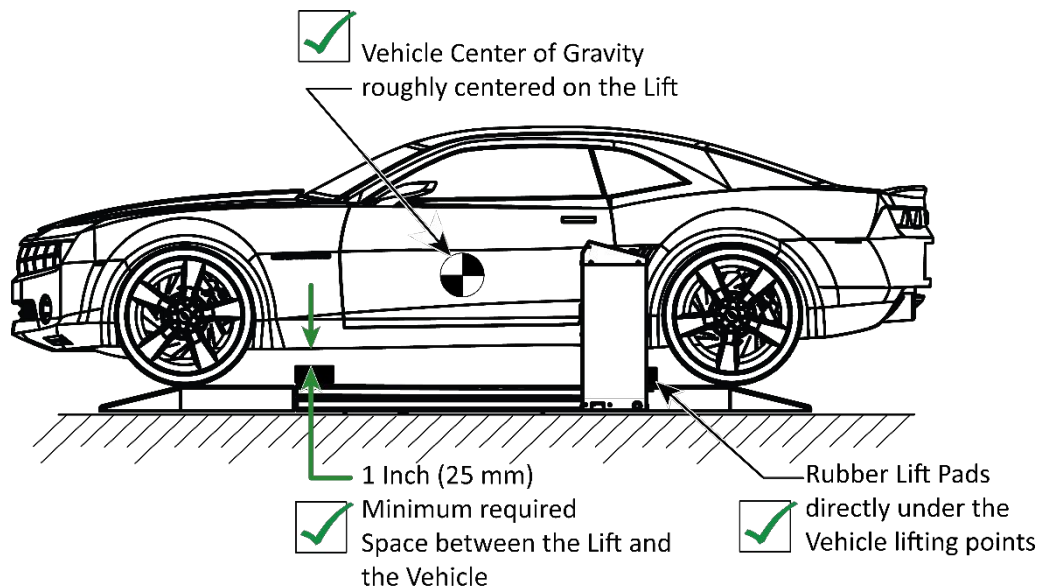

*Drawing not to scale. Not all components shown.*

**⚠ WARNING** **Before** raising a Vehicle, verify there is at least 1 inch (25.4 mm) of clearance between the Lift Pads and the Vehicle. The Lift cannot raise a full load from a completely flat starting position and attempting to lift in this manner will damage the Lift and could injure people nearby.

**⚠ WARNING** **NEVER** lower a vehicle all the way to the floor with the wheels removed. **Failure to comply with these instructions will void the product warranty.** The manufacturer will assume no liability for loss or damage of any kind, expressed or implied resulting from improper installation or use of this product.

Refer to the **Troubleshooting Section** for further information.

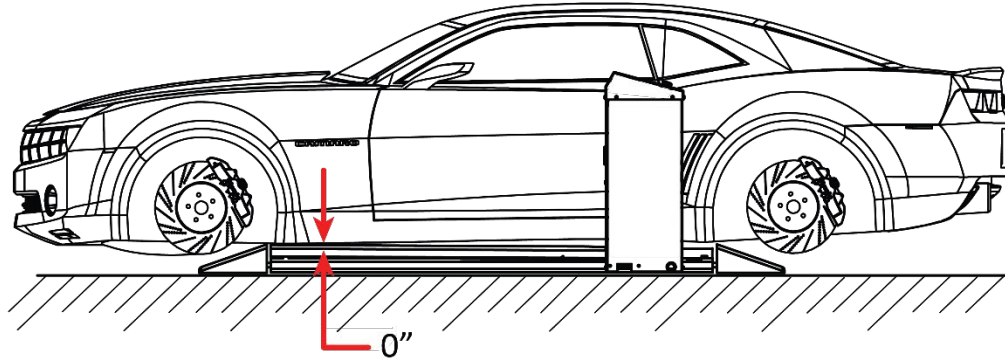

**⊘ No Clearance, No Lift ⊘**

*Drawing not to scale. Not all components shown.*

6. Walk completely around the Vehicle and make sure there are no obstructions or any other issues that will interfere with the raising of the Lift and the Vehicle. Pay careful attention to overhead clearances. If there are any obstructions, remove them before raising the Vehicle.

**⚠ WARNING** **Never** lift a Vehicle with the center of gravity shifted off the Lift Platforms.

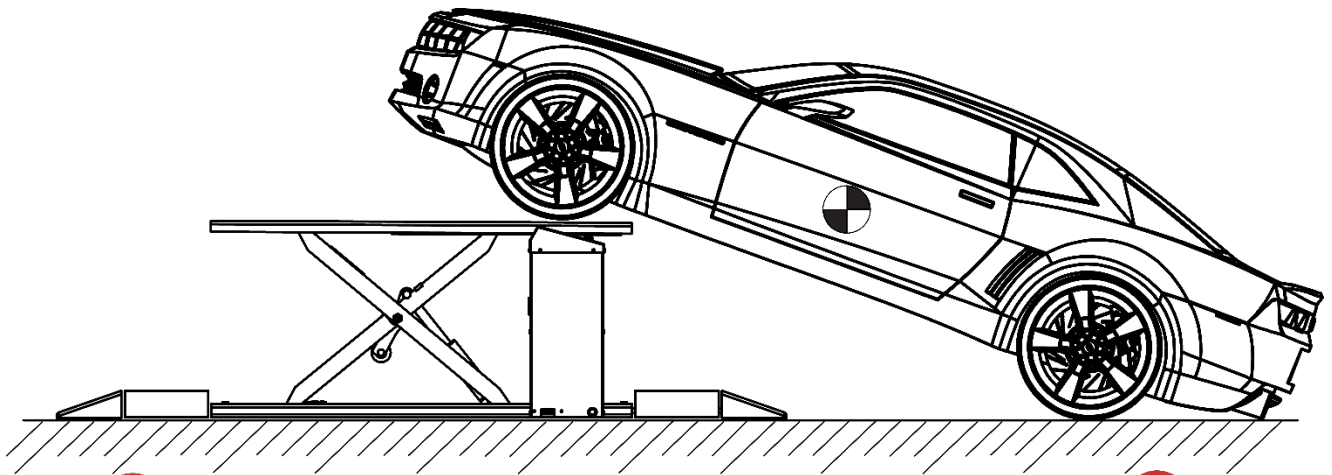



**⊘ NEVER** lift a Vehicle with the Center of Gravity shifted off the Lift Platforms. **⊘**

*Drawing not to scale. Not all components shown.*

7. At the Console, press and hold the **Raise** button until the Rubber Pads come into contact with the Vehicle's lifting points. Release the **Raise** button and walk around the Vehicle again to verify the lifting points are securely engaged on the Rubber Pads. Verify the Vehicle is stable and balanced on the Lift Pads.

---

 **DANGER** Do not raise the Lift further until you are certain the Vehicle on the Lift is both stable and balanced. If the Vehicle is not stable and balanced, it could fall, which could damage the Vehicle, damage the Lift, or injure or kill anyone under the Vehicle.

 **WARNING** Always allow a minimum of 5-seconds delay between motor starts. Failure to comply may cause switch and/or Motor burnout. This could cause serious damage to the equipment and/or personal property.

8. If the Vehicle is secure, press the **Raise** button. Watch the Vehicle and the Lift as they rise.  
If the Lift becomes unstable or the Vehicle begins moving, release the **Raise** button immediately and carefully lower the Lift back down to the ground.
9. When the Platforms are slightly past the desired height, release the **Raise** button.
10. Press the **Lower** button briefly to move the Lift down onto the most recently passed Safety Lock.  
**Always ensure all Safety Locks are engaged** before entering the work area.



**Tip**

If you move the Lift too far past a Safety Lock, it will not engage when you press **Lower** briefly. If this happens, move the Lift back up again, going a little less past the Safety Lock, and then lower it back down onto the Safety Lock.

 **DANGER** Do **not** go under the Vehicle until you have confirmed that both the Lift Platforms are resting on a Safety Lock at the same height.

## About Safety Locks

Each of the Frame Assemblies on your Lift includes its own Safety Lock mechanism. Safety Locks hold a raised Vehicle in place once they are engaged.

Safety Locks serve two important functions:

- **Safety.** Safety Locks hold the Platforms in place. Once engaged on the Safety Locks, the weight of the Vehicle holds the Platforms in place. If the power goes out, the Platforms stay in place.

**⚠ WARNING** Although rare, it is possible for Hydraulic Fluid in the Hydraulic Cylinders to leak, causing the Lift to slowly lower if it is not engaged on its Safety Locks. **When you are operating your Lift, only leave it on a Safety Lock or fully lowered.**

- **Adjustable height.** Multiple Lock positions put the Vehicle at just the right height for the work.

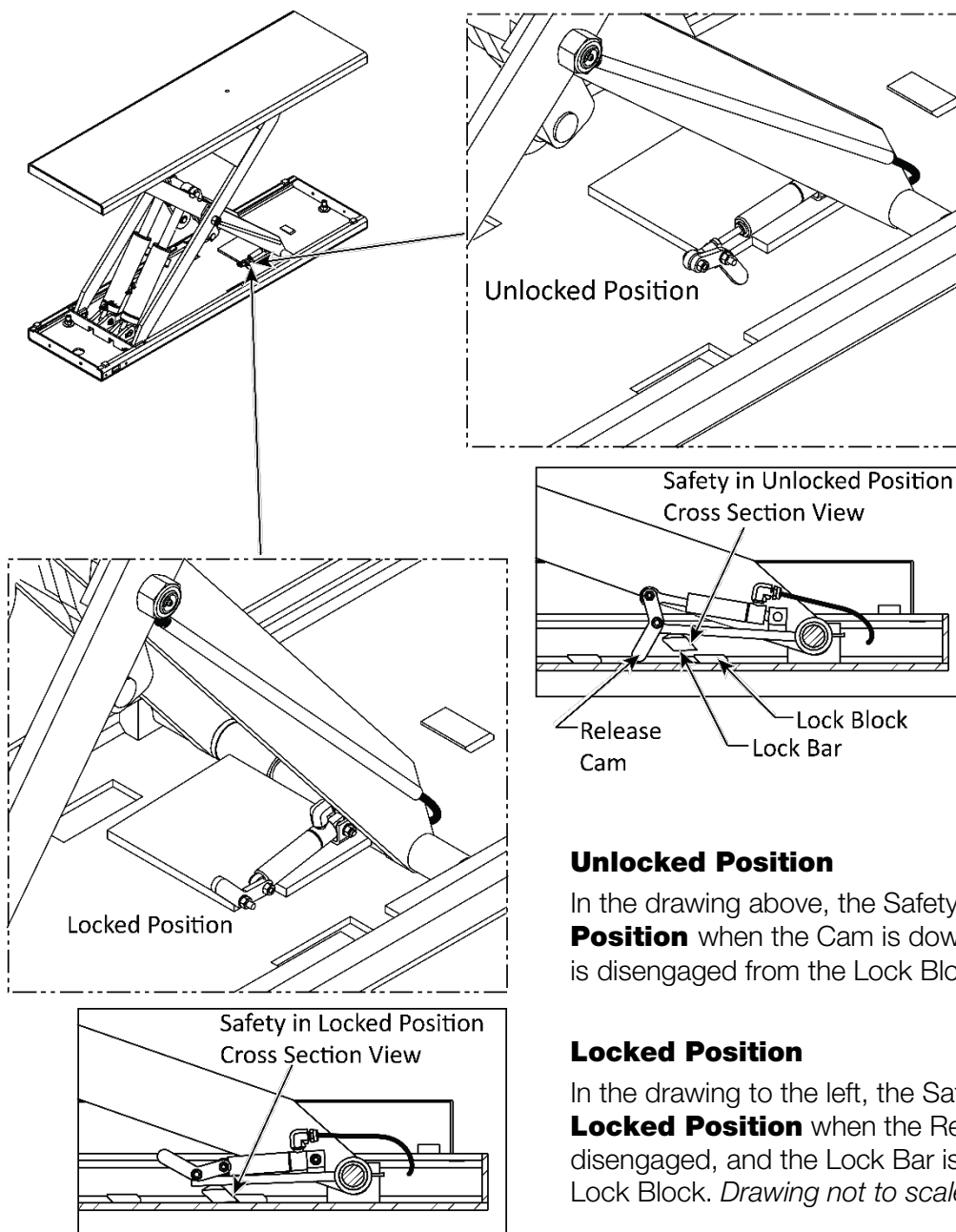

### Unlocked Position

In the drawing above, the Safety is in the **Unlocked Position** when the Cam is down, and the Lock Bar is disengaged from the Lock Block.

### Locked Position

In the drawing to the left, the Safety is in the **Locked Position** when the Release Cam is disengaged, and the Lock Bar is firmly resting on the Lock Block. *Drawing not to scale.*

---

## Lowering a Vehicle

This section describes how to lower a Vehicle from a raised position. The same instructions and warnings for raising a Vehicle apply to lowering it.

- **Never** exceed the rated capacity of this Lift, 6,000 lbs. / 2,722 kg
- **Never** exceed the Maximum load of 3,000 lbs. / 1,361 kg. per Lift side.
- **Always** center the load evenly.
- **Do not** operate the Lift if any component is found to be defective or worn.
- **Never** operate the Lift with any person or equipment under the Lift.
- **Always** ensure the Vehicle is centered and stable prior to operating the Lift controls.
- **Always** verify the Safety Locks are engaged before working on or near any Vehicle.
- **Never** leave the Lift in an elevated position unless the **Safety Locks** on **both** Platforms are engaged.
- **Never** attempt to work on or near a Vehicle when it is raised on the Platforms unless the Safety Locks are engaged.
- Do **not** permit the Power Unit to get wet. The motor can be damaged and water damage is not covered under the product warranty.

 **WARNING** Always allow a minimum of a 5-second delay between motor starts. Failure to comply may cause switch and/or Motor burnout. Neglecting this delay between starts could cause serious damage to the equipment and/or personal property.

### To lower a Vehicle:

1. Check the items listed in **Lift Operation Safety**.

If you find any issues, resolve them before lowering the Vehicle.

2. Before lowering the Vehicle, be sure all personnel, tools, and other equipment are clear of the Lift and surrounding area.
3. At the Console, press and hold the **Raise** button to elevate the Lift at least 2 inches. Raising the Lift Platform up and off the Safety Locks.
4. Press and hold the **Safety Lock Release** button.
5. Lower the Vehicle by pressing and holding the **Lower** button.  
If you do not press and hold the Safety Lock Release, the Lift will stop at the next Safety Lock.
6. While lowering the Lift, make sure that all personnel and objects are clear of the Lift and surrounding area.
7. Always keep a clear line of sight on the Lift and the Vehicle.
8. Always verify all Locks disengage when the **Safety Lock Release** button is pressed. If one of the locks inadvertently engages on descent, the Lift and /or vehicle may become unbalanced and cause serious injury or death.
9. When the Platforms are fully lowered, release both buttons.
10. Carefully drive the Vehicle off the Platforms.

---

# Maintenance

 **DANGER** Before performing any maintenance, make sure the Lift is completely disconnected from power and **cannot** be re-energized until all maintenance is complete. If the power is re-energized during maintenance, you, or someone else could be electrocuted. BendPak strongly recommends using your Power Disconnect Switch during maintenance.

If your organization has Lockout/Tag Out policies, be sure to implement them to ensure no-one can start the Lift while maintenance is in process.

Read your manual and understand how this equipment works before using, maintaining, or repairing. Routine maintenance and adjustments are the responsibility of the owner/user and are not covered under warranty.

Routine maintenance and adjustments should be carried out on a regular basis. *Unless stated otherwise, all maintenance may be performed by the owner/employer and does not require trained lift service personnel.* Replace worn, damaged or broken parts with original BendPak or BendPak approved parts or with parts that meet or exceed the original specifications.

## To maintain your Lift:

- **After one hour of use:** Check the Hydraulic Fluid levels. Refill if low.
- **Daily:** Raise the Lift to full height at least once a day. This will prolong the life of the Cylinder Seals and prevent premature leakage and spills. This also bleeds the system of any trapped air and maintains the equal lifting of the system.
- **Daily:** Keep the Lift and Lift area clean. Wipe up any Hydraulic Fluid spills.
- **Daily:** Make a visual inspection of all moving parts and check for damage or excessive wear. If you find any damaged or worn parts, take the Lift out of service until they are replaced.
- **Daily:** Make sure the Safety Locks are in good operating condition. If you find that the Safety Locks are damaged or excessively worn, take the Lift out of service until they are replaced. **Do not use your Lift if the Safety Locks are damaged or excessively worn.**
- **Weekly:** Check all controls to make sure they are functioning normally.
- **Weekly:** Check all labels on the unit. Replace them if they are illegible or missing.
- **Monthly:** Lubricate the grease fittings. BendPak recommends using White Lithium Grease or similar.
- **Monthly:** Check the Hydraulic Fluid levels. Refill if low with approved Hydraulic Fluid.
- **Every two months:** Check all Anchor Bolts to make sure they are tight. If not, tighten them.
- Any adjustments to the hydraulic system require trained Lift personnel with the proper equipment.

 **WARNING:** Never attempt to access the power unit through the rear panel of the Console. Always access the Power Unit through the front panel. The Unit is too heavy to manage through the rear panel and damage to the Power Unit or personal injury may occur.

 **WARNING:** Do not operate your Lift if you find issues; instead, take the Lift out of service, then contact your dealer, email [support@bendpak.com](mailto:support@bendpak.com), visit [bendpak.com/support](http://bendpak.com/support), or call **(800) 253-2363**, extension 196.

# Troubleshooting

**Note:** If your Lift is not functioning correctly, you must take it out of service until it is fixed.

**Important:** All repair work **must** be performed by qualified personnel.

Issue	Action to Take
Platforms move erratically or squeak when in use.	Move the Platforms up and down a few times, with a break between each; there could be residual air in the Hydraulic System. The cylinders are self-bleeding.
Platforms are stuck in the up position and will not lower with the Vehicle on the Lift.	Verify the Power Unit is being supplied electrical power and that none of the Hydraulic Hoses are pinched or leaking. Verify there is sufficient Hydraulic Fluid in the Reservoir on the Power Unit. Contact BendPak Service <a href="https://www.bendpak.com/support">bendpak.com/support</a> , or call <b>(800) 253-2363</b> , extension 196.
Hydraulic Fluid is old or dirty.	Replace the dirty fluid with clean, approved Hydraulic Fluid.
Platforms make odd noises when in use.	Lubricate hinge points using Red Lithium Grease. Lubricate the platforms where the Slide Blocks travel using White Lithium Grease.
Platforms are slowly lowering on their own.	Verify both Platforms are on Safety Locks. Only leave the Lift fully lowered or engaged on Safety Locks. Look for Hydraulic Fluid leaks.
Lift Frames cannot rise from a zero net rise position with weight on the lift.	The MDS-6 Series Lift cannot raise a full load from a completely flat position. Refer to <b>Vehicle with No Tires Fully Lowered</b> .

If you continue to have problems with your Lift, take the Lift out of service, then contact your dealer, visit [bendpak.com/support](https://www.bendpak.com/support), email [support@bendpak.com](mailto:support@bendpak.com), or call **(800) 253-2363**, extension 196.

 **WARNING:** Never attempt to access the power unit through the rear panel of the Console. Always access the Power Unit through the front panel. The Unit is too heavy to manage through the rear panel and damage to the Power Unit or personal injury may occur.

## Vehicle with No Tires - Fully Lowered

When the MDS-6 Series Lift is completely flat and there is too much weight on the Lift Platform, there is no room to develop any upward force. The weight on the Lift must be reduced by at least half or raise the Vehicle off the Lift Platform or Lift Pads in some other manner.

Methods that have resolved this issue include:

- Use a floor jack to raise the Vehicle from four to six inches.
- Using lifting equipment to raise the Vehicle. If you are still unable to raise your Vehicle, contact BendPak Technical Support for assistance.



Refer to the wiring schematics below to connect power and the Console control pushbuttons. A Power Disconnect Switch and an External Thermal Overload Protection device in accordance with the National Electrical code and CE code Part 1, **must be provided by a licensed Electrician**. The wiring providing power to this unit must be rated for 3 H.P., 1 Phase, 208-240 Volt, 50/60 Hz.

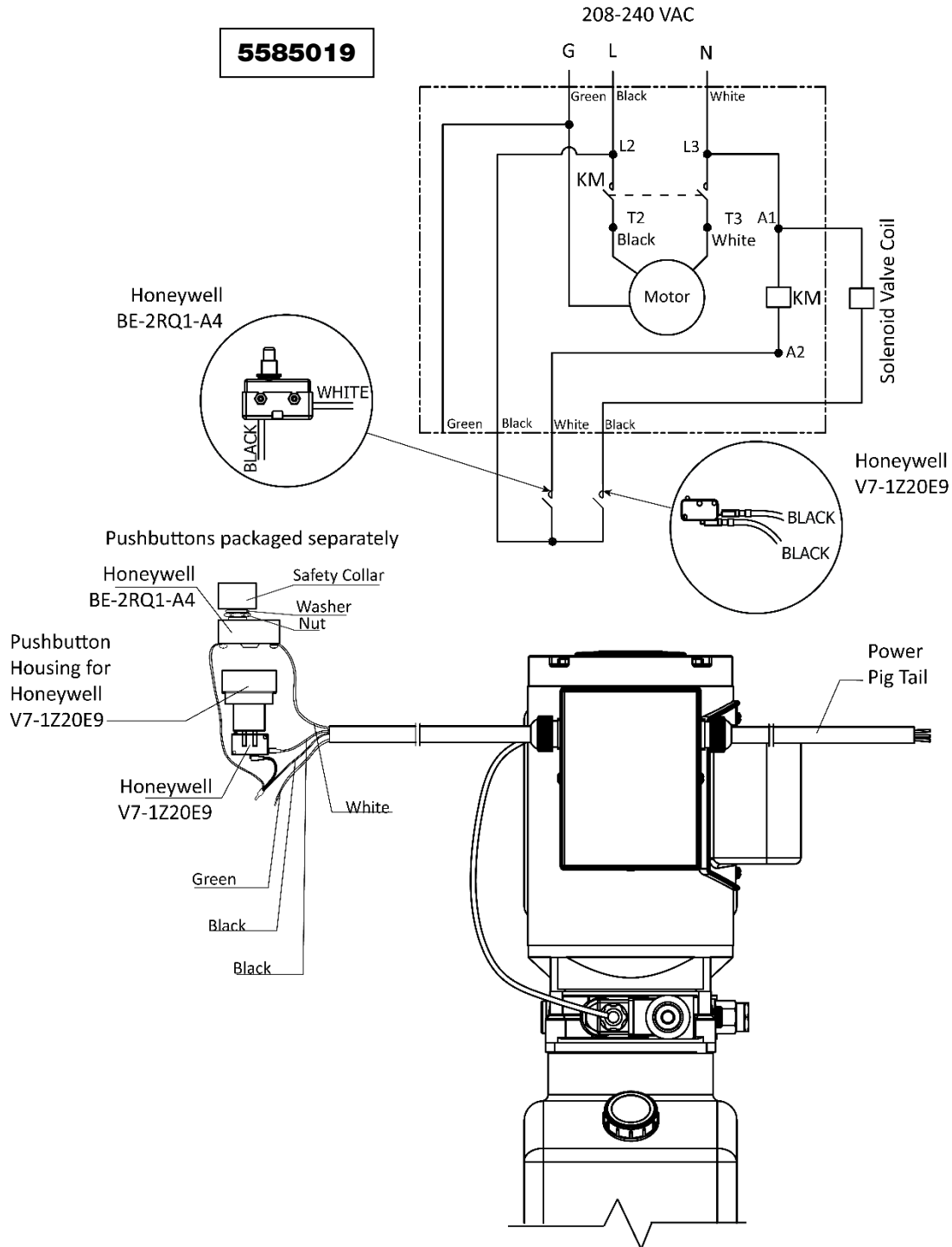

*Drawing not to scale.*

Refer to the wiring schematics below to connect power and the Console control pushbuttons. A Power Disconnect Switch and an External Thermal Overload Protection device in accordance with the National Electrical code and CE code Part 1, **must be provided by a licensed Electrician**. The wiring providing power to this unit must be rated for 1 H.P., 1 Phase, 110/120 Volt, 50/60 Hz.

**5585002**

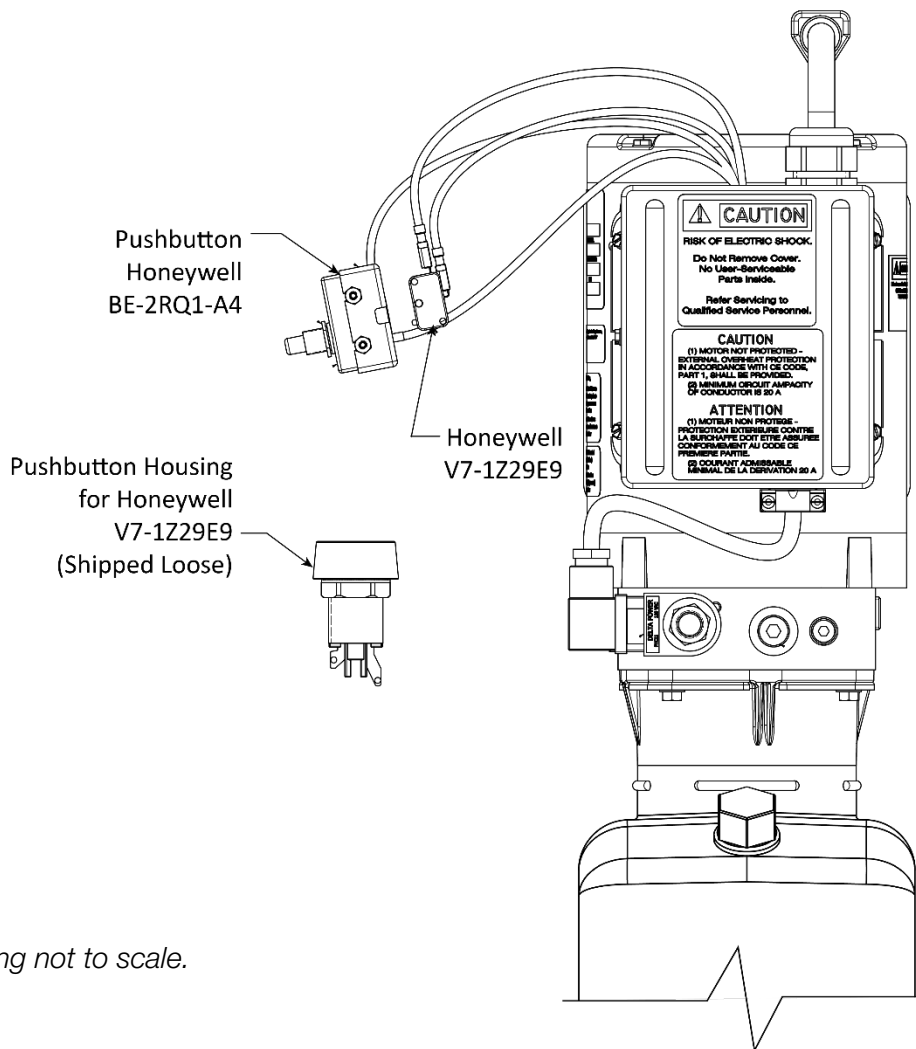
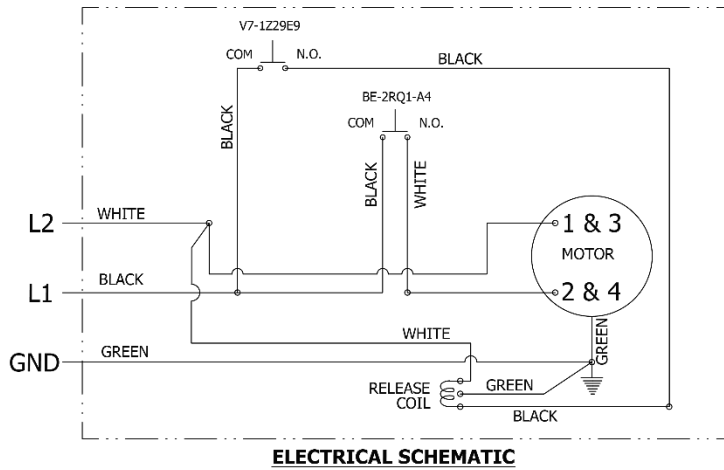

*Drawing not to scale.*

# Labels

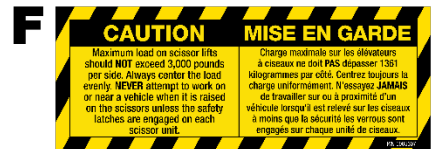
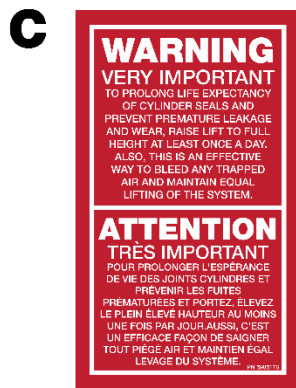

**I**



**WARNING** **ATTENTION**

**DRIVE CAR COMPLETELY OVER LIFT**  
CONDUISSEZ LA VOTRE COMPLETEMENT SUR L'ASCENSSEUR

**NEVER OVERLOAD LIFT** Check for 1" minimum clearance between top and lift before loading.  
**NE JAMAIS SURCHARGER L'ASCENSSEUR** Vérifier le décalage minimum de 1" entre le cabine et l'ascenseur avant de charger.

**DO NOT park on or load lift in a fully lowered position or damage may result.**  
**NE PAS stationner ni charger l'ascenseur dans une position abaissée ou des dommages peuvent en résulter.**

**SAFETY IN LOCKED POSITION**  
Preload Car and Lock Bar  
Lock the bar in position.  
Release Car - Jetez la Car - Release or unmount.  
Lock the bar in position.

**SAFETY IN UNLOCKED POSITION**  
Preload Car and Lock Bar  
Release Car - Jetez la Car - Release or unmount.  
Lock the bar in position.

**SECURITE EN POSITION VERROUILLEE**  
Effleurer la barre « L » dans la configuration soulevée et la barre de verrouillage (K) et la barre de verrouillage (K).

**SECURITE EN POSITION DEVERROUILLEE**  
Effleurer la barre « L » dans la configuration soulevée et la barre de verrouillage (K) et la barre de verrouillage (K).

**NOTICE**

If attachments, accessories, or configuration modifying components used on this lift are located in the load path and affect operation of the lift, affect the lift electrical listing, or affect intended vehicle accommodation; and if they are not certified for use on this lift, then the certification of this lift shall become null and void. Contact the participant for information pertaining to certified attachments, accessories, or configuration modifying components.

**LP MODELS ONLY**

www.autolift.org ©2011 by ALI, Inc. ALI / WLSIA01

**WARNING** This power unit contains a hydraulic pump that is capable of developing pressure in excess of 5,000 psi (345 BAR). A pressure relief valve is used to set the pressure at the desired level. Tampering with, adjusting, modifying, or removing the relief valve is extremely dangerous and is not recommended. Only a trained hydraulic technician, using a calibrated hydraulic pressure gauge to assure the proper pressure setting is achieved, should make adjustments to the relief valve.

**ADVERTENCIA** Esta central hidráulica contiene una bomba capaz de desarrollar una presión en exceso de 5.000 psi (345 BAR). La presión está establecida por la válvula de descarga al nivel de presión deseada. El extremar o modificar la presión, utilizando un manómetro hidráulico calibrado para asegurar que la propia presión es alcanzada, podrá hacer modificaciones a la válvula de descarga.

**ADVERTENCIA:** Cambios a la salida de presión, podrían hacer la central hidráulica incompatible con las limitaciones de presión de otros componentes en el circuito hidráulico. Esos componentes pueden funcionar mal causando una catástrofe y poder resultar en daño a la propiedad, serio daño personal o muerte.

**WARNING** Dieses Hydraulikaggregat beinhaltet eine Pumpe, welche einen Betriebsdruck bis zu 345 bar aufbauen kann. Ein integriertes Druckbegrenzungsventil begrenzt diesen Betriebsdruck. Missbrauch, verändern oder Entfernen dieses Ventils, sind extrem gefährlich und dürfen nicht zu empfehlen. Nur qualifiziertes Personal mit Hydraulikerfahrung, sollte unter Verwendung eines kalibrierten Manometers den Druck dieses Sicherheitsventils einstellen.

**ADVERTISSEMENT** Cet équipement utilise une pompe hydraulique capable de fournir une pression de 345 bar. Une soupape de sûreté est utilisée pour régler la pression à la valeur souhaitée. Manipulations, réglages, modifications ou suppression de cette soupape de sûreté peuvent se révéler très dangereux et ne sont absolument pas recommandés. Uniquement un hydraulicien qualifié, utilisant un manomètre pour permettre l'affichage précis de la pression, pourra assurer les réglages de la soupape de sûreté.

**AVERTISSEMENT:** Tout changement de la valeur de la pression de sortie peut rendre incompatible l'utilisation de cet équipement avec les autres composants du circuit hydraulique. Ceux-ci peuvent être endommagés de manière définitive et peuvent causer des dégâts matériels, ainsi que des risques de blessures sérieuses ou la mort.

**WARNING** Always allow a minimum 2-second delay between motor starts. Failure to comply may cause switch and/or motor burnout. This could cause serious damage to the equipment and/or personal property.

**RISK OF EXPLOSION** This equipment has internal arcing or sparking parts which should not be exposed to flammable vapors. **THIS EQUIPMENT SHOULD BE LOCATED AT LEAST 460 MM (18 INCHES) ABOVE THE FLOOR.** All wiring must be performed by a certified electrician only. It is the responsibility of the electrician to ensure that all field wiring systems comply with both NEC recommendations and all additional electrical codes.

**ATTENTION** Prévoyez toujours un délai minimum de 2 secondes entre les démarrages du moteur. Le non-respect de cette consigne peut entraîner l'épuisement des commutateurs et/ou du moteur. Cela pourrait causer de graves dommages à l'équipement et/ou aux biens personnels.

**RISQUE D'EXPLOSION** Cet équipement comporte des pièces internes produisant des arcs électriques ou des étincelles qui ne doivent pas être exposées à des vapeurs inflammables. **CET EQUIPEMENT DOIT ÊTRE SITUÉ AU MOINS 460 MM (18 POUCES) AU-DESSUS DU SOL.** Tout le câblage doit être effectué par un électricien certifié. Il incombe à l'électricien de s'assurer que tous les systèmes de câblage sur site sont conformes aux recommandations NEC et à tous les codes électriques supplémentaires.

**CAUTION** Power Unit: Secure placard near lift controls. **CAUTION** Lift to be used by trained operator only. **CAUTION** Authorized personnel only in lift area. **NOTICE** Read operating and safety manuals before using lift.

**CAUTION** Use vehicle manufacturer's lift points. **CAUTION** Always use safety stands when removing or installing heavy components. **NOTICE** Proper maintenance and inspection is necessary for safe operation. **NOTICE** Do not operate a damaged lift.

The messages and paragraphs shown are generic. In future and see "Notes" to generally represent hazards common to all scissor lifts regardless of specific type. Funding for the development and validation of these labels was provided by the Automated Lift Institute, P.O. Box 85, Coland, NY 13845. Replacement label sets may be obtained from the original lift manufacturer and ALI's member companies. They are protected by copyright. www.autolift.org ©2011 by ALI, Inc. ALI P/N 180606

**CAUTION**

- Motor not protected - external overheat protection in accordance with CE code, Part 1, shall be provided.
- Minimum circuit ampacity of conductor is 30A.

**PRECAUCIÓN**

- Motor no está protegido - se proveerá protección contra sobrecalentamiento externo de conformidad con el código CE, Sección 1.
- Ampacidad mínimo del conductor del circuito es 30A.

**ATTENTION**

- Moteur non protégé - une protection externe contre la surchauffe conforme au code CE, Partie 1, doit être fournie.
- L'ampacité minimale du circuit du conducteur est de 30A.

If connected to a circuit protected by fuses use time-delay fuse Marked D

Si está conectado a un circuito protegido por fusibles, utilice fusibles de acción retardada, tipo D

Si connecté à un circuit protégé par fusibles utilisez fusible temporisé Marqué D

REV.1119

# Parts Diagrams

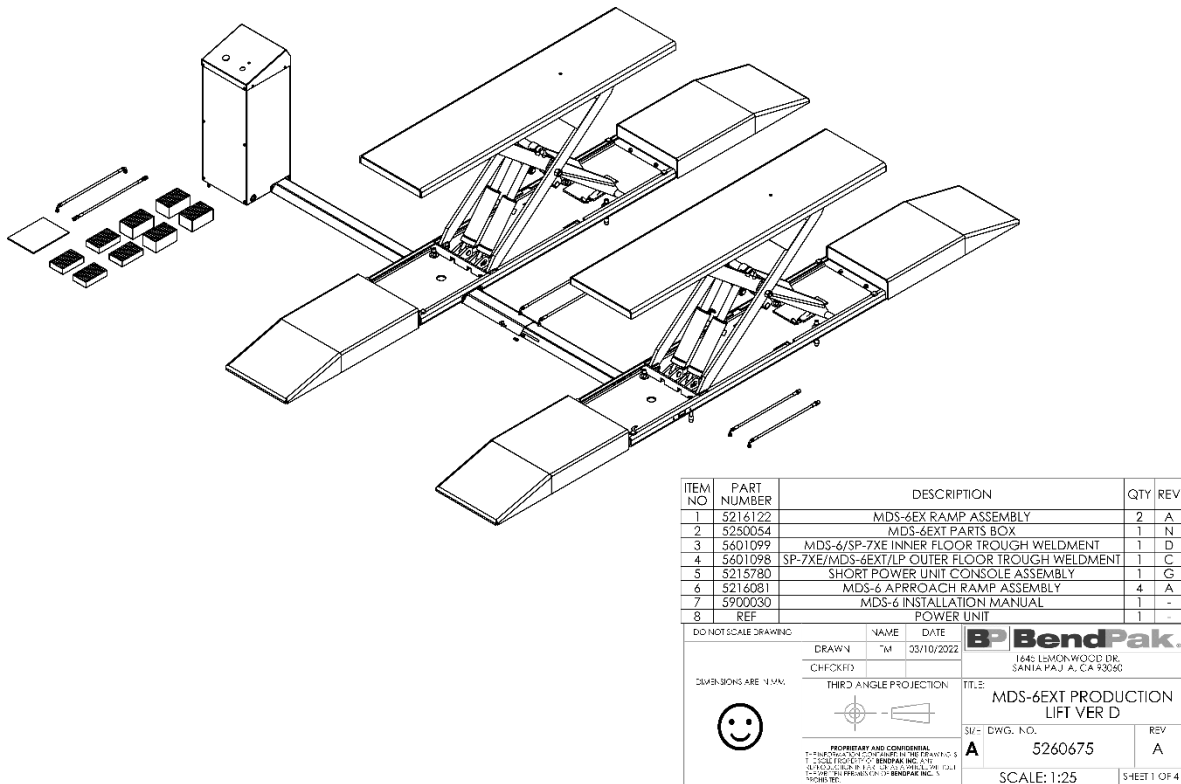
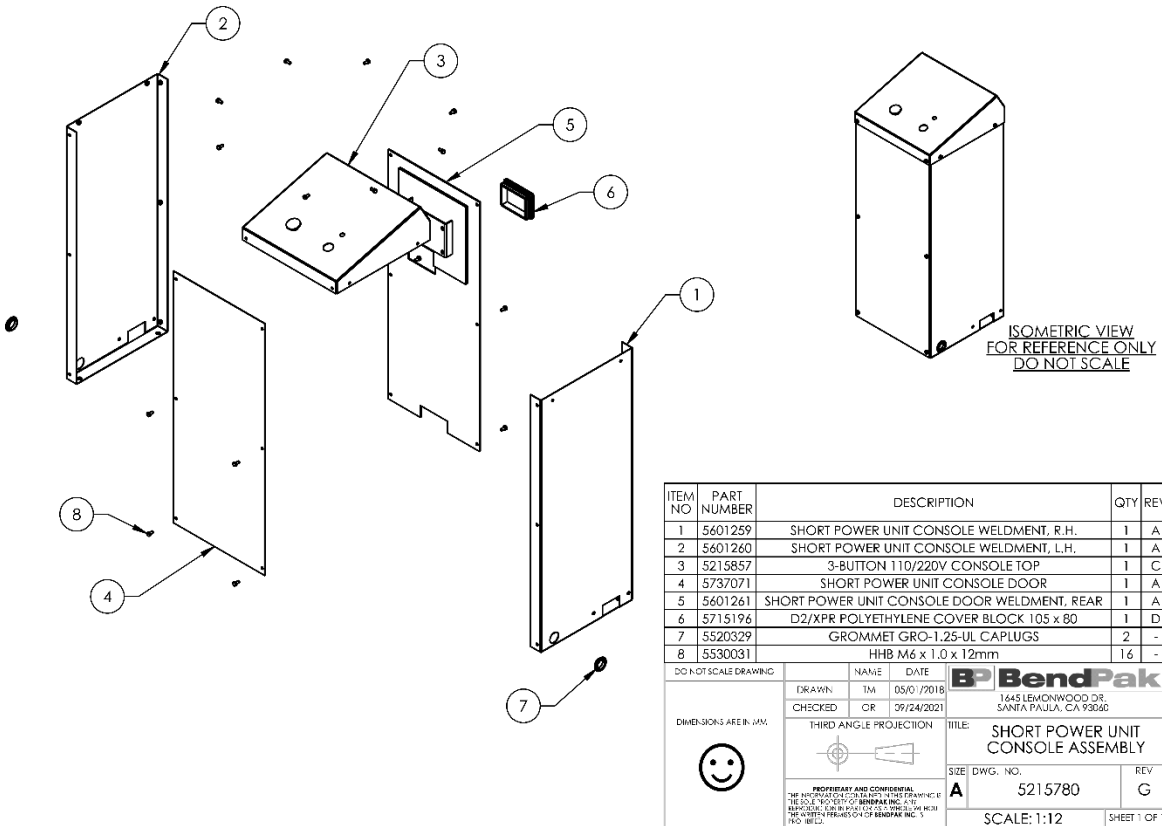

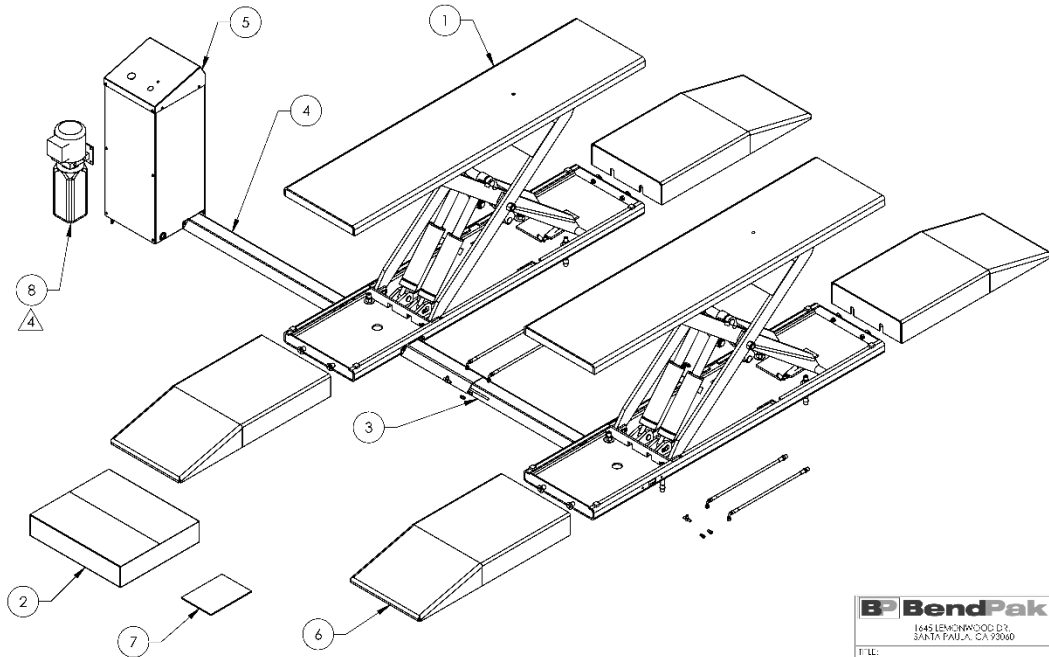

<b>BP BendPak</b>		
1645 LEWISWOOD DR. SANTA PAULA, CA 93060		
TITLE: MDS-6EXT PRODUCTION LIFT VER D		
SIZE	DWG. NO.	REV
A	5260675	A
SCALE: 1:20		SHEET 2 OF 4

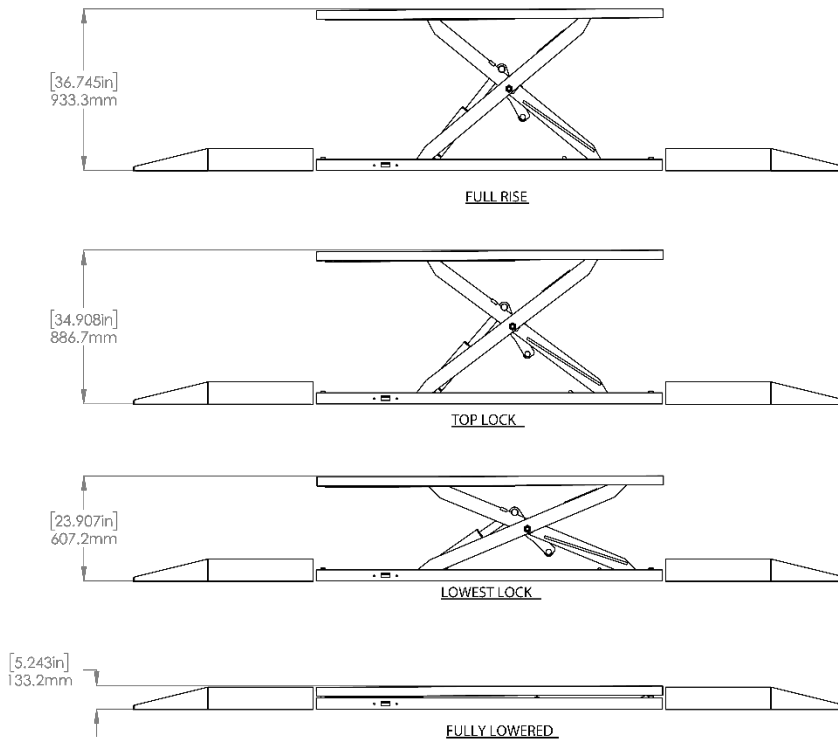

<b>BP BendPak</b>		
1645 LEWISWOOD DR. SANTA PAULA, CA 93060		
TITLE: MDS-6EXT PRODUCTION LIFT VER D		
SIZE	DWG. NO.	REV
A	5260675	A
SCALE: 1:25		SHEET 3 OF 4

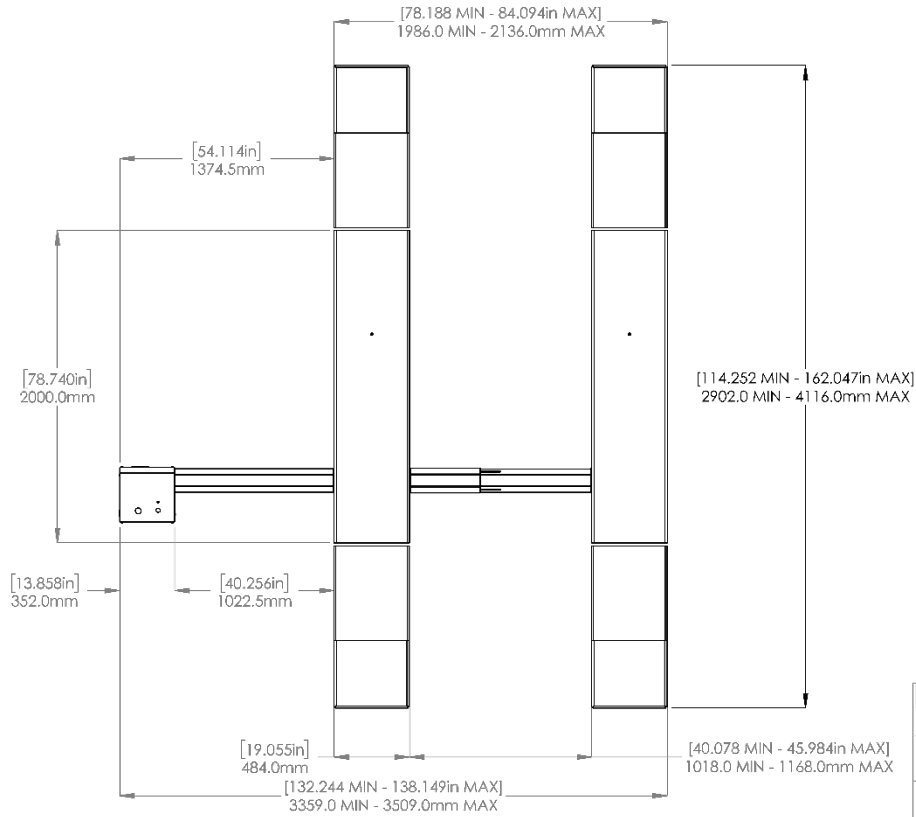

**BendPak**  
1645 LEXON WOOD DR.  
SANTA PAULA, CA 93860

TITLE:  
**MDS-6EX PRODUCTION  
LIFT VER D**

S/A	DWG. NO.	REV
<b>A</b>	<b>5216122</b>	<b>A</b>

SCALE: 1:28 SHEET 4 OF 4

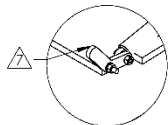

DETAIL A  
SCALE 1 : 5

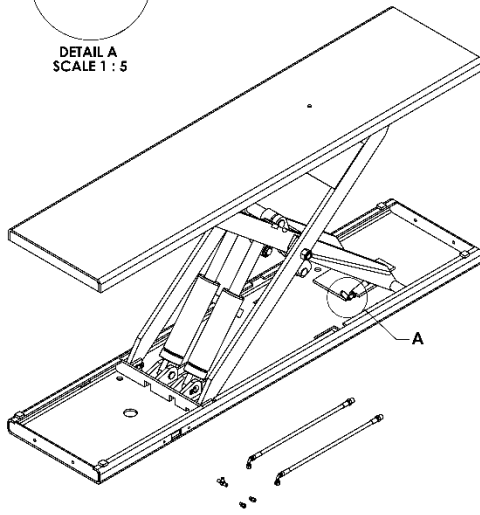

⚠ 5736890 MUST ROTATE FREELY

ITEM NO	PART NUMBER	DESCRIPTION	QTY	REV
1	5601797	MDS-6EX BASE WELDMENT	1	A
2	5601021	MDS-6 INNER SCISSOR WELDMENT	1	G
3	5600745	MDS-6 OUTER SCISSOR WELDMENT	1	J
4	5601533	MDS-6 EX RAMP WELDMENT	1	A
5	5716202	MDS-6 SCISSOR BOTTOM SLIDE BLOCK 46mm	2	B
6	5716184	MDS-6 SCISSOR TOP SLIDE BLOCK 59mm	2	D
7	5746316	MDS-6 RAMP PIN	1	F
8	5601530	MDS-6 SCISSOR CLEVIS PIN WELDMENT	4	B
9	5530532	NUT M24 x 3.0 NL	2	...
10	5736690	MDS-6 SAFETY ROCKER ARM	1	B
11	5545005	WASHER, M6 x 12mm FLAT	2	...
12	5535357	NUT M6 x 1.0 NL	3	...
13	5502195	AIR CYLINDER Ø19mm x 25 STROKE	1	...
14	5530093	HHB M6 x 1.0 x 20mm	1	...
15	5530757	HHB M6 x 1.0 x 40	1	...
16	5505625	FEMALE ROD END M6 x 33	1	...
17	5600747	MDS-6 CYLINDER GUIDE WELDMENT	1	F
18	5215475	MDS-6 SERIES CYLINDER GUIDE ARM ROLLER ASSEMBLY	2	B
19	5505136	SPRING PIN M5 x 40	2	...
20	5744631	BEARING SPACER 244 x Ø30 x 2	2	A
21	5502032	CYLINDER ASSEMBLY Ø3.0 x 7.5	2	J
22	5746700	MDS-6 SERIES CYLINDER GUIDE PIN, LARGE	1	C
23	5530374	SSS M8 x 1.25 x 16 EXTENDED NL	2	...
24	5530310	FTG TEE -Ø4JIC -Ø4JIC -Ø4JIC	1	...
25	5530001	FTG NPL Ø4 COMP x Ø2 NPT	2	...
26	5530087	FTG ELB -Ø4 COMP x -Ø2 NPT	1	...
27	5756033	MDS-6 CYLINDER SEPARATOR	1	C
28	5570060	MDS-6 SERIES HYDRAULIC HOSE ASSY Ø6.35 x 294mm SS	2	D
29	5545001	WASHER 25mm x 37mm	2	...
30	5530031	HHB M6 x 1.0 x 12mm	6	...

DATE: 05/11/2022

**BendPak**  
1645 LEXON WOOD DR.  
SANTA PAULA, CA 93860

TITLE:  
**MDS-6EX RAMP ASSEMBLY**

S/A	DWG. NO.	REV
<b>A</b>	<b>5216122</b>	<b>A</b>

SCALE: 1:15 SHEET 1 OF 2

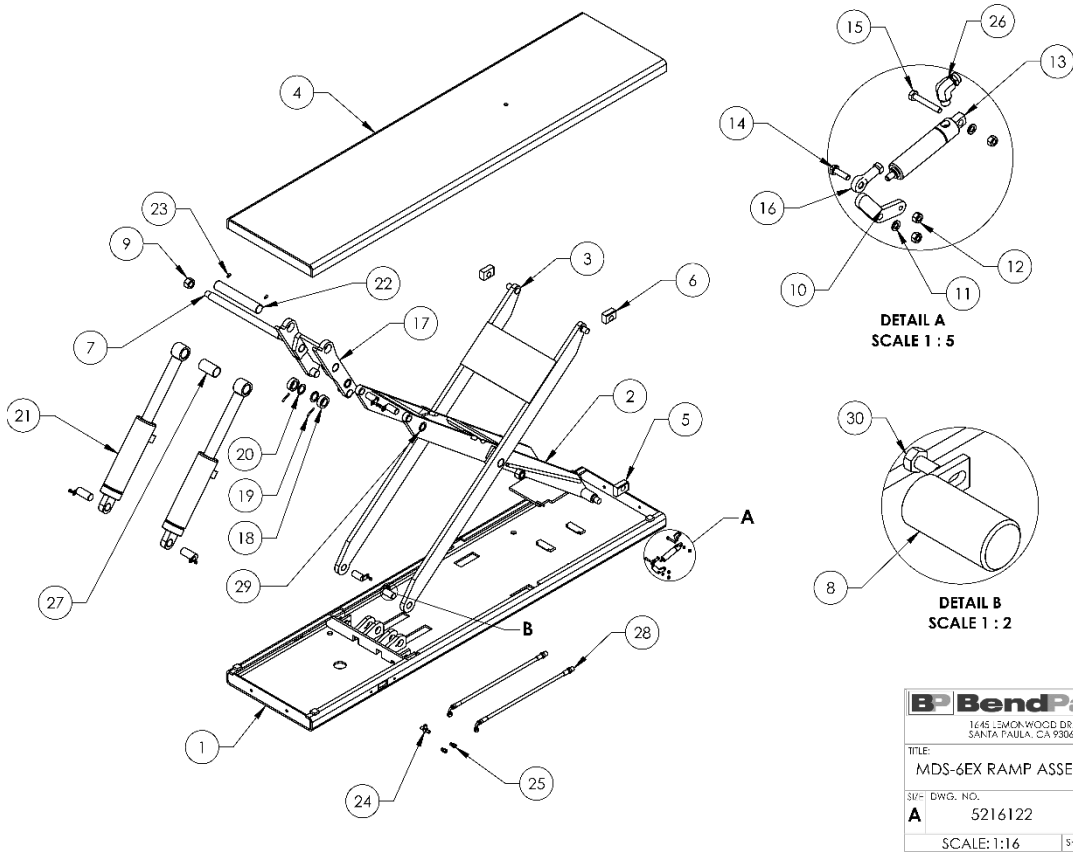

<b>BendPak</b>	
1645 E. SMOKWOOD DR. SANTA PAULA, CA 93060	
TITLE: MDS-6EX RAMP ASSEMBLY	
SIZE	REV
A	A
SCALE: 1:16	SHEET 2 OF 2

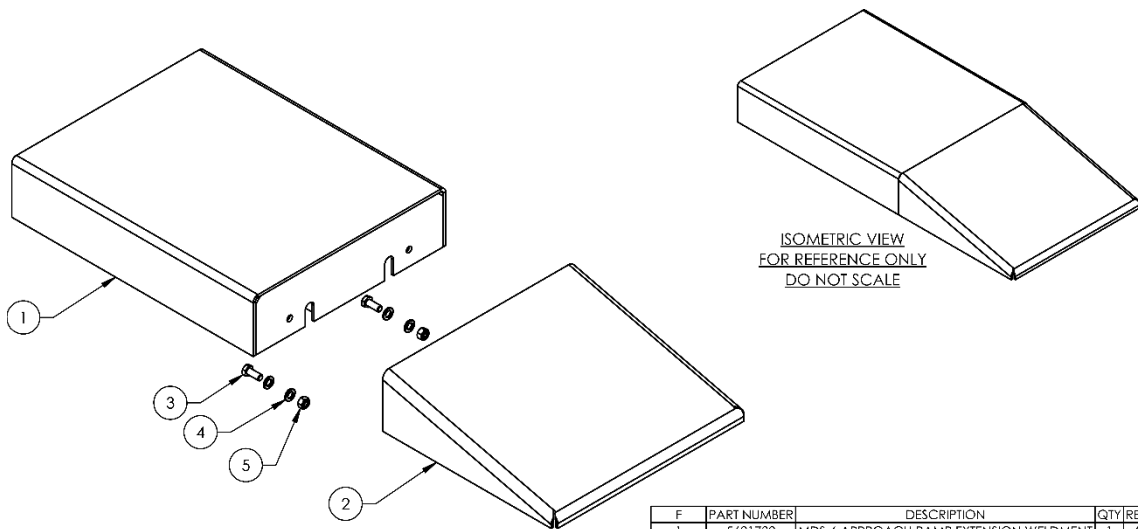

F	PART NUMBER	DESCRIPTION	QTY	REV
1	5601730	MDS-6 APPROACH RAMP EXTENSION WELDMENT	1	A
2	5601731	MDS-6 SHORT APPROACH RAMP WELDMENT	1	A
3	5530563	HHB M12 x 1.75 x 30 CL10.9	2	-
4	5545347	WASHER, M12 FLAT WASHER	4	-
5	5535041	NUT M12 x 1.75 NL CL10.9	2	-

DID NOT SCALE DRAWINGS		NAME	DATE	<b>BendPak</b>
DRAWN	CA	09/30/2021	1645 E. SMOKWOOD DR. SANTA PAULA, CA 93060	
CHECKED	OR	09/22/2021		
THIRD ANGLE PROJECTION		TITLE:		
MDS-6 APPROACH RAMP ASSEMBLY		SIZE	REV	
A		5216081	A	
SCALE: 1:8		SHEET 1 OF 2		

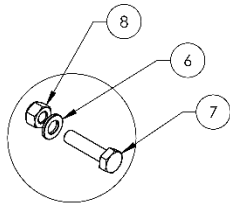

DETAIL A  
SCALE 1:2

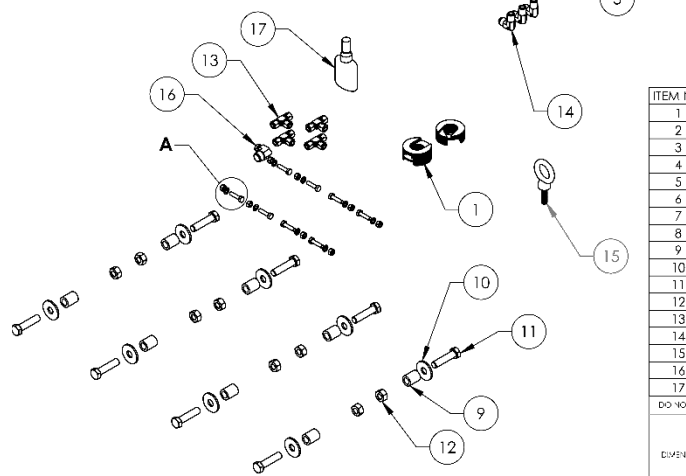

ITEM NO	PART NUMBER	DESCRIPTION	QTY	REV
1	5545535	C WASHER SHIM FOR LIFTS	20	--
2	5550103	FTG ELB -04 JIC -06 ORB	1	--
3	5550100	FTG NPL -04 JIC x -06 NPT	3	--
4	5545340	WASHER M8 x24 FLAT	4	--
5	5530304	HHB M8 x 1.25 x 20	4	--
6	5545005	M6 FLAT WASHER	8	--
7	5530756	HHB M6 x 1 x 25	8	--
8	5535357	NUT M6 x 1.0 NL	8	--
9	5755155	MDS-6K DRIVE UP RAMP BOLT SPACER	8	B
10	5545027	WASHER M12 x Ø37 x 3mm	8	--
11	5530193	HHB M12 x 1.75 x 50	8	--
12	5535012	NUT M12x1.75 NL	8	--
13	5550395	FTG TEE -04 COMP x -04 COMP x -04 COMP	4	--
14	5550106	FTG ELB -04 JIC x 3/8" NPT	3	--
15	5530788	EYE M10 x 1.5 x 28 ID	1	--
16	5550087	FTG ELB -04 COMP x -06 NPT	1	--
17	5580012	LIQUID PTFE THREAD SEALANT 50ml	1	--

DO NOT SCALE DRAWING	NAME	DATE	
	DRAWN TM	07/28/2014	
	CHECKED CR	04/03/2020	1645 L-MONWOOD DR. SANTA PALA, CA 95069
DIMENSIONS ARE IN MM	THIRD ANGLE PROJECTION		TITLE: MDS-6EXT/LP PARTS BAG S/F: A DWG. NO. 5174018 REV K SCALE: 1:8 SHEET 1 OF 1

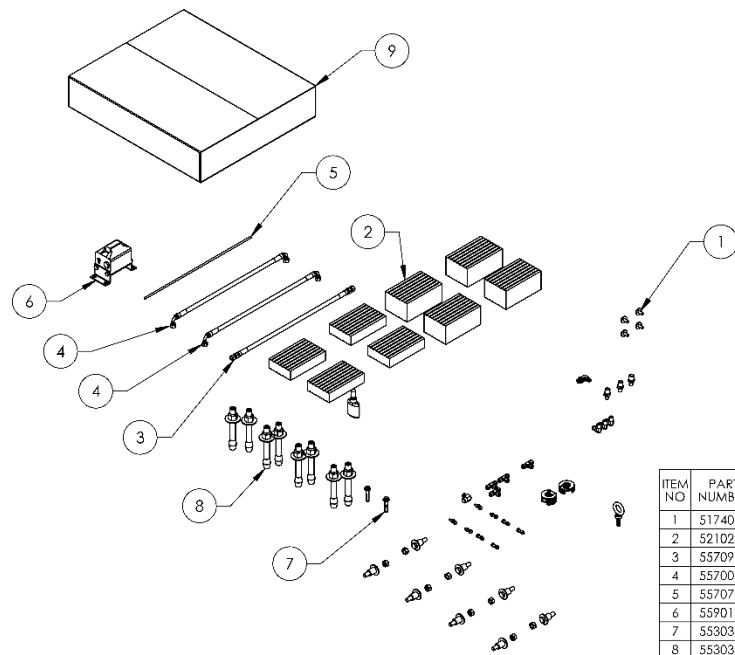

ITEM NO	PART NUMBER	DESCRIPTION	QTY	REV
1	5174018	MDS-6EXT/LP PARTS BAG	1	K
2	5210232	LOW RISE SCISSOR LIFT RUBBER PAD KIT, SET OF 8	1	A
3	5570911	MDS-6 SERIES HYDRAULIC HOSE ASSY Ø6.35 x 458mm DS	1	B
4	5570081	HYDRAULIC HOSE ASSEMBLY Ø6.35 x 3352mm DB	2	B
5	5570795	1/4" POLY-FLO TUBING	9260mm*	--
6	5590104	HYDRAULIC FLOW DIVIDER CAST IRON; ST	1	--
7	5530326	AB Ø3/8" x 2-1/4"	2	--
8	5530307	AB 3/4" x 5"	8	--
9	5250054-1	MDS-6EXT/EXTF PARTS BOX	1	--

DO NOT SCALE DRAWING	NAME	DATE	
	DRAWN TM	07/26/2016	
	CHECKED		1645 L-MONWOOD DR. SANTA PALA, CA 95069
DIMENSIONS ARE IN MM	THIRD ANGLE PROJECTION		TITLE: MDS-6EXT PARTS BOX S/F: A DWG. NO. 5250054 REV N SCALE: 1:15 SHEET 1 OF 1

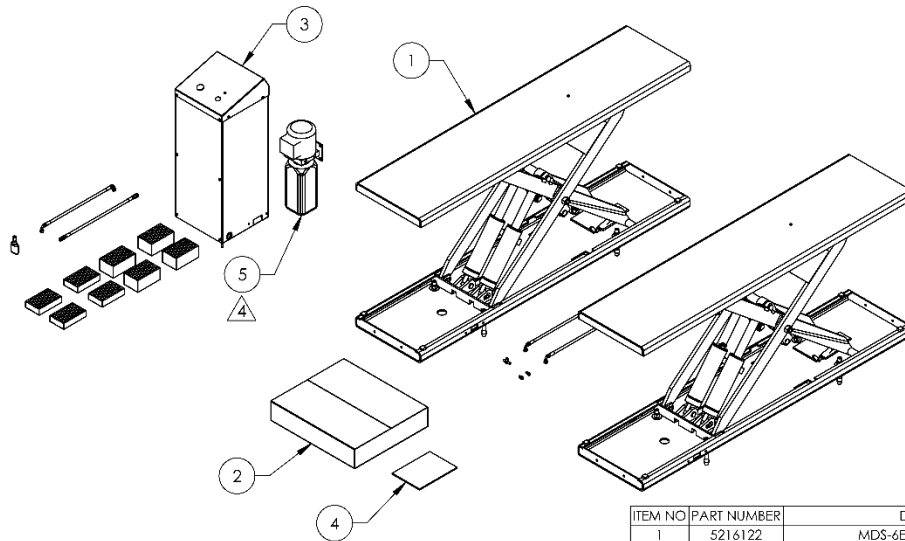

△ 4. POWER UNIT REFERENCE ON PURCHASE ORDER

ITEM NO	PART NUMBER	DESCRIPTION	QTY	REV
1	5216122	MDS-6EX RAMP ASSEMBLY	2	A
2	5250062	MDS-6EXTF PARTS BOX	1	J
3	5215780	SHORT POWER UNIT CONSOLE ASSEMBLY	1	G
4	5900030	MDS-6 INSTALLATION MANUAL	1	-
5	REF	POWER UNIT	1	-

DON'T SCALE DRAWING		NAME	DATE	 1645 LEWISWOOD DR. SANTA PAULA, CA 93060
DRAWN	TM	03/09/2022		
DIMENSIONS ARE IN MM		THIRD ANGLE PROJECTION		TITLE: MDS-6EXTF PRODUCTION LIFT VER D
				SIZE DWG. NO. REV A 5260676 A
<small>           PROPRIETARY AND CONFIDENTIAL            INFORMATION - BENDPAK INC. IS NOT TO BE            REPRODUCED OR TRANSMITTED IN ANY FORM            OR BY ANY MEANS, ELECTRONIC OR MECHANICAL,            INCLUDING PHOTOCOPYING, RECORDING, OR BY            ANY INFORMATION STORAGE AND RETRIEVAL            SYSTEMS. BENDPAK INC. © 2022         </small>				SCALE: 1:25 SHEET 1 OF 3

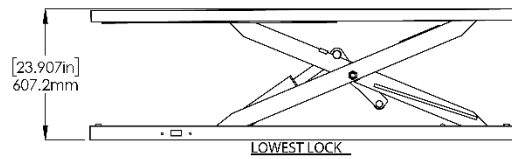
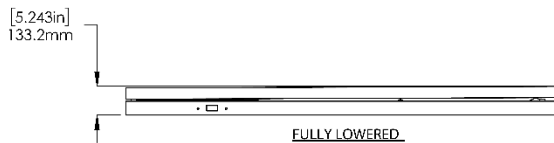
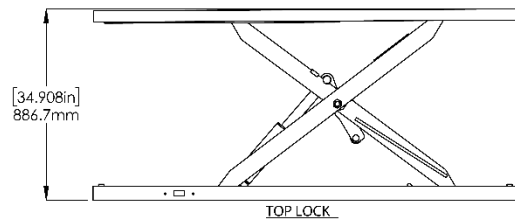
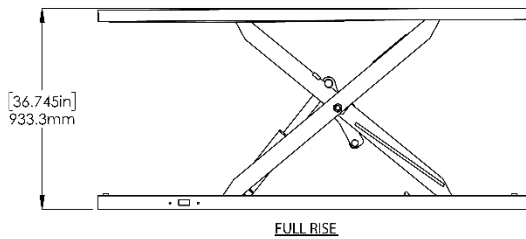

 1645 LEWISWOOD DR. SANTA PAULA, CA 93060	
TITLE: MDS-6EXTF PRODUCTION LIFT VER D	
SIZE DWG. NO. REV A 5260676 A	SCALE: 1:20 SHEET 2 OF 3

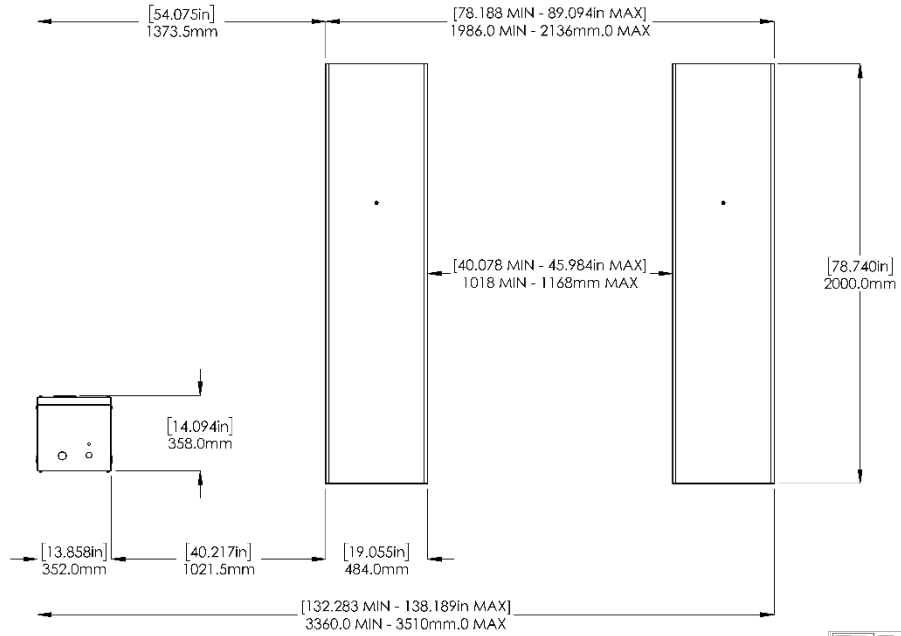

**BendPak**  
 1645 LEMONWOOD DR.  
 SANTA PAULA, CA 93060

TITLE: MDS-6EXTF  
 PRODUCTION LIFT VER D

SPEL DWG. NO. 5260676 REV A

SCALE: 1:20 SHEET 3 OF 3

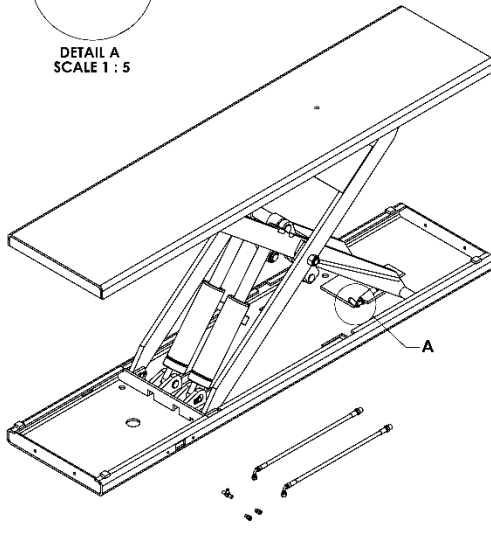
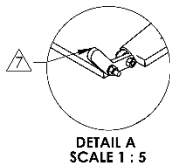

ITEM NO	PART NUMBER	DESCRIPTION	QTY	REV
1	5601797	MDS-6EX BASE WELDMENT	1	A
2	5601021	MDS-6 INNER SCISSOR WELDMENT	1	G
3	5600745	MDS-6 OUTER SCISSOR WELDMENT	1	J
4	5601533	MDS-6EX RAMP WELDMENT	1	A
5	5716202	MDS-6 SCISSOR BOTTOM SLIDE BLOCK 46mm	2	B
6	5716184	MDS-6 SCISSOR TOP SLIDE BLOCK 39mm	2	D
7	5746316	MDS-6 RAMP PIN	1	F
8	5601530	MDS-6 SCISSOR CLEVIS PIN WELDMENT	4	B
9	5535032	NUT M24 x 3.0 NL	2	
10	5736990	MDS-6 SAFETY ROCKER ARM	1	B
11	5545005	WASHER M6 x 12mm FLAT	2	
12	5535357	NUT M6 x 1.0 NL	3	
13	5502195	AIR CYLINDER, Ø19mm x 25 STROKE	1	
14	5530093	HHB M6 x 1.0 x 20mm	1	
15	5530757	HHB M6 x 1.0 x 40	1	
16	5505625	FEMALE ROD END M6 x 33	1	
17	5600747	MDS-6 CYLINDER GUIDE WELDMENT	1	F
18	5215475	MDS-6 SERIES CYLINDER GUIDE ARM ROLLER ASSEMBLY	2	B
19	5505136	SPRING PIN M5 x 40	2	
20	5746431	BEARING SPACER, Ø44 x Ø30 x 2	2	A
21	5502032	CYLINDER ASSEMBLY Ø3.0 x 7.5	2	J
22	5746700	MDS-6 SERIES CYLINDER GUIDE PIN LARGE	1	C
23	5530374	SSS M8 x 1.25 x 16 EXTENDED NL	2	
24	5550310	FTG TEE-Ø4JIC-Ø4JIC	1	
25	5550001	FTG NPL-Ø4 COMP x-Ø2 NPT	2	
26	5550087	FTG ELB-Ø4 COMP x-Ø2 NPT	1	
27	5756033	MDS-6 CYLINDER SEPARATOR	1	C
28	5570060	MDS-6 SERIES HYDRAULIC HOSE ASSY Ø6.35 x 254mm SB	2	D
29	5545001	WASHER 25mm x 37mm	2	
30	5530031	HHB M6 x 1.0 x 12mm	6	

REV: NOT SCALE DRAWING

DRAWN: IM 03/10/2022  
 CHECKED: OF 05/11/2022

**BendPak**  
 1645 LEMONWOOD DR.  
 SANTA PAULA, CA 93060

TITLE: MDS-6EX RAMP ASSEMBLY

SPEL DWG. NO. 5216122 REV A

SCALE: 1:15 SHEET 1 OF 2

THIRD ANGLE PROJECTION

PROHIBITED AND CONFIDENTIAL  
 REPRODUCTION OR DISSEMINATION OF THIS DRAWING OR ANY PART THEREOF WITHOUT THE WRITTEN PERMISSION OF BENDPAK INC. IS STRICTLY PROHIBITED.

7. 5736890 MUST ROTATE FREELY

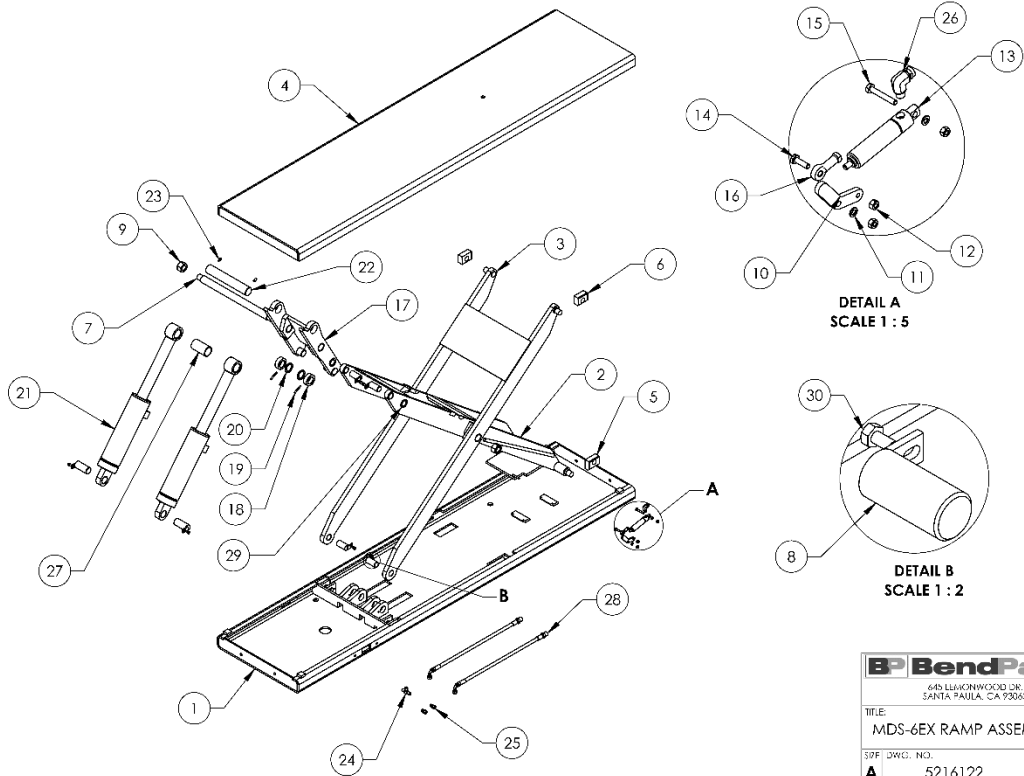

<b>BendPak</b>	
645 ELKWOOD DR. SANTA PAULA, CA 93060	
TITLE: MDS-6EX RAMP ASSEMBLY	
SUF: <b>A</b>	DWG. NO.: 5216122
REV: <b>A</b>	SCALE: 1:16
S 1.1.1 2 CI 2	

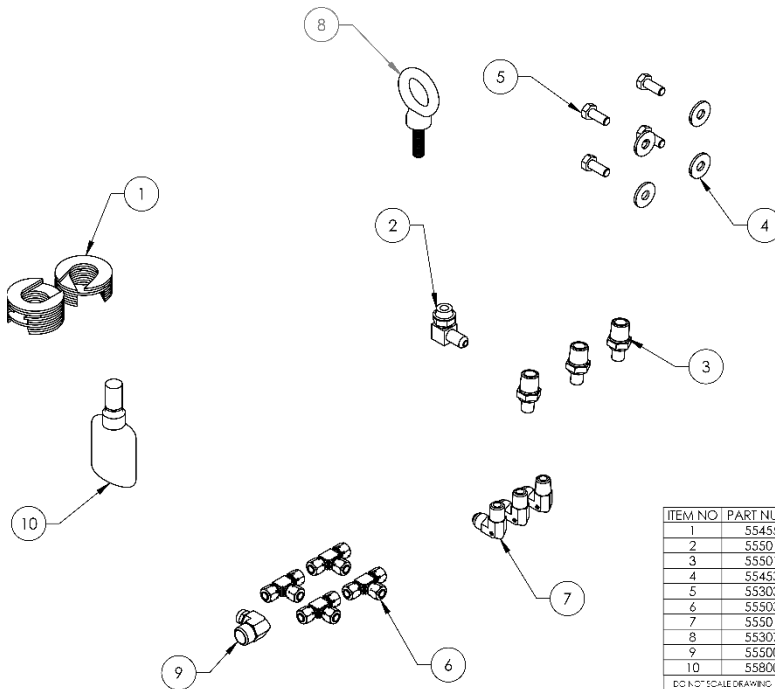

ITEM NO.	PART NUMBER	DESCRIPTION	QTY	REV
1	5545335	C WASHER SHIM FOR LIFTS	20	--
2	5550103	FTG ELB -04 JIC -06 ORB	1	--
3	5550100	FTG NPL -04 JIC x -06 NPT	3	--
4	5545340	WASHER M8 x24 FLAT	4	--
5	5530304	HHB M8 x 1.25 x 20	4	--
6	5550395	FTG TEE -04 COMP x -04 COMP x -04 COMP	4	--
7	5550106	FTG ELB -04JIC x 3/8" NPT	3	--
8	5530788	EYE M10 x 1.5 x 28 ID	1	--
9	5550089	FTG ELB -04 COMP x -06 NPT	1	--
10	5580012	LIQUID PTFE THREAD SEALANT 50ml	1	--

DO NOT SCALE DRAWING	NAME:	DATE:	<b>BendPak</b> 645 ELKWOOD DR. SANTA PAULA, CA 93060
DRAWN: TM	01/31/2017		
CHECKED: OR	04/03/2020		
DIMENSIONS ARE IN IN.	THIRD ANGLE PROJECTION	TITLE: MDS-6EXTF/LPF PARTS BAG	
	PROPRIETARY AND CONFIDENTIAL	SUF: <b>A</b>	REV: <b>F</b>
	<small>THIS INFORMATION IS THE PROPERTY OF BENDPAK INC. IT IS TO BE USED ONLY FOR THE PURPOSES SPECIFIED HEREIN. IT IS NOT TO BE REPRODUCED OR TRANSMITTED IN ANY FORM OR BY ANY MEANS, ELECTRONIC OR MECHANICAL, INCLUDING PHOTOCOPYING, RECORDING, OR BY ANY INFORMATION STORAGE AND RETRIEVAL SYSTEM.</small>	DWG. NO.: 5174805	SCALE: 1:4
			SHEET 1 OF 1

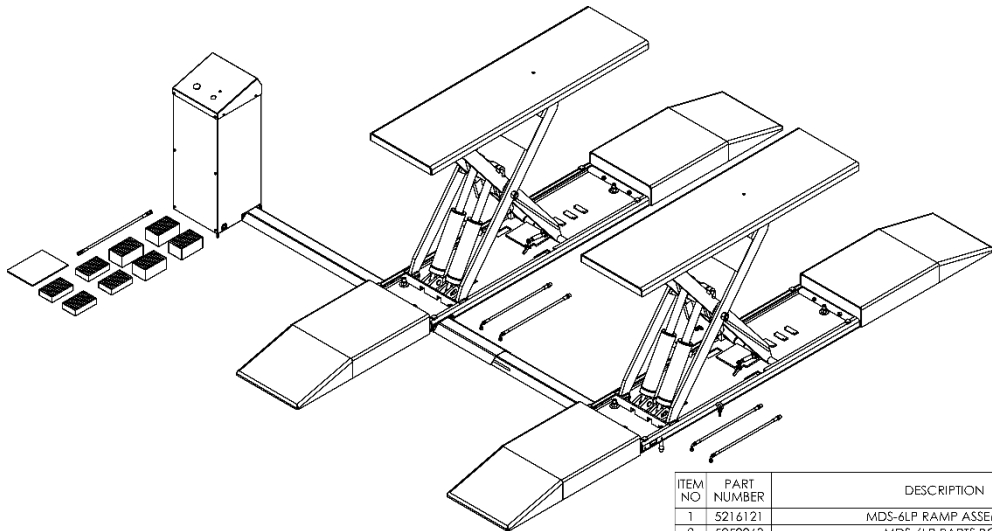

ITEM NO	PART NUMBER	DESCRIPTION	QTY	REV
1	5216121	MDS-6LP RAMP ASSEMBLY	2	A
2	5250063	MDS-6LP PARTS BOX	1	L
3	5601099	MDS-6/SP-7XE INNER FLOOR TROUGH WELDMENT	1	D
4	5601098	SP-7XE/MDS-6EXT/LP OUTER FLOOR TROUGH WELDMENT	1	C
5	5215780	SHORT POWER UNIT CONSOLE ASSEMBLY	1	G
6	5216081	MDS-6 APPROACH RAMP ASSEMBLY	4	A
7	5900030	MDS-6 INSTALLATION MANUAL	1	-
8	REF	POWER UNIT	1	-

DO NOT SCALE DRAWING		NAME	DATE	<b>BP BendPak</b> 1645 E-MONWOOD DR. SANTA PAULA, CA 93060
DRAWN	TM		03/09/2022	
DIMENSIONS ARE IN MM		CHECKED		TITLE: MDS-6LP PRODUCTION LIFT VER C
THIRD ANGLE PROJECTION				SIZE: DWG. NO. REV
		<small>PROPRIETARY AND CONFIDENTIAL FOR INFORMATION OF CUSTOMERS: THESE PARTS ARE THE PROPERTY OF BENDPAK INC. AND ARE NOT TO BE REPRODUCED OR USED FOR ANY OTHER PURPOSES WITHOUT THE WRITTEN PERMISSION OF BENDPAK INC. © 2022</small>		A 5260674 A
SCALE: 1:25			SHEET 1 OF 4	

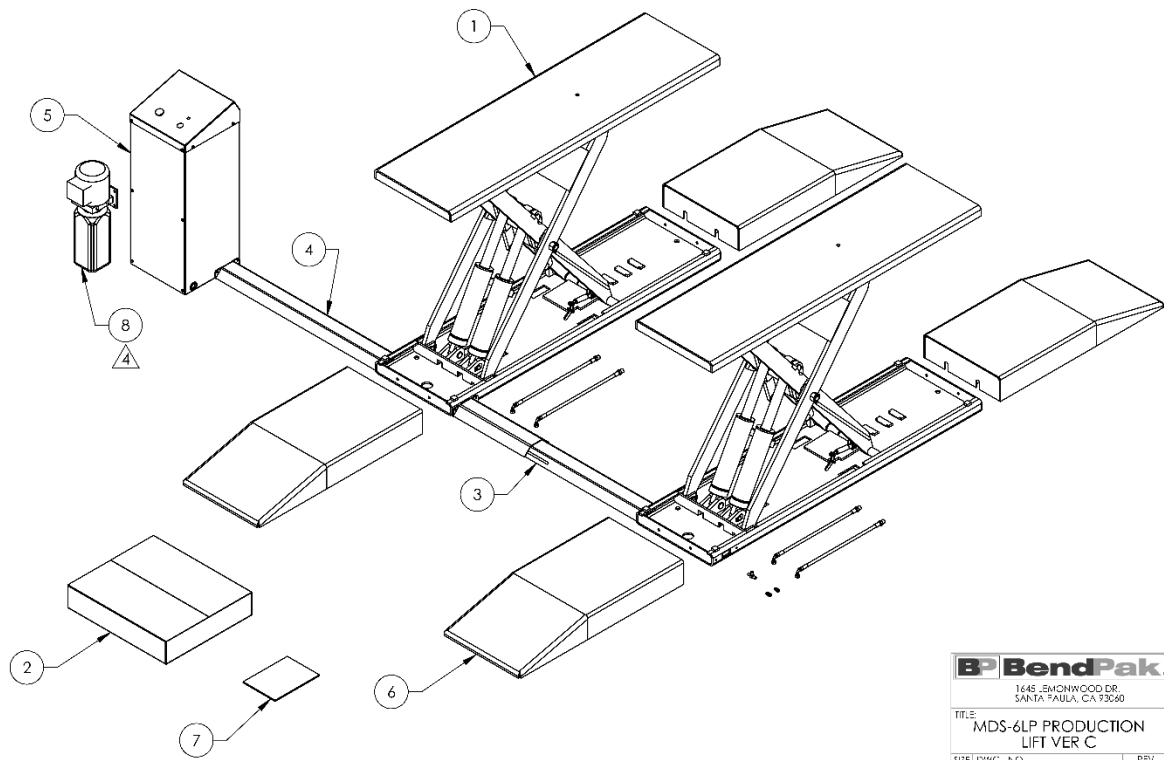

<b>BP BendPak</b>	
1645 E-MONWOOD DR. SANTA PAULA, CA 93060	
TITLE: MDS-6LP PRODUCTION LIFT VER C	
SIZE: DWG. NO.	REV
A 5260674	A
SCALE: 1:20	SHEET 2 OF 4

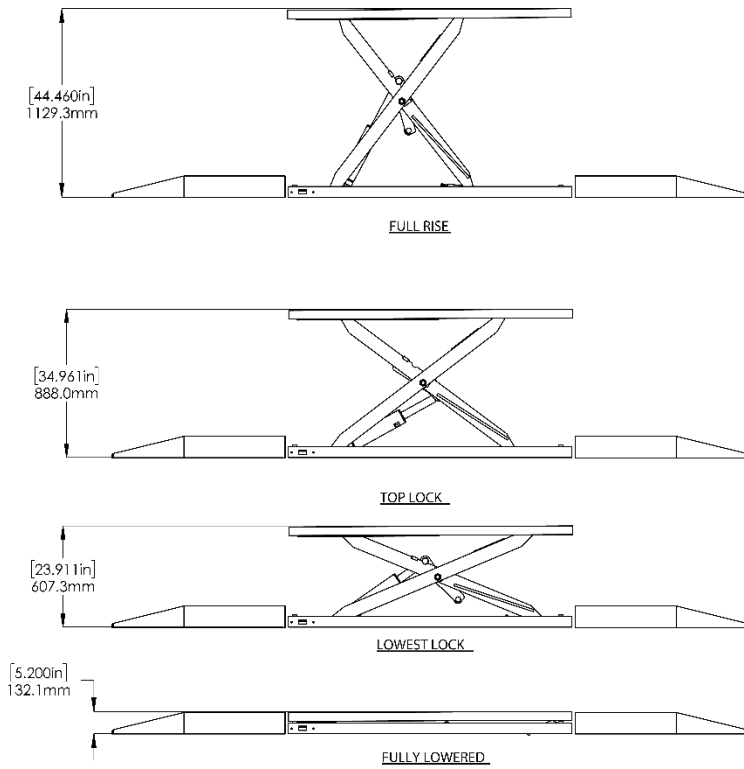

<b>BP BendPak</b>	
1445 LEMONWOOD DR. SANTA PAULA, CA 93060	
TITLE: MDS-6LP PRODUCTION LIFT VER C	
SUBJ: DWG. NO. A	REV: A
5260674	
SCALE: 1:25	SHEET 3 OF 4

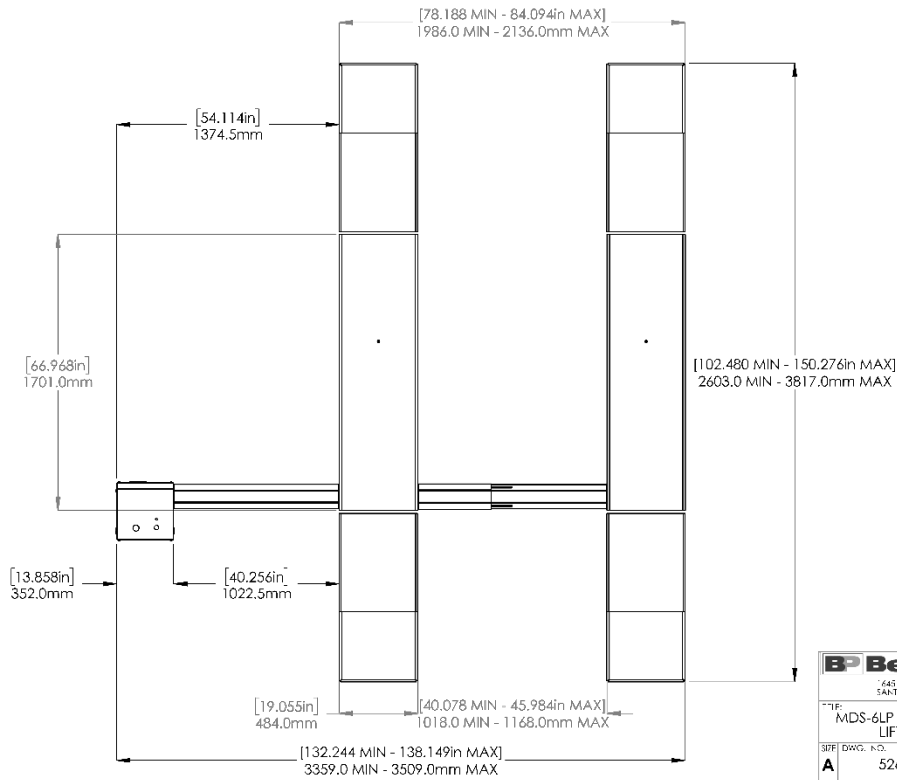

<b>BP BendPak</b>	
1445 LEMONWOOD DR. SANTA PAULA, CA 93060	
TITLE: MDS-6LP PRODUCTION LIFT VER C	
SUBJ: DWG. NO. A	REV: A
5260674	
SCALE: 1:25	SHEET 4 OF 4

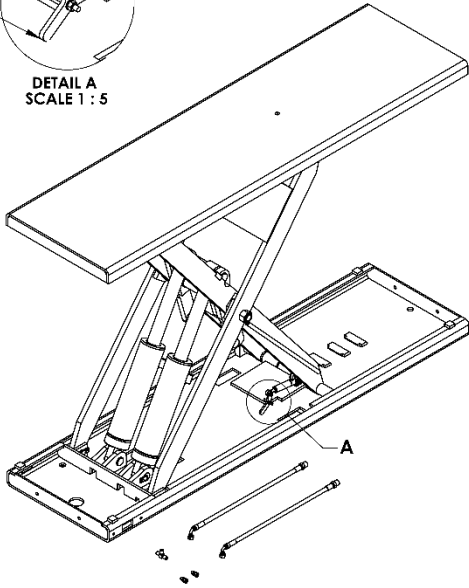
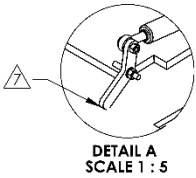

ITEM NO	PART NUMBER	DESCRIPTION	QTY	REV
1	5601796	MDS-6LP BASE WELDMENT	1	A
2	5601021	MDS-6 INNER SCISSOR WELDMENT	1	G
3	5600745	MDS-6 OUTER SCISSOR WELDMENT	1	J
4	5601531	MDS-6LP RAMP WELDMENT	1	A
5	5716202	MDS-6 SCISSOR BOTTOM SLIDE BLOCK 46mm	2	B
6	5716184	MDS-6 SCISSOR TOP SLIDE BLOCK 39mm	2	D
7	5746316	MDS-6 RAMP PIN	1	F
8	5601530	MDS-6 SCISSOR CLEVIS PIN WELDMENT	4	B
9	5535092	NUT M24 x 3.0 NL	2	--
10	5736890	MDS-6 SAFETY ROCKER ARM	1	B
11	5545005	WASHER, M6 x 12mm FLAT	2	--
12	5535357	NUT M6 x 1.0 NL	3	--
13	5502195	AIR CYLINDER, Ø19mm x 25 STROKE	1	--
14	5530093	HHB M6 x 1.0 x 20mm	1	--
15	5530757	HHB M6 x 1.0 x 40	1	--
16	5505625	FEMALE ROD END M6 x 33	1	--
17	5600747	MDS-6 CYLINDER GUIDE WELDMENT	1	E
18	5215475	MDS-6 SERIES CYLINDER GUIDE ARM ROLLER ASSEMBLY	2	B
19	5505136	SPRING PIN M5 x 40	2	--
20	5746431	BEARING SPACER, Ø44 x Ø30 x 2	2	A
21	5502031	CYLINDER ASSEMBLY Ø3.0 x 9"	2	J
22	5746700	MDS-6 SERIES CYLINDER GUIDE PIN, LARGE	1	C
23	5530374	SSS M8 x 1.25 x 16 EXTENDED NL	2	--
24	5756033	MDS-6 CYLINDER SEPARATOR	1	C
25	5570060	MDS-6 SERIES HYDRAULIC HOSE ASSY Ø6.35 x 254mm 5B	2	D
26	5550310	FTG TEE -04JIC -04JIC -04JIC	1	--
27	5550001	FTG NPL -04 COMP x -02 NPT	2	--
28	5550087	FTG ELB -04 COMP x -02 NPT	1	--
29	5545001	WASHER 25mm x 37mm	2	--
30	5530031	HHB M6 x 1.0 x 12mm	6	--

DO NOT SCALE DRAWING

NAME: IM DATE: 03/07/2022

1645 LEMCHWOOD DR.  
SANTA PAULA, CA 93060

BP BendPak

THIRD ANGLE PROJECTION

SMILES: JRP, NMV

THIRD ANGLE PROJECTION

TITLE: MDS-6LP RAMP ASSEMBLY

SIZE: DWG. NO. 5216121 REV A

SCALE: 1:15 SHEET 2 OF 2

7. 5736890 MUST ROTATE FREELY

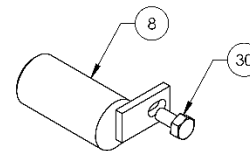
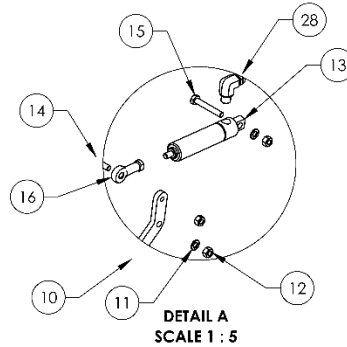
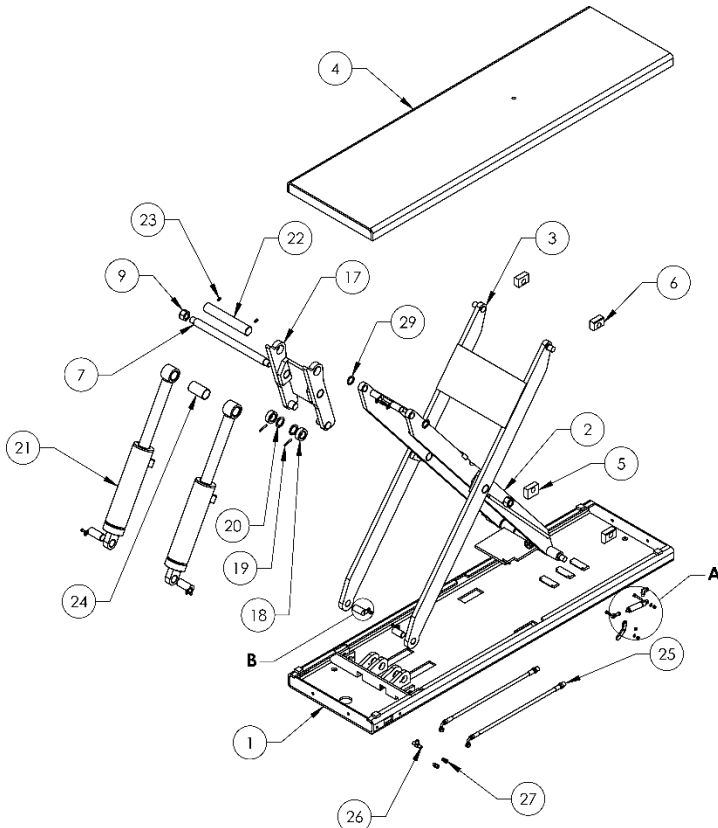

BP BendPak

1645 LEMCHWOOD DR.  
SANTA PAULA, CA 93060

TITLE: MDS-6LP RAMP ASSEMBLY

SIZE: DWG. NO. 5216121 REV A

SCALE: 1:18 SHEET 2 OF 2

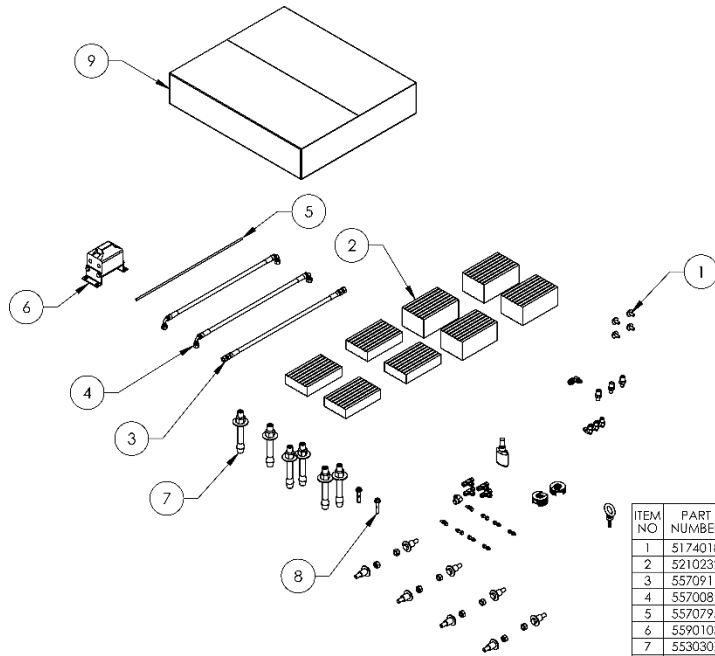

ITEM NO	PART NUMBER	DESCRIPTION	QTY	REV
1	5174018	MDS-6EXT/LP PARTS BAG	1	K
2	5210232	LOW RISE SCISSOR LIFT RUBBER PAD KIT, SET OF 8	1	A
3	5570911	MDS-6 SERIES HYDRAULIC HOSE ASSY Ø6.35 x 458mm DS	1	B
4	5570081	HYDRAULIC HOSE ASSEMBLY Ø6.35 x 3352mm DB	2	B
5	5570795	1/4" POLY-FLO TUBING	9260mm*	--
6	5590103	HYDRAULIC FLOW DIVIDER; MTE	1	--
7	5530307	AB 3/4" x 5"	6	--
8	5530326	AB Ø3/8" x 2-1/4"	2	--
9	5250063-1	MDS-6LP/LPF PARTS BOX	1	--

DRAWN		NAME	DATE	 1646 LEMONWOOD DR. SANTA PAULA, CA 93060
CHCKED	TM		01/30/2017	
DIMENSIONS ARE IN MM				TITLE: MDS-6LP PARTS BOX SM: DWG. NO. 5250063 REV L
THIRD ANGLE PROJECTION 				SCALE: 1:15 SHEET 1 OF 1

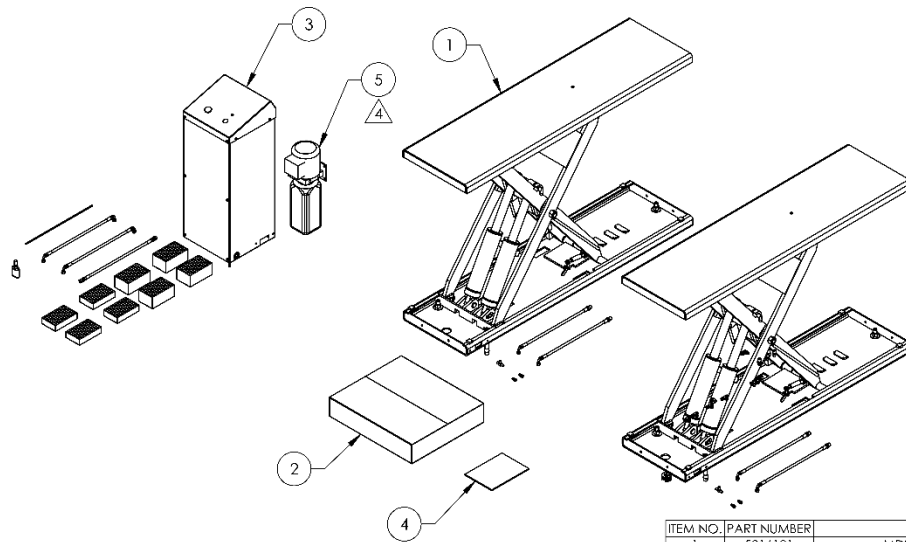

4. POWER UNIT REFERENCE ON PURCHASE ORDER

ITEM NO.	PART NUMBER	DESCRIPTION	QTY	REV
1	5216121	MDS-6LP RAMP ASSEMBLY	2	A
2	5250064	MDS-6LPF PARTS BOX	1	L
3	5215790	SHORT POWER UNIT CONSOLE ASSEMBLY	1	G
4	5900030	MDS-6 INSTALLATION MANUAL	1	D
5	REF	POWER UNIT	1	--

DRAWN		NAME	DATE	 1646 LEMONWOOD DR. SANTA PAULA, CA 93060
CHCKED	TM		03/09/2022	
DIMENSIONS ARE IN MM				TITLE: MDS-6LPF PRODUCTION LIFT VER C SM: DWG. NO. 5260673 REV A
THIRD ANGLE PROJECTION 				SCALE: 1:24 SHEET 1 OF 3

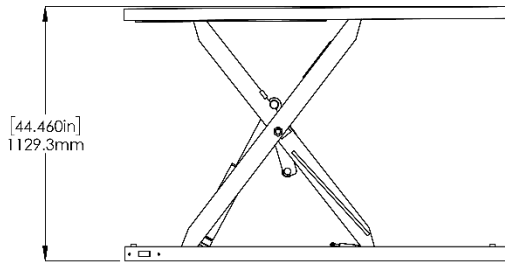

FULL RISE

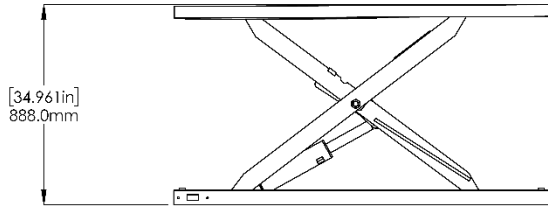

TOP LOCK

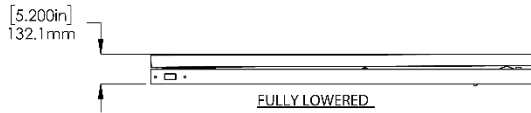

FULLY LOWERED

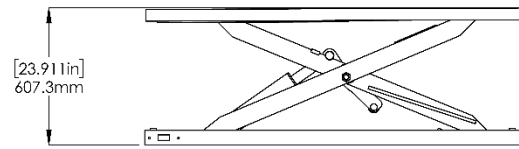

LOWEST LOCK

<b>BendPak</b>	
1645 SMOKEWOOD DR. SANTA PAULA, CA 93060	
TITLE: MDS-6LPF PRODUCTION LIFT VER C	
SIZE: DWG. NO.	REV
<b>A</b> 5260673	<b>A</b>
SCALE: 1:20	SHEET 2 OF 3

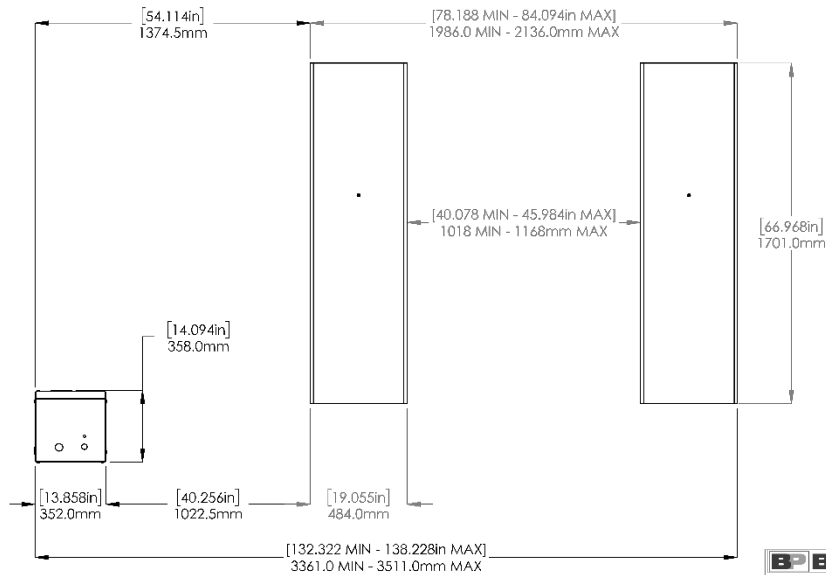

<b>BendPak</b>	
1645 SMOKEWOOD DR. SANTA PAULA, CA 93060	
TITLE: MDS-6LPF PRODUCTION LIFT VER C	
SIZE: DWG. NO.	REV
<b>A</b> 5260673	<b>A</b>
SCALE: 1:20	SHEET 3 OF 3

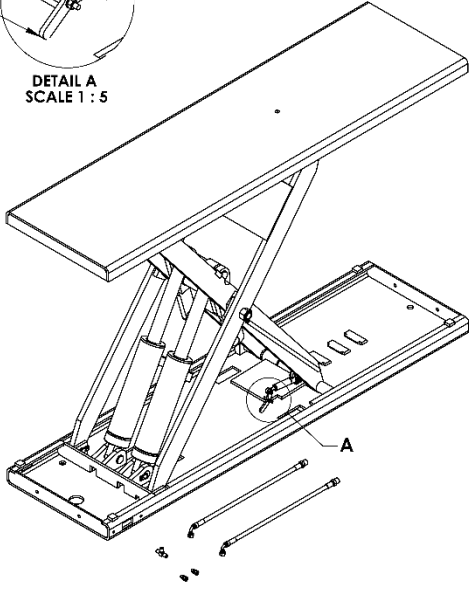
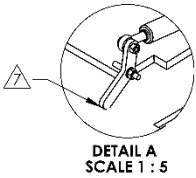

ITEM NO	PART NUMBER	DESCRIPTION	QTY	REV
1	5601796	MDS-6LP BASE WELDMENT	1	A
2	5601021	MDS-6 INNER SCISSOR WELDMENT	1	G
3	5600745	MDS-6 OUTER SCISSOR WELDMENT	1	J
4	5601531	MDS-6LP RAMP WELDMENT	1	A
5	5716202	MDS-6 SCISSOR BOTTOM SLIDE BLOCK 46mm	2	B
6	5716184	MDS-6 SCISSOR TOP SLIDE BLOCK 39mm	2	D
7	5746316	MDS-6 RAMP PIN	1	F
8	5601530	MDS-6 SCISSOR CLEVIS PIN WELDMENT	4	B
9	5535092	NUT M24 x 3.0 NL	2	--
10	5736890	MDS-6 SAFETY ROCKER ARM	1	B
11	5545005	WASHER, M6 x 12mm FLAT	2	--
12	5535357	NUT M6 x 1.0 NL	3	--
13	5502195	AIR CYLINDER, Ø19mm x 25 STROKE	1	--
14	5530093	HHB M6 x 1.0 x 20mm	1	--
15	5530757	HHB M6 x 1.0 x 40	1	--
16	5505625	FEMALE ROD END M6 x 33	1	--
17	5600747	MDS-6 CYLINDER GUIDE WELDMENT	1	E
18	5215475	MDS-6 SERIES CYLINDER GUIDE ARM ROLLER ASSEMBLY	2	B
19	5505136	SPRING PIN M5 x 40	2	--
20	5746431	BEARING SPACER, Ø44 x Ø30 x 2	2	A
21	5502031	CYLINDER ASSEMBLY Ø3.0 x 9"	2	J
22	5746700	MDS-6 SERIES CYLINDER GUIDE PIN, LARGE	1	C
23	5530374	SSS M8 x 1.25 x 16 EXTENDED NL	2	--
24	5756033	MDS-6 CYLINDER SEPARATOR	1	C
25	5570060	MDS-6 SERIES HYDRAULIC HOSE ASSY Ø6.35 x 254mm 5B	2	D
26	5550310	FTG TEE -04JIC -04JIC -04JIC	1	--
27	5550001	FTG NPL -04 COMP x -02 NPT	2	--
28	5550087	FTG ELB -04 COMP x -02 NPT	1	--
29	5545001	WASHER 25mm x 37mm	2	--
30	5530031	HHB M6 x 1.0 x 12mm	6	--

DO NOT SCALE DRAWING	NAME: IM	DATE: 03/07/2022	 1645 LEMCHWOOD DR. SANTA PAULA, CA 93060
	CHECKED: OR	03/21/2022	
SYMBOLS REF. NUM	THIRD ANGLE PROJECTION		TITLE: MDS-6LP RAMP ASSEMBLY
			SIZE: DWG. NO. A 5216121 REV A
<small>           PROPRIETARY AND CONFIDENTIAL            THE INFORMATION CONTAINED HEREIN IS THE PROPERTY OF BENDPAK INC. AND IS TO BE USED ONLY FOR THE PURPOSES SPECIFIED HEREIN.         </small>			SCALE: 1:15 SHEET 2 OF 2

5736890 MUST ROTATE FREELY

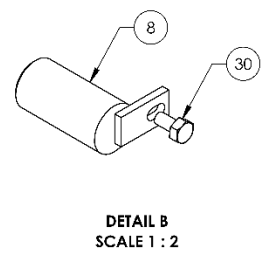
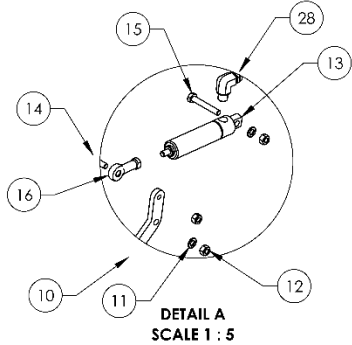
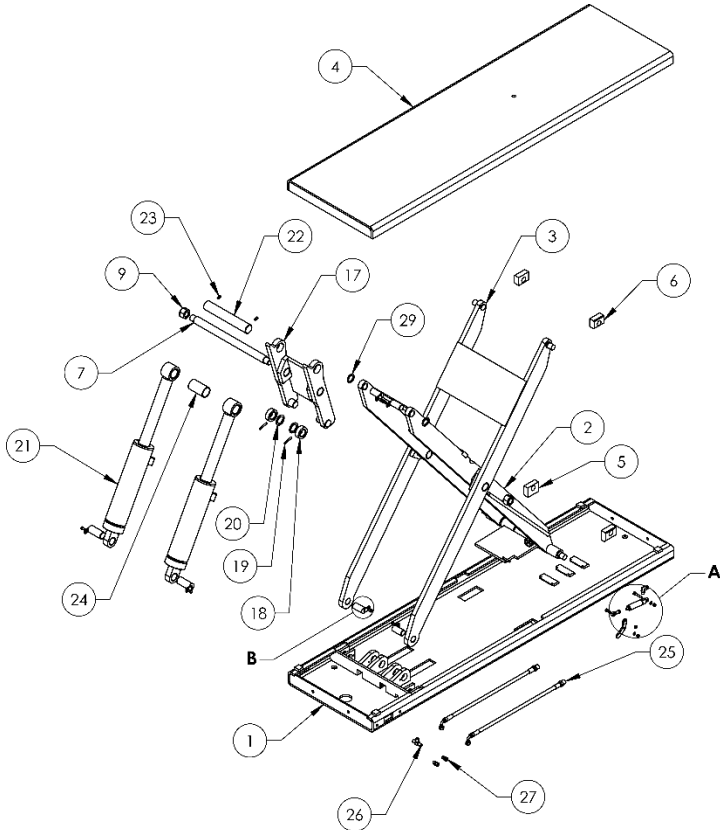

 1645 LEMCHWOOD DR. SANTA PAULA, CA 93060	
TITLE: MDS-6LP RAMP ASSEMBLY	
SIZE: DWG. NO. A 5216121	REV A
SCALE: 1:18 SHEET 2 OF 2	

# Automotive Lift Institute (ALI) Store

You probably checked the [ALI's Directory of Certified Lifts](http://www.autolift.org/ali-directory-of-certified-lifts/) (www.autolift.org/ali-directory-of-certified-lifts/) before making your most recent Lift purchase, but did you know the **ALI Store** (www.autolift.org/ali-store/) offers a wide variety of professional, easy-to-use, and reasonably priced training and safety materials that will make your garage a safer place to work?

*The ALI Store is your trusted source for workplace safety!*



**Lifting It Right Online Certificate Course.** Make *sure* you and your people are lifting vehicles the right way.



**ALI Lift Inspector Certification Program Registration.** Become a **ALI Certified Lift Inspector**.

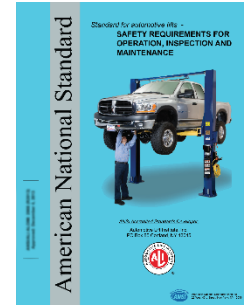

**ANSI/ALI ALOIM Standard for Automotive Lifts.** Safety Requirements for Operation, Inspection, and Maintenance.

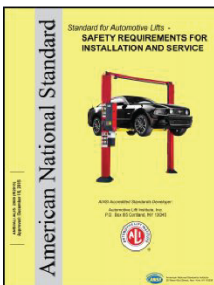

**ANSI/ALI ALIS Standard.** Safety Requirements for Installation and Service.



**Guide to Identifying Vehicle Lifting Points for Frame-Engaging Lifts.** Don't eyeball your lifting points, **know** where they are.



**Lift Operator Safety Materials.** Five safety documents in a single package.

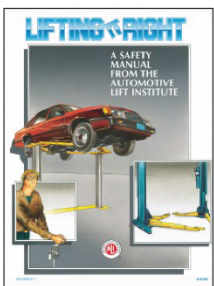

**Lifting It Right.** A hardcopy version of the *Lifting It Right* safety manual from the Automotive Lift Institute.

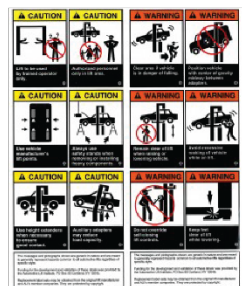

**Uniform Warning Labels and Placards for 2-Posts.** Labels in Mandarin, French Canadian, and Spanish are also available.



**Safety Tips Card.** Reminds your people of 13 key safety tips to follow daily.

**Visit today and get the training and materials you need to work safely:**  
[www.autolift.org/ali-store/](http://www.autolift.org/ali-store/).





