

litheli tool

Operating
Manual

U20 Cordless Inflator

SKU: U20IF00-0A110

Model No.: EPT130020

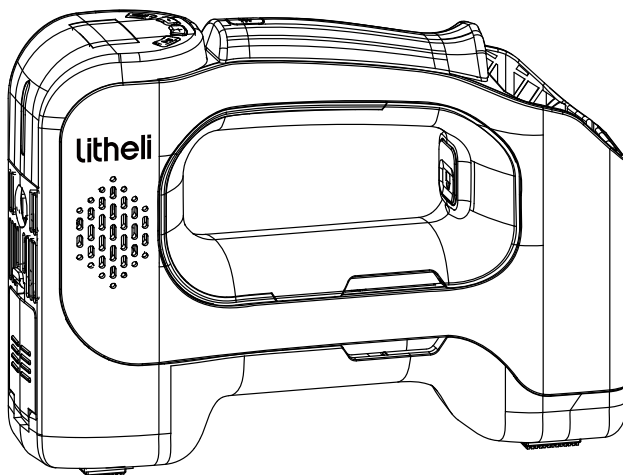

WARNING:

To reduce the risk of injury, the user must read and understand the user manual before using this product. Save this manual for future reference.

TABLE OF CONTENTS

Important Safety Instructions	02
Safety Symbols	10
Know Your Tool	13
Charging Your Battery	16
Operation	16
Maintenance	25
Troubleshooting	26
Warranty	27

READ ALL INSTRUCTIONS!



WARNING: Some dust created by power sanding, sawing, grinding, drilling and other construction activities contains chemicals known to the state of California to cause cancer, birth defects or other reproductive harm. Some examples of these chemicals are:

- Lead from lead-based paints,
- Crystalline silica from bricks and cement and other masonry products, and
- Arsenic and chromium from chemically-treated lumber.

Your risk from these exposures varies, depending on how often you do this type of work. To reduce your exposure to these chemicals: work in a well-ventilated area, and work with approved safety equipment, such as those dust masks that are specially designed to filter out microscopic particles.

Important Safety Instructions



WARNING:

Only use the accessories that are provided with this product or the accessories approved by Litheli. Using other accessories might increase the risk of injury. Follow the instructions in this manual to properly use the accessories.



WARNING:

This product can expose you to chemicals including lead and Di(2-ethylhexyl) phthalate (DEHP) which are known to the State of California to cause cancer and birth defects or other reproductive harm. For more information go to www.P65Warnings.ca.gov.

The appliance is only to be used with the power supply unit provided with the appliance.

GENERAL POWER TOOL SAFETY WARNINGS

WARNING:

Read all safety warnings, instructions, illustrations and specifications provided with this power tool. Failure to follow all instructions listed below may result in electric shock, fire and/or serious injury.

Save all warnings and instructions for future reference.

The term “power tool” in the warnings refers to your mains-operated (corded) power tool or battery-operated (cordless) power tool.

1.WORK AREA SAFETY

- a.Keep the work area clean and well-lit.** Cluttered or dark areas invite accidents.
- b.Do not operate power tools in explosive atmospheres, such as in the presence of flammable liquids, gases or dust.** Power tools create sparks that may ignite dust or fumes.
- c.Keep children and bystanders away while operating a power tool.** Distractions can cause you to lose control.

2.ELECTRICAL SAFETY

- a.Power tool plugs must match the outlet. Never modify the plug in any way. Do not use any adapter plugs with earthed (grounded) power tools.** Unmodified plugs and matching outlets will reduce the risk of electric shock.
- b.Avoid body contact with earthed or grounded surfaces, such as pipes, radiators, ranges and refrigerators.** There is an increased risk of electric shock if your body is earthed or grounded.
- c.Do not expose power tools to rain or wet conditions.** Water entering a power tool will increase the risk of electric shock.
- d.Do not abuse the cord. Never use the cord for carrying, pulling or unplugging the power tool. Keep the cord away from heat, oil, sharp edges or moving parts.** Damaged or entangled cords increase the risk of electric shock.
- e.When operating a power tool outdoors, use an extension cord suitable for outdoor use.** The use of a cord suitable for outdoor use reduces the risk of electric shock.
- f.If operating a power tool in a damp location is unavoidable, use a residual current device (RCD) protected supply.** The use of an RCD reduces the risk of electric shock.

3.PERSONAL SAFETY

- a.Stay alert, watch what you are doing and use common sense when operating a power tool. Do not use a power tool while you are tired or under the influence of drugs, alcohol or medication.** A moment of inattention while operating power tools may result in serious personal injury.
- b.Use personal protective equipment. Always wear eye protection.** Protective equipment such as dust masks, non-skid safety shoes, hard hats, or hearing protection used for appropriate conditions will reduce personal injuries.
- c.Prevent unintentional starting. Ensure the Trigger is in the off-position before connecting to the power source, picking up or carrying the tool.** Carrying power tools with your finger on the switch or energizing power tools that have the switch on invites accidents.
- d.Remove any adjusting key or wrench before turning the power tool on.** A wrench or a key left attached to a rotating part of the power tool may result in personal injury.
- e.Do not overreach. Keep proper footing and balance at all times.** This enables better control of the power tool in unexpected situations.
- f.Dress properly. Do not wear loose clothing or jewelry. Keep your hair and clothing away from moving parts.** Loose clothes, jewelry or long hair can be caught in moving parts.
- g.If devices are provided for the connection of dust extraction and collection facilities, ensure these are connected and properly used.** The use of dust collection can reduce dust-related hazards.
- h.Do not let familiarity gained from the frequent use of tools allow you to become complacent and ignore tool safety principles.** A careless action can cause severe injury within a fraction of a second.

4.POWER TOOL USE AND CARE

- a.Do not force the power tool. Use the correct power tool for your application.** The correct power tool will do the job better and safer at the rate for which it was designed.
- b.Do not use the power tool if it cannot be turned on/off by the switch.** Any power tool that cannot be controlled with the switch is dangerous and must be repaired.
- c.Disconnect the plug from the power source and/or remove the battery pack, if detachable, from the power tool before making any adjustments, changing accessories, or storing power tools.** Such preventive safety measures reduce the risk of starting the power tool accidentally.

- d.Store idle power tools out of the reach of children and do not allow persons unfamiliar with the power tool or these instructions to operate the power tool.** Power tools are dangerous in the hands of untrained users.
- e.Maintain power tools and accessories. Check for misalignment or binding of moving parts, breakage of parts and any other condition that may affect the power tool's operation. If damaged, have the power tool repaired before use.** Many accidents are caused by poorly maintained power tools.
- f.Keep cutting tools sharp and clean.** Properly maintained cutting tools with sharp cutting edges are less likely to bind and are easier to control.
- g.Use the power tool, accessories and tool bits, etc. in accordance with these instructions, taking into account the working conditions and the work to be performed.** Use of the power tool for operations different from those intended could result in a hazardous situation.
- h.Keep handles and grasping surfaces dry, clean and free from oil and grease.** Slippery handles and grasping surfaces do not allow for safe handling and control of the tool in unexpected situations.

5.BATTERY TOOL USE AND CARE

- a.Recharge only with the charger specified by the manufacturer.** A charger that is suitable for one type of battery pack may create a risk of fire when used with another battery pack.
- b.Use power tools only with specifically designated battery packs.** Use of any other battery packs may create a risk of injury and fire.
- c.When the battery pack is not in use, keep it away from other metal objects, like paper clips, coins, keys, nails, screws or other small metal objects, that can make a connection from one terminal to another.** Short-circuiting the battery terminals together may cause burns or a fire.
- d.Under abusive conditions, liquid may be ejected from the battery; avoid contact. If contact accidentally occurs, flush with water. If liquid contacts the eyes, additionally seek medical help.** Liquid ejected from the battery may cause irritation or burns.
- e.Do not use a battery pack or tool that is damaged or modified.** Damaged or modified batteries may exhibit unpredictable behavior resulting in fire, explosion or risk of injury.
- f.Do not expose a battery pack or tool to fire or excessive temperature.** Exposure to fire or temperature above 130 °C may cause an explosion.

g. Follow all charging instructions and do not charge the battery pack or tool outside the temperature range specified in the instructions. Charging improperly or at temperatures outside the specified range may damage the battery and increase the risk of fire.

6. Service

- a. Have your power tool serviced by a qualified repair person using only identical replacement parts.** This will ensure that the safety of the power tool is maintained.
- b. Never service damaged battery packs.** Service of battery packs should only be performed by the manufacturer or authorized service providers.

INFLATOR USE AND CARE

1. Check hoses for weak or worn conditions before each use, making certain all connections are secure. Do not use it if any defect is found. Purchase a new hose or notify an authorized service center for examination or repair.
2. Release all pressures within the system slowly. Dust and debris may be harmful.
3. Do not use an inflator if Power Button does not turn on or off. An inflator that cannot be controlled with the Power Button is dangerous and must be repaired.
4. Place the Power Button in the off position and remove the battery pack before making any adjustments, changing accessories, or storing the inflator. Such preventive safety measures reduce the risk of starting the inflator accidentally.
5. Store idle inflators out of reach of children and other untrained persons. Inflators are dangerous in the hands of untrained users.
6. Check for misalignment or binding of moving parts, breakage of parts, and any other condition that may affect the inflator's operation. If damaged, have the inflator serviced before use. Many accidents are caused by poorly maintained tools.
7. Use only accessories that are recommended by the manufacturer for your model. Accessories that may be suitable for one inflator may create a risk of injury when used on another inflator.
8. Keep the inflator and its handle dry, clean and free from oil and grease. Always use a clean cloth when cleaning. Never use brake fluids, gasoline, petroleum-based products, or any strong solvents to clean your inflator. Following this rule will reduce the risk of loss of control and deterioration of the enclosure plastic.

9. Never point any inflator toward yourself or others.
10. Do not exceed the pressure rating of any component in the system.
11. Protect material lines and air lines from damage or puncture. Keep hose and power cord away from sharp objects, chemical spills, oil, solvents, and wet floors.

SAFETY WARNINGS FOR INFLATOR

1. Know your inflator. Read the operator's manual carefully. Learn its applications and limitations, as well as the specific potential hazards related to this tool. Following this rule will reduce the risk of electric shock, fire, or serious injury.
2. Risk of bursting. Do not operate inflator to result in output pressure greater than the marked maximum pressure of the item to be inflated. Otherwise, the tool or object may be damaged and you may be injured. Do not use at a pressure greater than 150 PSI.
3. To reduce the risk of electric shock, do not be exposed to rain. Store indoors.
4. Make sure the hose is free of obstructions or snags. Entangled or snarled hoses can cause loss of balance or footing and may become damaged.
5. Inflate the objects intended to be inflated by the manufacturer only, such as tires, sports balls, or small floating tubes. Inflating other objects may damage them and cause an injury. Do not alter or modify the unit from the original design or function.
6. Do not continue to use an inflator or hose that leaks air or does not function properly.
7. Always disconnect the air supply and power supply before making adjustments, servicing an inflator, or when an inflator is not in use.
8. When carrying the tool, hold the handle of the tool. Do not hold or pull the hose. The tool may be damaged and cause an injury.
9. Household use only.
10. Do not use an inflator as a breathing device.
11. Never direct a jet of compressed air toward people or animals. Take care not to blow dust and dirt towards yourself or others. Following this rule will reduce the risk of serious injury.
12. Protect your lungs. Wear a face or dust mask if the operation is dusty. Following this rule will reduce the risk of serious personal injury.
13. Do not use this inflator to spray chemicals. Your lungs can be damaged by inhaling toxic fumes.

14. Check damaged parts. Before further use of the inflator or air tool, a guard or other part that is damaged should be carefully checked to determine that it will operate properly and perform its intended function. Check for alignment of moving parts, binding of moving parts, breakage of parts, mounting, and any other conditions that may affect its operation. A guard or other part that is damaged should be properly repaired or replaced by an authorized service center. Following this rule will reduce the risk of shock, fire, or serious injury.
15. To reduce the risk of over inflation, use a reliable pressure gauge periodically during inflation. The pressure gauge on the inflator is for reference only and is therefore not binding for exact values.
16. Never leave the tool unattended when the hose is attached to the object or during operation.
17. Allow pump to cool for five (5) minutes after each five (5) minutes of continuous use. Never block the inflating or deflating outlets while operating.
18. Do not use the tool in locations where the temperature may go -10°C (14°F) or less, or 40°C (104°F) or more.
19. When folding the clamp of air chuck, be careful not to pinch your fingers between the air chuck and clamp.
20. Operate the tool in an open area at least 50cm (20") away from any wall or object that could restrict airflow to ventilation openings.
21. Do not use the tool on sand or dusty surfaces. Foreign objects may enter the inside of the tool and cause a malfunction.
22. Release air pressure slowly. When removing the hose after inflating objects, hold the object, hose, and air chuck firmly. The object, air chuck, or adapter may bounce due to exhaust air and cause an injury.
23. Do not disassemble the tool.
24. Do not touch the tool, hose, air chuck, or adapter right after inflating objects. The metal parts may become extremely hot and could burn your skin.
25. Do not inflate large-capacity objects. If you inflate a large-capacity object, the tool may become extremely hot and could burn your skin.
26. When inflating objects, check the pressure gauge, status of the tool and object, and check that there is no air leak. Otherwise, the tool or object may be damaged and cause an injury.
27. Do not use the tool beyond the maximum output pressure of the tool. Using the tool at an output pressure greater than the maximum output pressure of the tool may burst the object or the tool.

SAFETY WARNINGS FOR BATTERY PACK

1. Do not modify or attempt to repair the battery pack. Do not dismantle, open or shred battery pack.
2. Do not expose a battery pack or appliance to fire or excessive temperature. Exposure to fire or temperature above 265°F (130°C) may cause explosions.
3. Do not short-circuit a battery pack. Do not store battery packs haphazardly in a box or drawer where they may short-circuit each other or be short-circuited by other metal objects. When battery pack is not in use, keep it away from other metal objects, like paper clips, coins, keys, nails, screws or other small metal objects, that can make a connection from one terminal to another. Shorting the battery terminals together may cause burns or fire.
4. Do not subject battery pack to mechanical shock.
5. Observe the plus (+) and minus (-) marks on the battery back and equipment and ensure correct use.
6. Keep battery pack out of the reach of children.
7. Always purchase the battery pack recommended by the device manufacturer for the equipment.
8. Keep battery pack clean and dry.
9. Wipe the battery pack terminals with a clean dry cloth if they become dirty.
10. Battery pack need to be charged before use. Always use the correct charger and refer to the manufacturer's instructions or equipment manual for proper charging instructions.
11. Do not leave battery pack on prolonged charge when not in use.
12. After extended periods of storage, it may be necessary to charge and discharge the battery pack several times to obtain maximum performance.
13. Battery pack gives its best performance when it is operated at normal room temperature (20 °C ± 5 °C).
14. Use only the battery pack in the application for which it was intended. Do not use a battery pack or appliance that is damaged or modified. Damaged or modified batteries may exhibit unpredictable behavior resulting in fire, explosion or risk of injury.
15. Remove the battery pack from the equipment when not in use.
16. Dispose of properly.
17. Do not handle the charger, including charger plug, or charger terminals with wet hands.
18. Do not charge the battery pack outdoors, in rain, or in wet locations.
19. Recharge only with the charger specified by the manufacturer. A charger that is suitable for one type of battery pack may create a risk of fire when used with another battery pack.

20. Use power tools only with specifically designated battery packs. Use of any other battery packs may create a risk of injury and fire.
21. Under abusive conditions, liquid may be ejected from the battery; avoid contact. If contact accidentally occurs, flush with water. If liquid contacts eyes, additionally seek medical help. Liquid ejected from the battery may cause irritation or burns.

Save these instructions. Refer to them frequently and use them to instruct others who may use this tool. If you lend this tool to someone else, also lend these instructions to them to prevent misuse of the product and possible injury.

SERVICE

Have your power tool serviced by a qualified repair person using only identical replacement parts. This will ensure that the safety of the power tool is maintained.



Never service damaged battery packs. Service of battery packs should only be performed by the manufacturer or authorized service providers.

Save these instructions. Refer to them frequently and use them to instruct others who may use this tool. If you lend this tool to someone else, also lend these instructions to them to prevent misuse of the product and possible injury.









Safety Symbols

The purpose of safety symbols is to attract your attention to possible dangers. The safety symbols and the explanations with them deserve your careful attention and understanding. The symbol warnings do not, by themselves, eliminate any danger. The instructions and warnings they give are not substitutes for proper accident prevention measures.

The following signal words and meanings are intended to explain the levels of risk associated with this product.

SYMBOL	SIGNAL	MEANING
	DANGER	Indicates a hazardous situation, which, if not avoided, will result in death or serious injury.
	WARNING	Indicates a hazardous situation, which, if not avoided, will result in death or serious injury.
	CAUTION	Indicates a hazardous situation, which, if not avoided, may result in death or serious injury.
	NOTICE	(Without Safety Alert Symbol) Indicates information considered important, but not related to a potential injury (e.g. messages relating to property damage).

Some of the following symbols may be used on this product. Please study them and learn their meaning. Proper interpretation of these symbols will allow you to operate the product better and safer.

Symbol	Description	Symbol	Description
	To reduce the risk of injury, user must read instruction manual.		Do not expose to rain.
	WARNING		Wear ear protection.
	Open flames in the work area, around the product and in the vicinity of flammable materials are prohibited!		Do not burn the battery pack.
	Batteries may enter water cycle if disposed of improperly, which can be hazardous to the ecosystem. Do not dispose of old batteries as unsorted municipal waste.	 Li-Ion 	Li-Ion battery. This product has been marked with a symbol relating to a 'separate collection' for all battery packs. It will then be recycled or dismantled to reduce the impact on the environment. Battery packs can be hazardous to the environment and human health since they contain hazardous substances.

Know Your Tool

1. Worklight / SOS Emergency Light
2. Worklight Button
3. Soft Grip
4. Air Chuck Clamp
5. Air Chuck
6. Air Hose
7. Hose Clamp
8. Power Button (Start/Stop Button)
9. Mode Switch Button
10. Decrease PSI
11. Increase PSI
12. Display Screen
13. Battery Power Indicator Light
14. Battery Power Button
15. Two-Way Type-C Port
16. USB-A Port
17. Charging Cable
18. Tapered Adapter
19. Sports Ball Needle
20. Presta Valve Adapter

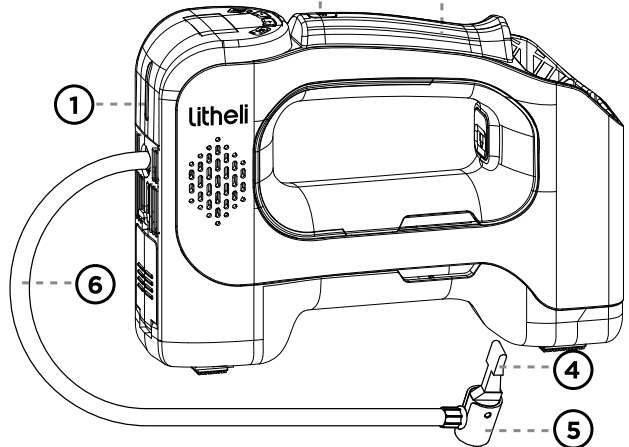
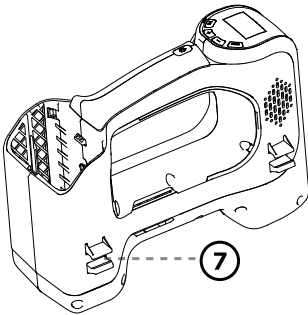
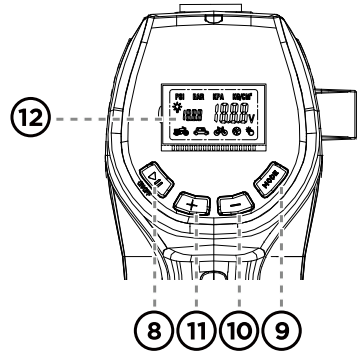
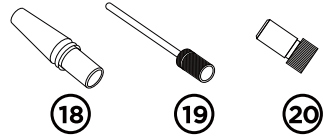

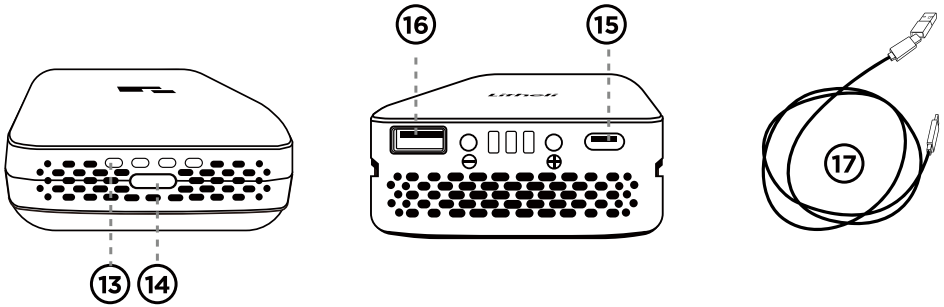

Technical Data

SKU No.	U20IF00-0A110
Model No.	EPT130020
Voltage	20V
Max. Pressure	150PSI
Flow Rate	6.6Gallon/min; 25L/min
Pressure Units	PSI, BAR, KPA, KG/CM ²
Siphon Hose Length	23.6" (600mm)
Dimensions	9.1" *6.7" *4" (232*169*102mm)
Machine Weight (Battery Excluded)	2.65lbs (1.2kg)

Accessories

Part Name	QUANTITY
Tapered Adapter	1
Sports Ball Needle	1
Presta Valve Adapter	1
Battery	1
Charging Cable	1
Operator's Manual	1

Litheli BATTERY (U-BATTERY PLUS)

NOTICE:

- Use only Litheli U-Battery Plus for this appliance.
- This Litheli U-Battery Plus is not resistant to water or dust. Please always keep this battery dry and clean when in use and storage. Do not allow water or moisture to enter this battery.

- Benefiting from the innovative battery replacement design, the battery can be exchanged easily.
- Short charging time, and minimal heating while charging.
- The same lithium-ion electrochemistry which is for new energy vehicles.
- Can work as power bank and charge mobile phones and laptops.

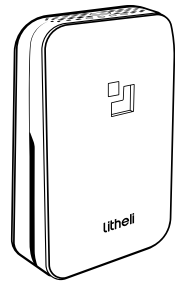

CHARGING YOUR BATTERY

WARNING:

Charge the battery in a dry and ventilated room, far away from combustibles and ignition sources.

NOTICE: The charger is not supplied with this appliance. You should prepare a charger to work with the supplied charging cable for charging. Make sure the charger meets the charging requirements of the battery pack. If you have any questions, please contact Litheli Customer Service for assistance.

NOTICE: Lithium-ion batteries are shipped partially charged. Before using it for the first time, fully charge the battery.

NOTICE: Please refer to the Charging Your Battery section of the battery pack manual for details of the indicated lights display and charging considerations.

OPERATION

WARNING:

To reduce the risk of fire, personal injury, and product damage due to a short circuit, never immerse your tool or battery pack in fluid or allow fluid to flow inside it. Corrosive or conductive fluids, such as seawater, certain industrial chemicals, and bleach or bleach-containing products, etc., can cause a short circuit.

WARNING:

If any parts are damaged or missing, do not operate this product until the parts are replaced. Use of this product with damaged or missing parts could result in serious personal injury.

WARNING:

Do not attempt to modify this product or create accessories not recommended for use with this inflator. Any such alteration or modification is misuse and could result in a hazardous condition leading to possibly serious personal injury.

WARNING:

Always remove the battery pack from the product when you are assembling parts, making adjustments, cleaning, or when the product is not in use.

TO INSTALL/REMOVE BATTERY PACK (Fig.1)

Be careful not to turn on the tool when attaching the battery pack.

To install the battery pack

Align the raised rib on the battery pack with the grooves in the tool, and then slide the battery pack onto the tool.

To remove the battery pack

Depress the battery-release button to release the battery pack. Pull the battery pack out and remove it from the tool.

NOTICE: When placing the battery pack on the tool, be sure that the raised rib on the battery pack aligns with the groove inside the tool and that the latches snap into place properly. Improper attachment of the battery pack can cause damage to internal components.

WARNING:

Battery tools are always in operating condition. Be careful when the tool is not in use or when carrying it on your side.

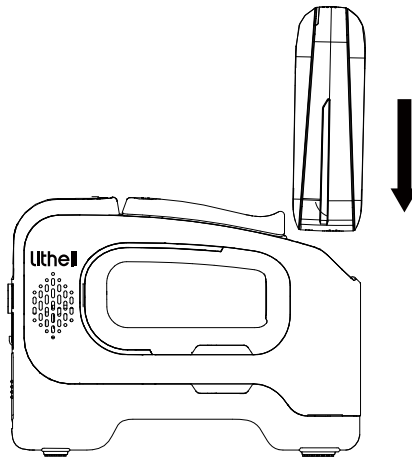

Fig. 1

Turn on/off the Digital Gauge (Fig.2)

⚠️ WARNING:

Since the pressure gauge is not calibrated, and is therefore not binding for exact values, tire pressure must be checked using a reliable measuring device before driving a vehicle with vehicle tires inflated with the inflator. Driving a vehicle with improperly inflated tires could result in serious injury.

1. Long press the Power Button to turn on the tool and hold the Button to turn it off.

NOTICE: To avoid accidental activation, the tool will automatically shut down if no activity is detected within 1 minutes of its activation.

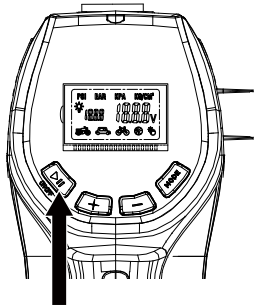

Fig. 2

Intelligent Inflation Mode Switching (Fig.3)

The tool is equipped with an Intelligent Inflation Mode, offering versatile functionality to suit your specific inflation needs. This mode includes four distinct presets for inflating various types of items: motorcycle tires, automobile tires, bicycle tires, and basketballs.

1. Long press the Mode Switch Button to switch between these modes and the LED display will indicate the currently selected mode.

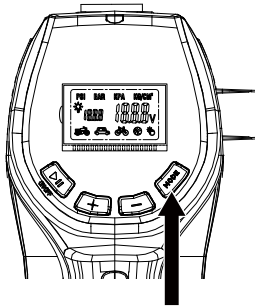

Fig. 3

Inflation Units Switching (Fig.4-5)

1. The inflator offers four pressure units (Psi, Bar, Kpa, and Kg/cm²). Short press the Mode Switch Button to switch between them and the selected unit appears on the LED screen.

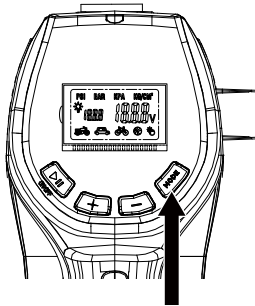

Fig. 4

2. To adjust the inflation pressure as needed, short press the INCREASE PSI or DECREASE PSI button. The air pump will automatically remember the set pressure value.

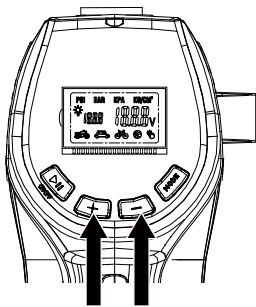

Fig. 5

NOTICE: The digital gauge on the inflator is multifunctional. It can serve as a pressure gauge and monitor the amount of pressure being applied to the item being inflated.

NOTICE: Object's original air pressure will be displayed once connected. Without connection, "0" will be displayed.

NOTICE: Always check and follow the manufacturer's recommended pressure.

NOTICE: The inflator is capable of inflating to 150 PSI. To avoid over inflation, carefully follow instructions on items to be inflated. To avoid product damage, never exceed recommended pressures.

TO START/STOP THE INFLATOR

To start the inflator

When the desired setting has been selected, short press the Power Button to start the inflator.

⚠️ WARNING:

Do not leave items to be inflated unattended while inflator is in use. These items can burst and could cause serious injury.

NOTICE: The inflator is not designed for continuous use. For every five minutes of inflator use, five minutes of cool-down time is required.

To stop the inflator

To turn the inflator OFF, short press the Power Button to stop the inflator. Long press the Power Button to turn the DIGITAL GAUGE off.

USING THE SCHRADER VALVE ADAPTER

The air chuck on the air hose can be used without adapters to inflate tires or with any item with a valve stem that fits the air chuck opening.

1. Install the battery pack.
2. Position air chuck clamp in the unlock position perpendicular to the air hose.
3. Place the air chuck on the valve stem.
4. Push the air chuck down so that the threaded section of the valve stem is inside the air chuck.
5. Clamp the end of the air chuck down onto the valve stem by pressing air chuck clamp down until it stops or is parallel with the air hose.
6. Long press the power button to turn on the digital gauge, then short press the button to start the inflator.

NOTICE: The pressure readout on the gauge while inflating is a measurement of the fluctuating pressure between the item and the air hose. To get an accurate reading, release the switch trigger and wait for the readout to adjust.

7. The gauge will indicate the pressure in PSI. When the desired pressure is reached, release the switch trigger and disconnect the inflator.

NOTICE: Always leave the hose free of obstructions when the tool is not in use. Overheating could occur if the hose is blocked.

Inflating with the Air Hose and Adapters (Fig.6)

The air hose can be used with the provided adapters to inflate a variety of items.

Insert adapter into air chuck and push air clamp down until it locks into place (Fig. 6).

2. To remove, lift air chuck clamp and remove adapter from air chuck (Fig. 6).

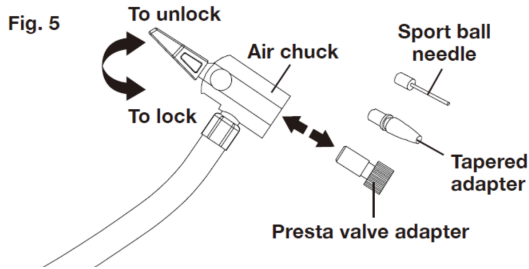
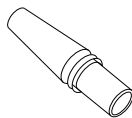

Fig. 6

Adapter Functions (Fig. 7)

- The tapered adapter can be used on smaller air valves to inflate items like floats and children's toys, which usually require the user to inflate them by blowing air into them.
- The sports ball needle can be used to inflate any type of sports ball or any other item that requires a sports ball needle.
- The Presta valve adapter can be used to inflate Presta valve stem tires as shown. Before inflating a tire with a Presta valve, loosen the locking nut to inflate. Once inflation is complete, tighten the locking nut to seal the tire valve.



Tapered
adapter

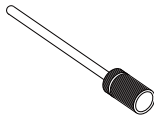

Sport ball
needle



Presta valve
adapter

Fig. 7

To use the Presta valve adapter:

1. Loosen Presta valve locking nut (Fig. 8).

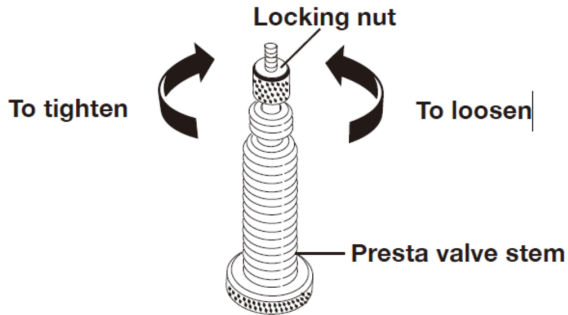

Fig. 8

1. Thread Presta valve adapter onto valve stem with a larger open end toward wheel (Fig. 9).
3. Clamp the end of the air chuck down onto the Presta valve adapter by pressing air chuck clamp down until it locks into place (Fig. 9).
4. After inflation, remove air chuck and tighten locking nut (Fig. 8).

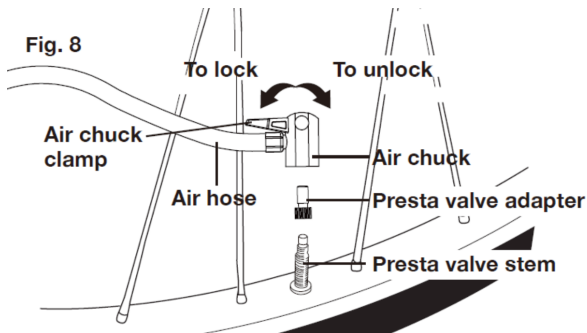

Fig. 9

To use the Sports Ball Needle or Tapered Adapter (Fig.10-11)

1. Unfold the air chuck clamp.
2. Attach the sports ball needle or tapered adapter to the air chuck.
3. Fold the air chuck clamp firmly.
4. Insert the sports ball needle or tapered adapter into the hole on the item and inflate.
5. After inflation, remove sports ball needle or tapered adapter.

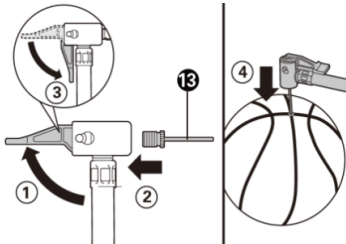

Fig. 10

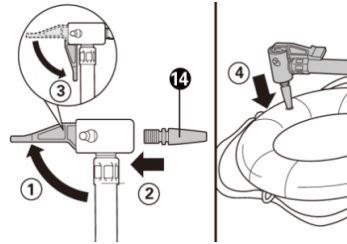

Fig. 11

NOTICE: When inflating a floating tube, the pressure gauge will not display an accurate value since the pressure of floating tube is less than 20KPA (3PSI). When inflating a floating tube, do not use the value on the pressure gauge, but inflate it by checking the status of the floating tube.

LED WORKLIGHT / SOS emergency light (Fig.12)

Your tool is equipped with an LED worklight / SOS emergency light, located in the front of the tool. Press the worklight button to cycle through the worklight or SOS emergency light.

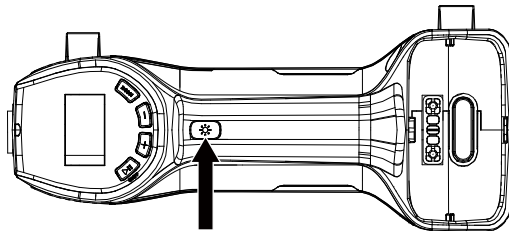

Fig. 12

MAINTENANCE

WARNING:

To avoid serious personal injury, always remove the battery pack from the tool when cleaning or performing any maintenance.

SERVICE

WARNING:

Preventive maintenance performed by unauthorized personnel may result in misplacing of internal wires and components which could cause serious hazards.

We recommend that all tool services be performed by Litheli Customer Service.

GENERAL MAINTENANCE

WARNING:

When servicing, use only identical replacement parts. Use of any other parts could create a hazard or cause product damage.

Periodically inspect the entire product for damaged, missing, or loose parts such as screws, nuts, bolts, caps, etc. Securely tighten all fasteners and caps and do not operate this product until all missing or damaged parts are replaced. Please contact Litheli Customer Service for assistance.

CLEANING THE INFLATOR

Avoid using solvents when cleaning plastic parts. Most plastics are susceptible to damage from various types of commercial solvents and may be damaged by their use. Use clean cloths to remove dirt, dust, oil, grease, etc.

WARNING:

Do not at any time let brake fluids, gasoline, petroleum-based products, penetrating oils, etc., come in contact with plastic parts. Chemicals can damage, weaken or destroy plastic which could result in serious personal injury.

STORING THE INFLATOR

Store the tool indoors in a place that is inaccessible to children. Keep away from corrosive agents.

STORING THE BATTERY PACK

- a. Protect the battery against moisture and water.
- b. Store the battery only within a temperature range from 40°F to 104°F. As an example, do not leave the battery in a vehicle or in the inflator in direct sunlight.
- c. Clean the ventilation slots of the battery occasionally with a soft, clean and dry brush. A considerably shortened operating time after charging is an indication that the battery is exhausted and must be replaced.
- d. If you do not use the product for a long time, please charge and discharge the battery pack once every 6 months.

Troubleshooting

 **WARNING:**
Turn off the tool and remove the battery pack prior to any troubleshooting.

Problem	Possible causes	Remedy
Tool will not start.	Battery pack is depleted.	Charge the battery pack.
	Battery pack is not installed properly.	Confirm battery pack is locked and secured to the tool.
	Burned out switch.	Contact Litheli Customer Service.
Overheating.	Force tool to work too fast.	Allow tool to work at its own rate.
	Blocked motor housing vents.	Using vacuum to clean debris from Air Intake vents.

No pressure.	Adapter is not connected well.	Check the adapter and make sure it is well fitted.
	Adapter is blocked.	Clean the adapter.
	Wrong Adapter is used.	Make sure you are using the correct adapter.

Environmental Protection



Waste electrical products must not be disposed of with household waste. Please recycle where facilities exist. Check with your local authorities or retailer for recycling advice.

WARRANTY

Litheli WARRANTY POLICY FOR U20 PRODUCT

- 3-year limited warranty on Litheli outdoor power equipment and power tools for personal, household use.
- 1-year limited warranty on Litheli battery packs and chargers for personal, household use.

Please contact Litheli Customer Service at service@litheli.com any time you have questions or warranty claims.

LIMITED WARRANTY SERVICE

FOR THREE YEARS from the date of original retail purchase, this Litheli outdoor power equipment and power tools are warranted against defects in material or workmanship. The defective product will receive free repair or will be exchanged.

FOR ONE YEAR from the date of original retail purchase, the Litheli battery pack and charger are warranted against defects in material or workmanship. Defective products will receive free repair or be exchanged.

1. This warranty applies only to the original purchaser from an authorized Litheli shop and may not be transferred.
2. The warranty period for any Litheli product, battery pack and charger used for residential only.
3. The warranty period for routine maintenance parts, such as, but not limited to, blades, trimmer heads, chain bars, saw chains, belts, scraper bars, blower nozzles, and all other Litheli accessories is 90 days for residential purposes.
4. This warranty does not cover the damage resulting from modification, alteration or unauthorized repair.
5. This warranty only covers defects arising under normal usage and does not cover any malfunction, failure or defect resulting from misuse, abuse (including overloading of the product beyond capacity and immersion in water or other liquid), accidents, neglect or lack of proper installation, and improper maintenance or storage.
6. This warranty does not cover normal deterioration of the exterior finish including but not limited to scratches, dents, paint chips, or to any corrosion or discoloring by heat, abrasive and chemical cleaners.

WARRANTY CLAIM

For warranty claims, please contact Litheli Customer Service at service@litheli.com. You will need to submit a registration document or proof of purchase in the form of a valid receipt that displays the date and place of purchase. Replacement products do not come with a new warranty. The warranty of the products will continue from the date of the original purchase.

litheli tool