

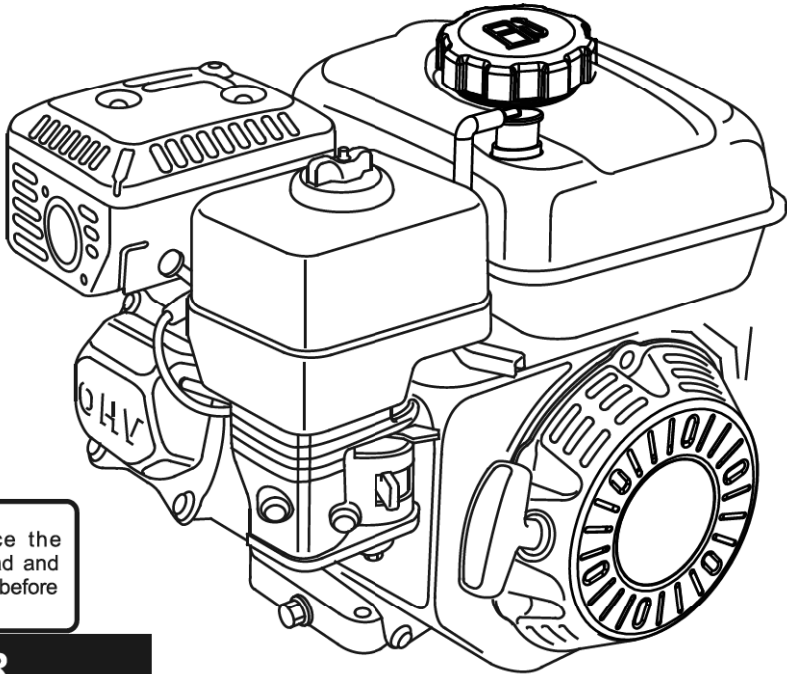

FULL BOAR

GASOLINE ENGINE OWNER'S MANUAL



WARNING: To reduce the risk of injury, the user must read and understand the operator's manual before using this product.

DANGER

Using an engine indoors
CAN KILL YOU IN MINUTES.
Engine exhaust contains carbon monoxide.
This is a poison you cannot see or smell.

NEVER use inside a home or garage, EVEN IF doors and windows are open.		Only use OUTSIDE and far away from windows, doors, and vents.

SAVE THIS MANUAL FOR FUTURE REFERENCE

NOTICE

Do not use E15 or E85 fuel in this product. It is a violation of federal law and will damage the unit and void your warranty. Only use unleaded gasoline containing up to 10% ethanol.



Save This Manual Keep this manual for the safety warnings and precautions, assembly, operating, inspection, maintenance and cleaning procedures. Write the product's serial number in the back of the manual near the assembly diagram (or month and year of purchase if product has no number).
Keep this manual and the receipt in a safe and dry place for future reference.

PREFACE

Thank you for choosing our general-purpose gasoline engine!

The manual gives information with respect to operation and maintenance of the 212cc, 236cc, 306cc general purpose gasoline engines, and be sure to read it carefully first before operation. Only operate as the manual tells, can insure user's safety and get the best results of the engine operation.

All information and diagrams of this manual are in accordance with the newest products at the publishing time. If revision and other change the information described in this manual are a little different from the actual status, our company will explain it. Our company reserves the right to make change at any time without notice and without incurring any obligation. No part of this publication may be reproduced without written permission. We strongly recommend that this product not be modified and/or used for any application other than that for which it was designed.

READ THIS OWNER'S MANUAL CAREFULLY. Pay special attention to these symbols and any instructions that follow:

⚠ WARNING

Indicates serious injury or death will result if instructions are not followed.

⚠ DANGER

Indicates a strong possibility that serious injury or death could result if instructions are not followed.

⚠ CAUTION

Indicates a possibility that minor injury or an result if instructions are not followed.

NOTICE

Indicates that equipment or property damage can result if instructions are not followed.

NOTE: Gives helpful information.

This manual should be considered a permanent part of the engine and should remain with the engine if it is resold. If a problem should arise, or if you have any questions about your engine, or for technical questions, please call (888) 533-2999.

CONTENTS

1. ENGINE SAFETY.....	1
2. COMPONENTS & CONTROL LOCATIONS.....	3
3. CONTROLS.....	4
4. CHECK BEFORE OPERATION	6
5. OPERATION.....	7
6. MAINTENANCE	11
7. STORAGE/TRANSPORTING	22
8. TROUBLESHOOTING.....	25
9. TECHNICAL & CONSUMER INFORMATION	26
10. SPECIFICATIONS	30
11. WIRING DIAGRAMS	31
12. PARTS DIAGRAM.....	32
13. LIMITED WARRANTY.....	38

1. ENGINE SAFETY

IMPORTANT SAFETY INFORMATION

Most accidents with engines can be prevented if you follow all instructions in this manual and on the engine. Some of the most common hazards are discussed below, along with the best way to protect yourself and others.

Owner Responsibilities

- The engines are designed to give safe and dependable service if operated according to instructions. Read and understand this owner's manual before operating the engine. Failure to do so could result in personal injury or equipment damage.
- Know how to stop the engine quickly, and understand the operation of all controls. Never permit anyone to operate the engine without proper instructions.
- Do not allow children to operate the engine. Keep children and pets away from the area of operation.

Refuel With Care

Gasoline is extremely flammable, and gasoline vapor can explode. Refuel outdoors, in a well-ventilated area, with the engine stopped. Never smoke near gasoline, and keep other flames and sparks away. Always store gasoline in an approved container. If any fuel is spilled, make sure the area is dry before starting the engine.

Hot Exhaust

- The muffler becomes very hot during operation and remains hot for a while after stopping the engine. Be careful not to touch the muffler while it is hot. Let the engine cool before storing it indoors.
- To prevent fire hazards and to provide adequate ventilation for stationary equipment applications, keep the engine at least 3 feet (1 meter) away from building walls and other equipment during operation. Do not place flammable objects close to the engine.

Carbon Monoxide Hazard

Exhaust gas contains poisonous carbon monoxide. Avoid inhalation of exhaust gas. Never run the engine in a closed garage or confined area.

Other Equipment

Review the instructions provided with the equipment powered by this engine for any additional safety precautions that should be observed in conjunction with engine startup, shutdown, operation, or protective apparel that may be needed to operate the equipment.

WARNING SYMBOLS AND DEFINITIONS

The safety alert symbol  is used to identify safety information about hazards that can result in personal injury.

A signal word (DANGER, WARNING, or CAUTION) is used with the alert symbol to indicate the likelihood and the potential severity of injury. In addition, a hazard symbol maybe used to represent the type of hazard.



This is the safety alert symbol. It is used to alert you to potential personal injury hazards. Obey all safety messages that follow this symbol to avoid possible injury or death.

⚠ DANGER

Indicates a hazardous situation which, if not avoided, will result in death or serious injury.

⚠ WARNING

Indicates a hazardous situation which, if not avoided, could result in death or serious injury.

⚠ CAUTION

Indicates a hazardous situation which, if not avoided, could result in minor or moderate injury.

NOTICE

Addresses practices not related to personal injury.

SYMBOL DEFINITIONS



Fire



Read Manual



Explosion



Oil



Kickback



Fuel



Hot Surface



Fuel Shutoff



Toxic Fumes



Hazardous Chemical



Moving parts



Choke



Shock



Stop



Slow



Fast

⚠ WARNING

We do not approve or authorize the use of these engines on 3 -wheel All Terrain Vehicles (ATVs), motor bike s, fun/recreational go -karts, aircraft products or vehicles intended for use in competitive events. Use of these engines in such applications could result in property damage, serious injury (including paralysis), or even death.

⚠ WARNING

The engine exhaust from this product contains chemicals known to the State of California to cause cancer, birth defects or other reproductive harm.

⚠ CAUTION

This engine is shipped from us without oil. If you starthe engine without oil, the engine will be damaged beyond repair and will not be covered under warranty.

SAFETY WARNINGS



WARNING! Read all instructions. Failure to follow all instructions listed below may result in fire, serious injury and/or DEATH. The warnings and precautions discussed in this manual cannot cover all possible conditions and situations that may occur. It must be understood by the operator that common sense and caution are factors which cannot be built into this product, but must be supplied by the operator.

SAVE THESE INSTRUCTIONS

2. COMPONENTS & CONTROL LOCATIONS

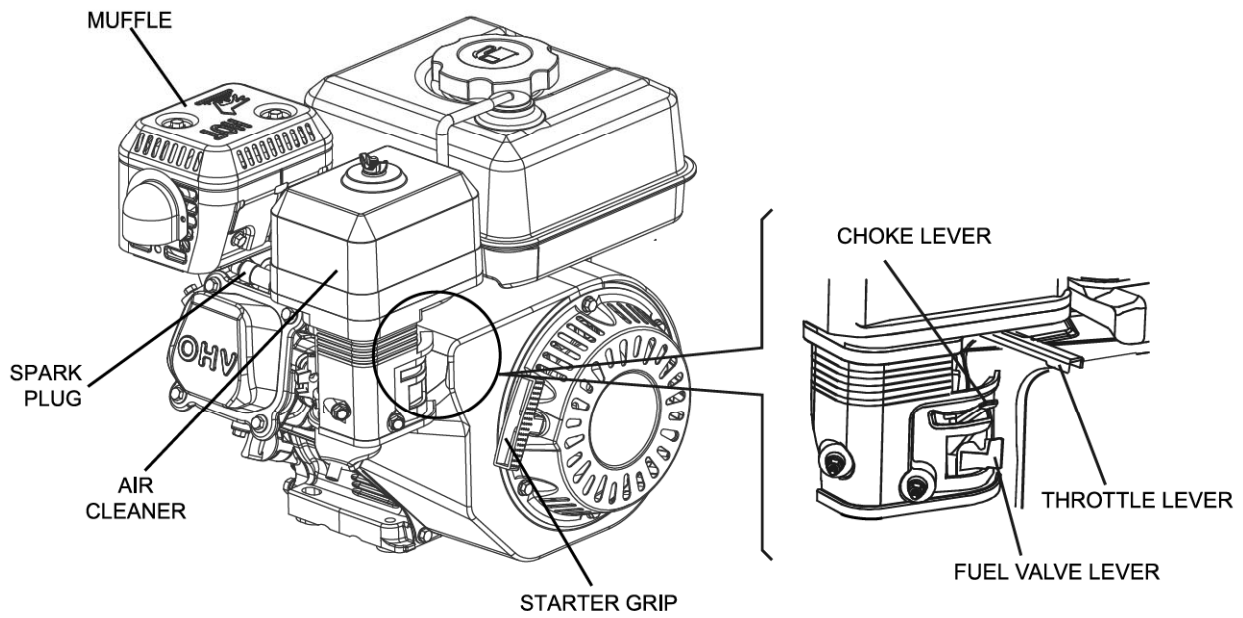
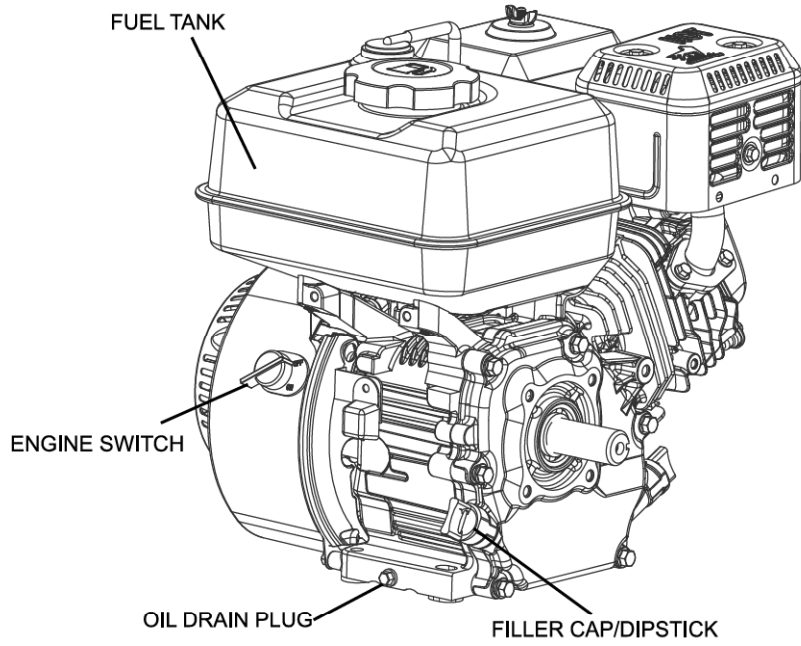

3. CONTROLS

Fuel Valve Lever

The fuel valve opens and closes the passage between the fuel tank and the carburetor. The fuel valve lever must be in the ON position for the engine to run.

When the engine is not in use, leave the fuel valve lever in the OFF position to prevent carburetor flooding and to reduce the possibility of fuel leakage.

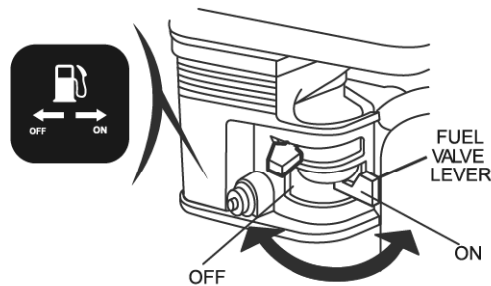

Throttle Lever

The throttle lever controls engine THROTTLE LEVER speed.

Moving the throttle lever in the directions shown makes the engine run faster or slower.

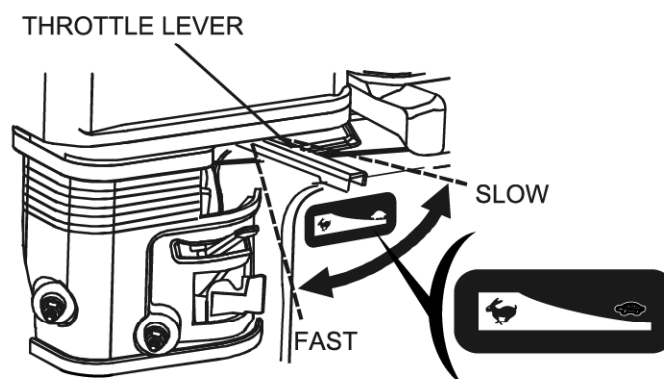

Engine Switch

The engine switch enables and disables the ignition system. The engine switch must be in the ON position for the engine to run. Turning the engine switch to the OFF position stops the engine.

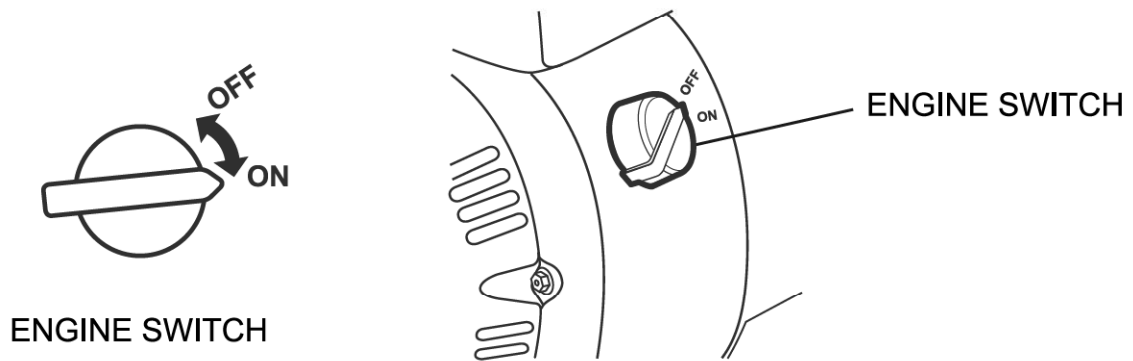

Choke Lever

The choke lever opens and closes the choke valve in the carburetor. The CLOSE position enriches the fuel mixture for starting a cold engine. The OPEN position provides the correct fuel mixture for operation after starting, and for restarting a warm engine. Some engine applications use a remotely-mounted choke control rather than the engine-mounted choke lever shown here.

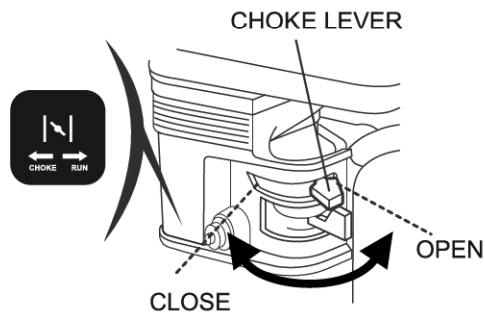

Recoil Starter Grip

Pulling the starter grip operates the recoil starter to crank the engine.

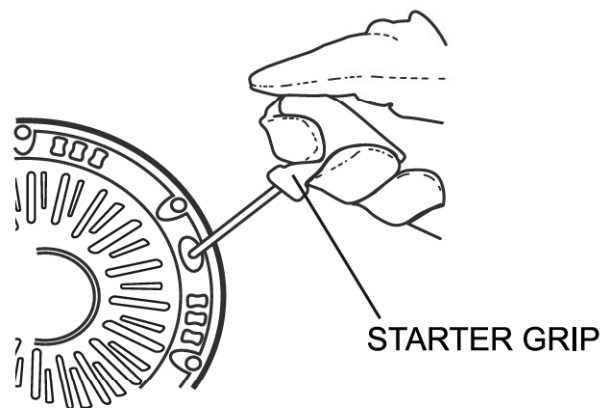

4. CHECK BEFORE OPERATION

IS YOUR ENGINE READY TO GO?

For your safety, and to maximize the service life of your equipment, it is very important to take a few moments before you operate the engine to check its condition. Be sure to take care of any problem you find, or have your servicing dealer correct it, before you operate the engine.

⚠ WARNING

Improperly maintaining this engine, or failing to correct a problem before operation, could cause a malfunction in which you could be seriously injured.

Always perform a preoperation inspection before each operation, and correct any problem.

Before beginning your preoperation checks, be sure the engine is level and the engine switch is in the OFF position.

Check the General Condition of the Engine

- Look around and underneath the engine for signs of oil or gasoline leaks.
- Remove any excessive dirt or debris, especially around the muffler and recoil starter.
- Look for signs of damage.
- Check that all shields and covers are in place, and all nuts, bolts, and screws are tightened.

Check the Engine

Check the engine oil level. Running the engine with a low oil level can cause engine damage.

The Oil Alert system will automatically stop the engine before the oil level falls below safe limits. However, to avoid the inconvenience of an unexpected shutdown, always check the engine oil level before startup.

Check the air filter. A dirty air filter will restrict air flow to the carburetor, reducing engine performance.

Check the fuel level. Starting with a full tank will help to eliminate or reduce operating interruptions for refueling.

Check the Equipment Powered by This Engine

Review the instructions provided with the equipment powered by this engine for any precautions and procedures that should be followed before engine startup.

5. OPERATION

SAFE OPERATING PRECAUTIONS

Before operating the engine for the first time, please review the **IMPORTANT SAFETY INFORMATION** and the chapter titled **BEFORE OPERATION**.

⚠ WARNING

Carbon monoxide gas is toxic.
Breathing it can cause
unconsciousness and even kill you.
Avoid any areas or actions that
expose you to carbon monoxide.

Review the instructions provided with the equipment powered by this engine for any safety precautions that should be observed in conjunction with engine startup, shutdown, or operation.

STARTING THE ENGINE

1. Move the fuel valve lever to the ON position.

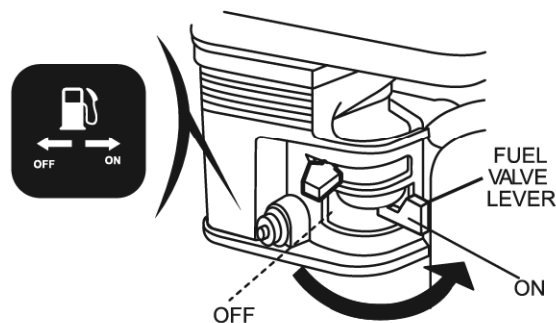

2. To start a cold engine, move the choke lever to the CLOSE position.

To restart a warm engine, leave the choke lever in the OPEN position.

Some engine applications use a remotely-mounted choke control rather than the engine-mounted choke lever shown here.

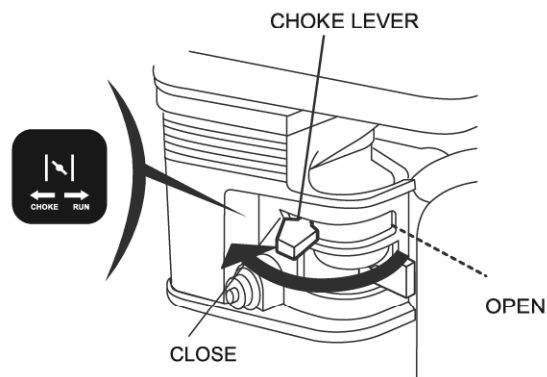

3. Move the throttle lever away from the SLOW position, about 1/3 of the way toward the FAST position.

Some engine applications use a remotely-mounted throttle control rather than the engine-mounted throttle lever shown here.

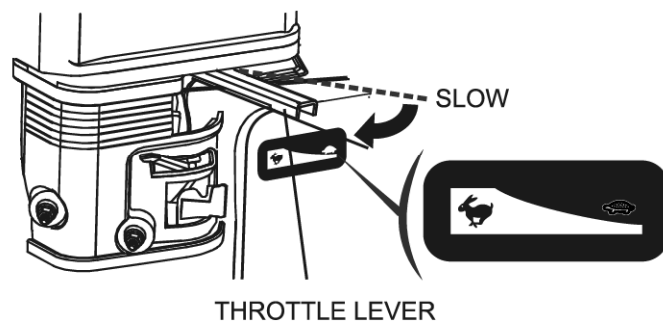

4. Turn the engine switch to the ON position.

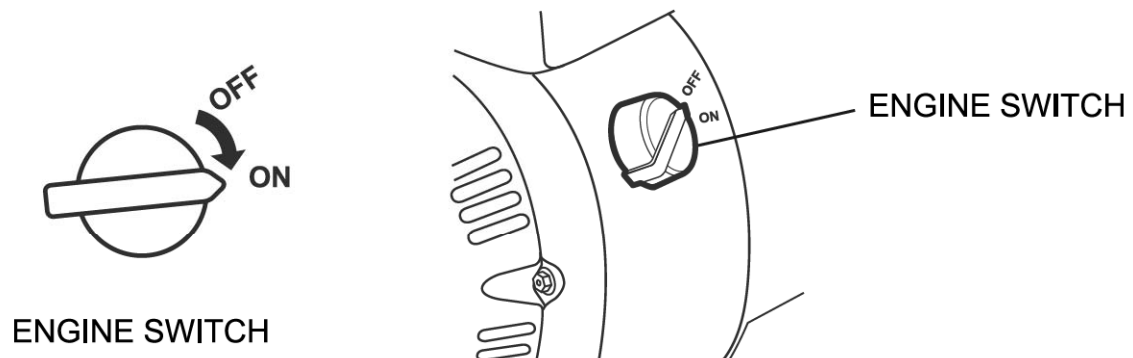

5. Operate the starter.

RECOIL STARTER (all engine types):

Pull the starter grip lightly until you feel resistance, then pull briskly.

Return the starter grip gently.

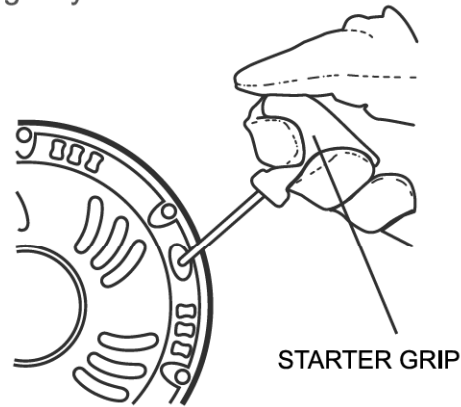

6. If the choke lever has been moved to the CLOSE position to start the engine, gradually move it to the OPEN position as the engine warms up.

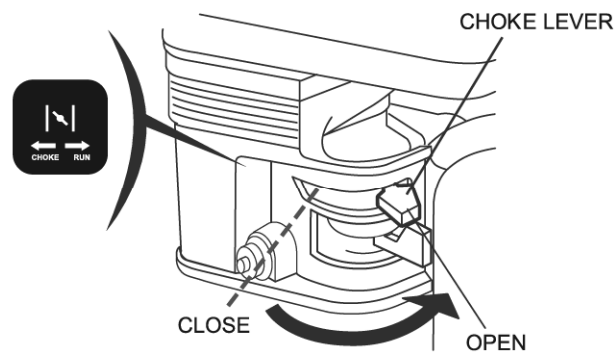

STOPPING THE ENGINE

To stop the engine in an emergency, simply turn the engine switch to the OFF position. Under normal conditions, use the following procedure.

1. Move the throttle lever to the SLOW position.
Some engine applications use a remotely-mounted throttle control rather than the engine-mounted throttle lever shown here.

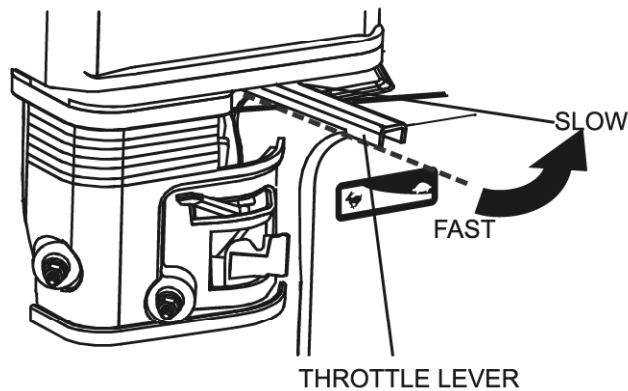

-
2. Turn the engine switch to the OFF position.

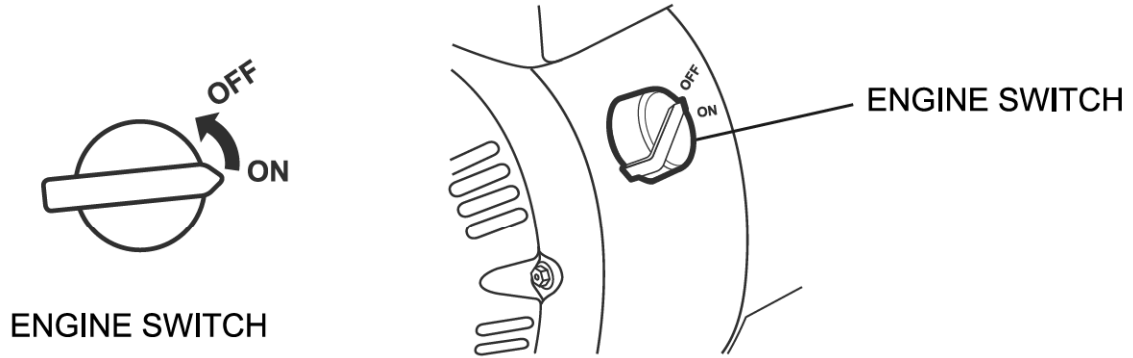

3. Turn the fuel valve lever to the OFF position.

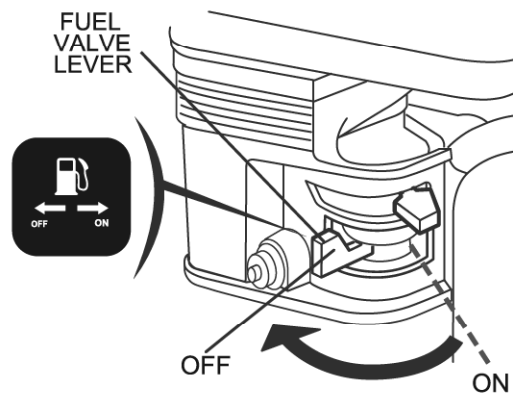

SETTING ENGINE SPEED

Position the throttle lever for the desired engine speed.

Some engine applications use a remotely-mounted throttle control rather than the engine-mounted throttle lever shown here.

For engine speed recommendations, refer to the instructions provided with the equipment powered by this engine.

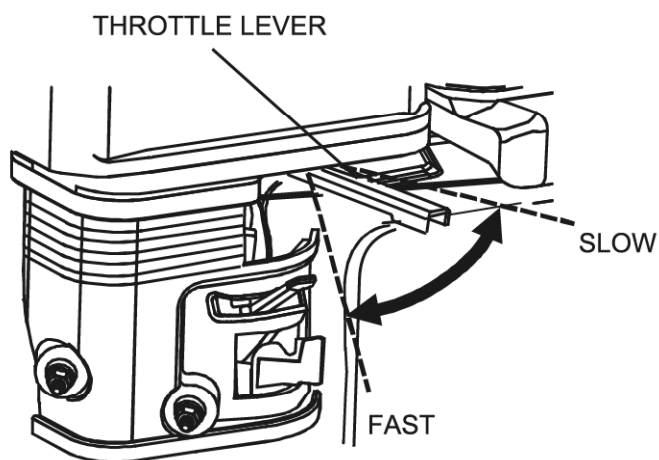

6. MAINTENANCE

THE IMPORTANCE OF MAINTENANCE

Good maintenance is essential for safe, economical, and trouble-free operation. It will also help reduce air pollution.

⚠ WARNING

Improperly maintaining this engine, or failure to correct a problem before operation, can cause a malfunction in which you can be seriously hurt or killed.

Always follow the inspection and maintenance recommendations and schedules in this owner's manual.

To help you properly care for your engine, the following pages include a maintenance schedule, routine inspection procedures, and simple maintenance procedures using basic hand tools. Other service tasks that are more difficult, or require special tools, are best handled by professionals and are normally performed by a technician or other qualified mechanic.

The maintenance schedule applies to normal operating conditions. If you operate your engine under unusual conditions, such as sustained high-load or high-temperature operation, or use in unusually wet or dusty conditions, consult your servicing dealer for recommendations applicable to your individual needs and use.

MAINTENANCE SAFETY

Some of the most important safety precautions are as follows: However, we cannot warn you of every conceivable hazard that can arise in performing maintenance. Only you can decide whether or not you should perform a given task.

⚠ WARNING

Failure to properly follow maintenance instructions and precautions can cause you to be seriously hurt or killed.

Always follow the procedures and precautions in the owner's manual.

Safety Precautions

- Make sure the engine is off before you begin any maintenance or repairs. This will eliminate several potential hazards:

■ **Carbon monoxide poisoning from engine exhaust.**

Be sure there is adequate ventilation whenever you operate the engine.

■ **Burns from hot parts.**

Let the engine and exhaust system cool before touching.

■ **Injury from moving parts.**

Do not run the engine unless instructed to do so.

- Read the instructions before you begin, and make sure you have the tools and skills required.
- To reduce the possibility of fire or explosion, be careful when working around gasoline. Use only a nonflammable solvent, not gasoline, to clean parts. Keep cigarettes, sparks and flames away from all fuel-related parts.

Remember that your servicing dealer knows your engine best and is fully equipped to maintain and repair it.

To ensure the best quality and reliability, use only new, genuine parts or their equivalents for repair and replacement.

MAINTENANCE SCHEDULE

REGULAR SERVICE PERIOD (3) Perform at every indicated month or operating hour interval, whichever comes first.		Each use	First Month or 20 Hrs	Every 3 Months or 50 Hrs	Every 6 Months or 100 Hrs	Every Year or 300 Hrs
Item						
Engine Oil	Check level	○				
	Change		○		○	
Air Cleaner	Check	○				
	Clean			○(1)		
	Replace					○☆
Sediment Cup	Clean				○	
Spark Plug	Check-adjust				○	
	Replace					○
Spark Arrester (optional parts)	Clean				○	
Idle Speed	Check-adjust					○(2)
Valve Clearance	Check-adjust					○(2)
Fuel Tank & Filter	Clean				○(2)	
Combustion Chamber	Clean	After every 300 Hrs.(2)				
Fuel Tube	Check	Every 2 years (Replace if necessary) (2)				

● Emission-related items.

☆ Replace the paper element type only.

(1) Service more frequently when used in dusty areas.

(2) These items should be serviced by your servicing dealer unless you have the proper

tools and are mechanically proficient. Refer to manual for service procedures.

REFUELING

Fuel tank capacities

212cc/236cc:3.6L

306cc:6.0L

With the engine stopped, remove the fuel tank cap and check the fuel level. Refill the tank if the fuel level is low.

⚠ WARNING

Gasoline is highly flammable and explosive. You can be burned or seriously injured when handling fuel.

- Stop the engine and keep heat, sparks, and flame away.
- Handle fuel only outdoors.
- Wipe up spills immediately.

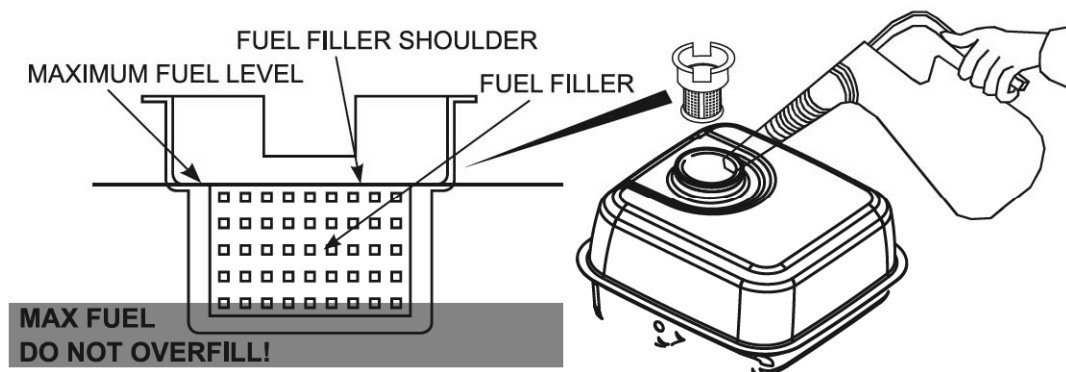

Refuel in a well-ventilated area before starting the engine. If the engine has been running, allow it to cool. Refuel carefully to avoid spilling fuel. Do not fill above the fuel strainer shoulder. After refueling, tighten the fuel tank cap securely.

Never refuel the engine inside a building where gasoline fumes may reach flames or sparks. Keep gasoline away from appliance pilot lights, barbecues, electric appliances, power tools, etc.

Spilled fuel is not only a fire hazard, it causes environmental damage. Wipe up spills immediately.

NOTICE

Fuel can damage paint and plastic. Be careful not to spill fuel when filling your fuel tank. Damage caused by spilled fuel is not covered under warranty.

FUEL RECOMMENDATIONS

Use unleaded gasoline with a pump octane rating of 86 or higher.

These engines are certified to operate on unleaded gasoline. Unleaded gasoline produces fewer engine and spark plug deposits and extends exhaust system life.

Never use stale or contaminated gasoline or an oil/gasoline mixture. Avoid getting dirt or water in the fuel tank.

Occasionally you may hear a light “spark knock” or “pinging” (metallic rapping noise) while operating under heavy loads. This is no cause for concern.

If spark knock or pinging occurs at a steady engine speed, under normal load, change brands of gasoline. If spark knock or pinging persists, see an authorized servicing dealer.

NOTICE

Running the engine with persistent spark knock or pinging can cause engine damage.

Running the engine with persistent spark knock or pinging is considered misuse, and the Distributor’s Limited Warranty does not cover parts damaged by misuse.

ENGINE OIL LEVEL CHECK

Check the engine oil level with the engine stopped and in a level position.

1. Remove the filler cap/dipstick and wipe it clean.

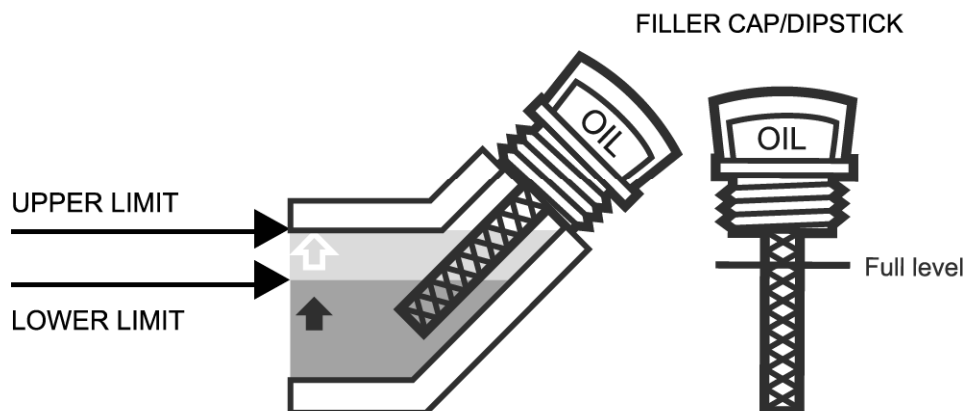

-
2. Insert and remove the dipstick without screwing it into the filler neck. Check the oil level shown on the dipstick.
 3. If the oil level is low, fill to the edge of the oil filler hole with the recommended oil.
 4. Screw in the filler cap/dipstick securely.

NOTICE *Running the engine with a low oil level can cause engine damage.*

The Oil Alert system will automatically stop the engine before the oil level falls below safe limit. However, to avoid the inconvenience of an unexpected shutdown, always check the engine oil level before startup.

ENGINE OIL CHANGE

Drain the used oil while the engine is warm. Warm oil drains quickly and completely.

1. Place a suitable container below the engine to catch the used oil, and then remove the filler cap/dipstick and the drain plug. Slant the engine with the angle of a certain degree to help drain more quickly and completely.

2. Allow the used oil to drain completely, and then reinstall the drain plug, and tighten it securely.

Please dispose of used motor oil in a manner that is compatible with the environment. We suggest you take used oil in a sealed container to your local recycling center or service station for reclamation. Do not throw it in the trash; pour it on the ground; or down a drain.

3. With the engine in a level position, fill to the outer edge of the oil filler hole with the recommended oil.

Engine oil capacities:

212cc/236cc: 0.6L

306cc: 1.1L

Running the engine with a low oil level can cause engine damage.

The Oil Alert system will automatically stop the engine before the oil level falls below the safe limit.

However, to avoid the inconvenience of an unexpected shutdown, fill to the upper limit, and check the oil level regularly.

4. Screw in the filler cap/dipstick securely.

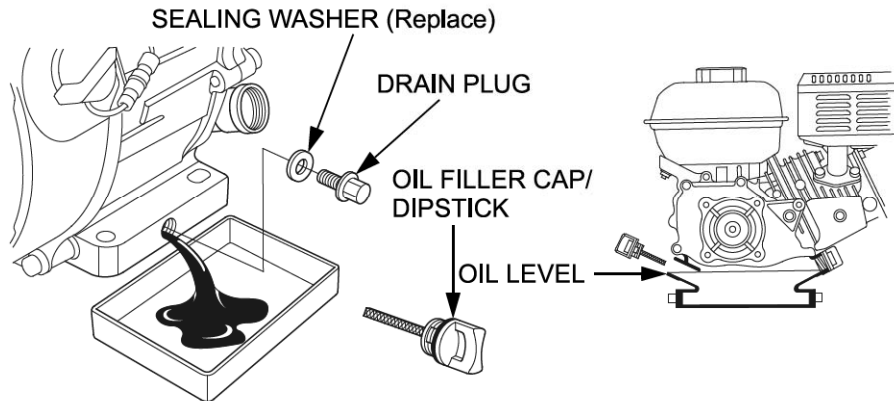

SERVICING YOUR ENGINE

ENGINE OIL RECOMMENDATIONS

Oil is a major factor affecting performance and service life. Use 4-stroke automotive detergent oil.

SAE 10W-30 is recommended for general use. Other viscosities shown in the chart may be used when the average temperature in your area is within the recommended range.

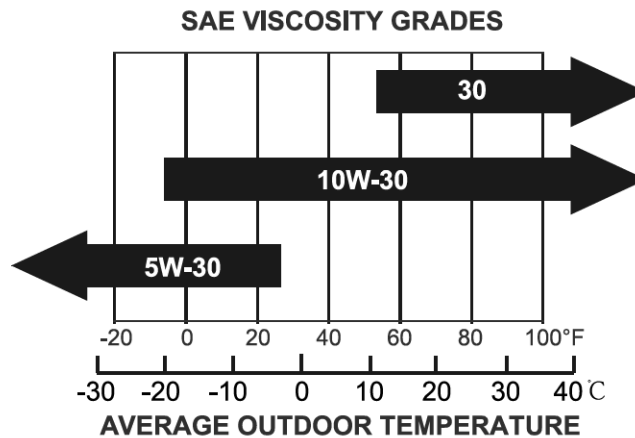

AMBIENT TEMPERATURE

The SAE oil viscosity and service classification are in the API label on the oil container. We recommend that you use API SERVICE Category SE or SF oil.

AIR FILTER INSPECTION

Remove the air cleaner cover and inspect the filter. Clean or replace dirty filter elements. Always replace damaged filter elements.

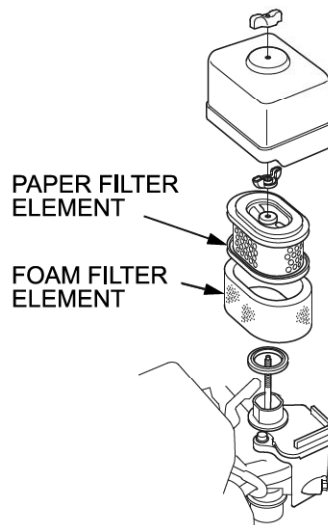

AIR CLEANER SERVICE

A dirty air filter will restrict air flow to the carburetor, reducing engine performance.

If you operate the engine in very dusty areas, clean the air filter more often than specified in the MAINTENANCE SCHEDULE.

NOTICE

Operating the engine without an air filter, or with a damaged air filter, will allow dirt to enter the engine, causing rapid engine wear. This type of damage is not covered by the Distributor's Limited Warranty.

Dual-Filter-Element Types Applicable for Engine Model:

212cc/236cc/306cc

1. Remove the wing nut from the air cleaner cover, and remove the air cleaner cover.
2. Remove the wing nut from the air filter, and remove the filter.
3. Remove the foam filter from the paper filter.
4. Inspect both air filter elements, and replace them if they are damaged. Always replace the paper air filter element at the scheduled interval.

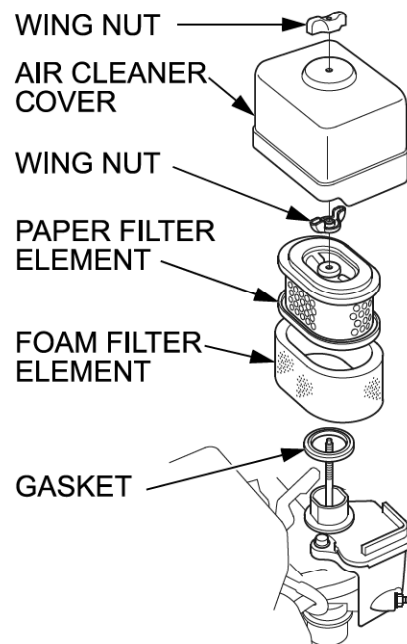

5. Clean the air filter elements if they are to be reused.

Paper air filter element: Tap the filter element several times on a hard surface to remove dirt, or blow compressed air [not exceeding 30 psi (207 kPa)] through the filter element from the inside. Never try to brush off dirt; brushing will force dirt into the fibers.

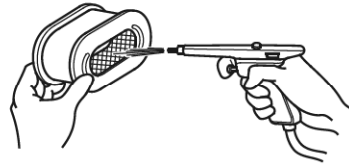

Foam air filter element: Clean in warm soapy water, rinse, and allow drying thoroughly. Or clean in nonflammable solvent and allow drying. Dip the filter element in clean engine oil, and then squeeze out all excess oil. The engine will smoke when started if too much oil is left in the foam.

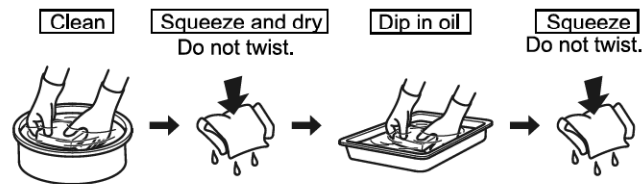

6. Wipe dirt from the inside of the air cleaner base and cover, using a moist rag. Be careful to prevent dirt from entering the air duct that leads to the carburetor.
7. Place the foam air filter element over the paper element, and reinstall the assembled air filter. Be sure the gasket is in place beneath the air filter. Tighten the air filter wing nut securely.
8. Install the air cleaner cover, and tighten the cover wing nut securely.

SEDIMENT CUP CLEANING

1. Move the fuel valve to the OFF position, and then remove the fuel sediment cup and O-ring.

⚠ WARNING

Gasoline is highly flammable and explosive. You can be burned or seriously injured when handling fuel.

- Keep heat, sparks and flame away.
- Handle fuel only outdoors.
- Wipe up spills immediately.
- Start the engine more than 3 meters away from the place of refueling.

2. Wash the sediment cup and O-ring in nonflammable solvent, and dry them thoroughly.
3. Place the O-ring in the fuel valve, and install the sediment cup. Tighten the sediment cup securely.
4. Move the fuel valve to the ON position, and check for leaks. Replace the O-ring if there is any leakage.

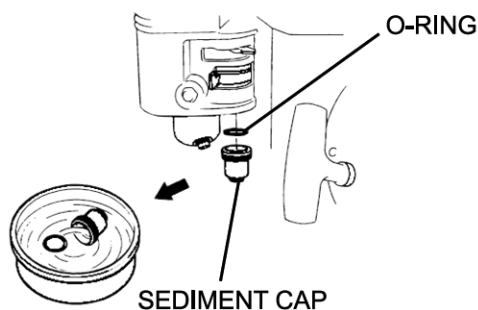

SPARK PLUG SERVICE

Recommended spark plugs: F6RTC/F6TC

Or other equivalents.

	F6RTC/F6TC
CHAMPION	RN6YC/RN6Y
NGK	BPR6ES
DENSO	W20EPR_U
BOSCH	WR7DC

NOTICE

An incorrect spark plug can cause engine damage.

1. Disconnect the spark plug cap, and remove any dirt from around the spark plug area.
2. Remove the spark plug with a spark plug wrench.

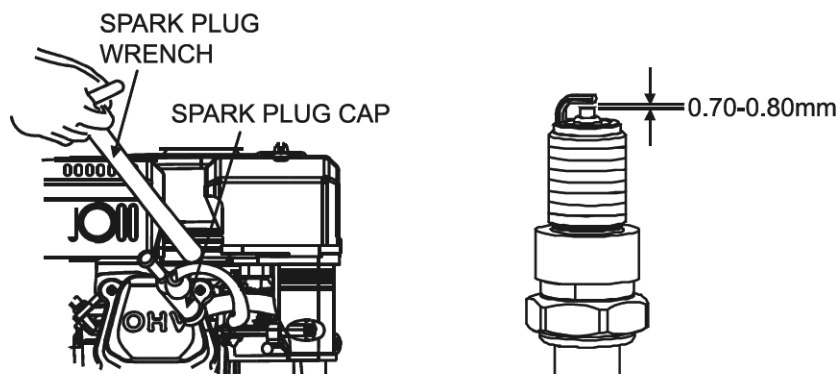

3. Inspect the spark plug. Replace it if the electrodes are worn, or if the insulator is cracked or chipped.

-
4. Measure the spark plug electrode gap with a suitable gauge.
The gap should be 0.028 in -0.031 in (0.70 mm - 0.80 mm). Correct the gap, if necessary, by carefully bending the side electrode.
 5. Install the spark plug carefully, by hand, to avoid cross-threading.
 6. After the spark plug seats, tighten with a spark plug wrench to compress the water.

If reinstalling the used spark plug , tighten 1/8 - 1/4 turn after the spark plug seats.

If installing a new spark plug, tighten 1/2 turn after the spark plug seats.

NOTICE

***A loose spark plug can overheat and damage the engine.
Over tightening the spark plug can damage the threads in the cylinder head.***

7. Attach the spark plug cap.

IDLE SPEED ADJUSTMENT

1. Start the engine outdoors, and allow it to warm up to operating temperature.
2. Move the throttle lever to its slowest position.
3. Turn the throttle stop screw to obtain the standard idle speed.
Standard idle speed: 1,400±150 rpm

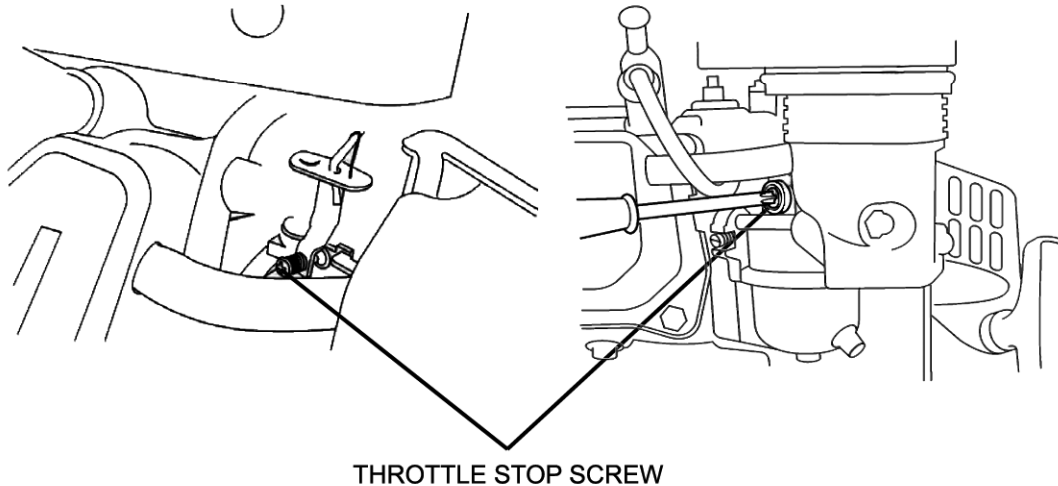

SPARK ARRESTER SERVICE (optional equipment)

Your engine is not factory-equipped with a spark arrester. In some areas, it is illegal to operate an engine without a spark arrester. Check local laws and regulations. A spark arrester is available from authorized servicing dealers.

The spark arrester must be serviced every 100 hours to keep it functioning as designed.

If the engine has been running, the muffler will be very hot. Allow the muffler to cool before servicing the spark arrester.

1. Remove the three 4 mm screws from the exhaust deflector, and remove the deflector.
2. Remove the four 5 mm screws from the muffler protector and remove the muffler protector.
3. Remove the 4 mm screw from the spark arrester, and remove the spark arrester from the muffler.

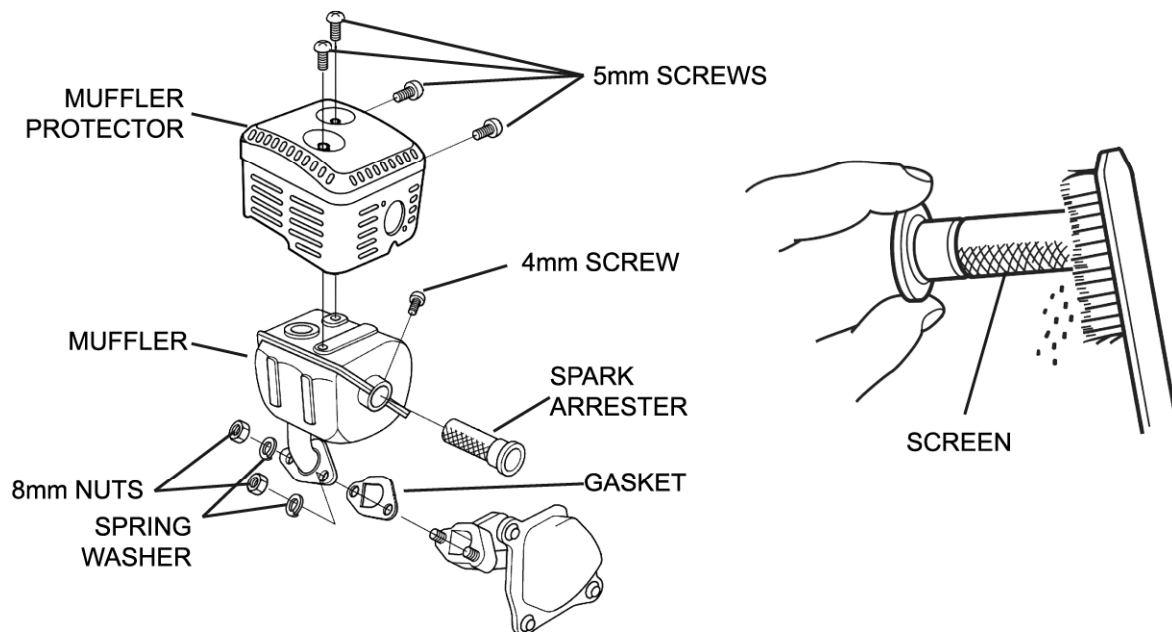

4. Use a brush to remove carbon deposits from the spark arrester screen. Be careful to avoid damaging the screen.

The spark arrester must be free of breaks and holes. Replace the spark arrester if it is damaged.

5. Install the spark arrester, muffler protector, and exhaust deflector in the reverse order of disassembly.

⚠ WARNING Never use an engine without an appropriate spark arrester in the forest areas! Doing so may cause a fire!

7. STORAGE/ TRANSPORTING

STORING YOUR ENGINE

Storage Preparation

Proper storage preparation is essential for keeping your engine trouble free and looking good. The following steps will help to keep rust and corrosion from impairing your engine's function and appearance, and will make the engine easier to start after storage.

Cleaning

If the engine has been running, allow it to cool for at least half an hour before cleaning. Clean all exterior surfaces, touch up any damaged paint, and coat other areas that may rust with a light film of oil.

NOTICE

- ***Using a garden hose or pressure washing equipment can force water into the air cleaner or muffler opening. Water in the air cleaner will soak the air filter, and water that passes through the air filter or muffler can enter the cylinder, causing damage.***
- ***Water contacting a hot engine can cause damage. If the engine has been running, allow it to cool for at least half an hour before washing.***

Fuel

Gasoline will oxidize and deteriorate in storage. Old gasoline will cause hard starting, and it leaves gum deposits that clog the fuel system. If the gasoline in your engine deteriorates during storage, you may need to have the carburetor and other fuel system components serviced or replaced.

Gasoline is mixture of different material. Gasoline left in fuel tank and carburetor will cause functional problems. The causing time varies under different factors, such as storing temperature, fuel tank partially or completely filled. The air in the tank can cause fuel deterioration when fuel tank is partially filled. High storing temperature accelerates fuel deterioration. Fuel deterioration may occur within a few months or even less, when the gasoline is not fresh during refueling.

The Distributor's Limited Warranty does not cover fuel system damage or engine performance problems resulting from neglected storage preparation.

You can extend fuel storage life by adding a fuel stabilizer that is formulated for that purpose, or you can avoid fuel deterioration problems by draining the fuel tank and carburetor.

ADDING A FUEL STABILIZER TO EXTEND FUEL STORAGE LIFE

When adding a fuel stabilizer, fill the fuel tank with fresh gasoline. If only partially filled, air in the tank will promote fuel deterioration during storage. If you keep a container of gasoline for refueling, be sure that it contains only fresh gasoline.

1. Add fuel stabilizer following the manufacturer's instructions.
2. After adding a fuel stabilizer, run the engine outdoors for 10 minutes to be sure that treated gasoline has replaced the untreated gasoline in the carburetor.
3. Stop the engine, and move the fuel valve to the OFF position.

DRAINING THE FUEL TANK AND CARBURETOR

1. Place an approved gasoline container below the carburetor, and use a funnel to avoid spilling fuel.
2. Remove the carburetor drain bolt and sediment cup, and then move the fuel valve lever to the ON position.

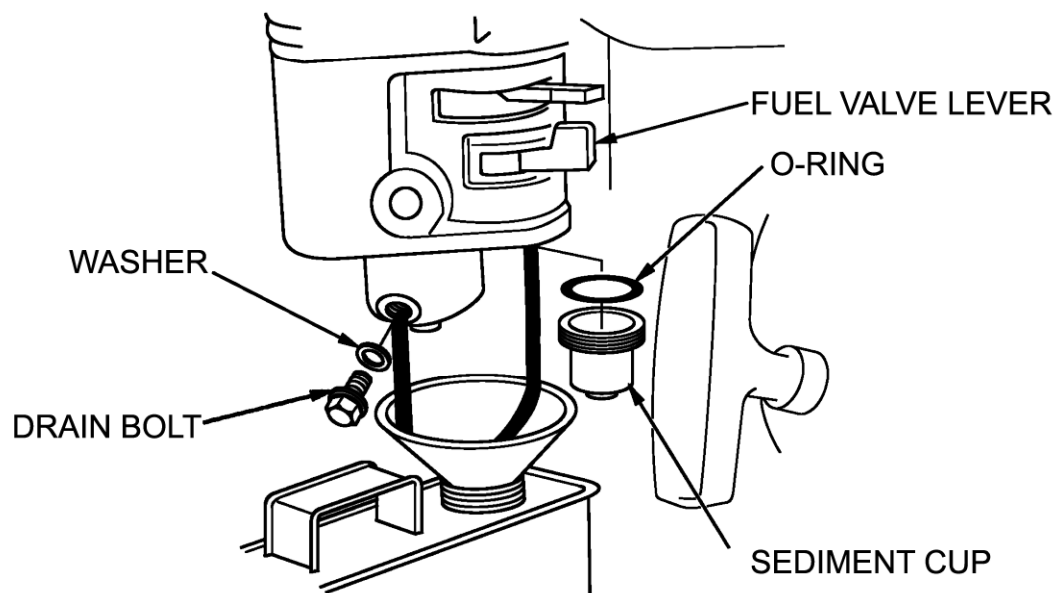

3. After all the fuel has drain into the container, reinstall the drain bolt and sediment cup. Tighten them securely.

Storage Precautions

1. Change the engine oil.
2. Remove the spark plugs.

-
3. Pour a tablespoon (5-10 cc) of clean engine oil into the cylinder.
 4. Pull the starter rope several times to distribute the oil in the cylinder.
 5. Reinstall the spark plugs.
 6. Pull the starter rope slowly until resistance is felt. This will close the valves so moisture cannot enter the engine cylinder. Return the starter rope gently.

If your engine will be stored with gasoline in the fuel tank and carburetor, it is important to reduce the hazard of gasoline vapor ignition. Select a well-ventilated storage area away from any appliance that operates with a flame, such as a furnace, water heater, or clothes dryer. Also avoid any area with a spark-producing electric motor, or where power tools are operated.

If possible, avoid storage areas with high humidity, because that promotes rust and corrosion.

Unless all fuel has been drained from the fuel tank, leave the fuel valve lever in the OFF position to reduce the possibility of fuel leakage.

Position the equipment so the engine is level. Tilting can cause fuel or oil leakage.

With the engine and exhaust system cool, cover the engine to keep out dust. A hot engine and exhaust system can ignite or melt some materials. Do not use sheet plastic as a dust cover. A nonporous cover will trap moisture around the engine, promoting rust and corrosion.

If equipped with a battery for an electric starter, recharge the battery once a month while the engine is in storage. This will help to extend the service life of the battery.

Removal from Storage

Check your engine as described in the chapter CHECK BEFORE OPERATION.

If the fuel was drained during storage preparation, fill the tank with fresh gasoline. If you keep a container of gasoline for refueling, be sure that it contains only fresh gasoline. Gasoline oxidizes and deteriorates over time, causing hard starting.

If the cylinders were coated with oil during storage preparation, the engine may smoke briefly at startup. This is normal.

TRANSPORTING

If the engine has been running, allow it to cool for at least 15 minutes before loading the engine-powered equipment on the transport vehicle. A hot engine and exhaust system can burn you and can ignite some materials.

Keep the engine level when transporting to reduce the possibility of fuel leakage. Move the fuel valve lever to the OFF position.

8. TROUBLESHOOTING

ENGINE WILL NOT START	Possible Cause	Correction
1. Electric starting: check battery	Battery discharged.	Recharge battery.
2. Check control positions	Fuel valve OFF.	Move lever to ON.
	Choke OPEN.	Move lever to CLOSE unless engine is warm.
	Engine switch OFF.	Turn engine switch to ON.
3. Check fuel.	Out of fuel.	Refuel
	Bad fuel; engine stored without treating or draining gasoline, or refueled with bad gasoline.	Drain fuel tank and carburetor. Refuel with fresh gasoline.
4. Remove and inspect spark plugs.	Spark plugs faulty, fouled, or improperly gapped.	Gap, or replace spark plugs.
	Spark plugs wet with fuel (flooded engine).	Dry and reinstall spark plugs. Start engine with throttle lever in FAST position.
5. Take engine to an authorized servicing dealer, or refer to manual.	Fuel filter clogged, carburetor malfunction, ignition malfunction, valve stuck, etc.	Replace or repair faulty components as necessary.

ENGINE LACKS POWER	Possible Cause	Correction
1. Check air filter	Filter element(s) clogged.	Clean or replace filter element(s).
2. Check fuel.	Out of fuel.	Refuel
	Bad fuel; engine stored without treating or draining gasoline, or refueled with bad gasoline.	Drain fuel tank and carburetor. Refuel with fresh gasoline.
3. Take engine to an authorized servicing dealer, or refer to manual.	Fuel filter clogged, carburetor malfunction, ignition malfunction, valve stuck, etc.	Replace or repair faulty components as necessary.

9. TECHNICAL & CONSUMER INFORMATION

TECHNICAL INFORMATION

Serial Number Location

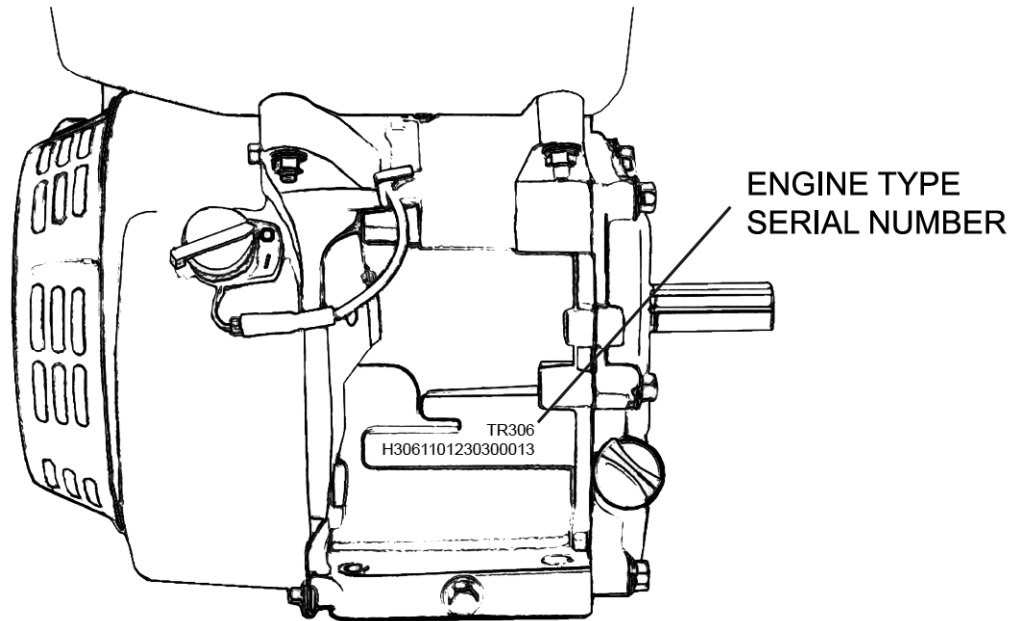

Record the engine serial number in the space below. You will need this serial number when ordering parts, and when making technical or warranty inquiries.

Engine serial number: _____

Carburetor Modification for High Altitude Operation

At high altitude, the standard carburetor air-fuel mixture will be too rich. Performance will decrease, and fuel consumption will increase. A very rich mixture will also foul the spark plug and cause hard starting. Operation at an altitude that differs from that at which this engine was certified, for extended periods of time, may increase emissions.

High altitude performance can be improved by specific modifications to the carburetor. If you always operate your engine at altitudes above 5,000 feet (1,500 meters), have your servicing dealer perform this carburetor modification. This engine, when operated at high altitude with the carburetor modifications for high altitude use, will meet each emission standard throughout its useful life.

Even with carburetor modification, engine horsepower will decrease about 3.5% for each 1,000-foot (300-meter) increase in altitude. The effect of altitude on horsepower will be greater than this if no carburetor modification is made.

NOTICE

When the carburetor has been modified for high altitude operation, the air-fuel mixture will be too lean for low altitude use. Operation at altitudes below 5,000 feet (1,500meters) with a modified carburetor may cause the engine to overheat and result in serious engine damage. For use at low altitudes, have your servicing dealer return the carburetor to original factory specifications.

Oxygenated Fuels

Some conventional gasolines are being blended with alcohol or an ether compound. These gasolines are collectively referred to as oxygenated fuels. To meet clean air standards, some areas use oxygenated fuels to help reduce emissions.

If you use an oxygenated fuel, be sure it is unleaded and meets the minimum octane rating requirement.

Before using an oxygenated fuel, try to confirm the fuel's contents. Some areas require this information to be posted on the pump.

The following are the EPA approved percentages of oxygenates:

ETHANOL —————(ethyl or grain alcohol) 10% by volume You may use gasoline containing up to 10% ethanol by volume. Gasoline containing ethanol may be marketed under the name "Gasohol".

MTBE —————(methyl tertiary butyl ether) 15% by volume You may use gasoline containing up to 15% MTBE by volume.

METHANOL —————(methyl or wood alcohol) 5% by volume You may use gasoline containing up to 5% methanol by volume, as long as it also contains cosolvents and corrosion inhibitors to protect the fuel system. Gasoline containing more than 5% methanol by volume may cause starting and/or performance problems. It may also damage metal, rubber, and plastic parts of your fuel system.

If you notice any undesirable operating symptoms, try another service station, or switch to another brand of gasoline.

Fuel system damage or performance problems resulting from the use of an oxygenated fuel containing more than the percentages of oxygenates mentioned above are not covered under warranty.

Emission Control System Information

If you are aware of any of the
Source of Emissions

If you are aware of any of the

The combustion process produces carbon monoxide, oxides of nitrogen, and hydrocarbons. Control of hydrocarbons and oxides of nitrogen is very important because, under certain conditions, they react to form photochemical smog when subjected to sunlight. Carbon monoxide does not react in the same way, but it is toxic.

This utilizes lean carburetor settings and other systems to reduce the emissions of carbon monoxide, oxides of nitrogen and hydrocarbons.

Tampering and Altering Tampering with or altering the emission control system may increase emissions beyond the legal limit. Among those acts that constitute tampering are:

- Removal or alteration of any part of the intake, fuel or exhaust systems.
- Altering or defeating the governor linkage or speed-adjusting mechanism to cause the engine to operate outside its design parameters.

Problems That May Affect Emissions

If you are aware of any of the following symptoms, have your engine inspected and repaired by your servicing dealer.

- Hard starting or stalling after starting.
- Rough idle.
- Misfiring or backfiring under load.
- Afterburning (backfiring).
- Black exhaust smoke or high fuel consumption.

Replacement Parts

The emission control systems on your engine were designed, built. We recommend the use of genuine parts whenever you have maintenance done. These original-design replacement parts are manufactured to the same standards as the original parts, so you can be confident of their performance. The use of replacement parts that are not of the original design and quality may impair the effectiveness of your emission control system.

A manufacturer of an aftermarket part assumes the responsibility that the part will not adversely affect emission performance. The manufacturer or rebuilder of the part must certify that use of the part will not result in a failure of the engine to comply with emission regulations.

Maintenance

Follow the maintenance schedule. Remember that this schedule is based on the assumption that your machine will be used for its designed purpose. Sustained high-load or high-temperature operation, or use in unusually wet or dusty conditions, will require more frequent service.

Engine Tune-up

ITEM	SPECIFICATION
Spark plug gap	0.028-0.031 in (0.70 mm -0.80 mm)
Valve clearance	IN: 0.15 mm \pm 0.02 mm (cold) EX: 0.20 mm \pm 0.02 mm (cold)
Other specifications	No other adjustments needed

CONSUMER INFORMATION

Publications

These publications will give you additional information for maintaining and repairing your engine. You may order them from your engine dealer.

Parts Catalog

This manual provides complete, illustrated parts lists.

QUICK REFERENCE INFORMATION

Engine Oil	Type	SAE 10W-30,API SE or SF, for general use
	Capacity	1. 212cc/236cc:0.6L 2. 306cc:1.1L
Spark Plug	Type	F6RTC/F6TC or other equivalents.
	Gap	0.028—0.031 in (0.70 mm—0.80 mm)
Carburetor	Idle speed	1400 rpm \pm 150 rpm
Maintenance	Each use	Check engine oil. Check air filter.
	First 20 hours	Change engine oil.
	Subsequent	Refer to the maintenance

10. SPECIFICATIONS

Model	212cc	236cc	306cc
Type	Single cylinder, 4-Stroke, Forced Air Cooling, OHV		
Rated Power(kW/3600rpm)	4.3	4.7	6.5
Max. Torque(N·m/rpm)	12.0/3000	13.1/3000	18.0/3000
Fuel Consumption(g/kW·h)	≤395		≤374
Idle Speed	1800±200		
Speed Fluctuating Ratio	≤10%		
Noise(≤)	70db(A)		80db(A)
Bore×Stroke(mm)	70×55	72×58	82×58
Displacement(cc)	212	236	306
Compression Ratio	8.5:1		8.2:1
Lubricating mode	Splash		
Starting Mode	Recoil start(Recoil start / Electric starting)		
Rotation	Anti-clockwise(from P.T.O. side)		
Valve Clearance	input valve: 0.10 mm ~0.15mm, output valve: 0.15 mm ~0.20mm		
Spark Plug Clearance	0.7 mm ~0.8mm		
Igniting Mode	Transistorized Magneto Ignition		
Air cleaner	Semi-dry, Oil bath, Foam filter		
Dimension(Length) (mm)	390	395	480
Dimension(Width) (mm)	335	345	405
Dimension(High) (mm)	370	370	460
Net weight(kg)	16.5	17.5	27.0

11. Wiring Diagrams

WITH OIL ALERT AND WITHOUT ELECTRIC STARTER

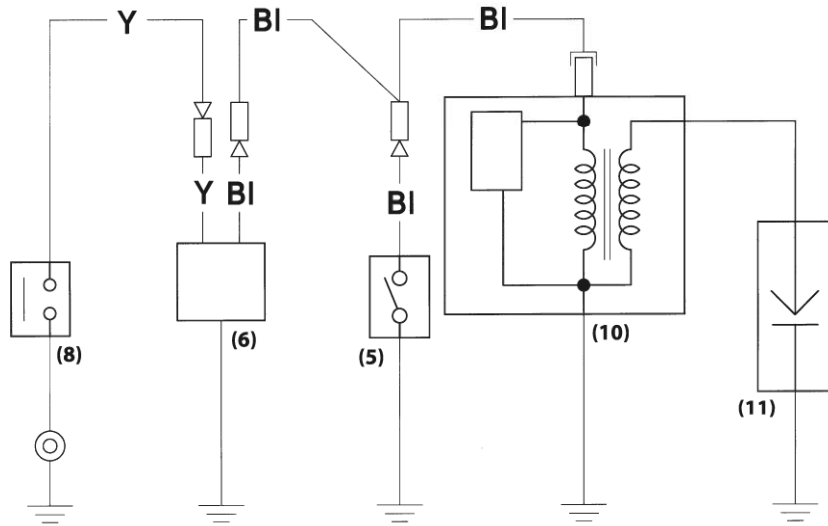

- (5) ENGINE SWITCH
- (6) OIL ALERT UNIT
- (8) OIL LEVEL SWITCH
- (10) IGNITION COIL
- (11) SPARK PLUG

	IG	E
OFF	○	○
ON		

BI	Black
Y	Yellow

12. PARTS DIAGRAM

- TR212

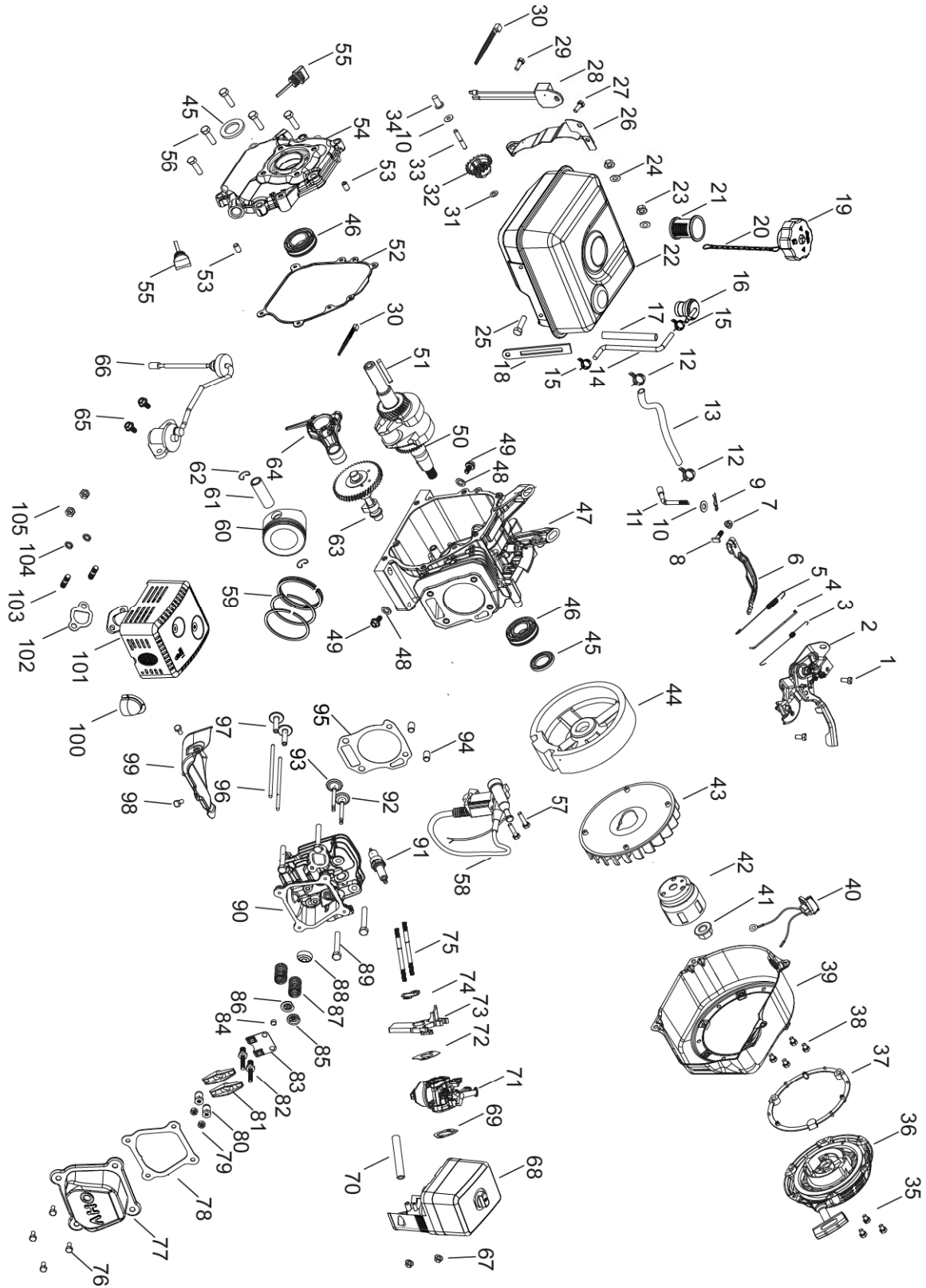

● TR212 Parts List

NO.	PART NO.	DESCRIPTION	QTY	NO.	PART NO.	DESCRIPTION	QTY	NO.	PART NO.	DESCRIPTION	QTY
1	TGS410236	FLANGE BOLT 6×12	2	37	TGH414325	RECOIL STARTER SPACER	1	73	TGH414600	CARBURETOR SPACER	1
2	TGH417900	CONTROL ASSY.	1	38	TGS410236	FLANGE BOLT 6×12	4	74	TGH414626	GASKET, SPACER/CYLINDER HEAD	1
3	TGH417975	GOVERNOR SPRING(GOVERNOR ROD)	1	39	TGH413800	FAN COVER COMP	1	75	TGH410126	INTAKE BOLT STUD(6×112)	2
4	TGH417925	GOVERNOR ROD	1	40	TGH414100	ENGINE STOP SWITCH ASSY.	1	76	TGS410242	FLANGE BOLT 6×16	4
5	TGH417951	GOVERNOR SPRING(GOVERNOR)	1	41	TGH417325	SPECIAL NUT M16×1.5	1	77	TGH410200	HEAD COVER COMP	1
6	TGH418000	GOVERNOR ARM	1	42	TGH414001	STARTER PULLEY	1	78	TGH410225	GASKET, HEAD COVER	1
7	TGS210075	FLANGE NUT 6 mm	1	43	TGH417351	COOLING FAN	1	79	TGH410925	POCKER ARM PIVOT	2
8	TGH418025	GOVERNOR ARM BOLT	1	44	TGH417300	FLYWHEEL	1	80	TGH410950	PIVOT ADJUSTING NUT	2
9	TGH411700	LOCK PIN 10 mm	1	45	TGH411450	OIL SEALφ35×φ52×7	2	81	TGH410900	VALVE ROCKER ARM	2
10	TGH411750	PLAIN WASHER 6×15mm	2	46	TGH411425	RADIAL BALL BEARING 6205	2	82	TGH410875	PIVOT BOLT (8 mm)	2
11	TGH411726	GOVERNOR ARM SHAFT	1	47	TGH421400	CRANK CASE	1	83	TGH410775	PUSH ROD GUIDE PLATE	1
12	TGH416750	CLIP, FUEL HOSE/φ8.0	2	48	TGH411475	DRAIN PLUG WASHER 12 mm	2	84	TGH410725	VALVE RIOTATOR	1
13	TGH416777	FUEL TUBE (EPA) φ4.5×8.5	1	49	TGH411500	DRAIN PLUG BOLT	2	85	TGH410676	IN. VALVE SPRING RETAINER	1
14	TGH416778	FUEL HOSE CARB/φ5.0×10.0	1	50	TGH422300	CRANKSHAFT COMP	1	86	TGH410675	EX. VALVE SPRING RETAINER	1
15	TGH416751	CLIP, FUEL HOSE CARB/φ9.0	2	51	TGS911051	FLAT KEY 4.78×35	1	87	TGH410600	VALVE SPRING	2
16	TGH416950	ROLL-OVER VALVE	1	52	TGH412026	PACKING GOVERNOR	1	88	TGH420800	SEAL, VALVE	1
17	TGG311852	PIPE	1	53	TGH411775	DOWEL PIN 8×14	2	89	TGH410150	FLANGE BOLT 8×58	4
18	TGH414176	CLIP	1	54	TGH411950	CRANKCASE COVER	1	90	TGH420075	HEAD COMP., CYLINDER	1
19	TGH416805	FUEL TANK CAP	1	55	TGH412002	OIL FILTER CAP	2	91	TGH410175	SPARK PLUG F8RTC	1
20	TGH417075	FUEL CAP TETHER	1	56	TGH411975	FLANGE BOLT 8×28	6	92	TGH420627	IN VALVE	1
21	TGH416850	FUEL FILTER	1	57	TGS410252	FLANGE BOLT 6×25	2	93	TGH420652	EX. VALVE	1
22	TGH416502	FUEL TANK ASSY.	1	58	TGH417375	INGITION GOIL ASSY.	1	94	TGH410050	PIN DOWEL φ10×φ12×16	2
23	TGS210075	FLANGE NUT 6MM	2	59	TGH422875	PISTON RING ASSY.	1	95	TGH420029	CYLINDER SEALING PAD	1
24	TGH416875	FUEL TANK RUBBER BLANKET	2	60	TGH422800	PISTON	1	96	TGH410850	ROD PUSH	2
25	TGS410256	FLANGE BOLT M6×30	1	61	TGH412825	PIN PISTON	1	97	TGH410825	VALVE LIFTER	2
26	TGH414025	SIDE PLATE	1	62	TGH412850	PISTON PIN CLIP 18 mm	2	98	TGS410232	FLANGE BOLT 6×10	2
27	TGS410242	FLANGE BOLT 6×16	1	63	TGH421051	CAMSHAFT	1	99	TGH414050	SHROUD	1
28	TGH411550	OIL PROTECTOR	1	64	TGH432775	CONNECTING ROD	1	100	TGH415900	MUFFLER CAP	1
29	TGS410232	FLANGE BOLT 6×10	1	65	TGS410242	FLANGE BOLT 6×16	2	101	TGH415803	MUFFLER	1
30	TGH414150	NYLON TIE	2	66	TGH411525	OIL SENSOR	1	102	TGH415826	MUFFLER GASKET	1
31	TGH411650	WASHER 6×13mm	1	67	TGS210075	FLANGE NUT 6mm	2	103	TGH410100	EXHAUST BOLT STUD	2
32	TGH411575	ADJUSTING GEAR ASSY.	1	68	TGH415302	SNOWENGINE AIR CLEANER/EPA	1	104	TGS610615	WASHER 8 mm	2
33	TGH411625	ADJUSTING GEAR SHAFT	1	69	TGH414525	GASKET, CARBURETOR	1	105	TGS110036	FLANGE NUT 8 mm	2
34	TGH411600	SLIDER GOVERNOR	1	70	TGH410325	HOSE, BREATHER, 85mm	1				
35	TGS410240	FLANGE BOLT 6×16	3	71	TGH424500	CARBURETOR ASSY.	1				
36	TGH413600	RECOIL STARTER ASSY.	1	72	TGH414576	GASKET, CARBURETOR/SPACER	1				

● TR236

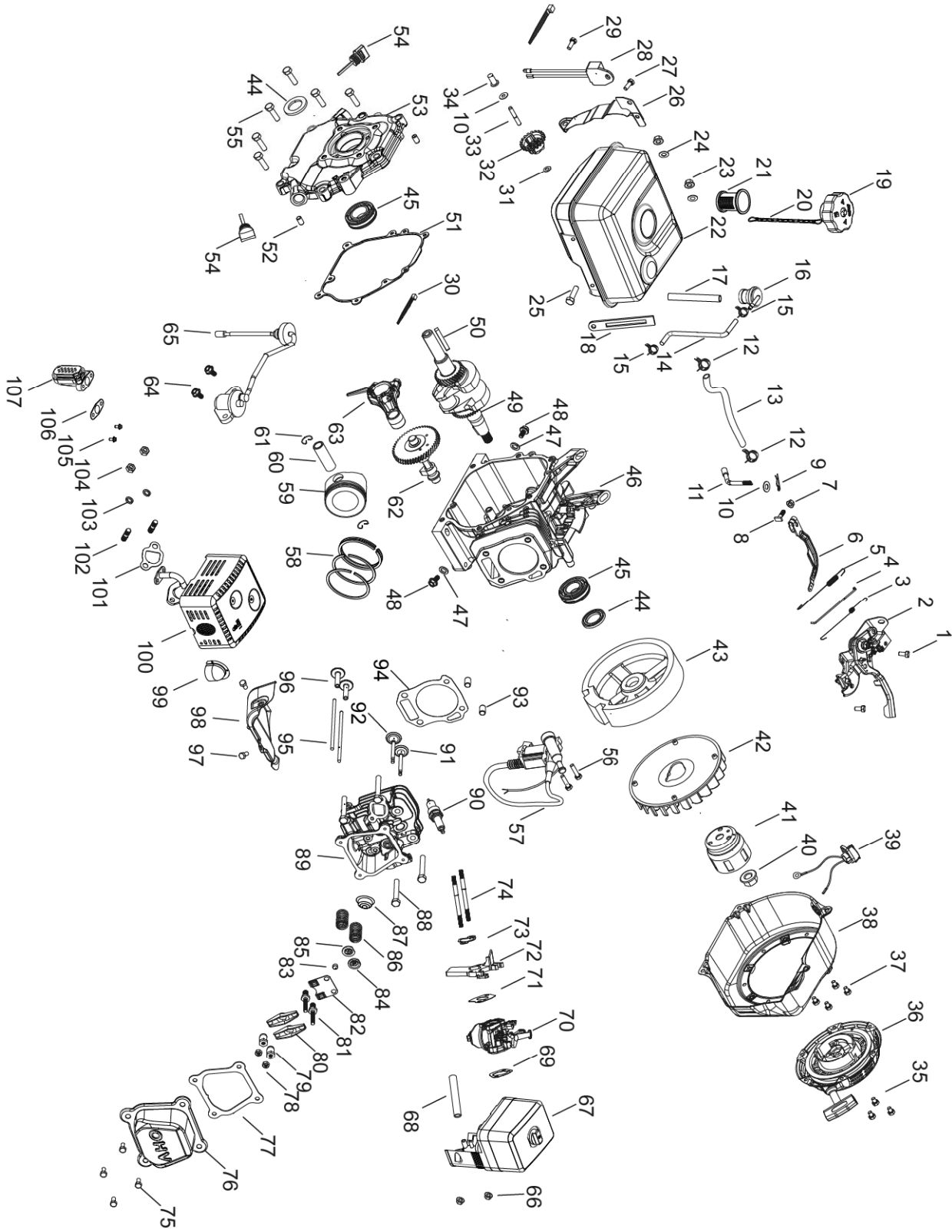

● TR236 Parts List

NO.	PART NO.	DESCRIPTION	QTY	NO.	PART NO.	DESCRIPTION	QTY	NO.	PART NO.	DESCRIPTION	QTY
1	TGS410236	FLANGE BOLT 6×12	2	37	TGS410236	FLANGE BOLT 6×12	4	73	TGH414626	GASKET, SPACER/CYLINDER HEAD	1
2	TGH417900	CONTROL ASSY.	1	38	TGH443800	FAN COVER COMP	1	74	TGH410126	INTAKE BOLT STUD(6×112)	2
3	TGH417975	GOVERNOR SPRING(GOVERNOR ROD)	1	39	TGH414100	ENGINE STOP SWITCH ASSY.	1	75	TGS410242	FLANGE BOLT 6×16	4
4	TGH417925	GOVERNOR ROD	1	40	TGH417325	SPECIAL NUT M16×1.5	1	76	TGH410200	HEAD COVER COMP	1
5	TGH417951	GOVERNOR SPRING(GOVERNOR)	1	41	TGH444000	STARTER PULLEY	1	77	TGH410225	GASKET, HEAD COVER	1
6	TGH418000	GOVERNOR ARM	1	42	TGH447350	COOLING FAN	1	78	TGH410925	POCKER ARM PIVOT	2
7	TGS210075	FLANGE NUT 6 mm	1	43	TGH417300	FLYWHEEL	1	79	TGH410950	PIVOT ADJUSTING NUT	2
8	TGH418025	GOVERNOR ARM BOLT	1	44	TGH411450	OIL SEALφ35×φ52×7	2	80	TGH410900	VALVE ROCKER ARM	2
9	TGH411700	LOCK PIN 10 mm	1	45	TGH411425	RADIAL BALL BEARING 6205	2	81	TGH410875	PIVOT BOLT (8 mm)	2
10	TGH411750	PLAIN WASHER 6×15mm	2	46	TGH441400	CRANK CASE	1	82	TGH410775	PUSH ROD GUIDE PLATE	1
11	TGH411726	GOVERNOR ARM SHAFT	1	47	TGH411475	DRAIN PLUG WASHER 12 mm	2	83	TGH410725	VALVE RIOTATOR	1
12	TGH416750	CLIP, FUEL HOSE/φ8.0	2	48	TGH411500	DRAIN PLUG BOLT	2	84	TGH410676	IN, VALVE SPRING RETAINER	1
13	TGH416777	FUEL TUBE (EPA) φ4.5×8.5	1	49	TGH432300	CRANKSHAFT COMP	1	85	TGH410675	EX. VALVE SPRING RETAINER	1
14	TGH416778	FUEL HOSE CARB/φ5.0×10.0	1	50	TGS911051	FLAT KEY 4.78×35	1	86	TGH410600	VALVE SPRING	2
15	TGH416751	CLIP, FUEL HOSE CARB/φ9.0	2	51	TGH432026	PACKING GOVERNOR	1	87	TGH410800	SEAL, VALVE	1
16	TGH416950	ROLL-OVER VALVE	1	52	TGH411775	DOWEL PIN 8×14	2	88	TGH410150	FLANGE BOLT 8×58	4
17	TGG311852	PIPE	1	53	TGH431950	CRANKCASE COVER	1	89	TGH440075	HEAD COMP., CYLINDER	1
18	TGH414176	CLIP	1	54	TGH412002	OIL FILTER CAP	2	90	TGH410175	SPARK PLUG F6RTC	1
19	TGH416805	FUEL TANK CAP	1	55	TGH411975	FLANGE BOLT 8×28	7	91	TGH420627	IN VALVE	1
20	TGH417075	FUEL CAP TETHER	1	56	TGS410252	FLANGE BOLT 6×25	2	92	TGH420652	EX. VALVE	1
21	TGH416850	FUEL FILTER	1	57	TGH417375	INGITION GOIL ASSY.	1	93	TGH410050	PIN DOWEL φ10×φ12×16	2
22	TGH416502	FUEL TANK ASSY.	1	58	TGH442875	PISTON RING ASSY.	1	94	TGH440026	CYLINDER SEALING PAD	1
23	TGS210075	FLANGE NUT 6MM	2	59	TGH442800	PISTON	1	95	TGH410850	ROD PUSH	2
24	TGH416875	FUEL TANK RUBBER BLANKET	2	60	TGH412825	PIN PISTON	1	96	TGH410825	VALVE LIFTER	2
25	TGS410256	FLANGE BOLT M6×30	1	61	TGH412850	PISTON PIN CLIP 18 mm	2	97	TGS410232	FLANGE BOLT 6×10	2
26	TGH414025	SIDE PLATE	1	62	TGH441050	CAMSHAFT	1	98	TGH444050	SHROUD	1
27	TGS410242	FLANGE BOLT 6×16	1	63	TGH432775	CONNECTING ROD	1	99	TGH415900	MUFFLER CAP	1
28	TGH411550	OIL PROTECTOR	1	64	TGS410242	FLANGE BOLT 6×16	2	100	TGH445800	MUFFLER WITH CATALYZER	1
29	TGS410232	FLANGE BOLT 6×10	1	65	TGH411525	Oil SENSOR	1	101	TGH415826	MUFFLER GASKET	1
30	TGH414150	NYLON TIE	2	66	TGS210075	FLANGE NUT 6mm	2	102	TGH410100	EXHAUST BOLT STUD	2
31	TGH411650	WASHER 6×13mm	1	67	TGH415302	SNOWENGINE AIR CLEANER/EPA	1	103	TGS610615	WASHER 8 mm	2
32	TGH411575	ADJUSTING GEAR ASSY.	1	68	TGH410325	HOSE, BREATHER, 85mm	1	104	TGS110036	FLANGE NUT 8 mm	2
33	TGH411625	ADJUSTING GEAR SHAFT	1	69	TGH414525	GASKET, CARBURETOR	1	105	TGS410235	FLANGE BOLT 6×12	2
34	TGH411600	SLIDER GOVERNOR	1	70	TGH444500	CARBURETOR ASSY.	1	106	TGH446025	SAI VALVE GASKET	1
35	TGS410225	FLANGE BOLT 6×8	3	71	TGH414576	GASKET, CARBURETOR/SPACER	1	107	TGH446000	SAI VALVE	1
36	TGH413600	RECOIL STARTER ASSY.	1	72	TGH414600	CARBURETOR SPACER	1				

● TR306

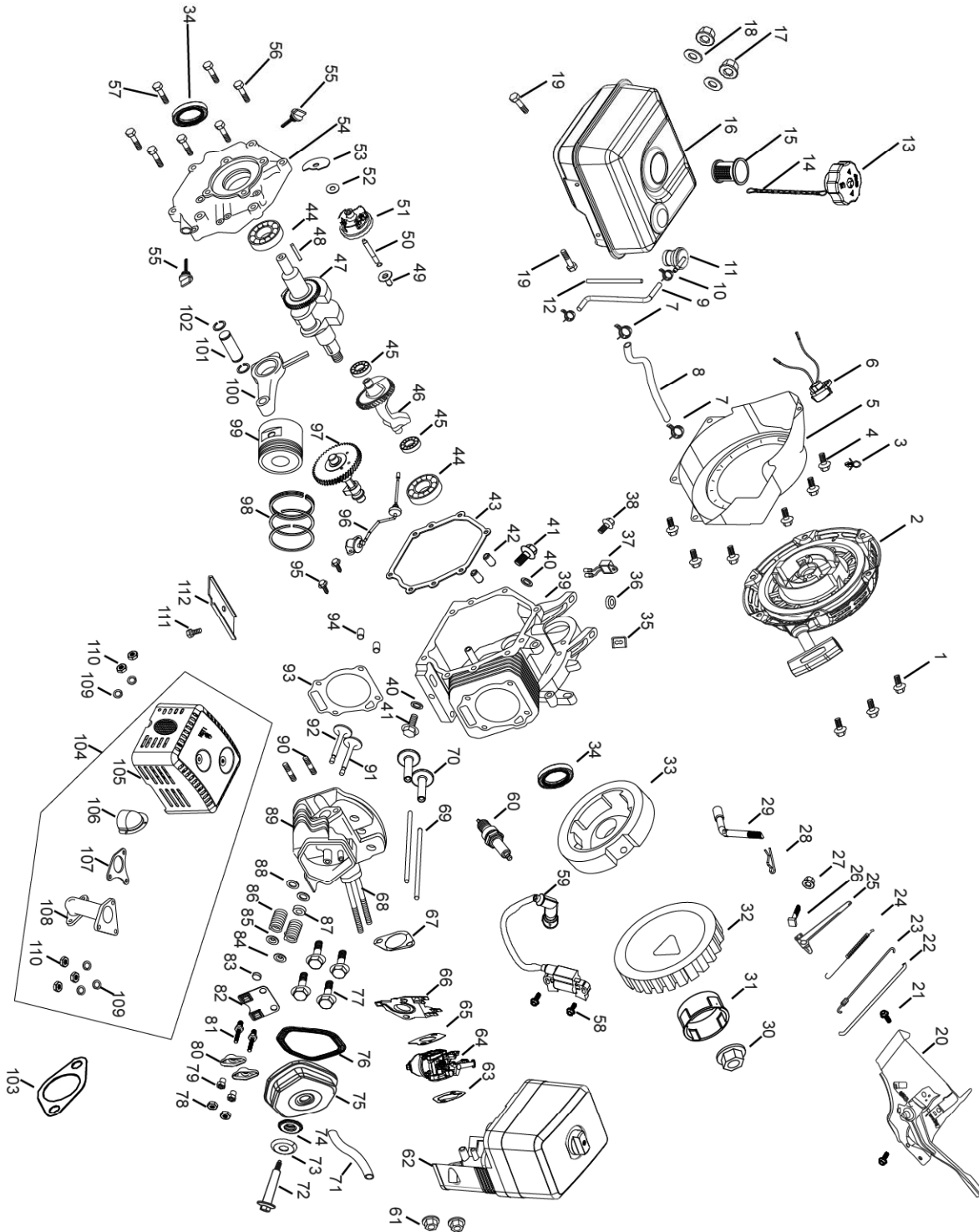

● TR306 Parts List

NO.	PART NO.	DESCRIPTION	QTY	NO.	PART NO.	DESCRIPTION	QTY	NO.	PART NO.	DESCRIPTION	QTY
1	TGS410225	FLANGE BOLT 6×8	3	39	TGH541400	CRANK CASE	1	77	TGH620150	FLANGE BOLT M10×80	4
2	TGH523600	RECOIL STARTER ASSY.	1	40	TGH621475	DRAIN PLUG WASHER 12 mm	2	78	TGH410925	POCKER ARM PIVOT	2
3	TGH414175	STOP SWITCH CORD HOLDER	1	41	TGH621500	DRAIN PLUG BOLT	2	79	TGH410950	PIVOT ADJUSTING NUT	2
4	TGS410236	FLANGE BOLT 6×12	5	42	TGH621775	DOWEL PIN 8×14	2	80	TGH620900	VALVE ROCKER ARM	2
5	TGH523800	FAN COVER COMP	1	43	TGH542026	PACKING GOVERNOR	1	81	TGH620875	PIVOT BOLT (8 mm)	2
6	TGH414100	ENGINE STOP SWITCH ASSY.	1	44	TGH521425	RADIAL BALL BEARING 6206	2	82	TGH520775	PUSH ROD GUIDE PLATE	1
7	TGH416750	CLIP, FUEL HOSE/φ8.0	2	45	TGH621425	RADIAL BALL BEARING 6202	2	83	TGH620725	VALVE RIOTATOR	1
8	TGH416777	FUEL TUBE (EPA) φ4.5×8.5	1	46	TGH541075	BALANCE SHAFT	1	84	TGH620675	IN, VALVE SPRING RETAINER	1
9	TGH416778	FUEL HOSE CARB/φ5.0×10.0	1	47	TGH542300	CRANKSHAFT COMP	1	85	TGH620676	EX VALVE SPRING RETAINER	1
10	TGH416751	CLIP, FUEL HOSE CARB/φ9.0	2	48	TGS911060	FLAT KEY 6.3×50	1	86	TGH540600	VALVE SPRING	2
11	TGH416950	ROLL-OVER VALVE	1	49	TGH621600	SLIDER GOVERNOR	1	87	TGH620800	SEAL, VALVE	1
12	TGG311852	PIPE	1	50	TGH621625	ADJUSTING GEAR SHAFT	1	88	TGH620700	VALVE SEAT	2
13	TGH416805	FUEL TANK CAP	1	51	TGH621575	ADJUSTING GEAR ASSY.	1	89	TGH540075	HEAD COMP., CYLINDER	1
14	TGH417075	FUEL CAP TETHER	1	52	TGH411750	PLAIN WASHER 6×15mm	1	90	TGH620101	EXHAUST BOLT STUD	2
15	TGH416850	FUEL FILTER	1	53	TGH541651	SHIELDED WASHER	1	91	TGH540625	IN VALVE	1
16	TGH626503	FUEL TANK ASSY.	1	54	TGH541950	CRANKCASE COVER	1	92	TGH540650	EX VALVE	1
17	TGS210081	FLANGE NUT8MM	2	55	TGH542000	OIL FILTER CAP	2	93	TGH540025	CYLINDER SEALING PAD	1
18	TGH626875	FUEL TANK RUBBER BLANKET	2	56	TGH521976	FLANGE BOLT 8×35	6	94	TGH620050	PIN DOWEL φ12×20	2
19	TGS410301	FLANGE BOLT 8×28	2	57	TGH621976	FLANGE BOLT 8×40	1	95	TGS410242	FLANGE BOLT 6×16	2
20	TGH527900	CONTROL ASSY.	1	58	TGS410252	FLANGE BOLT 6×25	2	96	TGH621525	Oil SENSOR	1
21	TGS410236	FLANGE BOLT 6×12	2	59	TGH627375	INGITON GOIL ASSY.	1	97	TGH541050	CAMSHAFT	1
22	TGH527925	GOVERNOR ROD	1	60	TGH410175	SPARK PLUG F8RTC	1	98	TGH542875	PISTON RING ASSY.	1
23	TGH627975	GOVERNOR SPRING(GOVERNOR ROD)	1	61	TGS210075	FLANGE NUT 6mm	2	99	TGH542800	PISTON	1
24	TGH547950	GOVERNOR SPRING(GOVERNOR)	1	62	TGH525301	SNOW ENGINE AIR CLEANER/EPA	1	100	TGH522775	CONNECTING ROD	1
25	TGH528000	GOVERNOR ARM	1	63	TGH624525	GASKET, CARBURETOR	1	101	TGH522825	PIN PISTON	1
26	TGH418025	GOVERNOR ARM BOLT	1	64	TGH544500	CARBURETOR ASSY.	1	102	TGH412850	PISTON PIN CLIP 18 mm	2
27	TGS210075	FLANGE NUT 6 mm	1	65	TGH524576	GASKET, CARBURETOR/SPACER	1	103	TGH625826	MUFFLER GASKET	1
28	TGH621700	LOCK PIN 10 mm	1	66	TGH524600	CARBURETOR SPACER	1	104	TGH525804	MUFFLER ASSY.	1
29	TGH541725	GOVERNOR ARM SHAFT	1	67	TGH524626	GASKET, SPACER/CYLINDER HEAD	1	105	TGH525804	MUFFLER	1
30	TGH627325	SPECIAL NUT M16×1.5	1	68	TGH520126	INTAKE BOLT STUD(M8×125)	2	106	TGH625900	MUFFLER CAP	1
31	TGH524000	STARTER PULLEY	1	69	TGH520850	ROD PUSH	2	107	TGH625875	GASKET,MUFFLER TUBE	1
32	TGH527350	COOLING FAN	1	70	TGH620825	VALVE LIFTER	2	108	TGH625850	MUFFLER TUBE	1
33	TGH547300	FLYWHEEL	1	71	TGH620325	HOSE, BREATHER, 85mm	1	109	TGS610615	WASHER 8 mm	5
34	TGH521450	OIL SEALφ35×φ52×7	2	72	TGH620250	BOLT, VALVE COVER	1	110	TGS110036	FLANGE NUT 8 mm	5
35	TGH624075	WIRE GROMMET	1	73	TGH620275	WASHER	1	111	TGS410232	FLANGE BOLT 6×10	1
36	TGH621675	OIL SEALφ8×φ14×5	1	74	TGH620300	O-RING	1	112	TGH524050	SHROUD	1
37	TGH411550	OIL PROTECTOR	1	75	TGH620200	HEAD COVER COMP	1				
38	TGS410232	FLANGE BOLT 6×10	1	76	TGH620225	GASKET, HEAD COVER	1				

13. LIMITED WARRANTY

FULLBOAR ("We" or "Us") warrants to the original purchaser only ("You" or "Your") that the Full Boar product purchased will be free from material defects in both materials and workmanship, normal wear and tear excepted, for a period of two years from date of purchase. The foregoing warranty is valid only if the installation and use of the product is strictly in accordance with product instructions. There are no other warranties, express or implied, including the warranty of merchantability or fitness for a particular purpose. If the product does not comply with this limited warranty, Your sole and exclusive remedy is that We will, at our sole option and within a commercially reasonable time, either replace or repair the product or product component without charge to You or refund the purchase price (less shipping). This limited warranty is not transferable.

Limitations on the Warranty

This limited warranty does not cover: (a) normal wear and tear; (b) damage through abuse, neglect, misuse, or as a result of any accident or in any other manner; (c) damage from misapplication, overloading, or improper installation; (d) improper maintenance and repair; and (e) product alteration in any manner by anyone other than Us, with the sole exception of alterations made pursuant to product instructions and in a workmanlike manner.

Obligations of Purchaser

You must retain Your product purchase receipt to verify date of purchase and that You are the original purchaser. To make a warranty claim, contact Us at (888) 533-2999, identify the product by make and model number, and follow the claim instructions that will be provided. The product and the purchase receipt must be provided to Us in order to process Your warranty claim. Any returned product that is replaced or refunded by Us becomes our property. You will be responsible for return shipping costs or costs related to Your return visit to a retail store.

Remedy Limits

Product replacement, repair or a refund of the purchase price is Your sole remedy under this limited warranty or any other warranty related to the product. We shall not be liable for: service or labor charges or damage to Your property incurred in removing or replacing the product; any damages, including, without limitation, damages to tangible personal property or personal injury, related to Your improper use, installation, or maintenance of the product or product component; or any indirect, incidental or consequential damages of any kind for any reason.

Assumption of Risk

You acknowledge and agree that any use of the product for any purpose other than the specified use(s) stated in the product instructions is at Your own risk. Governing Law This limited warranty gives You specific legal rights, and You also may have other rights which vary from state to state. Some states do not allow limitations or exclusions on implied warranties or incidental or consequential damages, so the above limitations may not apply to You. This limited warranty is governed by the laws of the State of Minnesota, without regard to rules pertaining to conflicts of law. The state courts located in Dakota County, Minnesota shall have exclusive jurisdiction for any disputes relating to this warranty.

U.S EPA EMISSION CONTROL WARRANTY STATEMENT YOUR WARRANTY RIGHTS AND OBLIGATIONS

The U.S Environmental Protection Agency (EPA) and FULLBOAR are pleased to explain the emissions control system warranty on your 2015 and later small None-Road Spark Ignition (NRSI) engines. FULLBOAR must warrant the emissions control system on your NRSI engines for the periods of time listed below provided there has been no abuse, neglect or improper maintenance of your NRSI engines.

Your emission control system may include parts such as the carburetor, fuel tanks, fuel caps, fuel lines, the ignition system, and catalytic converter. Also included may be hoses, belts, S clamps, connectors and other emission-related assemblies.

Where a warrantable condition exists, FULLBOAR will repair your small off-road engine at no cost to you including diagnosis, parts and labor.

MANUFACTURER'S WARRANTY COVERAGE

The emissions control system is warranted for two years. If any emissions-related part on your engine is defective, the part will be repaired or replaced by FULLBOAR.

OWNER'S WARRANTY RESPONSIBILITIES

-As the NRSI ENGINE owner, you are responsible for the performance of the required maintenance listed in your owner's manual. FULLBOAR recommends that you retain all receipts covering maintenance on your NRSI ENGINE, but FULLBOAR can not deny warranty solely for the lack of receipts or for your failure to ensure the performance of all scheduled maintenance.

-As the NRSI ENGINE owner, you should however be aware that FULLBOAR may deny your warranty coverage if your NRSI ENGINE or a part has failed due to abuse, neglect, improper maintenance or unapproved modifications.

-You are responsible for presenting your NRSI ENGINE to distribution center or service center authorized by FULLBOAR as soon as the problem exists. The warranty repairs should be completed in a reasonable amount of time, not to exceed 30 days.

If you have any questions regarding your warranty coverage or how to locate a service center, you should contact FULLBOAR at:

Tell: (888) 533-2999

Email: Support@gofullboar.com

DEFECTS WARRANTY COVERAGE

FULLBOAR warrants to the ultimate purchaser and each subsequent purchaser that the small off-road engine (NRSI ENGINE) (1) has been designed, built and equipped so as to conform with all applicable regulations; and (2) is free from defects in materials and workmanship that cause the failure of a warranted part to conform with those regulations as may be applicable to the terms and conditions stated below.

(1) The warranty period begins on the date the engine is delivered to an ultimate purchaser or first placed into service. The warranty period is two years.

(2) Subject to certain conditions and exclusions as stated below, the warranty on emissions related parts is as follows:

(a) Any warranted part that is not scheduled for replacement as required maintenance in your Owner's Manual is warranted for the warranty period stated above. If the part fails during the period of warranty coverage, the part will be repaired or replaced by FULLBOAR according to Subsection (d) below. Any such part repaired or replaced under warranty will be warranted for the remainder of the period.

(b) Any warranted part that is scheduled only for regular inspection in your Owner's Manual is warranted for the warranty period stated above. Any such part repaired or replaced under warranty will be warranted for the remaining warranty period.

(c) Any warranted part that is scheduled for replacement as required maintenance in your Owner's Manual is warranted for the period of time before the first scheduled replacement date for that part. If the part fails before the first scheduled replacement, the part will be repaired or replaced by FULLBOAR according to Subsection (d) below. Any such part repaired or replaced under warranty will be warranted for the remainder of the period prior to the first scheduled replacement point for the part.

(d) Repair or replacement of any warranted part under the warranty provisions herein must be performed at a warranty station at no charge to the owner.

(e) Notwithstanding the provisions herein, warranty services or repair will be provided at all of our distribution centers that are franchised to service the subject engines.

(f) The engine owner must not be charged for diagnostic labor that leads to the determination that a warranted part is in fact defective, provided that such diagnostic work is performed at a warranty station.

(g) FULLBOAR is liable for damages to other engine components proximately caused by a failure under warranty of any warranted part.

(h) Throughout the engine warranty period stated above, FULLBOAR will maintain a supply of warranted parts sufficient to meet the expected demand for such parts.

(i) Any replacement part may be used in the performance of any warranty maintenance or repairs and must be provided without charge to the owner. Such use will not reduce the warranty obligations of FULLBOAR.

(j) Add-on or modified parts that are not exempted by the U.S EPA may not be used. The use of any non-exempted add-on or modified parts by the ultimate purchaser will be grounds for disallowing a warranty claims. FULLBOAR will not be liable to warrant failures of warranted parts caused by the use of a non-exempted add-on or modified part.

(k) The manufacturer issuing the warranty shall provide any documents that describe that manufacturer's warranty procedures or policies within five working days of request by the U.S EPA.

EMISSION WARRANTY PARTS LIST

The repair or replacement of any warranted part otherwise eligible for warranty coverage may be excluded from such warranty coverage if FULLBOAR demonstrates that the engine has been abused, neglected, or improperly maintained, and that such abuse, neglect, or improper maintenance was the direct cause of the need for repair or replacement of the part. That notwithstanding, any adjustment of a component that has a factory installed, and properly operating, adjustment limiting device is still eligible for warranty coverage. The following emissions warranty parts for each engine family list is covered.

(1) Fuel Metering System:

- (a) Gasoline carburetor assembly and its internal components
- (b) Carburetor gaskets
- (c) Fuel tank
- (d) Fuel Line
- (e) Fuel Line Fittings
- (f) Clamps

(2) Air Induction System including:

- (a) Intake pipe/manifold
- (b) Air cleaner

(3) Ignition System including:

- (a) Spark plug
- (b) Ignition coil

(4) Catalytic Muffler Assembly including:

- (a) Muffler gasket
- (b) Exhaust manifold
- (c) Catalytic converter

(5) Crankcase Breather Assembly including:

- (a) Breather connection tube.

(6) Fuel tank evaporative emissions control system including:

- (a) Purge Valves
- (b) Carbon Canister
- (c) Canister Mounting Brackets
- (d) Fuel Cap

(7) Miscellaneous items Used in Above Systems including:

- (a) Switches
 - (b) Hoses, belts, connectors, and assemblies.
- (8) Air injection system
- (a) Pulse valve