

**VENT-FREE GAS
LINEAR FIREPLACE
OWNER'S OPERATION AND
INSTALLATION MANUAL**

**BVFIL48NRT - SKU: 170576
AND
BVFIL48LRT - SKU: 170579**



**CSA/ANS Z21.11.2
2019 Unvented
Room Heaters
PFS F09-043**

⚠ WARNING: If the information in this manual is not followed exactly, a fire or explosion may result causing property damage, personal injury or loss of life.

- Do not store or use gasoline or other flammable vapors and liquids in the vicinity of this or any other appliance.
- **WHAT TO DO IF YOU SMELL GAS**
 - Do not try to light any appliance.
 - Do not touch any electrical switch; do not use any phone in your building.
 - Immediately call your gas supplier from a neighbor's phone. Follow the gas supplier's instructions.
 - If you cannot reach your gas supplier, call the fire department.
- Installation and service must be performed by a qualified installer, service agency or the gas supplier.

⚠ WARNING: This appliance is equipped for natural gas or propane gas. Field conversion is not permitted.



Questions, problems, missing parts? Before returning to your retailer, call our Customer Care department at 1-866-762-4050, 8:00 am - 4:30 pm CST, Monday through Friday or email service@bluegrassliving.com

TABLE OF CONTENTS

Safety Information.....	2	Accessory Installation.....	26
Specifications.....	4	Wiring Diagram.....	28
Product Identification.....	4	Troubleshooting.....	28
Local Codes.....	5	Replacement Parts.....	31
Qualified Installing Agency.....	5	Parts.....	32
Water Vapor: A By-Product of Unvented Room Heaters.....	5	Service Hints.....	34
Air for Combustion and Ventilation.....	6	Technical Service.....	34
Installation.....	8	Accessories.....	34
Operation.....	17	Notes.....	35
Inspecting Burners.....	23	Warranty.....	36
Care and Maintenance.....	24		

SAVE THIS BOOK

INSTALLER: Leave this manual with the appliance.

CONSUMER: Retain this manual for future reference.

This is an unvented gas-fired heater. It uses air (oxygen) from the room in which it is installed. Provisions for adequate combustion and ventilation air must be provided. Refer to *Air For Combustion and Ventilation* section on page 6 of this manual.

⚠ WARNING: FIRE, EXPLOSION AND ASPHYXIATION HAZARD

Improper adjustment, alteration, service, maintenance, or installation of this heater or its controls can cause death or serious injury.

Read and follow instructions and precautions in User's Information Manual provided with this heater.

This appliance may be installed in an aftermarket*, permanently located, manufactured (mobile) home, where not prohibited by local codes.

This appliance is only for use with the type of gas indicated on the rating plate. This appliance is not convertible for use with other gases.

* Aftermarket: Completion of sale, not for purpose of resale, from the manufacturer.

SAFETY INFORMATION

IMPORTANT: Read this owner's manual carefully and completely before trying to assemble, operate, or service this heater. Improper use of this heater can cause serious injury or death from burns, fire, explosion, electrical shock and carbon monoxide poisoning. Failure to follow these instructions will void the warranty.

Only a qualified installer, service agent, or local gas supplier may install and service this product.

This appliance is only for use with the type of gas indicated on the rating plate. This appliance is not convertible for use with other gases.

⚠ WARNING: Keep the appliance area clear and free from combustible materials, gasoline, and other flammable vapors and liquids.

⚠ DANGER: Carbon monoxide poisoning may lead to death!

CARBON MONOXIDE POISONING: Early signs of carbon monoxide poisoning resemble the flu, with headaches, dizziness or nausea. If you have these signs, the heater may not be working properly. Get fresh air at once! Have heater serviced. Some people are more affected by carbon monoxide than others. These include pregnant women, people with heart or lung disease or anemia, those under the influence of alcohol and those at high altitudes.

SAFETY INFORMATION

NATURAL AND PROPANE GAS: Natural and propane gas are odorless. An odor-making agent is added to the gas. The odor helps you detect a gas leak. However, the odor added to the gas can fade. Gas may be present even though no odor exists.

⚠ WARNING: Do not allow fans to blow directly into fireplace. Avoid any drafts that alter burner flame patterns.

⚠ WARNING: Do not use a blower insert, heat exchange insert or other accessory not approved for use with this heater.

⚠ WARNING: Due to high temperatures, the appliance should be located out of traffic and away from furniture and draperies.

⚠ WARNING: Do not place clothing or other flammable material on or near the appliance. Never place any objects in the fireplace.

⚠ WARNING: Fireplace becomes very hot when running. Keep children and adults away from hot surfaces to avoid burns or clothing ignition. Fireplace will remain hot for a time after shutdown. Allow surfaces to cool before touching.

⚠ WARNING: Carefully supervise young children when they are in the room with the heater. Toddlers, young children and others may be susceptible to accidental contact burns. A physical barrier is recommended if there are at-risk individuals in the house. To restrict access to a fireplace or stove, install an adjustable safety gate to keep toddlers, young children and other at risk individuals out of the room and away from hot surfaces.

⚠ WARNING: The fire screen or guard designed for this unvented appliance must be installed prior to operation.

1. Do not place propane supply tank(s) inside any structure. Propane supply tank(s) must be placed outdoors.
2. This heater shall not be installed in a bedroom or bathroom.
3. This heater needs fresh air ventilation to run properly. This heater has an Oxygen Depletion Sensing (ODS) safety shutoff system. The ODS shuts down the heater if not enough fresh air is available. See *Air for Combustion and Ventilation*, pages 6 and 7. If heater keeps shutting off, see *Troubleshooting*, page 30.
4. Keep all air openings in front and bottom of heater clear and free of debris. This will ensure enough air for proper combustion.
5. If heater shuts off, do not relight until you have provided fresh, outside air. If heater keeps shutting off, have it serviced.
6. Do not run heater:
 - Where flammable liquids or vapors are used or stored.
 - Under dusty conditions.
 - Outdoors.
7. Before using furniture polish, wax, carpet cleaner, or similar products, turn heater off. If heated, the vapors from these products may create a white powder residue within burner box or on adjacent walls or furniture.
8. Do not use heater if any part has been under water. Immediately call a qualified service technician to inspect the room heater and to replace any part of the control system and any gas control which has been under water.
9. Turn off and unplug heater and let cool before servicing. Only a qualified service person should service and repair heater.
10. Operating heater above elevations of 4,500 feet could cause pilot outage.
11. To prevent performance problems, do not use propane fuel tank of less than 100 lbs. capacity.
12. Do not use this heater as a wood-burning heater. Use only the logs provided with the heater.
13. To prevent sooting, follow the instructions in *Care and Maintenance*, page 24.

SAFETY INFORMATION

14. This fireplace is designed to be smokeless. If fireplace or optional logs ever appear to smoke, turn off fireplace and call a qualified service person.

Note: During initial operation, slight smoking could occur due to log curing and the fireplace burning manufacturing residues.

15. This appliance is for indoor operation, and should not be installed outdoors.

SPECIFICATIONS

	BVFIL48NRT	BVFIL48LRT
Gas Type	Natural Gas	Propane Gas
Ignition	IPI/CPI	IPI/CPI
Input Rating, Maximum	39,000 Btu/Hr	35,000 Btu/Hr
Input Rating, Minimum	25,000 Btu/Hr	27,000 Btu/Hr
Pressure Regulator Setting	3.5" W.C.	10" W.C.
Inlet Gas Pressure* (inches of water) (*for purposes of input adjustment)	Maximum 10.5"	Maximum 13"
	Minimum 7"	Minimum 11"
Heater Dimensions (WxHxD): 53" x 25.35" x 11.81"		
Carton Dimensions (WxHxD): 61.5" x 35.5" x 24"		
Fireplace Weight: 95lbs		

PRODUCT IDENTIFICATION

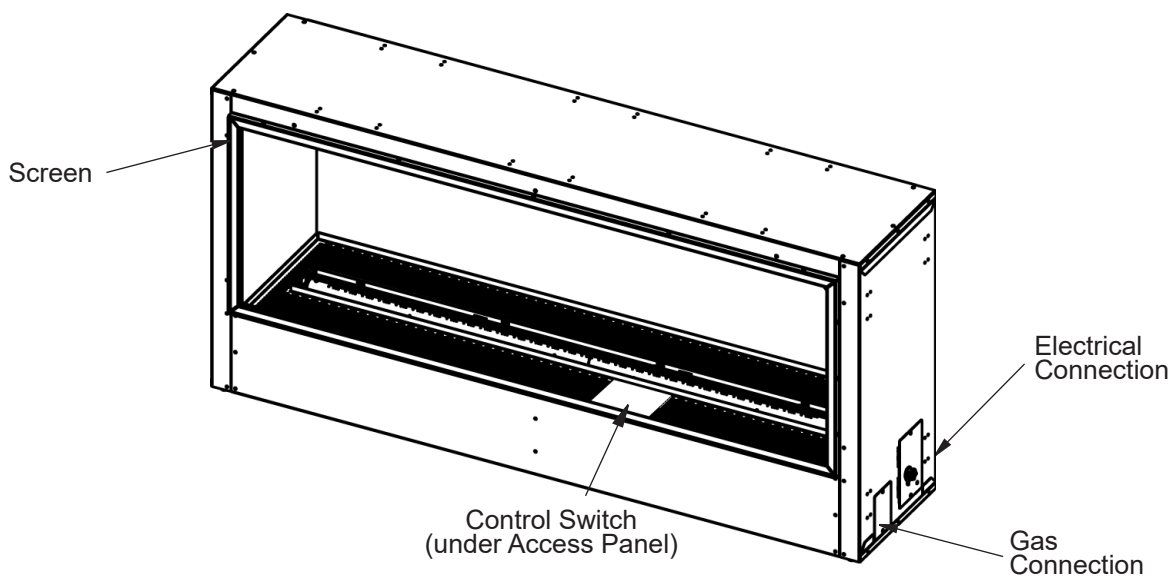

Figure 1 - Product Identification

LOCAL CODES

Install and use heater with care. Follow all local codes.

In the absence of local codes, use the latest edition of:

*The National Fuel Gas Code, ANSI Z223.1/
NFPA 54**.

*Available from:

American National Standards Institute, Inc.
25 West 43rd Street
New York, NY 10036

National Fire Protection Association, Inc.
1 Batterymarch Park
Quincy, MA 02269-9101

This heater is designed for vent-free operation. State and local codes in some areas prohibit the use of vent-free heaters.

State of Massachusetts: The installation must be made by a licensed plumber or gas fitter in the Commonwealth of Massachusetts.

Sellers of unvented propane or natural gas-fired supplemental room heaters shall provide to each purchaser a copy of 527 CMR 30 upon sale of the unit.

In the State of Massachusetts the gas cock must be a T-handle type. The State of Massachusetts requires that a flexible appliance connector cannot exceed three feet in length.

QUALIFIED INSTALLING AGENCY

Only a qualified agency should install and replace gas piping, gas utilization equipment or accessories, and repair and equipment servicing. The term "qualified agency" means any individual, firm, corporation, or company that either in person or through a representative is engaged in and is responsible for:

- a) Installing, testing, or replacing gas piping or
- b) Connecting, installing, testing, repairing, or servicing equipment; that is experienced in such work; that is familiar with all precautions required; and that has complied with all the requirements of the authority having jurisdiction.

WATER VAPOR: A BY-PRODUCT OF UNVENTED ROOM HEATERS

Water vapor is a by-product of gas combustion. An unvented room heater produces approximately one (1) ounce (30 mL) of water for every 1,000 BTUs (0.3 kW) of gas input per hour. Unvented room heaters are recommended as supplemental heat (a room) rather than a primary heat source (an entire house). In most supplemental heat applications, the water vapor does not create a problem. In most applications, the water vapor enhances the low humidity atmosphere experienced during cold weather.

The following steps will help ensure that water vapor does not become a problem.

1. Be sure the heater is sized properly for the application, including sample combustion air and circulation air.
2. If high humidity is experienced, a dehumidifier may be used to help lower the water vapor content of the air.
3. Do not use an unvented room heater as the primary heat source.

AIR FOR COMBUSTION AND VENTILATION

⚠ WARNING: This heater shall not be installed in a confined space or unusually tight construction unless provisions are made for adequate combustion and ventilation air. Read the following instructions to ensure proper fresh air for this and other fuel-burning appliances in your home.

Today's homes are built more energy efficient than ever. New materials, increased insulation and new construction methods help reduce heat loss in homes. Homeowners weather-strip and caulk around windows and doors to keep the cold air out and the warm air in. During heating months, homeowners want their homes as airtight as possible. While it is good to make your home energy efficient, your home needs to breathe. Fresh air must enter your home. All fuel-burning appliances need fresh air for proper combustion and ventilation. Exhaust fans, fireplaces, clothes dryers and fuel-burning appliances draw air from the house to operate.

You must provide adequate fresh air for these appliances. This will ensure proper venting of vented fuel-burning appliances.

⚠ WARNING: This heater shall not be installed in a room or space unless the required volume of indoor combustion air is provided by the method described in the *National Fuel Gas Code, ANSI Z223.1/NFPA 54*, the *International Fuel Gas Code*, or applicable local codes.

⚠ WARNING: If the area in which the heater may be operated does not meet the required volume for indoor combustion air, combustion and ventilation air shall be provided by one of the methods described in the *National Fuel Gas Code, ANSI Z223.1/NFPA 54*, the *International Fuel Gas Code*, or applicable local codes.

VENTILATION AIR

Ventilation Air From Inside Building

This fresh air would come from an adjoining unconfined space. When ventilating to an adjoining unconfined space, you must provide two permanent openings: one within 12" of the ceiling and one within 12" of the floor on the wall connecting the two spaces (see options 1 and 2, Figure 2).

You can also remove a door into an adjoining room (see option 3, Figure 2). Follow the *National Fuel Gas Code, ANSI Z223.1/NFPA 54, Air for Combustion and Ventilation* for required size of ventilation grills or ducts.

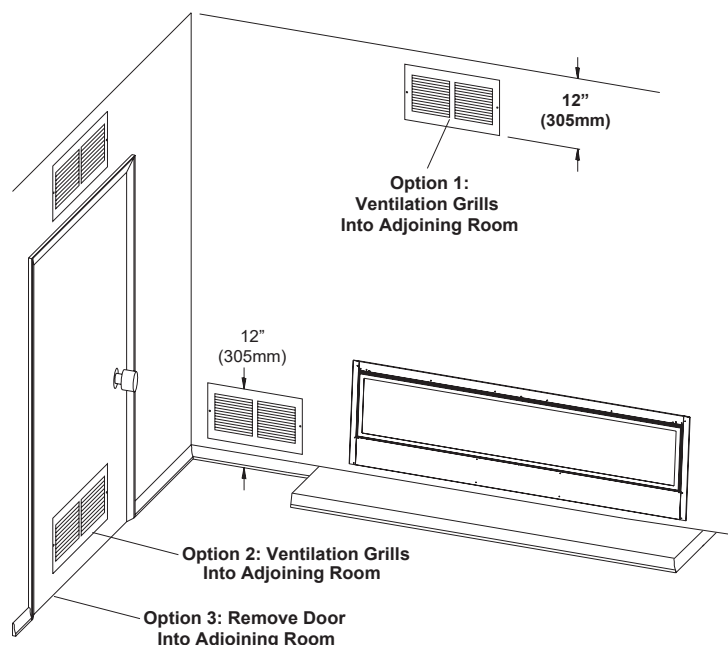

Figure 2 - Ventilation Air from Inside Building

AIR FOR COMBUSTION AND VENTILATION

Ventilation Air From Outdoors

Provide extra fresh air by using ventilation grills or ducts. You must provide two permanent openings: one within 12" of the ceiling and one within 12" of the floor. Connect these items directly to the outdoors or spaces open to the outdoors (See Figure 3). These spaces include attics and crawl spaces. Follow the *National Fuel Gas Code, ANSI Z223.1/ NFPA 54, Air for Combustion and Ventilation* for required size of ventilation grills or ducts.

IMPORTANT: Do not provide openings for inlet or outlet air into attic if attic has a thermostat-controlled power vent. Heated air entering the attic will activate the power vent. Rework worksheet, adding the space of the adjoining unconfined space. The combined spaces must have enough fresh air to supply all appliances in both spaces.

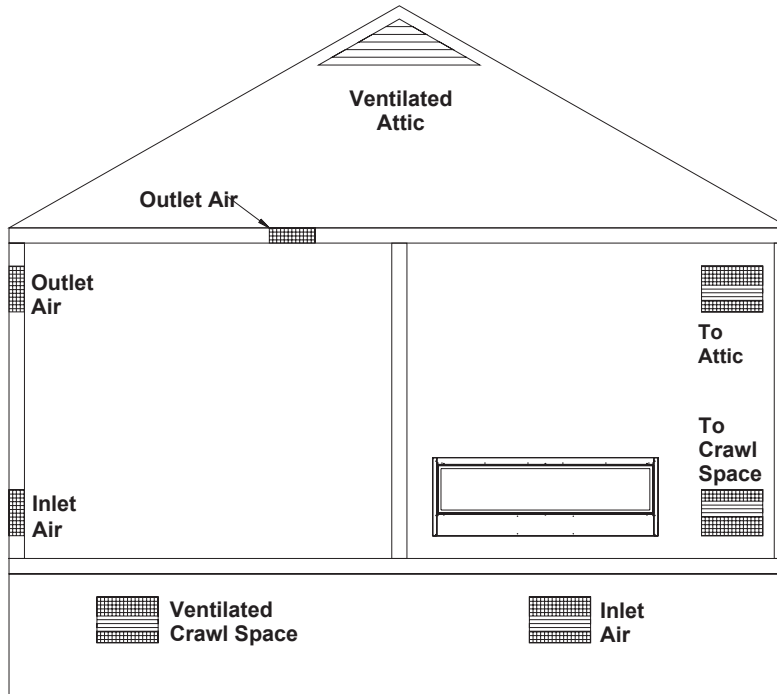

Figure 3 - Ventilation Air from Outdoors

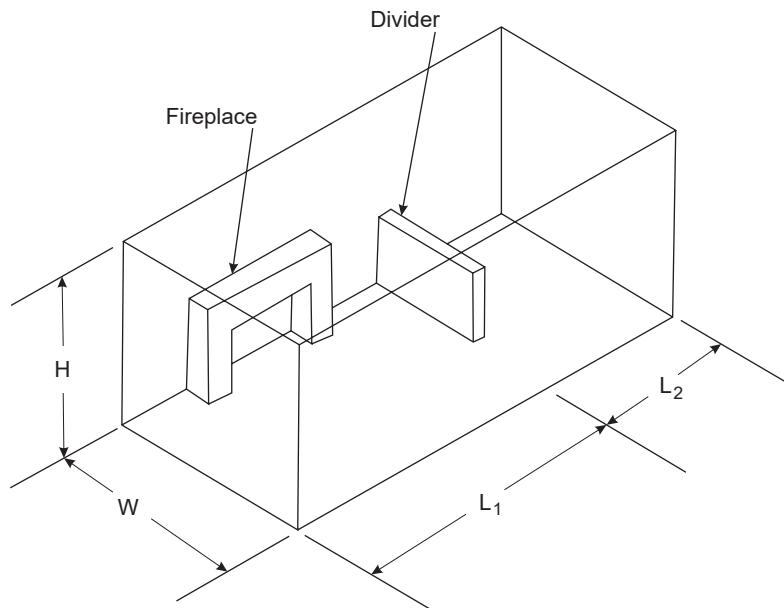

Figure 4 - Example of a Large Room With 1/2 Wall Divider

INSTALLATION

NOTICE: This heater is intended for use as supplemental heat. Use this heater along with your primary heating system. Do not install this heater as your primary heat source. If you have a central heating system, you may run the system's circulating blower while using heater. This will help circulate the heat throughout the house. In the event of a power outage, you can use this heater as a heat source.

⚠ WARNING: A qualified service person must install heater. Follow all local codes.

⚠ WARNING: Never install the heater:

- in a bedroom or bathroom
- in a recreational vehicle
- where curtains, furniture, clothing, or other flammable objects are less than 42" from the front, top, or sides of the heater
- in high traffic areas
- in windy or drafty areas
- outdoors

⚠ CAUTION: This heater creates warm air currents. These currents move heat to wall surfaces next to heater. Installing heater next to vinyl or cloth wall coverings or operating heater where impurities (such as tobacco smoke, aromatic candles, cleaning fluids, oil or kerosene lamps, etc.) in the air exist, may cause walls to discolor.

NOTICE: Do not use standard drywall as it is not rated as a Non-Combustible. Material in shaded area must be Non-Combustible Hardboard or Cement Board, Certified to ASTM E-136.

⚠ IMPORTANT

The steps in Figure 5A and Figure 5B, page 9, are for a "Clean Face" installation. This type of installation will allow for finishing around the fireplace face with high-temperature paint. See Figures 6A and 6B, page 9, for installing the fireplace for a "Flush Face" installation.

IMPORTANT: Vent-free heaters add moisture to the air. Although this is beneficial, installing heater in rooms without enough ventilation air may cause mildew to form from too much moisture. See *Air for Combustion and Ventilation*, pages 6 and 7.

CHECK GAS TYPE

Be sure your gas supply is right for your heater. Otherwise, call dealer where you bought the heater for proper type heater.

CLEARANCES TO COMBUSTIBLES

⚠ WARNING: You must maintain the minimum clearances shown in Figures 5A, 5B, 6A and 6B. If you can, provide greater clearances from floor, ceiling, and joining wall. Measure from outermost point of heater.

Minimum Wall and Ceiling Clearances

- A. Clearances from outermost point of fireplace opening to any combustible side wall should not be less than 6". See Figure 5A and Figure 6A (page 9).
- B. Clearances from the heater to the ceiling should not be less than 36".

Note: When heater is installed directly on carpeting, vinyl or other combustible material, other than wood flooring, the heater must be installed on a metal or wood panel extending the full width and depth of the heater.

"CLEAN FACE" INSTALLATION

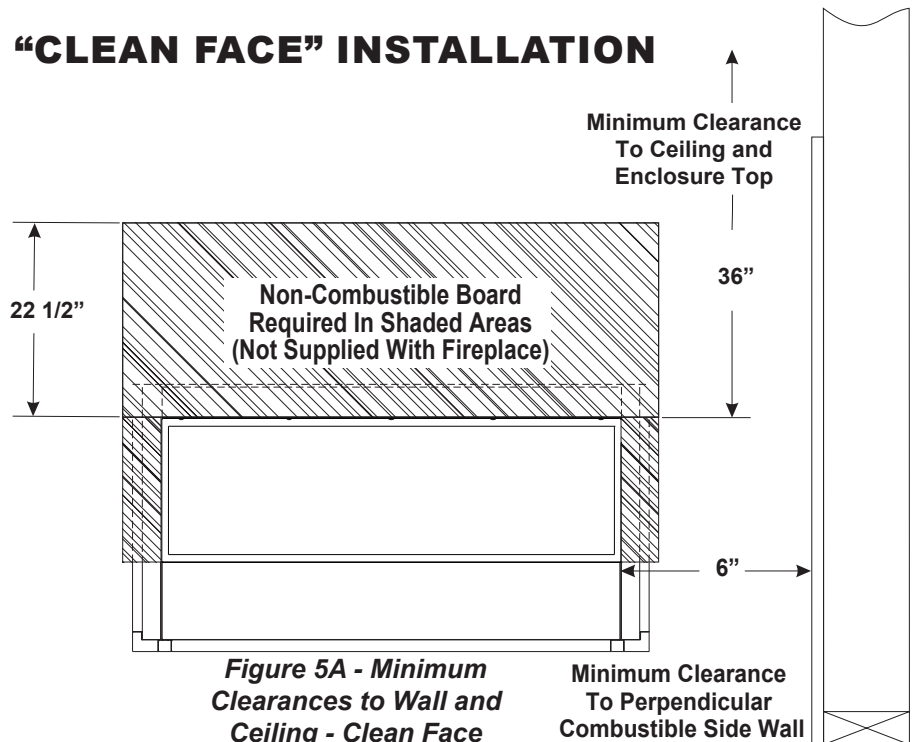

INSTALLATION

“FLUSH FACE” INSTALLATION

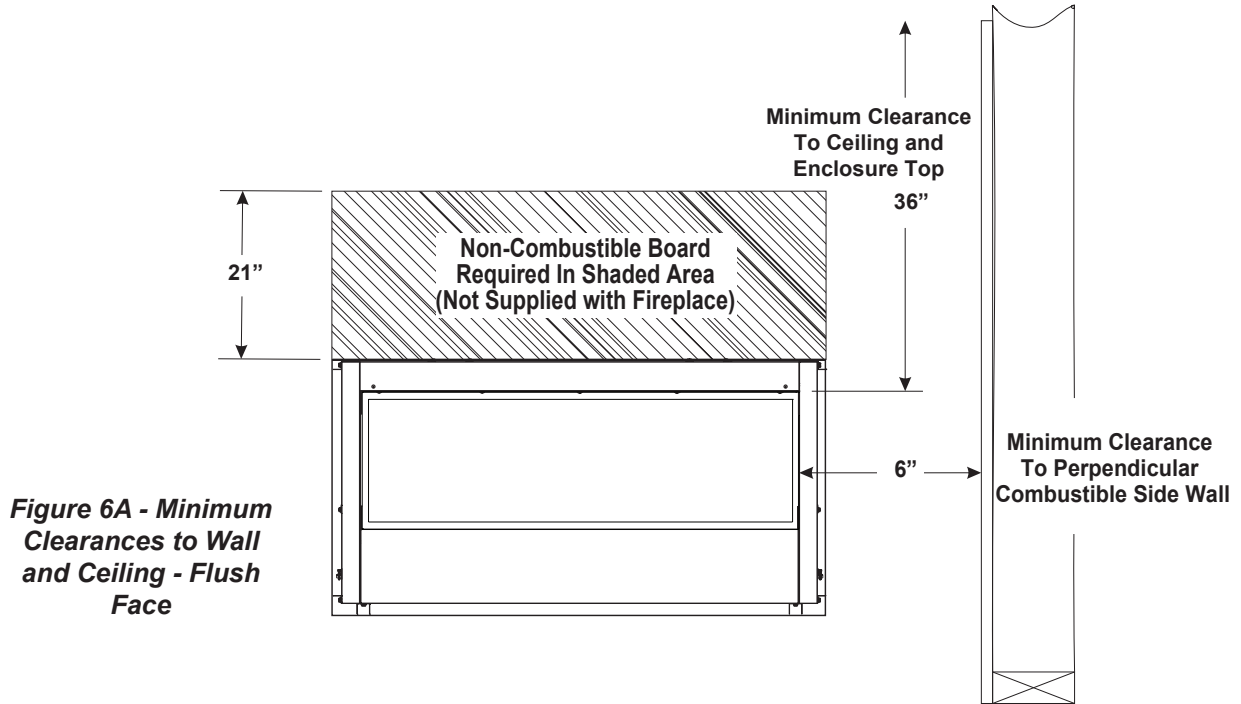

“CLEAN FACE” INSTALLATION

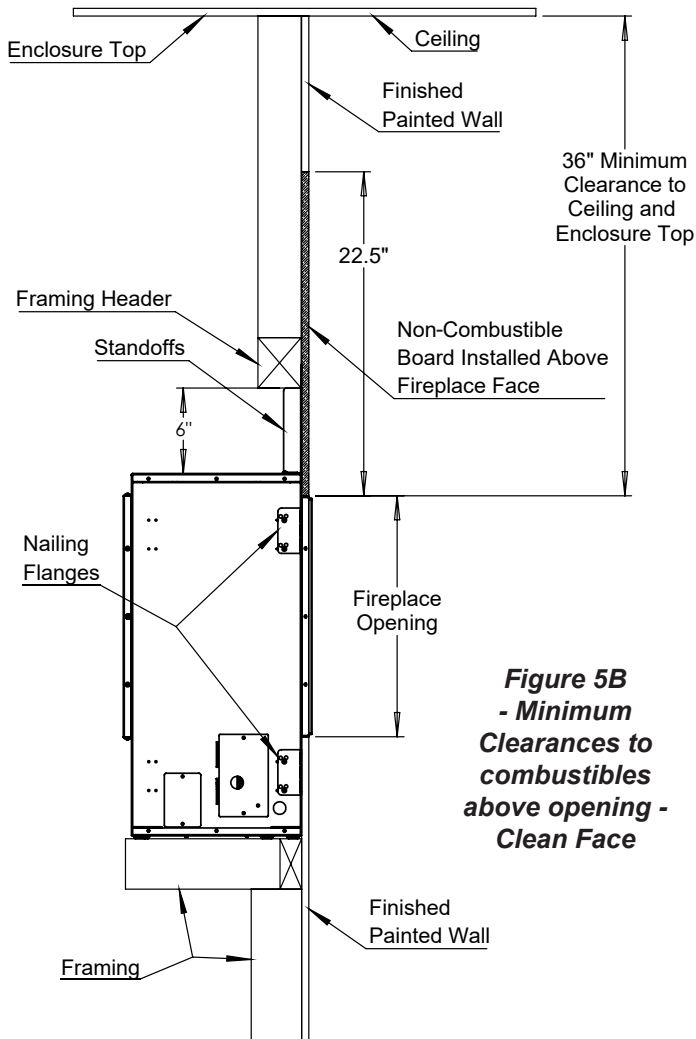

“FLUSH FACE” INSTALLATION

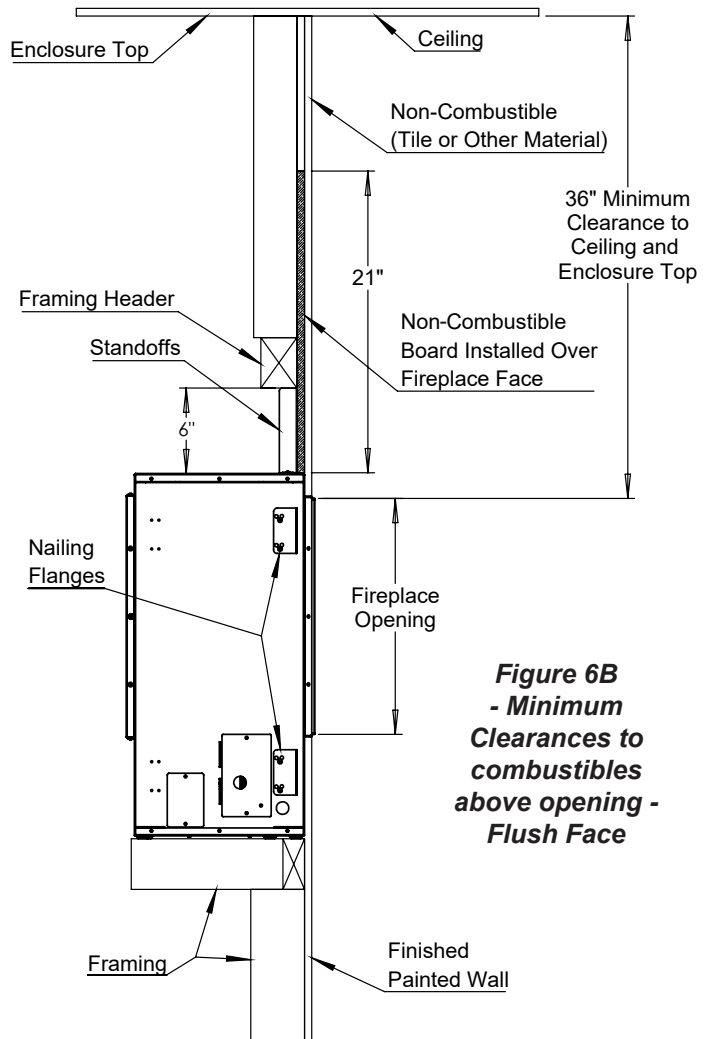

INSTALLATION

MOUNTING HOLES FOR NAILING FLANGES AND STANDOFF BRACKETS

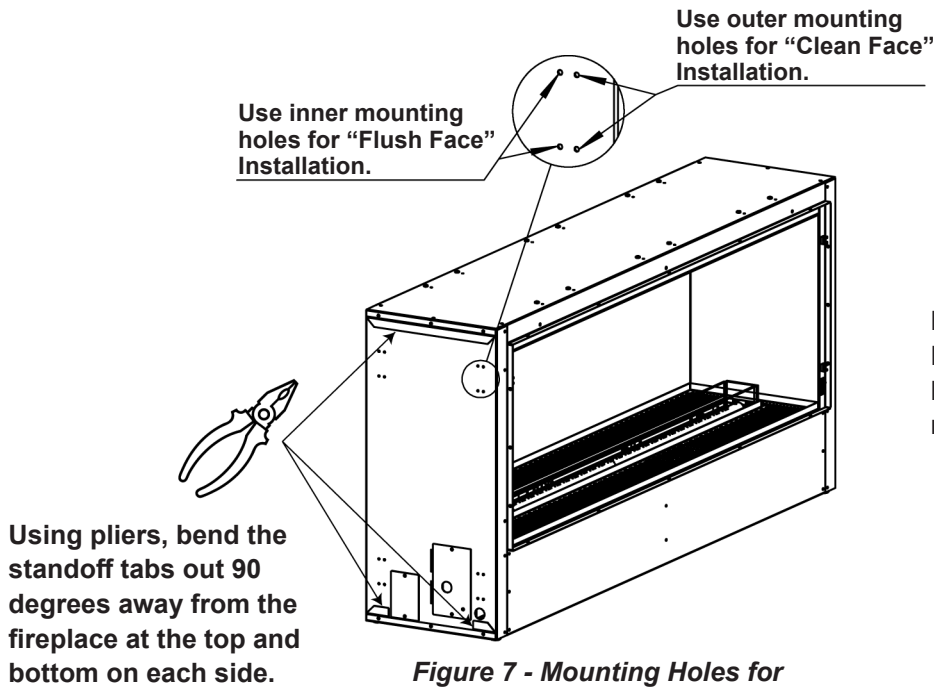
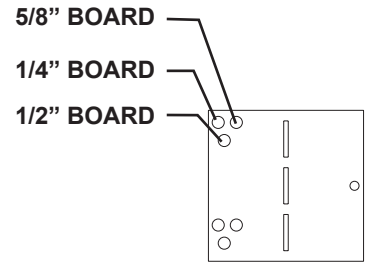

Figure 7 - Mounting Holes for Flanges and Standoff Brackets



Install the four Side Mounting Brackets, then bend to 90 Degrees to mount Fireplace

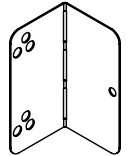

Figure 8 - Nailing Flange Holes for Non-Combustible Board Size

PRODUCT DIMENSIONS

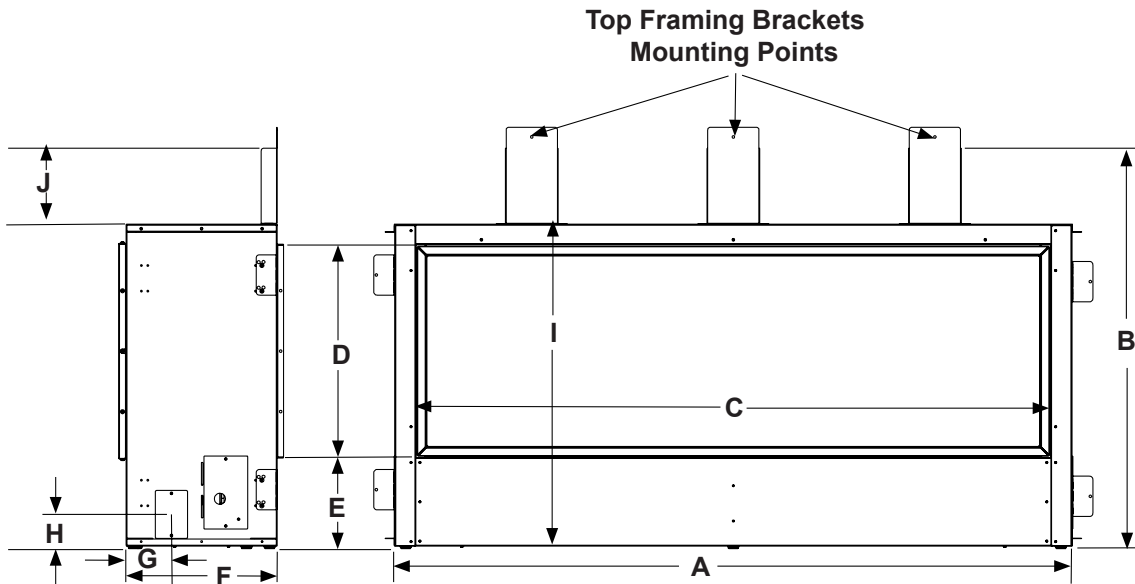

Figure 9 - Product Dimensions

MODEL	A	B	C	D	E	F	G	H	I	J
BVFIL48NRT	53"	31.25"	48"	16.7"	7.06"	11.81"	3.9"	2.31"	25.35"	5.44"
BVFIL48LRT	53"	31.25"	48"	16.7"	7.06"	11.81"	3.9"	2.31"	25.35"	5.44"

INSTALLATION

MANTEL CLEARANCES

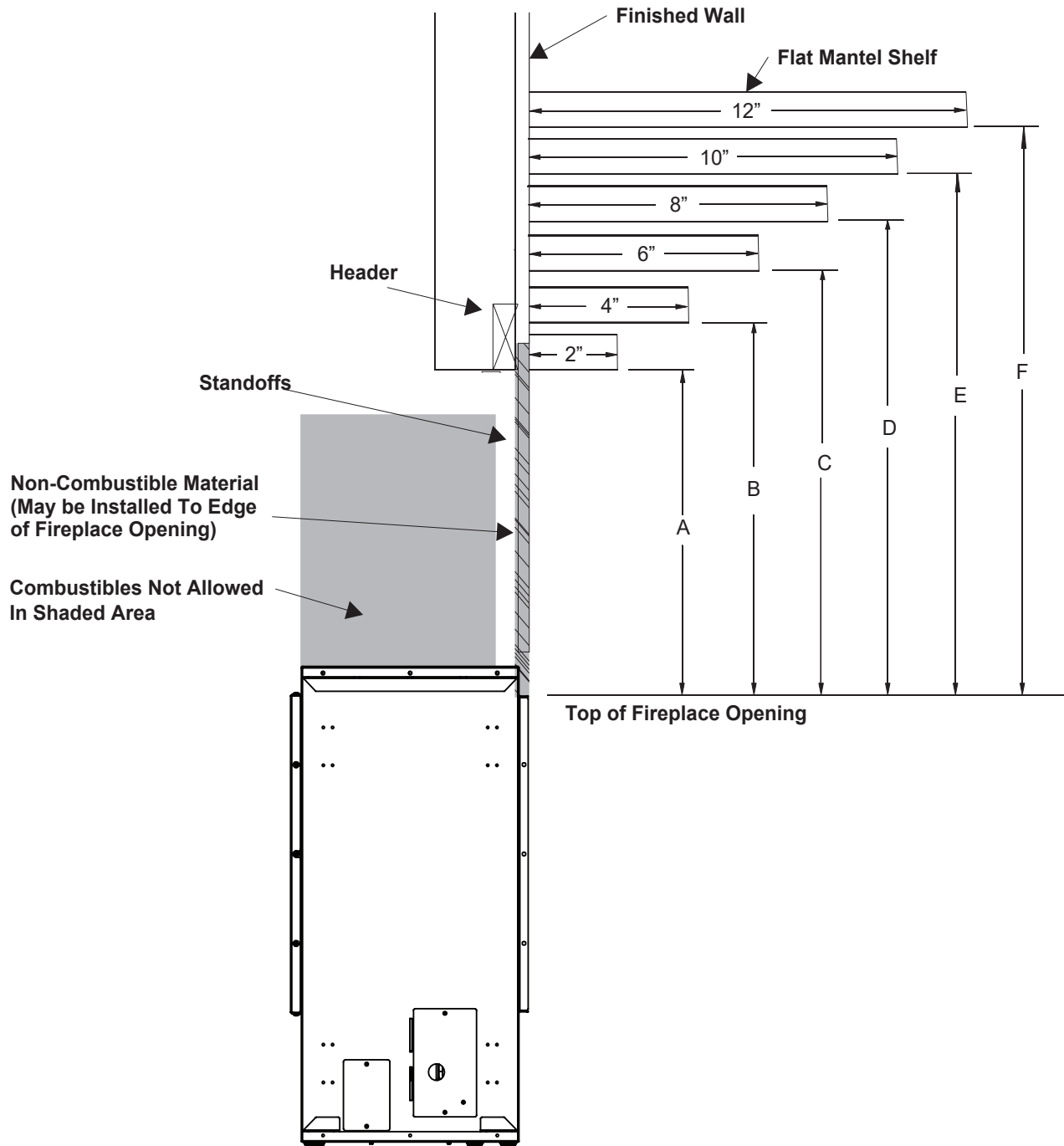

Figure 10 - Mantel Clearances

MODEL	A	B	C	D	E	F
BVFIL48NRT	18"	20"	22"	24"	26"	28"
BVFIL48LRT	18"	20"	22"	24"	26"	28"

INSTALLATION

CONTROL SWITCH/BATTERY BOX AND REMOTE HANDSET

Battery Installation and Programming

1. Follow Steps 1-3 shown in Figure 11.

Install the 4 AA batteries into the Control Switch battery bay. Batteries are a backup for times when AC Power is unavailable.

Note the polarity of the batteries and insert batteries into the battery bay as indicated on the battery cover (+/-).

2. Place the 3-position slide switch in the REMOTE position.

3. Insert a pencil point or the end of a paper clip into the hole marked "PRG" on the receiver front cover; the receiver will beep three times to indicate that it is ready to synchronize with a transmitter.

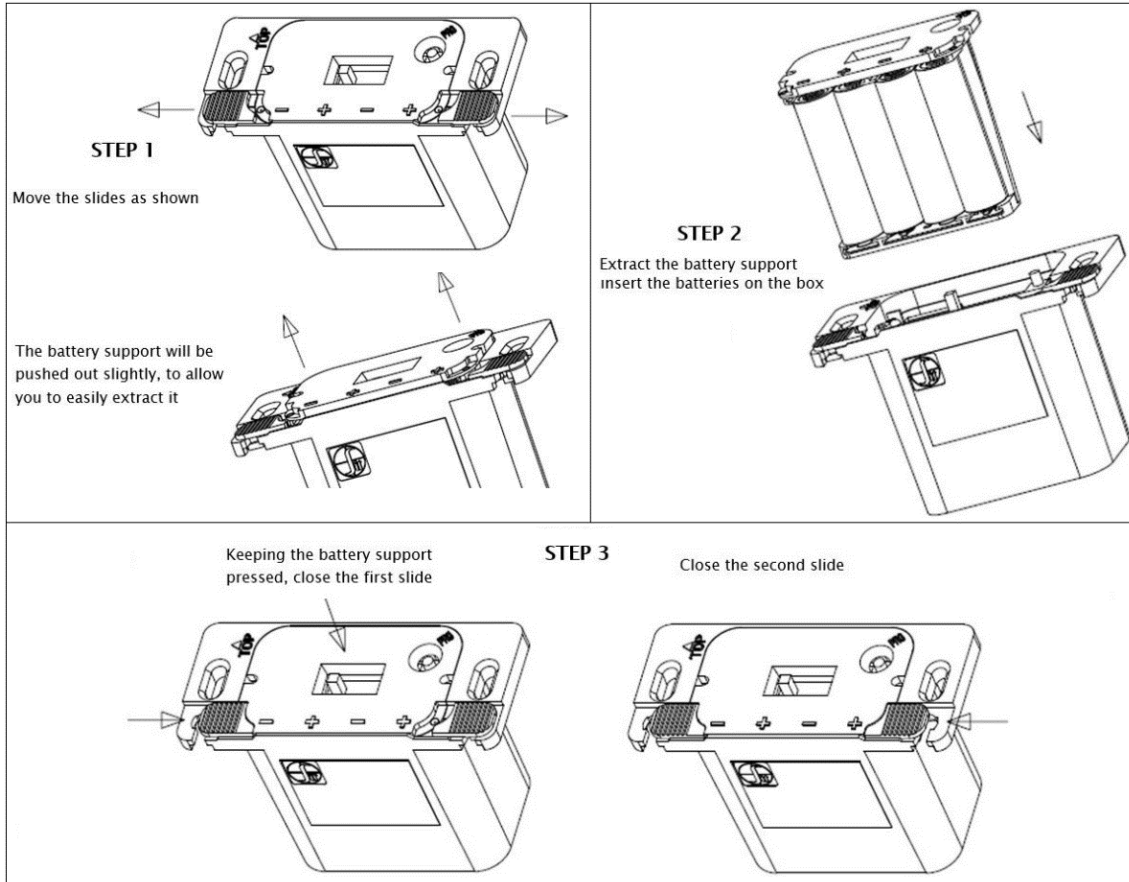

Figure 11 - Control Switch Battery Bay

4. Install the (3) AAA batteries in the Handset as shown in Figure 12. Battery bay is located on the base of the back of the Handset as indicated (+/-).

5. Press the ON button on the transmitter. The receiver will beep four times to indicate the transmitters command is accepted. The system is now initialized.



Figure 12 - Handset Battery Bay

INSTALLATION

EXTERNALLY LOCATED CONTROL SWITCH/ BATTERY BOX

The Control Switch/Battery Box may be relocated from the fireplace into an adjacent wall, as shown in Figure 13, using the provided Old Work Box. Due to the type of installation labor, this should be done at the time of the fireplace installation. This will allow MANUAL operation of the burner without the need to remove the screen and media tray. This will also enable the operator to replace the system backup batteries more easily. Relocating the Control Switch/Battery Box will not have any effect on Remote Control operation. The supplied Wire Harness Extension is 10' long. The Control Switch/Battery Box will need to be removed from its location within the fireplace.

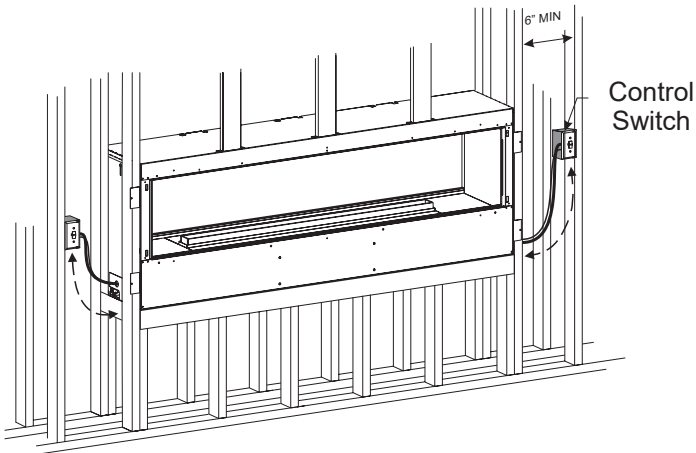

Figure 13 - Remote location of Control Switch

Connect the supplied Wiring Extension Cable to the 6-pin connector on the Control Switch/Backup Battery Box as shown in Figure 14. Connect the other end of the Extension Cable to the Fireplace Wiring Harness at the location from which the Control Switch was removed in the fireplace.

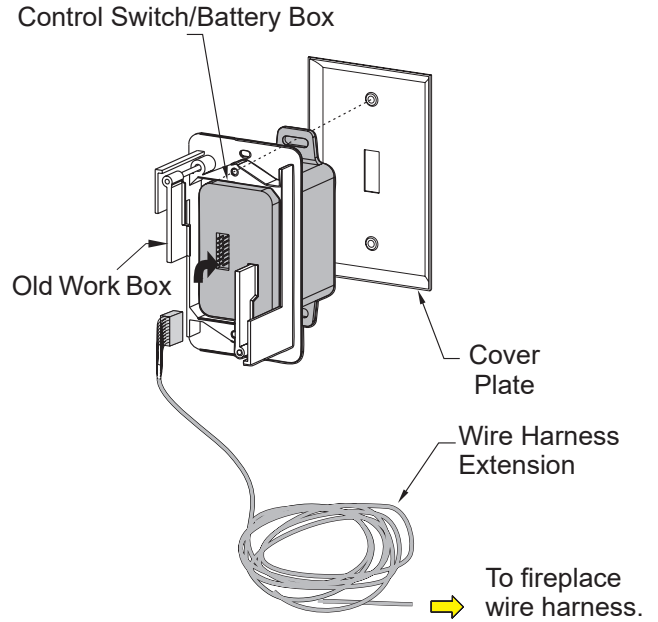

Figure 14 - Wire Extension Connection

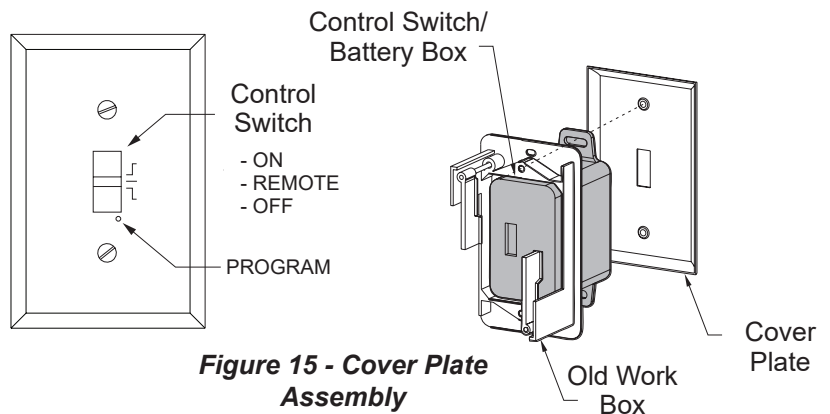
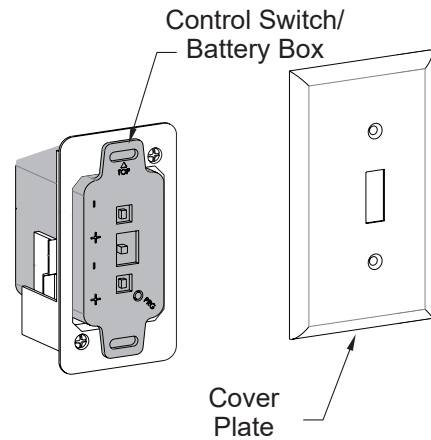

Figure 15 - Cover Plate Assembly

INSTALLATION

⚠ WARNING: Do not allow any combustible materials to overlap the firebox front.

⚠ WARNING: Do not allow combustible or noncombustible materials to cover any necessary openings like louvered slots.

Built-in installation of this fireplace involves installing fireplace into a framed-in enclosure. This makes the front of the fireplace flush with the wall. If installing a built-in mantel above the fireplace, you must follow the clearances shown in Figure 10, page 11.

NOTICE: Surface temperatures of adjacent walls and mantels become hot during operation. Walls and mantels above the fireplace may become hot to the touch. If installed properly, these temperatures meet the requirement of the national product standard. Follow all minimum clearances shown in this manual (see Figure 5A, page 8; Figure 5B, 6A, and 6B, page 9; and Figure 10, page 11).

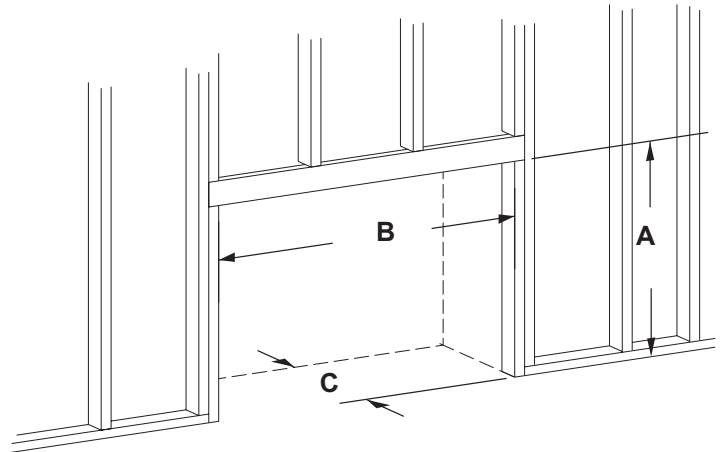

Figure 16 - Rough Opening in a Normal Wall

Note: If installing as a Two-Sided Fireplace refer to Accessory Installation - L2S48-1, page 26. Follow those framing dimensions and specific instructions and return to this point.

Rough Opening Dimensions

MODEL	A	B	C	D**	E**	F**
BVFIL48NRT	31.3/8"	54.1/2"	13" *	55.19"	78.05"	39.03"
BVFIL48LRT	31 3/8"	54.1/2"	13" *	55.19"	78.05"	39.03"

* 12.5" when installing Fireplace Assembly in a "Flush Face" finished condition.

** Refer to Figure 18, Page 15, for Corner Installation.

FIREPLACE ROUGH OPENING

1. Frame in rough opening.
 - This fireplace is designed to be mounted on a solid, flat surface or raised platform.
 - Use dimensions shown in Figure 16 for a conventional rough opening.
 - Use Figure 17 for a raised (elevated) installation. Provide adequate support to the bottom of the fireplace.
 - Use dimensions "A", "B" and "D", "E", and "F" shown in Figure 18, page 15, for corner rough opening. Be sure to provide gas line and electrical power for fireplace assembly.
2. See *Electrical Supply Connection* on page 15 for details on electrical requirements and to verify gas and electrical lines are correct for fireplace installation.
3. Refer to *Connecting to Gas Supply* pages 16 and 17 for details on gas connection.

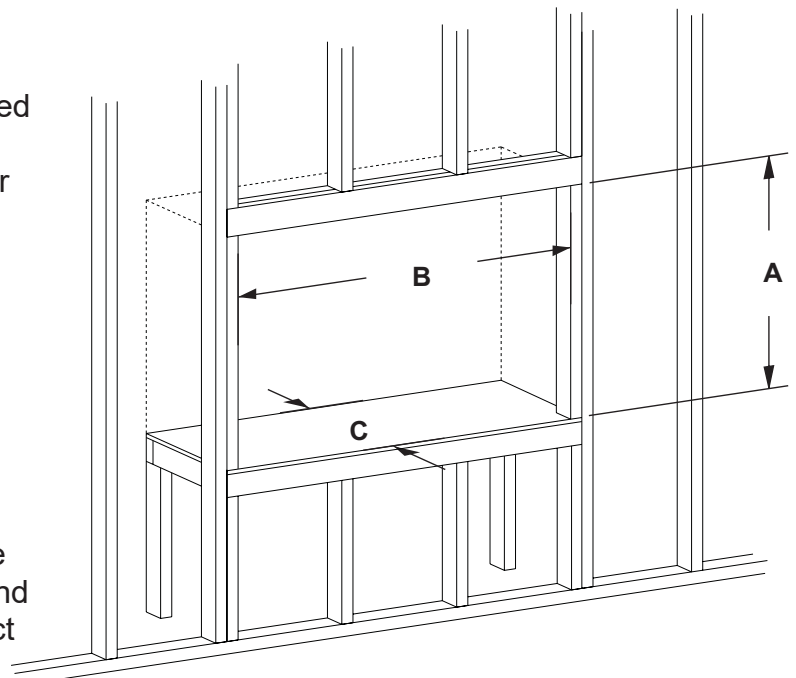

Figure 17 - Raised Installation Rough Opening in a Normal Wall

INSTALLATION

CORNER INSTALLATION

Installation may also be done in a corner.

Figure 18 shows the minimum dimensions for an installation in a corner. Refer to the chart *Rough Opening Dimensions* (page 14).

A raised installation may also be made in a corner with the hearth elevated as shown in Figure 17 (page 14) *Raised Installation*.

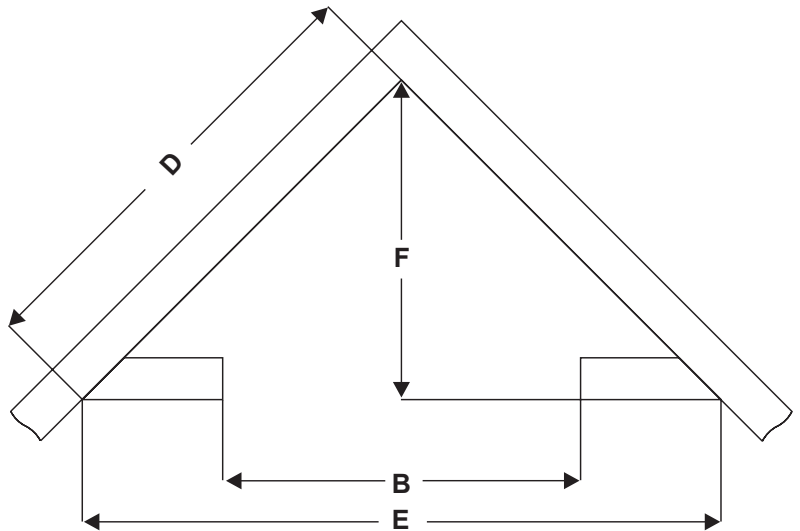

Figure 18 - Rough Opening for a Corner Installation

Electrical Supply Connection

⚠ WARNING: All wiring or electrical connections must be done by a qualified electrician and be done in compliance with all local, city, and state building codes. Before making the electrical connection, make sure the main power supply is disconnected. The fireplace, when installed, must be electrically grounded in accordance with local codes, or in the absence of local codes, with the National Electrical Code ANSI/NFPA70 (latest edition).

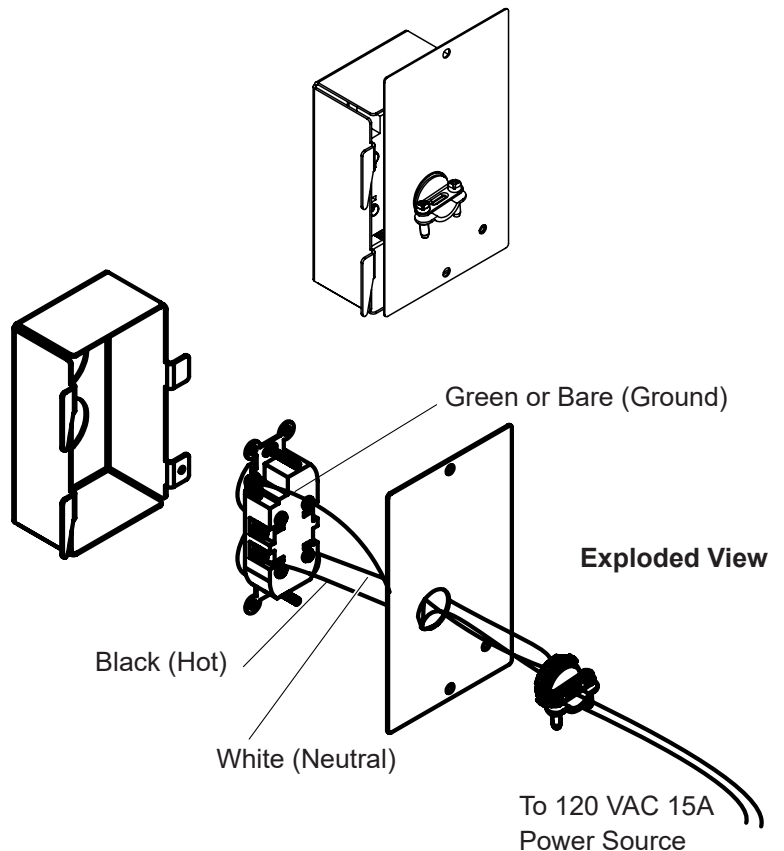
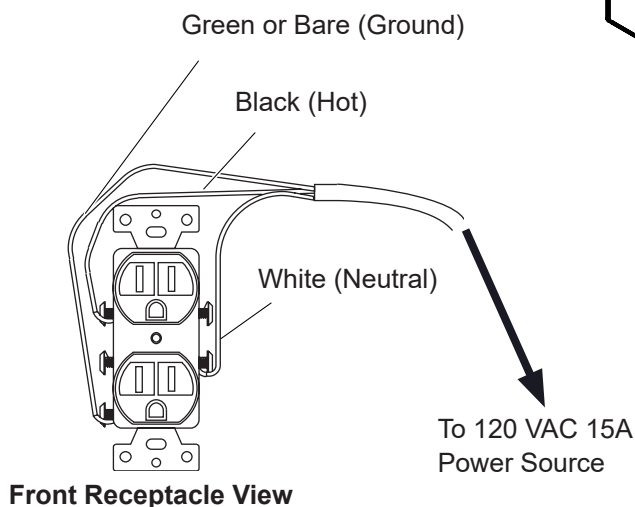

Figure 19 - Junction Box Installation

INSTALLATION

CONNECTING TO GAS SUPPLY

⚠ WARNING: A qualified service technician must connect heater to gas supply. Follow all local codes.

⚠ WARNING: This appliance requires a 3/8" NPT (National Pipe Thread) brass inlet connection to the pressure regulator.

⚠ WARNING: For natural gas, never connect heater to private (non-utility) gas wells. This gas is commonly known as wellhead gas.

⚠ WARNING: Do not overtighten gas connections.

⚠ CAUTION: Use only new, black iron or steel pipe. Internally tinned copper tubing may be used in certain areas. Check your local codes. Use pipe of 1/2" diameter or greater to allow proper gas volume to heater. If pipe is too small, undue loss of pressure will occur.

⚠ CAUTION: For natural gas, check your gas line pressure before connecting heater to gas line. Gas line pressure must be no greater than 10.5" of water. If gas line pressure is higher, heater regulator damage could occur.

⚠ CAUTION: For propane gas, never connect heater directly to the gas supply. This heater requires an external regulator (not supplied). Install the external regulator between the heater and gas supply. Gas supplier provides external regulator for natural gas. The installer provides the external regulator for propane gas.

⚠ CAUTION: Use pipe joint sealant that is resistant to gas (Propane or Natural Gas).

Before installing heater, make sure you have the items listed below:

- external regulator for propane unit only (supplied by installer)
- piping (check local codes)
- sealant (resistant to natural gas and propane gas)
- equipment shutoff valve*
- test gauge connection*
- sediment trap
- tee joint

- pipe wrench
- flexible gas hose (check local codes)
- 3/8" NPT brass fitting

* A CSA design-certified equipment shutoff valve with 1/8" NPT tap is an acceptable alternative to test gauge connection. Purchase the optional CSA design certified equipment shutoff valve from your dealer.

Typical Inlet Pipe Diameters

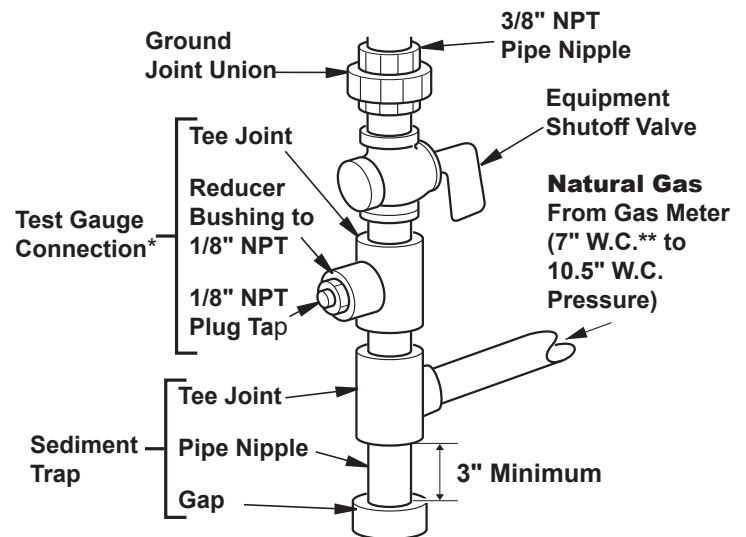

Figure 20A - Gas Connection

Use 3/8" black iron pipe or greater. Installation must include an equipment shutoff valve, union, and plugged 1/8" NPT tap. Locate NPT tap within reach for test gauge hook up. NPT tap must be upstream from heater (see Figure 20A).

IMPORTANT: Install an equipment shutoff valve in an accessible location. The equipment shutoff valve is for turning on or shutting off the gas to the appliance.

Apply pipe joint sealant lightly to male threads. This will prevent excess sealant from going into pipe. Excess sealant in pipe could result in clogged heater valves.

For propane installations, the installer must supply an external regulator. The external regulator will reduce incoming gas pressure. You must reduce incoming gas pressure to between 11" and 13" of water column. If you do not reduce incoming gas pressure, heater regulator damage could occur.

INSTALLATION

Install external regulator with the vent pointing down as shown in Figure 21. Pointing the vent down protects it from freezing rain or sleet.

For both gas types, install sediment trap in supply line as shown in Figure 20A (page 16). Place sediment trap where it is within reach for cleaning. Place sediment trap where trapped matter is not likely to freeze. A sediment trap traps moisture and contaminants. This keeps them from going into heater controls. If sediment trap is not installed or is installed wrong, heater may not run properly.

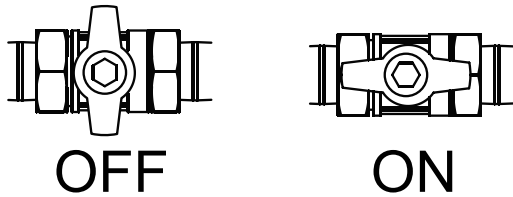

Figure 20B - Equipment Shutoff Valve

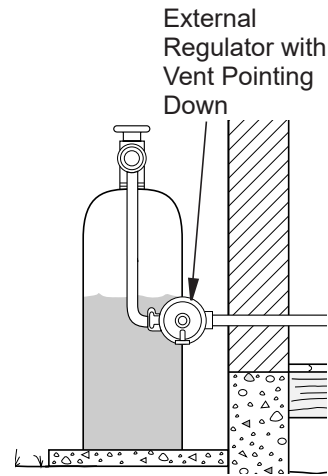

Figure 21 - External Regulator with Vent Pointing Down

CHECKING GAS CONNECTIONS

⚠ WARNING: Test all gas piping and connections for leaks after installing or servicing. Correct all leaks at once.

⚠ WARNING: Never use an open flame to check for a leak. Apply a noncorrosive leak detection fluid to all joints. If bubbles form, there is a leak. Correct all leaks at once.

PRESSURE TESTING GAS SUPPLY PIPING SYSTEM

Test Pressures In Excess Of 1/2 PSIG (3.5 kPa)

1. Disconnect heater with its appliance main gas valve (control valve) and equipment shutoff valve from gas supply piping system. Pressures in excess of 1/2 PSIG will damage heater regulator.
2. Cap off open end of gas pipe where equipment shutoff valve was connected.
3. Pressurize supply piping system by either opening propane supply tank valve for propane gas or opening main gas valve located on or near gas meter for natural gas or using compressed air.
4. Check all joints of gas supply piping system. Apply noncorrosive leak detection fluid to all joints. If bubbles form, there may be a leak.
5. Correct all leaks at once.
6. Reconnect heater and equipment shutoff valve to gas supply. Check reconnected fittings for leaks.

Test Pressures Equal To or Less Than 1/2 PSIG (3.5 kPa)

1. Close equipment shutoff valve (see Figure 20B).
2. Pressurize supply piping system by either opening propane supply tank valve for propane gas or opening main gas valve located on or near gas meter for natural gas or using compressed air.
3. Check all joints from gas meter to equipment shutoff valve for natural gas or propane supply to equipment shutoff valve for propane (see Figures 20A, 20B, and 21). Apply a noncorrosive leak detection fluid to all joints. Bubbles forming show a leak.
4. Correct all leaks at once.

PRESSURE TESTING HEATER GAS CONNECTIONS

1. Open equipment shutoff valve (see Figure 20B).
2. Open main gas valve located on or near gas meter for natural gas or open propane supply tank valve.

CHECKING GAS CONNECTIONS

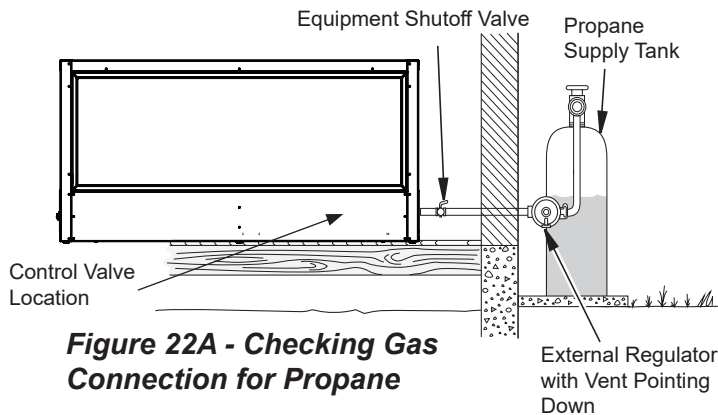

Figure 22A - Checking Gas Connection for Propane

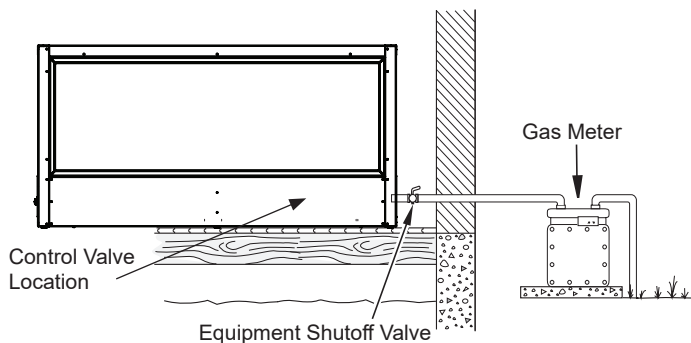

Figure 22B - Checking Gas Connection for Natural Gas

PURGING AIR FROM GAS LINE

Purge air from the supply line as follows:

1. With main shutoff valve open; loosen the screw at the Inlet Pressure Test Point on the Control Valve (Figure 23).
2. Allow flow only until odor of gas is detected.
3. **Once gas flow is detected, immediately tighten inlet screw!**
4. Follow the pipe from the gas supply line connection to the gas valve. Check connections for leaks with soap and water mixture or a noncorrosive leak detection fluid.

⚠ WARNING: If using soap and water, or a noncorrosive leak test solution to test for leaks, DO NOT spray solution onto electronic parts and wiring/connections.

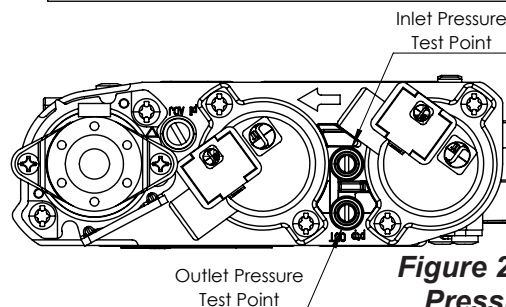

Figure 23 - Control Valve Pressure Test Points

OPERATION

FOR YOUR SAFETY READ BEFORE LIGHTING

⚠ WARNING: If you do not follow these instructions exactly, a fire or explosion may result causing property damage, personal injury or loss of life.

- A. This appliance is equipped with an ignition device which automatically lights the pilot. Do Not try to light the pilot by hand.
- B. **BEFORE LIGHTING** smell all around the appliance area for gas. Be sure to smell next to the floor because some gas is heavier than air and will settle on the floor.

WHAT TO DO IF YOU SMELL GAS

- Do not try to light any appliance.
- Do not touch any electric switch; do not use any phone in your building.
- Immediately call your gas supplier from a neighbor's phone.
- Follow the gas supplier's instructions.
- If you cannot reach your gas supplier, call the fire department.

- C. Main gas valve in this appliance is not serviceable and does not have any control knobs or switches to operate. Do not remove heat shields covering the valve and electronic devices; do not try to repair or modify the valve as it may result in a fire or explosion. Call a qualified service technician if you have any safety concerns.
- D. Do not use this appliance if any part has been under water. Immediately call a qualified service technician to inspect the appliance and to replace any part of the control system and any gas control which has been under water.

⚠ WARNING: Make sure the remote receiver switch is in the OFF position when you are away from home for long periods of time. Heater may come on automatically with the Control Switch in the "REMOTE" position.

OPERATION

LIGHTING INSTRUCTIONS

Initializing the System for the First Time

This fireplace has a gas control with the ability to be set for use in either of two configurations:

CPI (Continuous Pilot Ignition), or **IPI** (Intermittent Pilot Ignition), see chart on page 20.

CPI will leave the ODS Pilot in operation, awaiting the command to ignite the main burner. This command may be input from the remote control handset, or from the **ON/OFF** Control switch located in the fireplace or on an adjacent wall.

IPI will leave the ODS Pilot completely **OFF**, and will initiate the ignition process each time you input the “**ON**” command. The setting may be changed between these two selections at any time by inputting the choice on the remote handset (see Figure 29, page 21).

1. **STOP!** Read the safety information at the bottom of page 18.
2. Lift and remove the Access Panel covering Control Switch inside of the unit (see Product Identification, page 4).
3. Make sure that fresh set of AA batteries are installed into the battery holder in the Control Switch (See Figure 11, page 12) and verify the polarity indicated on the battery holder. If necessary, connect the Control Switch to the Fireplace main wiring harness. Set the Remote Control to the OFF position.

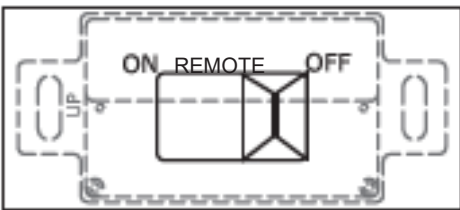

Figure 24A - Control Switch in OFF Position

4. Set the Power Switch (behind Front Screen, Figure 25), and Control Switch to the **OFF** positions (Figure 24A).
5. Make sure equipment shutoff valve is fully open position.
6. Wait five (5) minutes to clear out any gas.
7. Smell around the fireplace, including near the floor. **If you smell gas, STOP! Follow the instructions on the bottom of page 18.**
8. Connect the Power Cord plug to the 110V outlet.
9. Turn ON electric power to the control module at the Power Switch. Do not attempt to light the pilot by hand.

10. Locate Control Switch, either inside the unit (see *Product Identification on page 4*), or mounted in adjacent wall. Move the Control Switch to the REMOTE position (see Figure 24B).
11. Replace access panel over the Control Switch (if mounted in fireplace) and fireplace Screen.

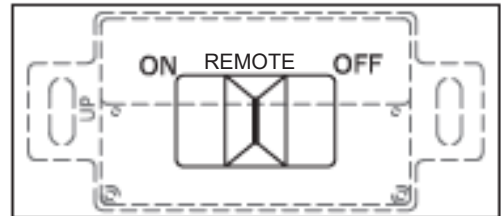

Figure 24B - Control Switch in Remote Position

12. Press the ON/OFF button on the Remote handset. The screen will display all active icons. The receiver will command the Control Module to start the ignition process. Once the pilot flame is lit, the Control Module will open the main valve outlet and the main burner will ignite. A single “beep” from the receiver will confirm the command.

CAUTION: Do not try to adjust heating levels by using the equipment shutoff valve.

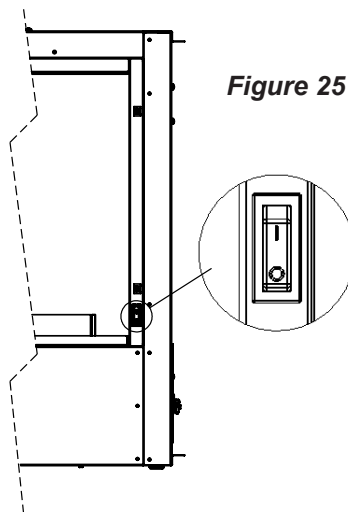

Figure 25 - Power Switch

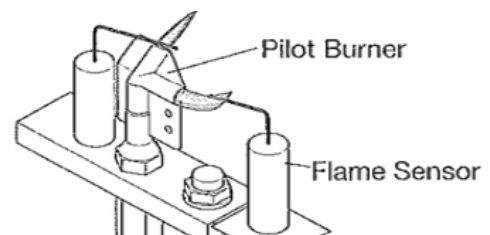

Figure 26 - Pilot Assembly

OPERATION

Manually Turning ON the Appliance (IPI)

Slide the Control Switch to the ON position. This will allow the pilot and then main burner to ignite.

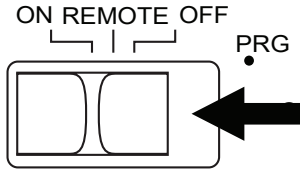

Figure 27 - Control Switch in ON Position

Manually Turning OFF the Appliance (IPI)

Slide the Control Switch to the OFF position. This will turn off the main burner and pilot.

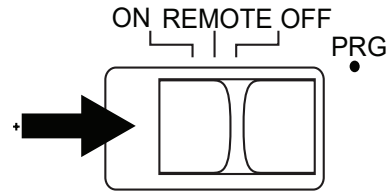

Figure 28 - Control Switch in OFF Position

Setting the Appliance into Continuous Pilot Ignition (CPI) Mode

With the system in the "OFF" position, press the Mode Key (Figure 29) and cycle until the CPI Mode icon is displayed (Figure 29). Pressing the Up Arrow Key will activate the Continuous Pilot Ignition mode (CPI). Pressing the Down Arrow Key will return to IPI. A single "beep" will confirm the command.

Note: If pilot does not stay lit, contact a qualified service person or gas supplier for repairs.

Turning ON the Appliance (CPI)

Slide the Control Switch to the ON position. This will allow the main burner to ignite.

Turning OFF the Appliance (CPI)

Slide the Control Switch to the OFF position. This will turn off the main burner.

Note: If the Continuous Pilot ignition mode is selected, the pilot flame will remain ON. To turn the pilot flame *completely OFF*, return the appliance back to IPI (Intermittent Pilot Ignition) mode using your remote.

Note: You may be running this heater for the first time after hooking up to gas supply. If so, the Control Switch may need to be operated two or more times; this will allow air to bleed from the gas system.

Command Definitions

Pilot IPI/CPI Switch	Operation Switch	Command Name	Fireplace State
Set to IPI	OFF	Turn OFF	Flames OFF
Set to IPI	ON	Turn ON	Pilot & Main Burner Flames ON
Set to CPI	OFF	Pilot ON	Pilot Flame ON
Set to CPI	ON	Turn ON	Pilot & Main Burner Flames ON

TO TURN OFF GAS TO APPLIANCE

Shutting Off Heater

1. Turn off the Appliance.
2. Turn off all electric power to the appliance; if service is to be performed, unplug power cord from the power outlet.

Shutting Off Gas Supply

1. Turn the equipment shutoff valve to the full OFF position.
2. If necessary, replace media tray or access panel.

OPERATION

REMOTE CONTROL OPERATION

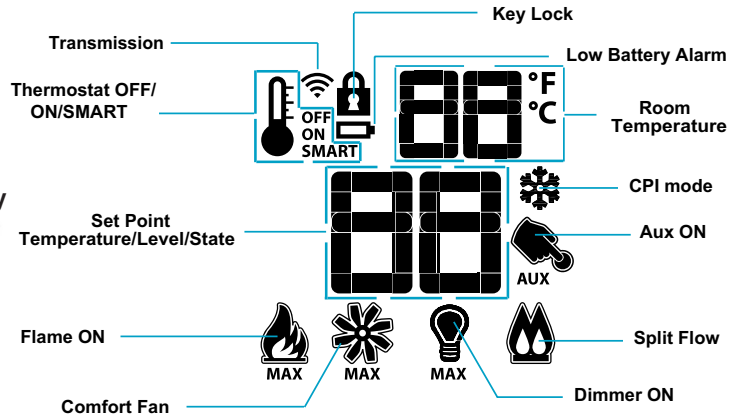
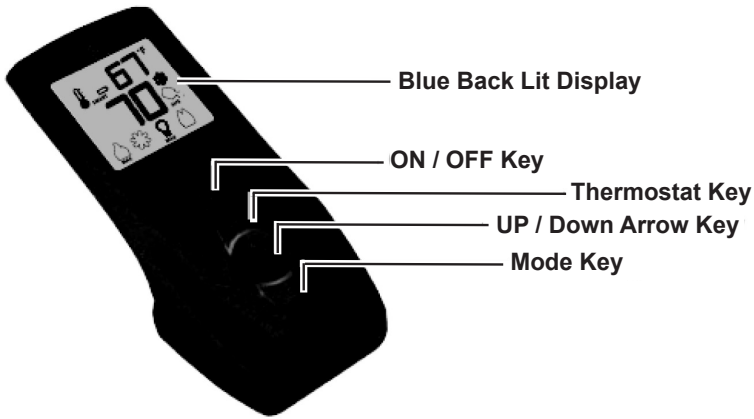

Figure 29 - Remote Handset Keys and Display

Temperature Setting (Degrees in “C”/“F”)

1. With the system in the “OFF” position, press the “THERMOSTAT” and the “MODE” key at the same time.
2. On the screen, verify that a °C or °F is visible to the right of the room temperature display (see Figure 30).

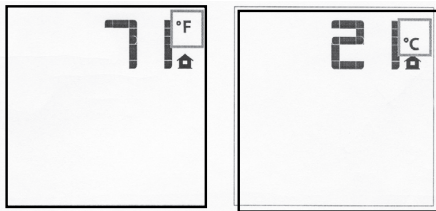
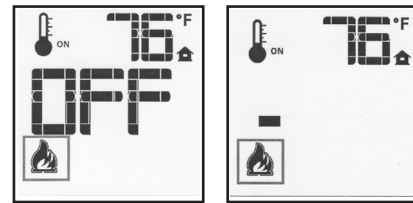
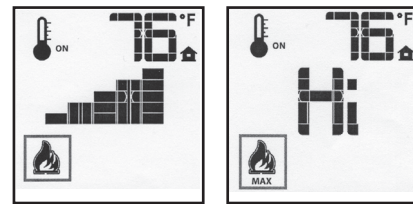

Figure 30 - Remote Control Display in degrees Fahrenheit and degrees Celsius



Flame OFF Flame Level 1



Flame Level 5 Flame Level Max.

Figure 31 - Flame Levels Display

Turning ON the Appliance

Press the ON/OFF button on the transmitter. The transmitter’s display will show only the room temperature and icon (see Figure 30). The receiver will command the Control Board to start the ignition process. A single “beep” will be heard confirming the command was received. Once the pilot flame has been ignited, the control valve will open, and the main burner will ignite.

Turning OFF the Appliance

Press the ON/OFF button on the transmitter. The transmitter’s display will show only the room temperature and icon (see Figure 30). The receiver will command the Control Board to turn OFF the main burner. A single “beep” will be heard confirming the command was received. Depending on the selected mode (IPI or CPI), the pilot will either shut off or remain active.

If set to IPI, the pilot will be shut off. If CPI is selected, the pilot will remain active.

Flame Height Control

With the system on, and the main burner flame operating at the maximum level, press the down arrow key one time to reduce the flame height by one step (see Figure 31). Continue to press the down arrow to reduce the flame height one step at a time. Below the "HI" setting, there are five levels or steps of flame, which will show on the LCD screen as "stairs". When adjusted past the single step it is in “OFF” position.

Press the up arrow key one time to increase the flame height.

If the up arrow key is pressed when the flame is OFF, a single “beep” will be heard confirming the command was received; the flame will come on at the highest position.

OPERATION

REMOTE CONTROL OPERATION

Room Thermostat

The remote control can operate as a room thermostat. The thermostat can be set to a desired temperature to control the comfort level in the room.

1. To activate this function, press the **THERMOSTAT** key. The display on the handset will change to show that the room thermostat is ON and the set temperature is now displayed (see Figure 32).
2. Adjust the set temperature (shown on display) by pressing the up or down arrow keys until the desired set temperature is displayed (see Figure 32).

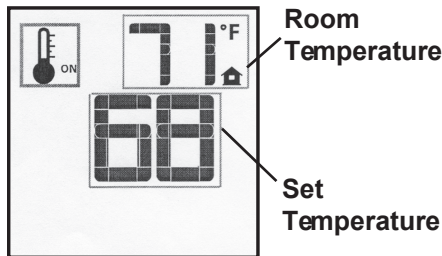

Figure 32 - Remote Control Displaying Room Temperature and Set Temperature

Smart Thermostat

The Smart Thermostat function adjusts the flame height in accordance to the difference between the set point temperature and the actual room temperature. As the room temperature gets closer to the set point, the Smart Function will modulate the flame to a lower setting.

1. To activate this function, press the **Thermostat** key until the word "Smart" appears to the right of the temperature bulb on the screen (see Figure 33).
2. To adjust the temperature setting, press the up or down arrow keys until the desired temperature is shown in the display screen.

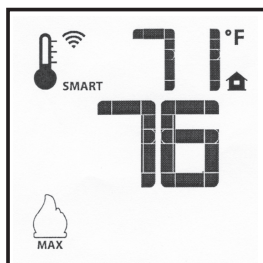

Figure 33 - Remote Control Displaying Room Temperature and Set Temperature

Key Lock

This function will lock the keys to avoid any unsupervised operation.

1. To activate this function, press the **MODE** key and the UP arrow at the same time. The display on the handset will change to show a "lock" icon (See Figure 34).
2. To deactivate this function, again press the **MODE** key and the UP arrow at the same time. The display on the handset will show the "lock" icon has disappeared.

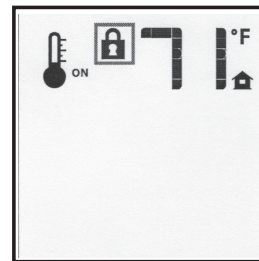

Figure 34 - Remote Control Displaying Room Temperature and "Lock" Icon

Low Battery Power Indication Receiver

The life span of the receiver batteries depends on various factors: battery quality, number of appliance operations, number of thermostat set point changes, etc.

When the receiver batteries are low, no "beep" will sound from the receiver when a transmitter command is sent. Replace batteries when this happens.

Transmitter

The life span of the transmitter batteries depends upon various factors: battery quality, number of appliance operations, number of thermostat set point changes, etc.

When the transmitter batteries are low, a "battery" icon will appear on the display (see Figure 35). Replace the batteries when this icon appears.

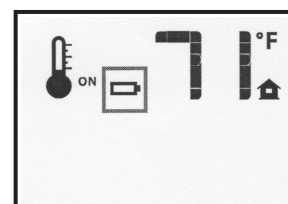

Figure 35 - Remote Control Displaying the "Low Battery" Icon

INSPECTING BURNERS

IMPORTANT: Owners should check pilot flame pattern and burner flame pattern often. Incorrect flame patterns indicate the need for cleaning (see Care and Maintenance, page 24) or have serviced.

⚠ WARNING: Only a qualified service person should service and repair heater. This includes maintenance requiring replacement or alteration of components.

PILOT FLAME PATTERN

Figure 36 shows a correct pilot flame pattern. Figure 37 shows an incorrect pilot flame pattern. The incorrect pilot flame is not touching the Pilot Flame Sensor. This will cause the circuit to open, which shuts the heater off.

If pilot flame pattern is incorrect, as shown in Figure 37:

- turn heater off (see Manually Turning Off the Appliance, page 20)
- see ODS/Pilot page 25.

BURNER FLAME PATTERN

Figure 38, page 24 shows a correct burner flame pattern. Figure 39, page 24 shows an incorrect burner flame pattern. If burner flame pattern is incorrect then:

- turn heater off (see Manually Turning Off the Appliance, page 20).
- see Troubleshooting page 30.

⚠ WARNING: If incorrect flame occurs, your heater could produce increased levels of carbon monoxide. If the burner flame pattern seems excessive (See Figure 39, page 24) follow instructions under Care and Maintenance, Main Burner on page 24.

BURNER PRIMARY AIR OPENINGS

Air is drawn into the burner through the openings in the assembly at the entrance to the burner. These openings may become blocked with dust or lint. Periodically inspect these openings for any blockage and clean as necessary. Blocked air openings will create soot. If you suspect the burner openings are blocked, follow the instructions under Care and Maintenance, Main Burner on page 24.

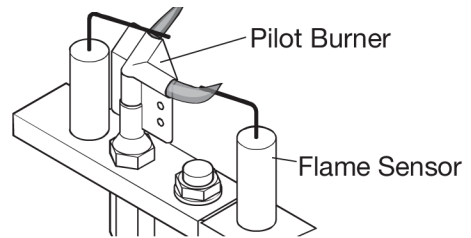

Figure 36 - Correct Pilot Flame Pattern

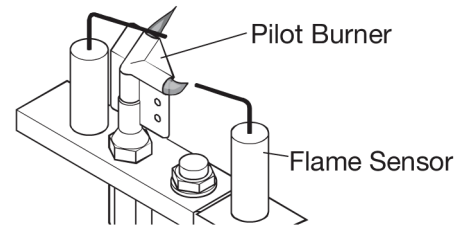

Figure 37 - Incorrect Pilot Flame Pattern

CARE AND MAINTENANCE

⚠ WARNING: Turn off heater and let cool before servicing.

⚠ CAUTION: You must keep control areas, burner, and circulating air passageways of heater clean. Inspect these areas of heater before each use. Have heater inspected yearly by a qualified service technician. Heater may need more frequent cleaning due to excessive lint from carpeting, bedding material, pet hair, etc.

⚠ WARNING: Failure to keep the primary air opening(s) of the burner(s) clean may result in sooting and property damage.

MAIN BURNER

Periodically inspect all burner flame holes with the heater running. Figure 38 shows a correct burner flame pattern. Figure 39 shows an incorrect burner flame pattern. If burner flame pattern is incorrect, the burner should be inspected and cleaned. All flame holes should be open with yellow flame present. All round burner flame holes should be open with a small blue flame present. Some burner flame holes may become blocked by debris or rust, with no flame present. If so, turn off the heater and let it cool, and remove blockage or replace burner. Blocked burner flame holes will create soot.

We recommend that you clean the unit every 2,500 hours of operation or every three months. We also recommend that you keep the burner tube and pilot assembly clean and free of dust and dirt. To clean these parts we recommend using compressed air no greater than 30psi. Your local computer store, hardware store, or home center may carry compressed air in a can.

You can use a vacuum cleaner in the blow position. If using compressed air in a can, please follow the directions on the can. If you don't follow directions on the can, you could damage the pilot assembly.

1. Shut off the unit, including the pilot. Allow the unit to cool for at least thirty minutes.
2. Inspect burner, pilot and primary air inlet holes on injector for dust and dirt (see Figure 40, page 25).
3. Blow air through the ports/slots and holes in the burner. Also clean the pilot assembly.
4. Check the injector holder located at the end of the burner tube again. Remove any large particles of dust, dirt, lint, or pet hair with a soft cloth or vacuum cleaner nozzle.
5. Blow air into the primary air holes on the injector holder.
6. In case any large clumps of dust have now been pushed into the burner. Repeat steps 3 and 4.

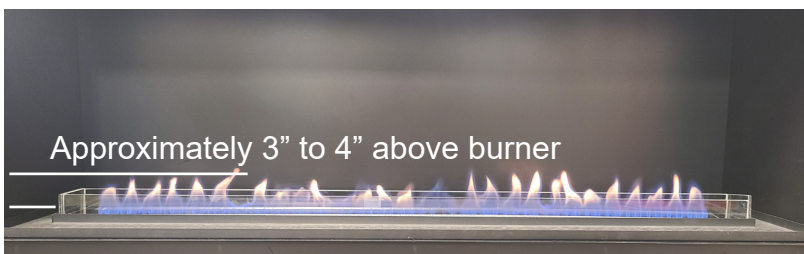

Figure 38 - Correct Burner Flame

⚠ WARNING: Do not loosen the screw fixing the setting of the air shutter. Do not change the setting of the air shutter. To do so may cause poor combustion and sooting.

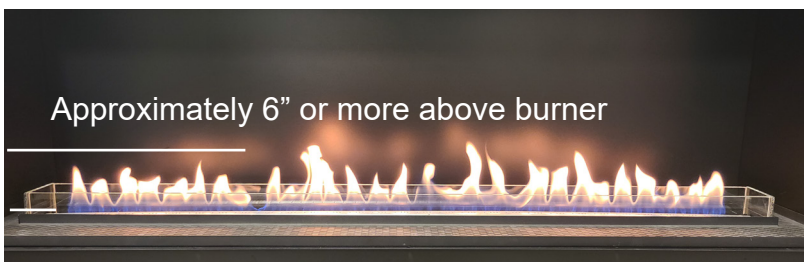

Figure 39 - Incorrect Burner Flame

⚠ WARNING: If excessive flame size occurs, your heater could produce increased levels of carbon monoxide. If the burner flame pattern seems excessive, follow instructions above.

CARE AND MAINTENANCE

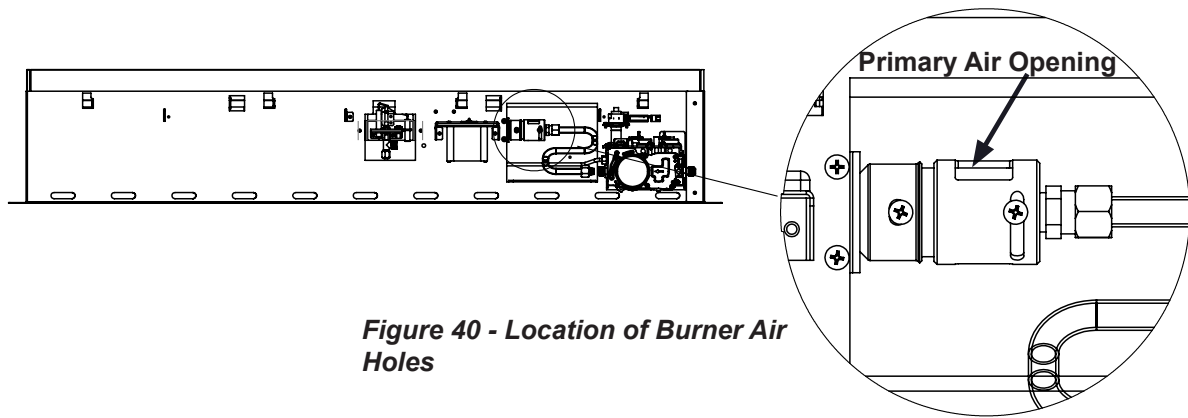

Figure 40 - Location of Burner Air Holes

ODS/PILOT

⚠ CAUTION: Never use a wire, needle, or similar object to clean ODS/pilot. This can damage ODS/pilot unit.

Use a vacuum cleaner, pressurized air, or a small, soft bristled brush to clean.

A yellow tip on the pilot flame indicates dust and dirt in the pilot assembly. There is a small pilot air inlet hole just below the mounting flange of the pilot assembly (see Figure 41). With the unit off, lightly blow air through the air inlet hole. You may blow through a drinking straw if compressed air is not available. Soot or debris may accumulate along the surface of the Pilot Flame Sensor. This sensor may be cleaned with a soft brush or fine sandpaper. Care should be taken to avoid bending the wire while cleaning.

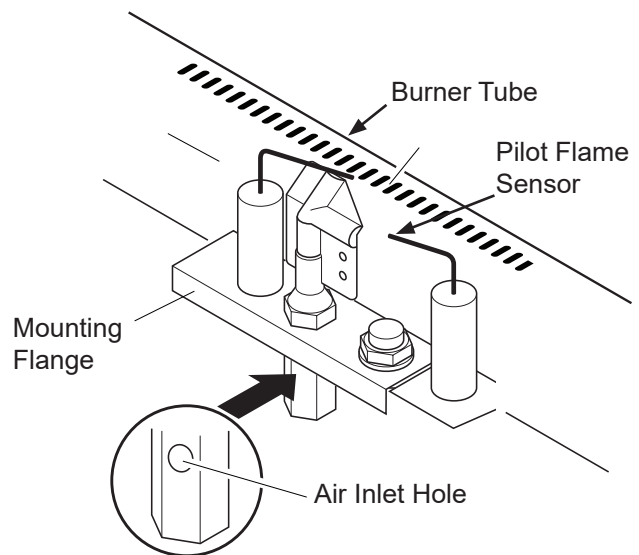

Figure 41 - ODS Pilot Air Holes

OPTIONAL ACCESSORY INSTALLATION

L2S48-1 - TWO-SIDE FIREPLACE CONVERSION KIT

Complete the Rough Opening Framing using the dimensions shown in Figure A1.

1. After removing the screws and the *Rear Insulation Panel*, also remove the screws and the *Rear Firebox Panel*. Install the 3 *Fireplace Framing (Stand-Off) Brackets* onto the top of the Fireplace Assembly. Install the 4 (flat) *Side Firebox Framing Brackets* onto the sides of the Fireplace. Install the Fireplace Assembly, including the 3 previously assembled *Top Framing Brackets* and the 4 *Side Framing Brackets* (leave them unbent/flat at this time) into the opening until the Fireplace Assembly is flush with the wall.

2. At this point install the second set of 3 *Top Framing Brackets* (included in L2S48-1 Kit) as shown in Figure A2.

3. Finally bend the 4 *Side Framing Brackets* around the framing to match the brackets on the opposite side of the framed wall.

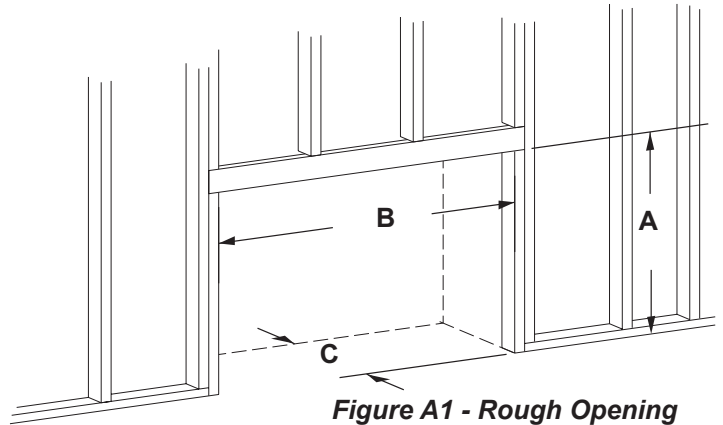

Figure A1 - Rough Opening using L2S48-1 Kit

Rough Opening Dimensions Using L2S48-1 Kit

MODEL	A	B	C
BVFIL48NRT	31.3/8"	54.1/2"	11.6875"*
BVFIL48LRT	31 3/8"	54.1/2"	11.6875"*

* Subtract 0.5" from this dimension for each "Flush Face" side when installing Fireplace Assembly in a "Flush Face" finished condition.

Included in the kit:



Side Framing Brackets - 4pc.



Top Framing Brackets - 3pc.

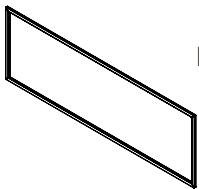

Mesh Screen - 1pc.

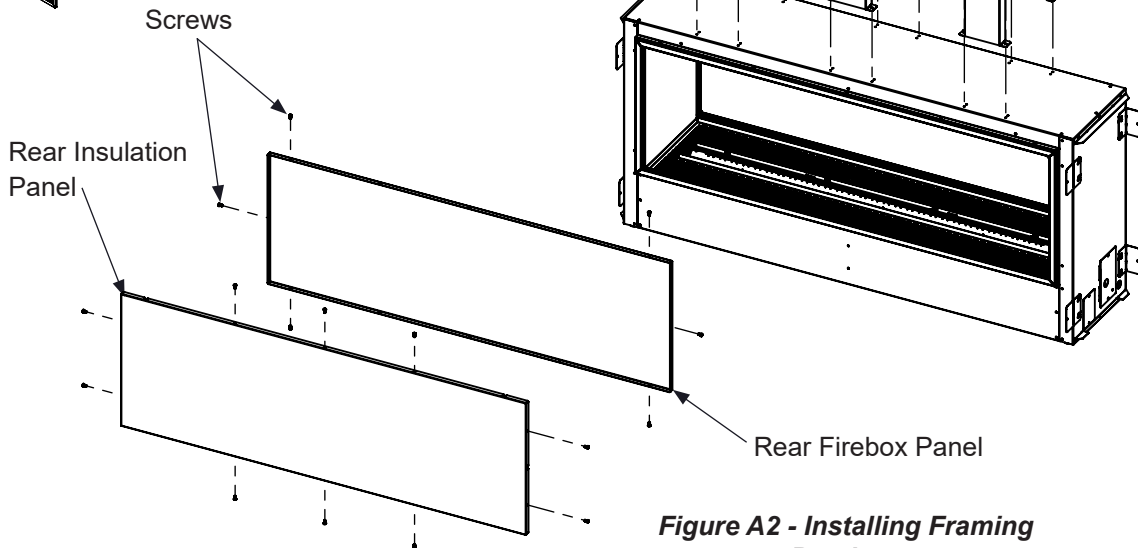
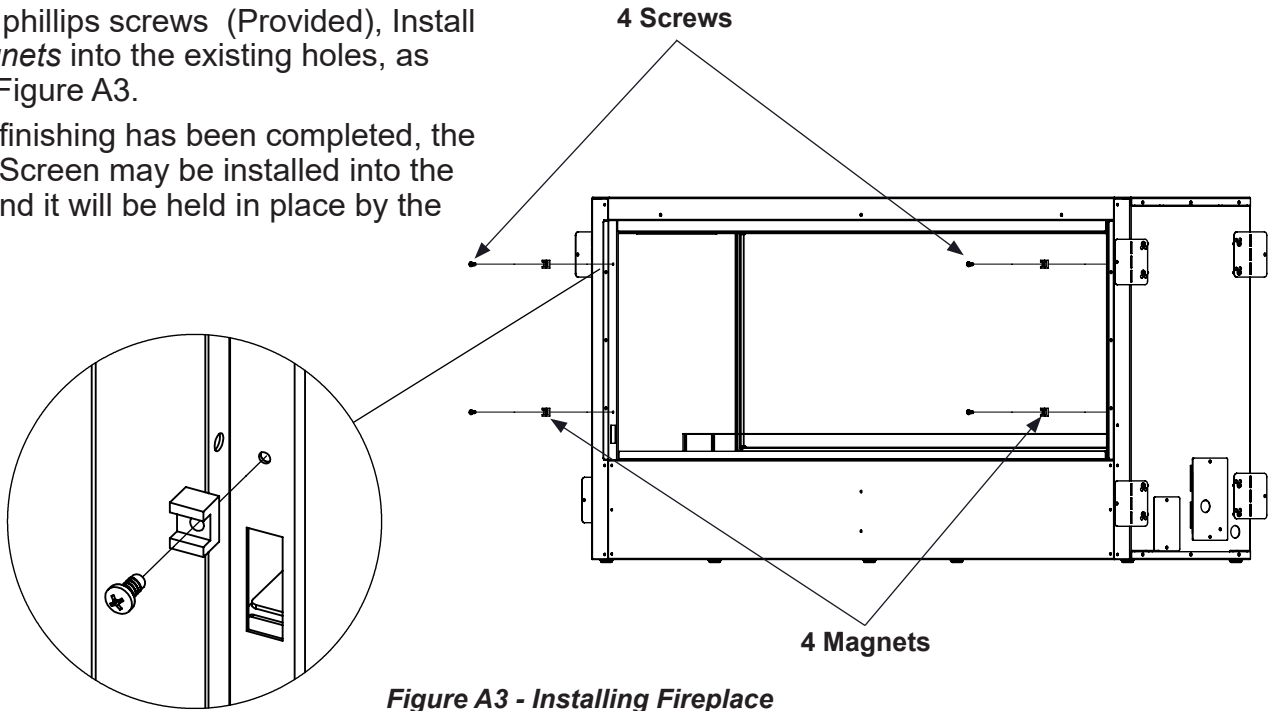

Figure A2 - Installing Framing Brackets

OPTIONAL ACCESSORY INSTALLATION

Using the phillips screws (Provided), Install the 4 *Magnets* into the existing holes, as shown in Figure A3.

After wall finishing has been completed, the Fireplace Screen may be installed into the opening and it will be held in place by the magnets.



LLS48-1 DECORATIVE LOG SET

Logs may be arranged in any desired position to create your preferred appearance. However, do not place logs in a way that interferes with the flame, rests against or over the burner, or makes contact with the glass wind barriers.

IMPORTANT: Logs must not impinge upon burner flame.

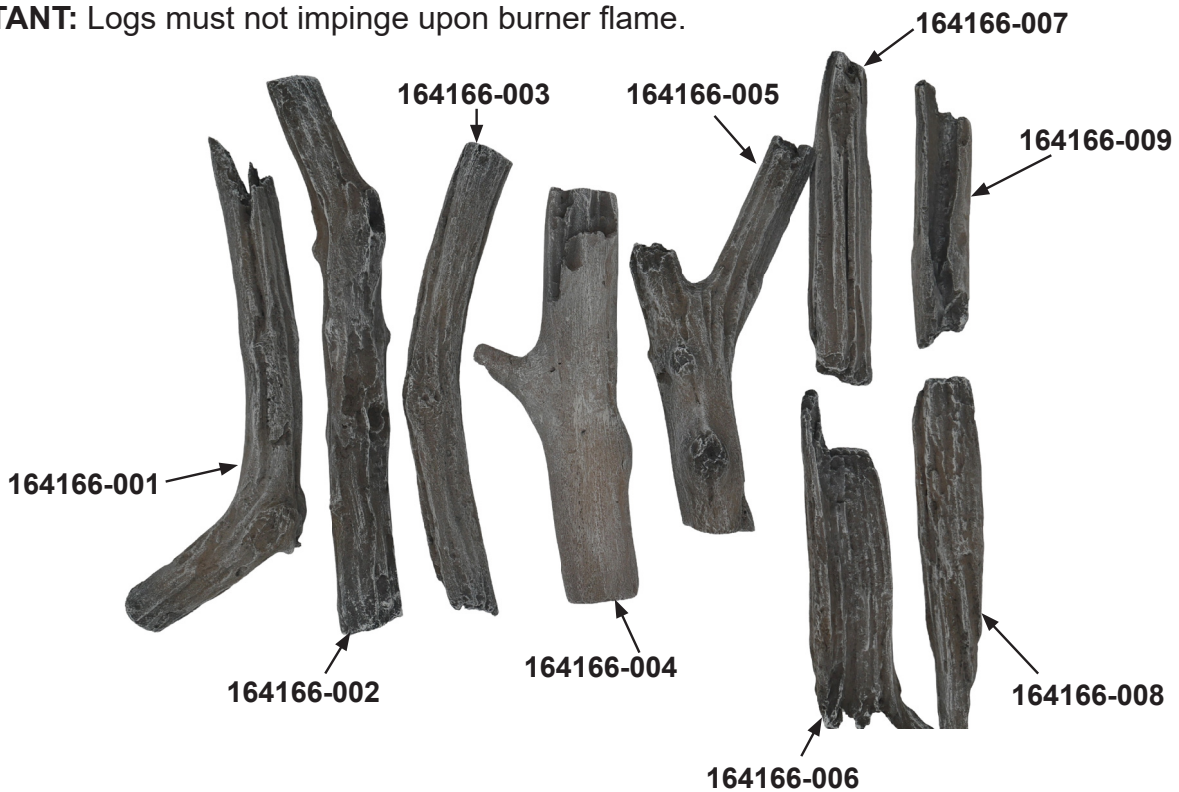

WIRING DIAGRAM

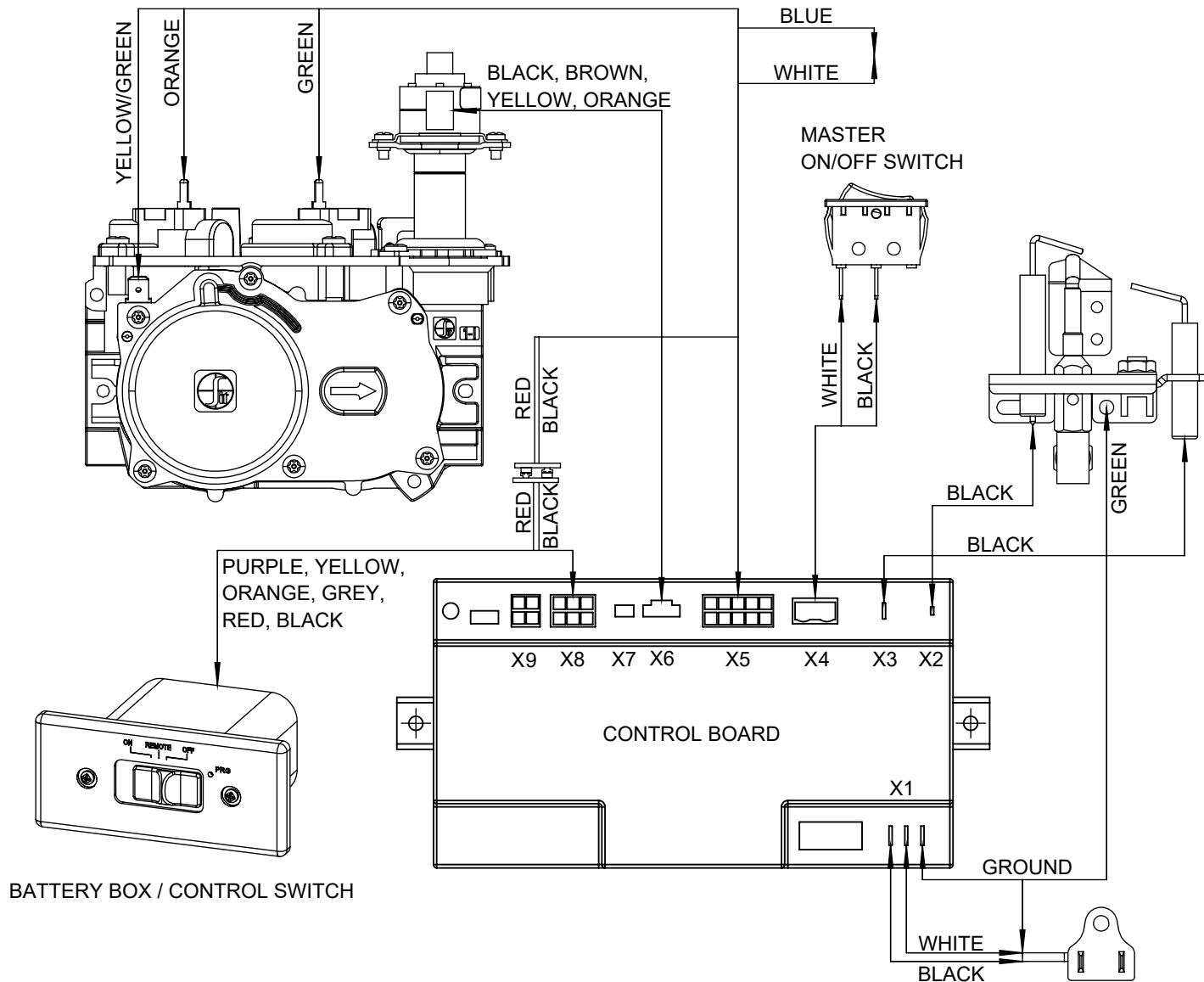

TROUBLESHOOTING

⚠ WARNING: If you smell gas:

- Shut off gas supply.
- Do not try to light any appliance.
- Do not touch any electrical switch; do not use any phone in your building.
- Immediately call your gas supplier from a neighbor's phone. Follow the gas supplier's instructions.
- If you cannot reach your gas supplier, call the fire department.

⚠ WARNING: Only a qualified service technician should service and repair heater. Make sure that power is turned off before proceeding. Turn off and let cool before servicing.

IMPORTANT: Operating heater where impurities in air exist may create odors. Cleaning supplies, paint, paint remover, cigarette smoke, cements and glues, new carpet or textiles, etc., create fumes. These fumes may mix with combustion air and create odors.

Note: All troubleshooting items are listed in order of operation.

TROUBLESHOOTING

Problem	Possible Cause	Corrective Action
Gas odor in or around fireplace prior to igniting.	Gas leak. See Warning Statement at the bottom of page 28.	Locate and correct all leaks (see <u><i>Checking Gas Connections, page 17</i></u>).
Control Switch in "ON" position but there is no spark at ODS/pilot.	<ol style="list-style-type: none"> 1. Control Valve is in "Lockout" 2. No a/c power/Low battery 3. Ignitor electrode is not connected to ignitor cable. 4. Ignitor cable is pinched or wet. 5. Ignitor electrode is positioned wrong, dirty, or ignitor electrode is broken. 6. Broken ignitor cable. 7. Poor or nonexistent ground. 8. Bad Electronic Board. 	<ol style="list-style-type: none"> 1. Turn Control Switch to OFF, Wait a few seconds and then back to ON. 2. Verify power source. 3. Reconnect cable. 4. Free ignitor cable if pinched by any metal or tubing. Keep ignitor cable dry. 5. Clean, align, or replace electrode. 6. Replace ignitor cable. 7. Make sure ground cable is tightly connected. 8. Replace Electronic Board.
Control Switch in "ON" position, there is a spark at ODS/pilot but no pilot flame present.	<ol style="list-style-type: none"> 1. Gas supply is turned off or equipment shutoff valve is closed. 2. No A/C Power / Low battery 4. Air in gas lines (new installation or recent gas interruption). 5. ODS / pilot is clogged. 6. Depleted gas supply (propane). 7. Incorrect inlet gas pressure or inlet regulator is damaged. 	<ol style="list-style-type: none"> 1. Turn on gas supply or open equipment shutoff valve. 2. Verify power source. 4. Repeat igniting operation until air is removed. 5. Clean ODS/pilot (see <u><i>Care and Maintenance, page 25</i></u>) or replace ODS/pilot assembly. 6. Contact local propane gas company. 7. Check inlet gas pressure or replace gas control.
Burner ignition is delayed	<ol style="list-style-type: none"> 1. Equipment shutoff valve is not fully open. 2. Main Burner carryover ports clogged with dirt/debris. A) Low gas pressure. B) Dirty or partially clogged ODS/pilot. 7. Control valve damaged. 	<ol style="list-style-type: none"> 1. Fully open equipment shutoff valve. 2. Clean Main Burner - see <u><i>Inspecting Burners page 23</i></u> and <u><i>Care and Maintenance page 24</i></u>. 5. A) Contact local natural or propane gas company. B) Clean ODS/pilot (see <u><i>Care and Maintenance, page 25</i></u>) or replace ODS/pilot assembly. 7. Replace gas control.

TROUBLESHOOTING

Problem	Possible Cause	Corrective Action
Burner lights and goes out; ODS pilot stays on.	<ol style="list-style-type: none"> 1. Loose wire connections. 2. Clogged or dirty burner ignition or carryover ports. 3. Blocked or obstructed burner orifice. 4. Low gas pressure. 5. Faulty ODS pilot. 6. Faulty control valve. 	<ol style="list-style-type: none"> 1. Check/repair connections at valve and control module. 2. Clean burner ports see <i>Cleaning and Maintenance</i> page 24. 3. Clean burner orifice see <i>Cleaning and Maintenance</i> page 24. 4. Contact your local natural or propane gas company. 5. Replace ODS pilot. . 6. Replace control valve.
ODS pilot and Burner will light; then both go out.	<ol style="list-style-type: none"> 1. Low gas pressure. 2. Flame sensor dirty. 3. Loose wiring connections. 4. Clogged or obstructed burner ports or orifice. 5. Not enough fresh air/ODS operates. 6. Faulty ODS Pilot. 7. Faulty Control Valve 	<ol style="list-style-type: none"> 1. Contact your local natural or propane gas company. 2. Clean Pilot Flame Sensor see <i>Care and Maintenance</i> page 25. 3. Check all connections - control module and valve. 4. Check/clean Burner ports and Main Burner Orifice. See <i>Care and Maintenance</i> page 24. 5. Ventilate room; open door or window. 6. Clean or replace ODS Pilot. 7. Replace control valve.
Incorrect appearing burner flame.	<ol style="list-style-type: none"> 1. Low gas pressure. 2. Clogged or obstructed burner ports or orifice. 3. Faulty Control Valve 	<ol style="list-style-type: none"> 1. Contact your local natural or propane gas company. 2. Check/clean Burner ports and Main Burner Orifice. See <i>Care and Maintenance</i> page 24. 3. Replace control valve.
Main Burner “backfires”. Ignites inside of burner.	<ol style="list-style-type: none"> 1. Clogged or obstructed burner ports or orifice. 2. Low gas pressure. 	<ol style="list-style-type: none"> 1. Check/clean Burner ports and Main Burner Orifice. See <i>Care and Maintenance</i> page 24. 2. Contact your local natural or propane gas company.
Fireplace produces unwanted odors.	<ol style="list-style-type: none"> 1. Initial burn-off and curing of paints and manufacturing oils and chemicals. 2. Vapors from paint, new carpet, air fresheners or hairspray are present. 	<ol style="list-style-type: none"> 1. This will not last long; ventilate room. 2. Ventilate room; open door or window until odor stops.

TROUBLESHOOTING

Problem	Possible Cause	Corrective Action
Whistle noise from fireplace.	<ol style="list-style-type: none"> 1. Check gas pressure. 2. Air is present in gas line. 3. Corrugated gas line is crimped or a smaller diameter than required. 	<ol style="list-style-type: none"> 1. Contact your local natural or propane gas company. 2. Bleed the air from gas line. See Checking Gas connection, Page 17. 3. Straighten or replace corrugated gas line.

REPLACEMENT PARTS

Note: Use only original replacement parts. This will protect your warranty coverage for parts replaced under warranty.

PARTS UNDER WARRANTY

Contact authorized dealers of this product. If they can't supply original replacement parts, call Customer Care toll free at 1-866-762-4050 for referral information.

When calling Customer Care or your dealer, have ready:

- Your name

- Your address
- Model and serial number of your heater
- How heater was malfunctioning
- Type of gas used (Propane or Natural gas)
- Purchase date

Usually, we will ask you to return the defective part to the factory.

PARTS NOT UNDER WARRANTY

Contact authorized dealers of this product. If they can't supply original replacement part(s) call Customer Care toll free at 1-866-762-4050 for referral information.

When calling Customer Care have ready:

- Model number of your heater
- The replacement part number

PARTS

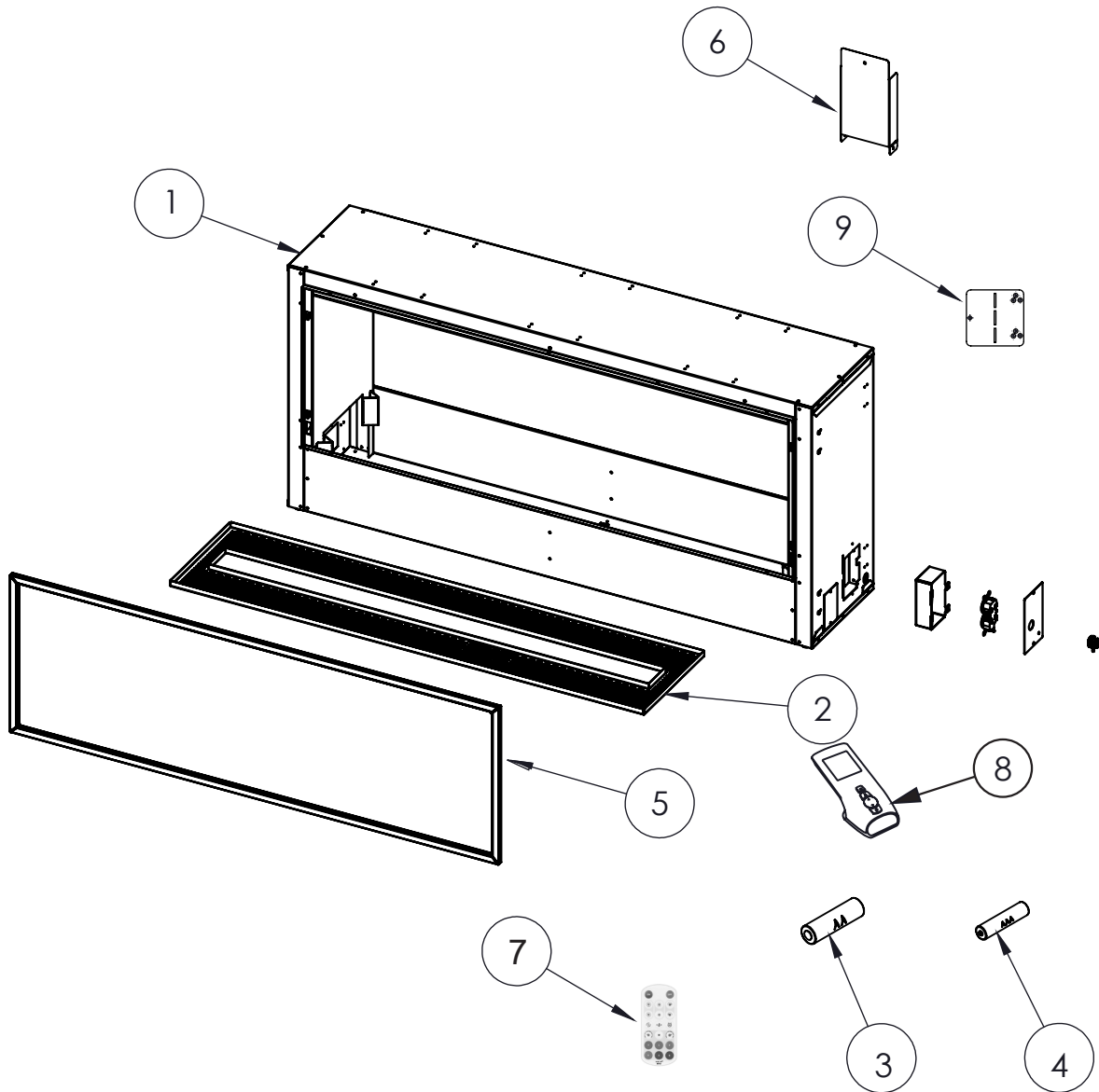

ITEM	PART #	DESCRIPTION	QTY
1	N/A	Assembly, Fireplace	1
2	164110-48HT	Burner Media Tray	1
3	161333-01	Battery, AA	4
4	161332-01	Battery, AAA	3
5	164127-48	Mesh Screen	1
6	164137-01	Mounting Bracket, Top	3
7	164162-01	Controller W/Remote, LED Lighting	1
8	164155-01	Handset, Burner System	1
9	164138-01	Mounting Bracket, Side	4
PART AVAILABLE - NOT SHOWN			
		Hardware Package	1

PARTS

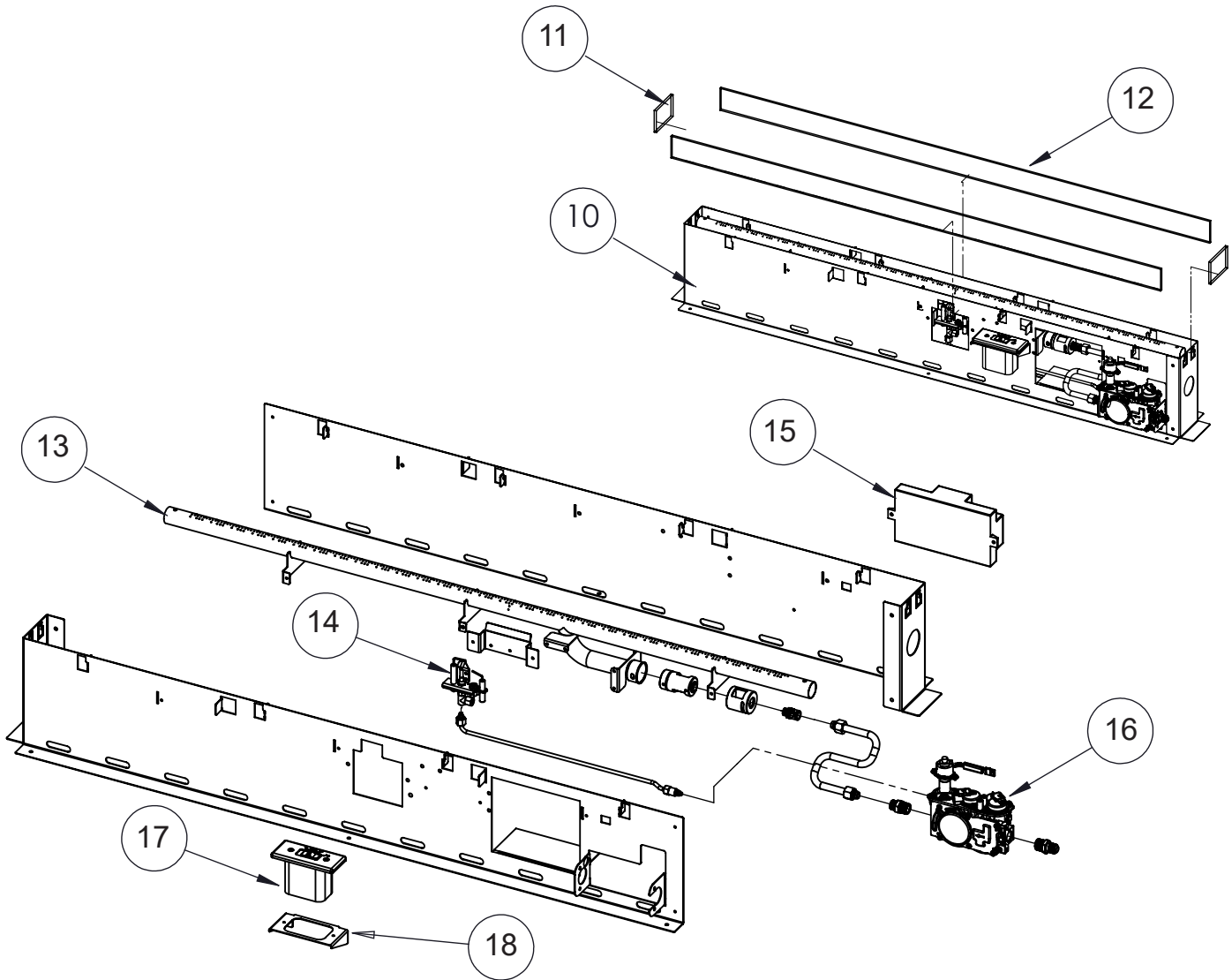

ITEM	PART #	DESCRIPTION	QTY
10	161460-01	Gas Train Assembly - NG	1
10	161460-02	Gas Train Assembly - Propane	1
11	164133-01	Glass, Burner Barrier - Side	2
12	164133-02	Glass, Burner Barrier - Front/Rear	2
13	164100-01	Burner, Main	1
14	164151-01	ODS Pilot - NG	1
14	164151-02	ODS Pilot - Propane	1
15	164153-01	Board, Control	1
16	164150-01	Valve, Control - NG	1
16	164150-02	Valve, Control - Propane	1
17	164156-01	Control Switch, Battery Box	1
18	164167-01	Cover, Control Switch	1
PART AVAILABLE - NOT SHOWN			
	164154-01	Wiring Harness	1

SERVICE HINTS

When Gas Pressure Is Too Low

- pilot will not stay lit
 - burners will have delayed ignition
 - fireplace will not produce specified heat
 - propane gas supply might be low (propane units only)
- You may feel your gas pressure is too low. If so, contact your local gas supplier.

TECHNICAL SERVICE

You may have further questions about installation, operation, or troubleshooting. If so, contact Customer Care at 1-866-762-4050.

ACCESSORIES

Purchase these heating accessories, please visit our website www.bluegrassliving.com or give us a call at 1-866-762-4050.

LLS48-1 DECORATIVE LOG SET

“Driftwood” Styled Log Set - Add a touch of natural warmth to your fireplace. (Logs shown with optional Ceramic Fiber Rocks CFR-G).



L2S48-1 - TWO-SIDE FIREPLACE CONVERSION KIT

Allows viewing from both sides of an interior wall.

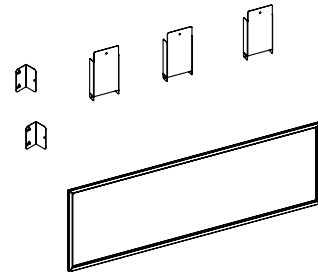

EQUIPMENT SHUTOFF VALVE

For all models. Equipment shutoff valve with 1/2" NPT threads.

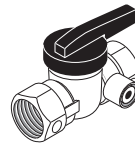

210042 PREMIUM REFLECTIVE CLEAR FIRE GLASS - 10 LB. BAG



210040 PREMIUM REFLECTIVE BLACK FIRE GLASS - 10 LB. BAG



WARRANTY
KEEP THIS WARRANTY

Model _____

Serial No. _____

Date Purchased _____

Keep receipt for warranty verification.

REGISTER YOUR PRODUCT AT WWW.BLUEGRASSLIVING.COM
BLUEGRASS LIVING, INC. LIMITED WARRANTIES

New Products

Standard Warranty: Bluegrass Living, Inc. warrants this new product and any parts thereof to be free from defects in material and workmanship for a period of one (1) year from the date of first purchase from an authorized dealer provided the product has been installed, maintained and operated in accordance with Bluegrass Living, Inc.'s warnings and instructions.

For products purchased for commercial, industrial or rental usage, this warranty is limited to 90 days from the date of first purchase.

Terms Common to All Warranties

The following terms apply to all of the above warranties:

Always specify model number and serial number when contacting the manufacturer. To make a claim under this warranty, the bill of sale or other proof of purchase must be presented.

This warranty is extended only to the original retail purchaser when purchased from an authorized dealer, and only when installed by a qualified installer in accordance with all local codes and instructions furnished with this product.

This warranty covers the cost of part(s) required to restore this product to proper operating condition and an allowance for labor when provided by a Bluegrass Living, Inc. Authorized Service Center or a provider approved by Bluegrass Living, Inc.. Warranty parts must be obtained through authorized dealers of this product and/or Bluegrass Living, Inc. who will provide original factory replacement parts. Failure to use original factory replacement parts will void this warranty.

Traveling, handling, transportation, diagnostic, material, labor and incidental costs associated with warranty repairs, unless expressly covered by this warranty, are not reimbursable under this warranty and are the responsibility of the owner.

Excluded from this warranty are products or parts that fail or become damaged due to misuse, accidents, improper installation, lack of proper maintenance, tampering or alteration(s).

This is Bluegrass Living, Inc.'s exclusive warranty, and to the full extent allowed by law; this express warranty excludes any and all other warranties, express or implied, written or verbal and limits the duration of any and all implied warranties, including warranties of merchantability and fitness for a particular purpose to one (1) year on new products and 30 days on factory reconditioned products from the date of first purchase.

Bluegrass Living, Inc. makes no other warranties regarding this product.

Bluegrass Living, Inc.'s liability is limited to the purchase price of the product and Bluegrass Living, Inc. shall not be liable for any other damages whatsoever under any circumstances including direct, indirect, incidental, or consequential damages.

Some states do not allow limitations on how long an implied warranty lasts or the exclusion or limitation of incidental or consequential damages, so the above limitation or exclusion may not apply to you.

This warranty gives you specific legal rights, and you may also have other rights which vary from state to state.



Bluegrass Living, Inc.
2701 Industrial Drive
Bowling Green, KY 42101
1-866-762-4050

200608-01
Rev. A
06/25