

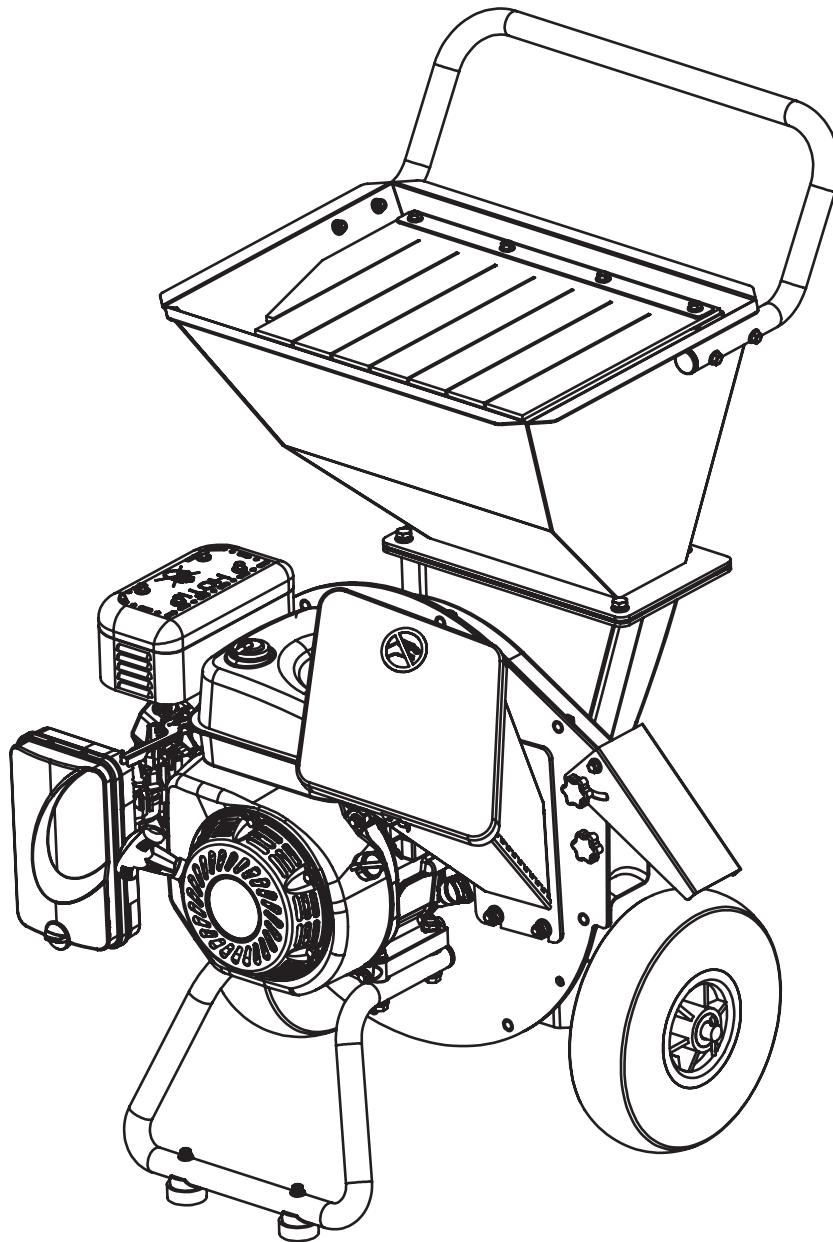

Model: PTG36212

# 3 IN 1 WOOD CHIPPER/SHREDDER OPERATOR'S MANUAL



**WARNING:**

Read carefully and understand all INSTRUCTIONS before operating. Failure to follow the safety rules and other basic safety precautions may result in serious personal injury.

Save these instructions in a safe place and on hand so that they can be read when required. Keep these instructions to assist in future servicing.

[support@pulsar-products.com](mailto:support@pulsar-products.com)

# WARNING SYMBOL



**WARNING:** This is the warning symbol to get your high attention for the instruction notice, which should be followed to avoid the potential serious personal injury. Anyone to use this equipment should read all the instructions of this manual. Keep this instruction manual for future reference.

Do not allow children to operate this chipper shredder. Keep small children away from the area while chipper shredder is in use. Do not allow adults to operate the chipper shredder without proper instruction.

## WARNING SYMBOLS AND DEFINITIONS

	<b>DANGER</b>	DANGER INDICATES A SERIOUS INJURY OR FATALITY WILL RESULT IF THE SAFETY INSTRUCTIONS THAT FOLLOW THIS SIGNAL WORD ARE NOT OBEYED.
	<b>WARNING</b>	WARNING INDICATES A HAZARD WHICH, IF NOT AVOIDED, COULD RESULT IN DEATH OR SERIOUS INJURY AND/OR PROPERTY DAMAGE.
	<b>CAUTION</b>	CAUTION INDICATES YOU CAN OR YOUR EQUIPMENT CAN BE HURT IF THE SAFETY INSTRUCTIONS THAT FOLLOW THIS SIGNAL WORD ARE NOT OBEYED.
	<b>IMPORTANT</b>	IMPORTANT INDICATES HELPFUL INFORMATION FOR PROPER ASSEMBLY, OPERATION, OR MAINTENANCE OF YOUR EQUIPMENT.

### Intended Use

#### Foreseeable Misuse

This is a petrol engine-powered chipper shredder that breaks up leaves and wooded pieces such as tree branches, brush, and limbs into smaller volume via a high-speed rotor containing chipping blades and shredding hammers. It shall not be used for any other purpose.



### WARNING

1. You must read, understand and comply with all safety and operating instructions in this manual before attempting to setup and operate your chipper shredder.
2. Failure to comply with all safety and operating instructions can result in loss of machine control, serious personal injury to you and/or bystanders, and risk of equipment and property damage. The triangle in the text signifies important cautions or warnings which must be followed.



### WARNING

1. Engine exhaust, wood dust, and gasoline vapors from this product contains chemicals known to the state of California
2. To cause cancer, birth defects, or other reproductive harm.

# INDEX

Features .....	1
Specifications .....	1
Safety .....	2-4
Assembly .....	5-6
Operation .....	6-7
Transportating and Storage .....	8
Maintenance .....	8-10
Trouble Shooting .....	10
Repair .....	11
Parts Breakdown .....	12-14

## FEATURES

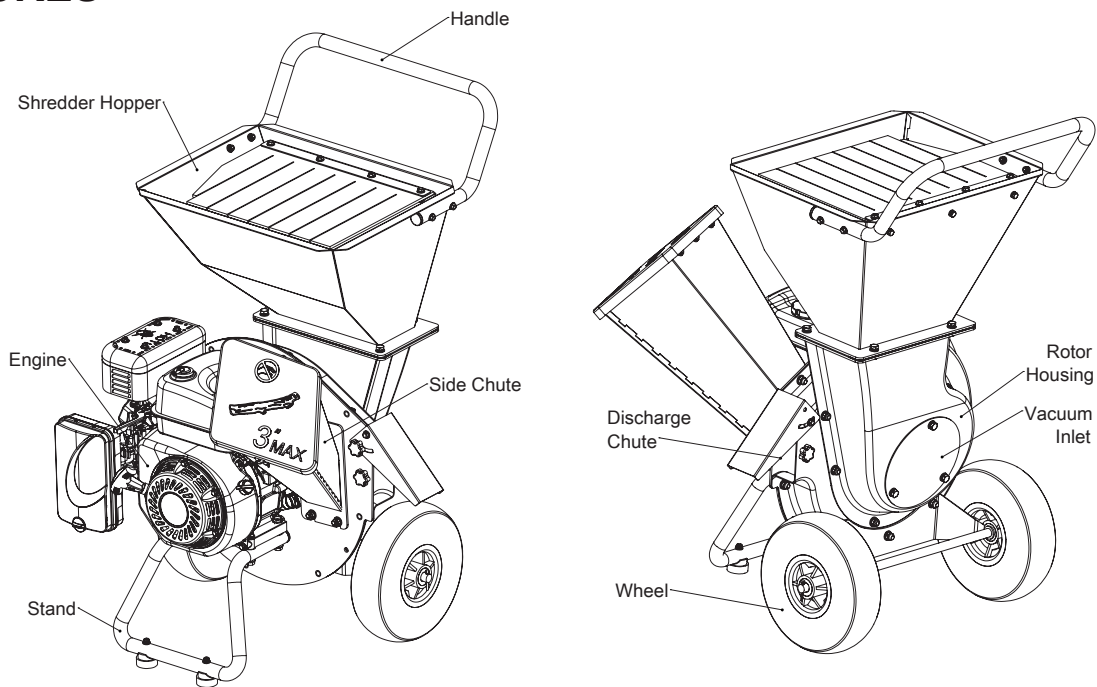

## SPECIFICATIONS

Item No.	PTG36212
Chipping Capacity	Max. 3"
Shredder Capacity	1/2"
Chipping Knives	2
Shredder Hammer	4 Y-HAMMERS
Reduction Rate	15:1
Hopper Dimensions (IN)	19.5X15.2
Limb Chute	YES
Wheel Size (IN)	10x2.5
Wheel Material	PU
Wheel Type	SOLID
Net Weight (LB)	121
Gross Weight (LB)	130
Assembled Dimension (IN)	29.5x25.7x40.6
Packing Dimension (IN)	33x24.8x24

# GENERAL OPERATING SAFETY

1. Read, understand, and follow all instructions in the manual and on the unit before starting
2. Locate the Chipper/Shredder on a flat, level, sturdy surface capable of supporting the weight of the Chipper / Shredder and any additional tools and equipment.
3. Do not attempt to use the machine on a slope or slick surface.
4. Dress appropriately when operating the chipper shredder. Always wear sturdy footwear and safety goggles. Never wear sandals, sneakers or open shoes, and never operate the chipper shredder with bare feet. Do not wear loose clothing that might get caught in moving parts.
5. Never place your hands, fingers, feet, or any other part of your body close to the Discharge Opening while the Chipper/Shredder is in operation.
6. Do not look into the Hopper, Chipper Chute or Discharge Opening when the machine is running.
7. Only allow responsible adults, who are familiar with the instructions, to operate the unit. Keep children away from the equipment, especially while it is operating.
8. Be sure the area is clear of other people before operating. Stop the unit if anyone enters the area.
9. Always maintain secure footing and solid balance while starting or operating the chipper shredder. Never lean directly over the machine.
10. Operate the machine only in daylight or good artificial light.
11. Do not operate the unit while under the influence of alcohol or drugs.
12. Always wear eye and hearing protection when operating this unit.
13. Keep in mind the operator is responsible for accidents occurring to other people or property.
14. Never operate the machine without proper guards, plates, or other safety protective devices in place.
15. Thoroughly inspect where equipment is to be used and remove all foreign objects.
16. Exercise extreme caution when operating on or crossing gravel drives, walks or roads. Stay alert for hidden hazards or traffic.

## PRODUCT SPECIFIC SAFETY

 **DANGER: The chipper shredder has spinning blades that can amputate hands and feet. Do not place hands or feet in the hopper or chipper cone, or discharge chute.**

 **WARNING: This unit discharges debris at high speeds. Always wear protective goggles and do not operate without the debris bag in place.**

Do not allow anyone in the area while the unit is running. If someone does enter the area, shut the unit off immediately until they leave. Organize the work area prior to starting work.

1. Do not operate without the debris bag in place because this unit discharges debris at high speeds. If the unit is operated on hard ground, asphalt, concrete, or other hard surfaces without the collection bag in place. Material can ricochet off of the hard surface and cause an unsafe condition for users and bystanders.
2. Never leave the machine running unattended. Always turn off the engine, wait for the rotor to come to a complete stop, and disconnect the spark plug before leaving the area. Always move the unit to a safe storage area when not in use.
3. Never direct discharge material toward anyone. Avoid discharging material against a wall or obstruction. Material may ricochet back toward the operator.
4. Always stand to the side of the chipper cone when feeding tree limbs and branches into the unit, as tree limbs, branches, and harder woods may kick back while being chipped.
5. Always keep hands out of the chipper cone and shredder hopper when feeding materials. Never wrap fingers tightly around branches as you are feeding them into the unit, as a sudden inward surge could pull your hands and arms into the unit.
6. Never allow material to build up in the discharge area or shredding chamber, as this may cause new material being fed into the machine to kickback with sufficient force to injure you or other bystanders.
7. Never allow material to build up around the engine during chipper shredder operation. This could result in a fire, or overheating of the engine.

8. Never attempt to reposition or move the chipper shredder unit while it is running. Doing so could cause the machine to tip over, and reaching to steady the unit could result in accidental insertion of your hands into the chipper cone or shredder hopper areas.
9. Never continue to operate the machine if it starts making unusual noise or vibration. Shut the engine off immediately, allow the rotor to stop, disconnect the spark plug wire and secure the wire away from the spark plug. Inspect the unit for any signs of damage or foreign material in the chipping or shredding areas. Remove any solid material that may be preventing the unit from operating properly.
10. Never attempt to clear clogs from the chipper cone, shredder hopper or discharge chute while the unit is running. Always shut the engine off, allow the rotor to come to a complete stop, and remove the spark plug wire from the spark plug before removing excess materials.
11. Never attempt to perform any maintenance, repairs, or attachment of accessories while the unit is running. Always shut the unit off, allow the rotor to come to a complete stop, and remove the spark plug wire from the spark plug before beginning these activities.
12. Always make sure that the shredding chamber, shredder hopper, and chipper cone are empty before starting the unit after it has been idle. Attempting to start the unit with material in these areas could cause the engine starting cord to stop suddenly, injuring your hand and fingers, or toppling the unit over. Vibration is generally a warning sign of trouble.
13. Use only attachments and accessories approved of by the manufacturer of the machine.
14. Make sure chipper shredder is free of debris before starting the engine.
15. Never attempt to make any adjustments while the engine is running.
16. After striking a foreign object, stop the engine, remove spark plug wire, and wait for all moving parts to come to a complete stop. Thoroughly inspect the machine for any damage, repair the damage before restarting and operating the machine.

## ENGINE SPECIFIC SAFETY

Before cleaning, repairing, or inspecting, shut off the engine and make certain that all moving parts have come to a complete stop. Disconnect the spark plug wire and secure the wire away from the spark plug to prevent accidental starting.



### **DANGER**

1. **Engines give off carbon monoxide, an odorless, colorless, poison gas. Carbon monoxide may be present even if you do not smell or see any engine exhaust. Breathing carbon monoxide can cause nausea, fainting or death, in addition to drowsiness, dizziness and confusion. If you experience any of these symptoms, seek fresh air and medical attention immediately.**
2. **If your machine comes with a separate engine manual, be sure to read and follow all safety and warning precautions outlined there, in addition to any in this manual.**

### **Handle fuel with care; it is highly flammable.**

- a. Use an approved fuel container.
- b. Never add fuel to a running engine or hot engine.
- c. Fill fuel tank outdoors with extreme care. Never fill fuel tank indoors.
- d. Replace gasoline cap securely and clean up spilled fuel before restarting.

### **Preventing Carbon Monoxide Poisoning**

1. Always start and run engine outdoors. Do not start or run engine in an enclosed area, even if doors or windows are open.
2. Never try to ventilate engine exhaust indoors. Carbon monoxide can reach dangerous levels very quickly.
3. Never run engine outdoors where exhaust fumes may be pulled into a building.
4. Never run engine outdoors in a poorly ventilated area where the exhaust fumes may be trapped and not easily taken away. (Examples include: in a large hole or areas where hills surround your working area.)
5. Never run engine in an enclosed or partially enclosed area. (Examples include: buildings that are enclosed on one or more sides, under tents, car ports or basements.)
6. Always run the engine with the exhaust and muffler pointed in the direction away from the operator.
7. Never point the exhaust muffler towards anyone. People should always be many feet away from the operation of the engine and its attachments.
8. Do not change the engine governor settings or over-speed the engine.
9. Do not operate the engine in a confined space where dangerous carbon monoxide fumes can collect.

## **Gasoline Fires and Handling Fuel Safely**

Use extra care in handling gasoline and other fuels. They are flammable and vapors are explosive.

1. When storing extra fuel be sure that it is in an appropriate container and away from any fire hazards.
2. Prevent fire and explosion caused by static electric discharge. Use only nonmetal, portable fuel containers approved by the Underwriter's Laboratory (U.L.) or the American Society for Testing & Materials.
3. Always fill fuel tank outside in a well ventilated area. Never fill your fuel tank with fuel indoors. (Examples include: basement, garage, barn, shed, house, porch, etc.) Never fill tank near appliances with pilot lights, heaters, or other ignition sources. If the fuel has to be drained, this should be done outdoors. The drained fuel should be stored in a container specifically designed for fuel storage or it should be disposed of carefully.
4. Never remove the fuel cap or add fuel with the engine running. Stop engine and allow to cool before filling.
5. Do not smoke while refueling or operating engine.
6. Never drain fuel from the engine in an enclosed area.
7. Always wipe up excess (spilled) fuel from engine before starting. Clean up spilled fuel immediately. If fuel is spilled, do not start the engine but move machine and fuel container from area. Clean up spilled fuel and allow to evaporate and dry after wiping and before starting.
8. Allow fuel fumes/vapors to escape from the area before starting engine.
9. Test the fuel cap for proper installation before starting and using engine.
10. Always run the engine with fuel cap properly installed on the engine.
11. During storage, keep machine so gas cap is up.
12. Never siphon fuel by mouth to drain fuel tank.
13. Always have an adult fill the fuel tank and never allow children to fill the engine.
14. Never allow an adult or anyone under the influence of drugs or alcohol to fill engine.
15. When storing gasoline or equipment with fuel in the tank, store away from furnaces, stoves, water heaters or other appliances that have a pilot light or other ignition source because they can ignite gasoline vapors.
16. Never fill containers inside a vehicle or on a truck bed with a plastic bed liner. Always place containers on the ground away from your vehicle before filling.
17. Remove gas-powered equipment from the truck or trailer and refuel it on the ground. If this is not possible, then refuel such equipment on a trailer with a portable container, rather than from a gasoline dispenser nozzle.

## **Burns and Fires**

The muffler, muffler guard and other parts of the engine become extremely hot during the operation of the engine. These parts remain extremely hot after the engine has stopped.

### **Prevention of Burns and Fires**

1. Never remove the muffler guard from the engine.
2. Never touch the muffler guard because it is extremely hot and will cause severe burns.
3. Never touch parts of the engine that become hot after operation.
4. Always keep materials and debris away from muffler guard and other hot parts of the engine to avoid fires.

## **Children and Bystanders**

Tragic accidents can occur if the operator is not alert to the presence of children and/or bystanders. Never assume that others will remain where you last saw them.

1. Keep the area of operation clear of all persons, especially small children and pets. Keep children under the watchful care of a responsible adult.
2. Be alert and turn the machine off if children enter the area.
3. Before and while moving backwards, look behind and down for small children.
4. Never allow children to operate the machine

# ASSEMBLY

## Install Stand (See Figure 1)

1. Position the stand (A) underneath the engine base
2. Using the four M8x60 flange bolts (C), and four flange nuts (D) to tight the stand with the engine base plate

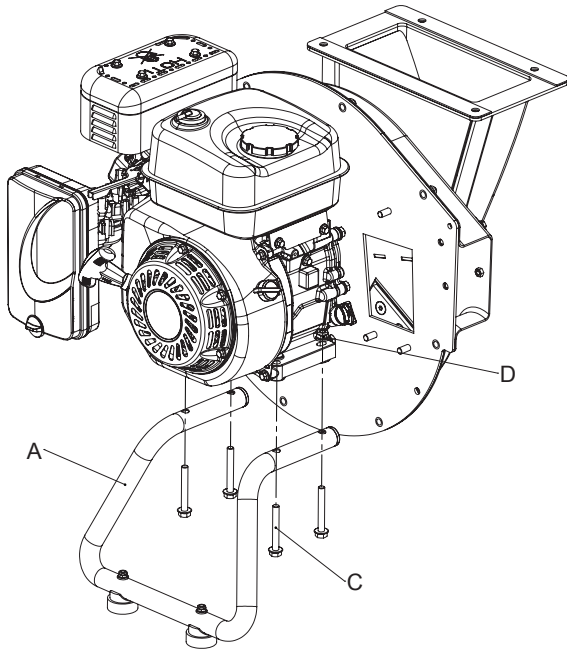

Figure 1

## Install the wheel rack and the wheels (See Figure 2)

1. Position the wheel rack over the three M8 thread studs protruding from the Rotor house. Attach the three M8 flange nuts (C) and tighten to secure the wheel rack
2. Put the wheel onto the axle (B), Make sure the wheel disc flat side face to outside.
3. Insert the spring pin (A) into the hole to secure the wheel on the axle.

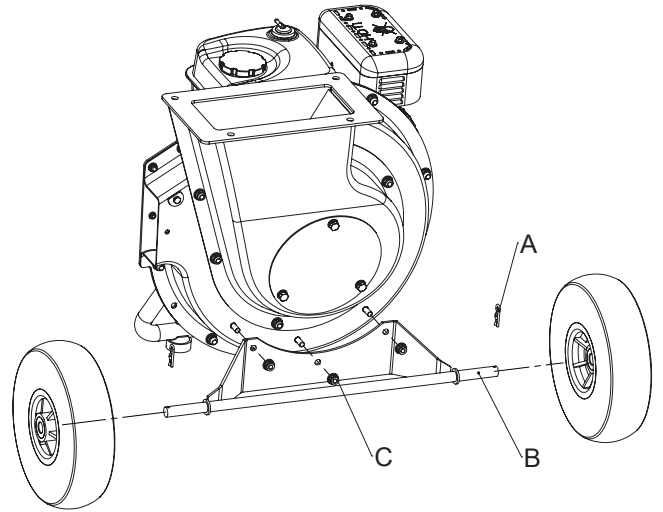

Figure 2

## Install Side Chute (See Figure 3)

1. Position the side chute (B) over the three M8 thread studs protruding from the engine plate
2. Attach the three M8 flange nuts (C) and tighten to secure the side chute
3. Rubber cover (A) can be used when using the vacuum function

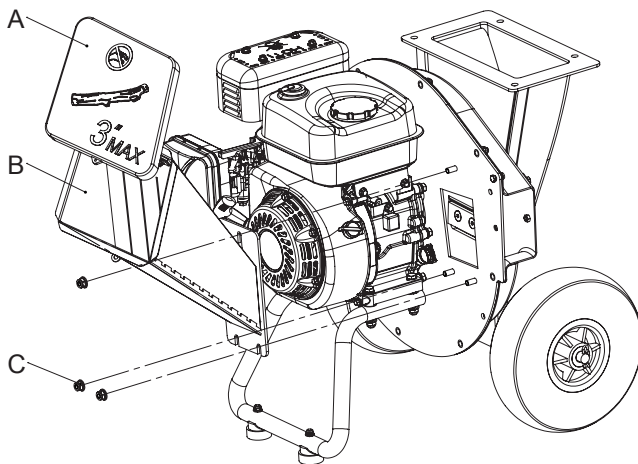

Figure 3

## Install the Handle (See Figure 4)

1. Position the handle (A) by aligning the handle holes with the hopper holes on two sides
2. Using four flange bolts (D), and flange nuts (C) to secure the handle on the hopper

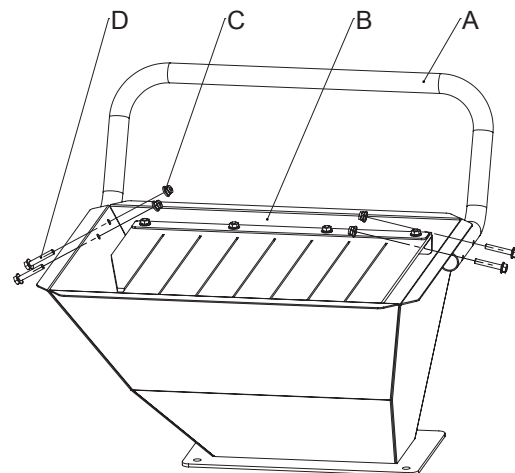

Figure 4

### Install the Hopper Guard (See Figure 5)

1. Position the hopper guard assembly (C) by aligning the assembly holes with the holes in the hopper
2. Using the three M6 flange bolts (A), spring washers (D) and washers (E) to secure the guard assembly (C) to the hopper.

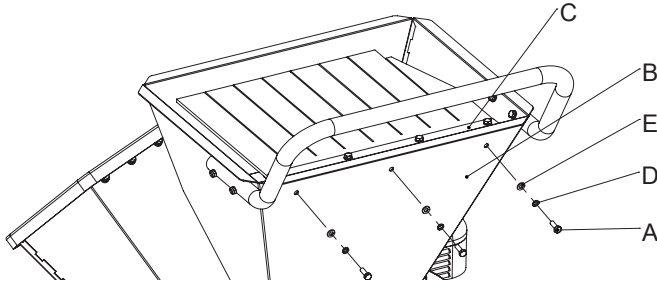

Figure 5

### Install the Hopper (See Figure 6)

1. Put the Backing plate(E) on the Chipper back cover and align the mounting holes.
2. Insert the plate(A) into the slot of the housing opening.
3. Position the hopper by aligning the assembly hole and fix by 4 M8x20 flange bolts(D), spring washer (C) and flat washer(B) to fix the hopper.

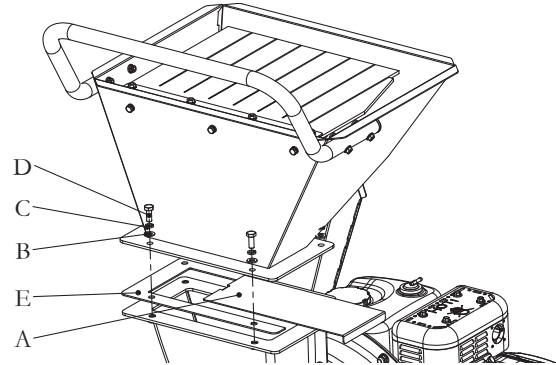

Figure 6

### Install the Suspender (See Figure 7)

1. Install the Suspender (A) into the sleeve on the Engine plate (B)
2. Insert the spring pin (C) into the hole to secure the Suspender on the Engine plate.

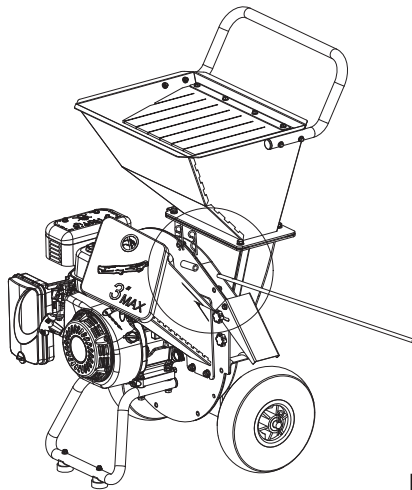

Figure 7

## GENERAL OPERATION

1. Be sure to read all information in the Safety and Operation sections before attempting to operate this unit. Become familiar with all of the controls and how to stop the unit.
2. Check all hardware (bolts, screws, etc) before every use for tightness to be sure machine is in safe working condition.
3. Overloading the equipment will shorten its life, and can cause mechanical failures.

### Chipper Operation

The chipper is designed to handle tree limbs and branches up to approximately 3" (7,6 cm) in diameter. The chipping knives also permit the processing of coarse organic matter like corn stalks. Tree branches must be inserted large-end first into the chipper cone. Since occasional kick-backs may occur, always stand off to the side of the unit. Allow the self-feeding action of the unit to draw the sticks in.

### Shredder Operation

The shredder is designed to shred light brush, leaves, and other soft but bulky organic waste. As material (no larger than 1/2 inch in diameter) is loaded into the shredder hopper it is pulled into the path of the hammers by air flow.



## Vacuum Attachment (Optional)

In addition to the chipper cone and hopper, loose debris may be processed by the Vacuum hose adapter kit. Leaves may be raked directly into the leaf tray where vacuum action will draw them into the shredder. For hard-to-reach areas, the nozzle and hose assembly may be used. The strength of the Vacuum may be changed using the rotating sleeve on the nozzle.

## Operating Location

1. Select an area with firm, level ground, covered by dirt or grass.
2. Do not operate on wet or slick surfaces, or near bystanders.
3. Locate and organize the materials to be processed so that you don't have to walk in front of the inlet or discharge openings, and so you have adequate room to work safely.

## Adding Oil

Refer to engine manual for information on adding oil.



### **DANGER**

1. The exhaust from this product contains carbon monoxide gas. Carbon monoxide is a colorless, odorless and tasteless gas that can cause dizziness, nausea, unconsciousness or even brain damage and death if inhaled for prolonged periods.
2. Operate the unit outdoors in a well ventilated location only. Keep children, pets and bystanders away.
3. Failure to follow these instructions may result in serious injury or death.



### **WARNING**

1. Gasoline is highly flammable and must be handled with care. Never fill the tank when the engine is still hot from recent operation.
2. Do not allow open flame, smoking or matches in the area. Avoid over-filling and wipe up any spills.



**WARNING: To avoid serious personal injury from rotating cutting blades, keep hands out of inlet while machine is running.**



**WARNING: Do Not Use Gasoline Containing Methanol, Gasohol Containing More Than 10% Ethanol, Gasoline Additives Or White Gas Because Engine/fuel System Damage Could Result.**



**IMPORTANT: Engine is shipped from factory without oil. You must add engine oil before starting engine.**

## Adding Fuel

To add fuel:

1. Remove the fuel cap.
2. Fill the tank. Do not overfill. Leave room in the tank for fuel expansion. Refer to your engine manual for specific fuel recommendations.
3. Install and hand tighten the fuel cap.

## Starting the Engine

1. See engine manual for starting up instructions.
2. Ensure engine is running full throttle before beginning chipping operation. On some engines, the throttle may not be adjustable.

## Stopping the Engine

1. See engine manual for shut down procedure.
2. Stopping the engine is the only way to stop the rotor from turning. With engines equipped with an adjustable throttle, move the throttle to the SLOW position and wait for engine to be running a slow RPM. Then switch to STOP ENGINE as shown in the engine manual.

## TRANSPORTING AND STORAGE

1. Always observe safe refueling and fuel handling practices when refueling the unit after transportation or storage.
2. Never store the unit (with fuel) in an enclosed poorly ventilated structure. Fuel vapors can travel to an ignition source (such as a furnace, water heater, etc.) and cause an explosion. Fuel vapor is also toxic to humans and animals.
3. Always use the hopper handle and built-in wheels to move the chipper shredder. Never lift the unit using the fuel tank for support. If the unit must be lifted, always use at least two people, and always grip the unit securely using the front leg and hopper handle.
4. Always follow the engine manual instructions for storage preparations before storing the unit for both short and long term periods.
5. Always follow the engine manual instructions for proper start-up procedures when returning the unit to service.
6. Never store the unit or fuel container inside where there is an open flame or pilot light, such as in a water heater. Allow unit to cool before storing.

### Storage

Perform engine maintenance and storage measures listed in the engine owner's manual. This includes draining the fuel system, or adding stabilizer to the fuel. **NOTE: Do not store a fueled unit in an enclosed structure. (SEE GASOLINE FIRES AND HANDLING FUEL SAFETY)**

### Before starting the unit after it has been stored:

1. Check all fluid levels. Check all maintenance items.
2. Perform all recommended checks and procedures found in the engine owner's manual.
3. Allow the engine to warm up for several minutes before use.

## MAINTENANCE

### Schedule & Procedures

The following schedule should be followed for normal care of your unit.

SAFETY ITEMS	BEFORE EACH USE	EVERY 5 HOURS	EVERY 25 HOURS	EVERY 100 HOURS	EVERY 250 HOURS	SPRING & FALL
Check for loose hardware		X				X
Check all safety labels						X
Inspect cone, hopper, and guards	X					X
<b>CHIPPER MAINTENANCE ITEMS</b>						
Clean debris from engine and chipper	X					
Inspect/Rotate Shredding Hammers			X			
Inspect/Rotate Chipping Knives			X			

### Engine Maintenance

Refer to the engine manual included in your package for information on engine maintenance. Your engine manual provides information and a maintenance schedule for performing the following tasks:

1. Always check oil level before starting engine. Refer to engine manual for capacity and type of oil to use.
2. Change oil after first 5-8 hours of operation. Change oil while engine is warm. Refill with new oil of recommended grade.
4. Check spark plug yearly or every 50 hours of operation.
5. Service air cleaner.
6. Keep engine and parts clean.
7. Check engine and equipment often for loose nuts and bolts, keep these items tightened.

### Check for Loose Hardware

1. Service Interval: Every 5 hours; every spring and fall.
2. Inspect the unit, checking for loose hardware or components.
3. Pay special attention to the hardware attaching the chipper cone, hopper, axle, and front leg.

## Check Safety Labels

1. Service Interval: Every spring and fall.
2. Check that the safety labels are in place and undamaged.
3. Sample illustrations and part numbers of the decals can be found on page 6. Replace any damaged or missing decals.

## Inspect Cone, Hopper, & Guards

1. Service Interval: Every spring and fall.
2. Check that the chipper cone, shredder hopper, and discharge guards are in place, undamaged, and secure. Replace any damaged or missing parts.

## Clean Debris from Engine & Chipper

1. Service Interval: Before each use and every 100 hours.
2. The engine requires air flow to cool itself and for combustion.
3. Before each use, clean any debris from the unit especially from around the air shroud intake, air filter, and muffler. Every 100 hours, remove the engine air shroud and clean out any debris from the engine cooling fins. We recommend having this service performed by an authorized dealer.

## Inspect / Rotate Shredding Hammers (See Figure 7)

Service Interval: Every 25 Hours, or As Necessary  
The shredding hammers of this unit can be rotated to provide a new cutting surface as required.

The Y hammers can be flipped over once.

To inspect the shredding hammers:

1. Disconnect the spark plug wire and secure it away from the spark plug.
2. Remove the small circular access panel (B) from the back of the shredder housing. SEE FIGURE 7
3. Inspect the cutting edges of the Y-hammers (A).

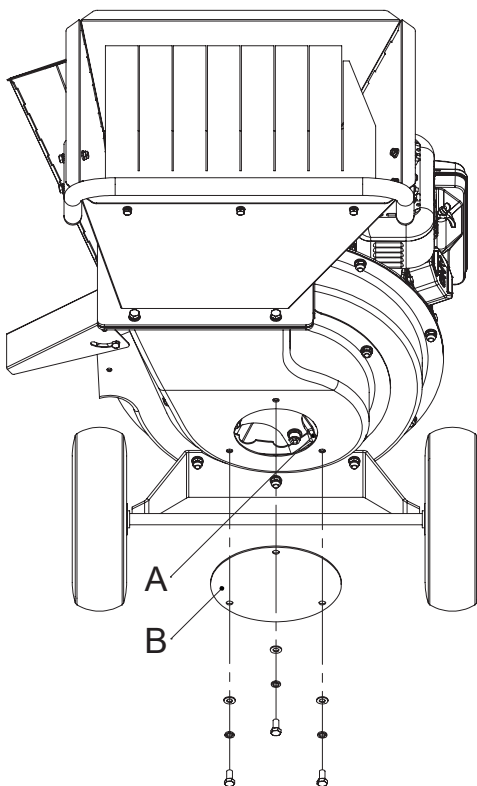

Figure 7

## Inspect Chipping Knives (See Figure 8)

Service Interval: Every 25 hours, or as necessary

The chipping knives of this unit can be rotated or sharpened to provide a new cutting surface as required. When inspecting the knives be careful to avoid touching the sharpened edges. To inspect the chipping knives:

1. Disconnect the spark plug wire and secure it away from the spark plug.
2. Remove the nuts securing the side chute to the front of the chipper. Remove the side chute to access the knives. SEE FIGURE 8
3. Using the recoil starter, slowly pull the starter rope to rotate the rotor into position so the blades can be seen. To sharpen or replace the chipper knives, see the Troubleshooting and Repair section.

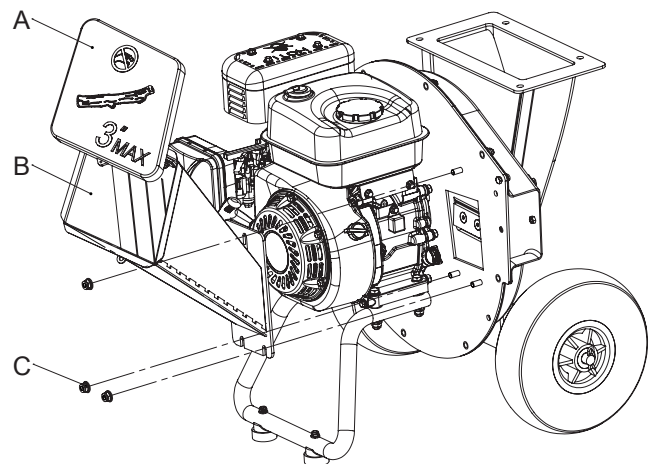

Figure 8

 **IMPORTANT: Engine is shipped from factory without oil. You must add engine oil before starting engine.**

 **CAUTION**

1. For the safety of the user, and to maximize the life of the engine, it is crucial to take time to check the condition of the engine.
2. Problems must be corrected before operating.
3. Avoid injury! Engine oil is hazardous to your health. Dispose of oil appropriately.
4. Use a safe disposal/recycling center.

## TROUBLESHOOTING CHART

1. While normal care and regular maintenance will extend the life of your equipment, prolonged or constant use may eventually require that service be performed to allow it to continue operating properly.
2. The troubleshooting guide below lists the most common problems, their causes, and remedies.
3. See the information on the following pages for instructions on how to perform most of these minor adjustments and service repairs yourself. If you prefer, all of these procedures can be performed for you by your local authorized dealer.

 **WARNING**

1. To avoid serious injury, perform maintenance on the unit only when the engine is stopped.
2. Always disconnect the spark plug wire and fasten it away from the plug before beginning the maintenance, to prevent accidental starting of the engine.

Problem(s)	Possible Cause	Corrective Action
Engine won't start	<ol style="list-style-type: none"> <li>1. No fuel.</li> <li>2. Choke not in START position.</li> <li>3. Low quality or deteriorated, old gasoline.</li> <li>4. Dirty fuel passageways.</li> <li>5. Spark plug cap not connected securely.</li> <li>6. Spark plug fouled.</li> <li>7. No compressions. Problem after long storage periods.</li> <li>8. Low engine oil.</li> </ol>	<ol style="list-style-type: none"> <li>1. Add fuel.</li> <li>2. Turn choke to START position.</li> <li>3. Use fresh unleaded gasoline.</li> <li>4. Clean out passageways using fuel additive. Heavy deposits may require further cleaning.</li> <li>5. Connect spark plug cap properly.</li> <li>6. Remove spark plug. Clean/replace as recommended in engine manual.</li> <li>7. Lubricate the cylinder, pour tablespoon of oil into spark plug hole. Crank engine a few times and try to start again.</li> <li>8. Add engine oil to proper level.</li> </ol>
Engine exhaust is black	<ol style="list-style-type: none"> <li>1. Dirty air filter.</li> <li>2. Choke closed.</li> </ol>	<ol style="list-style-type: none"> <li>1. Replace air filter.</li> <li>2. Open choke.</li> </ol>
Engine stops suddenly	<ol style="list-style-type: none"> <li>1. Fuel tank empty or full of impure or low quality gasoline.</li> <li>2. Low oil shutdown.</li> <li>3. Disconnected or improperly connected spark plug cap.</li> <li>4. The limb is too long.</li> </ol>	<ol style="list-style-type: none"> <li>1. Add fuel tank with fresh unleaded gasoline.</li> <li>2. Fill engine oil to proper level.</li> <li>3. Secure spark plug cap.</li> <li>4. If the limb diameter for the side chute in 2"-3" and the length over 31" long, suggest the operator should help the limb feeding by slightly holding to keep the rotate speed.</li> </ol>
Engine runs but no material is discharged	<ol style="list-style-type: none"> <li>1. Discharge chute clogged.</li> <li>2. Engine not running at full speed.</li> </ol>	<ol style="list-style-type: none"> <li>1. Clean out debris.</li> <li>2. Set throttle control to FAST if equipped.</li> </ol>
Chipping action slow, or engine stalling	<ol style="list-style-type: none"> <li>1. Branch diameter is too thick.</li> <li>2. Throttle set is too slow.</li> <li>3. Tree limbs are extremely hard or dried out.</li> </ol>	<ol style="list-style-type: none"> <li>1. Do not process branches over 3" diameter.</li> <li>2. Adjust throttle to increase engine speed.</li> <li>3. Material is not suitable for chipping.</li> </ol>
Unusual noise or vibration when chipping material	<ol style="list-style-type: none"> <li>1. Rotor overloaded with material.</li> <li>2. Hammers are broken, bent, or loose.</li> <li>3. Hammers frozen in place.</li> </ol>	<ol style="list-style-type: none"> <li>1. Allow unit to clear itself before adding more material to the hopper.</li> <li>2. Check assembly. Tighten or replace as necessary.</li> <li>3. Check for obstructions and debris. Repair or replace as necessary.</li> </ol>
Vacuum not working.	<ol style="list-style-type: none"> <li>1. Hopper gate not closed.</li> <li>2. Cone cover not installed.</li> <li>3. Hose not attached properly.</li> <li>4. Engine not running at full RPM.</li> </ol>	<ol style="list-style-type: none"> <li>1. Slide gate to closed position.</li> <li>2. Allow material to dry.</li> <li>3. Clear blockage or replace.</li> <li>4. Set throttle control to FAST if equipped.</li> </ol>

# REPAIR

## Shredding Hammer Rotation and Replacement

The cutting edges of the shredding hammers may eventually wear out requiring rotation of the hammer or replacement if all cutting edges have been dulled.

### To rotate the shredding hammers:

1. Turn the engine off and wait for all moving parts to stop.
2. Disconnect the spark plug wire and secure it away from the spark plug.
3. Detach the rotor housing and hopper from the rotor plate. SEE FIGURE 9
4. Note the assembly sequence of the hardware used to secure the hammers. Using an allen wrench remove the socket head cap screw (A) and related hardware. SEE FIGURE 10
5. Inspect the hammers (D), spacer tubes (E), and hardware. If the spacer tube (E) shows signs of wear, replace it. Inspect and flip, or replace the hammers (D).
6. Reassemble the hammers, spacers, washers, and cap screws. Torque the socket head cap screws (A) back tightly
7. Repeat for all the hammers.

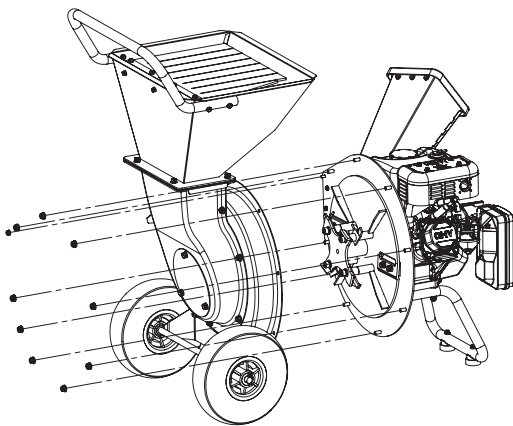

Figure 9

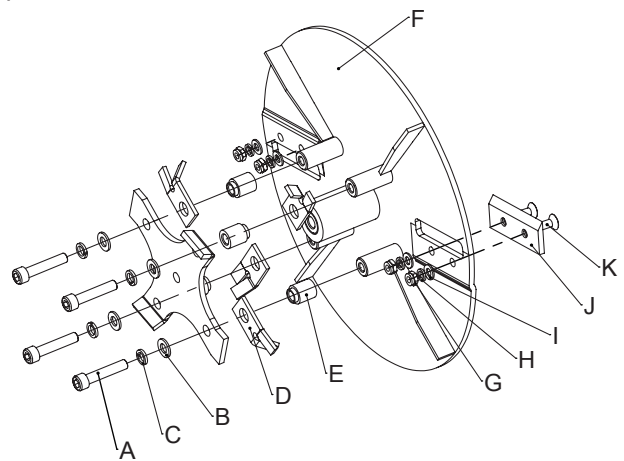

Figure 10

## Chipping Knives Sharpening and Replacement

1. The chipping knives should be sharpened or replaced when tree limbs require extra force to feed into the chipper cone.
2. The chipping knives may be sharpened at a 39 degree angle until the distance between the edge of the blade bevel and the mounting hole is less than 1/16" (1.6mm). SEE FIGURE 13.

### To inspect, sharpen, or replace the chipping knives:

1. Turn the engine off and wait for all moving parts to stop.
2. Disconnect the spark plug wire and secure it away from the spark plug.
3. Detach the rotor housing and hopper from the rotor plate. SEE FIGURE 9
4. Remove the rotor by removing the hardware that secures it to the engine crank shaft. SEE FIGURE 11. NOTE: Do not lose spacer. During reassembly Be sure to place spacer is installed inside rotor. Without spacer, rotor will interfere with housing components.
5. Using a hex wrench, remove the two socket head cap screws and the chipper knife. SEE FIGURE 12
6. Inspect, rotate, sharpen, or replace the chipper knife. SEE FIGURE 13
7. Reinstall the chipper knife and tighten the socket head cap screws

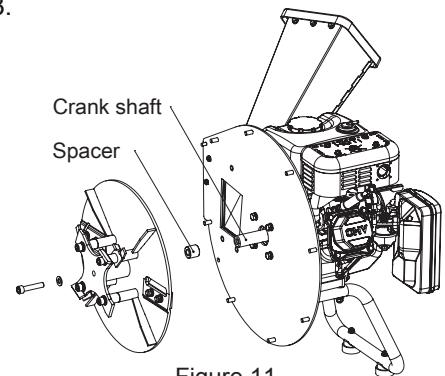

Figure 11

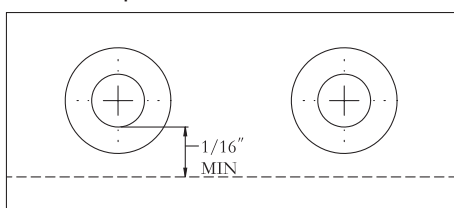

Figure 13- Chipper knife minimum cutting edge

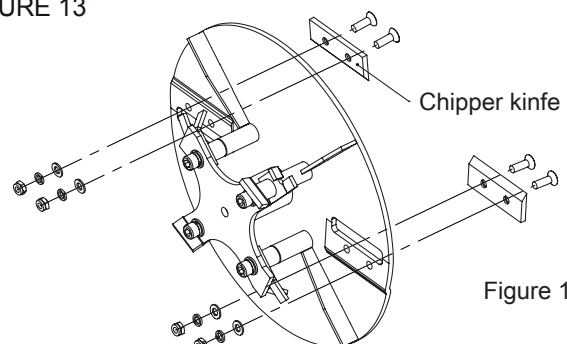
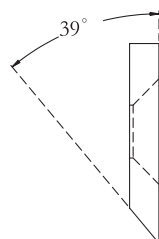
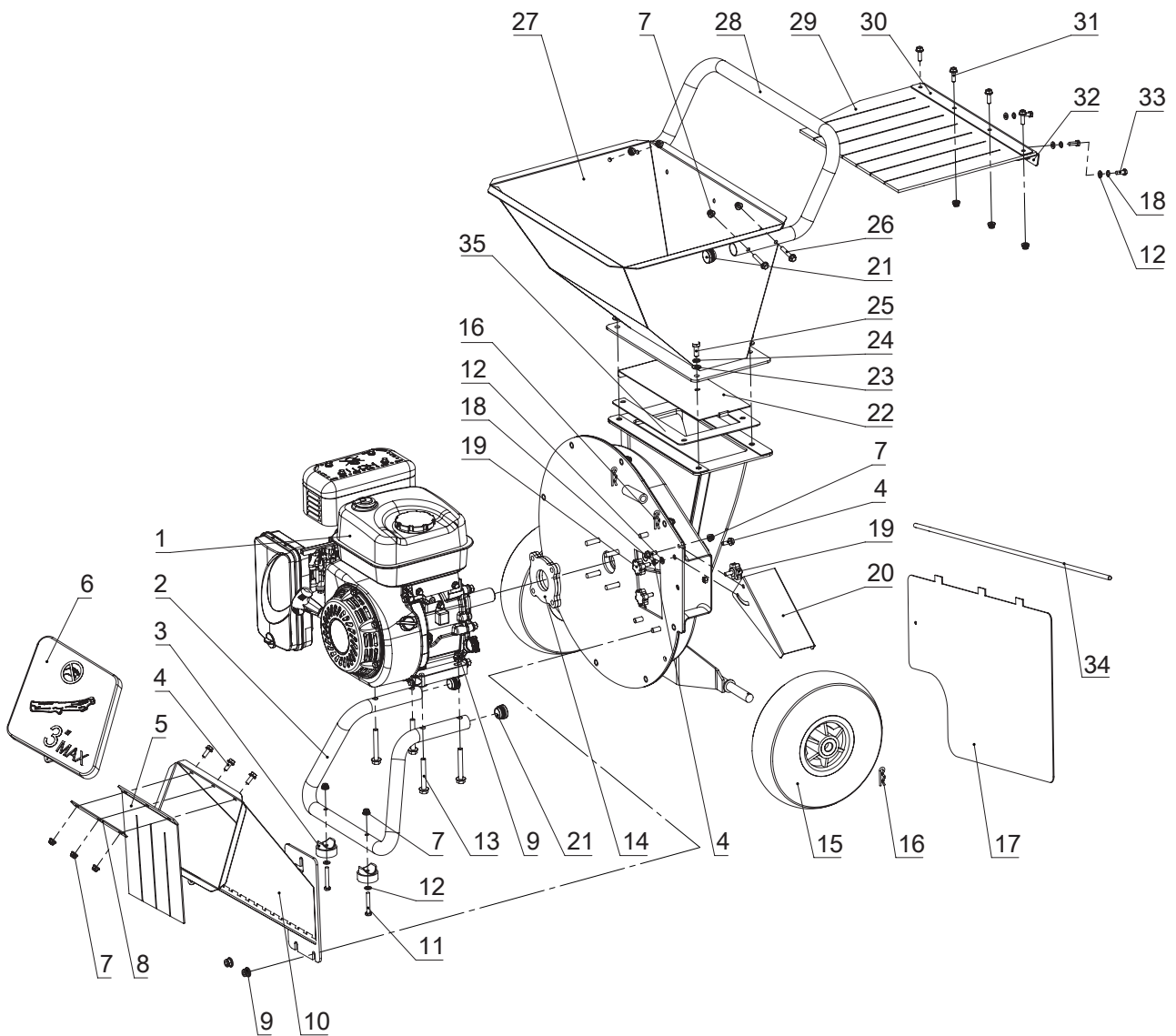

Figure 12

# PARTS BREAKDOWN



Part No.	Description	Q'ty	Part No.	Description	Q'ty
1	Engine	1	19	Handwheel	3
2	Support stand	1	20	Discharge guard	1
3	Stand pad	2	21	End Cap	4
4	Flange Bolt M6x16	5	22	Damper	1
5	Guard	1	23	Washer 8	15
6	Rubber cover	1	24	Spring washer 8	15
7	Flange nut M6	15	25	Bolt M8x20	4
8	Retainer hopper guard	1	26	Flange Bolt M6x35	4
9	Flange nut M8	24	27	Hopper	1
10	Side Clute	1	28	Handle	1
11	Socket Cap Screw M6x40	2	29	hopper Guard	1
12	Washer 6	8	30	Retainer hopper guard	1
13	Flange Bolt M8x60	4	31	Flange Bolt M6x20	4
14	Flange	2	32	Flange hopper guard	1
15	Wheel	2	33	Bolt M6x16	3
16	Spring pin	4	34	Suspender	1
17	Bag	1	35	Backing plate	1
18	Spring washer 6	6			

## Parts Breakdown – Engine and Rotor Group

Part No.	Description	Q'ty
1	Engine	1
2	Flange	2
3	Engine plate	1
4	Spring washer 8	4
5	Hex bolt	4
6	Key parallel pin	1
7	Bearing spacer	1
8	Rotor assembly kit	1
9	Washer	1
10	Hex head bolts	1
11	Washer 8	4

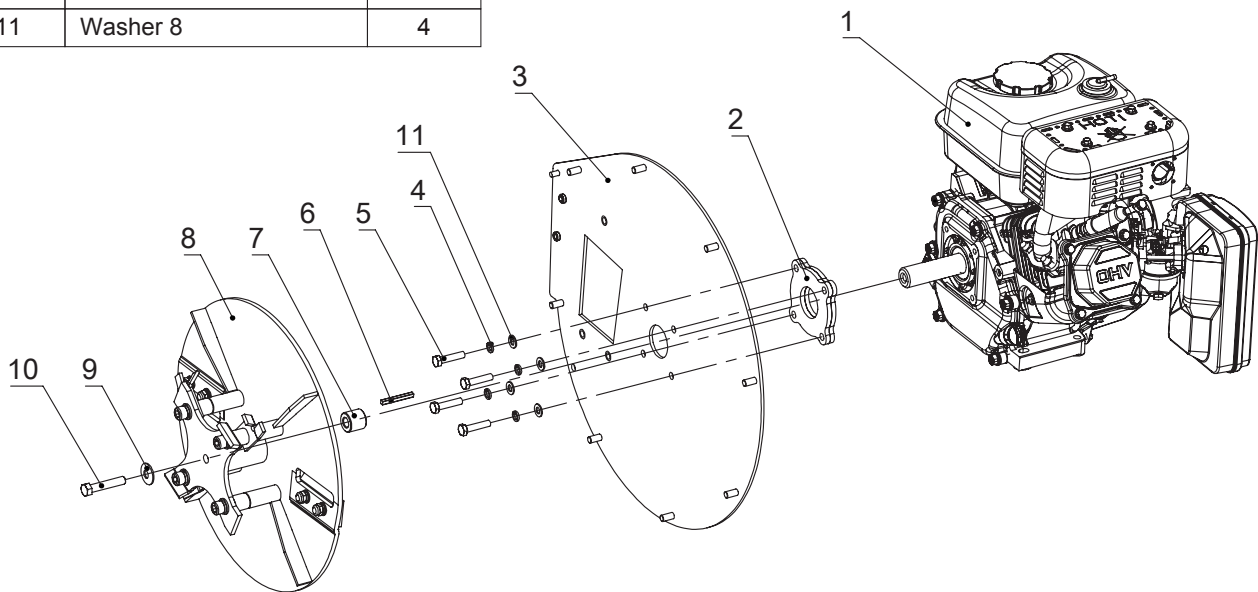

## Parts Breakdown – Rotor Group

Part No.	Description	Q'ty
1	Socket head cap screw M10x50	4
2	Spring washer 10	4
3	Washer 10	4
4	Y hammer	4
5	Bearing sleeve	4
6	Knives plate	1
7	Locknut M8	4
8	Spring washer 8	4
9	Washer 8	4
10	Knife	2
11	Screw	4

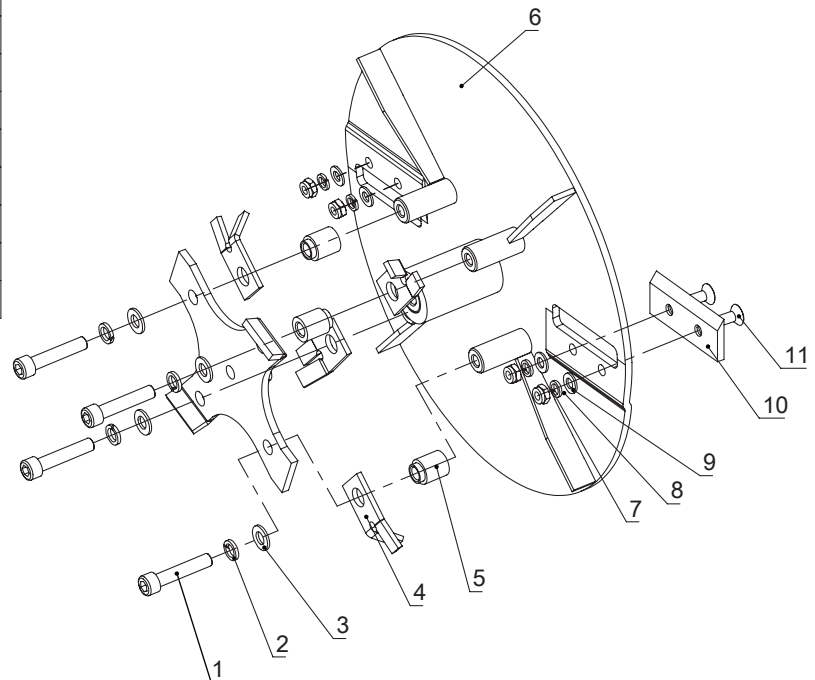

## PARTS BREAKDOWN - CHIPPER HOUSING GROUP

Part No.	Description	Q'ty
1	Engine plate	1
2	Rotor assembly kit	1
3	Rotor house	1
4	Chipper back cover	1
5	Hex bolt M6x16	1
6	Flange nut M8	18
7	Vacuum inlet cover	1
8	Hex bolt M8x16	3
9	Spring washer	3
10	Washer	3
11	Wheel rack	1
12	Flage nut M6	1

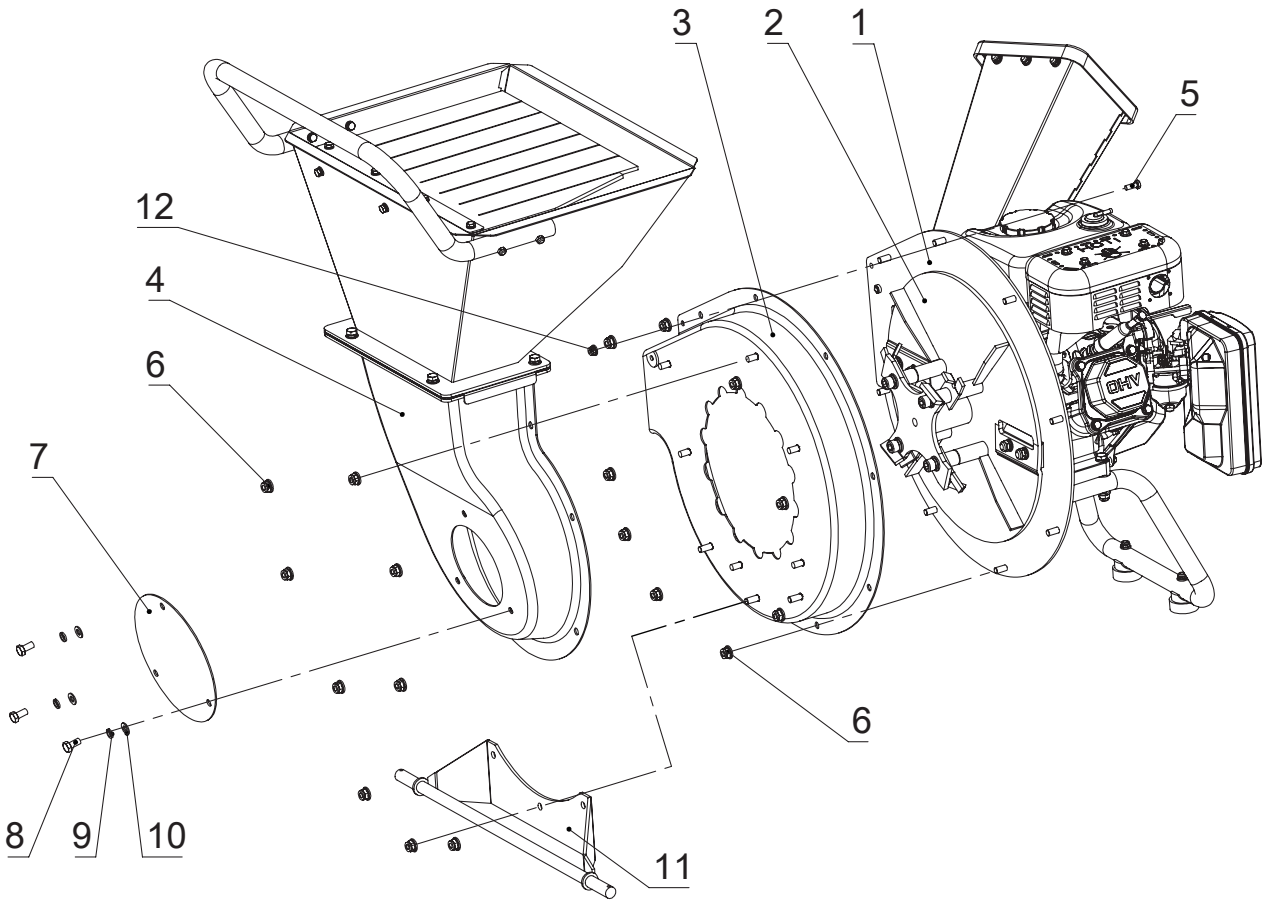

## TROUBLE SHOOTING:

PROBLEM	POSSIBLE CAUSE	SOLUTIONS
Vacuum not working	1. Hopper gate not closed.	1. Slide gate to closed position.
	2. Cone cover not installed.	2. Install the cone cover.
	3. Hose not attached properly.	3. Clear blockage or replace.
	4. Engine not running at full RPM.	4. Set throttle control to FAST if equipped.