

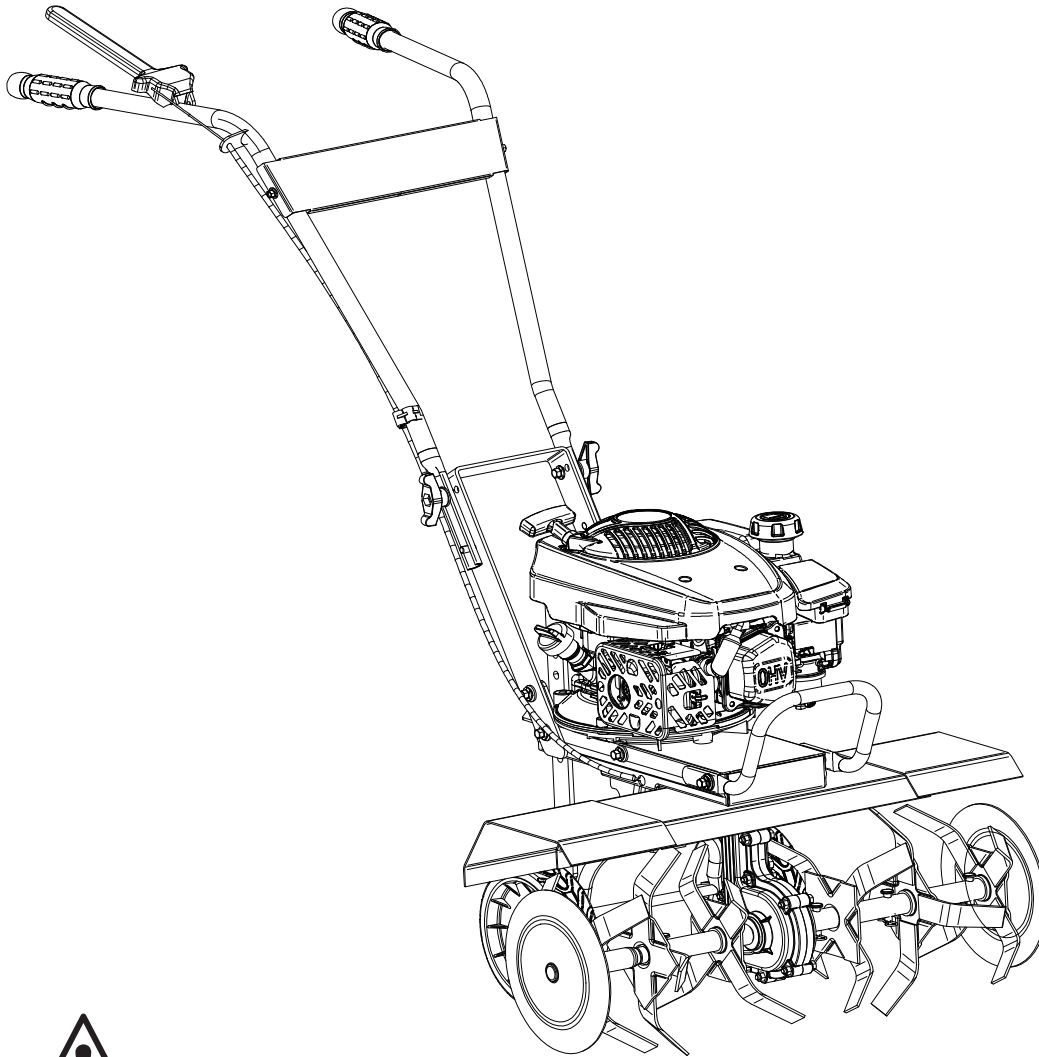

Model#PTG1121HD

# Front Tine Tiller OPERATOR'S MANUAL



Warning: The Engine Exhaust from this product contains chemicals known to the State of California to cause cancer, birth defects or other reproductive harm.

|  |  |
|--|--|
|  | <b>DO NOT RETURN TO STORE!</b>         |
|  | <b>HAVE QUESTIONS OR NEED SERVICE?</b> |
|  | 866-591-8921                           |
|  | support@pulsar-products.com            |

# Table of Contents

|                          |   |
|--------------------------|---|
| Safety Information ..... | 2 |
| Pre-Assembly .....       | 6 |
| Planning Assembly .....  | 6 |
| Tools Required .....     | 6 |
| Hardware Included .....  | 6 |
| Package Contents .....   | 6 |

|                                  |    |
|----------------------------------|----|
| Assembly .....                   | 7  |
| Operation .....                  | 9  |
| Maintenance .....                | 14 |
| Care, Cleaning and Storage ..... | 17 |
| Troubleshooting .....            | 18 |
| Service Parts .....              | 19 |

## Safety Information

### GENERAL SAFETY

Read this operator's manual carefully in its entirety before attempting to assemble this machine. Read, understand, and follow all instructions on the machine and in the manual(s) before operation. Keep this manual in a safe place for future and regular reference and for ordering replacement parts.

- Be completely familiar with the controls and the proper use of this machine before operating it.
- This machine is a precision piece of power equipment. Therefore, exercise extreme caution at all times.
- Regularly inspect the tiller. Make sure parts are not bent, damaged, or loose.
- Use this equipment for its intended purpose only.
- Operate the unit only with guards, shields, and other safety items in place and working correctly.
- Service the unit only with authorized or approved replacement parts.
- Complete all unit maintenance and adjustments according to the instructions in this manual.
- To prevent accidental starting when setting up, transporting, adjusting or making repairs, always disconnect spark plug wire.
- Be thoroughly familiar with the controls and the proper use of the tiller before starting. Know how to stop the engine quickly.



**DANGER:** Indicates an imminently hazardous situation which, if not avoided, will result in death or serious injury.



**WARNING:** Indicates a potentially hazardous situation which, if not avoided, could result in death or serious injury.



**CAUTION:** Indicates a potentially hazardous situation which, if not avoided, may result in minor or moderate injury.



**IMPORTANT:** Indicates operation or maintenance information which is important but not hazard-related.

**NOTICE:** Indicates a practice not related to personal injury which, if not avoided, may result in property damage.

- To help avoid tiller tines contact or a thrown object injury, stay in operator zone behind handles and keep children, bystanders, helpers and pets at least 75 feet from tiller while it is in operation. Stop machine if anyone enters area.
- Always wear safety glasses or safety goggles during operation and while performing an adjustment or repair to protect your eyes. Thrown objects which ricochet can cause serious injury to the eyes.
- Wear sturdy, rough-soled work shoes and close-fitting pants and shirts. Shirts and pants that cover the arms and legs and steel-toed shoes are recommended. Never operate this machine while barefoot, in sandals, slippery or lightweight (e.g. canvas) shoes.

## Safety (continued)

### GENERAL SAFETY

- Do not put hands or feet near or under rotating parts. Keep clear of discharge area at all times as the rotating tines can cause injury.
- Never operate the tiller without proper shields, guards, control lever or other safety protective devices in place and working.
- Never operate the tiller with damaged safety devices. Failure to do so, can result in personal injury.
- Familiarize yourself with all the safety and operating decals on this equipment.
- Thoroughly inspect the area where the tiller is to be used and remove all foreign objects. Your equipment can propel small objects at high speed causing personal injury or property damage.
- Check that all nuts and bolts are tight and equipment is in good condition before each use.
- Never allow children or young teenagers to operate the tiller.
- Only allow responsible individuals, who are familiar with the instructions, to operate the tiller.
- Do not operate the tiller while under the influence of alcohol or drugs.
- The control lever is a safety device. Never attempt to bypass its operation. Doing so makes the safety device inoperative and may result in personal injury through contact with the rotating tines. The control lever must operate easily in both directions and automatically return to the disengaged position when released.
- Do not put hands or feet near or under rotating parts.
- Operate only in daylight or good artificial light. Walk, never run.
- Exercise extreme caution when operating on or crossing gravel drives, walks, or roads. Stay alert for hidden hazards or traffic.
- Exercise caution to avoid slipping or falling. Always be sure of your footing; keep a firm hold on the handle and walk; never run. Never operate the tiller at high transport speeds on slippery surfaces.
- If the equipment should start to vibrate abnormally, stop the engine and check immediately for the cause. Vibration is generally a warning of trouble.
- Never leave the tiller unattended when the engine is running. Stop the engine and make sure all moving parts have stopped. Remove the wire from the spark plug.
- Muffler and engine become hot and can cause a burn. Do not touch.
- Do not run the engine indoors or inside a closed area. The exhaust fumes are dangerous, containing CARBON MONOXIDE, an ODORLESS AND DEADLY GAS.
- Watch for holes, roots, bumps, or other rough ground. Tall grass can hide obstacles.
- Always look behind and down and use caution when using reverse or pulling the tiller towards you.
- Never attempt to start the tiller unless both wheels are in the locked position. This acts as a brake for the tiller.
- Always start the tiller on the level surface.
- Only use parts and accessories made for this machine by the manufacturer. Failure to do so can result in personal injury.
- When starting engine, pull cord slowly until resistance is felt, then pull rapidly. Rapid retraction of starter cord (kickback) will pull hand and arm toward engine faster than you can let go. Broken bones, fractures, bruises or sprains could result.
- Disengage clutch lever and stop engine before leaving the tiller in operating position. Wait until the tines come to a complete stop before removing debris or making any adjustments to the tiller.
- Do not attempt to till hard soil, till too deep or till at too fast a rate that can overload the tiller.
- Gasoline is extremely flammable, and gasoline vapors can explode if ignited. Handle with care.
- Use an approved container.

# Safety (continued)

## GENERAL SAFETY

- Always be sure of your footing. A slip and fall can cause serious personal injury. If you feel you are losing your balance, release the control lever immediately and the tine will stop rotating.
- Do not till near drop-offs, ditches or embankments, you could lose your footing or balance.

## CHILDREN SAFETY

Tragic accidents can occur if the operator is not alert to the presence of children. Children are often attracted to the tiller. They do not understand the dangers. Never assume that children will remain where you last saw them.

- Keep children out of the tilling area and under watchful care of a responsible adult other than the operator.
- Be alert and turn tiller off if a child enters the area.
- Before and while moving backwards, look behind and down for small children.
- Use extreme care when approaching blind corners, doorways, shrubs, trees, or other objects that may obscure your vision of a child who may run into the tiller.
- Keep children away from hot or running engines. They can suffer burns from a hot muffler.
- Never allow children to operate this machine.

## SAFETY WHILE SERVICING

### Safe Handling Of Gasoline:

- To avoid personal injury or property damage use extreme care in handling gasoline. Gasoline is extremely flammable and the vapors are explosive. Serious personal injury can occur when gasoline is spilled on yourself or your clothes, which can ignite. Wash your skin and change clothes immediately.
- Use only an approved gasoline container.
- Never fill containers inside a vehicle or on a truck or trailer bed with a plastic liner. Always place containers on the ground away from your vehicle before filling.

- Remove gas-powered equipment from the truck or trailer and refuel it on the ground. If this is not possible, then refuel such equipment on a trailer with a portable container, rather than from a gasoline dispenser nozzle.
- Keep the nozzle in contact with the rim of the fuel tank or container opening at all times until fueling is complete. Do not use a nozzle lock-open device.
- Extinguish all cigarettes, cigars, pipes and other sources of ignition.
- Never fuel machine indoors because flammable vapors will accumulate in the area.
- Never remove gas cap or add fuel while engine is hot or running. Allow engine to cool at least two minutes before refueling.
- Never over fill fuel tank. Fill tank to no more than 1 inch below bottom of filler neck to provide for fuel expansion.
- Replace gasoline cap and tighten securely.
- If gasoline is spilled, wipe it off the engine and equipment. Move machine to another area. Wait 5 minutes before starting engine.
- Never store the machine or fuel container near an open flame, spark or pilot light as on a water heater, space heater, furnace, clothes dryer or other gas appliances.
- To reduce fire hazard, keep machine free of grass, leaves, or other debris build-up. Clean up oil or fuel spillage and remove any fuel soaked debris.
- Allow machine to cool at least 5 minutes before storing.
- Never run an engine indoors or in a poorly ventilated area. Engine exhaust contains carbon monoxide, an odorless and deadly gas.
- If situations occur which are not covered in this manual, use care and good judgement. Contact Customer Support for assistance or the name of the nearest service dealer.

## Safety (continued)

### GENERAL SAFETY

- Before cleaning, repairing, or inspecting, make certain the tines and all moving parts have stopped. Disconnect the spark plug wire and ground against the engine to prevent unintended starting.
- Check the tines and engine mounting bolts at frequent intervals for proper tightness. Also, visually inspect tines for damage. Replace with the original equipment manufacturer's (O.E.M.) parts only, listed in this manual. "Use of parts which do not meet the original equipment specifications may lead to improper performance and compromise safety!"
- Keep all nuts, bolts, and screws tight to be sure the equipment is in safe working condition.
- Never tamper with safety devices. Check their proper operation regularly.
- After striking a foreign object, stop the engine, disconnect the spark plug wire and ground against the engine. Thoroughly inspect the tiller for any damage. Repair the damage before starting and operating the tiller.
- Tiller components, guards and shields are subject to wear and damage which could expose moving parts or allow objects to be thrown. For safety protection, frequently check components and replace immediately with original equipment manufacturer's (O.E.M.) parts only, listed in this manual. "Use of parts which do not meet the original equipment specifications may lead to improper performance and compromise safety!"
- Do not change the engine's governor setting or over-speed the engine. The governor controls the maximum safe operating speed of the engine.
- Check fuel line, tank, cap, and fittings frequently for cracks or leaks. Replace if necessary.
- Do not crank engine with spark plug removed.
- Maintain or replace safety and instruction labels, as necessary.
- Observe proper disposal laws and regulations. Improper disposal of fluids and materials can harm the environment.

Do not modify engine.

- To avoid serious injury or death, do not modify engine in any way. Tampering with the governor setting can lead to a runaway engine and cause it to operate at unsafe speeds. Never tamper with factory setting of engine governor.



**WARNING:** This machine is equipped with an internal combustion engine and should not be used on or near any unimproved forest-covered, brush covered or grass-covered land unless the engine's exhaust system is equipped with a spark arrestor meeting applicable local or state laws (if any).

# Pre-Assembly

## PLANNING ASSEMBLY

Place box on a level surface. Remove all items from box. Make sure all items listed on the package contents list are included and not damaged.

## TOOLS REQUIRED



Safety goggles



Adjustable wrench

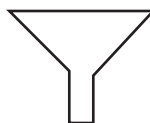

Funnel

## HARDWARE INCLUDED

 NOTE: Hardware not shown to actual size.



| Part | Description | Quantity |
|------|-------------|----------|
| AA   | Bolt M8x16  | 6        |
| BB   | Nut M8      | 6        |
| CC   | M8 Washer   | 6        |
| DD   | Bolt M6x16  | 4        |
| EE   | Nut M6      | 4        |
| FF   | M5x20       | 1        |

| Part | Description          | Quantity |
|------|----------------------|----------|
| GG   | Bolt ST4 8x16        | 2        |
| HH   | 8x40 Wheel Lock Pins | 3        |
| II   | Cotter Pins          | 3        |
| JJ   | D Pin                | 4        |
| KK   | Cable Clip           | 2        |

## PACKAGE CONTENTS

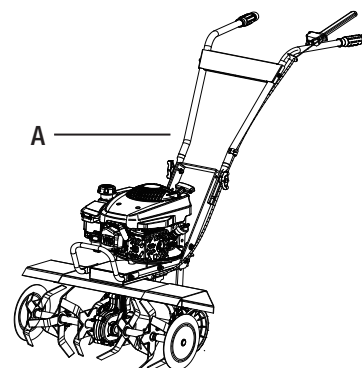
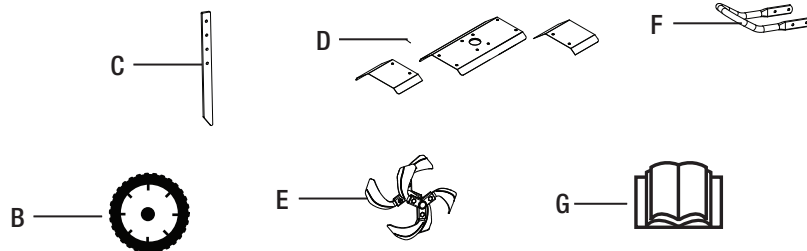

| Part | Description              | Quantity |
|------|--------------------------|----------|
| A    | Tiller Body/Upper Handle | 1        |
| B    | Wheel                    | 2        |
| C    | Depth Regulator          | 1        |
| D    | Tiller Protective Shield | 1        |

| Part | Description        | Quantity |
|------|--------------------|----------|
| E    | Tines              | 2        |
| F    | Bumper             | 1        |
| G    | Use And Care Guide | 1        |

# Assembly

## 1 Assembling the Rear Wheels

**NOTICE:** This tiller is shipped without gasoline or oil in the engine. Fill up the gasoline and oil BEFORE operating your machine.

- Pull the rear wheel downward so that the rear wheel can rotate freely, then lift the rear wheel bracket to the proper position. The rear wheel bracket will automatically attach with the spring. See Figure 1-1.

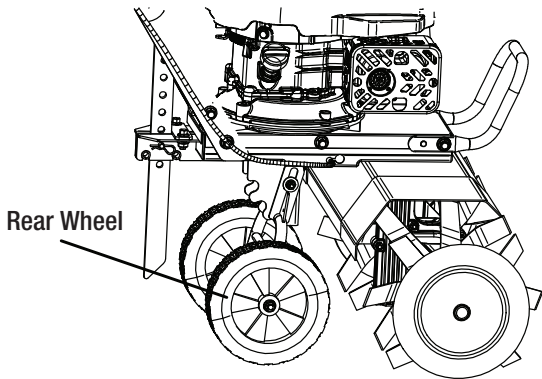

Figure 1-1

## 2 Assembling the Upper Handle

- Attach the upper handle to the lower bracket on the main body of the tiller. Properly align the holes and then secure with M8x45 bolt, washer, and plastic wing nut.

Align the face plate holes on the upper part of the handle. Insert a bolt and nut to secure. See Figure 1-2

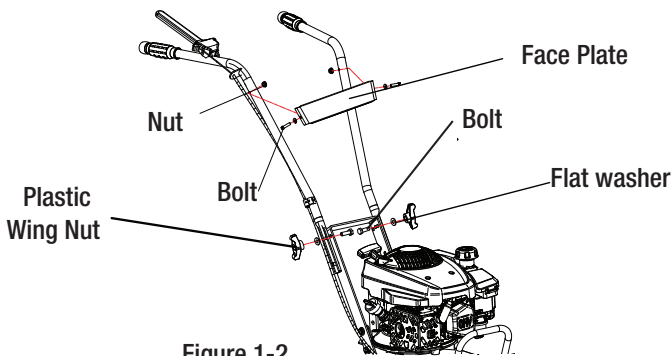

Figure 1-2.

## 3 Assembling the Depth Regulator

- First attach the depth regulator to the drag bar holder, choose proper height and then lock the depth regulator with a cleves pin. See Figure 1-3.

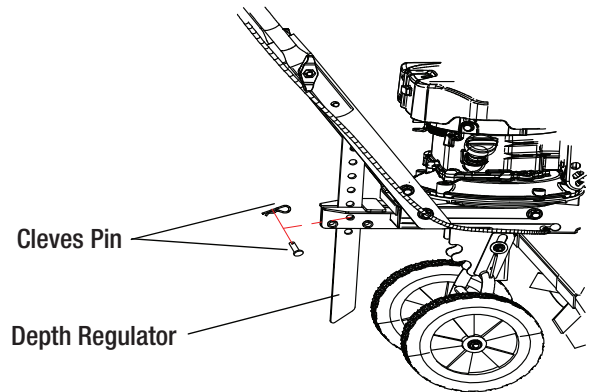

Figure 1-3

## 4 Assembling the Tines

- Insert the dust cover, tines, secondary tines, and disc to drive shaft in sequence and lock tines with D-Pin. See Figure 1-4

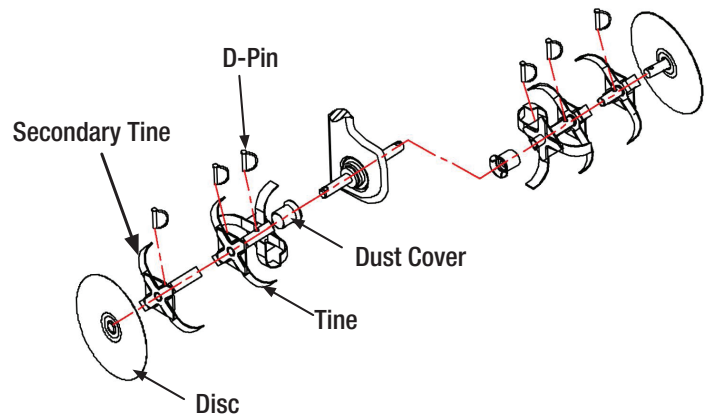

Figure 1-4

### 5 Assembling the Front Protective Shield

- Align holes on the protective shield end caps to the main protective shield and secure with M6x16 bolts and M6 nuts. See Figure 1-5

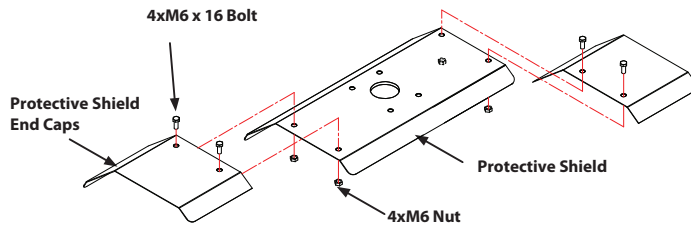

Figure 1-5



**WARNING:** Make sure the tiller protective shield is installed in place before starting the machine.



# Operation

## 1 Adding Gas and Oil



**WARNING:** Use extreme care when handling gasoline. Gasoline is extremely flammable and the vapors are explosive. Never fuel the machine indoors or while the engine is hot or running. Extinguish cigarettes, cigars, pipes and any other sources of ignition.

- Remove gas cap. Place funnel securely and add fuel. Do not top off.
- Secure the gas cap and wipe off any excess fuel. See Figure 1-6.

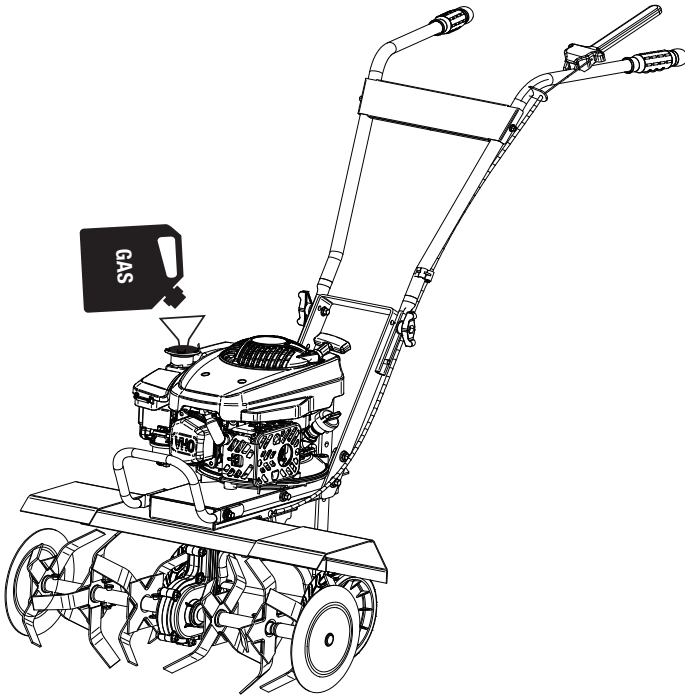
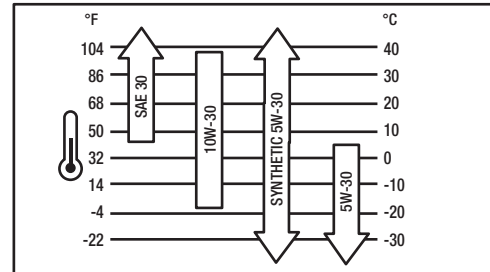

Figure 1-6



**IMPORTANT:** Use only Regular Octane Fuel.

- We recommend the use of 10W-30 oil. Other high-quality detergent oils are acceptable if classified for service SF, SG, SH, SJ or higher.
- Do not use special additives.
- Outdoor temperatures determine the proper oil viscosity for the engine. Use the chart to select the best viscosity for the outdoor temperature range expected.



- Place the tiller on a level surface.
- Remove the filler cap. Place the funnel securely and add oil. Do not top off. Check dipstick to confirm adequate amount of oil.
- Secure the oil cap and wipe off any excess oil. See Figure 1-9.

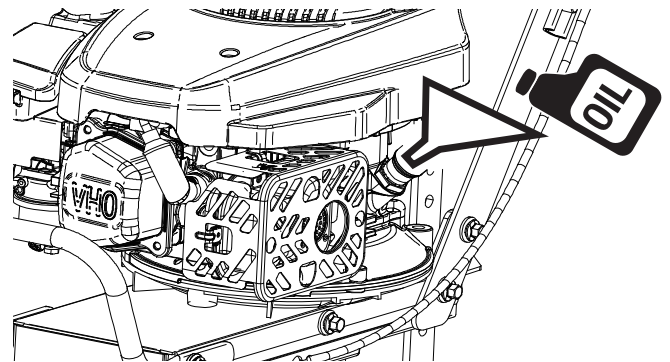

Figure 1-7



**IMPORTANT:** We recommend using 10W-30 Oil.

## Operation (continued)

# 2 Controls and Features

### RECOIL STARTER

- The recoil starter is attached to the right side of the upper handle. Stand behind the unit and pull the recoil starter rope to start the unit.

### PROTECTIVE SHIELD

- The tiller shield is located in the rear of the tiller and it is used to shield you from debris being thrown.

### FORWARD LEVER

- The forward lever located on the upper handle controls the tiller's action to start the self-propell and tine rotation.

### ON/OFF SWITCH

- The On/Off switch is needed to start and stop the tiller.

### DEPTH REGULATOR

- In hard compacted soil, it helps restrain the tiller's forward motion. In looser soil, it controls how deeply the tines can dig into the ground.

### TINES

- Tines are rotating metal blades that dig into the soil.

### OIL DIPSTICK

- Located on the engine is used to fill oil and measure oil. This tiller does not come with oil. Oil must be added before operating it.

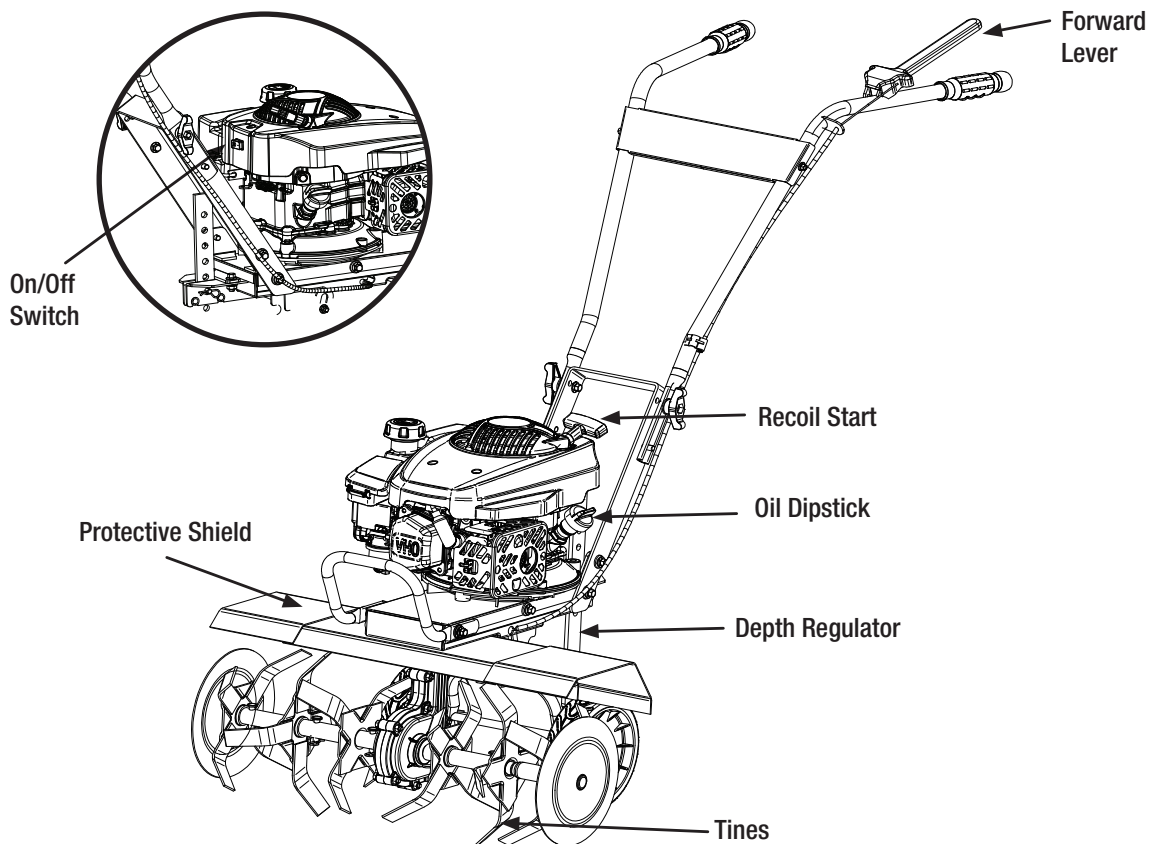

## Operation (continued)

### 3 Pre-Start Inspection

- Make sure all safety guards are in place and all nuts and bolts are secure.
- Check oil level in engine crankcase. Add oil if necessary.
- Check the fuel supply. Fill the fuel tank no closer than 1 inch from top of tank to provide space for expansion.
- Be sure the spark plug wire is attached and the spark plug is tightened securely.
- Check depth regulator lever position.
- Examine underneath and around engine for signs of oil or fuel leaks.
- Inspect fuel hoses for tightness and fuel seepage.
- Look for signs of engine damage.
- Remove excessive debris from muffler area and recoil starter.



**CAUTION:** Please do not start your tiller until you have read the manual that came with your tiller, and the sections in this manual tiller controls and safety. If you have read these, follow the steps below to start your tiller. Always perform this pre-start checklist before starting the engine.



**WARNING:** Gasoline is highly flammable and must be handled with care. Never fill the tank when the engine is hot or running. Always move outdoors to fill tank.

- Always set the wheels in tilling position before starting engine.
- Always put depth regulator lever in the transport position before starting engine. Tines should clear ground.



**DANGER:** Always keep hands and feet clear of rotating machine parts.

### 4 Starting the Tiller

#### COLD STARTS

- Put the engine switch located on the back of the engine on the (I) position.

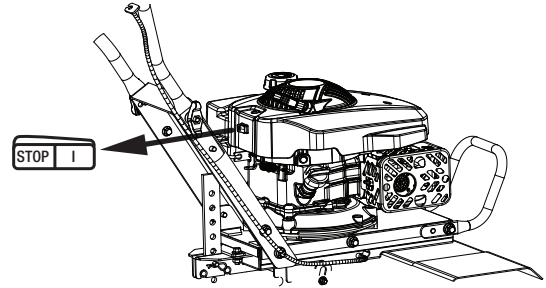

- Press the primer bulb 3 times.
- Pull the starter grip lightly until resistance is felt then pull rapidly.



**CAUTION:** Be sure the clutch is disengaged and the shift lever is in the neutral position to prevent sudden uncontrolled movement when the engine starts. The clutch is engaged by pulling in the clutch lever and disengaged by releasing the lever.

#### RESTARTING A WARM ENGINE

- Put the engine switch located on the back of the engine on the (I) position.
- Pull the starter grip lightly until resistance is felt then pull rapidly.

## Operation (continued)

### 5 Shutting Down the Tiller

- To stop the engine at any time, turn engine ON/OFF switch to the off position.

### 6 Tilling

- Adjust the depth regulator lever to desired tilling depth. Insert the clevis and cotter pin to secure depth regulator to desired depth. See Figure 1-8.

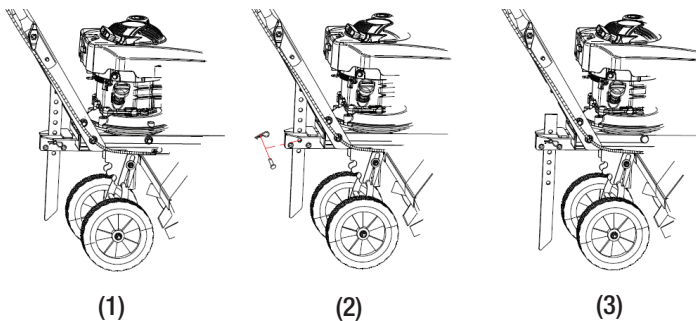

Figure 1-8



**WARNING:** Raise depth regulator up one hole at a time, testing tiller operation after each raise. Raising depth regulator too high can result in loss of control of tiller!

- Place the tiller in forward by pushing down on the drive safety control lever (FORWARD)--this will engage the wheels and tines.

**NOTICE:** You can slow the tiller's forward advance at any time by putting slight downward pressure on the handlebars. You can stop the tiller by releasing the drive safety control levers to the neutral position.



**WARNING:** Temperature of muffler and nearby areas may exceed 150°F. Avoid these areas. Do not move choke control to stop engine, backfire or engine damage may occur. To stop wheels and tines at any time, release drive safety control levers to neutral position. Always release drive safety control levers to neutral position AND STOP THE ENGINE before adjusting the depth of the regulator lever.

### 7 Drive Safety Control Levers

#### FORWARD LEVER

- Engages wheels and tines into forward.
- Pushing down the drive safety control lever (FORWARD) toward the handlebar engages the wheels and tines. Releasing the lever stops the wheels and tines and brings the tiller to a complete stop.

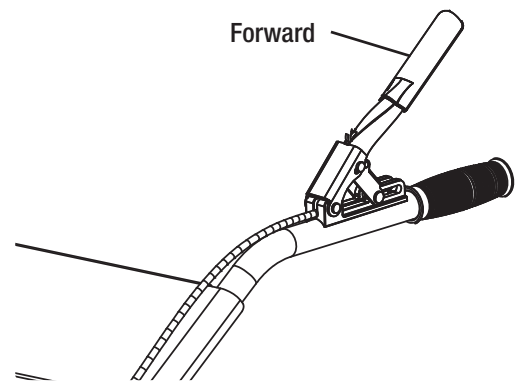

**IMPORTANT:** Practice operating the controls and tiller with tines out of ground before beginning to till. It is important that you know how to use the tiller properly, keep control at all times, stop the tines and wheels from turning, and stop the engine if necessary. If you do not know how to do these things, read the controls, adjustments and safety sections before proceeding.

### 8 Handle Height Adjustment

- To adjust the tiller height, loosen the plastic wing nut, select the appropriate hole for height and tighten. See Figure 1-8.

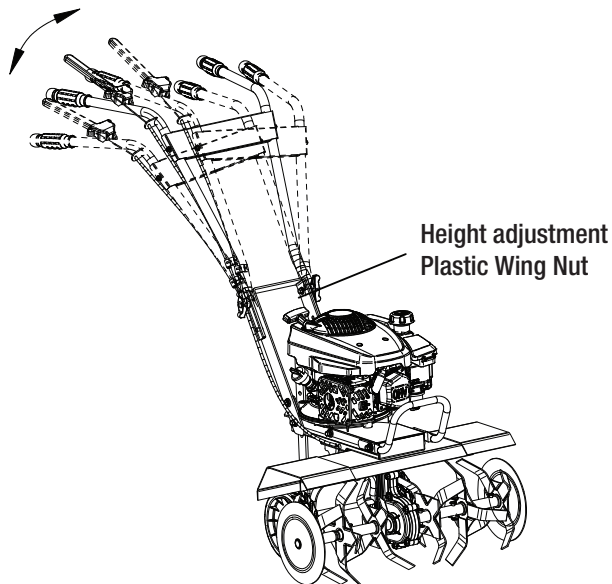

Figure 1-8.



**CAUTION:** Before adjusting the handle bar, place the tiller on firm level ground to prevent the handle from collapsing accidentally.

### 9 Tilling Tips

- The key to successful tilling is to begin with a shallow cut on the first pass, and then work an inch or two deeper on each successive pass.
- Tilling depth will vary with ground conditions.
- When beginning to till in unbroken ground or in extremely hard soil, set the clevis pin in the highest hole of the depth regulator. This will allow for shallow tilling. With the depth regulator in this position, make several light passes over the area to be tilled. Reset for deeper depths with successive passes.
- If tiller jumps or skids uncontrollably, lower the depth regulator by placing the clevis pin in a higher hole. This will allow for shallower tilling. Hold firmly to the handlebars to control sudden lurches.
- If weeds, tall grasses, vines, or other materials clog or jam the tines, reverse the tiller to unwind vegetation.
- Immediately release the drive control levers if the tines jam or you strike a foreign object. With the drive control levers in the neutral position, push throttle control to the stop position to stop the engine. Disengage the spark plug wire. When tines have stopped, remove foreign objects and check for damage.

### CULTIVATING

- Plant rows on 20" - 22" centers for ease of turning.
- Set the depth regulator lever with the detent pin in one of the higher holes. This will allow for shallow cultivation necessary to turn over weeds, and break up and aerate the soil.

# Maintenance

Always observe safety rules when performing any maintenance.

- The warranty on this tiller does not cover items that have been subjected to operator abuse or negligence. To receive full value from warranty, operator must maintain the string trimmer as instructed here.
- Changing of engine-governed speed will void engine warranty.
- All adjustments should be checked at least once each season.
- Periodically check all fasteners and make sure these are tight.
- Good maintenance is your responsibility, poor maintenance is an invitation to trouble.
- Follow good shop practices.
- Keep service area clean and dry.

- Use adequate light for the job at hand.

Make sure the engine is off before you begin any maintenance or repairs. This will eliminate several potential hazards.

- Be sure there is adequate ventilation whenever you operate the engine to avoid carbon monoxide poisoning.
- Never operate the engine in a closed building.
- Let the engine and exhaust system cool before touching.
- Do not run the engine unless instructed to do so.
- Read the instructions before you begin, and make sure you have the tools and skills required.
- To reduce the possibility of fire or explosion, be careful when working around gasoline.
- Use only a nonflammable solvent, not gasoline, to clean parts. Keep cigarettes, sparks and flames away from all fuel related parts.

- Lubricate the wheels at least once a season with light oil (or motor oil). If wheels are removed for any reason, lubricate surface of the axle bolt and inner surface of the wheel with light oil.
- Always use personal protection devices such as eye, hand and hearing protectors when performing any service or maintenance.
- Frequently check tiller tines. They should be free of nicks and cracks and securely fastened in place.
- Periodically tighten all bolts, nuts, screws, and check that all pins are properly installed to make certain the tiller is safe to operate.
- When completing maintenance or service, make sure all safety guards and devices are installed before using the tiller.
- Where replacement parts are necessary for periodic maintenance and servicing, use only new, original replacement parts or their equivalents for repair and replacement to restore your equipment to original specifications.
- The manufacturer and/or distributor will not be responsible for injuries or damages caused by use of unapproved parts and/or accessories.
- A first aid kit should be kept readily accessible while performing maintenance on this equipment.

# Maintenance (continued)

## MAINTENANCE SCHEDULE

- Your tiller has been designed and produced by the industry's leading manufacturer of outdoor power equipment to provide you with years of reliable operation. Keeping your tiller in top running condition will prolong its life, and help you obtain optimum performance.
- Please read this normal care schedule, and note the recommended care operating intervals to extend the life of your tiller.

| Maintenance Operation |              | Before Each Use                      | First Month or 20 Hours | Every 3 Months or 50 Hours | Every 6 Months or 100 Hours | Every Year or 300 Hours |
|-----------------------|--------------|--------------------------------------|-------------------------|----------------------------|-----------------------------|-------------------------|
| Belt Tension          | Adjust       |                                      | √                       |                            | √                           |                         |
| Engine Oil            | Check Level  | √                                    |                         |                            |                             |                         |
|                       | Change       |                                      | √                       |                            | √                           |                         |
| Air Filter            | Check        | √                                    |                         |                            |                             |                         |
|                       | Clean        |                                      |                         | √*                         | √*                          |                         |
|                       | Replace      |                                      |                         |                            |                             | √                       |
| Tine Shaft            | Clean        | √                                    |                         |                            |                             |                         |
| Wheel Axle Shaft      | Lubricate    |                                      |                         | √                          |                             |                         |
| Spark Plug            | Clean Adjust |                                      |                         |                            | √                           |                         |
| Fuel Strainer         | Clean        |                                      |                         |                            | √                           |                         |
| Fuel Line             | Check        | Every 2 Years (Replace if necessary) |                         |                            |                             |                         |

\*Service more frequently when used in dusty areas.



**WARNING:** Use only genuine replacement parts. Other parts may damage the tiller or result in injury.

## Maintenance (continued)

### CHECK OR FILL ENGINE CRANKCASE

- Add oil. Do not overfill. Use a clean, high quality detergent oil. Do not mix oil with gasoline. Oil level must be full.
- Check the oil level by removing oil fill plug. Oil level should be up to the bottom of the fill plug opening.
- Always check oil level before starting engine.



**IMPORTANT:** Engine is shipped from factory without oil. You must add engine oil before starting engine.

### CHECK THE TILLER TRANSMISSION OIL

- Check the oil level annually. To check the oil level please do the following.
- Move tiller to level ground.
- Remove oil level dipstick located between the handlebar mounts on the engine mount.
- If the oil level is low according to the dipstick, add oil.
- Replace oil level dipstick in the filler hole.



**IMPORTANT:** The tiller transmission is shipped from the factory with the proper amount of oil. Check the oil level annually.

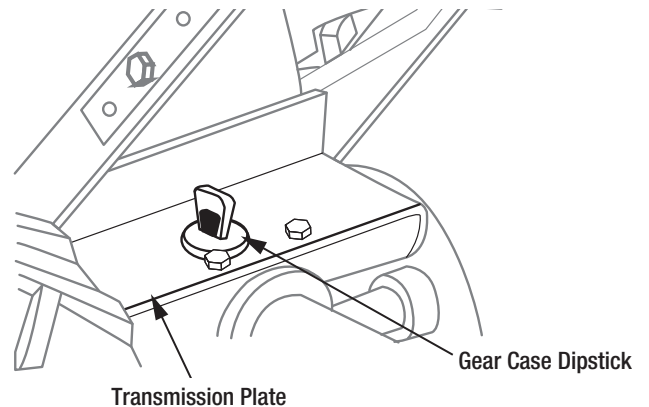

### LUBRICATION

- Proper lubrication of moving mechanical parts is critical for proper care and maintenance. Oil the moving parts shown at 10 hour intervals using a 30 weight oil.

### CLEAN TINE AXLE SHAFT

- Turn off engine. Engine must be cool.
- Remove spark plug wire and secure from spark plug.
- Tip the tiller forward. Block the tiller in position so that it rests on the engine mount and the tines are exposed.
- Remove all vegetation, string, wire, and other material that may have accumulated on the axle between the inside set of tines and the seal on the transmission housing.
- Tip the tiller back to a level position.
- Replace spark plug wire.



## Care, Cleaning and Storage

Follow the steps below to prepare your tiller for storage.

- Protect wheels and axles from rust by removing the lockpin and sliding the wheel off the hub.
- Coat the axles lightly with axle grease.
- Slide wheel back on hub and insert lock pin.
- Drain fuel system completely or add fuel stabilizer to prevent fuel from gumming up during extended storage period.
- While engine is still warm, drain the oil from the engine. Refill with fresh oil of the recommended grade.
- Clean external surfaces, engine and cooling fan.
- Remove spark plug, pour one ounce of SAE 30 oil into spark plug hole.
- Plug hole and pull starter cord slowly to distribute oil evenly in cylinder head area.
- Reinstall spark plug.
- Transport unit to a suitable storage location. If you have chosen to use a fuel stabilizer and have not drained the fuel system, follow all safety instructions storage precautions in this manual to prevent the possibility of fire from the ignition of gasoline fumes. Remember, gasoline fumes can travel to distant sources of ignition and ignite, causing risk of explosion and fire.
- If there is any possibility of unauthorized use or tampering, remove the spark plug and store it in a safe place before storing the rototiller unit.
- Be sure to plug the spark plug hole to prevent foreign material from entering.



**WARNING:** Do not store tiller in an unventilated area where fuel fumes may reach flame, sparks, pilot lights or an ignited object. Drain fuel outdoors away from any ignition sources. Use only approved fuel containers.

# Troubleshooting

| Problem  | Cause  | Solution   |
|--|--|--|
| The engine is difficult to start.  | <ul style="list-style-type: none"> <li><input type="checkbox"/> Out of fuel.</li> <li><input type="checkbox"/> The engine switch is Off.</li> <li><input type="checkbox"/> The engine is not primed.</li> <li><input type="checkbox"/> The spark plug wire is disconnected.</li> <li><input type="checkbox"/> The spark plug is fouled.</li> <li><input type="checkbox"/> The carburetor is dirty.</li> <br/> <li><input type="checkbox"/> The air filter is clogged.</li> <li><input type="checkbox"/> The fuel is contaminated.</li> </ul> | <ul style="list-style-type: none"> <li><input type="checkbox"/> Add fresh fuel.</li> <li><input type="checkbox"/> Turn the engine switch on.</li> <li><input type="checkbox"/> Move the choke lever to the ON position.</li> <li><input type="checkbox"/> Attach spark plug wire to the spark plug.</li> <li><input type="checkbox"/> Remove spark plug and inspect. Replace if necessary.</li> <li><input type="checkbox"/> Take the tiller to an authorized service center to clean the carburetor.</li> <li><input type="checkbox"/> Remove and clean the air filter.</li> <li><input type="checkbox"/> Drain and clean the fuel tank. Fill with fresh fuel.</li> </ul> |
| <b>Engine Problems</b><br>The engine smokes excessively, runs very "rough," runs erratically, or cannot maintain full speed. | <ul style="list-style-type: none"> <li><input type="checkbox"/> No Engine Oil.</li> <li><input type="checkbox"/> Engine oil is not at proper level.</li> <li><input type="checkbox"/> The spark plug is fouled.</li> <li><input type="checkbox"/> The air filter is clogged.</li> <li><input type="checkbox"/> The fuel is contaminated.</li> <li><input type="checkbox"/> The carburetor is out of adjustment.</li> </ul>   | <ul style="list-style-type: none"> <li><input type="checkbox"/> Add engine oil.</li> <li><input type="checkbox"/> Check engine oil, add or drain engine oil if necessary. Remove spark plug, inspect or replace if necessary.</li> <li><input type="checkbox"/> Remove and clean air filter.</li> <li><input type="checkbox"/> Drain and clean the fuel tank. Fill with fresh fuel.</li> <li><input type="checkbox"/> Take the tiller to an authorized service center to clean the carburetor.</li> </ul>  |
| Excessive vibration and noise.   | <ul style="list-style-type: none"> <li><input type="checkbox"/> Loose parts.</li> <li><input type="checkbox"/> Engine problems (above).</li> <li><input type="checkbox"/> Abnormal noise or squeal coming from belt drive.</li> </ul>  | <ul style="list-style-type: none"> <li><input type="checkbox"/> Tighten all fasteners.</li> <li><input type="checkbox"/> Refer to engine solutions (above).</li> <li><input type="checkbox"/> Normally due to belt/pulley break in period. Refer to belt tension adjustment section.</li> </ul>  |
| Tines will not rotate.   | <ul style="list-style-type: none"> <li><input type="checkbox"/> Debris interfering with the tines.</li> <li><input type="checkbox"/> Tines are loose.</li> <li><input type="checkbox"/> Improper drive cable adjustment.</li> <li><input type="checkbox"/> Damaged drive belts.</li> </ul>   | <ul style="list-style-type: none"> <li><input type="checkbox"/> Remove debris from around tines.</li> <li><input type="checkbox"/> Replace tine bolts and nuts.</li> <li><input type="checkbox"/> Refer to "Belt Tension Adjustment" section to decrease belt tension.</li> <li><input type="checkbox"/> Replace drive belts.</li> </ul>   |
| Tines continue to rotate when drive lever is not engaged.  | <ul style="list-style-type: none"> <li><input type="checkbox"/> Improper drive cable adjustment.</li> <li><input type="checkbox"/> Damaged drive belts.</li> </ul>   | <ul style="list-style-type: none"> <li><input type="checkbox"/> Refer to "Belt Tension Adjustment" Section to decrease belt tension.</li> <li><input type="checkbox"/> Replace drive belts.</li> </ul>   |
| Engine will not stop.  | <ul style="list-style-type: none"> <li><input type="checkbox"/> Check the switch.</li> </ul>   | <ul style="list-style-type: none"> <li><input type="checkbox"/> Replace the switch.</li> </ul>   |
| Tines will not cut properly.   | <ul style="list-style-type: none"> <li><input type="checkbox"/> The tines assembled incorrectly.</li> </ul>  | <ul style="list-style-type: none"> <li><input type="checkbox"/> Refer to "Install the Tines" Section.</li> </ul>   |
| Frequent engine stalling.  | <ul style="list-style-type: none"> <li><input type="checkbox"/> Excessive tilling speed / depth.</li> <li><input type="checkbox"/> Engine problems (above).</li> </ul>   | <ul style="list-style-type: none"> <li><input type="checkbox"/> Till at a moderate pace. Make multiple passes.</li> <li><input type="checkbox"/> Refer to engine solutions (above).</li> </ul>   |

# Service Parts

| Part | Description  | Quantity |
|------|--------------|----------|
| AA   | Drive Pulley | 1        |
| BB   | Wheel        | 2        |
| CC   | Forward Belt | 1        |

| Part | Description      | Quantity |
|------|------------------|----------|
| DD   | Air cleaner Assy | 1        |
| EE   | Recoil           | 1        |
| FF   | Tines            | 4        |

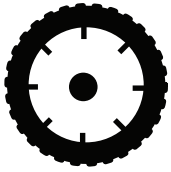

Wheel

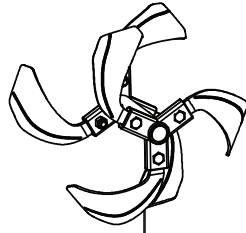

Tine

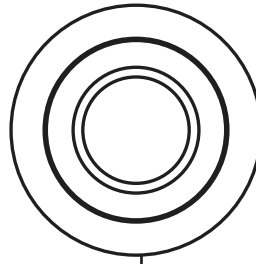

Driven Pulley

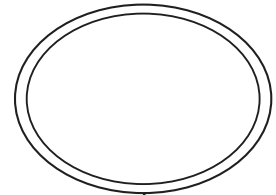

Forward Belt

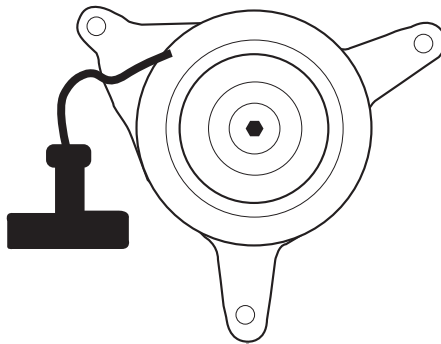

Recoil

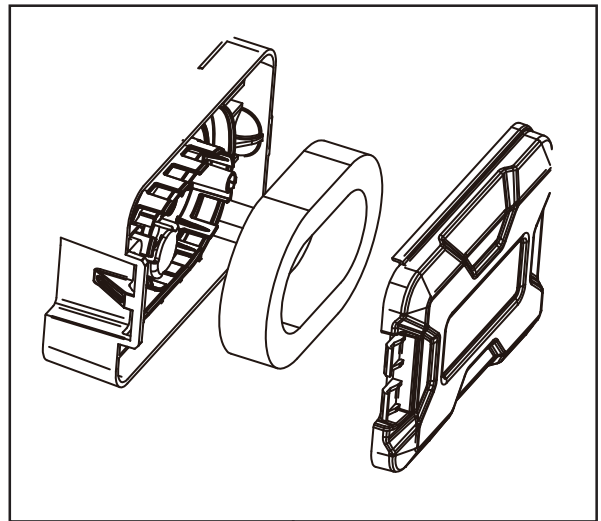

Air Filter Assembly