

# iSpring Water Systems

WDS SERIES USER MANUAL Ver.05/2020



 **Filter.com**

iSpring Water Systems, LLC (since 2005)

Copyright ©2005-2020 ISPRING WATER SYSTEMS, LLC. All rights reserved.

## Table of Contents

<b>Product Operation and Specifications .....</b>	<b>3</b>
<b>Component List .....</b>	<b>3</b>
<b>Tools Required.....</b>	<b>3</b>
<b>Parts Required (Not Included) .....</b>	<b>4</b>
<b>Installation Overview .....</b>	<b>4</b>
<b>Pre-installation Notes .....</b>	<b>5</b>
<b>Pre-installation.....</b>	<b>5</b>
<b>Installation.....</b>	<b>5</b>
<b>Maintenance Instructions.....</b>	<b>8</b>
<b>Filter Change Instructions.....</b>	<b>8</b>
<b>Troubleshooting .....</b>	<b>9</b>
<b>Warranty .....</b>	<b>10</b>
<b>Warranty Registration Form.....</b>	<b>11</b>

## Product Operation and Specifications

<b>Model</b>	<b>WDS Series</b>
<b>Flow Rate</b>	15 GPM
<b>Minimum Working Pressure</b>	25 psi
<b>Maximum Working Pressure</b>	80 psi
<b>Operating Temperatures</b>	60-90 °F
<b>pH Range</b>	6- 9

## Component List

<b>Part</b>	<b>Description</b>	<b>Qty</b>
<b>System bracket with caps</b>	Metal bracket with 1" NPT inlet /outlet Black caps	1
<b>Housing</b>	Housing Model # WDS150K(HB28B)or Model # WDS80K(HB18B)	1
<b>Cartridges</b>	Anti-scale polyphosphate filter Model # FWDS150Kor Model # FWDS80K	1
<b>Wrench</b>	Housing wrench Model # AWR3	1

## Tools Required

Safety glasses	Hacksaw
Towels	Soldering iron or torch
Flat head screwdriver	Adjustable wrench
Medium Crescent wrench	Teflon tape

## Parts Required (Not Included)

- (2x) Shutoff valves
- (2x) Hex nipples or pipe nipples
- (2x) Pipe union pressure regulators (as needed)
- (1x) Ground jumper cable

## Installation Overview

WDS80K

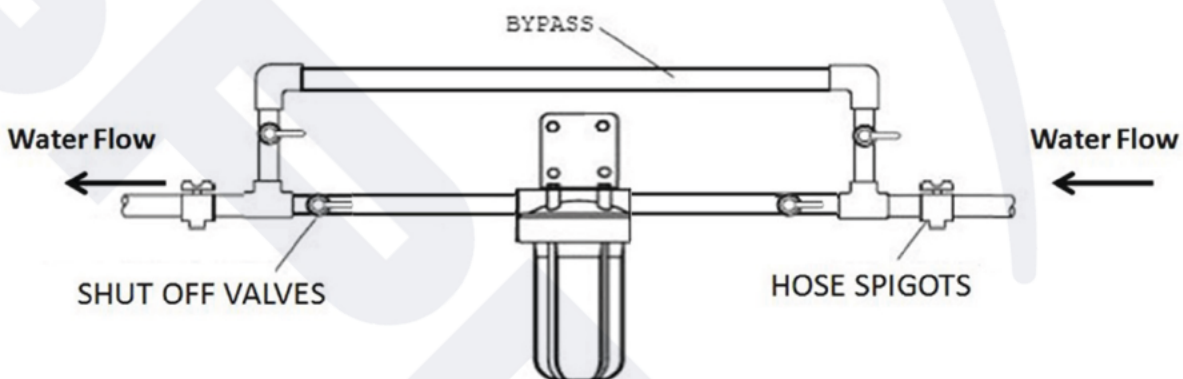

WDS150K

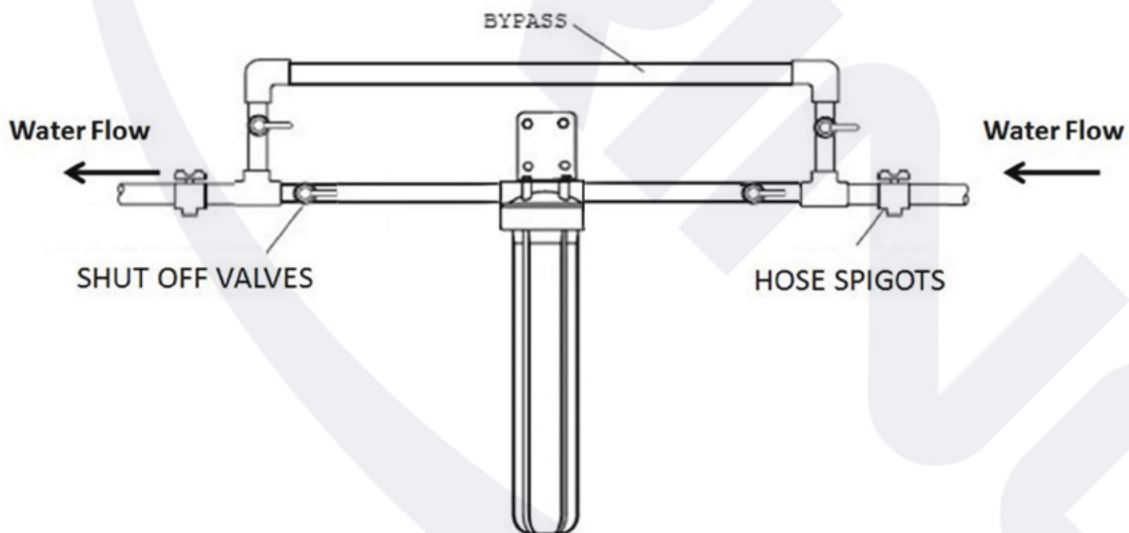

## Pre-installation Notes

- This installation guide provides a step-by-step, start to finish procedure for installing your iSpring whole house water filter. All steps provided herein are for typical installations only. Your specific application may vary.
- This filter system should not be used with water that is microbiologically unsafe or of unknown quality without adequate disinfection before and/or after the system.
- The filter should be kept in a sheltered location and should never be exposed to freezing or extreme temperatures and direct sunlight, such damage is not covered under any warranty.
- Be sure to note the inlet/ outlet markings and the water flow direction.
- A three-valve bypass valve and loop may be installed to loop the entire system to make servicing easier.
- Hard copper pipes generally come in two types. Use the thicker "L" type copper pipe rather than thinner "M" type copper pipe.
- Follow all local plumbing and building codes.

## Pre-installation

- Turn off the water to your house before beginning the installation.
- Turn off power to your water heater before installation.
- Open all plumbing fixtures in the house to drain the lines of water and pressure.
- Lay out all the fittings and tools you will need to install the system depending on your configuration.
- Be sure to use Teflon tape on threaded fittings.

## Installation

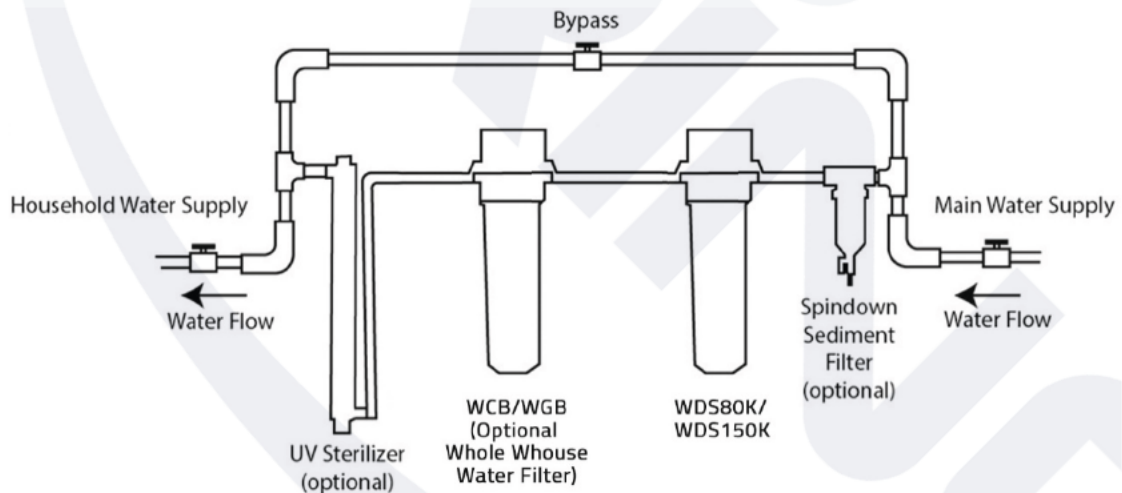

- The filter should be placed on the main water supply line near where it enters the house at any point past the main shutoff valve for the whole house, but before pipes branch off into multiple directions. However, you may choose to locate the filter after the line branches to the inside and outside plumbing depending on your filtration intent. **Your filters should be located in a dry, level area and protected from freezing temperatures and direct sunlight.**

**Notice:**

*The filter housing comes with a 1" NPT Male inlet/outlet and will require additional fitting to adapt to your plumbing. A shutoff valve is recommended prior to the system.*

**Step 1 - Measure the System and Cut the Pipe**

- Determine location and water flow direction for the system.

**Notice:**

*If the water flow of the pre-installed caps union points conversely to your water flow, you can converse the caps union by unscrewing the bolts that connect it with the bracket.*

- Measure, cut, and remove the section of water line where the system is to be installed. When determining the length of pipe to cut, account for filter width, shutoff valves, union fittings, nipple fittings, pressure gauges (if used) and bypass valve (if used).
- Allow the cut line to drain. Smooth the newly cut ends down to avoid jagged points or edges.

**Step 2 - Mount the Filter Bracket**

- Securely mount the whole house filter bracket and ensure the system is level.
- Attach your plumbing to the INLET and OUTLET with 1" male threaded adapter (not included).

**Step 3 - Add on Shutoff Valve and Pressure Gauge (Optional)**

- Place a shutoff valve and/or a pressure gauge on either side of the filter for ease of monitoring and ease of service.

- 1) You may need to adjust pipe length or distance. Fit a pipe union onto the cut section of the main water line.
- 2) Fit together pipe union and shutoff valve. Use Teflon tape on threaded fittings.
- 3) Simultaneously fit together shutoff valve and whole house filter using pipe nipple or hex nipple to draw them together on the FEED side of the filter.
- 4) Simultaneously fit together filter and the shutoff valve on the OUTLET side of the filter. Fit pipe union to shutoff valve on OUTLET side.
- 5) Check pipe length and pipe union length to see if additional pipe length or union is required. Join pipe union and pipe.
- 6) Fit pipe hanger on water INLET and OUTLET side for additional support.

**Step 4**

- Connect ground jumper wire (if necessary).

**Step 5- Filter Cartridges and Housings Assembly**

- Unwrap cartridges and insert each into each of the housing centering on the standpipe.
- Hand tighten the Blue Filter Housing. Then, using the supplied Filter Wrench, lightly snug the housing while making sure not to over-tighten.

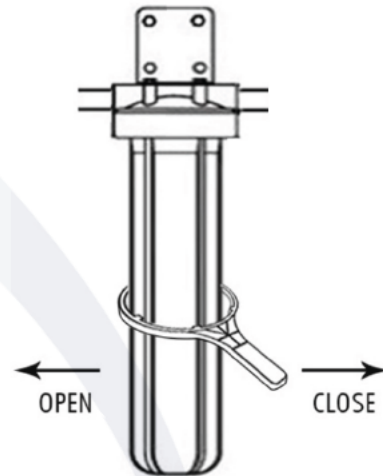
**Step 6 - Turn on water and flush system**

- Slowly turn on water main to fill the housing. After a few minutes, the sound of water entering the system will stop.
- Check for leaks.
- Open the nearest COLD water faucet and run water for about 10 minutes.

**CAUTION:**

*Do not use a hot water faucet to perform the initial system flush.*

**NOTICE:**

*Continue to run water until it runs clear and all air has been purged. Shut the water off and let the unit sit for a while, and then flush again. It is not unusual for the water to appear "cloudy" for a day or so following installation. This cloudiness is actually tiny air bubbles being purged from the filters. This is normal and will clear up in a day or two.*

**NOTICE:**

*After prolonged periods of nonuse (such as a vacation), it is recommended that the system be flushed thoroughly for at least 10 minutes before using the water.*

**Step 7 - Turn off the faucet and your system is ready for use.****NOTICE:**

*Even though there is filtered water in the cold water lines, the hot water heater is still full of raw water. Through normal use, this water will be replaced with filtered water in about 2 or 3 days.*

## Maintenance Instructions

Your iSpring Whole House Water System requires care and cleaning after a period of time. It is recommended that the cartridges be replaced every 6-12 months depending on the amount of contaminants present in the water supply. If the system has been working properly and the pressure is slowing, it may be time to change the filter cartridge.

Replacement cartridges and parts can be ordered online at [www.123filter.com](http://www.123filter.com) or by calling 678-261-7611.

## Filter Change Instructions

### Part 1- Remove the old cartridge

1.1 Turn off the water supply to the system. Open a nearby faucet to release the pressure and drain the water.

Depress the pressure release button on the top of the filter housing to relieve system pressure. This will make removing the filter housing easier.

1.2 Unscrew the housing using the filter wrench included (AWR3) with your system, or a commercially available “strap” type wrench.

1.3 Locate and remove the large O-ring using a small, clean flat head screwdriver. Try not to remove any of the lubricant. Set it aside in a clean, safe place.

1.4 Remove and discard the old filter cartridge.

### Part 2- Clean the housings

2.1 Scrub the housing and cap with warm water mixed with about 2 tablespoons of household bleach using a sponge or soft rag. Wear rubber gloves. **Rinse all parts very thoroughly!**

2.2 Lubricate the O-ring with clean silicone grease if needed. **DO NOT USE PETROLEUM JELLY.** Insert the O-ring in filter groove and press into place. **Make sure the O-ring is seated correctly.**



#### CAUTION:

*This step is important to ensure the proper filter seal. Make sure the O-rings (ORB) are seated level in the groove. If the O-ring appears damaged, stretched, or crimped, it should be replaced.*

### Part 3- Install the New Cartridge

3.1 Remove the new filter packaging and insert the filter cartridges into the housings, making sure they slip over the standpipe in the bottom of the housing.

3.2 Align the bottom of the housing into the cap and hand tighten, then use the filter wrench (AWR3) to fit it snugly. **Do not over-tighten.**

3.3 Close any open valves. Turn on the water supply slowly to allow the system to fill with water. **Inspect carefully for leaks.** If a leak is found, remove the housing and inspect the O-ring to ensure that it is seated properly, and then retighten.

#### Part 4- Flush the System

4.1 Flush the system by turning on a few cold-water faucets. Allow the water to run until the air has been purged. New filter cartridges may contain air bubbles after installation. Water may be cloudy initially as the filters and system clear of trapped air.

### Troubleshooting

Problem	Solution
Water Pressure is slowing after a period of time	It is recommended that the cartridges be replaced every 6-12 months depending on the amount of contaminants present in the water supply. If the system has been working properly and the pressure is slowing, it may be time to change the filter cartridge.
Water Pressure is slowing immediately after installation	1) The cartridges may be installed incorrectly. Check to see if a piece of the plastic wrapping is still protecting the filter cartridges.
Water appears cloudy and grey	Water may appear cloudy or grey for the first 3-5 days after installation and will turn back to normal once the initial flushing is completed.
Leaking from the housing connection	The O-ring may not be in place. If it still leaks after adjusting the O-ring, please contact iSpring Customer Service at 678-261-7611 or email us at <a href="mailto:support@ispringfilter.com">support@ispringfilter.com</a>
Leaking from the pressure release button	The pressure release button has a screw under the bracket. Simply tighten that screw and the leaking should stop.

## Warranty

Visit [www.123filter.com](http://www.123filter.com) to complete the warranty registration form online.

### iSpring Limited Lifetime Warranty

This Limited Warranty extends to the original purchaser of the system only. This warranty only covers all Manufacturer-supplied items that prove to be defective in material, workmanship, or factory preparation. This warranty covers parts only; all labor is excluded from this warranty, including, but not limited to, services related to the removal, replacement, installation, adjustment, maintenance, and/or repair of the unit or its component items. This warranty applies only for the first full calendar year from date of purchase. The following items are excluded from this warranty: Filter Cartridges, and the O-rings that require regular replacement as a result of ordinary usage.

No warranty is made with respect to defects or damages due to neglect, misuse, alterations, accident, misapplication, physical damage, or damage caused by fire, acts of God, or freezing. These warranties apply only to the original registered owner so long as the owner owns the home in which the unit was originally installed. **Customer must register their system with iSpring within 90 days of purchase\* in order to obtain a warranty.** Warranty will discontinue after the unit is removed from the location where it was originally installed. Warranty begins on the date of delivery of product to the customer. Improper maintenance of system (i.e. not replacing filters or media) on time will be considered "neglect". Installation of any system on water conditions outside of or beyond the recommended specs of any system voids any warranty.

Disclaimers: This Limited Warranty applies only if the system is installed, used, and maintained in compliance with all instructions and requirements enclosed with the system. This warranty will be void for failure to observe the following conditions:

1. The system is to be used with potable water supply only.
2. Feed water pressure to the unit is no less than 25 PSI and no greater than 80 PSI.
3. Feed water temperature to the unit must be no less than 40°F and no more than 100°F.
4. Feed water must have a pH between 6 and 11.

While the testing was performed under standard laboratory conditions, actual performance may vary. The Manufacturer does not know the characteristics of your water supply. The quality of water supplies may vary seasonally, or over a period of time. Your water usage may vary as well. The Manufacturer assumes no liability for the determination of the proper equipment necessary to meet your requirements, and we do not authorize others to assume such obligation on our behalf.

This Limited Warranty does not cover any Manufacturer-supplied items that are defective as a result of the use of improper parts, equipment or materials. This warranty does not cover alterations or modifications of the unit or failure of a unit caused by such alterations and modifications.

Incidental and Consequential Damages Limitation: The Manufacturer will not be responsible for any incidental or consequential damages as a result of the failure of this unit to comply with express or implied warranties or any defect in the unit, including but not limited to, lost time, inconvenience, damage to personal property, loss of revenue, commercial losses, postage, travel, telephone expenditures, or other losses of this nature. In case some states do not allow the exclusion or limitation of incidental or consequential damages, you may choose to return the system. If you choose to keep it, you understand this exclusion WILL STILL apply to you.

Owner's Warranty Responsibilities: As a condition of this Limited Warranty, the owner must ensure that periodic maintenance of the system is performed as described in the literature enclosed with the system. Neglect, improper maintenance, abuse, modification, or alteration of the unit will invalidate this Warranty. Should your unit develop a defect or otherwise fail to perform in accordance with this warranty, you should contact the retailer from whom the product was originally purchased.

Implied Warranties: The implied at-law warranties of merchantability and fitness for a particular purpose shall terminate on the date one year after the date of purchase.

To register your product for the warranty, visit our website [123filter.com](http://123filter.com) and go to the **"Warranty Registration"** tab. If you have any questions or concerns about your product, please do not hesitate to call or email us, or put it in the notes/comments upon your warranty registration. Your satisfaction is our business!

## Warranty Registration Form

Name \_\_\_\_\_ Order# \_\_\_\_\_

Email \_\_\_\_\_ Phone \_\_\_\_\_

Address \_\_\_\_\_

City \_\_\_\_\_ State \_\_\_\_\_ Zip Code \_\_\_\_\_

Model#/ Serial Number \_\_\_\_\_

**Send to:**

iSpring Water Systems, LLC  
2480 Industrial Park Blvd  
Cumming, GA 30041  
678-261-7611

**Plumber's information (Optional)**

We like to recommend good plumbers throughout the USA and if you are happy with your installer, please give us their information so that we can pass it on as a courtesy. Thank you for your time.

Name of plumbing company used to install the system: \_\_\_\_\_

Phone #: (\_\_\_\_\_) - \_\_\_\_\_ of the plumbing installer.



**iSpring Water Systems, L.L.C.**

**2480 Industrial Park Blvd**

**Cumming, GA 30041**

**(678)261-7611**

**M-F 8:30-5:30 EST**

**[sales@ispringfilter.com](mailto:sales@ispringfilter.com)**