

OWNER'S MANUAL

RGC2

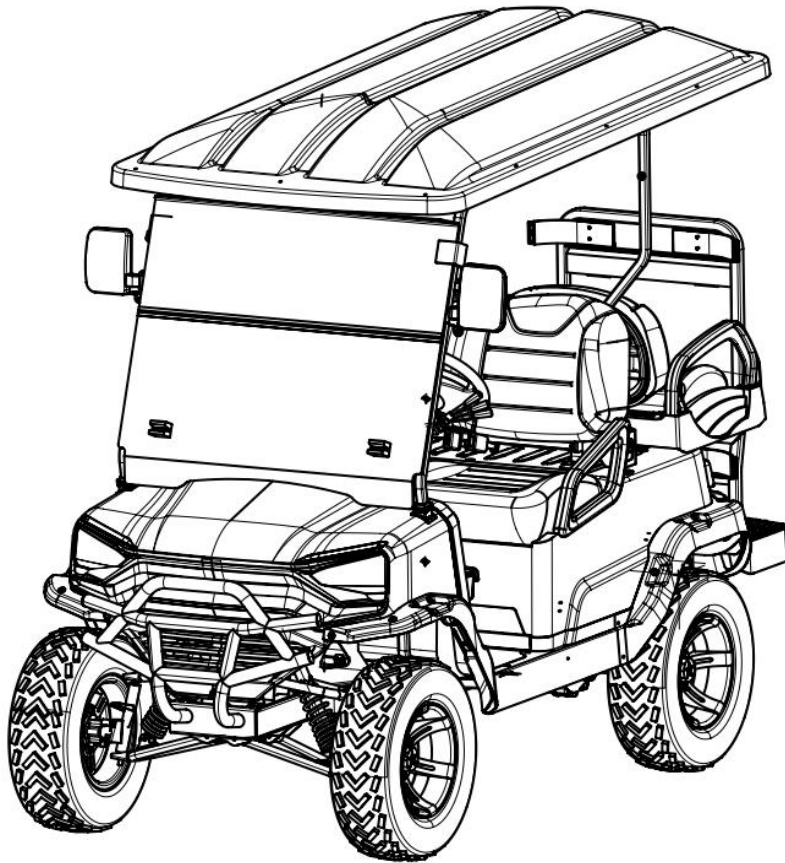

Table of Contents

Section 1	Introduction	1
Section 2	Purpose of use.....	1
Section 2	Safety warnings.....	1-2
Section 4	Safety Labels.....	3-6
Section 5	Technical specification.....	7
Section 6	Parts.....	8-10
Section 7	Control and functions.....	11-21
Section 8	Safe driving	22-25
Section 9	Operation warning.....	26-27
Section 10	Steering system maintenance and adjustment..	28
Section 11	Battery	29-31
Section 12	Toe in of front wheels.....	32-33
Section 13	Tire repair and maintenance.....	34-36
Section 14	Use and maintenance of motor controller..	37-45
Section 15	Trouble shooting.....	46-48
Section 16	Fault information.....	49-51
Section 17	Lithium Battery Warranty.....	52
Section 18	Manufacture Warranty.....	53-54

Section 1-3 Introduction, Purpose of Use, Safety Warnings

Introduction

Dear Customer,

Thank you for purchasing this Champion Motorsports Group product. The proper use and maintenance of the product are outlined in this instruction manual. Following these instructions will ensure your long-term safe and worry-free use of the vehicle.

Purpose of Use

The vehicle is designed to be used on flat, smooth, barrier-free roads. It can be used for country road driving. An adult is required to drive the vehicle. The vehicle should not be used on rough terrain.

The vehicle is equipped with an AC motor rated at 5KW. The speed is changed by the voltage applied to the electronic gas pedal. The vehicle is equipped with a rear brake drum to brake the vehicle, which is controlled by a brake pedal located on the left side.

Safety Warnings

The following symbols appear throughout this manual and on vehicle labels. Your safety is involved when these symbols are used; become familiar with their meanings before reading the manual.

DANGER indicates an imminently hazardous situation which, if not avoided, will result in death or serious injury. This signal word is to be limited to the most extreme situations.



WARNING indicates a potentially hazardous situation which, if not avoided, could result in death or serious injury



CAUTION indicates a potentially hazardous situation which, if not avoided, may result in minor or moderate injury. It may also be used to alert against unsafe practices.



NOTICE indicates a potentially hazardous situation which, if not avoided, could result in property damage.



Section 1-3 Introduction, Purpose of Use, Safety Warnings cont'd

This manual contains important safety information and instructions that must be read carefully before using the vehicle. For your own safety and the safety of others, please follow these rules.

- Unsafe and careless use of the vehicle can lead to serious personal injury. Drivers can minimize potential hazards by wearing safety belts. Drivers and passengers should fasten their seat belts before driving. Avoid rough roads and obstacles. Always keep both hands on the wheel when driving.
- It is not recommended to drive this product on the road surface with a slope greater than 30 degrees.
- Children under the age of 16 are not suitable for driving this product.



Failure to comply with the warnings in this manual can result in severe injury or death.



Read this entire manual carefully before operating this vehicle. Do not attempt to operate this vehicle until you have thorough knowledge of the controls and features.



Regular inspections and maintenance, along with good operating techniques, will help ensure your safe enjoyment of the capabilities and reliability of this vehicle.

The manufacturer maintains the right to change the design of the vehicle without responsibility to make the changes to units purchased before changes were made. The information in this manual can change without notice.

All information in this owner's manual is based on the latest product information at the time of publication. Due to constant improvements in the design and quality of production components, some discrepancies may be found between your vehicle and the information presented in this publication. The content in this publication is intended for reference use only. The manufacturer is not liable for omissions or inaccuracies. Any reprinting or reuse of the content in this publication, whether whole or in part, is expressly prohibited.

Section 4 Safety Labels

Safety and warning labels are on the vehicle for your protection. Read carefully and comply with the instructions on the labels. If any label shown in this manual is different from the label on your vehicle, always follow the instructions on the vehicle label.

If a label comes off or becomes illegible, contact Champion Motorsports Group for a replacement.

OPERATIONS – GENERAL WARNING

Located adjacent to the steering column.

General warnings for the operations of the golf cart. Serious injury or death can occur if you do not follow the instructions and procedures shown in this owner's manual.



OPERATIONS – GROSS VEHICLE WEIGHT RATING (GVWR)

Located on panel by front bench seat.
Gross vehicle weight rating for the golf cart.



OPERATIONS – MAXIMUM CARGO LOAD / MAXIMUM WEIGHT CAPACITY

Located on panel by front bench seat.
Maximum cargo load / maximum weight capacity information for the golf cart.



OPERATIONS – PASSENGERS

Located on panel by front bench seat.
Important information concerning passengers that ride in the golf cart.



Section 4 Safety Labels cont'd

OPERATIONS – FAILURE TO INSPECT BEFORE OPERATING



Located on dashboard underneath steering column.
Important information concerning vehicle inspection before every ride.

OPERATIONS–ALCOHOL CONSUMPTION



Located on dashboard underneath steering column.
Important information warning against alcohol and drug use during golf cart operation.

OPERATIONS–TIRE PRESSURE

Located on dash adjacent to driver's side cup holder.
Important information concerning golf cart's tire pressure.



OPERATIONS– ROLLOVER RISK

Located on panel underneath steering column, near the brake pedal.
Important information concerning golf cart's rollover risk.

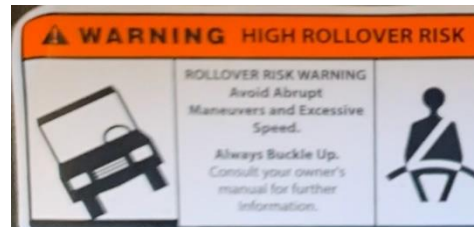

OPERATIONS– BATTERY CHARGING

Located on panel near front bench seat.
Important information concerning golf cart battery charging.

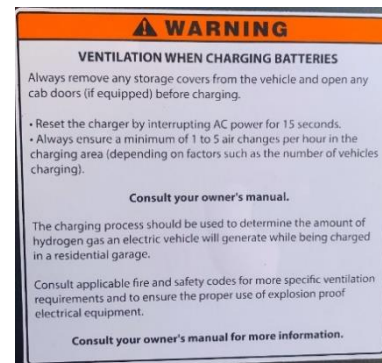

Section 4 Safety Labels cont'd

OPERATIONS– SEATBELT

Located on dashboard, near USB plug.
Important information regarding the use of seatbelts.



OPERATIONS– WINDSHIELD

Located on panel underneath steering column, near the brake pedal.
Important information regarding the windshield.



OPERATIONS– VOLTAGE

Located on panel by front bench seat.
Important information concerning electricity warnings.



OPERATIONS– VOLTAGE

Located on panel by front bench seat.
Important information concerning electricity warnings.



OPERATIONS– BATTERY

Located on charging port door.
Important information concerning battery charging.



Section 4 Safety Labels cont'd

OPERATIONS- BATTERY

Located in charging port door.
Important information concerning
battery charging.



Section 5 Technical specification

Curb weight	1213 lbs.	Max load	838 lbs.
Length	114 in	Width	50 in
Height	82 in	Seat height	17 in
Backrest height	22 in	Wheel track	Front 43 in Rear 41 in
Ground Clearance	6.8 in	Wheel base	67 in
Controller type	alternating current	Rated voltage	48V
Battery type	Lithium battery	Battery capacity	105AH
Voltage	48V	Driving Distance	52 miles
Motor type	AC frequency conversion traction	Motor power	5kw
Charger input voltage	110V-250V	Charging type	Portable battery charger
Rated speed	3000rpm	Charge time	5h-6h
Motor position	In-head/fore rake	Max speed	25 MPH
Max. climbing ability	≤25%	Seating capacity	4
Tire size	23*10-14	Braking distance	≤19.7m
Packing type	Electronic	Front and Rear brake	Disc

Section 6 Parts

1.Left view

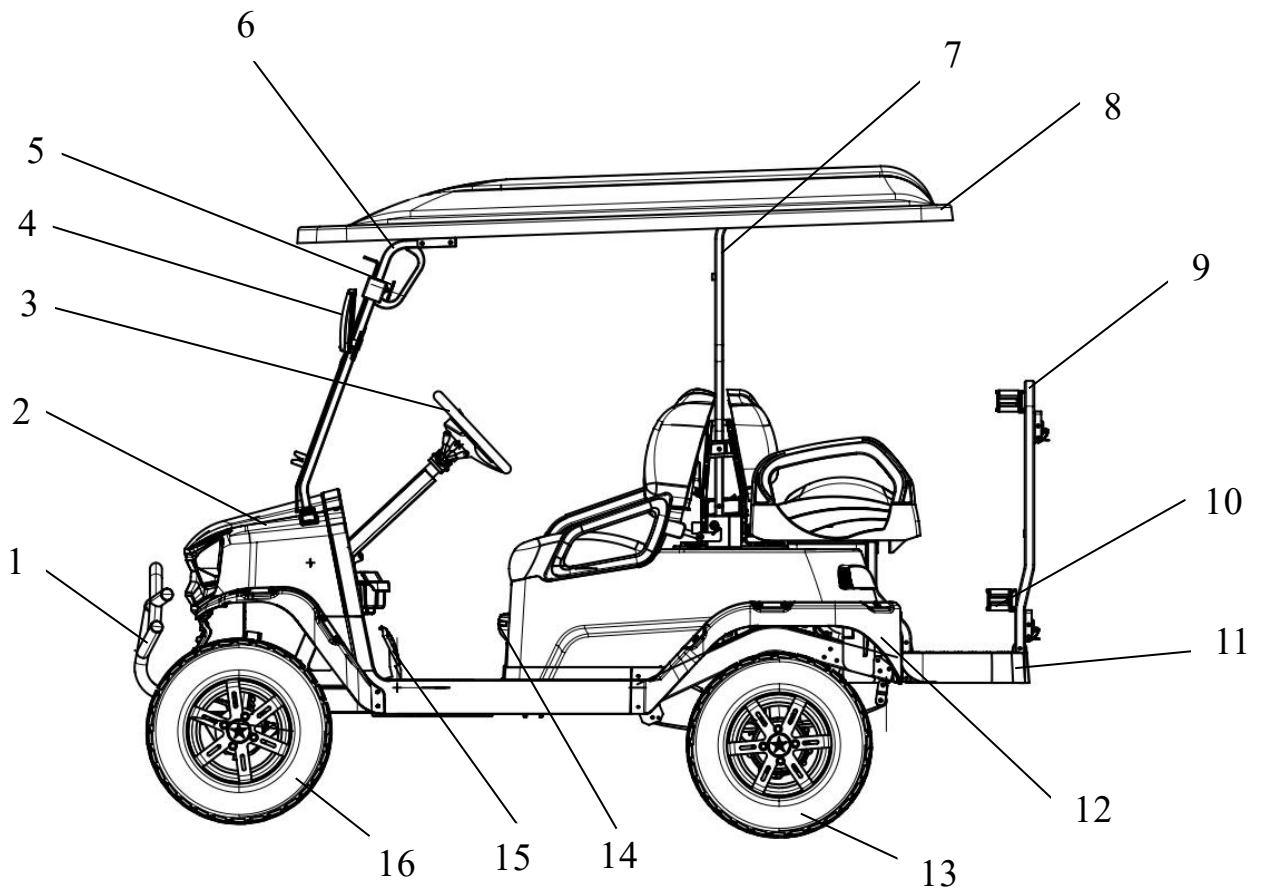

(Figure 1)

1. Bumper 2. Front body 3. Steering wheel 4. Rear view mirror 5. Inner view mirror 6. Top cover front bracket 7. Top cover rear bracket 8. Ceiling 9. Rear tail bracket 10. Ball bag bracket 11. Rear pedal 12. Rear body 13. Rear tire 14. Gear switch 15. Brake pedal 16. Front tire .

Section 6 Parts cont'd

2.Right view

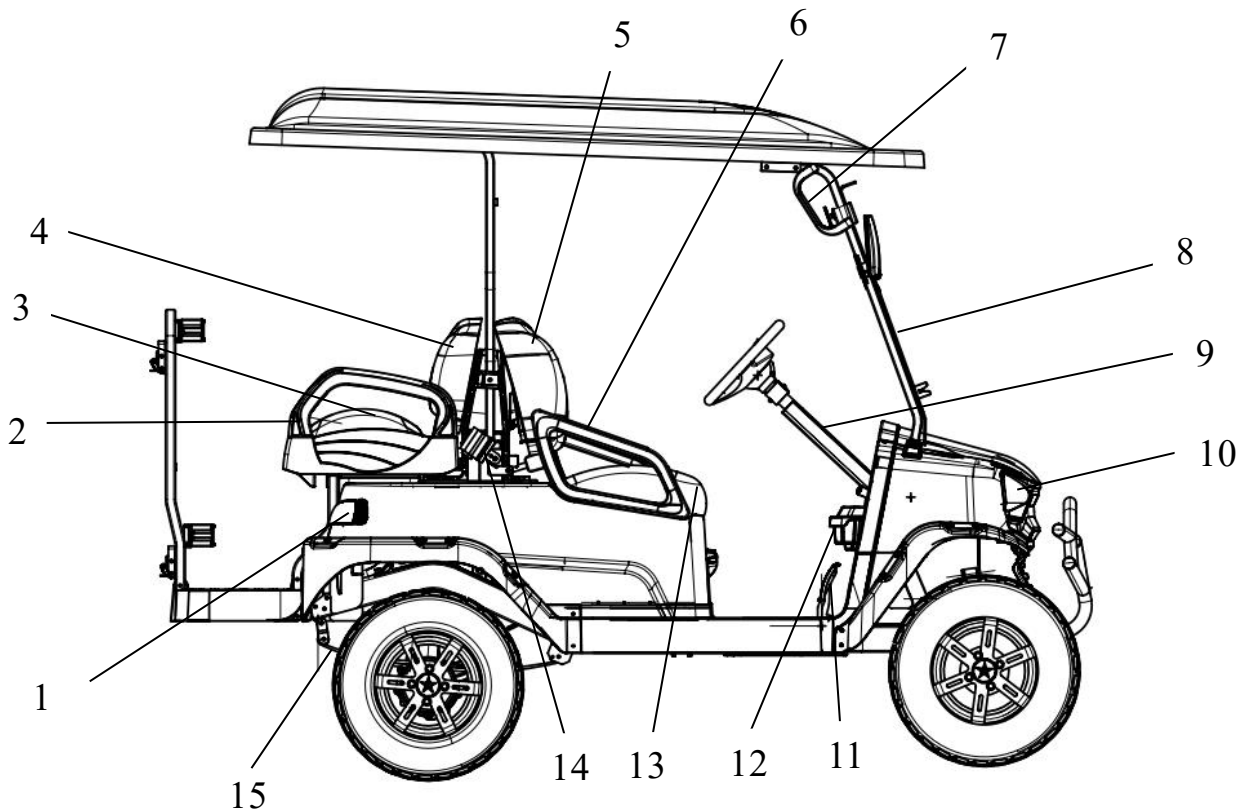

(Figure 2)

1. Taillight 2. Rear armrest 3. Rear seat cushion 4. Rear backrest 5. Front backrest 6. Front handrail 7. Boarding handrail 8. Front windshield 9. Steering column 10. Headlight 11. Accelerator pedal 12. Cup holder 13. Front seat cushion 14. Three-point seat belt 15. After the plate spring

Section 6 Parts cont'd

3.Upward view

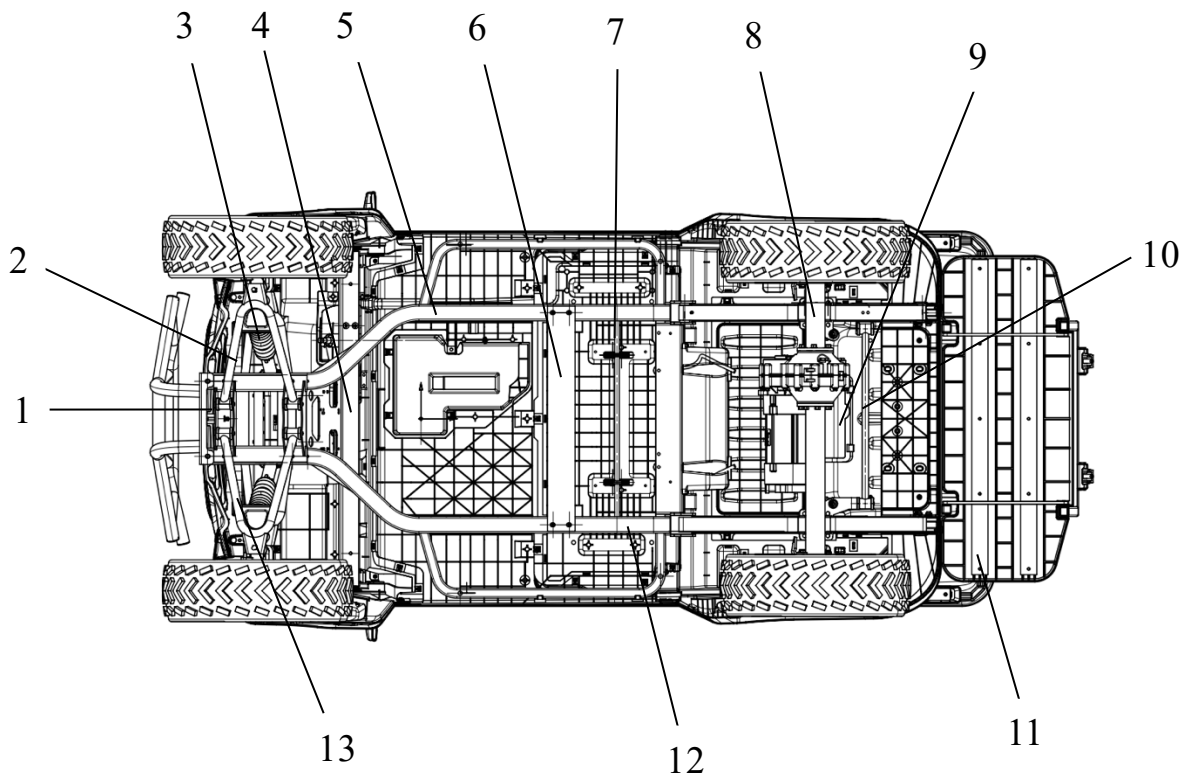

(Figure 3)

1. Swing arm mounting bracket
2. Lower swing arm
3. Front shock
4. Steering column mounting bracket
5. Left carling
6. Brake cable mounting crossbeam
7. Battery mounting shaft
8. Rear axle
9. Motor
10. Stabilizer bar
11. Step support
12. Right carling
13. Upper swing arm

Section 7 Control and functions

1. Electric door lock switch, headlight switch, emergency light switch, USB



Light switch emergency flasher switch electric door lock USB

(Figure 4)

1)The electric door lock switch has two gears. When the switch is in the "ACC" position, the DC converter will work and 12V will start to supply power, which can provide power to the headlights and USB. To start the Golf Cart, simply insert the key and turn it clockwise to the ON position. The controller is powered on and the controller contactor snaps. When the Golf Cart stops running, turn to the OFF position and pull out the key to prevent the non-owner from starting the vehicle.

NOTICE

Some accessories continue to operate with the key in the OFF position. Leaving these accessories activated after the vehicle is shut down can cause the battery to discharge.

2)The headlight switch is on the left side of the center control display, press the headlight once to turn on, and press the headlight again to turn off.

3)The emergency light switch is on the left side of the center control display. Press it and flash the emergency light to work. Press it again and turn off the emergency light.

Section 7 Control and functions cont'd

4)USB is on the far-right side of the panel to provide charging for external electronic products.

NOTICE

Excessive use of accessories that are connected to the outlet can drain the battery.

5)The headlight switch is on the right side of the electric door lock. The headlight switch is a rocker switch.

6)The emergency light switch is on the right side of the headlight switch. Press the upper part of the switch to turn the emergency light on and press the lower part of the switch to turn it off.

7)USB is on the right side of the panel, it can charge external electronic products. USB has 2 charging ports, 5V/1A and 5V/2A.

2.Combination switch

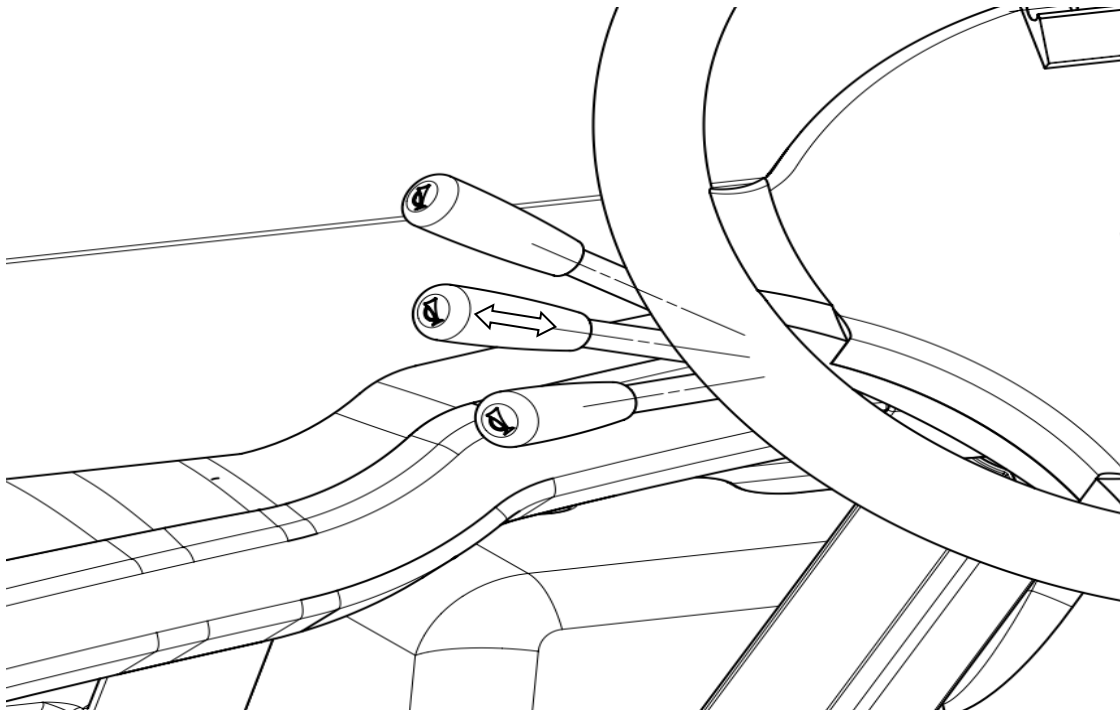

(Figure 5)

Combined switch operation method

Flip the switch forward is turn the turn right signal on, flip the switch down is turn the turn left signal on, combination switch upward is to close the long spot light, combination switch lever tail has a small horn logo, press it, the horn switch work.

Section 7 Control and functions cont'd

3. Gear switch, charging port, charging operation

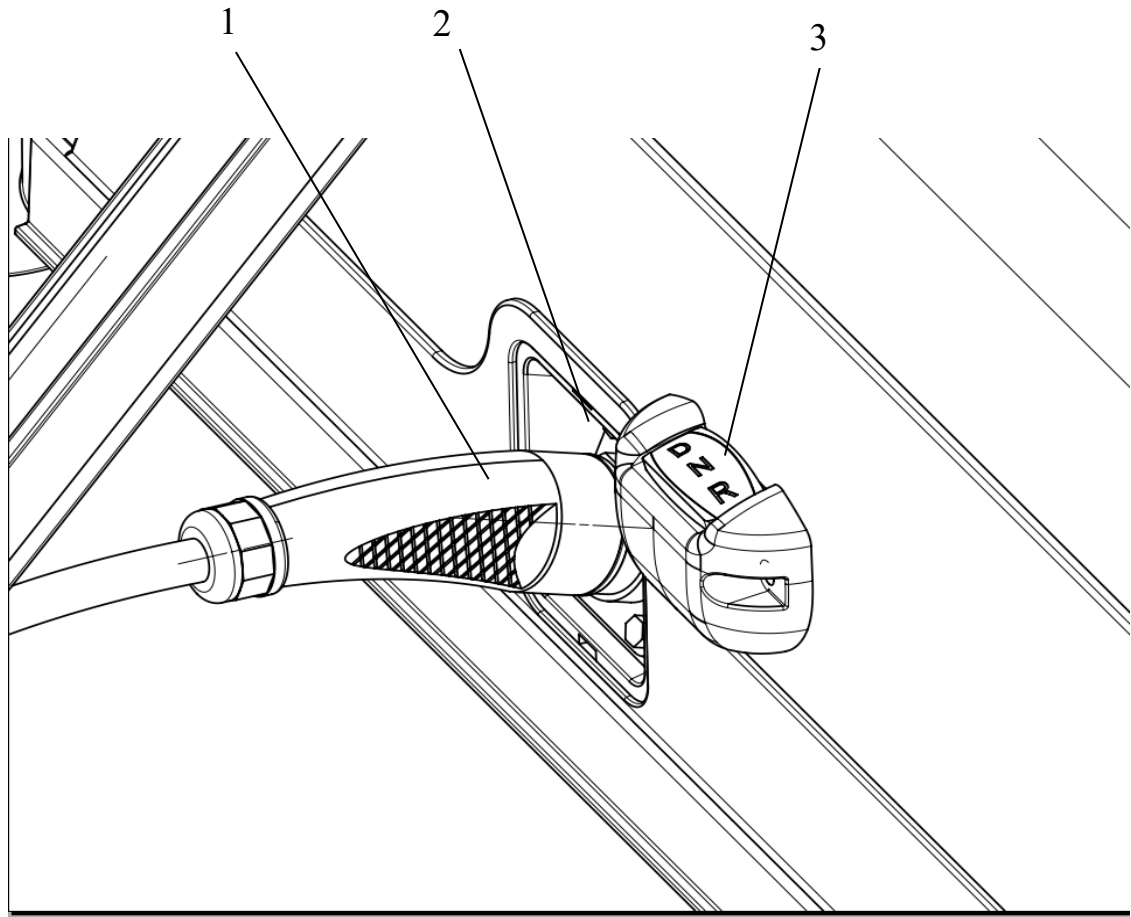

(Figure6)

1.EV charger 2. Charging port 3. Gear switch

Charging instructions: Open the dust cover to insert the EV charger. Note: When charging, the charging gun must be plugged in first. After connecting the AC power for charging, unplug the AC plug first and then unplug the charging gun to avoid wrong operation or damage to the vehicle.

Shift operation, this car used D-N-R shift mode, the gear is in neutral position "N" under normal state, when the shift switch press to "D", the display shows "D", at this time the vehicle is in forward gear; When the shift switch is press to "R", the display shows "R", and the vehicle is in reverse gear.

Section 7 Control and functions cont'd

4. Brake pedal and accelerator pedal

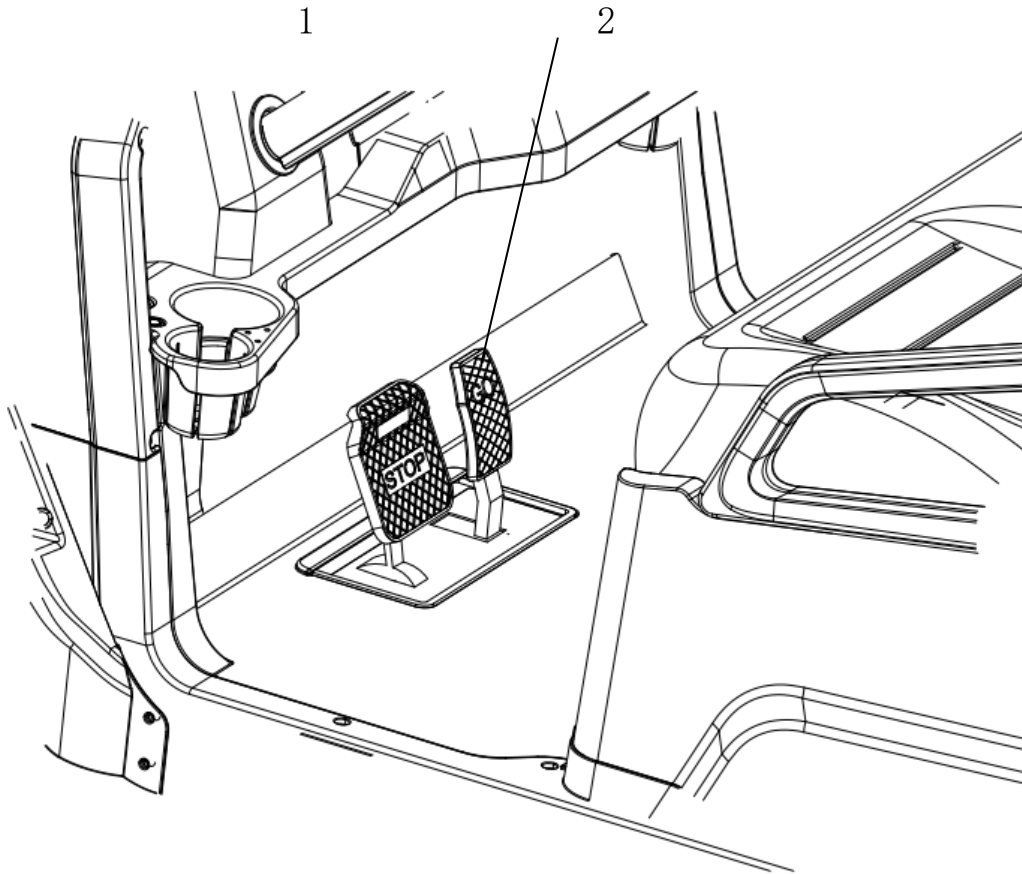

(figure 7)

1. Brake pedal 2. Accelerator pedal

The brake pedal is used for driving brake. In the process of driving, when the brake is needed, it is necessary to release the accelerator pedal GO first, and then press the brake pedal STOP to brake effectively. Once the vehicle is stopped, release the brake pedal and the automatic electronic parking works. When you need to drive, press the accelerator pedal and the parking brake unlocks automatically. The vehicle can then move normally.

Section 7 Control and functions cont'd

5. Open front seat



(figure 8)

Instructions for opening the front seat cushion: Pull up the front armrest to open the seat cushion. Under the front seat cushion is the installation position of the battery pack.

⚠️ WARNING

WARNING: SERIOUS INJURY MAY OCCUR IF THESE INSTRUCTIONS ARE NOT FOLLOWED METICULOUSLY:

- 1. Charge the battery using only the approved charger that is provided with the golf cart.**
- 2. Do not store or operate the battery below -20°C or above 60°C.**
- 3. Avoid flooding or submerging battery in any liquid.**
- 4. Keep the battery away from open flames or sparks.**
- 5. Under no circumstances should the battery be opened, serviced, installed, or removed by anyone other than authorized personnel. Failure to adhere to these instructions may result in injury, fire, or damage to the battery. Please exercise utmost caution and comply with all safety guidelines to ensure the safe and proper use of the battery.**

For prolonged periods of non-use (5 days or longer), the battery must be shut off and safely stored.

Section 7 Control and functions cont'd

6. Open rear seat

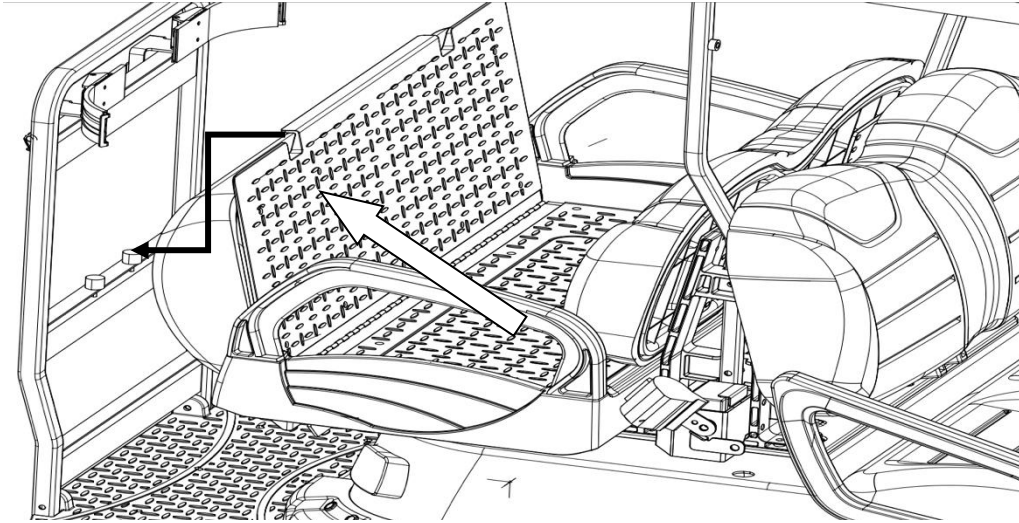

(figure 9)

Operating instructions for opening the back seat cushion: Pull the back seat cushion up, and when the seat cushion is expanded, the rear should hang the cushion on the rear tail rack, so as not to fall off during the driving.



Always fill the forward seating capacity prior to seating any passengers on the rear flip seat.

Rear passengers must stay in the seat with their seat belts securely buckled when the vehicle is in motion. Always make sure that all passengers are seated and holding on before operating the vehicle.

Do not allow passengers to ride on the load deck. A sudden move or stop can cause severe injury or death to passengers on the load deck.

Only two passengers allowed on the rear facing seat. Never leave small children alone on the seat. Always keep both arms and legs inside the vehicle boundary.

Section 7 Control and functions cont'd

7. Tool box

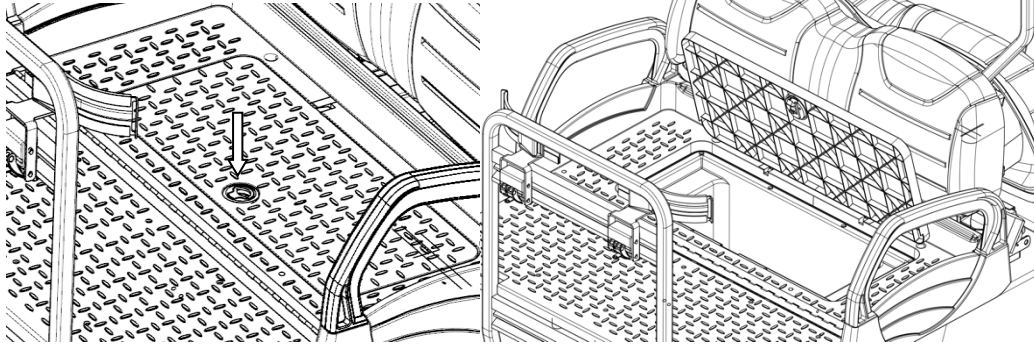

(Figure 10)

(Figure 11)

Operation instructions for opening the toolbox: pull up the toolbox loop (Figure 10) to open it.

8. TFT display

1) Instrument main interface button function

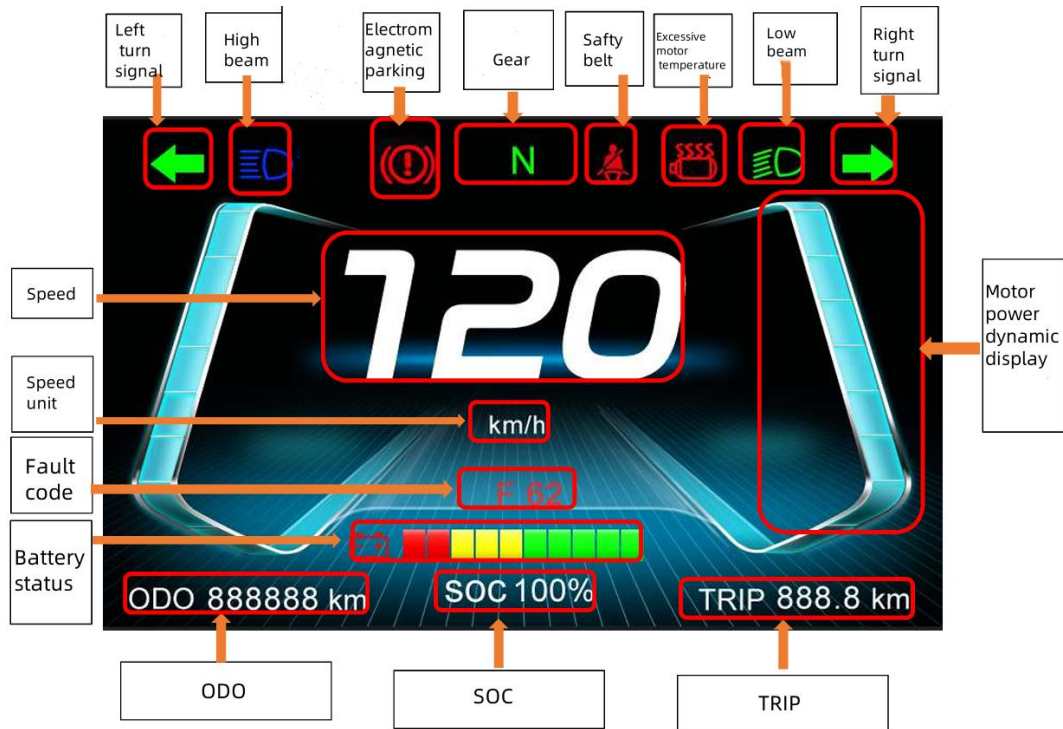

(figure 12)

Section 7 Control and functions cont'd

2) Charging interface

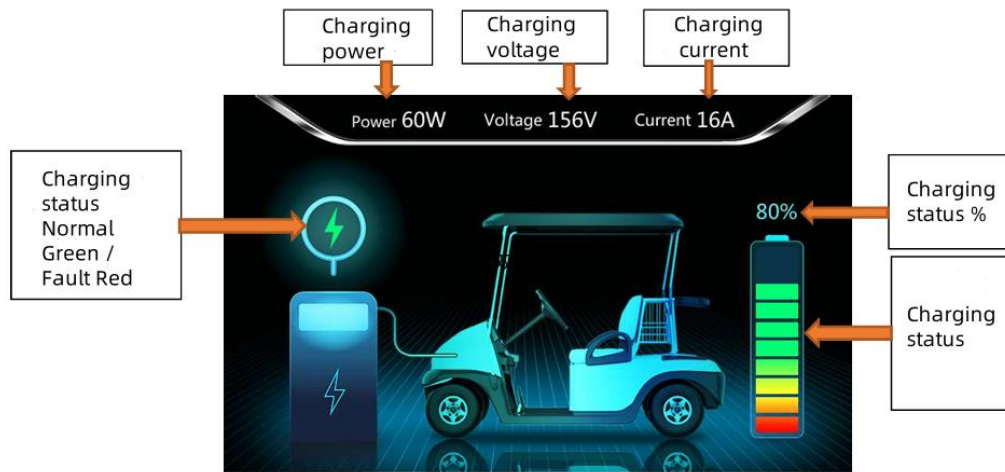



(figure 13)

3) Operation introduction:

3.1 High beam display: After the high beam is turned on, the icon on the TFT display lights up



Otherwise extinguish

3.2 Turn on/off low light: Touch the button  and the low light will be turned on. Touch the button again to turn off the low light. After the low light is turned on, the icon on the TFT display  will light up, the meter will output +12V current $\leq 10A$, and the display will be extinguished, and the relay output will be disconnected after it is turned off.

3.3 Turn on/off emergency light: Touch the  button, the emergency dual flashing light will be turned on, and the left and right turn signal icon on the TFT display will blink at a frequency of 250ms. Touch the button again to turn off the emergency double flash.

3.4 Clearing the current Sub counted Mileage: If you press  for more than 3s, the sub counted mileage will be cleared to zero.

3.5 Switching speed unit: When you touch it  twice within 1S, the MPH will be changed to KMH. Touch it  twice in a row, back to MPH.

Section 7 Control and functions cont'd

4) Error code display:

When the electronic control system fails, the instrument will automatically display the error code, the detailed definition of the error code refers to the controller /BMS Description.

4.1 When the controller fails, the instrument will display the controller fault code in the format of M+FF (FF represents the electric control reporting fault generation Code)

4.2 When BMS fails, the instrument displays the BMS fault code in the format of B+FF (FF represents the fault code of electric control reporting).

5) Gear display:

5.1 The vehicle is in D gear, and the TFT gear position icon  is displayed

5.2 When the vehicle is in N gear, the TFT gear position icon  is displayed

5.3 The vehicle is in R gear, and the TFT gear position icon  is displayed

6) Electromagnetic parking display: the vehicle is in the electromagnetic parking state, the TFT icon is displayed, and the icon  disappears after the electromagnetic parking is removed.

7) Motor overtemperature display: vehicle motor temperature is too high, TFT display  icon, motor temperature drops to normal state after the icon disappears.

8) Seat belt display and prompt: Seat belt is not fastened, speed =0 Light the icon . Seat belt not fastened, speed > 0 Flash this icon at 250ms frequency and drive the horn to sound. Seat belt buckle inserted, turn off this icon

9) Speed display: TFT LCD speed position digital display of the current speed 

10) Speed progress bar display: the TFT LCD screen reports the current speed by electronic control, and displays the current speed synchronously and dynamically in about 8 levels



11) Power progress bar display: the TFT LCD screen reports the data according to BMS, and the current power is displayed dynamically in 10 cells. The TFT LCD screen reports the data according to BMS and displays the current power in percentage digital mode. When the power is in the last cell, the battery icon will blink at a frequency of 250m 

12) Total mileage statistics and display: The instrument calculates the total mileage of the vehicle since use by itself and displays it on the TFT screen. Total mileage cannot be cleared or zeroed out 

Section 7 Control and functions cont'd

13) Subtotal mileage statistics and display: the table calculates the subtotal mileage after the vehicle is powered on to the current time. When the vehicle is powered off, the sub counted mileage will be cleared to zero. Or in the process of use, long press the setting key to clear the sub count mileage **TRIP 888.8 km**

14) System upgrade ports and special functions: 17.1 mini USB2.0 chassis upgrade port. Use the USB software on the PC to download and update the UI or startup LOGO. Total mileage/subtotal mileage will also be cleared

15) Reserved Bluetooth interface, use App to display vehicle status/control vehicle, OTA MCU firmware

16) Long press the low light + double flash button for 10s at the same time, and the system will restore factory Settings. The total mileage is cleared to zero and the unit is restored to the default value of mph

9. Safety belt



(figure 14)

Please fasten your seat belt before driving!



Always fasten your seat belt, whether driver and/or passenger(s). Failure to do so could result in serious injury or death.

Section 7 Control and functions cont'd

10. Manual release switch position of electronic parking

When the vehicle fails to drive normally, please turn on this switch to push the vehicle. When it is necessary to transport the vehicle to the maintenance point, please use the flat trailer to fix the vehicle on the flat truck, and the four wheels are stationary to safely transport the vehicle to the maintenance point. After normal maintenance, please reset the release switch.



Manual
release
switch



THIS PROCEDURE SHOULD ONLY BE TO CLEAR VEHICLE FROM AN UNSAFE AREA AND BE PERFORMED ONLY BY QUALIFIED TRAINED PERSONNEL.

Failure to follow these instructions can result in serious injury or death.

Section 8 Safe driving



Failure to operate the vehicle correctly can result in a collision, loss of control, accident or rollover, and cause serious injury or death. Follow all operation procedures in this section of the manual. Read and comply with all safety warnings in the safety section of this owner's manual.

1. Check before driving

- 1) Turn on the electric door lock and check the battery status to find if you can get the mileage you want.
- 2) Check if the brake is effective by gently pressing the accelerator pedal and then pressing the brake pedal before driving.
- 3) Turn on the combination switch and check whether the left and right turn signals are working.
- 4) Turn on the emergency lights and check whether the front and rear turn signals blink at the same time.
- 5) Observe the rear-view mirrors on both sides to check whether you can see the rear driving situation. If you can't see it clearly, please adjust the position of the rear-view mirror until you can see the road behind you.
- 6) Please fasten your seat belt before driving to ensure your life safety while driving.



Always fasten your seat belt, whether driver and/or passenger(s). Failure to do so could result in serious injury or death.

2. Operation procedure

- 1) Insert the key into the key switch and turn it to the "ON" position.
- 2) Press the forward/backward shift and make sure there are no obstacles on your road.



When the direction selector is moved to the reverse position, a warning alarm will activate to indicate that the vehicle is ready to run in reverse.

Section 8 Safe driving cont'd

3) Press the accelerator pedal gradually, the parking brake unlocks automatically and then the vehicle starts. Press the accelerator pedal down to increase speed. Spring pressure returns the pedal to the rest position when released. Always check that the accelerator pedal returns normally before starting the vehicle.



Accidental movement of the accelerator pedal can cause the vehicle to suddenly move and cause severe injury or death.

Make sure that the key switch is in the OFF position any time the vehicle is parked.

4) When parking, release the accelerator pedal and press the brake pedal with the right foot, the electric vehicle slowly stops, and put the forward/backward shift switch in the "N" neutral position after the vehicle stops.



The speed of the motor is sensed and controlled by the controller.



The speed control system is not an alternative for the brake. Use the brake to control speed and decrease the risk of injury.

3. Driving precautions

1) Driver must be familiar with all controls and operating procedures before operating the vehicle.

2) Before driving, ensure that all passengers are seated with seatbelts fastened and grasp the handrails. Passengers are not allowed to lean out of the vehicle while driving.



Exceeding the weight capacities can cause the loss of vehicle control and possible injury or death.

***Maximum Vehicle Weight Capacity – 838 lbs.
Maximum Rider Capacity – 4 riders***

Section 8 Safe driving cont'd

3) Slow down and drive carefully on slippery, crowded or complicated roads.



Skidding or sliding can cause loss of control. Skidding or sliding can cause rollover if tires have lost traction, then regain traction suddenly. When operating on slippery surfaces, travel at reduced speed to help maintain control of the vehicle.

4) Reduce speed or brake on time when driving on curves and ramps, be careful and avoid accidents.

5) This vehicle is not designed for driving on the highway, it is not allowed to drive on the highway, otherwise the consequences will be serious.

6) The car is manufactured in strict accordance with the vehicle design standards. Avoid making any modifications to the vehicle before or after purchase due to safety regulations.

7) Overcrowd and overload are strictly prohibited.



Exceeding the weight capacities can cause the loss of vehicle control and possible injury or death.

***Maximum Vehicle Weight Capacity – 838 lbs.
Maximum Rider Capacity – 4 riders***

8) It is strictly prohibited to drive the vehicle after drinking, taking stimulants and/or narcotics.

9) The electric vehicle should be parked indoors after use, because if it is placed outdoors for a long time, the rain (in the case of rainy days) will penetrate the vehicle, resulting in electrical parts damage and mechanical parts rust, reducing the service life of the vehicle.

10) The vehicle is not suitable for inclines greater than 12% and longer than 160 feet. The excessive working current may burn out the motor or electric control device, affecting driving safety.

Section 8 Safe driving cont'd

4. Parking

If the driver wants to stop the vehicle, they should release the accelerator pedal, press the brake pedal to stop, put the vehicle into neutral and turn the key to the OFF closed position. This will engage the parking brake.

NOTICE

When parking the vehicle in cold climates (0°C, 32°F), the car should be stored in an enclosed garage.

Park the vehicle away from any source of flame or sparks, including any appliance with a pilot light.

Park the vehicle on a flat surface if possible. If parking on an incline is unavoidable, be sure to chock the wheels as shown in the following illustration to keep the vehicle from rolling.

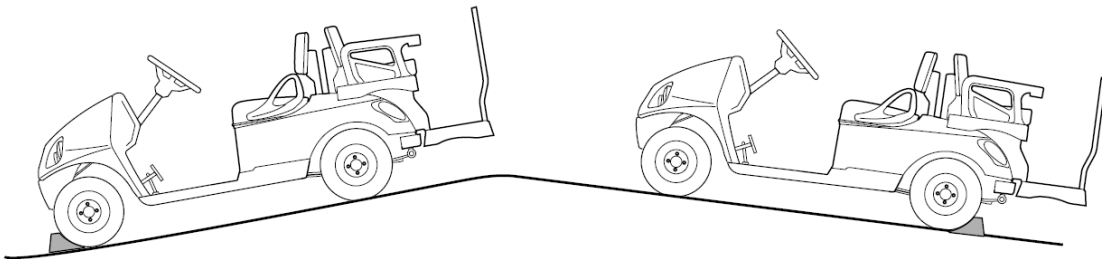

Section 9 Operation warning

1.If you follow our advice for the first 600 miles, you can extend its service life and improve its economic efficiency.

- 1) Avoid sudden acceleration when starting the vehicle.
- 2) Avoid pushing the accelerator pedal frequently.
- 3) Avoid flooring the accelerator.
- 4) Always check whether the battery connection line, electronic control and motor connection and fastening bolts are loose. If they are loose, they should be tightened immediately.



The power AC cord has a plug with a ground post. Do not remove, cut or bend the ground post.

5) It is not allowed to overcharge and discharge the battery, because it will shorten the service life of the battery.



Risk of electric shock. Connect the charger power cord to an outlet that is correctly installed and connected to an electric ground according to all codes and regulations. A grounded outlet is necessary to decrease the risk of electric shock – do not use ground adapters or replace the plug. Do not touch parts of output connector or battery terminals that do not have insulation.

Disconnect the AC plug before you make or break the connections to a battery that is charging. Do not open or disassemble the charger. Do not operate the charger if the AC cord is damaged. Make sure qualified personnel does all repair work to the charger.

6) Check the steering system, front suspension and wheel nuts during the first 300 miles of the vehicle.

Section 9 Operation warning cont'd

2. Vehicle maintenance records

All vehicles must be maintained and recorded regularly to improve the life of the vehicle, reduce costs, increase driving pleasure and ensure safety, which can improve the service life of the vehicle, reduce costs, increase driving pleasure and ensure safety.



Serious injury or death can occur if you do not follow the instructions and procedures shown in this owner's manual.

2.1 Preventive Maintenance

- 1) The maintenance place should be clean, safe, ventilated and equipped with a fire extinguisher.
- 2) When doing maintenance, you need to turn off the power, pull out the key, put the vehicle in park; When repairing the motor, motor controller and high voltage line, the positive battery power supply connection line must be removed to ensure that the main circuit is disconnected and avoid short circuit.
- 3) When the vehicle is lifted, do not stand under the vehicle.



The vehicle must be on a firm and level surface for lifting.

Remain constantly aware that the vehicle is not stable during the lifting process.

Do not get under a vehicle until it's stability on the jack stands is verified; never get under a vehicle while it is on a jack alone.

Do not allow anyone to remain or get on the vehicle at any time during the lifting process or when the vehicle is lifted.

- 4) The battery must be treated carefully, because it contains flammable and explosive gas and sulfuric acid solution, which is toxic and highly corrosive.
- 5) NO Smoking and NO Open Flames near the battery.



Handling any Lithium-ion battery improperly can cause serious injury or death.

Section 10 Steering system maintenance and adjustment

NOTICE

Service and adjustments are important for safe and reliable vehicle operation. If not familiar with safe service and adjustment procedures, have a certified dealer perform the operations.

The revolute joint of the steering system should be injected with grease once a month, and the connecting ball nut should be checked every three months. If loose, tighten it on time.

Check whether the dust cover of each tie rod joint is broken. The broken dust cover is easy to get water and dust in, which will cause the wear of the joint ball head and the failure of inflexible steering. If cracks are found, they should be replaced immediately.

Check the free swing of the steering wheels for steady parking so that the front wheels face straight ahead, and then gently turn the steering wheel. In the case of free swing greater than the rated value, adjustment is required. Note: It only takes a small amount of force to turn the steering wheel.

Section 11 Battery

10.1 Interface Definition

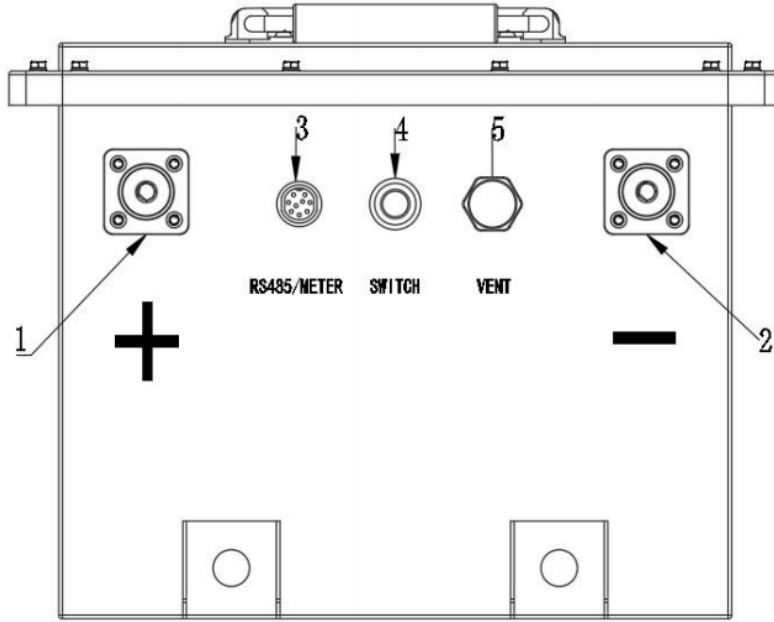

Table 4- 1 Terminal Model and Pin Definition

1. Charge and discharge positive electrode
2. Charge and discharge negative electrode
3. GS16 CAN-L, CAN-H, RS485-B, RS485-A
4. Weak current switch
5. Vent

10.2 Acceptance Standard

Table 5-2 Acceptance Standard

Functional definition	Wire model	Color
Discharge	UL3135 4AWG/UL3135 8AWG	Red, black
Charge	UL3135 4AWG/UL3135 8AWG	Red, black

Section 11 Battery cont'd

10.3 Key Dimension requirements

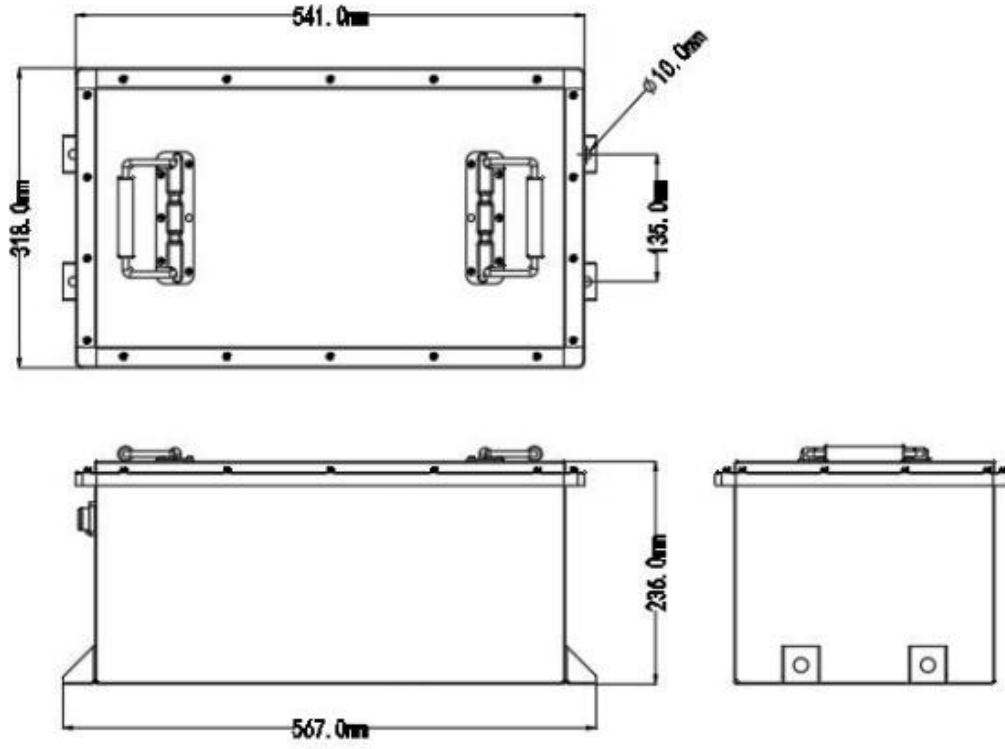

Fig.5-3 Key Dimensions

Section 11 Battery cont'd

10.4 Name plate

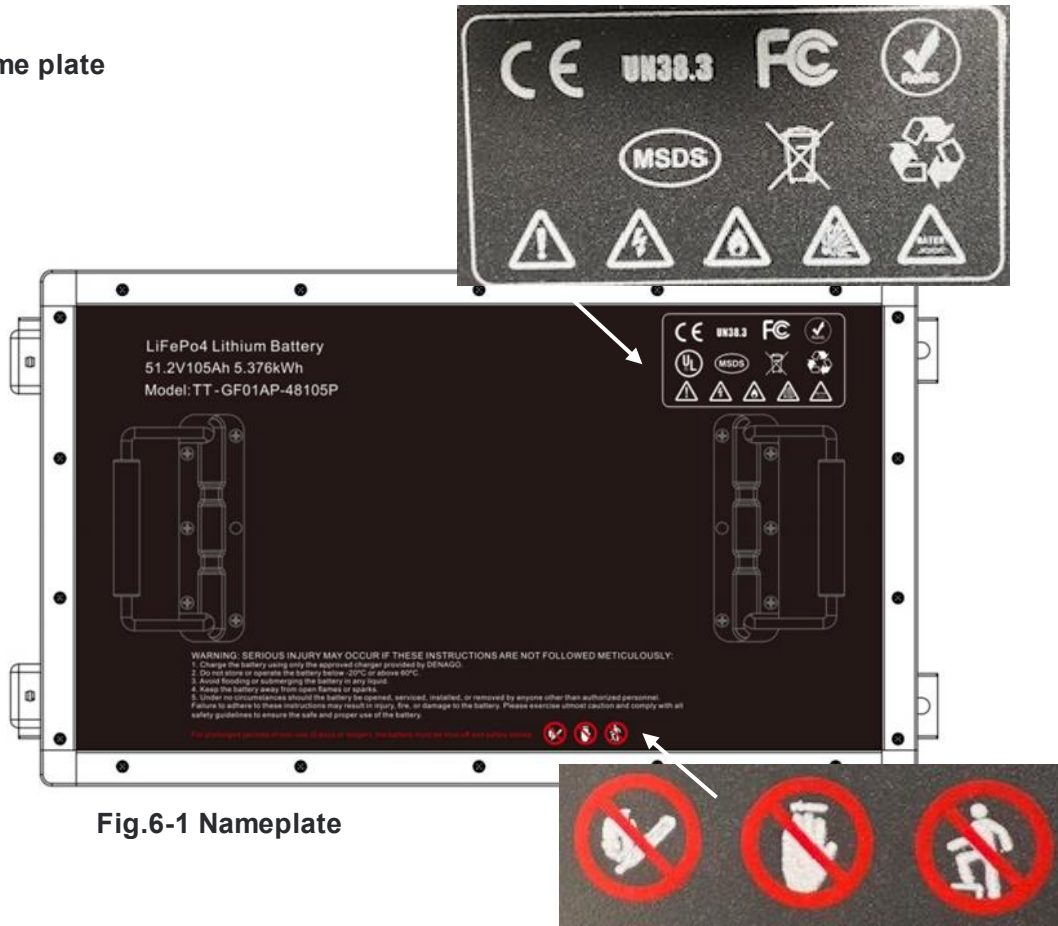

Fig.6-1 Nameplate

⚠ WARNING

WARNING: SERIOUS INJURY MAY OCCUR IF THESE INSTRUCTIONS ARE NOT FOLLOWED METICULOUSLY:

6. Charge the battery using only the approved charger that is provided with the golf cart.
7. Do not store or operate the battery below -20°C or above 60°C.
8. Avoid flooding or submerging battery in any liquid.
9. Keep the battery away from open flames or sparks.
10. Under no circumstances should the battery be opened, serviced, installed, or removed by anyone other than authorized personnel. Failure to adhere to these instructions may result in injury, fire, or damage to the battery. Please exercise utmost caution and comply with all safety guidelines to ensure the safe and proper use of the battery.

For prolonged periods of non-use (5 days or longer), the battery must be shut off and safely stored.

Section 12 Toe-in of Front wheel

1.Keep the front bundle of the front wheel within the range of 2-7mm, if it exceeds the parameter, please adjust the screw calibration of the direction machine. Measurement procedure:

- 1)Straighten the front wheel of the vehicle, mark the front and rear center points of the tire, and measure the distance between the left and right tire marks” B”. As shown in figure 1.
- 2)Push the vehicle forward so that the mark moves to the same position as the measured height. As shown in figure 2.
- 3)Measure the distance between the left and right tire mark and rotate to the front. As shown in figure 3.
- 4) If the tire toe-in is not within the specified range, it can be adjusted by turning the left and right pull rod.

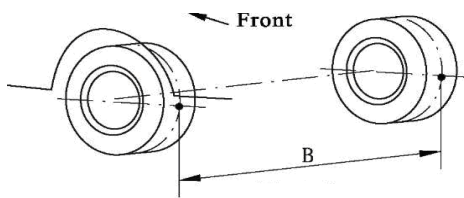

Figure 1

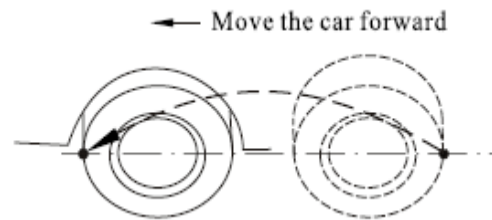

Figure 2

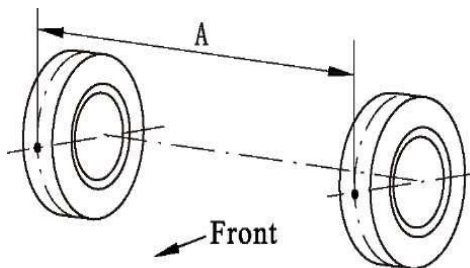

Figure 3

2.Adjust the toe-in of front wheel.

- 1)Loosen the lock nut at the end of the steering tie rod.
- 2)Turn the pull rod left and right, left and right steering wheel of the range of motion should meet the same standard.
- 3) Lock steering tie rod nut.

Note: When measuring the length of left and right steering pull rod, they should be close to each other. The difference between left and right steering bar: ≤ 5 mm.

Section 12 Toe-in of Front wheel cont'd

3.Replacement of lubricating oil for the rear axle main reducer

The lubricating oil of the rear axle main reducer should be changed every two years. It is necessary to check whether there is oil leakage and unscrew the screw plug and check whether the lubricating oil is enough regularly.

- 1)Vehicles must be parked on flat ground during oil level inspection.
- 2)Remove the oil filling port screw plug and check the oil level with your finger. The distance between the oil level and the bottom of the oil hole is not more than 5mm. If the oil level meets the requirements, tighten the oil plug.
- 3)When installing the oil filter plug, look for any oil leakage or damage of rear axle housing.
- 4)If the oil level is low, increase the oil, and then tighten the screw plug.

4. Maintenance of suspension system

The fastening bolts of the suspension system should be checked every three months and tightened on time whenever loosened.

5.Maintenance of braking system

Adjustment the brake pad gap of the front brake hub: Raise the front wheel off the ground, the adjustment ratchet on the brake hub counterclockwise to the tire cannot be rotated by hand, and then the ratchet clockwise to the wheel hub by hand without dragging brake phenomenon shall be subject to. The rear axle brake hub is self-adjusting and doesn't need manual adjustment.

Check the brake fluid level frequently, add when insufficient.



Always inspect the pedal travel before operating a vehicle to confirm some brake function is present.

All driving brake tests must be done in a safe location with regard for the safety of all personnel.



Over time, a subtle loss of performance may take place. It is, therefore, important to establish the standard with a new vehicle.

Section 13 Tire repair and maintenance

1). Check the tread pattern of tire:

The tread pattern groove depth of the tire should be greater than 1.6 mm. When the groove of tire pattern wear is less than 1.6 mm, the tire should be replaced. Check regularly to make sure there are no nails, stones or other similar substances. As shown in figure.

2). Tightening procedures of tire nuts:

When installing the nut on the tire (turn the taper point inward), first push the tire inward with your hand to see if the nut can be tightened further.

Tighten the screws and nuts with the tool according to the number sequence shown in the figure. Tighten a few turns at a time until all the nuts are tight. See below.

NOTICE

Always install lug nuts using a cross-sequence pattern to ensure the even seating of the wheel against the hub.

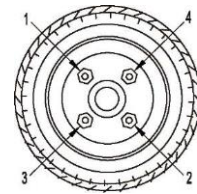

CAUTION

To decrease the risk of component damage, do not tighten the lug nuts to more than the specified torque.

3). Use of tires:

To make the tire uniform use, the tire with the same size and number of tire layers should be replaced every six months in turn to extend the service life of the tire and check the damage degree of the tire surface when replacing the tire. In most cases, serious abnormal wear is caused by abnormal tire pressure, wheel imbalance, or sudden application of braking force to the aligned tread. The front and rear tire pressures must meet standard values and check the degree of tightening of wheel nuts.

4). Change the tires

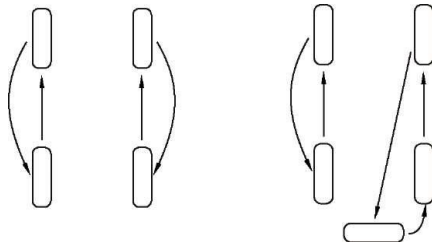

Section 13 Tire repair and maintenance cont'd

WARNING

Worn, improperly inflated, improper sized, or incorrectly installed tires will affect vehicle handling and could cause an accident resulting in severe injury or death.

Inflate all tires to the same pressure. Operating with unequal or incorrect pressure can adversely affect steering and handling and could cause an accident resulting in severe injury or death.

To decrease the risk of tire explosion, do not exceed the tire inflation rating on the tire sidewall. Make sure the tires are properly inflated at all times of operation.

To decrease the risk of tire explosion, inflate small amounts of air into the tire at intervals to allow the bead to seat properly. Because of the low volume of the small tires, over inflation can occur in seconds. Never exceed the tire inflation pressure rating on the tire sidewall when seating a bead. Protect your face and eyes when you remove a valve core.

When you remove the wheels, use only sockets made for impact wrenches to decrease the risk of injury by a broken socket.

Do not use tires with a low rated pressure. Do not use tires that have a recommended tire inflation pressure less than the tire inflation pressure recommended in the owner's manual.

Do not over inflate the tires. Excess pressure can cause the tire to separate from the wheel or cause a tire explosion.

Improper tire pressure or uneven tire pressure can cause loss of vehicle control and possible injury or death.

Tires maintenance or replacement must be completed on a flat, stable surface.

Section 13 Tire repair and maintenance cont'd

NOTICE

For hard surfaces or pavement, inflate to higher pressure with the range; never exceed maximum pressure indicated.

For soft terrain or turn, inflate to lower pressure within the range to reduce potential damage to the terrain or turf.

Tire plug tools and plugs are available at automotive outlets. The tire does not have to be removed from the wheel to install the tire plug.

Section 14 Use and maintenance of motor controller, battery and charger

WARNING

To prevent serious injury or death, follow the procedures and comply with the safety information in this manual while performing vehicle service or maintenance.

Use the tools shown in the tool list and wear the specified safety equipment when performing vehicle service or maintenance.

Remove all jewelry before you service the vehicle.

Do not allow loose clothing or hair to contact the moving parts.

Do not touch hot objects.

Make sure that the key switch is in the OFF position before you start to work on the vehicle.

Disconnect the negative battery terminal before you service the vehicle to prevent accidental operation.

The drive wheels must be lifted and supported on jack stands before you do any service to the powertrain when the motor is in operation.

Chock the wheels and support the vehicle with jack stands. NEVER get under a vehicle that is supported by a jack. Lift the vehicle according to the manufacturer's instructions.

Wear a face shield when working arounds the battery pack.

Be careful when working around batteries, using solvents or compressed air.

Section 14 Use and maintenance of motor controller, battery and charger cont'd

WARNING

Use insulated tools within the battery area to prevent sparks or blowing the BMS fuse which will require service by an authorized dealer.

To prevent the risk of battery explosion, keep all flammable materials, open flames or sparks away from battery.

Maintain constant awareness that some components are heavy, spring loaded, corrosive, explosive, can cause high amperage or get extremely hot.

After you make repairs or do maintenance, test the vehicle in a safe area that is free from vehicle and pedestrian traffic.

NOTICE

After you connect a battery or any other wires, wait a minimum of 30 seconds before you move

1. Power supply should be cut off during inspection and maintenance to avoid accidents.

- 1). Do not place flammable materials such as paper, clothing, etc. on or near the motor controller because of the heat generated by the motor controller.
- 2). Avoid having liquids around the motor controller. Motor controller should be kept dry.
- 3). Check the wiring connection of the motor controller every month and tighten it on time if it is loose.
- 4). When the motor is replaced and reconnected, the armature and motor end should not be incorrectly connected, otherwise the motor controller will be damaged.
- 5). When the battery is charged, the key switch should be turned off and taken away to ensure that the charging circuit and motor controller are cut off
- 6). It is forbidden to step on the accelerator pedal urgently or frequently, so as not to shorten the service life of the accelerator control system.

Section 14 Use and maintenance of motor controller, battery and charger cont'd

WARNING

Improper handling of batteries and electrical components can result in serious injury or death.

Do not remove battery pack cover. Do not attempt to remove batteries or battery cables. Do not use the battery pack without the control module installed. All battery and electrical service must be performed by an authorized service facility.

All tools used in or around the battery pack area should be insulated. Do not intentionally cause a short to the power terminal (P+,P-,B+,B-) with a metallic object.

Do not use the vehicle or charge the battery pack if the battery pack has become abnormally hot, is discolored, deformed, leaking or has an odd odor. If liquid from the battery pack leaks onto skin or clothes, wash well immediately with fresh, running water. If liquid gets into the eyes do not rub the eyes. Wash the eyes with fresh, running water and seek medical assistance immediately.

Do not cut, tear or remove the seal tape. Do not disassemble or modify the design, including the electrical circuit, of the battery pack or control module.

To prevent the risk of battery explosion, keep all flammable materials, open flames or sparks away from the batteries. Do not leave the battery pack near a fire or heat source. Do not throw Lithium-Ion batteries into a fire. Do not apply heat to any part of the battery pack or battery management module with a soldering iron. Do not place the battery pack in a microwave oven, dryer or high-pressure container.

Make sure that the key switch is in the OFF position before you start to work on the vehicle.

Section 14 Use and maintenance of motor controller, battery and charger cont'd

WARNING

Do not attempt to operate the vehicle or charge the battery pack at temperatures above 140°F (60°C).

Do not immerse or throw the battery pack in water. Do not pressure wash the battery pack.

Do not puncture the battery pack or control module. Do not strike the battery pack with a hammer or heavy weight. Do not step or stand on the battery pack. Do not throw or drop the battery pack on hard surfaces.

If the battery pack terminals are contaminated or dirty, clean them with a dry cloth before using the battery pack.

Keep the battery pack and control module away from static electricity.

Before recycling or shipping battery pack, make sure that the battery pack terminals are insulated.

Do NOT use an extension cord with the charger.

2.To ensure personal and equipment safety, operators should follow the following precautions:

- 1) Special trained personnel shall be required to replace, maintain and charge batteries.
- 2) Do not place conductive objects on the battery to prevent short circuit of the battery. Clean the dust and dirt on the battery cover frequently to prevent the filling hole cover or the air hole on the screw plug from being blocked. If a solid oxide is found on the pole, remove it so as not to affect the conductivity between the pole and the terminal. After cleaning up, wipe the battery surface clean, and put butter on the pole and terminal to ensure that the pole is not oxidized.
- 3) When the battery power is insufficient, it is strictly prohibited to start the vehicle; When the battery is being used, over-discharge and high-current discharge for a long time should be avoided, otherwise it will reduce the service life of battery.
- 4) When charging the battery, the temperature of the electrolytes should not exceed 113°F. If it does, stop charging and wait for the temperature to drop before continuing to charge.

Section 14 Use and maintenance of motor controller, battery and charger cont'd

5) Battery charging will produce flammable and explosive gas. Open flame is strictly prohibited in the charging area. Do not charge if the battery, plug and/or receptacle are hot to the touch.

6) Check whether the battery connection is loose or damaged before starting the vehicle each time. Any worn, cut or damaged wires must be replaced immediately. Contact Champion Motorsports Group for a service location near you for replacement. Ensure that the connection of the charging cables is completely secure while in use. Do not use if the cable connection is loose, bent, or corroded.

7) Do not let any dust fall into the battery, check and wipe the air hole frequently to prevent the battery seal cover ventilation blockage.

8) If the battery is not used for a long time, it should be maintained and charged once a month, otherwise it will cause the battery plate to vulcanize. If the battery is not maintained for a long time, the capacity and life of the battery will be seriously affected.

9) It is strictly prohibited to adjust or twist the terminals during the operation of the vehicle to prevent the battery explosion caused by sparks.

10) During the battery inspection and measurement process, do not step on or put pressure on the battery cover, liquid injection cover and other battery parts to prevent damage.

11) Never charge the battery when the environmental temperature is below 36°F as this will cause irreversible damage to the battery cells.

12) After the battery is discharged (regardless of the vehicle's driving time and mileage), the battery should be recharged on the same day.

13) Do not attempt to charge frozen batteries or batteries with bulged cases. Frozen and/or bulging batteries can explode.

14) Using a defective charger and/or battery could result in a fire, property damage, personal injury, or death.

3. Charging

1) The charger should be placed in a safe working environment, free of dust, corrosive gas, rain and temperature not higher than 104°F.

2) Firmly insert the plug of the charger and the battery bank according to the polarity, and then connect the input power of the charger to charge the battery. Do NOT use an extension cord with the charger.



The use of an extension cord with the charger could start a fire that results in property damage, personal injury or death.

Section 14 Use and maintenance of motor controller, battery and charger cont'd

3) Do not use an adapter to plug the charger with a three-prong plug into a two-prong outlet. Improper connection of the equipment-grounding conductor can result in a fire or an electrical shock.

4) Place all cords so they will not be stepped on, tripped over, or otherwise subjected to damage or stress.

5) The vehicle is equipped with an automatic intelligent charger, which can fully charge the battery bank without personnel monitoring. After the battery is fully charged, the charger will automatically shut down.

6) Good ventilation should be maintained during charging to avoid explosion caused by hydrogen accumulation.

7) When maintaining batteries, use tools with insulated handles to prevent battery short circuit and personal injury.

8) Requirements for input power of the charger:

Voltage: single AC 100V-230V

Power socket: 16A

Conductor cross-sectional area ≥ 2.5 square mm

NOTICE

Do not spray the battery module with water. Do not attempt to add water to the battery module.

To reduce the risk of electric shock, the battery charger must be grounded. The charger is equipped with an AC electric cord having an equipment-grounding conductor and a grounding type plug. The AC plug must be connected to an appropriate receptacle that is properly installed and grounded in accordance with the National Electrical Code and all local codes and ordinances.

⚠ WARNING

Never allow a lithium battery to drop below 10% state of charge or the battery will go into protection mode requiring the battery to be sent back to the factory for a reset and recharge to restore the battery to working order at owner's expense.

Section 14 Use and maintenance of motor controller, battery and charger cont'd

CAUTION

On all vehicles, turn off all accessories before charging batteries.

The battery charger provided with this vehicle is approved for use only with the battery type originally shipped with the vehicle. Using a different battery type (different brand, different capacity, etc.) can cause under or overcharging and subsequent battery damage unless the charger is first reprogrammed with a new charging algorithm.

4. Battery Disposal

NOTICE

When Li-ion batteries are put into a municipal / household recycling bin, they are taken to a municipal recovery facility (MRF) that is typically equipped to recycle only household paper, plastic, metal and glass. At an MRF, Li-ion batteries may be damaged or crushed during processing and can become a fire hazard.



The chasing arrow symbol on Li-ion batteries means they are recyclable at specialized battery recyclers; it does NOT mean Li-ion batteries can be put in the municipal / household recycling bin.

WARNING

Do not dispose of Li-ion batteries in household or shop garbage / recycling bins. They can cause fires during transport or at landfills and recyclers.

Before recycling or shipping battery pack, make sure that the battery pack terminals are insulated.

Section 14 Use and maintenance of motor controller, battery and charger cont'd



Always recycle Lithium-ion batteries:

- ***Contact the distributor or manufacturer for information on returning or recycling used or damaged battery packs.***
- ***Contact local or state environmental department for disposal information.***

5. Clean the Golf cart

- 1) The exterior of the vehicle body can be cleaned with soapy water and a sponge to remove dirt on the surface of the body. Avoid using abrasive cleaner to avoid damage to the paint layer.
- 2) When cleaning the bottom of the car, pay special attention to the electrical parts, especially the driving motor, controller, etc., absolutely do not let water infiltration, so as not to lead to the reduction of electrical insulation, electrical damage.

NOTICE

Do not use a pressure washer to wash the vehicle. High water pressure can damage components.

Some products, including insect repellents and chemicals, will damage plastic surfaces. Do not allow these types of products to contact the vehicle.

Section 14 Use and maintenance of motor controller, battery and charger cont'd

6. Transporting the Vehicle



Do not ride or allow other people on a vehicle being transported on a trailer or being towed with another vehicle.

Loose cargo or vehicle components can fly off when the vehicle is being transported. Secure or remove all cargo. Inspect the vehicle for loose components prior to transport.

Do not allow anyone to ride in a vehicle being transported on a trailer.

Remove the windshield before you transport the vehicle on a trailer.

Remove the roof or secure with straps or tie downs before you transport the vehicle on a trailer.

- If the vehicle is being hauled on a trailer or truck at highway speeds, the rooftop and windshield must be removed.
- The rated capacity of the hauling trailer or truck must be more than the weight of the vehicle and load plus 1000 lbs. See SPECIFICATIONS for the weight of the vehicle.
 - 1) Drive the vehicle onto the trailer or truck.
 - 2) Leave the direction selector in F(forward).
 - 3) Turn the key switch to the OFF position.
 - 4) To prevent the loss of the key, remove it from the key switch.
 - 5) Make sure the seats are secured.
 - 6) Secure the vehicle to the trailer or truck with tie downs, straps or ropes.

Section 15 Trouble shooting

1.Mechanical fault

Fault	Reason	Solution
The tires wear unevenly	Low tire pressure	Inflate to recommended air pressure
	Wrong toe-in	must be aligned to properly operate the toe
Motor noise	Bearing abrasion	Change the bearing
The steering is not flexible enough	Steering box cover water or grease solidification	Clean the cover, replace gasket and Inject proper lubricating oil
	Hinge lack of grease	Replenish grease
	Rack out of shape	Adjust the rack
Steering wheel is prone to jitter	Uneven air pressure of the tires	Adjust tire pressure
	Wobbling of wheels	Repair or replace
	Rim nut loose	Tighten the nut
	Wheel bearing wear or damage	Replace
Braking force is inconsistent	Uneven air pressure of the tires	Adjust tire pressure
	Wheel braking force is uneven	Adjust the braking pad
Braking force is not enough	Braking pad wear seriously	Replace the braking pad
	Poor contact between brake pad and brake hub	Adjust clearance, repair worn parts and improve the connection.
	Braking pad has dust or water	Clean
Reverse drag won't work	Controller broken	Check the controller and replace the related parts

Section 15 Trouble shooting cont'd

2.Electrical faults

Fault	Reason	Solution
When turn the key switch on, the battery power does not display, and the contactor has no sound	The key switch is disconnected	Repair or replace
	The circuit connector is loose or cutting out	Tighten the ends or connect the wires
	Battery joint oxidation	Clean with abrasive paper
	Circuit burnt out	Replace
	Wrong connect for positive and negative	Makes the connect right
When turn the key switch on, the battery power does not display, and the contactor has sound	The accelerator doesn't return to the right position	Replace
	Gear switch fault	Repair or replace
	Accelerator fault	Repair or replace
	Speed controller fault	Repair or replace
	Motor fault	Repair or replace
Damp or drenching of the controller	Inspection and drying	
The vehicle is stop-and-go	Over-current or overheating protection system starts	Check and exclude whether the PSPK board opened, whether it has been carried and climbs uphill for a long time.
Flame out immediately after starting	Out of power	Charge the battery
	Motor fault	Check and repair
The golf cart can't start	The key switch is on the off location, or the forward/reverse shift switch is on the neutral location	Turn the key to the ON position to select the driving direction of the shift switch
	Battery has no power	Test the density of the battery electrolyte and recharge it.
	Battery wiring electrodes are corroded or loose	Clean the corroded parts and tighten the connecting nuts
	The key switch wire is loose or damaged	Tighten the wire and repair the key switch
	Microswitch broken	Replace the microswitch
	Contactor fault	Repair or replace contactor
The battery cannot be charged	Motor fault	Inspect faulty parts, repair or replace it
	Charger fault	Check the fault of the charger, repair or replace parts
	The connection wire is loose or detached	Check and tighten the nut
	Battery fault	Replace the battery
	The charging voltage is too low	Adjust the charging voltage
The speed instability	Over discharge of the battery caused a complete blackout	Test and adjust the battery electrolyte density, Replace the electrolyte or battery pack if necessary
	Accelerator fault	Replace the accelerator

Section 15 Trouble shooting cont'd

3. Battery fault

Fault	Characteristics	Reason	Solution
Capacity reduction	Less than rated capacity or insufficient capacity	Insufficient recharge or charge after use	Balanced charging and improved operating methods
		The external line is not smooth, and the resistance is large	Straighten out the external lines to reduce resistance
		Partial battery short circuit	Eliminate
	Sudden decrease in capacity	Internal or external battery short circuit	Check the cause and rule it out
Voltage anomaly	When the battery is charging, the voltage is high, and the voltage is quickly reduced during discharge	Plate sulfation	Eliminate plate sulfation
	When the battery is in use, the open circuit voltage is significantly reduced	Reverse pole, short circuit	Check the single battery voltage and exclude

Section 16 Fault information

Note: A "B" is displayed before the fault code, indicating a BMS fault.

Signal Name	Fault code	18F28F4 Fault code	Perform the action	Part
Serious overtemperature alarm	1	1	Alarm, fault level report, fault code 01. The discharge current limit is 0, and the high voltage process is taken under discharge. Disconnect all relays.	BMS
Total voltage ultra high	1	2	Alarm, report fault level, fault code sent 02. Discharge and feedback are prohibited, and the high voltage process under discharge is adopted. Disconnect all relays;	BMS
Total voltage ultra low	1	3	Fault level report, fault code sent 03. The discharge current limit is 0, and the high voltage process is taken under discharge. Disconnect all relays;	BMS
The discharge is seriously overcurrent	1	4	Alarm, fault level report, fault code 04. The discharge current limit is 0, and the high voltage process is taken under discharge. Break all relays	BMS
Severe hypermonomer	1	5	Alarm, report fault level, fault code sent 05. Discharge and feedback are prohibited, and the high voltage process under discharge is adopted. Disconnect all relays.	BMS
The monomer is severely low	1	6	Alarm, fault level report, fault code 06. The discharge current limit is 0, and the high voltage process is taken under discharge. Disconnect all relays.	BMS
Discharge low temperature	1	8	Alarm, fault level report, fault code 08. Discharge current is executed according to SOP power limit meter, and the high voltage process under discharge is carried out. Disconnect all relays;	BMS
Discharge temperature difference	1	9	Alarm, Fault level report, fault code 9. Discharge current limit is 0.	BMS
Voltage difference of discharge unit	1	10	Alarm, Fault level report, fault code sent 10; Discharge current is executed according to SOP power limit meter 10%,	BMS
Charge overcurrent	1	11	Alarm, fault level report, fault code 11, Drop the charging current to 0A, power off according to the charging flow chart, and disconnect all relays.	BMS
Feedback overcurrent	1	12	Alarm, fault level report, fault code 12, No feedback, constant high voltage relay	BMS
SOC low	1	13	Alarm, fault level report, fault code 13. Discharge current is executed according to SOP power limit meter	BMS
Overtemperature alarm	2	21	Alarm, fault level report, fault code 21, Discharge current is executed according to SOP power limit meter	BMS
Low temperature alarm	2	22	BMS report, motor power limit to 50%	BMS

Cell low voltage	2	24	Alarm, Fault level report, fault code 24. Discharge current is executed according to SOP power limit meter.	BMS
Overcurrent	2	25	Alarm. Fault level report, fault code 25, Discharge current is executed according to SOP power limit meter 50%	BMS
The BMS internal communication fault	2	26	Alarm. Fault level report, fault code 26.	BMS
Low SOC	2	27	Alarm. Fault level report, fault code 27. Discharge current executes % according to SOP power limit meter	BMS
The battery pressure difference is large	2	28	Alarm. Fault level report, fault code 28. Discharge current is executed according to SOP power limit meter 50%.	BMS
Large battery temperature difference	2	29	Alarm. Fault level report, fault code 29. Discharge current is executed according to SOP power limit meter 60%.	BMS
Total discharge low	2	31	Fault level report, fault code 31. Discharge current is executed according to SOP power limit meter 20%.	BMS
Charge overcurrent	2	32	Alarm. Fault level report, fault code 32. At the same time the charging current is reduced to 8A	BMS
Feedback overcurrent	2	33	Alarm. Fault level report, fault code 33; The feedback current is executed according to SOP power limit meter 10%	BMS
The temperature sensing cable falls off	2	37	Alarm, fault level report, fault code 37.	BMS
Low SOC	3	61	Alarm. Fault level report, fault code 61. Discharge current is executed according to SOP power limit meter	BMS
The battery pressure difference is large	3	62	Alarm. Fault level report, fault code 62. Discharge current is executed according to SOP power limit meter 70%	BMS
Large battery temperature difference	3	63	Alarm. Fault level report, fault code 63.	BMS
Precharge failure	3	72	Alarm, fault level report, fault code 72. Follow the discharge/charge power-off process and disconnect all relays.	BMS
Discharge high temperature	3	73	Alarm. Fault level reported, fault code sent 73	BMS
Discharge low temperature	3	74	Alarm. Fault level reporting, fault code 74, Discharge current is executed according to SOP power limit meter	BMS
Charging high temperature	3	75	Alarm. The fault level is reported. The fault code is 75	BMS
Charging low temperature	3	76	Alarm. Fault level reported, fault code 76	BMS
Low discharge cell	3	78	Alarm. Fault level report, fault code 78. Discharge current is executed according to SOP power limit meter 50%	BMS
Total discharge low	3	80	Fault level report, fault code sent 80. Discharge current is executed according to SOP power limit meter 50%	BMS
Charge overcurrent	3	81	Alarm. Fault level report, fault code 81; At the same time the charging current is reduced to 16A	BMS
Continuous	3	82	Alarm.; Fault level report, fault code 82.	BMS

discharge overcurrent			Discharge current is executed according to SOP power limit table 80%	
Feedback overcurrent	3	83	Alarm, fault level report, fault code 83. The feedback current is executed according to SOP power limit meter 50%	BMS
The voltage bar falls off	3	89	Alarm, fault level report, fault code 89. In the driving state, the discharge current limit is 0. In the charging state, the charge limit is 0, and the charging stops. According to the discharge/charge power-off process, cut off all relays.	BMS
Cell low	3	90	Alarm, fault level report, fault code 90; Power off according to the charging flow chart, cut off all relays;	BMS
Heating failure	3	91	Alarm, fault level report, fault code sent 91; According to the discharge/charge power-off process, cut off all relays;	BMS
The temperature of the charger is faulty	3	93	The BMS requests the charger to stop charging, and the meter displays the fault code	BMS
Battery connection of the charger is faulty	3	99	The BMS requests the charger to stop charging, and the meter displays the fault code	BMS

Note

1. When multiple levels of fault occur at the same time, as long as the code of the highest level of fault is reported (for example, when level 1 and level 2 faults occur at the same time, only the fault code of Level 1 fault is reported).
2. If multiple faults occur in the same fault level at the same time, the fault codes are issued in turn with a rotation period of 1.

Section 17 Lithium Battery Warranty

The lithium battery in your new Champion Motorsports Group vehicle has a two-year warranty. The warranty is limited to malfunction of the battery. Damage of any kind to the battery which would include water damage or any physical damage to the battery other than scratches can void the warranty. The decision to warranty the battery is solely up to Champion Motorsports Group. Champion Motorsports Group will not withhold replacement of the battery under warranty, unless physical damage or evidence of neglect to the battery is apparent. The battery is warranted for two years without prorating. Champion Motorsports Group will also endeavor to inspect the battery from the inside to determine if the battery has been tampered with or damaged in any other way to determine warranty coverage.

Battery Tips:

- There is an on/off button on the side of the battery on the driver's side. The battery should be charged when the battery is on. Turn the battery off when storing the cart for long periods of time or even overnight. This will save the charge on the battery and extend the charge duration.
- Leaving the battery on for extended periods can cause battery to drain or go into sleep mode. If this happens, turn the battery off, wait 3 minutes and turn the battery back on.
- Never attempt to work on the battery for any reason. This will void your warranty.
- Make sure you do not run the battery until it is totally dead. This will lock up the electromagnetic park brake and you won't be able to move the cart. This can also damage the brake and the motor.
- The cart will go into economy mode when the battery is less than 20% charged. When this happens, the car will slow down to around 10 MPH. This alerts you that the battery will need to be changed soon.
- Make sure you always charge the battery to 100 percent whenever possible.
- **Never charge batteries below 36°F as this will cause irreversible damage to the battery cells and void the warranty.**



Never allow a lithium battery to drop below 10% state of charge or the battery will go into protection mode requiring the battery to be sent back to the factory for a reset and recharge to restore the battery to working order at owner's expense

Section 18 Manufacture Warranty

Limited Warranty

TWO YEAR

THE WARRANTY

Champion Motorsports Group offers the following warranty to the initial purchaser of this new RACKA product. The initial purchaser is defined as the first person to purchase a new RACKA product from an Authorized Retailer.

The limited warranty period for this product is **2 YEARS** from the date of the purchase as shown on the original sales receipt.

WHAT IS A DEFECT?

The Product is warranted to be free from manufacture defects in material and workmanship for a period of **2 YEARS** from the date of purchase shown on the sales receipt. During this period of time Champion Motorsports Group will, at its option, either repair, refund the purchase amount, or replace any original RACKA unit/part which is covered by this warranty that is proven to be defective in workmanship or material.

TO QUALIFY FOR THIS WARRANTY THE PRODUCT:

1. Must have been purchased from Champion Motorsports Group or from an Authorized RACKA Retailer.
2. Must not have been used in a manner inconsistent with the intended use of the vehicle such as competition or used in a manner not consistent with the intended use for the vehicle which would also include rental or commercial use.

WHO CAN PERFORM REPAIRS UNDER THIS WARRANTY?

Repairs under this warranty should be performed by an Authorized RACKA Retailer or comparable servicing dealer.

HOW TO GET SERVICE UNDER THIS WARRANTY

To get warranty service, call Champion Motorsports Group at 972-235-8600 for the location of your local service retailer/dealer. Please do not return the product to the retailer where the product was purchased unless instructed to do so by Champion Motorsports Group. The retailer of this product does not make any warranty on behalf of Champion Motorsports Group without the approval of Champion Motorsports Group. **A COPY OF YOUR VEHICLE SALES RECEIPT IS REQUIRED FOR WARRANTY SERVICE.**

WHAT THIS WARRANTY DOES NOT COVER

This warranty does not cover the following:

1. Damage to lack or improper maintenance as described in this manual.
2. Damage which is caused by normal use and not caused by a defect in materials or workmanship.
3. Use of the product which is not consistent with the intended use as described in the operating instructions.
4. Any expendable maintenance items which need replacement or service as normal maintenance requires unless these normal maintenance items become defective prior to their normal life due to a material defect or a defect in workmanship.
5. Any product which has been altered or modified in a manner not consistent with the original design of the product or in a manner not approved by Champion Motorsports Group.
6. Wear and tear or other maintenance components are not included in the warranty. This includes but not limited to: tires, clutches, belts, rubber boots, & batteries.
7. Damage or failures due to abuse, neglect, or misuse of the product.

LIMITATIONS OF THIS WARRANTY

This warranty does not cover, and Champion Motorsports Group disclaims any responsibility for:

1. Loss of time or loss of use of the product.
2. Transportation costs to and from the authorized center.
3. Other loss or damage to other equipment or personal items.

LENGTH OF IMPLIED WARRANTIES

Any implied warranties are limited to the duration set forth in this warranty. Champion Motorsports Group does not make any claim as to the merchantability or fitness for a particular purpose which would extend longer than the duration of this written warranty.

Check your State Laws, as some State Laws do not allow limitations as to the duration of an implied warranty. Some States may also not allow limitation or exclusions based on incidental or consequential damages.