



BIG BEAR POWER

GX COMMERCIAL LLC

4301 S VALLEY VIEW BLVD. STE 10 AND 11

LAS VEGAS, NV 89103

725-274-6171

BBC62 ASSEMBLY MANUAL



REVISED 06-23-2024

STEP 1

PART INSPECTION

- 1. REMOVE THE TOP AND SIDES AND PARTS FROM THE CRATE**
- 2. UNPACK ALL PARTS AND CHECK THAT YOU HAVE EVERYTHING.**
- 3. LEAVE THE HEAVY ENGINE TRANSMISSION ON THE PALLET**
- 3. MISSING PARTS? CALL 725-274-6171 GX COMMERCIAL PARTS DEPT**

LEAVE THE HEAVY ENGINE TRANSMISSION ON THE PALLET FOR THE NEXT STEP

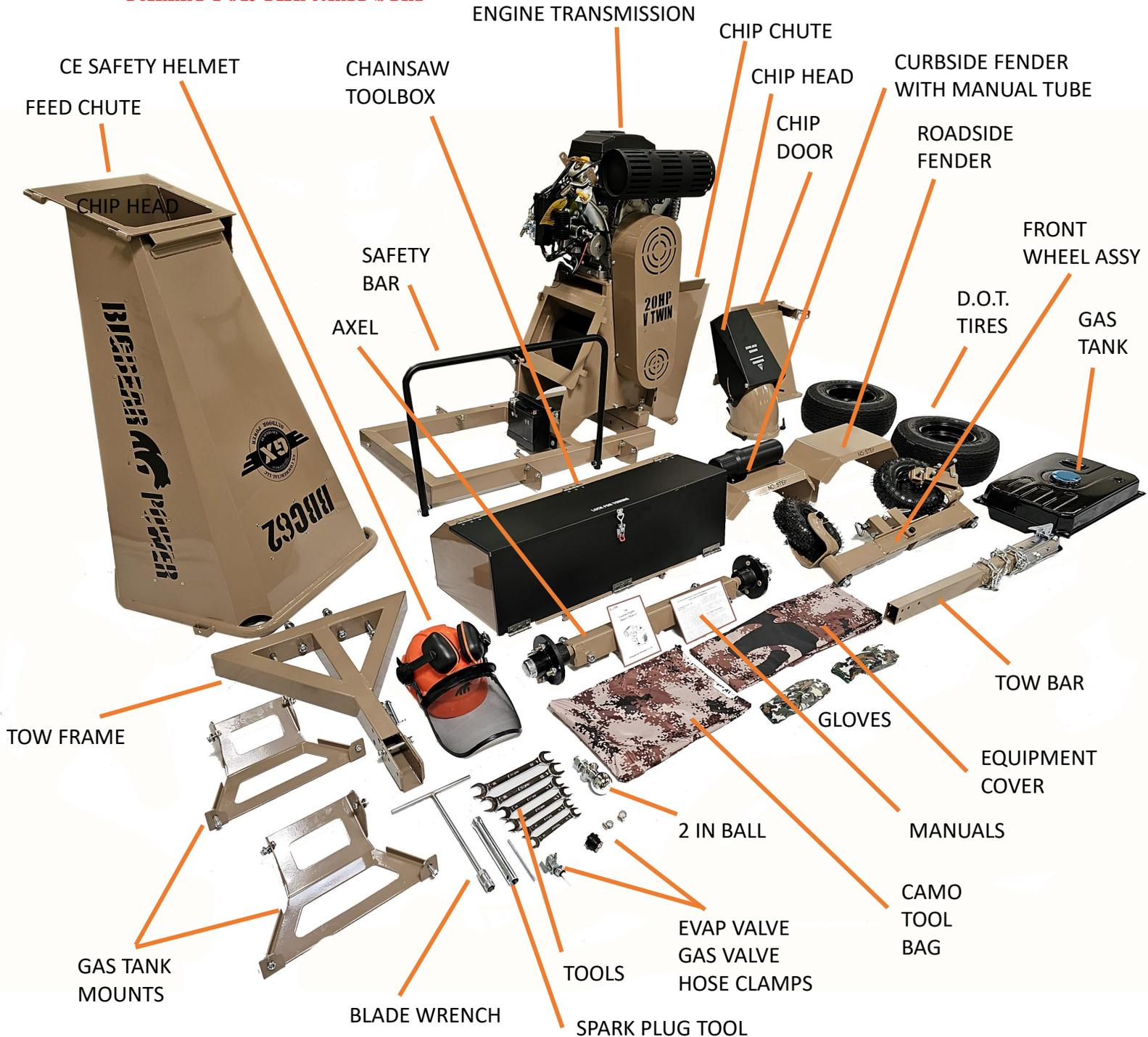

STEP 2

PRE-DEPLOYMENT

- 1. LEAVE THE ENGINE TRANSMISSION ON THE PALLET**
- 2. WE RECOMMEND YOU ENLIST A HELPER TO ASSEMBLE THIS MACHINE**



MISSING PARTS? CALL 725-274-6171 GX COMMERCIAL PARTS DEPT

STEP 3

INSTALL FEED CHUTE

1. PLACE FEED CHUTE TO SIDE OF MACHINE AS SHOWN AND LIFT
2. ALIGN PINS INTO HINGES – **2 PERSONS ARE RECOMMENDED** FOR THIS STEP AS THIS FEED CHUTE IS HEAVY AND THEY CAN HELP ALIGN THE HINGES
3. CLOSE THE FEED CHUTE AND LATCH
4. HOLDING THE CHUTE ROTATE THE ASSEMBLY 90 DEGREES EXTENDED OFF THE PALLET AS SHOWN



MISSING PARTS? CALL 725-274-6171 GX COMMERCIAL PARTS DEPT

STEP 3

INSTALL CHIP DOOR

- 1. IMPORTANT REMOVE NUTS AND BOLTS FROM DOOR BEFORE MOUNTING. THIS PREVENTS HARDWARE BEING DROPPED INTO THE CUTTING DRUM DURING STEP 4. REMOVE NUTS AND BOLTS AND LAY ASIDE.**
- 2. INSTALL THE CHIP DOOR ONTO THE HINGES**
- 3. CLOSE AND LATCH**

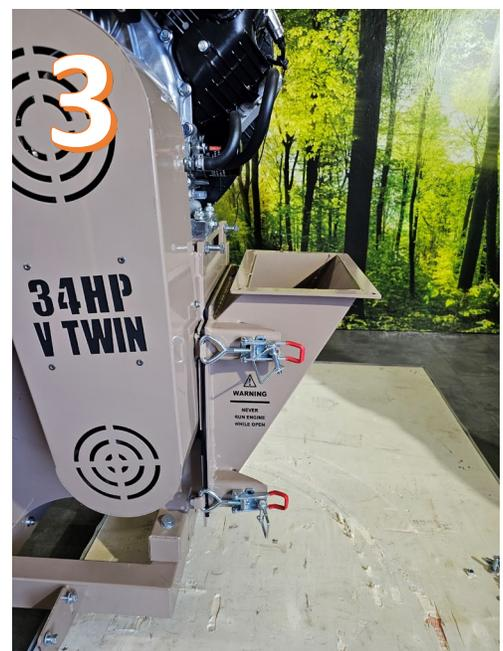
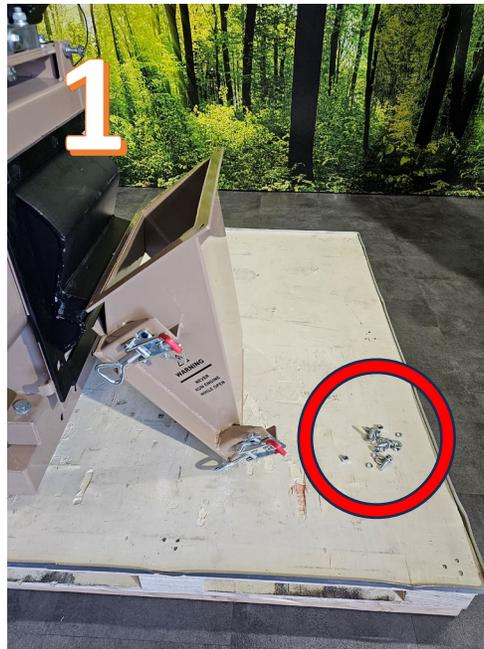

MISSING PARTS? CALL 725-274-6171 GX COMMERCIAL PARTS DEPT

STEP 4

INSTALL HIGH VELOCITY DEPLOYMENT CHIP CHUTE

- 1. IMPORTANT – DO NOT DROP HARDWARE INTO CHUTE DURING THIS STEP**
- 2. PLACE CHIP CHUTE ONTO CHIP DOOR THEN LOOSELY ASSEMBLE HARDWARE**
- 3. SQUARE UP CHUTE ON THE DOOR AND SECURELY TIGHTEN ALL HARDWARE**



MISSING PARTS? CALL 725-274-6171 GX COMMERCIAL PARTS DEPT

STEP 5

CHIP HEAD ASSEMBLY

1. LOOSEN 3 TOOLES CLAMPS
2. MOUNT CHIP HEAD ONTO THE DEPLOYMENT CHUTE AND TIGHTEN CLAMPS
3. TIGHTEN CHIP SHIELD ADJUSTING CLAMPS



MISSING PARTS? CALL 725-274-6171 GX COMMERCIAL PARTS DEPT

STEP 6

INSTALL AXEL – 2 PERSONS RECOMMENDED FOR THIS STEP AS THE MACHINE NEEDS TO BE BALANCED FORWARD HELD SECURELY DURING AXLE INSTALLATION

- 1. TIP THE MACHINE FORWARD NOT TO FAR – PROTECT THE LATCH FROM BEING BENT ON THE PALLET FLOOR.**
- 2. POSITION AXEL WITH MOUNTING HOLES IN POSITION SHOWN**
- 3. LOOSELY INSTALL BOLTS TO ONE SIDE – NUT ON THE BOTTOM**
- 4. INSTALL OTHER SIDE**
- 5. TIGHTEN ALL BOLTS AND SEAT NUTS ONTO LOCK WASHERS SECURELY**



WARNING
PROTECT LATCH FROM BEING BENT ON THE PALLET FLOOR.

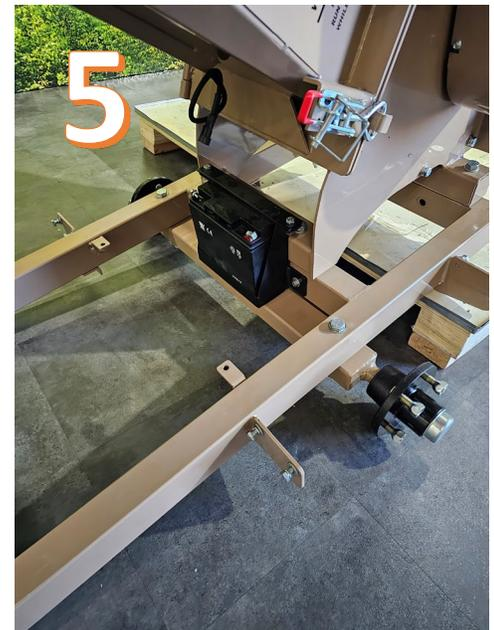
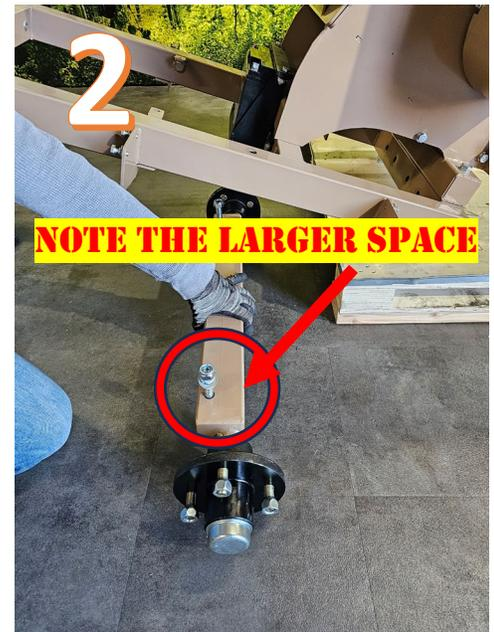

MISSING PARTS? CALL 725-274-6171 GX COMMERCIAL PARTS DEPT

STEP 7

MOUNTING THE WHEELS

1. REMOVE THE WHEEL NUTS FROM THE AXLE SPINDLES
2. INSTALL THE WHEEL WITH THE NUT TAPER TOWARD THE RIM
3. TIGHTEN THE RIM NUTS
4. REPEAT FOR THE OTHER WHEEL
5. LOWER WHEELS TO THE GROUND AND TIP THE UNIT BACK
6. REMOVE THE PALLET FROM THE WORK AREA

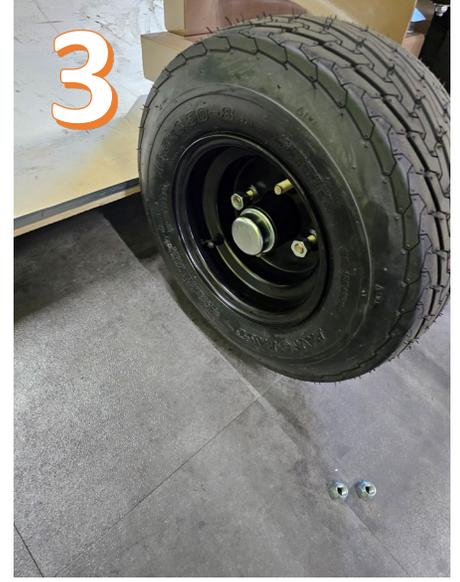

MISSING PARTS? CALL 725-274-6171 GX COMMERCIAL PARTS DEPT

STEP 8

INSTALL TOW FRAME – 2 PERSONS RECOMMENDED

1. ASSEMBLY HELPER SECURELY KEEPS UNIT TIPPED BACK
2. OPEN CHIP CHUTE TO PROVIDE FRONT WORKING SPACE. **BE CAUTIOUS OF DRUM BLADES AT ALL TIMES.**
3. READY THE TOW FRAME NOTE BOLT DIRECTION AND OPEN CHANNEL UP
4. BOLT THE TOW FRAME IN PLACE – **BE CAUTIOUS OF DRUM BLADES AT ALL TIMES**



MISSING PARTS? CALL 725-274-6171 GX COMMERCIAL PARTS DEPT

STEP 9

INSTALL THE FLIP AND STOW TOW BAR

1. **PULL THE TOW BAR PIN AND REAR BOLT FROM THE TOW FRAME CHANNEL**
2. **INSTALL THE TOW BAR – REINSTALL THE BOLT AND PIN LOCK**
3. **TIGHTEN THE LOCK NUT**
4. **CLOSE AND LATCH THE CHIP CHUTE**



MISSING PARTS? CALL 725-274-6171 GX COMMERCIAL PARTS DEPT

STEP 10 INSTALL FRONT AXLE WHEELS **2 PERSONS REQUIRED**

- 1. ENSURE NUTS ARE TIGHTENED ON SPRING PULLS**
- 2. CHECK BOTH PINS FOR SMOOTH OPERATION**
- 3. PREPARE THE AXLE ASSEMBLY**
- 4. LIFT AXLE INTO PLACE AS SHOWN**
- 5. ALIGN PULL PINS WITH HOLES IN FRAME AND LOCK IN PLACE**
- 6. INSTALL LONG BOLT INTO REAR HOLE AS SHOWN AND TIGHTEN**
- 7. PULL PINS AND DROP WHEELS INTO DOWN LOCKED POSITION**



STEP 11

INSTALL FENDERS

1. **INSTALL CURB SIDE FENDER – NOTE THE MANUAL HOLDER IS PRE-INSTALLED. **DO NOT INSTALL THIS FENDER ON THE ROADSIDE.** THE FEED CHUTE WILL INTERFERE WITH THE MANUAL HOLDER WHEN UNLATCHED AND OPENED.**
2. **INSTALL 2 BOLTS IN THE REAR**
3. **INSTALL 2 BOLTS IN THE FRONT**
4. **REPEAT FOR THE ROADSIDE FENDER**



MISSING PARTS? CALL 725-274-6171 GX COMMERCIAL PARTS DEPT

STEP 12

INSTALL ELECTRICAL CONNECTIONS

1. DURING THIS PROCEDURE REMOVE THE KEY FROM KEY START AND CLOSE AND LOCK ALL CHUTES. DISCONNECT THE SPARKPLUG WIRE.
2. LOCATE THE MAIN WIRES FROM THE ENGINE AND POSITION AS SHOWN
3. CONNECT THE SAFETY BAR SHUT OFF UNTIL THE PLUGS LOCK TOGETHER
4. CONNECT RED POSITIVE + AND GREEN GROUND
5. TIGHTEN THE RED TERMINAL **DO NOT** ALLOW THE WRENCH TO TOUCH METAL TO GROUND
6. TIGHTEN THE GROUND GREEN WIRE
7. THE HOUR METER RUNS OFF THE SPARK PLUG WIRE. ONLY ONE WIRE CONNECTION IS REQUIRED, THE OTHER WIRE HAS NO CONNECTION.
8. CONNECT THE SPARKPLUG WIRE AND REINSERT YOUR ENGINE KEY

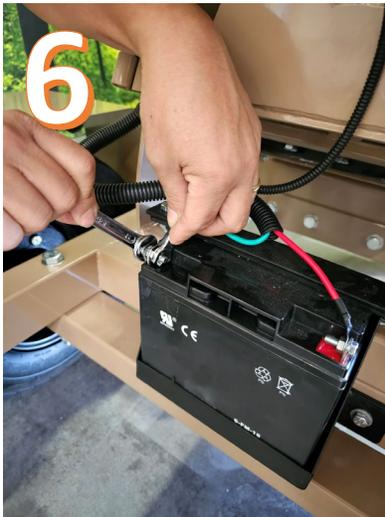
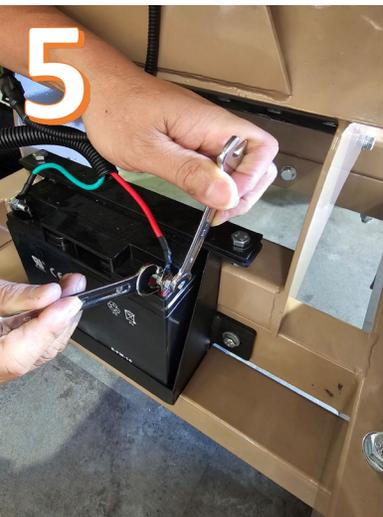

STEP 13

INSTALL CHAINSAW TOOLBOX

- 1. REMOVE ALL MOUNTING HARDWARE FROM TOOLBOX AND POSITION AS SHOWN**
- 2. INSTALL 1 SIDE LOOSELY**
- 3. INSTALL 2ND SIDE LOOSELY**
- 4. INSTALL 2 BOLTS IN REAR OF TOOLBOX TO THE FRAME**
- 5. TIGHTEN ALL BOLTS SECURELY**



STEP 14

PREPARE THE GAS TANK FOR MOUNTING

1. **READY PARTS – EVAP VALVE, GAS VALVE, HOSE CLAMPS**
2. **INSTALL EVAP VALVE – ORIENT HOSE TUBE AS SHOWN – PRESS VALVE INTO PLACE ON THE TANK**
3. **INSTALL GAS VALVE AND ORIENT GAS CONNECTION TUBE AS SHOWN BEFORE TIGHTENING**



STEP 15

INSTALL TANK MOUNTS TO THE ENGINE

1. **INSTALL THE RIGHT-HAND AND LEFT-HAND GAS TANK BRACKETS TO THE ENGINE AS SHOWN**



STEP 16A

ROUTE THE EVAP HOSE

- IF YOUR EVAP HOSE NEEDS TO BE ROUTED HERES HOW TO DO IT
- SOME UNITS ARE ALREADY PRE-ROUTED IN PRODUCTION.

1. REMOVE THE FRONT TOP ENGINE PANEL
2. FIND THE EVAP HOSE AND ROUTE IT TO THE MUFFLER SIDE OF ENGINE
3. EXIT THE HOSE AS SHOWN
4. AFTER THE TANK IS INSTALLED, THE HOSE WILL CONNECT TO THE VALVE.

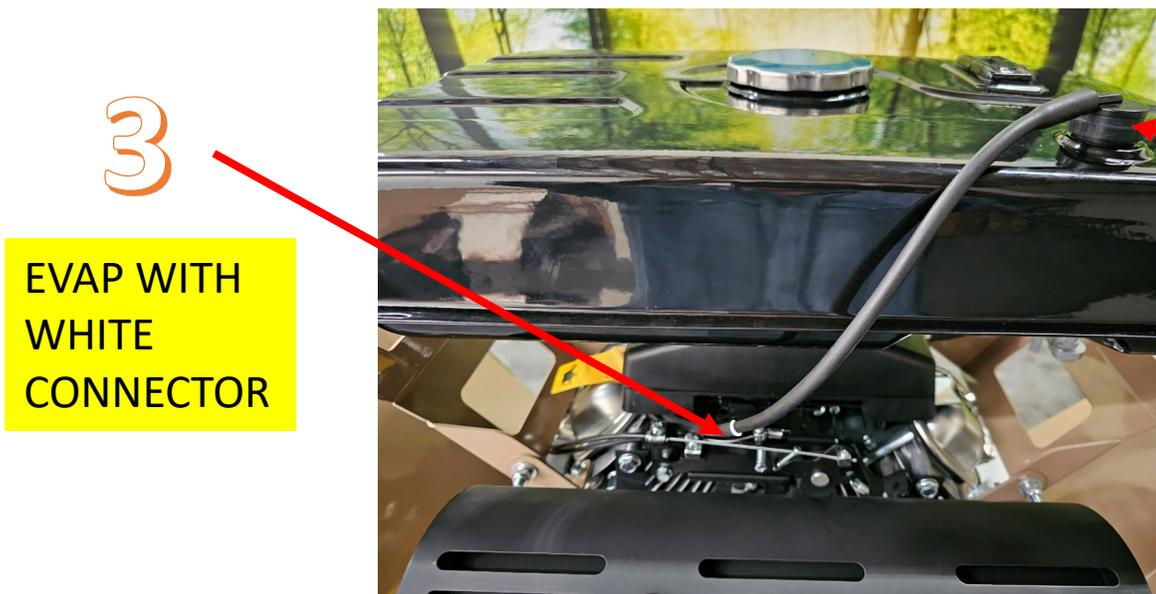
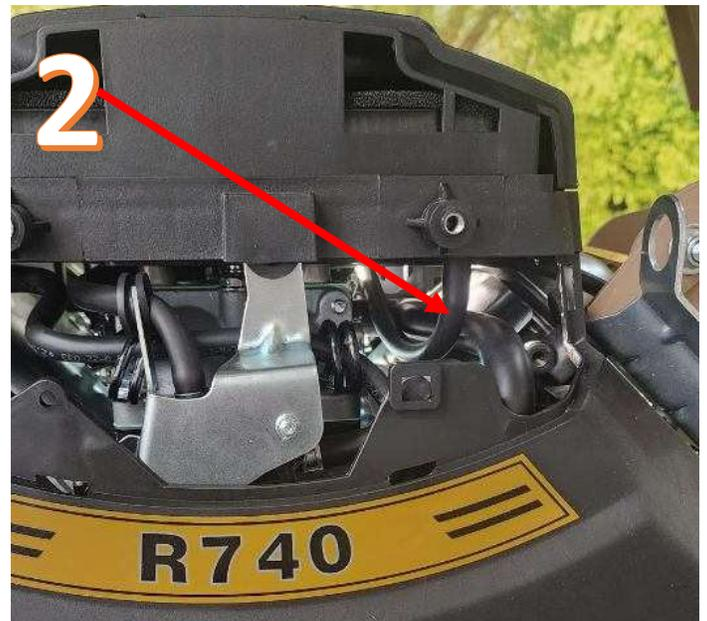

16B

INSTALL TANK TO THE ENGINE

1. **INSTALL TANK EVAP VALVE TOWARD THE **CHIP CHUTE** SIDE**
2. **CONNECT ALL 4 MOUNTING CORNERS AND TIGHTEN ALL BOLTS**
3. **ATTACH THE EVAP HOSE TO THE VALVE ON TOP OF THE TANK**
4. **INSTALL GAS LINE AND HOSE CLAMPS**
5. **TIGHTEN ALL TANK BRACKETS TO THE ENGINE TO SECURE THE TANK**

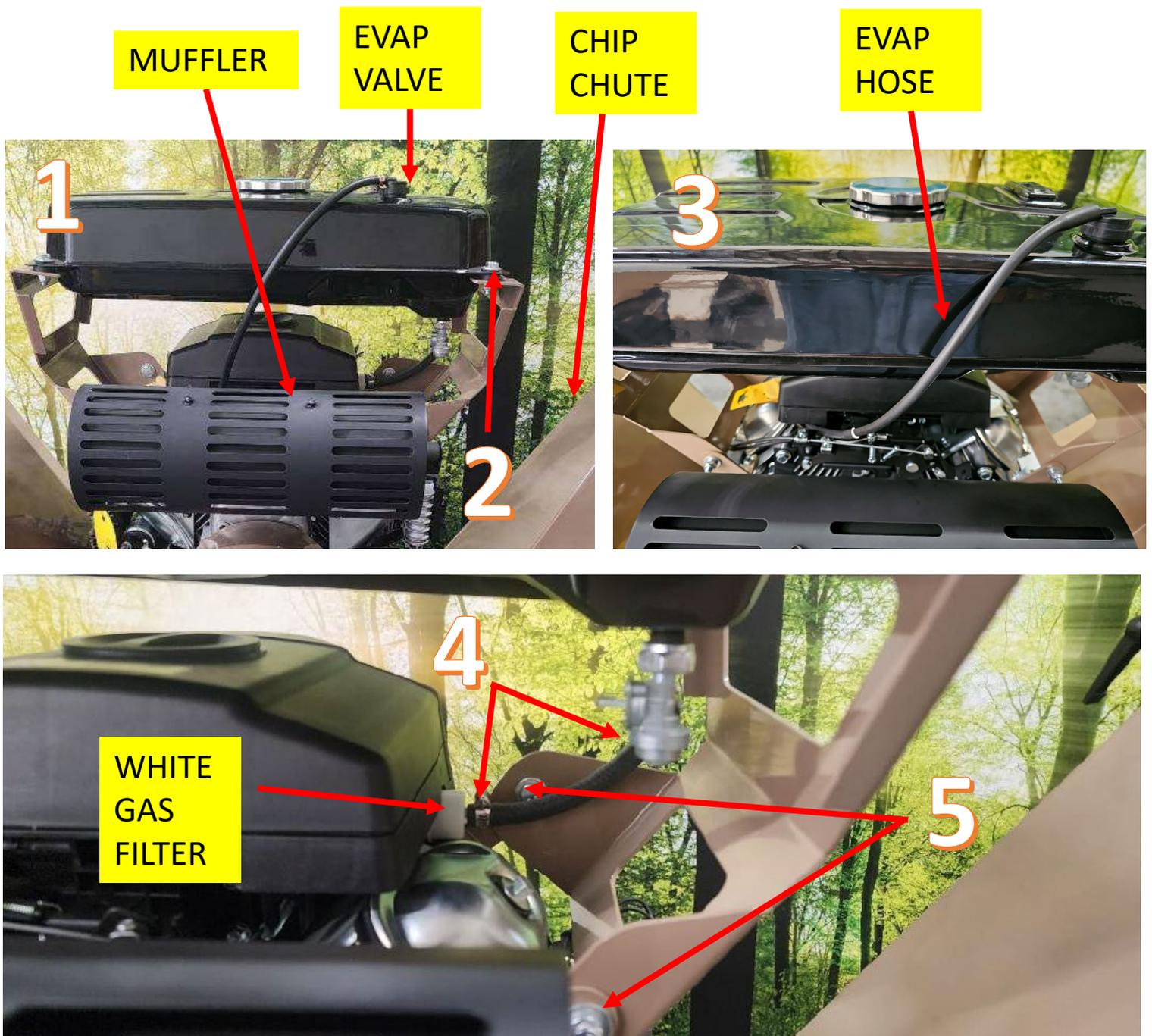

STEP 17

INSTALL SHUT OFF BAR

- 1. HANG BAR AS SHOWN**
- 2. ATTACH BROWN BAR TO ROADSIDE OF SILVER BAR**
- 3. TIGHTEN BOLT TO ALLOW MOVEMENT**
- 4. SWING UP BAR ATTACH TO LT SIDE – NYLON WASHERS AGAINST BAR**
- 5. ATTACH BAR TO RT SIDE – KEEP NYLON WASHERS AGAINST BAR**
- 6. TIGHTEN BOTH SIDES SNUG BUT ALLOW MOVEMENT OF BAR**
- 7. TEST THE BAR, PRESSING DOWN BAR SHOULD LOCK IN PLACE AND SILVER TRIP BAR WILL POINT DOWNWARD AFTER BAR INSTALLATION**

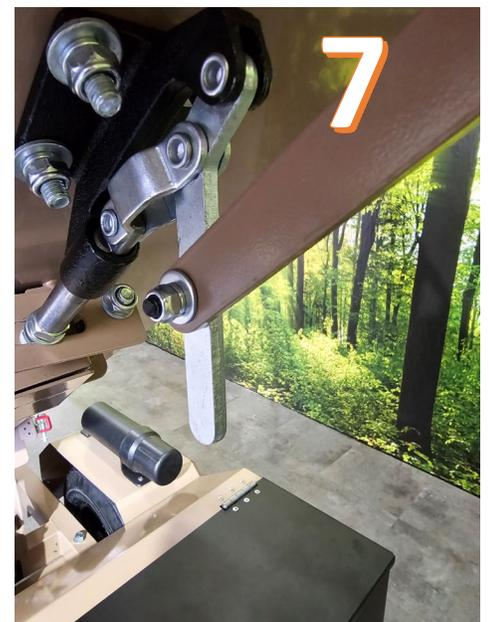
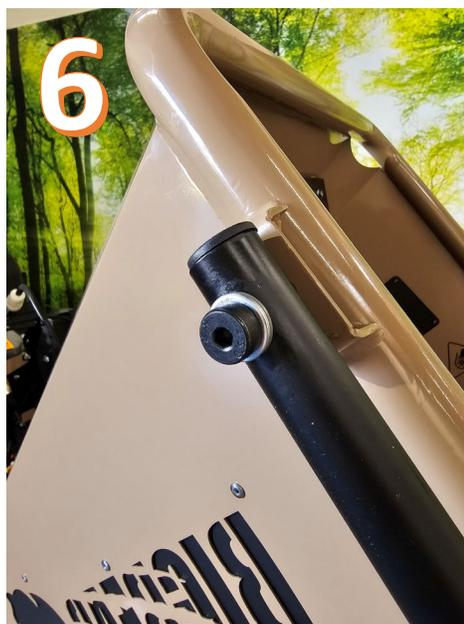

FINISH LINE

CONGRATULATIONS ON A GREAT JOB ASSEMBLING !

- 1. CHECK YOUR BOLTS ON YOUR CHIPPER BEFORE EACH USE**
- 2. CHECK YOUR OSHA COMPLIANT SAFETY SHUT OFF BAR BEFORE EACH OPERATION**
- 3. USE 10W-30 1.6L FOR YOUR ENGINE OIL API SERVICE LEVEL SJ**
- 4. CHECK YOUR OIL LEVEL ON LEVEL GROUND, REINSERT THE DIP STICK WITHOUT SCREWING IT IN TO CHECK THE OIL LEVEL. CHANGE YOUR OIL AFTER FIRST 20 HOURS. THEN EVERY 250 HOURS THEREAFTER.**
- 5. USE ONLY BIGBEAR OEM PARTS. ONLY BIGBEAR HIGH PERFORMANCE TORNADIC BLADES FIT BIGBEAR CHIPPERS. CALL 725-274-6171 FOR PARTS IN LAS VEGAS, NV.**
- 6. USE HIGH GRADE GASOLINE IN THIS TWIN CYLINDER ENGINE**
- 7. REPLACE YOUR BLADES AND DRIVE BELTS ONCE PER YEAR**
- 8. ALL DRUM BEARINGS AND WHEEL BEARINGS ARE PREPACKED AT FACTORY, GREASE ONCE PER YEAR WITH AXEL AND BEARING GREASE.**
- 9. FOLLOW YOUR MAINTENANCE SCHEDULE IN THE ENGINE MANUAL AND KEEP RECORDS**
- 10. THE INTENDED USE OF THIS CHIPPER IS TO CHIP TREES ONLY.**
- 11. TOW YOUR MACHINE AT 45MPH MAX AND SLOW TO 20MPH FOR TURNING**
- 12. FOLLOW ALL THE SAFETY RULES RECOMMENDED BY OSHA AND THE SAFETY WARNINGS ON THIS EQUIPMENT.**
- 13. DO NOT MODIFY THIS EQUIPMENT IN ANY WAY**
- 14. KEEP THOSE AROUND YOU A SAFE DISTANCE WHEN RUNNING THIS MACHINE**
- 15. DO NOT OPERATE THIS CHIPPER UNDER THE INFLUENCE OF MEDS DRUGS OR ALCOHOL**
- 16. WEAR PROTECTIVE SAFETY HEAD GEAR, LONG PANTS, WORK BOOTS, GLOVES**



BBC62 PARTS LIST

NO	Name	NO	Name	NO	Name
1	Upper discharge	58	Bolt M8X25	114	Insulated step mat
2	8 washer	59	Roller Puelly	115	Feed connection wire
3	Middle discharge	60	Belt cover inner plate	116	Mut M6
5	8 spring	61	Belt cover inner plate gasket	117	Plastic washr 10
6	Key 8*10*35	62	Nut M12	118	Logo cover plate
7	Blade	63	Bolt M8X16	119	In- feed
8	Quick bolt removal M8	64	Dust cap	120	Spring 12
9	Lower discharge	65	Slotted nut	121	Aluminium rivet 5
10	Bolt M8*245	66	Washer 26*45*3	122	Washer 12
11	Nut M10x1.5	67	Washer	123	Bearing seat cover
12	Washer 16	68	Tire16.5X6.5-8	124	Bolt M5X12
13	Front axle cover	69	Rear axle	125	Iron tie
14	Spring 10	70	Bearing FC207	126	Bolts M10*50
15	Spring 16	71	Drum shaft belt pulley side cover	127	Hour time
16	Front wheel main frame	72	Bolt M10X60	128	Bolt M8X20
17	Towing frame front frame	73	Lower coaming plate arc plate	129	Hour time fixation
18	Elastic bolt	74	Mut	130	Tank support retaining block
19	Spacer	75	Tire flange	131	Key6.3*6.3*50
20	Nut M16	76	Bolt M14*155	132	Engine pulley spacer
21	Bolt M10*170	77	Bolt M10X25	133	R740 Engine
22	Bearing	78	Nut14	134	Discharge rubber cushioning pad
23	Washer 10	79	Frame	135	Tank front securing plate
24	Bolt M10X80	80	Bolt M10X30	136	Fuel tank bracket lengthened fixing block
25	Pin wire B	81	Limit block stop Angle plate	137	Nozzle
26	Pin wire A	82	Spring14	138	Pressure reducing valve
27	Pin	83	Nut 8	139	Engine tank
28	Bolt M10X60	84	Battery box	140	Bolt M8X30
29	B Pin	85	Battery12V20ah	141	Bolt M12X25
30	Tower bar	86	Fender guard left	142	Plastic buckle
31	Front wheel bracket	87	Fender guard right	143	Drum
32	Bolt M5*15	88	Bolt M8X70	144	Pin 2.3X25
33	Chain	89	Battery platen	145	Bolt M8X45
34	Tower hitch	90	Lower blade	146	Pallet rack
35	Buckle	91	Battery pressurerubber	147	11 hinge
36	Tire 4.1-4	92	Tool cap	148	D Pin
37	Bolt M16X140	93	Drum shaft pull start side cover	149	Two hole pressure buckle hook
38	Bolt M5X16	94	Tool box	150	Tool box front plate
39	Fixing block on seat	95	Buckle 4001	151	Tool box cover
40	Bolt M16X160	96	Bolt M10*160	152	Bolt M10*30
41	Block holder (reverse)	97	Pressure spring 13 16 115	153	Lengthening nut
42	Front wheel outer spacer	98	Emergency stop switch limit plate	154	Bolt M4*12
43	Spring retaining sleeve	99	Quick clip drive arm	155	M4 Washer
44	Bolt M8X40	100	Spring 6	156	4 apring
45	Stuck block	101	Quick clip	157	Bolt M14*130
46	Card block fixing seat	102	Bolt M8*25	158	Pin 2.9X36
47	Nut M5	103	Emergency stop switch tube	159	Tank back securing plate
48	D Pin	104	Feed inlet rubber baffle strip	160	Engine pulley
49	Fixing block on seat	105	Feed inlet rubber damper	161	Bolt M10*40
50	Bolt M6X12	106	Bolt M14*145	162	Guide cover welded body
51	Flat Washer 10 40 3	107	Bolt M10*30	163	Gasoline engine panel
52	Belt cover	108	Bolt M8*12	164	Hoop
53	Belt cover word cap	109	Latch hanger ring	165	Gasoline pipe
54	Flat washer 8*40*3	110	BBC Letter plate	166	Evaporating pipe
55	Washer M8	111	Bolt M6*70	167	Bolt
56	Belt B-1168	112	Washer M6	168	Engine spacer
57	Extension spring	113	Contact cover plate	169	Bolt M8*90

BBC62 PARTS DRAWING

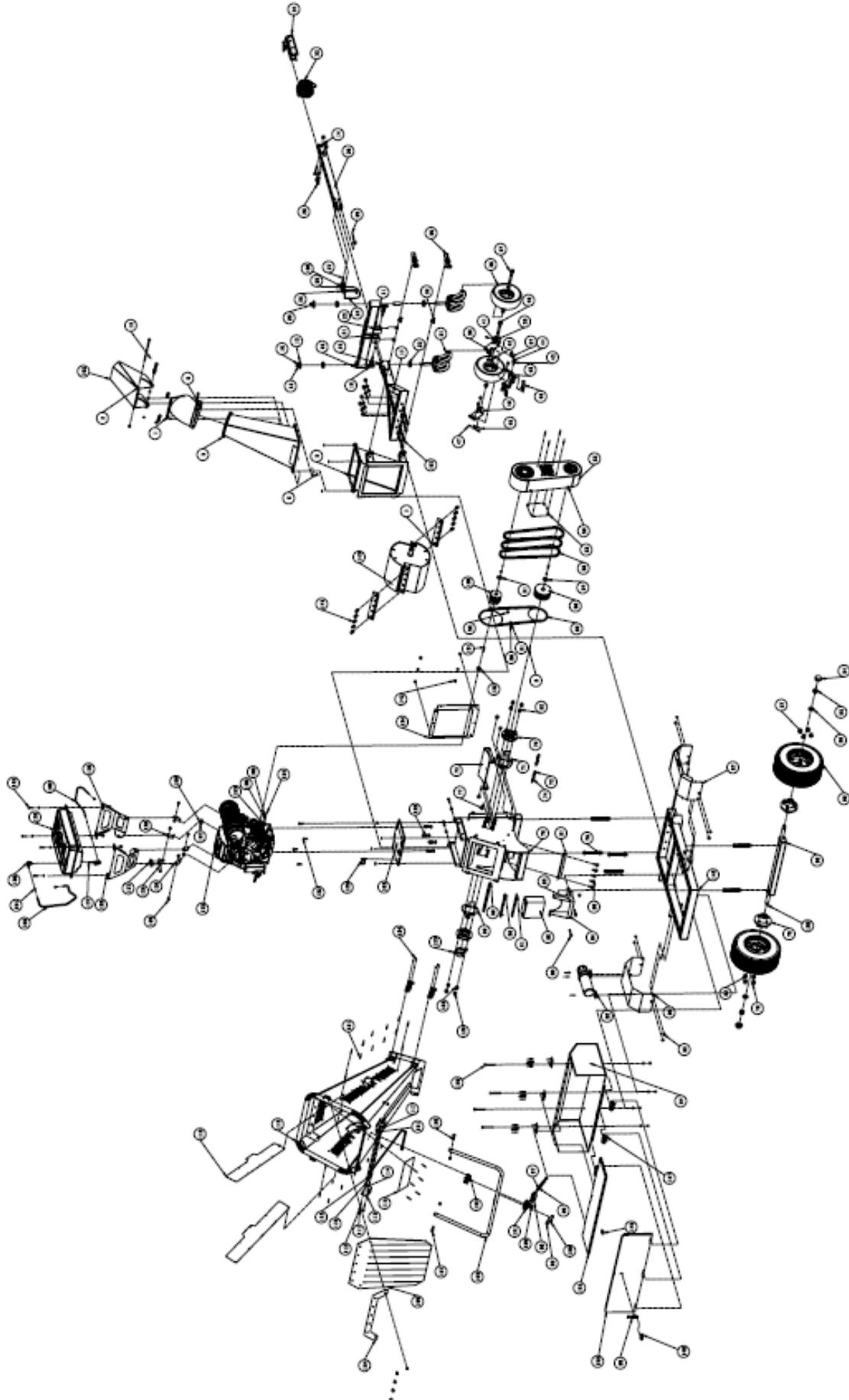

BBC62 PARTS DRAWING

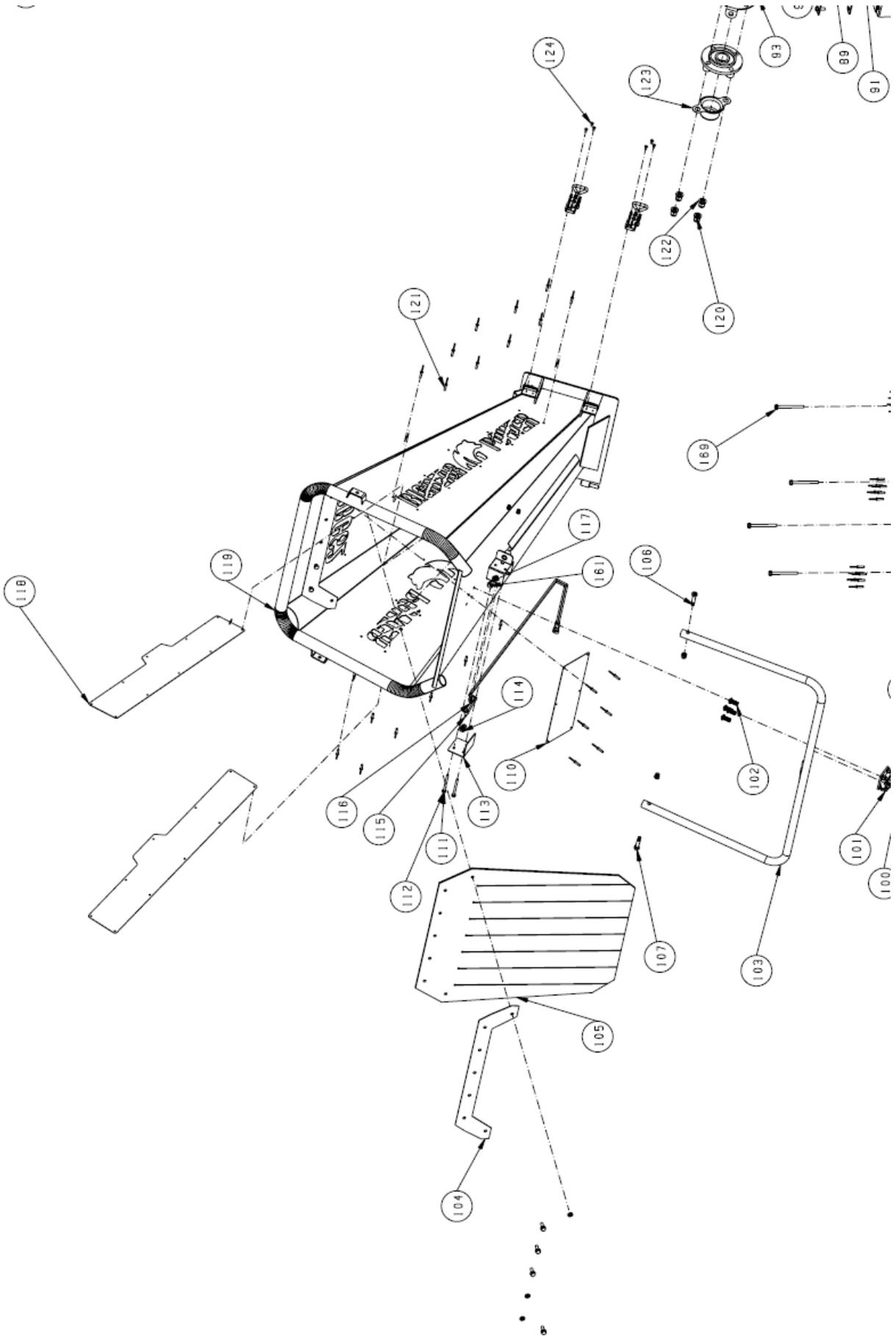

BBC62 PARTS DRAWING

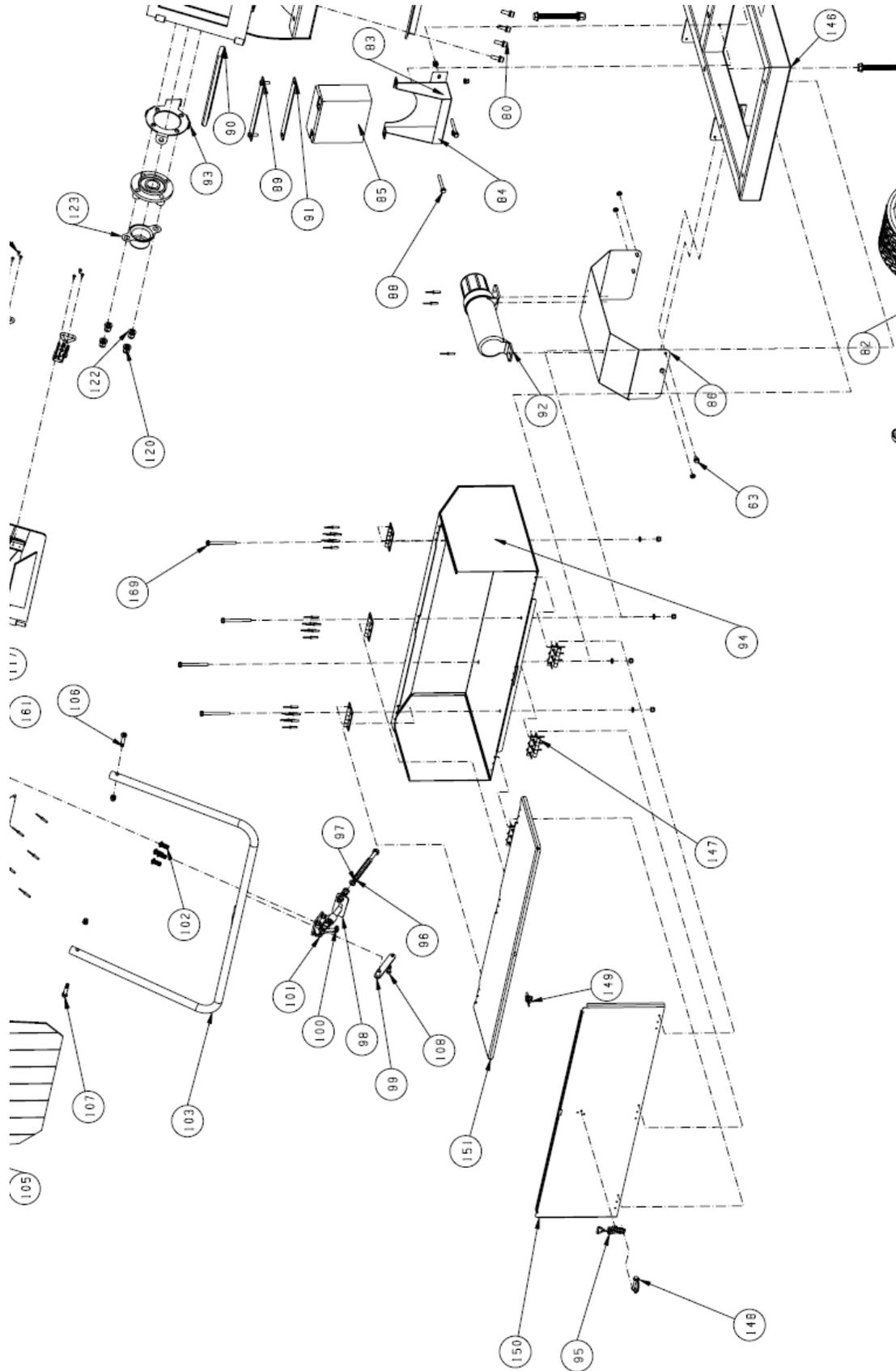

BBC62 PARTS DRAWING

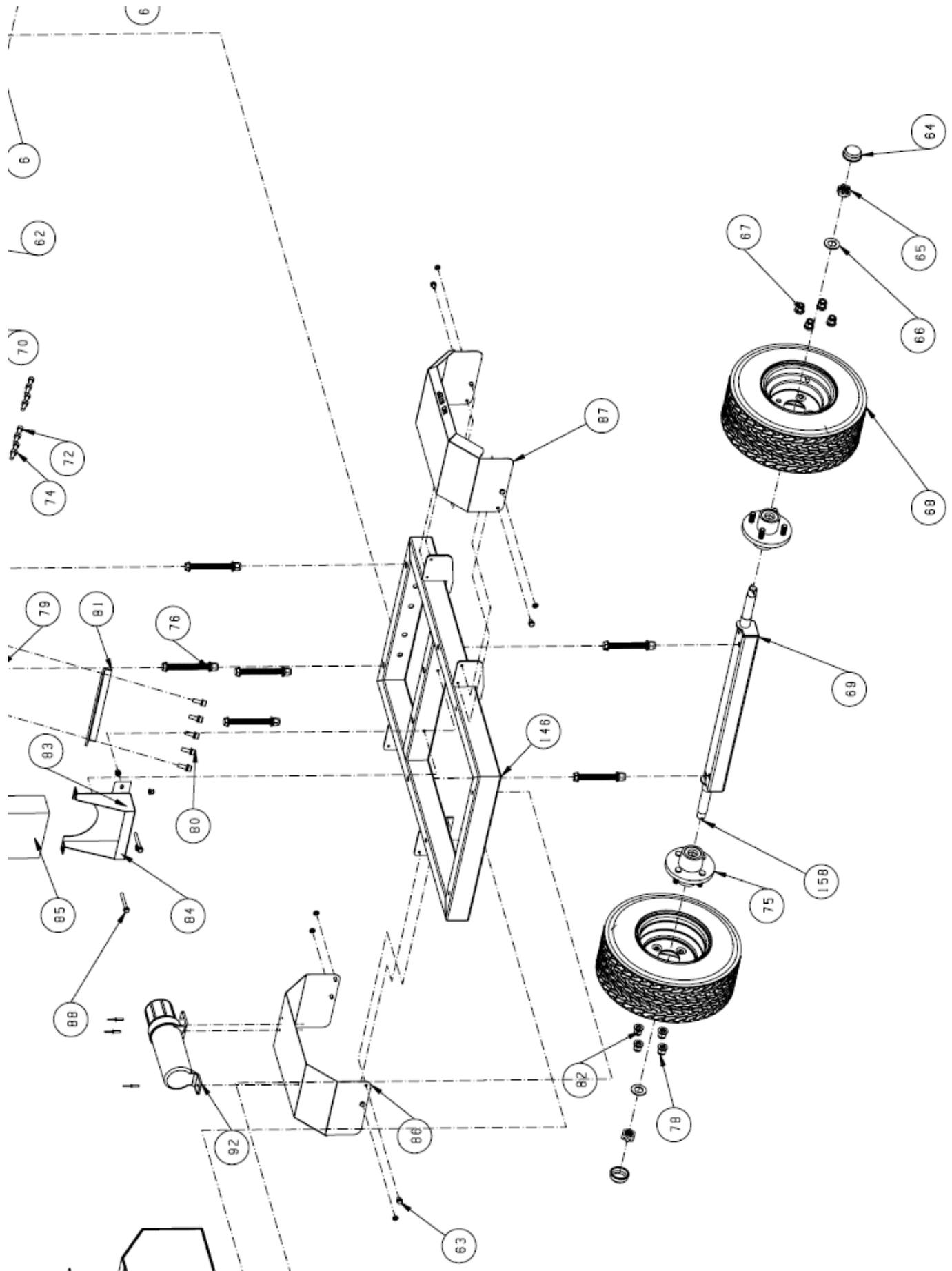

BBC62 PARTS DRAWING

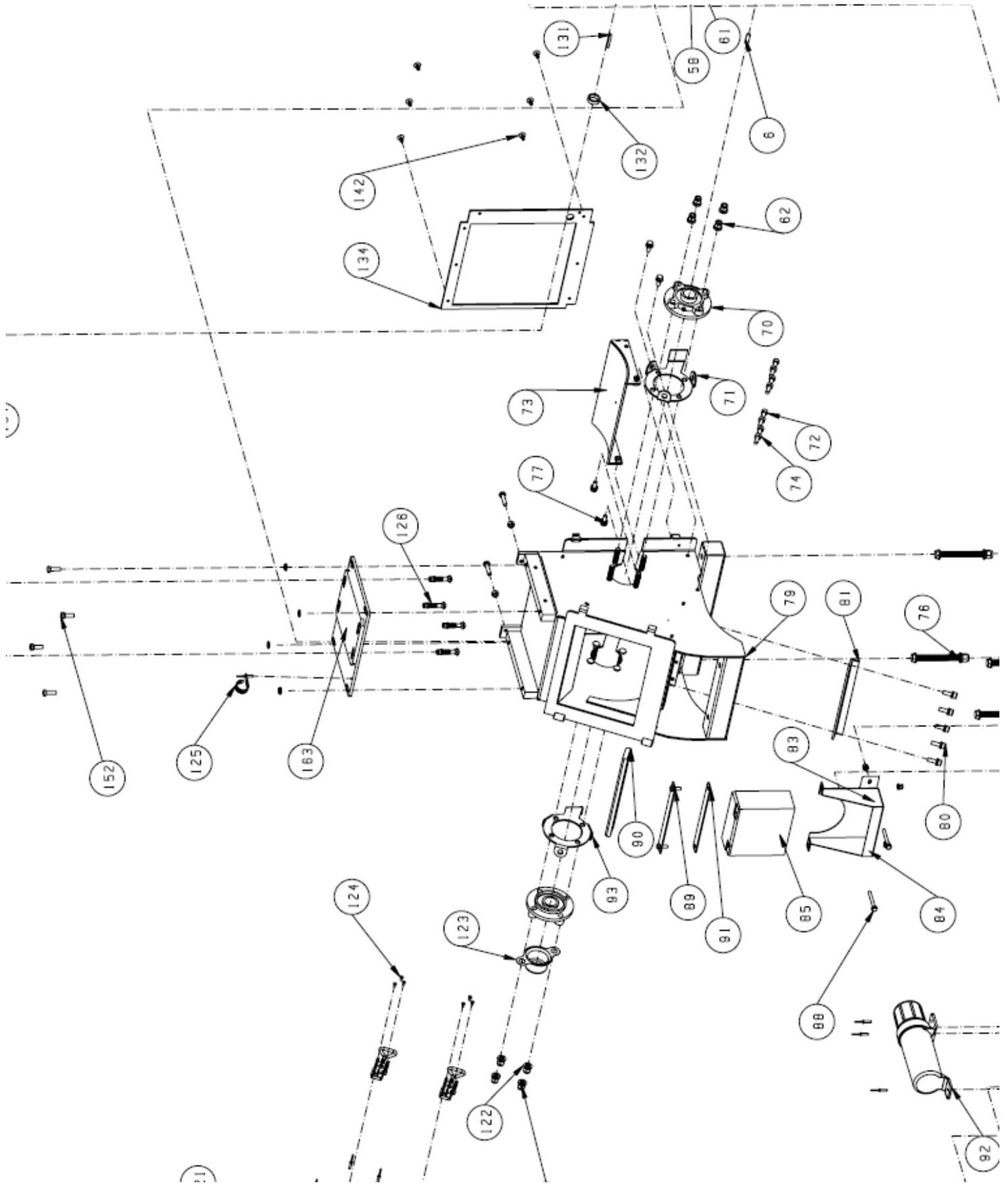

BBC62 PARTS DRAWING

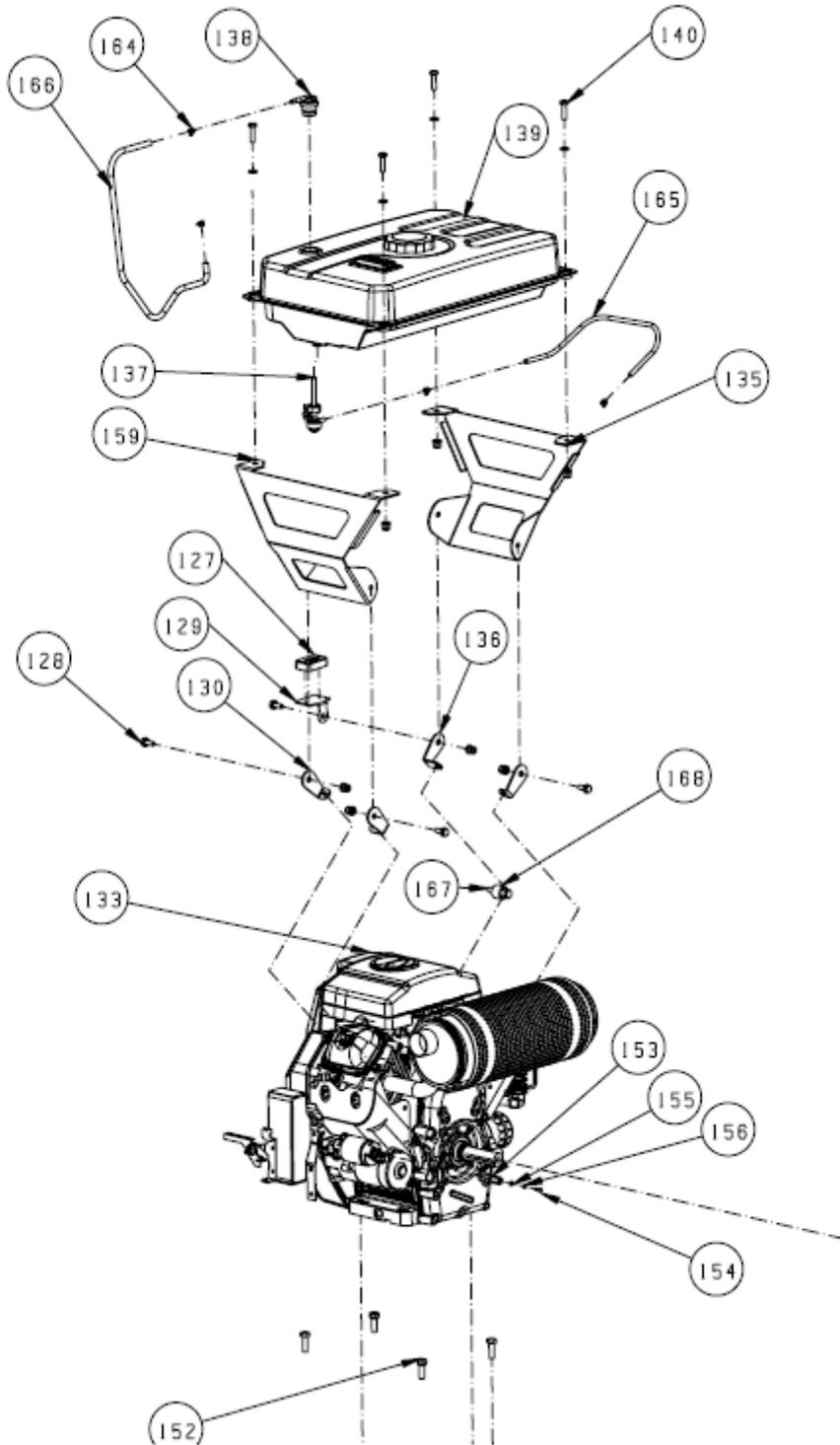

BBC62 PARTS DRAWING

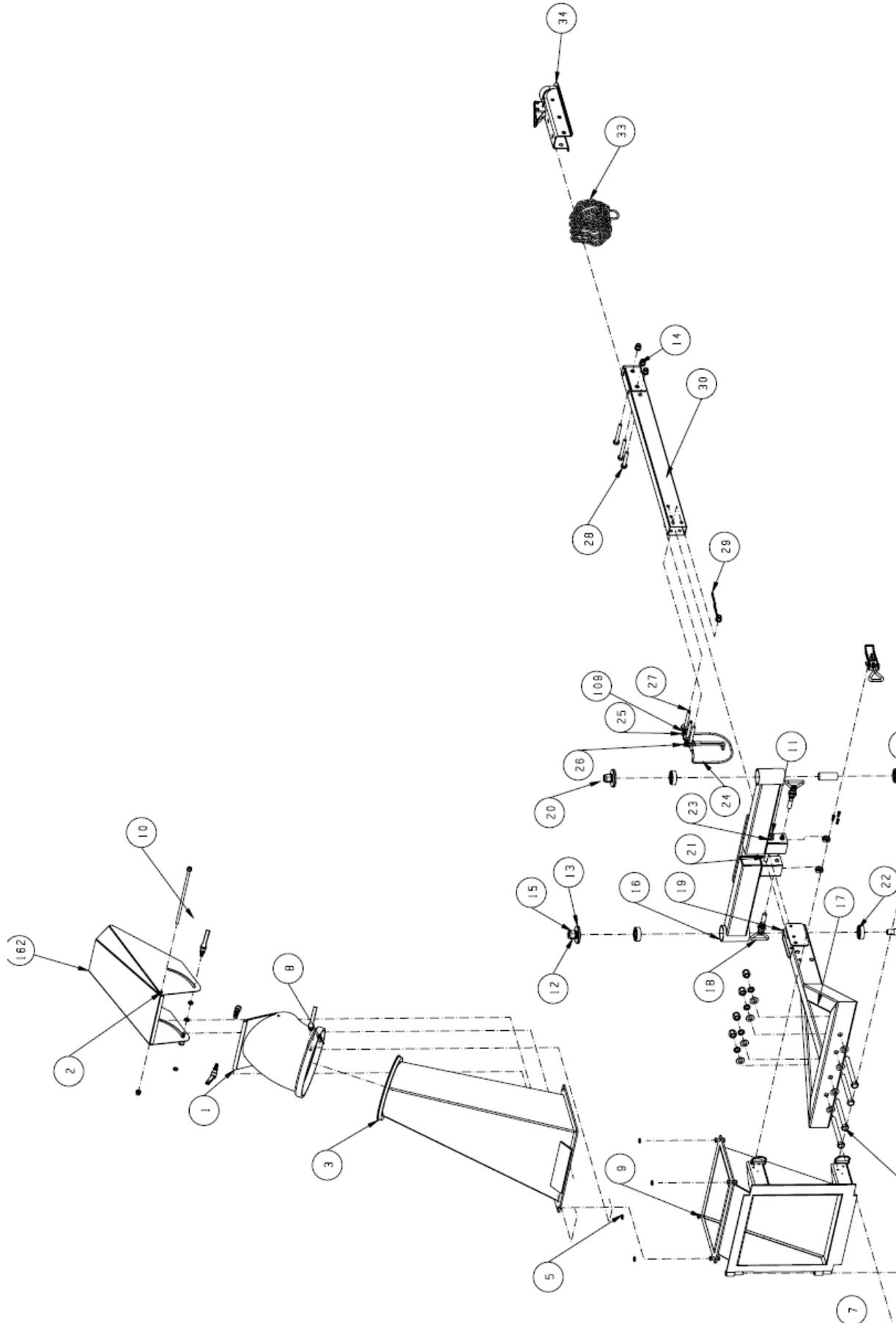

BBC62 PARTS DRAWING

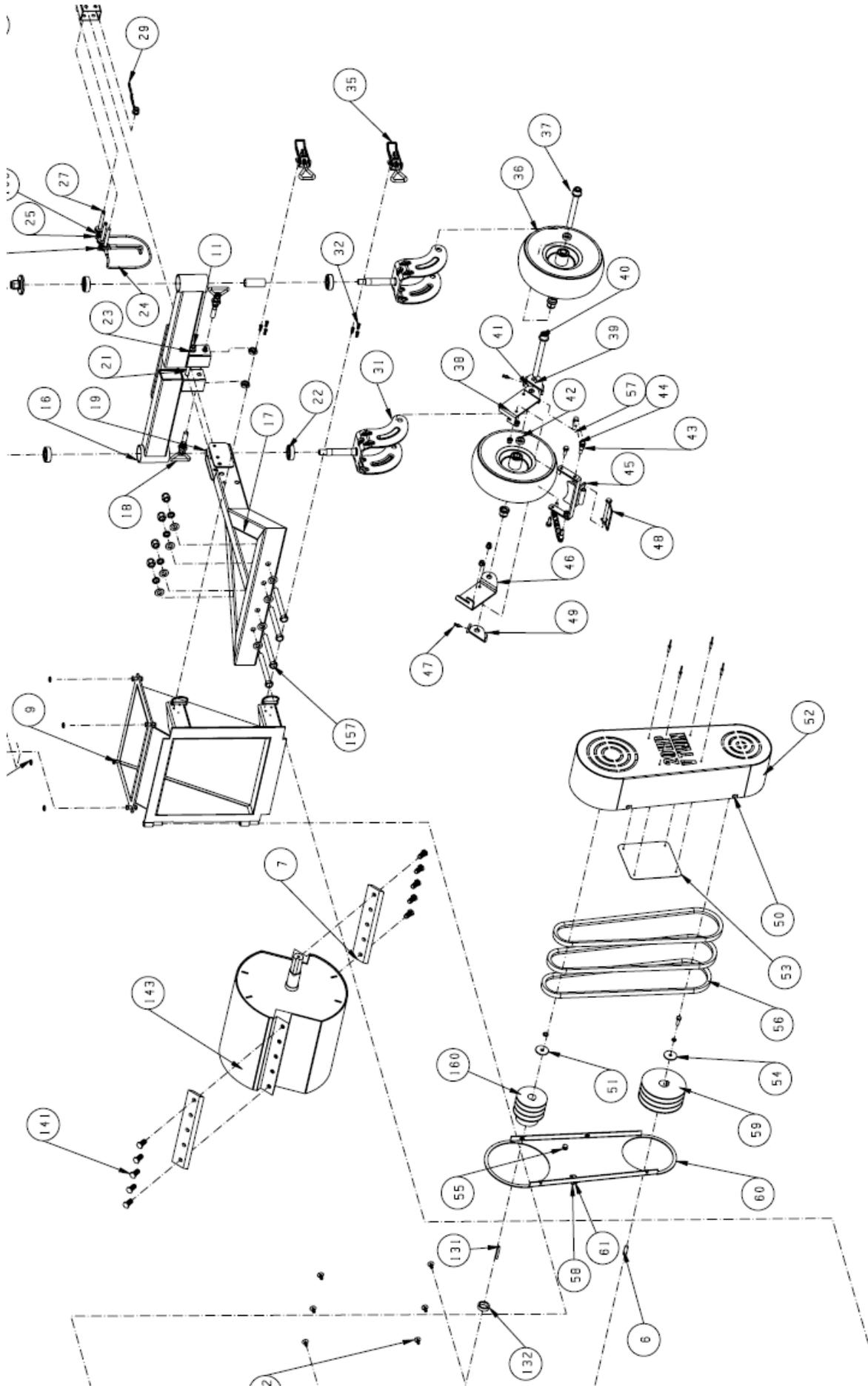



BIG BEAR POWER

**GX COMMERCIAL LLC
4301 S VALLEY VIEW BLVD. STE 10 AND 11
LAS VEGAS, NV 89103**

EXTENDED 5YR LIMITED WARRANTY

- GX COMMERCIAL LLC WARRANTS THIS WOODCHIPPER FOR MANUFACTURES DEFECTS FOR 5 YEARS BOTH ENGINE AND CHASSIS AS FOLLOWS.
- GX COMMERCIAL LLC WILL PROVIDE PARTS AND LABOR WITHIN THE FIRST 30 DAYS AT NO COST TO THE ORIGINAL PURCHASER. GX COMMERCIAL LLC WILL REPAIR OR REPLACE AT OUR OPTION THE DEFECTIVE EQUIPMENT.
- AFTER 30 DAYS GX COMMERCIAL LLC WILL PROVIDE TO THE ORIGINAL PURCHASER FOR 5 YEARS REPLACEMENT PARTS FOR DEFECTIVE PARTS INCLUDING ENGINE AND ALL CHASSIS COMPONENTS.
- ITEMS NOT COVERED BY THIS WARRANTY AFTER 30 DAYS ARE REPAIR LABOR, BLADES, BELTS, TIRES, CUTTING BARS, NUTS AND BOLT HARDWARE AND BATTERIES.
- CUSTOMER ACCEPTED FREIGHT DAMAGE IS NOT COVERED BY WARRANTY.
- MINOR SCRATCH AND DENTS FROM SHIPPING IS NOT COVERED.
- RATO ENGINES ARE 1 YEAR WARRANTY, A 4 YEAR OEM COMMERCIAL EXTENDED WARRANTY IS INCLUDED AT NO EXTRA COST. GX COMMERCIAL LLC WILL REPAIR OR REPLACE RATO ENGINES AT OUR CHOICE FROM 5 YEARS FROM PURCHASE DATE. WARRANTY NOT TRANFERABLE.
- THIS EXTENDED WARRANTY APPLIES TO BOTH RESIDENTIAL AND COMMERCIAL USE OF THE EQUIPMENTS BASED ON PROPER MAINTENACE AND RECORDS OF PROVEN REGULAR SCHEDULED OIL CHANGES, FILTERS AND SPARK PLUG MAINTENACE. NON-INTENDED USE OR MISUSE OF EQUIPMENT IS NOT COVERED.
- DEFECTIVE EQUIPMENT UNDER WARRANTY IS REQUIRED TO BE REPAIRED BY A LICENCED MECHANIC. PARTS WILL BE SENT TO THE REPAIR SHOP OF THE CUSTOMERS CHOICE AT NO COST DURING THE WARRANTY PERIOD.