

6905-11988 Convertible Garment Rack

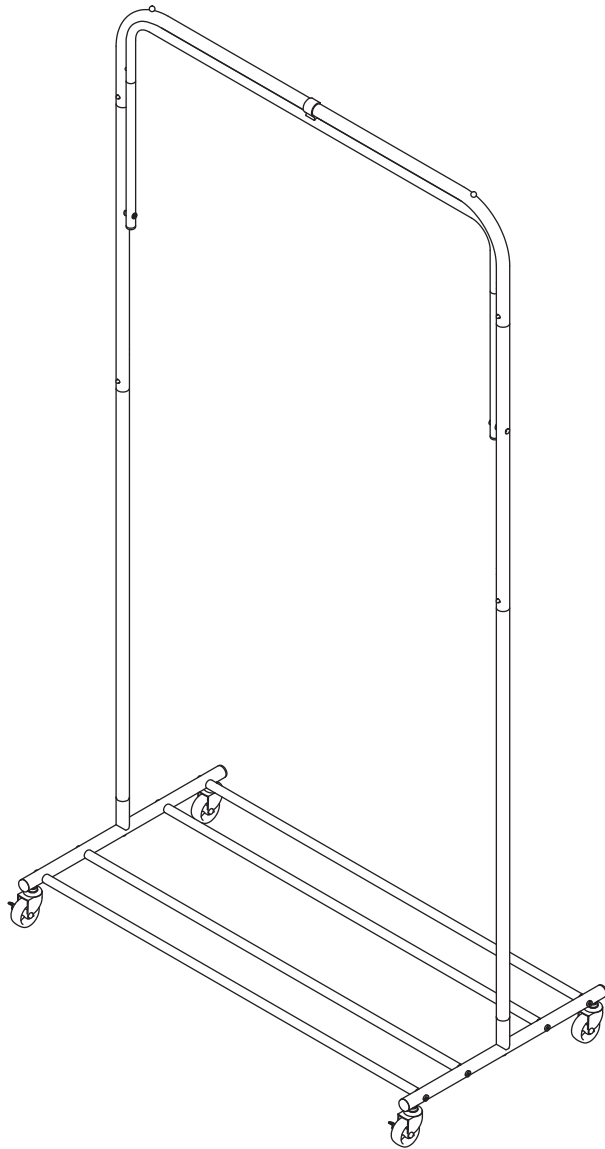

Part	Reference
A	F11253
B	F11254
C	F11255
D	F11256
E	F11257
F	F11258
G	F11259
H	F11260
I	F11261
J	F11262
K	F11263
L	F11264
M	F11283
N	F11120

No additional tools required.

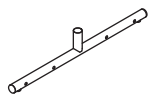

A 2 ea
Base Frames

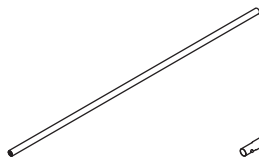

B 4 ea
Base Tubes

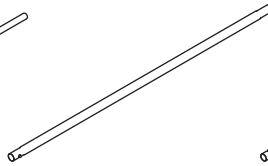

C 2 ea
Lower Vertical Tubes

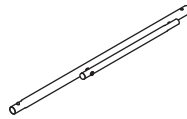

D 1 ea
Right Upper Vertical Tube

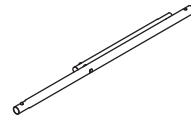

E 1 ea
Left Upper Vertical Tube

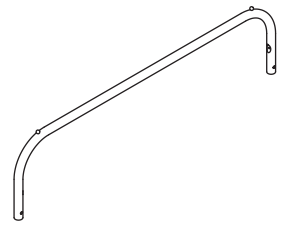

F 1 ea
Large Hanging Bar

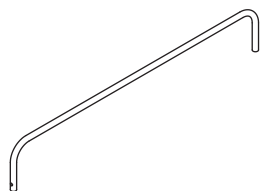

G 1 ea
Small Hanging Bar



H 2 ea
Wheels



I 2 ea
Locking Wheels



J 2 ea
Long Hex Screws



K 8 ea
Short Hex Screws



L 1 ea
Locking Clip



M 1 ea
Hex Wrench



N 1 ea
Wrench

STEP 1:

- Attach the four base tubes (B) to the two base frames (A) using eight short hex screws (K). Tighten with a hex wrench (M).

NOTE: Make sure the base tube connectors are facing up.

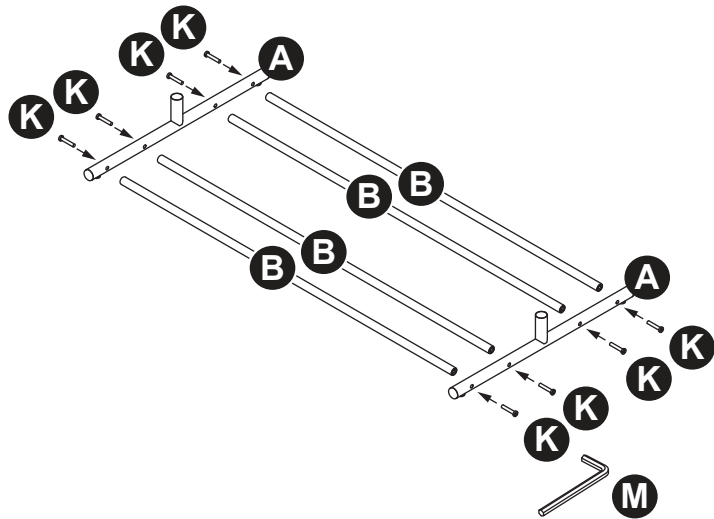

STEP 2:

- Attach two lower vertical tubes (C) into base frames (A) using two long hex screws (J). Hand tighten.

NOTE: Make sure the push pins are facing forward.

- Insert upper vertical tubes (E & D) onto lower vertical tubes (C).

- Make sure the push pins click into place.

- Tighten the two long hex screws (J) with the hex wrench (M).

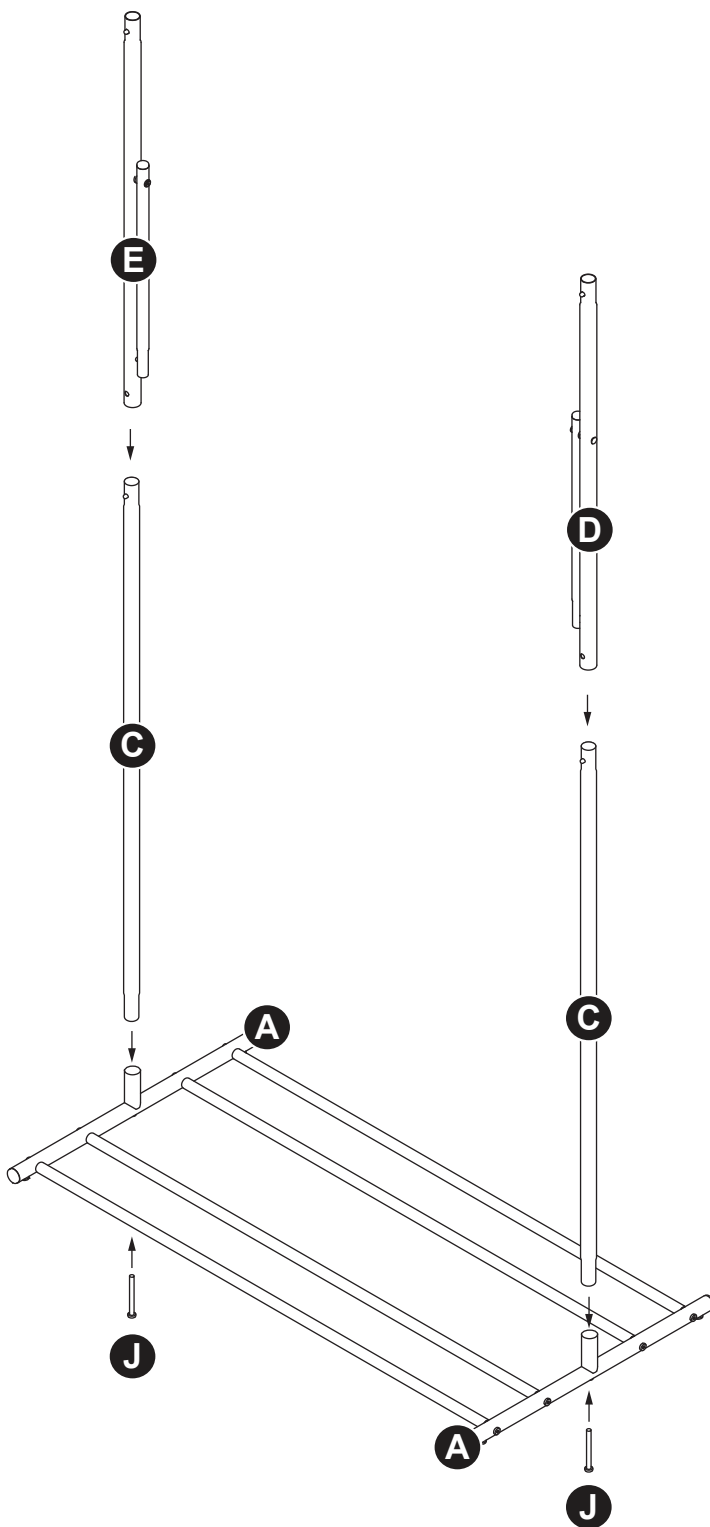

STEP 3:

- Insert small hanging bar (**G**) onto upper vertical tubes (**E & D**).
- Make sure the push pins click into place.

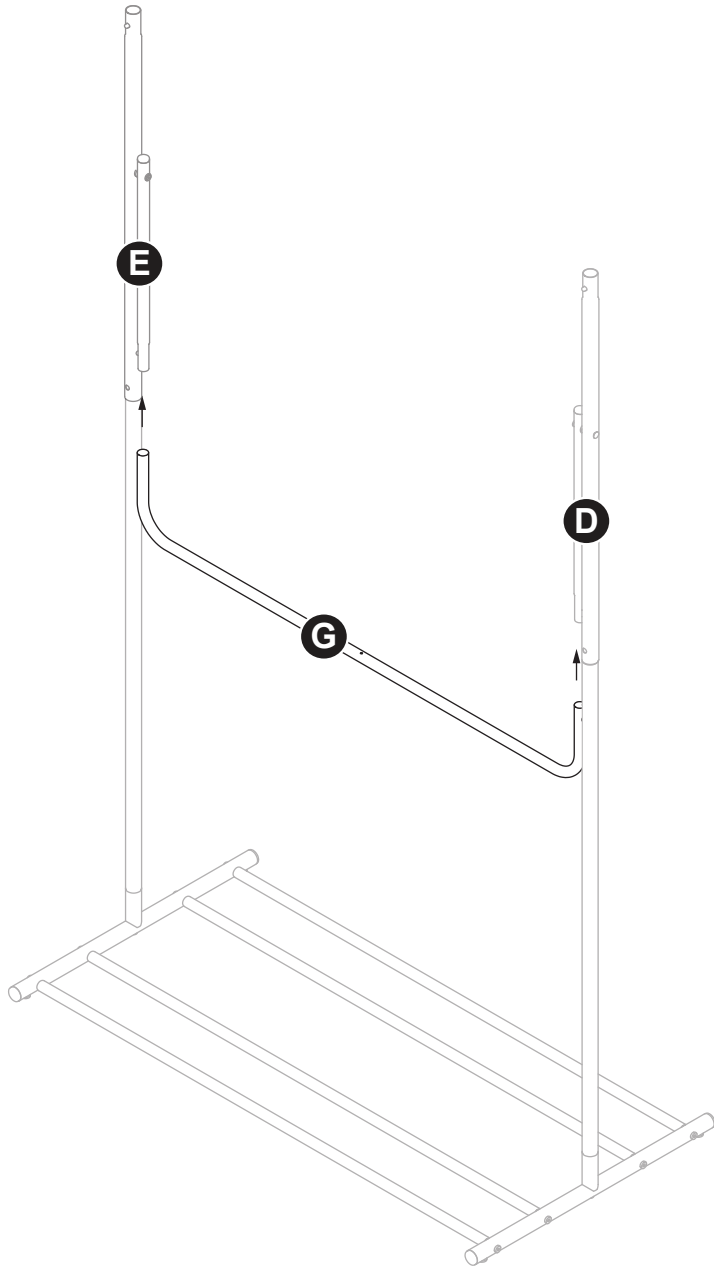

STEP 4:

- Insert large hanging bar (**F**) onto upper vertical tubes (**E & D**).
- Make sure the push pins click into place.

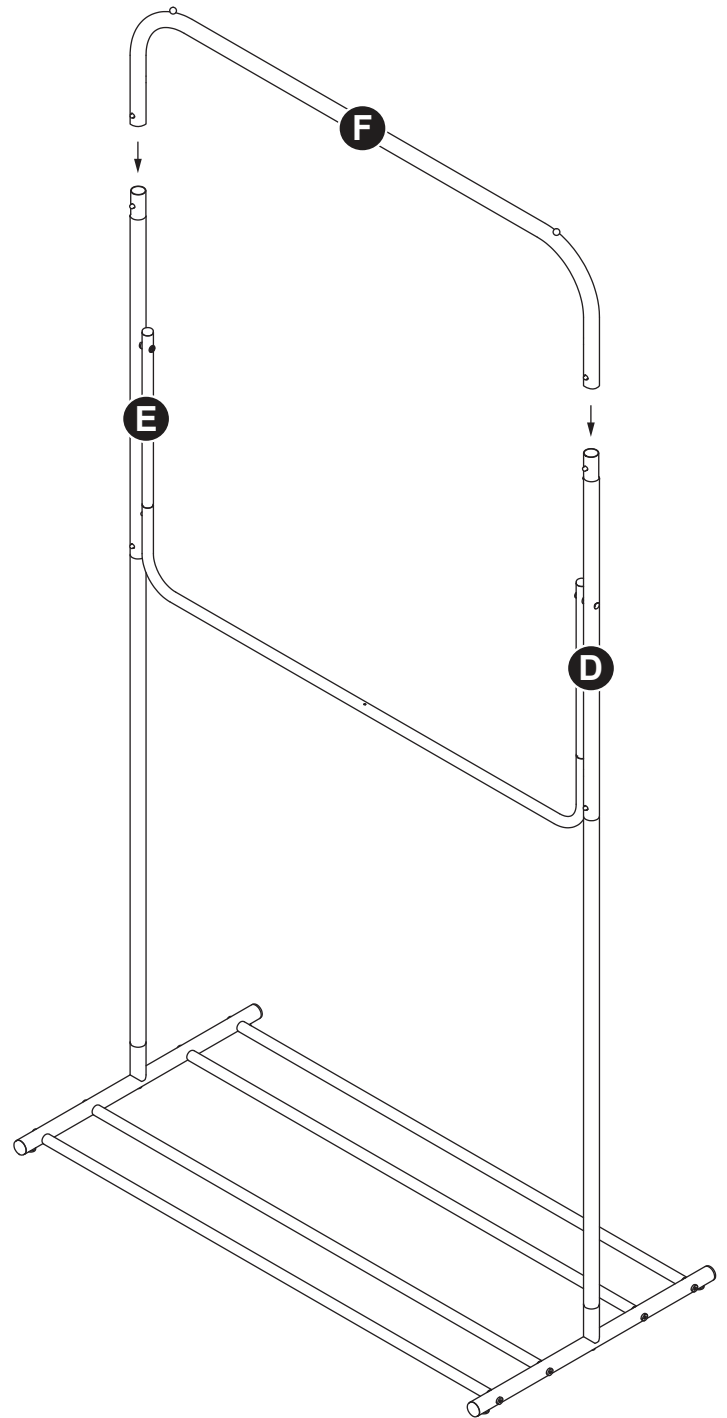

STEP 5:

- Attach two locking wheels (I) on one side and two wheels (H) on the other side. Use the wrench (N) to tighten.
- Attach locking clip (L) onto the large hanging bar (F).
- Make sure the push pins click into place.

NOTE: Small bar can be used as a second rod for shorter garments or locked onto the large hanging bar for longer garments.

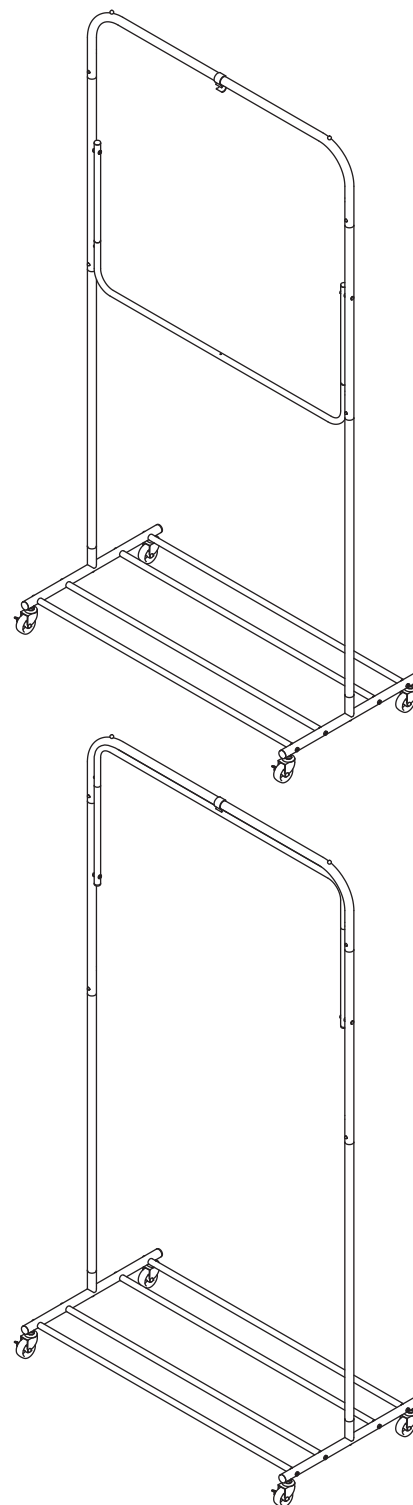
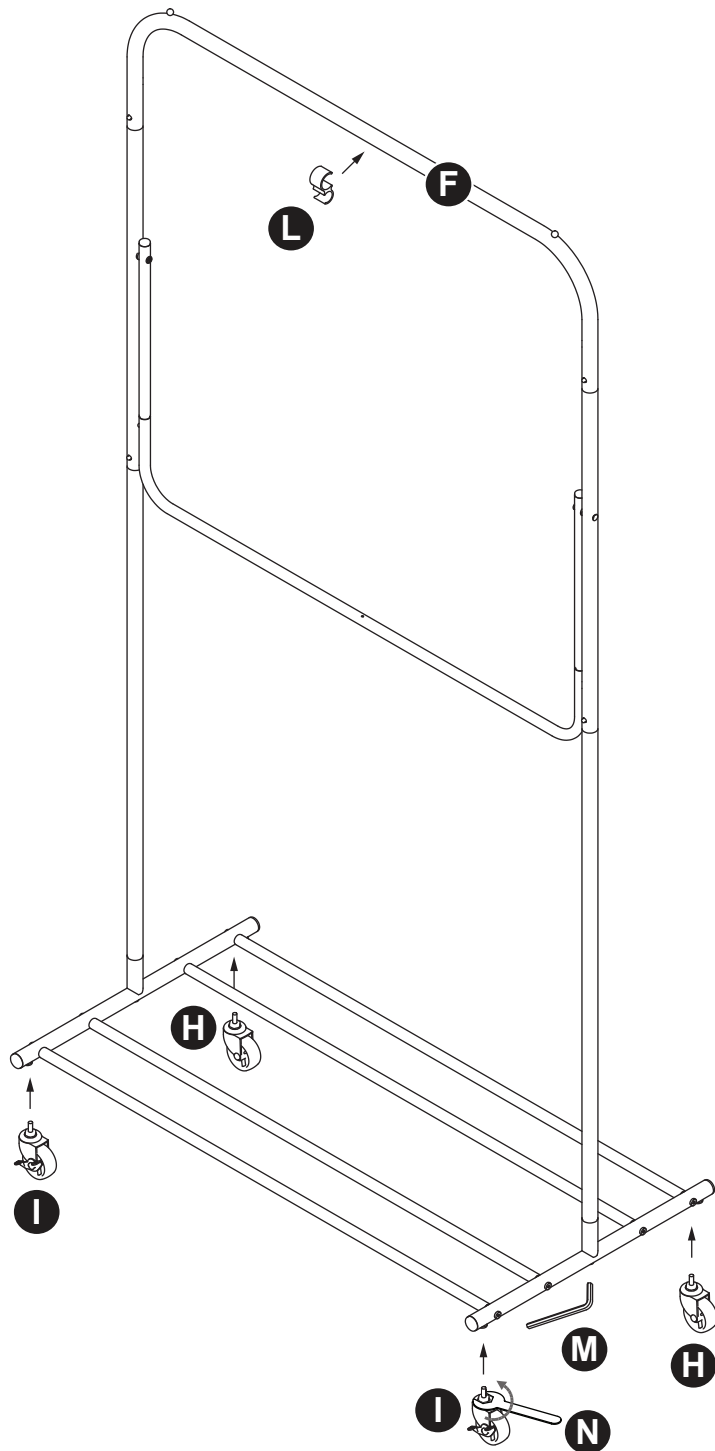

8680 Swinnea Road • Suite 103 • Southaven, MS • 38671

NEED HELP? For help with assembly, or if you are missing a part, please call Whitmor's Consumer Care Team, 1-888-944-8667 between 8 a.m. and 4:30 p.m. (Central Standard Time) Monday through Friday, or email: help@whitmor.com. Visit us online at www.whitmor.com