

Part	Reference
A	F11965
B	F11966
C	F11967
D	F11968
E	F11969
F	F11970
G	F11971
H	F11972
I	F11973
J	F11974

No additional tools required.

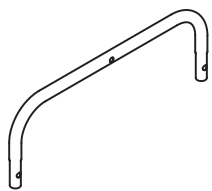

A 2 ea
Top Tubes

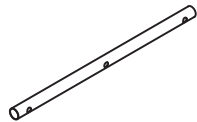

C 4 ea
Top Poles

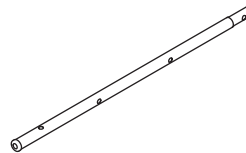

E 4 ea
Bottom Poles

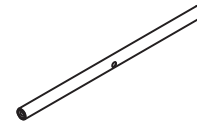

G 2 ea
Bottom Supports

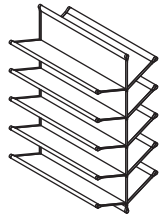

I 1 ea
Mesh Shelves

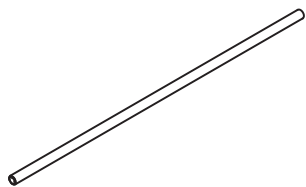

B 12 ea
Horizontal Shelf Tubes



D 2 ea
Wheels

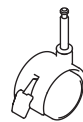

F 2 ea
Locking Wheels



H 28 ea
Hex Screws

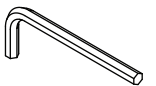

J 1 ea
Hex Wrench

STEP 1:

- Start by assembling the side frames.
- Insert ends of the top tube (A) into two top poles (C).
- Insert top poles (C) into ends of bottom poles (E).
- Install the bottom support (G) between the bottom poles (E) using the lowest holes available. **NOTE:** make sure the hole in the middle of bottom support (G) is facing up like the rest of the holes in the frame.
- Secure using a hex wrench (J) and two hex screws (H).
- Repeat this step to assemble the other side frame.

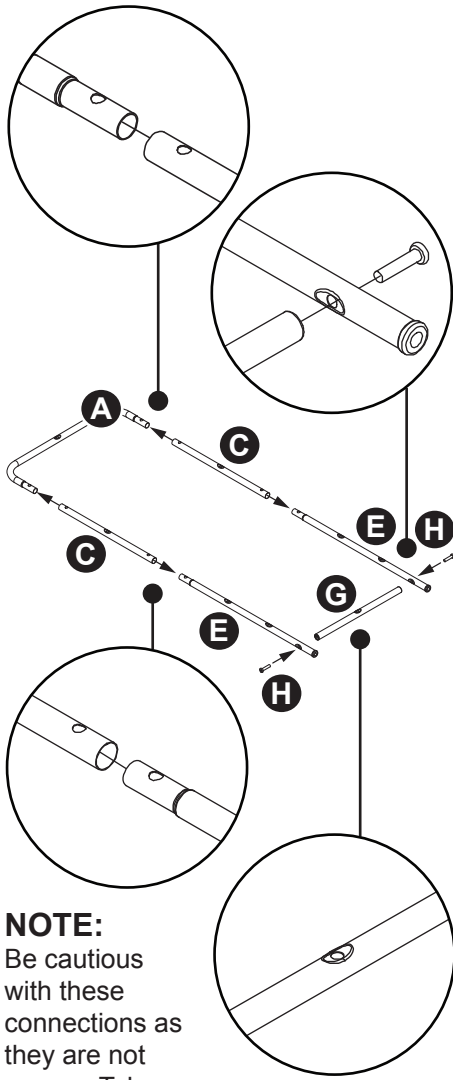

NOTE: Be cautious with these connections as they are not secure. Take necessary precautions until they are secured.

NOTE: Center holes on bottom supports (G) must face each other.

STEP 2:

- Insert ends of the horizontal shelf tubes (B) into top tube (A) and bottom support (G).
- Secure using a hex wrench (J) and two hex screws (H).

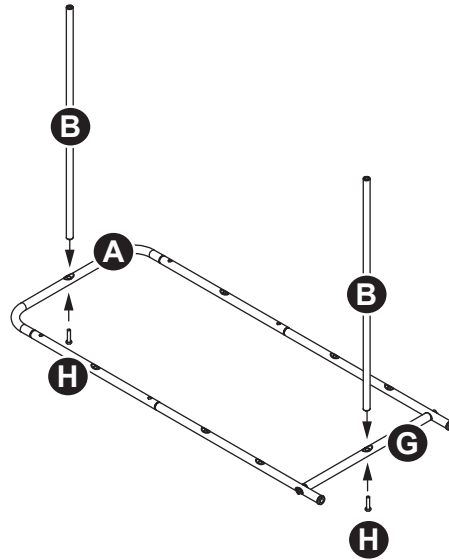

STEP 3:

- Insert mesh shelves (I) onto the horizontal shelf tubes (B). As shown below.

NOTE: Make sure the tag is at the bottom of mesh shelves.

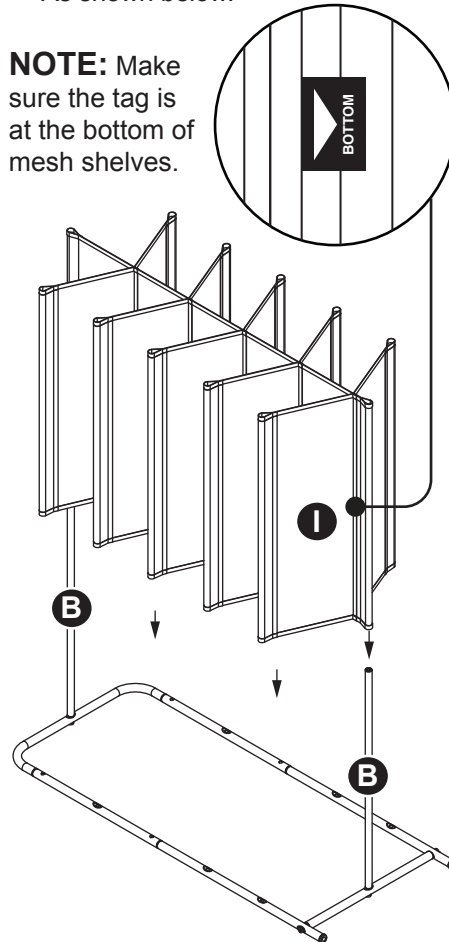

STEP 4:

- Insert four horizontal shelf tubes (B) into mesh shelves (I).
- Secure using a hex wrench (J) and four hex screws (H).

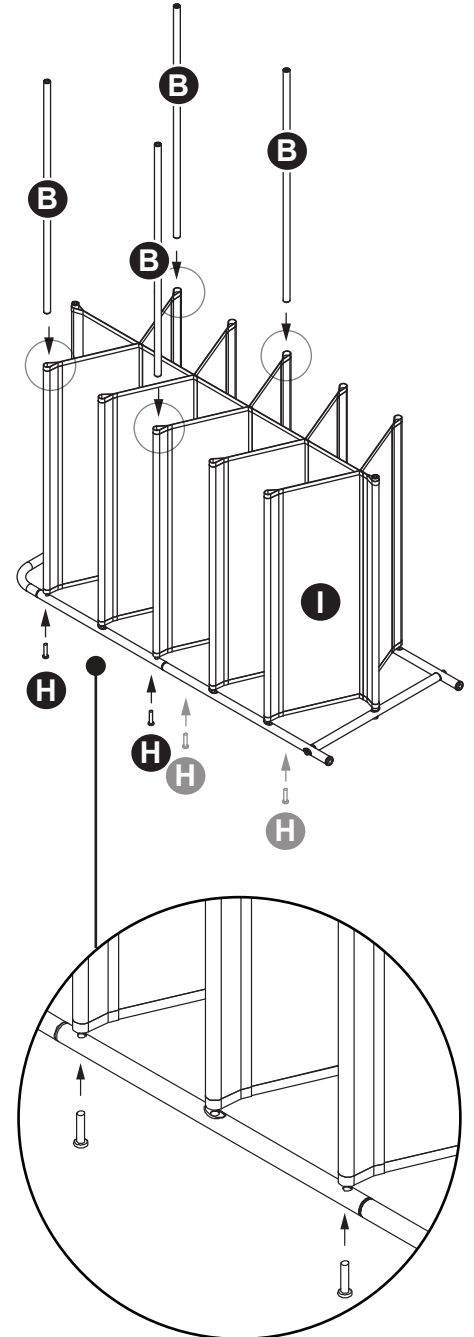

NOTE: The previously unsecured connections have now been secured, making it easier to handle the item.

STEP 5:

- Insert six horizontal shelf tubes (B) into mesh shelves (I).
- Secure using a hex wrench (J) and six hex screws (H).

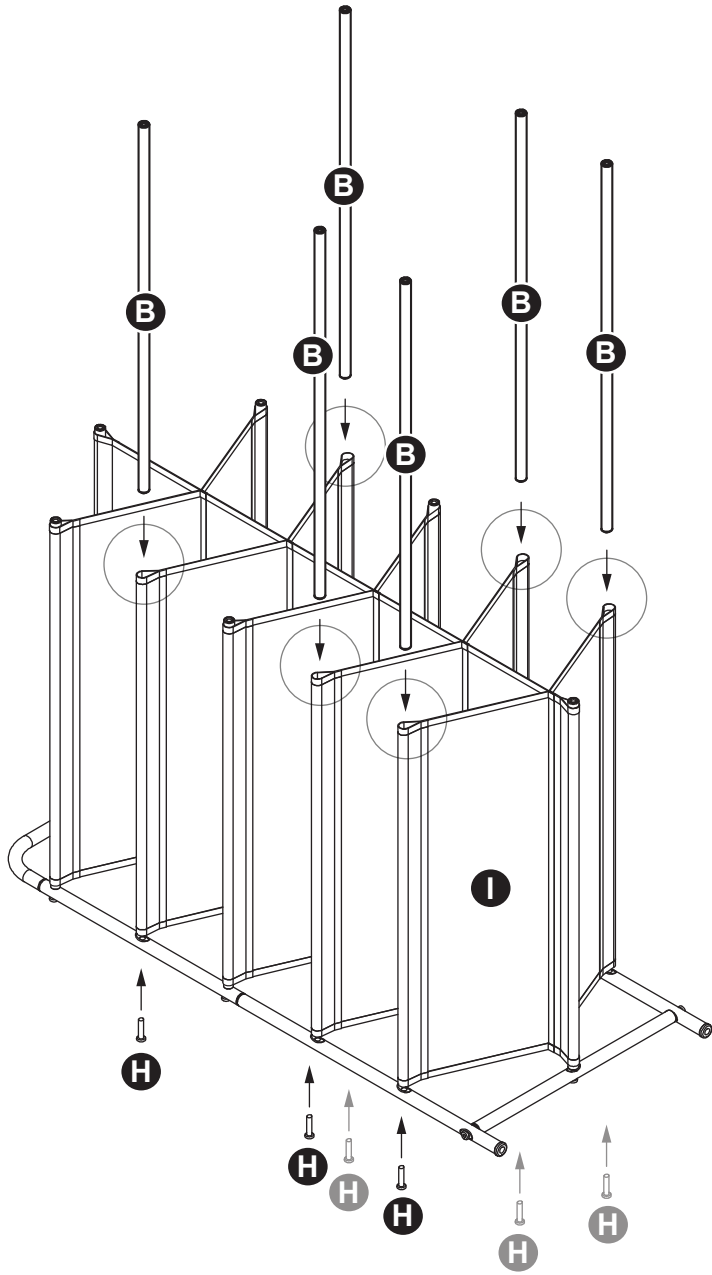

STEP 6:

- Connect the side frame to the top and bottom horizontal shelf tubes (B) using two hex screws (H).

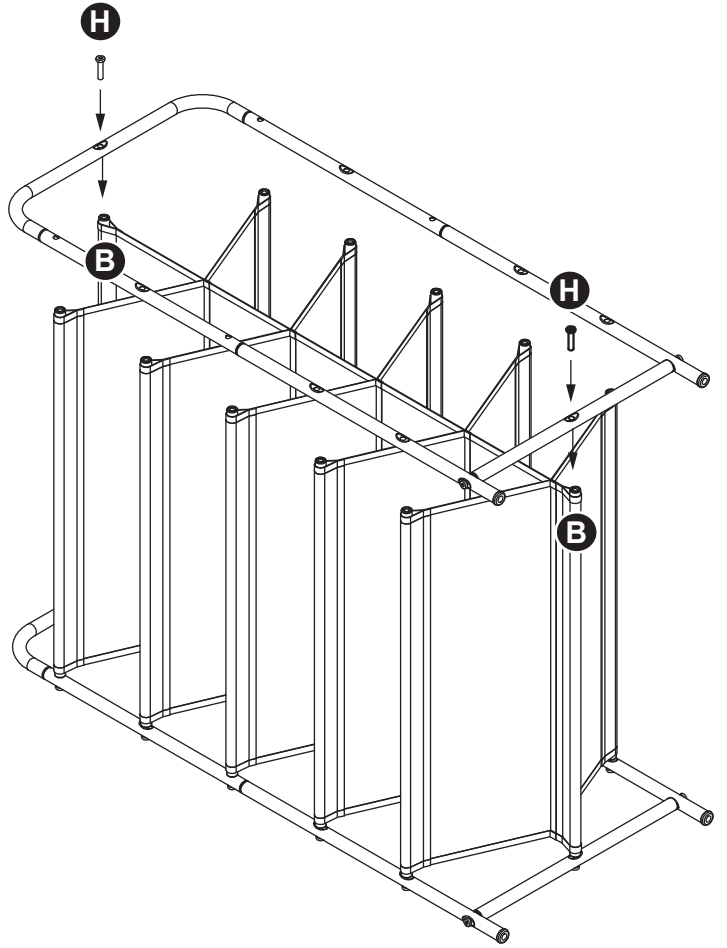

NOTE: Push down the mesh shelves as shown below to make it easier to connect the side frame to the horizontal shelf tubes (B).

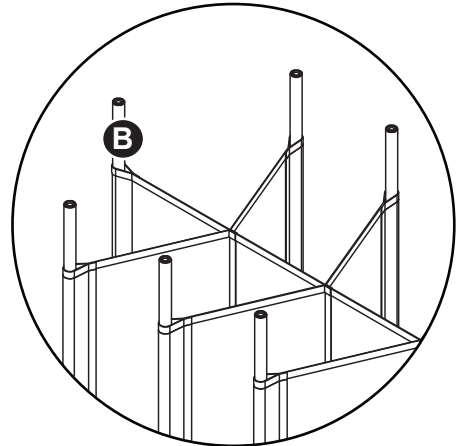

STEP 7:

- Secure the side frame to the remaining horizontal shelf tubes (B) using twelve hex screws (H).

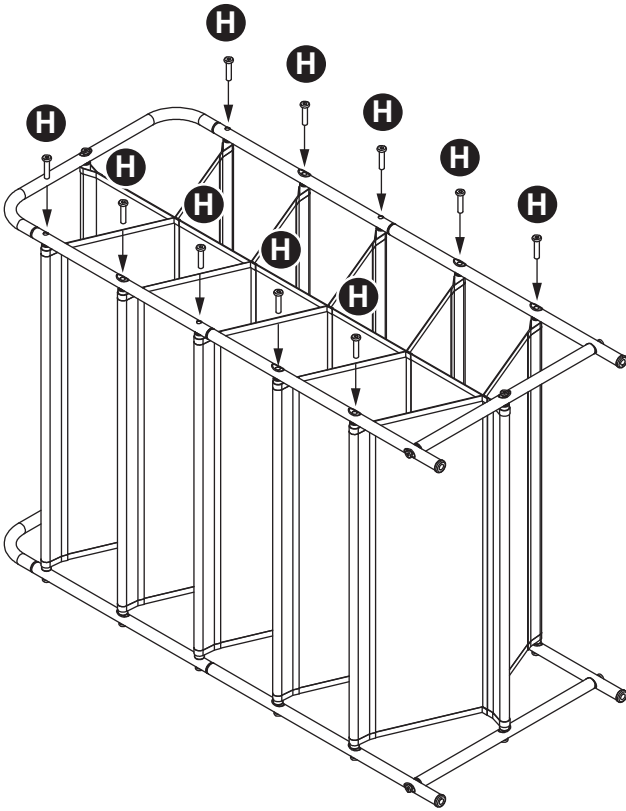

STEP 8:

- Insert wheels (D) on one side and two locking wheels (F) on the other side.

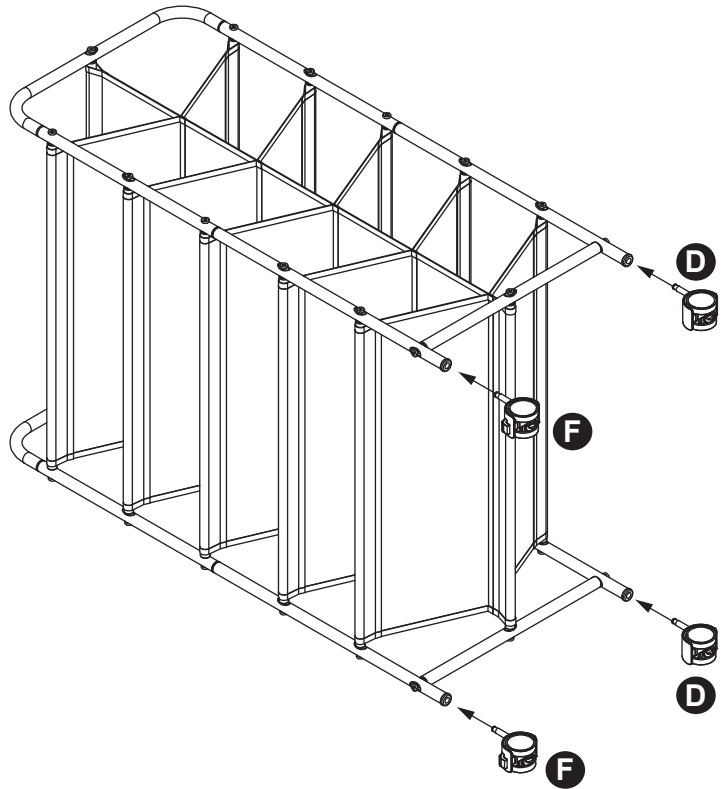

8680 Swinnea Road • Suite 103 • Southaven, MS • 38671

NEED HELP? For help with assembly, or if you are missing a part, please call Whitmor's Consumer Care Team, 1-888-944-8667 between 8 a.m. and 4:30 p.m. (Central Standard Time) Monday through Friday, or email: help@whitmor.com. Visit us online at www.whitmor.com