

Part	Reference
A	F11389
B	F11390
C	F11391
D	F11392
E	F11393
F	F11394
G	F11395

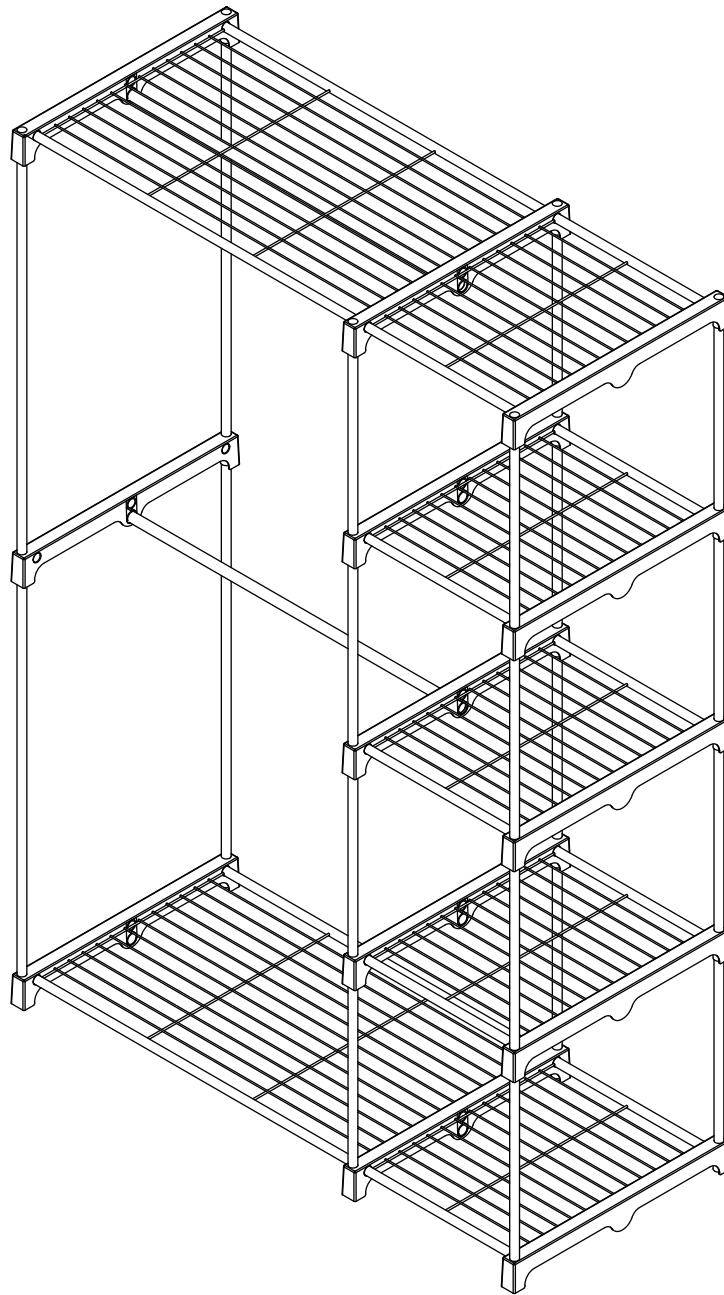

No tools required.



A 16 ea
Short Pole



B 4 ea
Long Pole

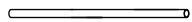

C 2 ea
Hanging Rod

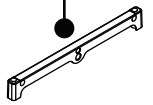
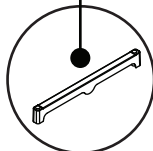
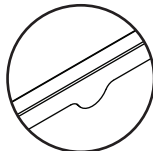

D 10 ea
End Connector

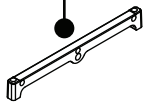
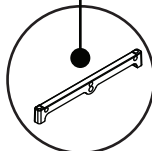
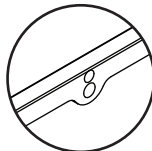

E 3 ea
Middle Connector

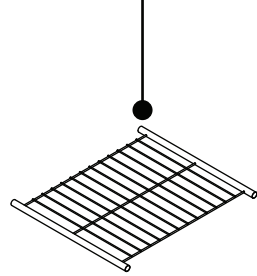
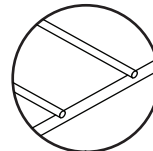

F 5 ea
Short Shelf

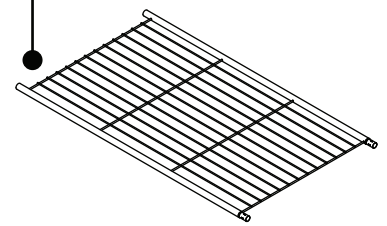
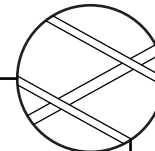

G 2 ea
Long Shelf

When placing the shelves make sure the thin wires are at the top.

STEP 1: Start by assembling the top, bottom and middle sections.

- **Bottom Section:** Insert the long shelf (G) and the short shelf (F) into two end connectors (D) and one middle connector (E) as shown below.
- **Top Section:** Repeat the step above while inserting the hanging rod (C) into end connector (D) and middle connector (E) as shown below.
- **Middle Section:** Insert the hanging rod (C) and the short shelf (F) into the two end connectors (D) and one middle connector (E) as shown below.

Note: All metal parts must be inserted firmly and completely into the plastic parts.

Top Section:

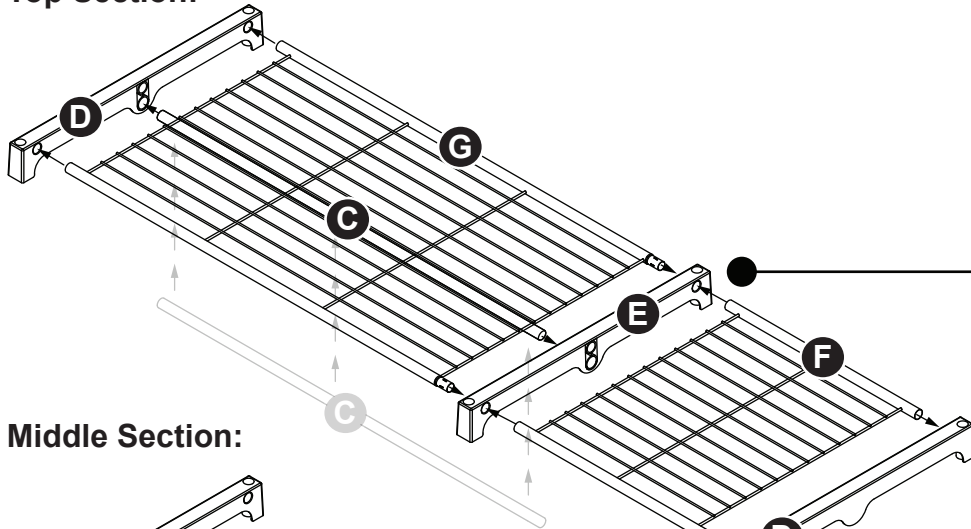

Middle Section:

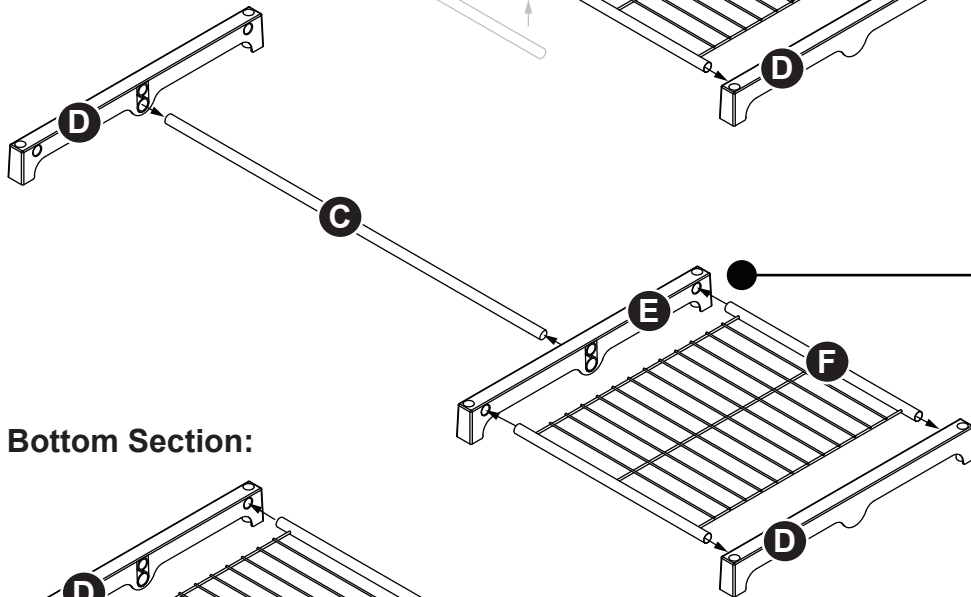

Bottom Section:

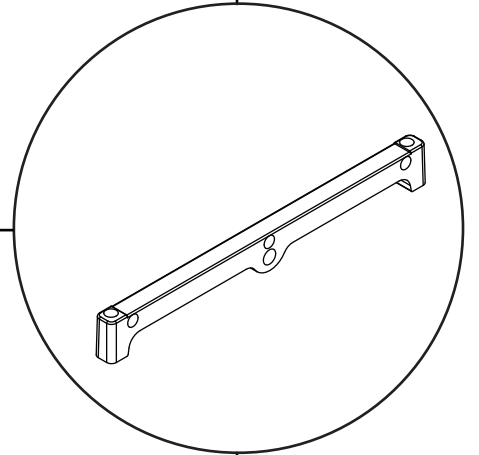
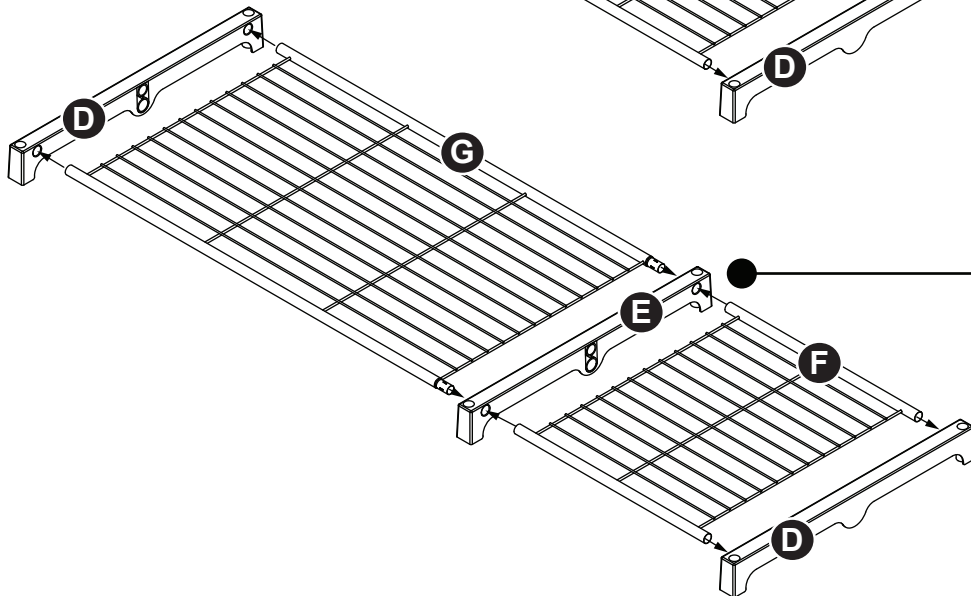

STEP 2: Short shelf assembly.

- Insert the short shelf (**F**) into the end connector (**D**) and middle connector (**E**).
- Repeat for the other short shelf.

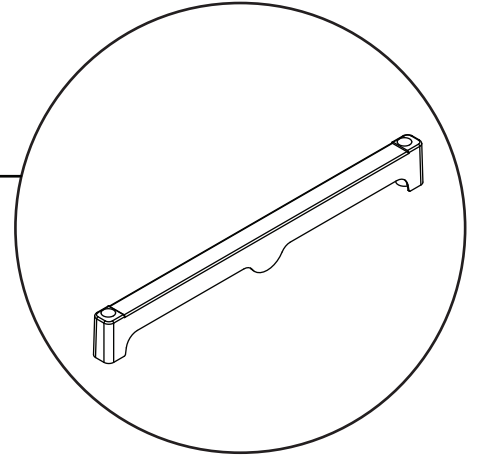
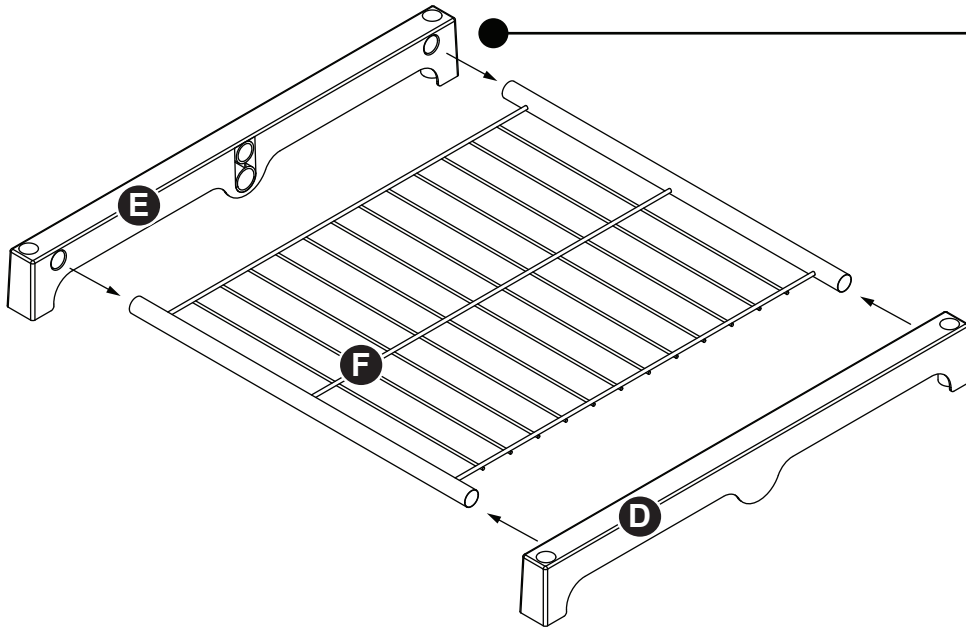

STEP 3:

Start from the assembled bottom section and build up.

- Insert short and long poles (A) and (B) into the connectors as the diagram shows.

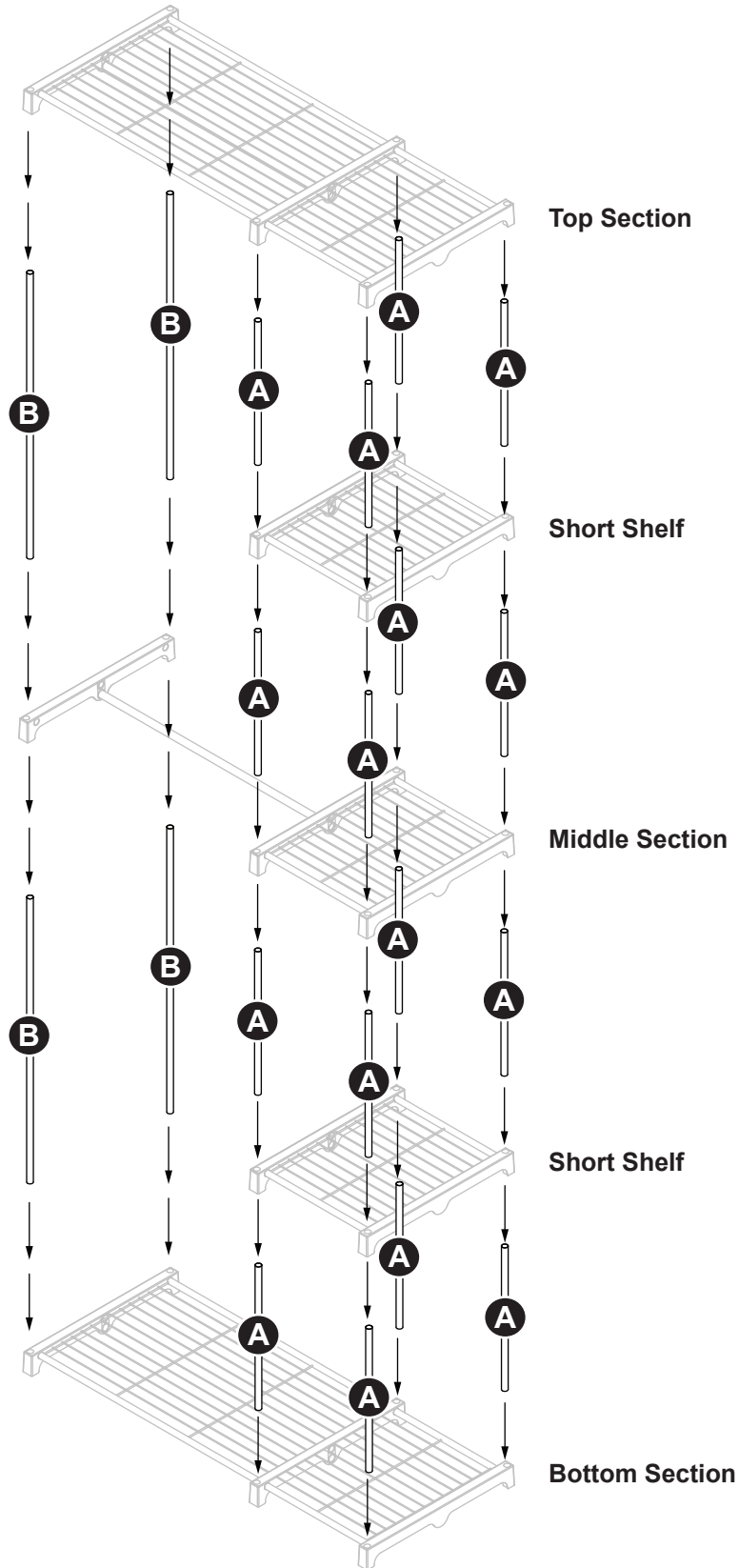

8680 Swinnea Road • Suite 103 • Southaven, MS • 38671

NEED HELP? For help with assembly, or if you are missing a part, please call Whitmor's Consumer Care Team, 1-888-944-8667 between 8 a.m. and 4:30 p.m. (Central Standard Time) Monday through Friday, or email: help@whitmor.com. Visit us online at www.whitmor.com