

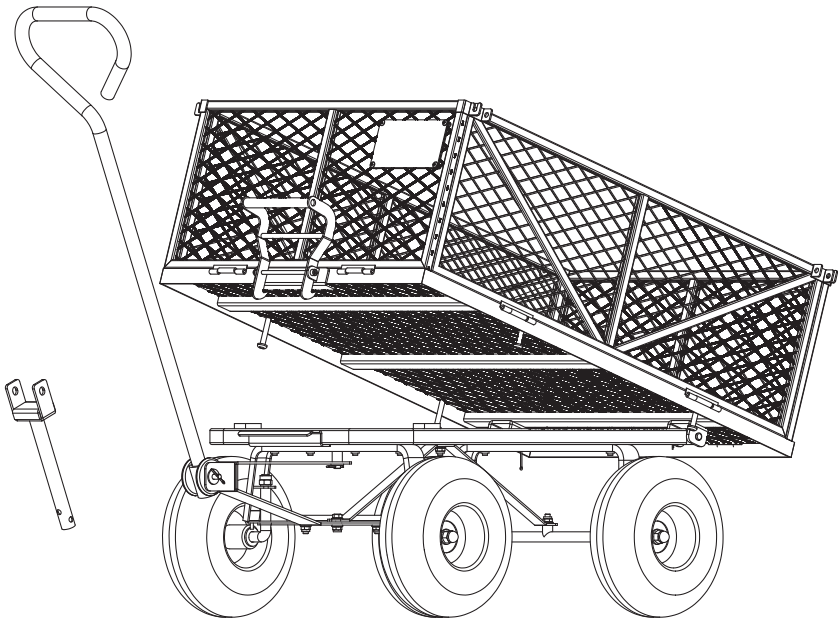

Garden Dump Cart Operator's Manual



WARNING:

Carefully review and understand all **INSTRUCTIONS** prior to operating this device. Failure to follow the safety rules and other basic safety precautions may result in serious personal injury. Keep these instructions in a safe place and accessible so that they can be reviewed as required. Keep these instructions to assist in future servicing needs.

WARNINGS

For your own safety, always follow these basic precautions when using this appliance.

1. Read the user Manual carefully for operating instructions. Read all instructions in this manual before use.
2. DO NOT overload this cart, the max load capacity is 660lbs (300kgs).
3. DO NOT inflate tires more than 30 PSI or less than 25PSI
4. DO NOT operate if any part is damaged or broken.
5. DO NOT operate under the influence of drugs or alcohol.
6. DO NOT use it to carry people, it could lead to personal injury.
7. DO NOT allow children to use this cart.
8. DO NOT turn violently when using, to avoid injury or property damage from falling items.
9. Keep your work area clean and well lit. Cluttered benches and dark areas invite accidents.

TECHNICAL SPECIFICATIONS

Load Capacity	660Lbs(300Kgs)
Dumper Bucket Dimension L*W*H	33*21.6*11.2 in.(840*550*284 mm)
Wheel size	10in.

MAIN COMPONENTS

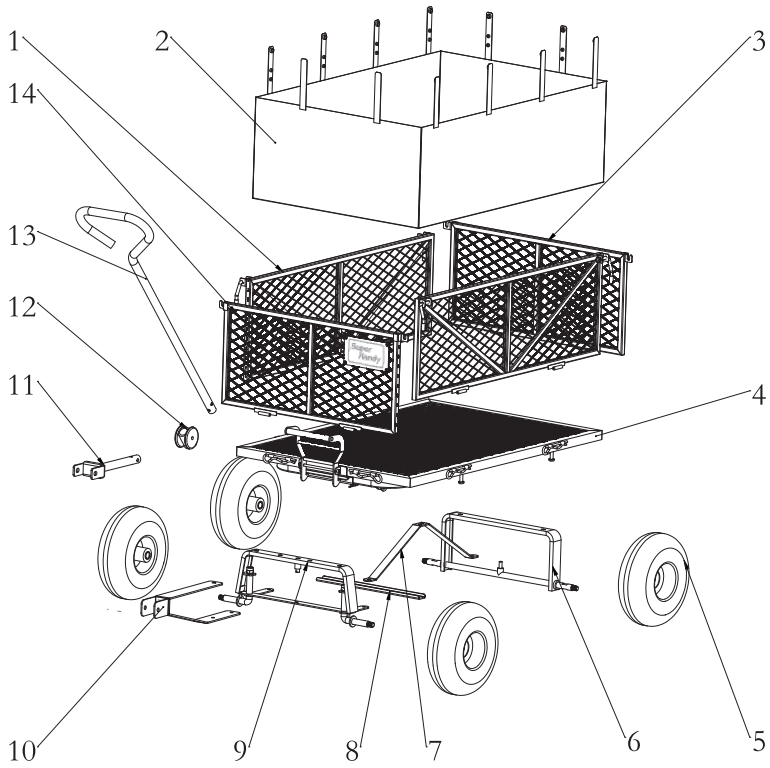

Fig.1

Part No.	Description	Q'ty	Part No.	Description	Q'ty
1	Side Panel	2	8	Connecting Linkage	1
2	Tarp Liner	1	9	Front Axle	1
3	Rear Panel	1	10	Steering Connector	1
4	Bed with Bottom Frame	1	11	Towbar	1
5	Wheel	4	12	Coupler	1
6	Rear Axle	1	13	Handle	1
7	Axle Support	1	14	Front Panel	1

ASSEMBLY

STEP 1 Front Axle and Connecting Linkage

Secure the Connecting Linkage (B) to the Front Axle (A) using 2 M8 nuts (C) and 2 M8 bolts (D). Ensure that the positional relationship between the Connecting Linkage (B) and the Front Axle (A) aligns as illustrated, with the Connecting Linkage's slot facing downward. Then, fasten the Front Axle (A) to the base using 4 M8 nuts (C).

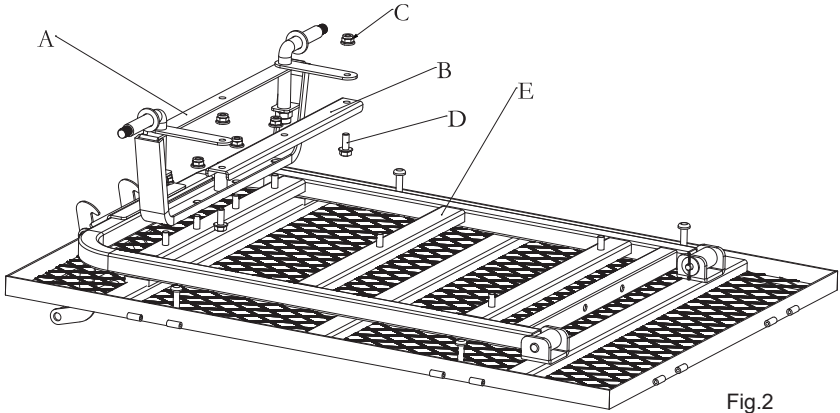

Fig.2

STEP 2 Rear Axle and Axle Support

Mount the Rear Axle (A) to the Bottom Frame (D) using two M8 nuts (C). Affix the Axle Support (B) to both the Bottom Frame (D) and the Rear Axle (A) as illustrated, using two M8 nuts (C) for each. When installing the Axle Support (B), pay attention to its orientation.

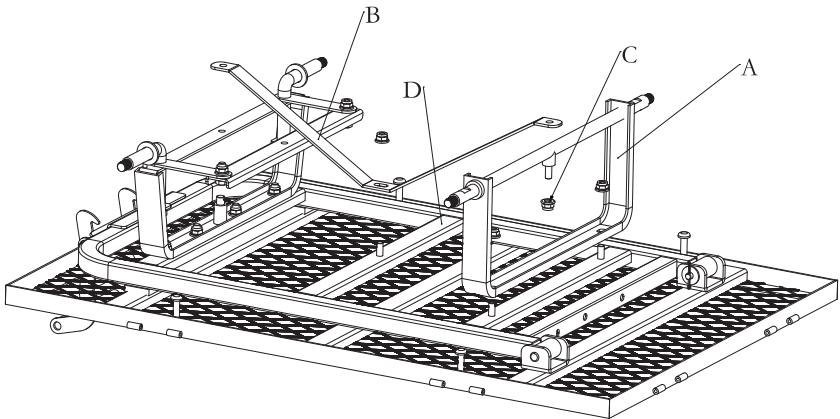

Fig.3

Note: It's recommended to first align the central mounting hole, then check the alignment of the other mounting hole. If they don't align, the installation direction is reversed. Simply swap the front and back orientation of the Axle Support (B) to achieve the correct installation.

STEP 3 Steering Connector

Secure the Steering Connector (A) to the Front Axle (B) and Connecting Linkage (E) using 2 M8 nuts (C), 2 M8 bolts (D), one M10 flat washer (F), and one cotter pin (G).

Note: Pay attention to the two bolt positions where the Steering Connector (A) connects with the Front Axle (B) and Connecting Linkage (E); they should be on the same side of the Steering Connector (A) without any vertical crossover. Also, be mindful of the vertical relationship among the Steering Connector (A), Front Axle (B), and Axle Support (H) when they are all fixed together using a single bolt and nut. The Axle Support (H) should be on the inner side of the Steering Connector (A) and Front Axle (B), as illustrated.

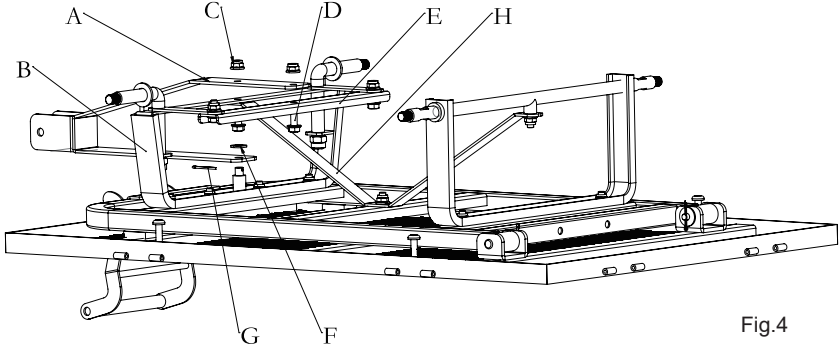

Fig.4

STEP 4 Wheels

Mount the 4 wheels (C) onto the Front Axle (A) and Rear Axle (B) using 4 flat washers (E), 4 spring washers (F), and 4 M12 nuts (D).

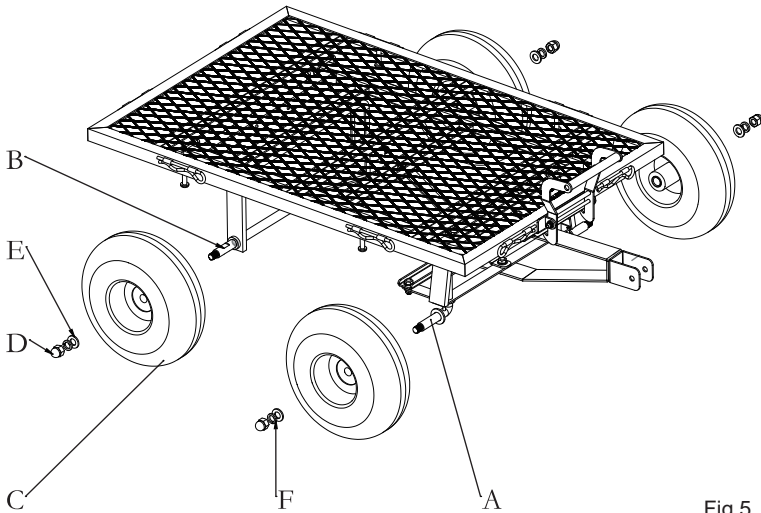

Fig.5

Step 5 Panels

First, flip the previously assembled part so that the tires are facing down. Then, attach the Front Panel (C), Rear Panel (B), and Side Panels (A) to the Bed using 8 type-B pins (D).

Note: Be sure to differentiate between the front and Rear Panel; the one with the nameplate is the Front Panel.

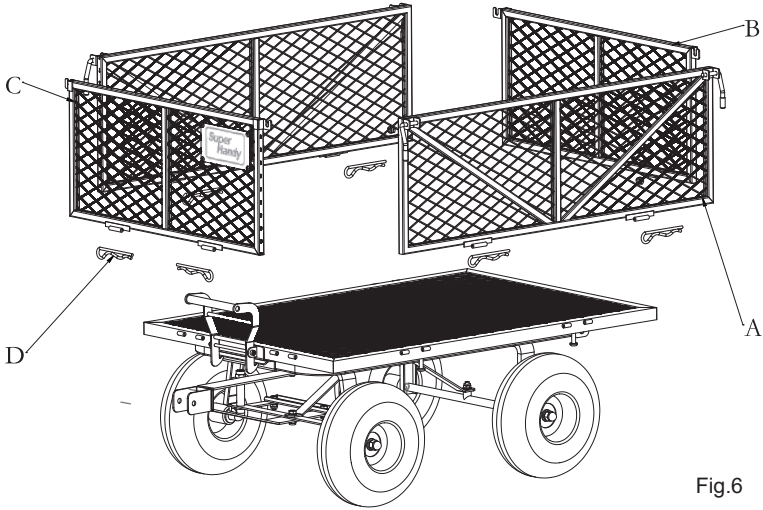

Fig.6

Note: In the diagram below, when installing the guardrails, all the hinges (A) on the guardrails should face outward, otherwise the installation will not be completed correctly.

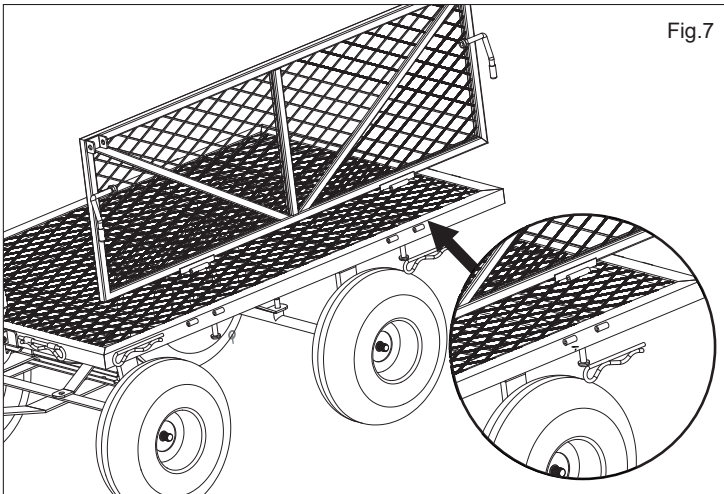

Fig.7

STEP 6 Handle

Slide the Coupler (B) onto the Handle (A) and secure it to Steering Connector using the pin shaft (C), 1 M8 washer (D), and 1 cotter pin (E).

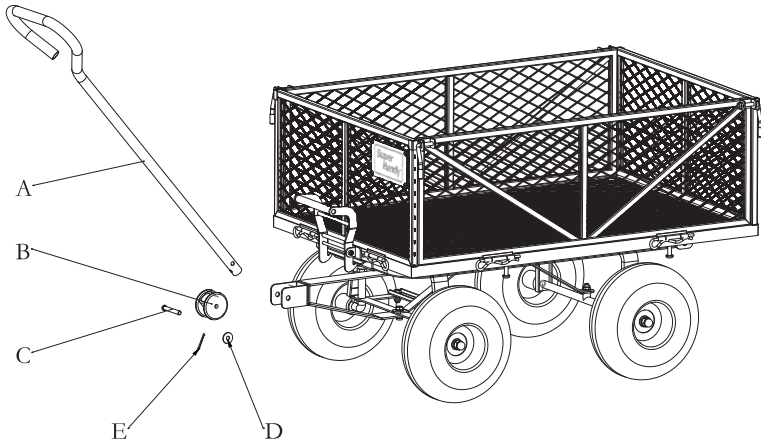

Fig.8

STEP 7 Towbar (Only needed when using for towing situation)

When using for towing situation, secure the Towbar (A) to the Steering Connector (B) using 1 pin shaft (C), 1 M8 washer (D), and 1 cotter pin (E).

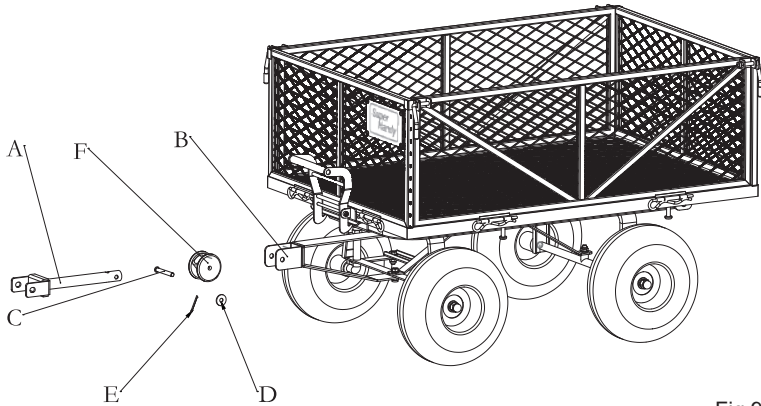

Fig.9

STEP 8 Tarp Liner

Figure 10 shows the Tarp Liner design. Item 1 and 2 are the male snap buttons, while item 3 is the female snap button.

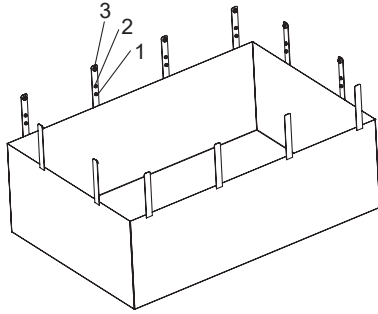

Fig.10

Position the Tarp Liner inside the cart's panels as shown in Figures 11. Secure the Tarp Liner to the panels of the cart.

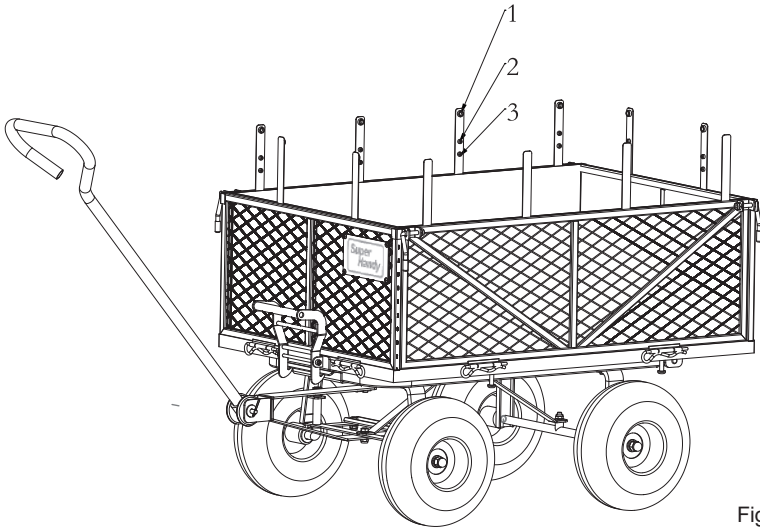

Fig.11



Fig.12



Fig.13

OPERATION

This device can be used in two different ways depending on the task. Please refer to the following description for details.

1. Utilized as a hand-pulled cart.

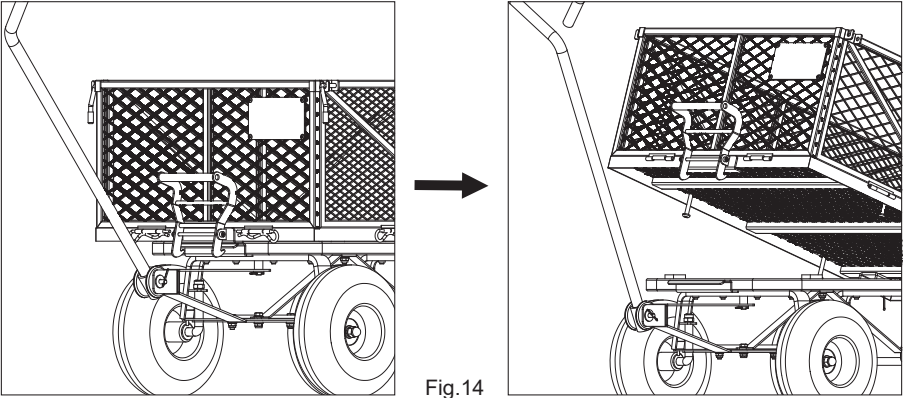

Fig.14

2. Utilized as a towing cart for tuggers.

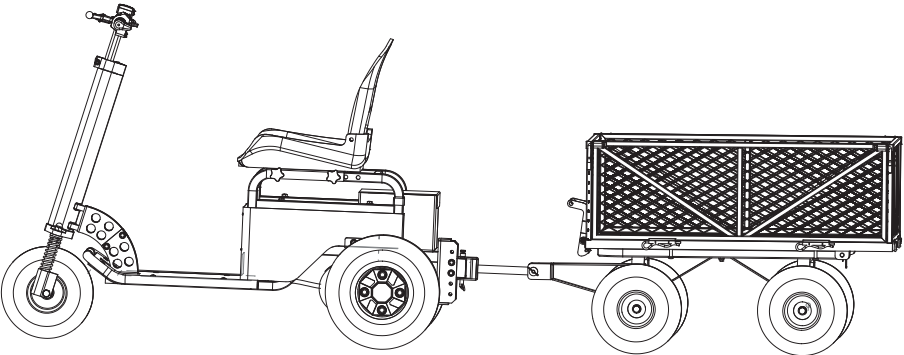

Fig.15

***Tow bar connection**

Fix the towbar (C) on the connect kit (A) with the coupling pin (B), and insert the R pin (D) to secure the coupling pin(B).

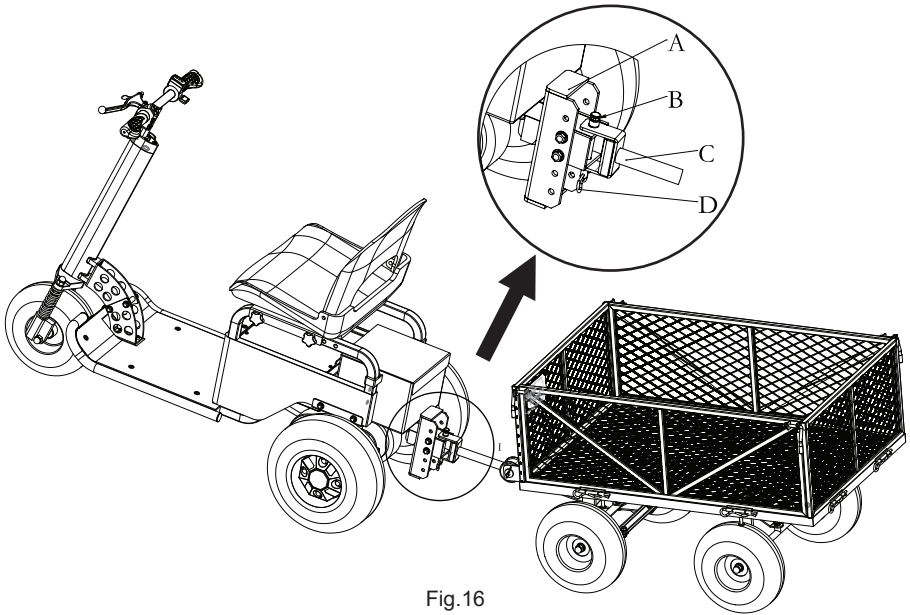

Fig.16

WARNING: Risk of being trapped and crushed!

- Do not reach into the open coupling.
- Check the coupling pin (B) of the tow coupling for damage.
- Ensure that the R pin (D) engages in the locating hole.

MAINTENANCE AND STORAGE

Maintain the cart by adopting a program of conscientious repair and maintenance. It is recommended that the general condition of any cart be examined before it is used. Keep your cart in good repair.

WARRANTY

Twelve (12) months for workmanship of the product, except for wearing parts. Warranty period starts from the product purchase date. Warranty covers material quality and workmanship only. Warranty does not cover product for issues caused by improper usage or any operation not in accordance with the specifications of this manual. Any modification or tampering with the product in any way voids the warranty.



Great Circle USA
Support Line: 1-866-493-0524
Email: help@greatcircleus.com
www.greatcircleus.com
www.greatcircleca.com



US



CA

Scan me to get more new products.