



24 in. RWD 3-in-1 Gas Walk Behind Self-Propelled Lawn Mower

Operator's Manual

MODEL NUMBER

YG4760

SERIAL NUMBER

PURCHASE DATE

Both model numbers and serial numbers may be found on the main label. (See **Page 2, Figure 1**) You should record both of them in a safe place for future use.

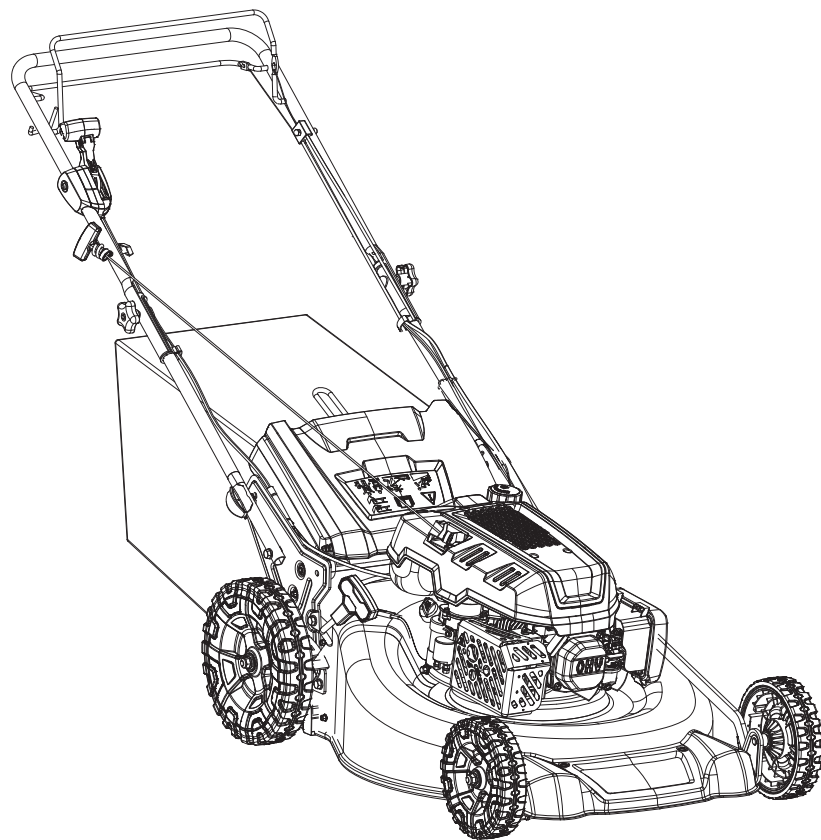

WARNING

READ AND UNDERSTAND THE ENTIRE MANUAL BEFORE OPERATING THE MACHINE. FAILURE TO COMPLY WITH THE SAFETY INSTRUCTIONS IN THE MANUAL MAY RESULT IN PERSONAL INJURY.



Your new YARDMAX® lawn mower offers quality construction and is easy and safe to operate. With proper use and care, it gives many years of dependable service.

Take on any job with ease, portability, and convenience while experiencing the durability of your new lawn mower!

Discover the YARDMAX Advantage

At YARDMAX, we understand that land ownership has its privileges, but it also comes with a great deal of responsibility. When duty calls and you need to respond, will you have what it takes to tame the great outdoors?

YARDMAX delivers the perfect combination of performance and practicality. An Outdoor Power Equipment (OPE) to get the job done right, at the right price. YARDMAX has a solution that's right for you.

MAX Performance, MAX Value, MAX Support – that's YARDMAX

- ✓ Backed by decades of proven manufacturing expertise
- ✓ Enhanced design features brings standard
- ✓ Engineered for the best user experience
- ✓ Quality metal used instead of plastic
- ✓ A robust warranty supports all products
- ✓ Budget-friendly prices make it practical



Up for the job? YARDMAX is.

TABLE OF CONTENTS

Introduction	1	Know Your Machine	13
Specifications	4	Operation	15
Symbols	5	Maintenance	19
Safety	6	Transport & Storage	25
Contents Supplied	10	Troubleshooting	26
Assembly	11	Parts Diagram	28

⚠ WARNING *Carefully read through this entire operator's manual before using your new unit. Pay attention to all cautions and warnings.*

This walk-behind self-propelled lawn mower is intended to be used by residential homeowners. It is designed primarily for cutting grass on well-maintained lawns on residential properties. It is not designed for cutting brush or for agricultural uses. It starts easy and cuts cleanly. The efficiency of the cutting system leaves your lawn looking spotless and clean.

ENGINE MANUAL

The **Engine Manufacturer** is responsible for all engine-related issues with regard to performance, power rating, specifications, warranty, and service. For more information, please refer to the Engine Manufacturer's owner/operator's manual, packed separately with your unit.

EMISSION CONTROL SYSTEM

This equipment or its engine may include exhaust and evaporative emission control system components required to meet U.S. Environmental Protection Agency (EPA) and/or California Air Resources Board (CARB) regulations. Tampering with emission controls and components by unauthorized personnel may result in severe fines or penalties. Emission controls and components can only be adjusted by an authorized engine manufacturer's service center.

⚠ WARNING CALIFORNIA PROPOSITION 65 WARNING
Engine exhaust, some of its constituents and certain product components contain or emit chemicals known to the state of California to cause cancer and birth defects, or other reproductive harm. For more information, go to www.P65Warnings.ca.gov.

ENVIRONMENTAL



Recycle unwanted materials instead of disposing of them as waste. All tools, hoses, and packaging should be sorted, taken to the local recycling center, and disposed of in an environmentally safe way.

YG4760PM02 - 2501

MODEL AND SERIAL NUMBERS

Record the model and serial number as well as date and place of purchase for future reference. Have this information handy when ordering parts/accessories, or when making technical/warranty inquiries.

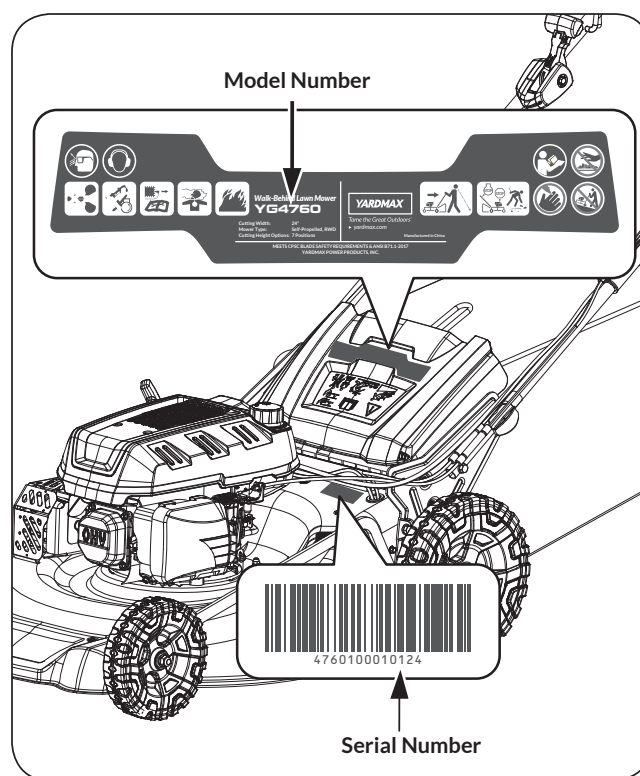
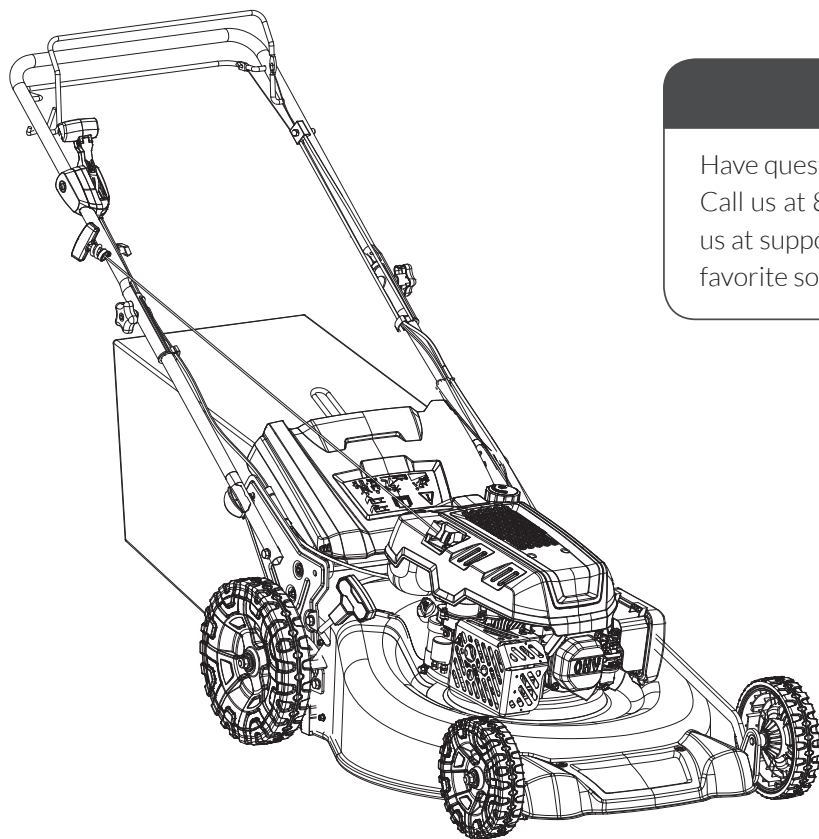
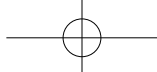

Figure 1

DISCLAIMER

YARDMAX reserves the right to discontinue, change, and improve its products at any time without notice or obligation to the purchaser. The descriptions and specifications contained in this manual were in effect at printing. The equipment described within this manual may be optional. Some illustrations may not apply to your unit.



SUPPORT

Have questions about your YARDMAX equipment?
Call us at 847-327-0566 or 844-YARDMAX, email
us at support@yardmax.com, or contact us via your
favorite social media site.

YG4760 SPECIFICATIONS

Model #	YG4760
Mower Type	Self-Propelled, RWD
Cutting Options	Bag, Mulch, Rear Discharge
Cutting Width	24"
Max. Cutting Height	3.74"
Min. Cutting Height	1.57"
Cutting Height Options	7 positions
Deck Material	13 Gauge
Deck Type	Stamped
Rear Bag Capacity	2.83 cu.ft. (80L)
Engine	YARDMAX
Power Type	Gas
Starting System	Recoil
Displacement	201 cc
Engine Torque	9 ft.-lb
Fuel Tank Capacity	0.34 gallon (1.3L)
Oil Capacity	16.9 oz. (0.5L)
Recommended Oil Type	SAE 10W-30
Wheels (Front)	8"
Wheels (Back)	11"
Rear Wheel Height	High Wheel
Wheel Width (Front)	2"
Wheel Width (Back)	2.2"
Double Ball Bearing Wheels	Yes
Recommended Terrain	Flat, Sloped, Uneven
Size of Yard	1/2-1 1/2 Acre
Number of Blades	1
Number of Handlebar Positions	3
Weight (lbs)	97.6 lbs
Assembled Dimensions (D × W × H)	70.9" x 25.6" x 40.39"

SYMBOLS

The rating plate on your machine may show symbols. These represent important information about the product or instructions on its use.



DANGER
WARNING
CAUTION



FAST



SLOW



Read these instructions carefully.



Wear approved hearing protection.



Wear eye protection with side shields marked to comply with ANSI Z87.1.



Do not touch parts that are hot from operation. Delete the highlighted line. Add 'It may result in serious burns'. Engine parts, especially the muffler, become extremely hot during operation. Allow engine and muffler to cool before touching.



Use extra caution on slopes. The machine is heavy and can speed up when going downhill. Be prepared to maintain control of the machine. To avoid loss of control, operate across slopes, not up and down. When turning, turn uphill, not down. Do not operate on slopes greater than 15°.



To reduce the risk of injury, keep hands and feet away from all pinch points, especially the cutting blades. Do not operate unless the discharge cover or grass bagger is in its proper place. If damaged, replace it immediately.



Never start or run the engine inside a closed or poorly ventilated area.

The engine exhaust contains carbon monoxide, an odorless and deadly gas.

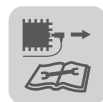

Shut off the engine, disconnect the spark plug wire, and make sure all moving parts have stopped before cleaning, repairing, or inspecting the unit.



Always stop the engine before refueling.



Gasoline and its vapors are extremely flammable and explosive. Never fuel the machine indoors or while the engine is hot or running. Wipe up any gasoline that spills. Keep away from any flammables when operating the engine.



Keep hands and feet away from moving parts. Moving parts can crush or cut.



Make sure the engine is off when leaving the mower or not mowing.



Before and while walking backward, look behind and down for small children, animals, or other risks that can cause you to fall.



Keep hands and feet away.

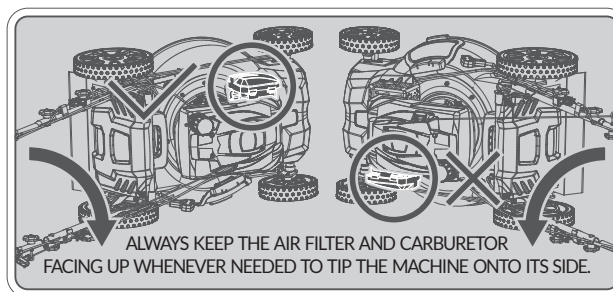

SAFETY

The definitions below give the level of severity for each signal word.



DANGER

This symbol points out important safety instructions. This machine was built to be operated according to the safe operation practices in this manual. Carelessness or error on the part of the operator can result in serious injury. This machine is capable of amputating fingers, hands, toes, and feet and throwing foreign objects. Failure to observe the safety instructions could result in serious injury or death.



WARNING

This symbol points out safety instructions. Read and follow all instructions before attempting to operate this machine. Failure to comply with these instructions may result in personal injury.



CAUTION

This symbol indicates a hazard, which, if not avoided, may result in minor or moderate injury.



NOTE

This information makes the product easier to use.

GENERAL SAFETY RULES

UNDERSTAND YOUR MACHINE

Read this manual and the labels affixed to the machine to understand its limitations and potential hazards before attempting to assemble this machine. Read, understand, and follow all instructions on the machine and in the manuals before operation.

Be thoroughly familiar with the controls and their proper operation. Know how to stop the machine and disengage the controls quickly.

Make sure to read and understand all the instructions and safety precautions as outlined in the Engine Manufacturer's manual packed separately with your unit. Do not attempt to operate the machine until you fully understand how to properly operate and maintain the engine and how to avoid accidental injuries and/or property damage.

Keep this manual and engine manual in a safe place for future and regular reference.

If the unit is to be used by someone other than the original purchaser or loaned, rented, or sold, always provide this manual and any needed safety training before operation. The user can prevent and is responsible for accidents or injuries that may occur to themselves, other people, and property.

This machine is a precision piece of power equipment, not a plaything. Therefore, exercise extreme caution at all times. This

machine has been designed to perform one job: to mow the grass. Do not use it for any other purpose.

Do not force the machine. Use the machine correctly. The machine does the job more efficiently and safely at the rate it was designed.

PERSONAL SAFETY

Do not permit children to operate this machine at any time. Only responsible individuals who are familiar with these rules of safe operation should be allowed to use this machine.

To help avoid blade contact or a thrown object injury, stay in the operator zone behind handles and keep children, pets, and other people not using the unit away from the work area. Be alert and shut off the unit if anyone enters the work area. Keep children under the watchful care of a responsible adult.

Thoroughly inspect the area where the equipment is to be used. Remove all stones, sticks, wire, bones, toys, and other foreign objects, which could be tripped over or picked up and thrown by the blade. Thrown objects can cause serious personal injury.

Plan your mowing pattern to avoid the discharge of material toward roads, sidewalks, bystanders, and the like. Also, avoid discharging material against a wall or obstruction, which may cause discharged material to ricochet back toward the operator; this may cause personal injury.

Do not operate the machine while under the influence of drugs,

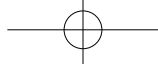

alcohol, or any medication that could affect your ability to use it properly.

Wear sturdy, rough-soled work shoes and close-fitting slacks and shirts. Shirts and pants that cover the arms and legs and steel-toed shoes are recommended. Never operate this machine in bare feet, sandals, slippery or lightweight (e.g., canvas) shoes.

Protect eyes, face, and head from objects that may be thrown from the unit. Always wear safety goggles or safety glasses with side shields when operating and while performing an adjustment or repair.

Always use approved ear protection while you operate the product. Noise for a long period can cause noise-induced hearing loss.

Always keep hands and feet away from all moving parts and under the cutting deck. Contact with moving parts and/or blades can amputate fingers, hands, toes, and feet.

A missing or damaged discharge cover can cause blade contact or thrown object injuries. Do not use a damaged product. Obey the maintenance schedule. Only do the maintenance work that you find an instruction about in this manual.

ENGINE SAFETY

⚠ WARNING *This machine is equipped with an internal combustion engine and should not be used on or near any unimproved forest-covered, brush-covered or grass-covered land unless the engine's exhaust system is equipped with a spark arrestor meeting applicable local or state laws (if any).*

If a spark arrestor is used, it should be maintained in effective working order by the operator. In the State of California, the above is required by law (Section 4442 of the California Public Resources Code). Other states may have similar laws. Federal laws apply on federal lands.

Never start or run the engine inside a closed area. The exhaust fumes are dangerous, containing carbon monoxide, an odorless and deadly gas.

Operate this unit only in a well-ventilated outdoor area.

Do not tamper with the engine to run it at excessive speeds. The maximum engine speed is preset by the manufacturer and is within safety limits. See engine manual.

The muffler keeps the noise levels to a minimum and sends the exhaust fumes away from the operator. Do not use the product if the muffler is missing or defective. A defective muffler increases

the noise level and the risk of fire. Examine the muffler regularly to make sure that it is attached correctly and not damaged.

Muffler and engine become hot and can cause burns. Do not touch.

Do not modify the engine. To avoid serious injury or death, do not modify the engine in any way. Tampering with the governor setting can lead to a runaway the engine and cause it to operate at unsafe speeds. Never tamper with the factory setting of the engine governor.

FUEL SAFETY

Fuel is highly flammable, and its vapors can explode if ignited. Take precautions when using to reduce the chance of serious personal injury.

When refilling or draining the fuel tank, use an approved fuel storage container while in a clean, well-ventilated outdoor area. Do not smoke, or allow sparks, open flames, or other sources of ignition near the area while adding fuel or operating the unit. Never fill the fuel tank indoors.

Keep grounded conductive objects, such as tools, away from exposed, live electrical parts and connections to avoid sparking or arcing. These events could ignite fumes or vapors.

Always stop the engine and allow it to cool before filling the fuel tank. Never remove the cap of the fuel tank or add fuel while the engine is running or when the engine is hot. Do not operate the machine with known leaks in the fuel system.

Loosen the fuel tank cap slowly to relieve any pressure in the tank.

Never overfill the fuel tank. Fill the tank to no more than 1/2" below the bottom of the filler neck to provide space for expansion as the heat of the engine can cause fuel to expand.

Replace all fuel tank and container caps securely and wipe up spilled fuel. Never operate the unit without the fuel cap securely in place.

Avoid creating a source of ignition for spilled fuel. If fuel is spilled, do not attempt to start the engine but move the machine away from the area of spillage and avoid creating any source of ignition until fuel vapors have dissipated.

Do not start the product if there is fuel or engine oil on the product. Remove the unwanted fuel/oil and let the product dry.

When fuel is spilled on yourself or your clothes, wash your skin and change clothes immediately.

Store fuel in containers specifically designed and approved for this purpose.

Store fuel in a cool, well-ventilated area, safely away from sparks, open flames, or other sources of ignition.

Never store fuel or a machine with fuel in the tank inside a building where fumes may reach a spark, open flame, or any other source of ignition, such as a water heater, furnace, or clothes dryer. Allow the engine to cool before storing it in any enclosure.

Product liability

As referred to in the product liability laws, we are not liable for

damages that our product causes if:

- remove the product is incorrectly repaired.
- remove the product is repaired with parts that are not from the manufacturer or not approved by the manufacturer.
- remove the product has an accessory that is not from the manufacturer or not approved by the manufacturer.
- remove the product is not repaired at an approved service center or by an approved authority.

SPECIFIC SAFETY RULES

OPERATION SAFETY

This machine has been designed to perform one job: to mow grass. Do not use it for any other purpose.

Operate the product only in daylight or in good artificial light. Walk, never run.

Stop the blade when crossing gravel drives, walks, or roads.

A missing or damaged discharge cover can cause blade contact or thrown object injuries.

Many injuries occur as a result of the mower being pulled over the foot during a fall caused by slipping or tripping. Do not hold on to the mower if you are falling: release the handle immediately.

Never pull the mower back toward you while you are walking. If you must back the mower away from a wall or obstruction, first look down and behind to avoid tripping, and then follow these steps:

- Step back from the mower to fully extend your arms forward.
- Be sure you are well balanced with sure footing.
- Pull the mower back slowly, no more than halfway toward you.
- Repeat these steps as needed.

Do not touch parts that are hot from operation. Allow parts to cool before attempting to maintain, adjust, or service. Serious burns may result. Engine parts, especially the muffler, become extremely hot during operation. Allow engine and muffler to cool before touching.

Stay alert, watch what you are doing, and use common sense when operating the machine.

Do not overreach. Do not operate the machine while barefoot or when wearing sandals or similar lightweight footwear. Wear protective footwear that will protect your feet and improve your footing on slippery surfaces. Keep proper footing and

balance at all times. This enables better control of the machine in unexpected situations.

Do not engage the drive control lever before move the speed control lever to the 1st position for lowest speed.

Do not engage the self-propelled mechanism on machines so equipped while starting the engine.

The blade control lever (engine start/stop control lever) is a safety device. Never attempt to bypass its operation. Doing so makes the safety device inoperative and may result in personal injury through contact with the rotating blade. The blade control lever (engine start/stop control lever) must operate easily in both directions and automatically return to the disengaged position when released.

Never operate the mower on wet grass. Always be sure of your footing. A slip and fall can cause serious personal injury. If you feel you are losing your footing, release The blade control lever (engine start/stop control lever) immediately and the blade will stop rotating within three seconds.

Shut the engine off and wait until the blade comes to a complete stop before removing the grass bagger or unclogging the chute. The cutting blade continues to rotate for a few seconds after the blade control is released. Never place any part of the body in the blade area until you are sure the blade has stopped rotating.

Never operate a mower without a proper trail shield, discharge cover, grass bagger, blade control lever (engine start/stop control lever), or other safety protective devices in place and working. Never operate a mower with damaged safety devices. Failure to do so can result in personal injury.

Never attempt to make a wheel or cutting height adjustment while the engine is running.

When starting the engine, pull the cord slowly until resistance is felt, then pull rapidly. Rapid retraction of the starter cord (kickback) will pull hand and arm toward the engine faster than you can let go. Broken bones, fractures, bruises, or sprains could result.

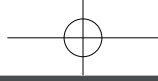

If the equipment should start to vibrate abnormally, stop the engine and check immediately for the cause. Vibration is generally a warning of trouble.

This manual cannot include all situations that can occur when you use the product. Be careful and use your common sense. Do not operate the product or do maintenance to the product if you are not sure about the situation. Contact Customer Support for assistance.

SLOPE OPERATION

Slopes are a major factor related to slip and fall accidents, which can result in severe injury. Operation on slopes requires extra caution. The machine is heavy and can speed up when going downhill. Be prepared to maintain control of the machine. If you feel uneasy on a slope, do not mow it. If the slope is greater than 15 degrees, do not mow it.

Mow across the face of slopes, never up and down, to avoid loss of control. Exercise extreme caution when changing direction on slopes; watch for holes, ruts, rocks, hidden objects, or bumps that can cause you to slip or trip. Tallgrass can hide obstacles.

Always be sure of your footing. A slip and fall can cause serious personal injury. If you feel you are losing your balance, release the blade control handle immediately and the blade will stop rotating.

Do not mow near drop-offs, ditches, or embankments, because you could lose your footing or balance.

WORK AREA SAFETY

Remove branches, twigs, stones, and other objects from the lawn before you start to cut.

Keep persons, including children, and animals at a safe distance from the work area.

Objects that hit against the cutting equipment can be ejected and cause damage to persons and objects.

Do not use the product in bad weather, including fog, rain, moist or wet locations, strong winds, intense cold, and risk of lightning. Doing work in bad weather can cause fatigue and dangerous conditions, such as slippery surfaces.

Examine your work area to make sure that your control of the product cannot be prevented.

Be careful of roots, stones, twigs, pits, and ditches.

High grass can conceal obstacles.

Operate the product only in daylight or in good artificial light.

Do not operate the product on wet grass.

Be careful when you go near hidden corners and objects that can prevent your view.

Maintain a high level of caution when you reverse or pull the product in your direction.

MAINTENANCE SAFETY

Before cleaning, repairing, or inspecting the product, stop the engine and make certain the blade and all moving parts have stopped. Disconnect the spark plug wire and ground against the engine and remove Electric Start Push Key (if equipped) to prevent unintended starting.

Check the blade and engine mounting bolts at frequent intervals for proper tightness. Also, visually inspect the blade for damage (e.g., bent, cracked, worn). Replace blade with the Original Equipment Manufacturers (O.E.M.) blade only, listed in this manual. The use of parts that do not meet the original equipment specifications may lead to improper performance and compromise safety!

Mower blades are sharp and can cut. Wrap the blade or wear gloves, and use extra caution when servicing them.

Keep all nuts, bolts, and screws tight to be sure the equipment is in safe working condition.

Accessories and changes to the product that are not approved by the manufacturer can cause serious injury or death. Do not alter the product. Always use accessories that are approved by the manufacturer.

Deflectors, guards, and shields decrease the risk of objects being ejected from the product in the direction of the operator or other persons. Make sure the deflectors, guards, and shields are not damaged and that no defects are in views, such as cracks, broken springs, or missing hardware. Replace any damaged or missing parts.

If the maintenance is not done correctly and regularly, the risk of injury and damage to the product increases.

CONTENTS SUPPLIED

Your YARDMAX lawn mower contains the following:

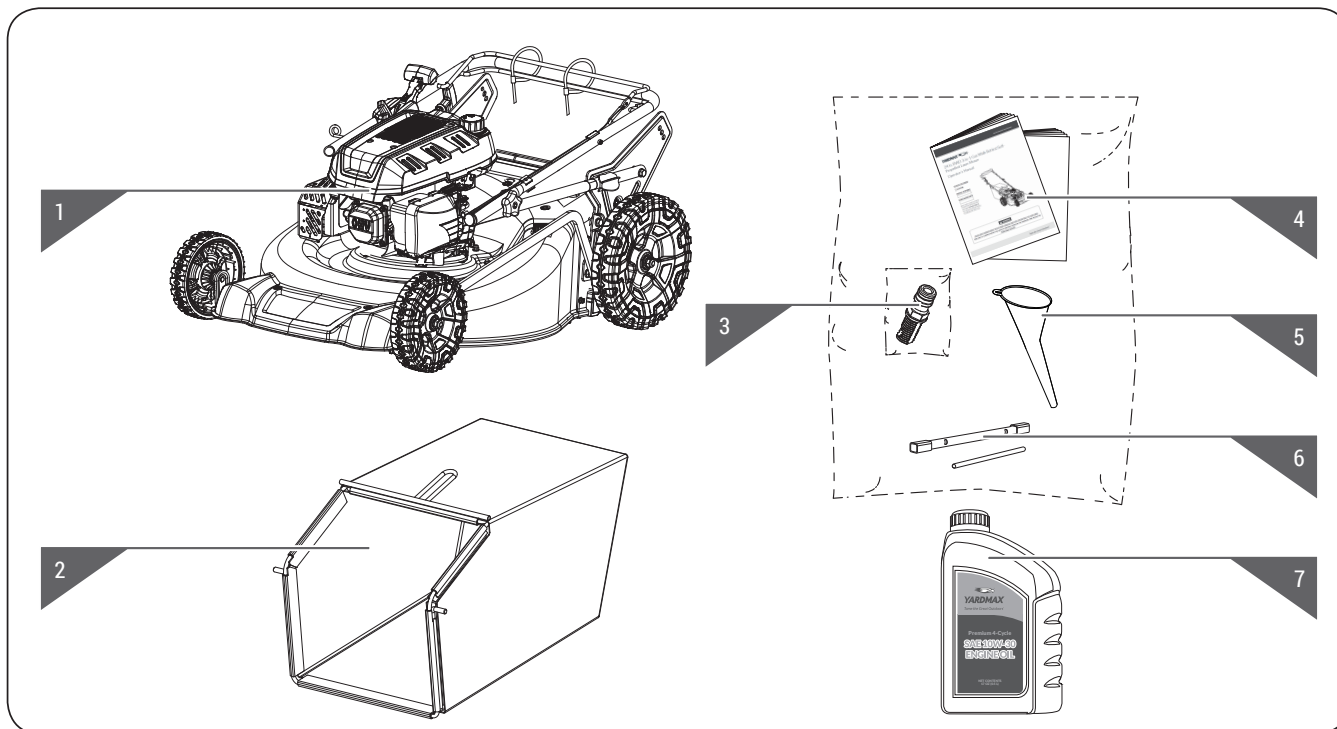

1. Main Machine
2. Grass Catcher
3. Product Adapter

4. Operator's Manual and Engine Manual
5. Funnel
6. Tools for Spark Plug Assembly
7. Engine Oil

ASSEMBLY

This lawn mower comes assembled and only needs simple unfolding and fastening. Follow the below instructions:

HANDLEBARS

1. Slowly move the folded handlebars back to the working position. (See **Figure 2, illustration 1**)
2. Unlocking the knobs, attached the short studs into any one of the three holes in the handle bracket. (See **Figure 2, illustration 2**)

NOTE

The three holes in the handle bracket are for three different handle heights. Quickly switch between the three holes by unlocking the knob, adjusting and then releasing.

3. Tighten the wing knobs and bolts that connected the upper handle and the lower connecting handlebars. (See **Figure 2, illustration 3**)
4. Cut the cable tie to release the engine start/stop control lever and the drive control lever. (See **Figure 2, illustration 4**)

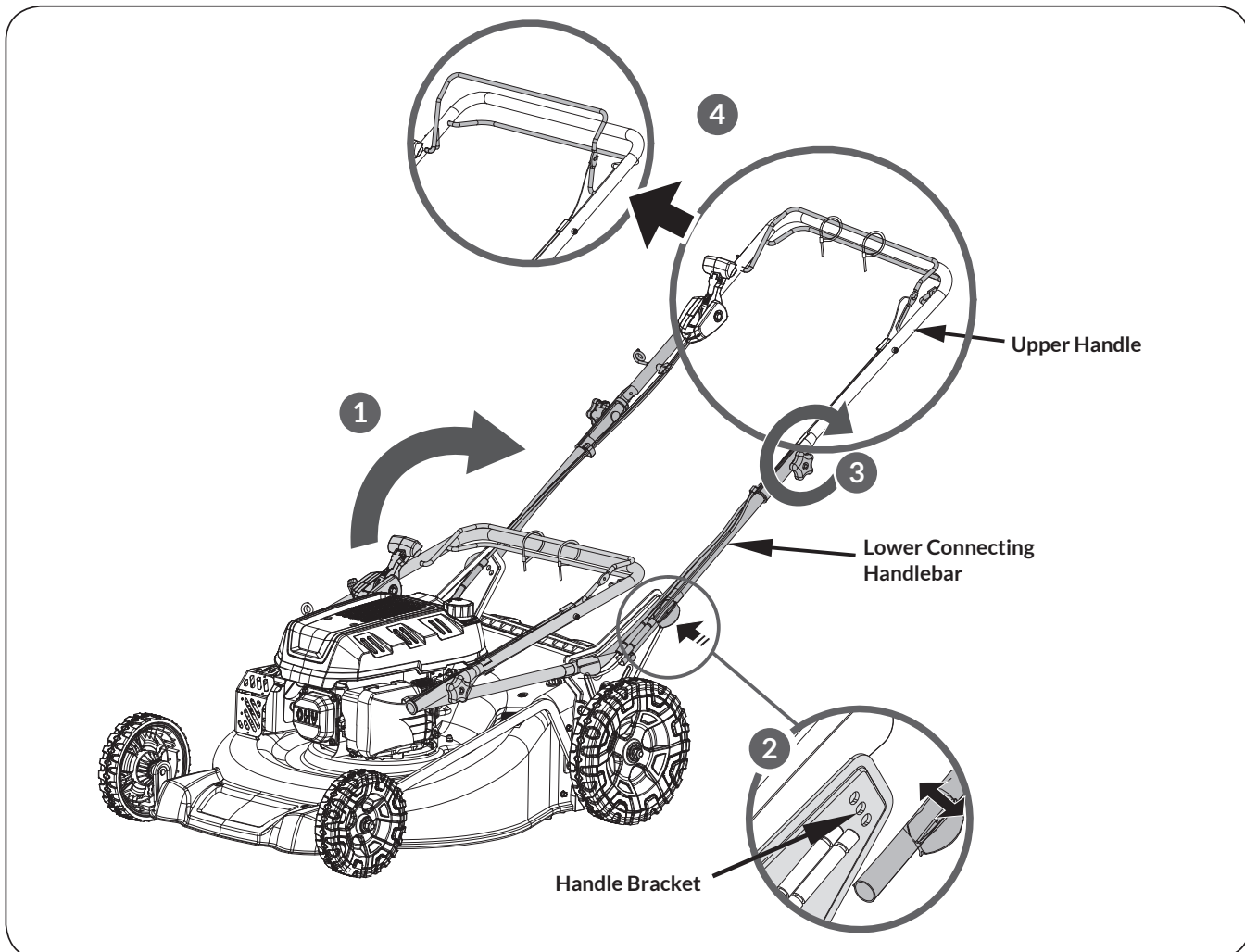

Figure 2

ENGINE STARTER POSITIONING

1. Hold the engine start/stop control lever against the upper handle. (See **Figure 3, Illustration 1**)
2. Slowly pull the starter rope handle from the engine and slip the starter rope into the rope guide. (See **Figure 3, Illustration 2**)

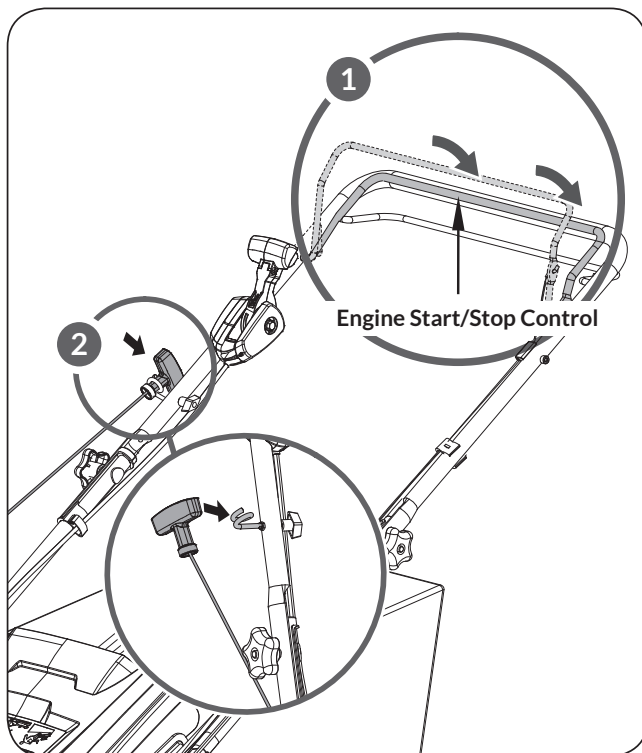

Figure 3

GRASS CATCHER

1. Lift the mower's rear discharge door. (See **Figure 4**)
2. Lift up and pull back the mulch plug to remove it. (See **Figure 5**)
3. Slide the support studs at the front of the grass catcher frame into the V-shaped groove of the left and right handle brackets. Let go of the rear discharge door so that it rests on the grass catcher. (See **Figure 6, illustration 1&2**)

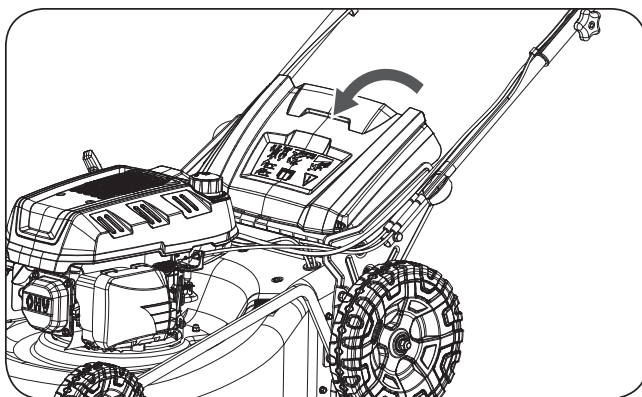

Figure 4

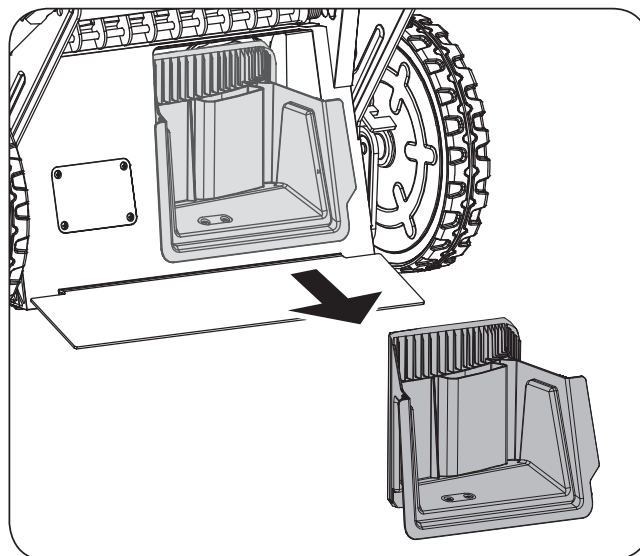

Figure 5

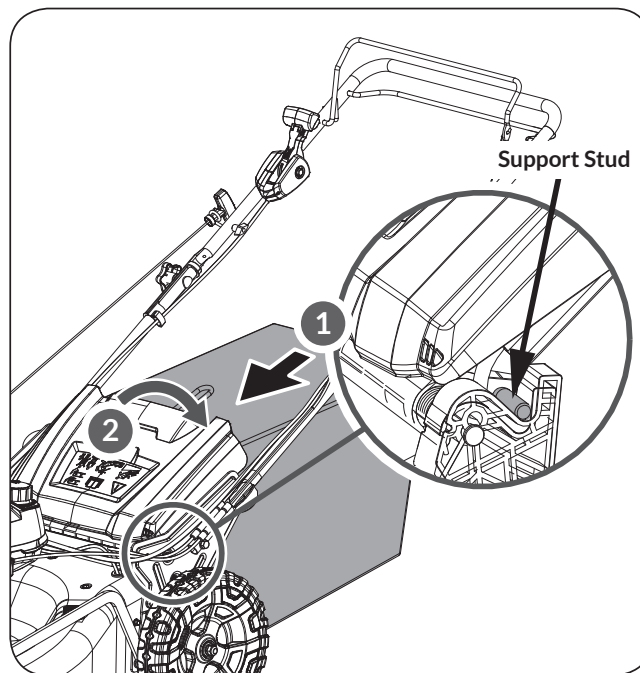
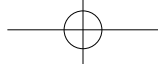
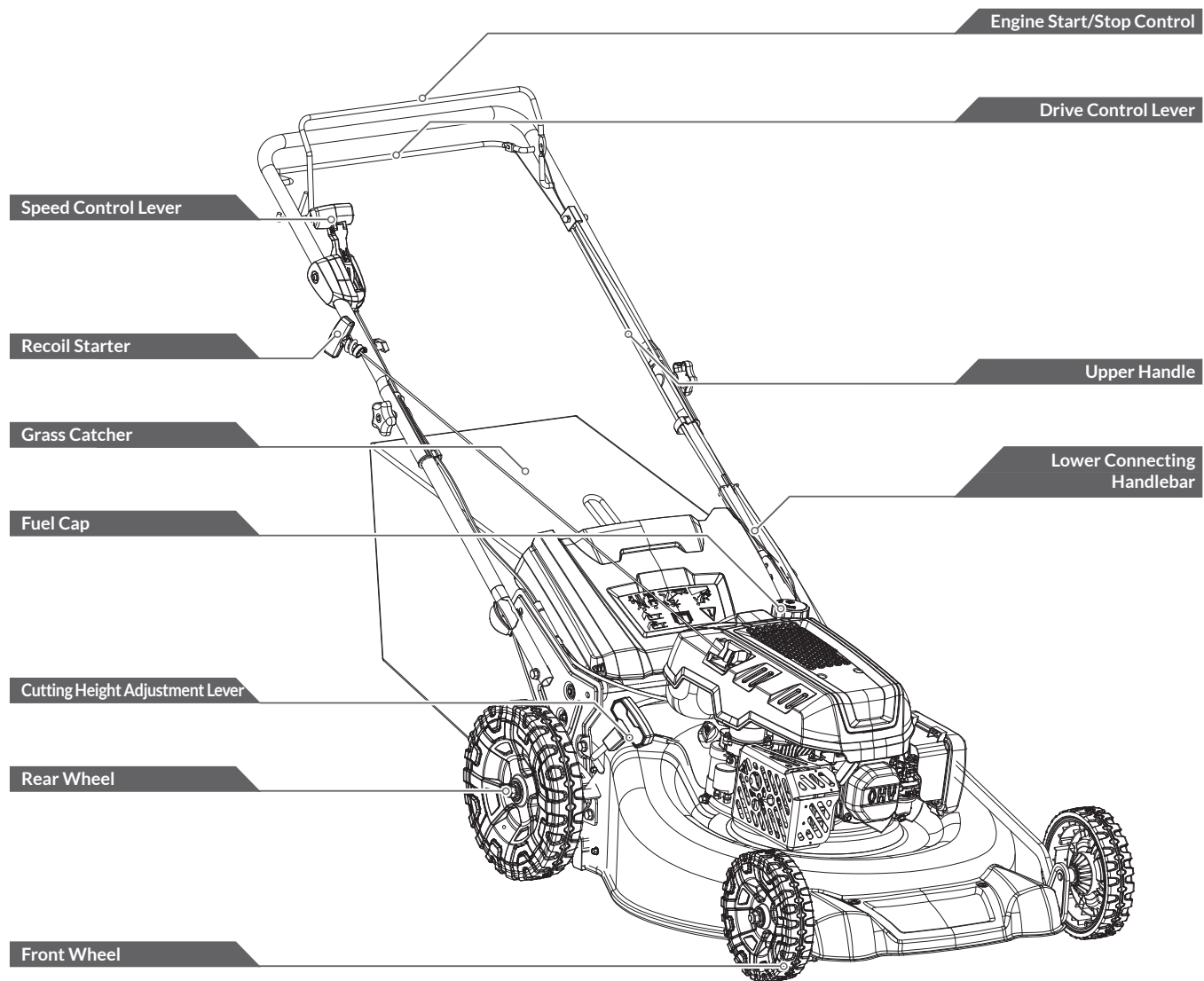

Figure 6



KNOW YOUR MACHINE

FEATURES AND CONTROLS



Engine Start/Stop Control

- » The engine start/stop control is attached to the upper handle of the mower. Depress and squeeze it against the upper handle to operate the unit. Release it to stop the engine and blade.

! WARNING *This engine start/stop control is a safety device. Never attempt to bypass its operation.*

Cutting Height Adjustment Lever

- » Move this lever to the desired position to change the cutting height.

Drive Control Lever

- » The drive control lever is located on the upper handle and is used to engage the drive. Pull the drive control lever against the handlebar to engage the drive, release it to disengage the drive.



Grass Catcher

- » Use the grass catcher to collect the grass clippings while you are operating the mower. Follow the instructions on page 12 in the Assembly section to attach the grass catcher.

Recoil Starter

- » The recoil starter is attached to the right upper handle. Stand behind the unit and pull the recoil starter rope to start the unit.

Speed Control Lever

- » Push the speed control hand toward the rabbit () to increase the speed, and push toward the turtle () to decrease the speed.

! WARNING *Before engaging the drive control lever, make sure the speed control is set at the lowest speed position ()*.

OPERATION



NOTE This unit is shipped without gasoline or oil in the engine. Be certain to service the engine with gasoline and oil as instructed in the Engine Operator's Manual before starting or running your machine.

ADDING OIL TO THE ENGINE

1. Make sure the lawn mower is on a flat, level surface.

2. Remove the oil fill cap/dipstick to add oil.

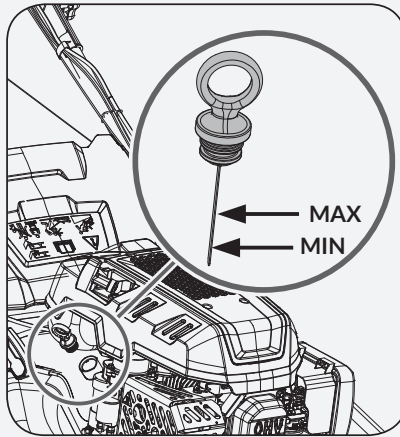

3. Using a funnel, add oil up to the **FULL** mark on the dipstick. (See engine manual for oil capacity, oil recommendation, and location of fill cap.)



CAUTION DO NOT OVERFILL. Check engine oil level daily and add as needed.

ADDING GASOLINE TO THE ENGINE



WARNING Gasoline is highly flammable and explosive. You can be burned or seriously injured when handling fuel. Use extreme care when handling gasoline.



WARNING Fill the fuel tank outdoors, never indoors. Gasoline vapors can ignite if they collect inside an enclosure. It can result in explosion.

1. The engine must be off and allowed to cool at least three minutes before adding fuel.
2. Remove the fuel filler cap and fill the tank. (See engine manual for fuel capacity, fuel recommendation, and location of the fuel cap.)



CAUTION IMPORTANT: DO NOT OVERFILL!

This equipment and/or its engine may include evaporative emissions control system components, required to meet EPA and/or CARB regulations, that will only function properly when the fuel tank has been filled to the recommended level. Overfilling may cause permanent damage to evaporative emissions control system components. Filling to the recommended level ensures a vapor gap required to allow for fuel expansion. Pay close attention while filling the fuel tank to ensure that the recommended fuel level inside the tank is not exceeded. Use a portable gasoline container with an appropriately sized dispensing spout when filling the tank. Do not use a funnel or other device that obstructs the view of the tank filling process.

3. Reinstall the fuel cap and tighten it. Always clean up spilled fuel.

CUTTING HEIGHT ADJUSTMENT

The cutting height can be adjusted to 7 different positions. Push the height adjustment lever forward for a lower cut. Pull the lever backward for a higher cut. Adjust cutting height to suit your requirements. The medium position is best for most lawns.



WARNING Adjusting the cutting height may bring you into contact with the moving blade, causing serious injury.

To set the cutting height, pull the height adjustment lever outward towards wheel, then, move it forward or backward to meet your desired cutting height. (See **Figure 7**)

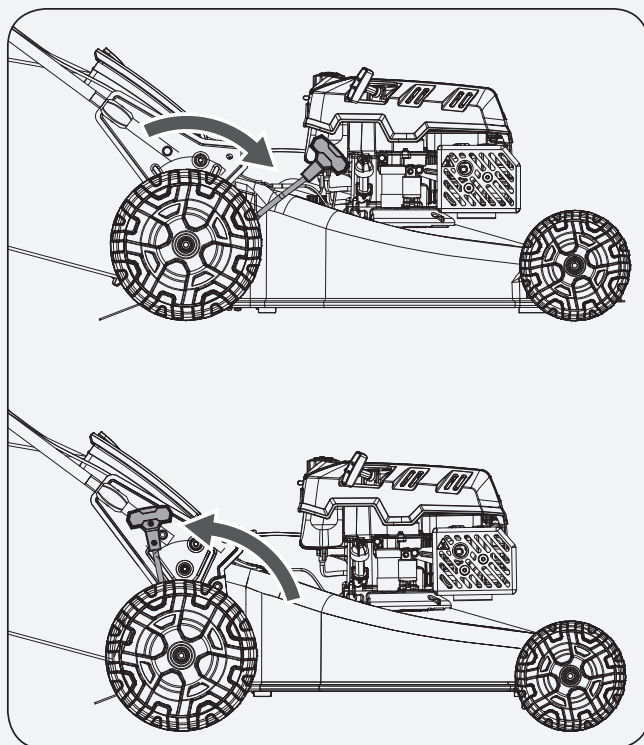

Figure 7

NOTE For rough or uneven lawns, move the height adjustment lever to a higher position. This will prevent you from cutting the grass too close to the ground.

BLADE CONTROL

WARNING Be sure no one other than the operator is standing near the lawn mower while starting the engine or operating the mower. Never run the engine indoors or in enclosed, poorly ventilated areas. Engine exhaust contains carbon monoxide, an odorless and deadly gas. Keep hands, feet, hair, and loose clothing away from any moving parts on the engine and lawn mower. Refer to the Engine Operator's Manual for detailed instructions on starting and stopping the engine.

1. Standing behind the mower, squeeze the engine start/stop control lever against the upper handle.

WARNING Rapid retraction of the starter cord (kickback) will pull your hand and arm toward the engine faster than you can let go. Broken bones, fractures, bruises, or sprains could result.

2. Holding the engine start/stop control lever firmly, grasp the recoil starter handle and pull the rope out with a rapid, continuous, full arm stroke. Keeping a firm grip on the starter handle, let the rope rewind slowly.
3. Pull the recoil starter until engine compression has become difficult to pull. Let the recoil return to the home position, then pull quickly to start the engine. Repeat steps as needed.

SELF PROPELLED

NOTE Once the engine is running and while using the mower, continue holding the engine start/stop control lever against the upper handle.

WARNING Before engaging the drive control lever, make sure the speed control is set at the lowest speed position (🐢).

1. Pull the drive control lever in the direction of the handlebar.
2. Push the speed control hand toward the rabbit (🐰) to increase the speed, and push toward the turtle (🐢) to decrease the speed.
3. Release the drive control lever to disengage the drive, for example when you go near an obstacle. (See **Figure 8**)

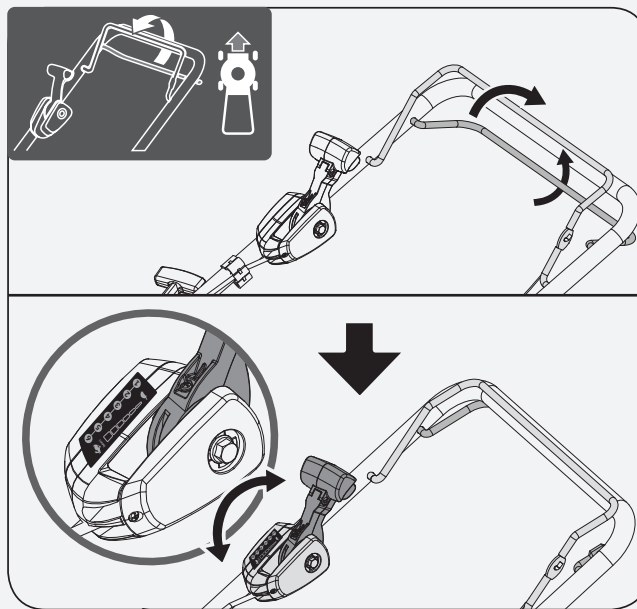

Figure 8

3 HANDLE HEIGHTS ADJUSTABLE

The three holes in the handle bracket are for three different handle heights. Quickly switch between the three holes by unlocking the knob, adjusting, and then releasing. (See **Figure 9**)

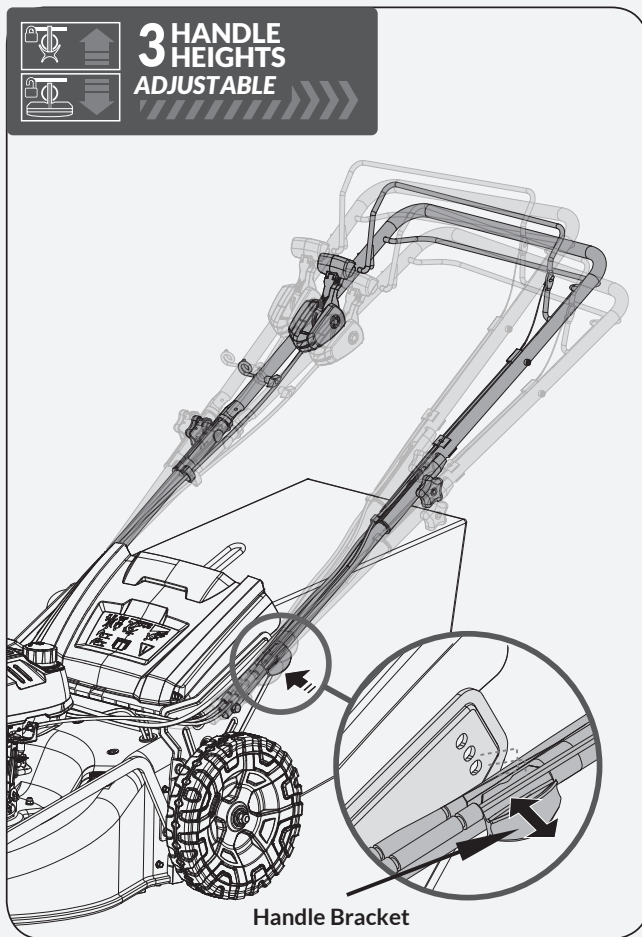

Figure 9

BASIC CUTTING PROCEDURE

- Always cut with a sharp blade for the best results. A blade that is not sharp cuts unevenly and lets the grass become yellow on the surface of the cut.
- Do not cut more than 1/3 of the length of the grass. This especially applies during dry periods. Cut first with the cutting height set high. Then examine the result and lower it to an applicable height. If the grass is too long, operate slowly and cut two times if necessary.



- For very heavy cutting, decrease the width of the cut by making an overlap of the cut path and cutting slowly.
- Cut in different directions each time to prevent stripes on the lawn.
- Regularly hose the grass catcher with water and let dry before use. Pores in cloth grass catchers can become filled with dirt and dust with the operation. The grass catcher will then collect less grass.

- The rear discharging mode of your product is the best cutting mode. If you try to cut a large quantity of grass and the product does not operate correctly, or has decreased operation time, change the product to rear discharging mode for better performance and operation time.

USING AS MULCHER

For mulching grass, ensure the mulch plug is installed on the product. For effective mulching, do not cut wet grass. If the grass has been allowed to grow in excess of four inches, mulching is not recommended.

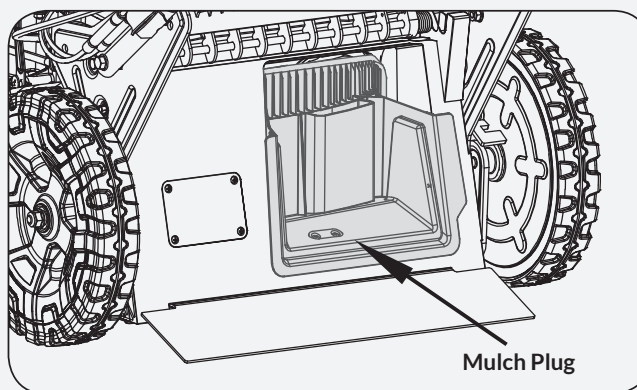

Figure 10

GRASS BAG COLLECTION MODE

Open the rear discharge door, remove the mulch plug and install the grass catcher. (See **Figure 11 & 12 & 13**)

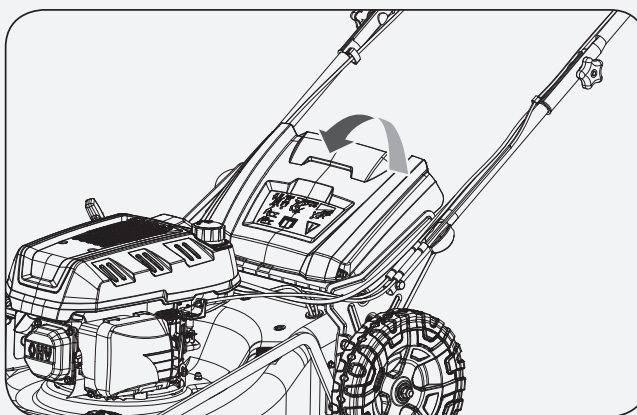

Figure 11

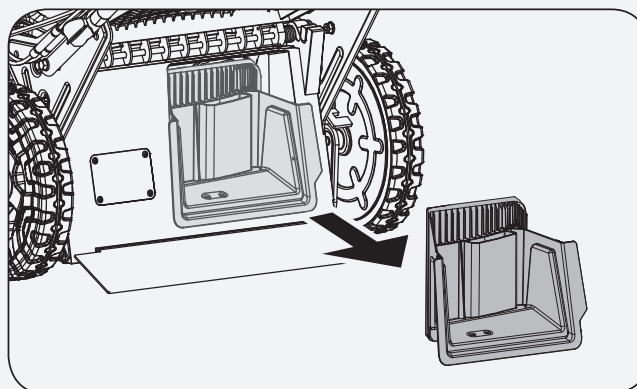

Figure 12

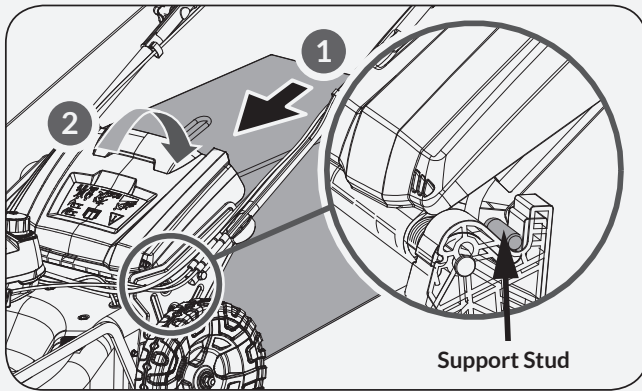

Figure 13

REAR DISCHARGE MODE

Remove both the mulch plug and grass catcher to enable rear discharge mode. (See **Figure 14 & 15 & 16**)

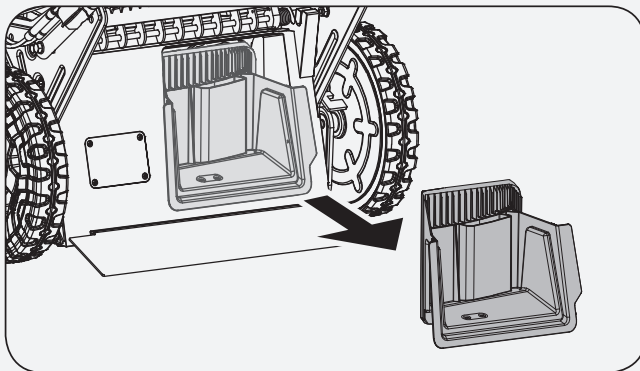

Figure 14

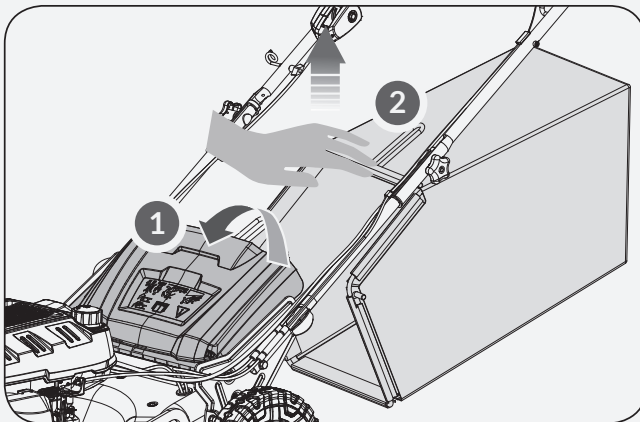

Figure 15

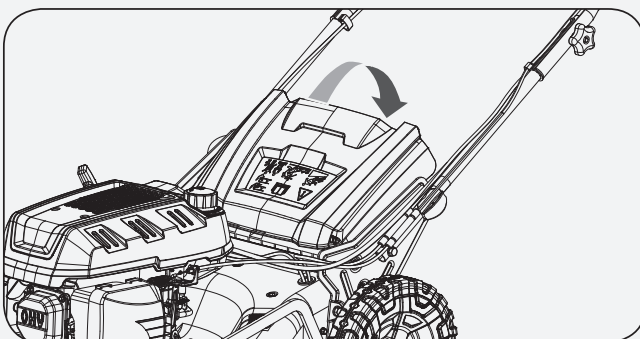

Figure 16

STOPPING THE MACHINE

Release the engine start/stop control lever to stop the engine and blade. (See **Figure 17**)

WARNING Wait for the blade to stop completely before performing any work on the mower.

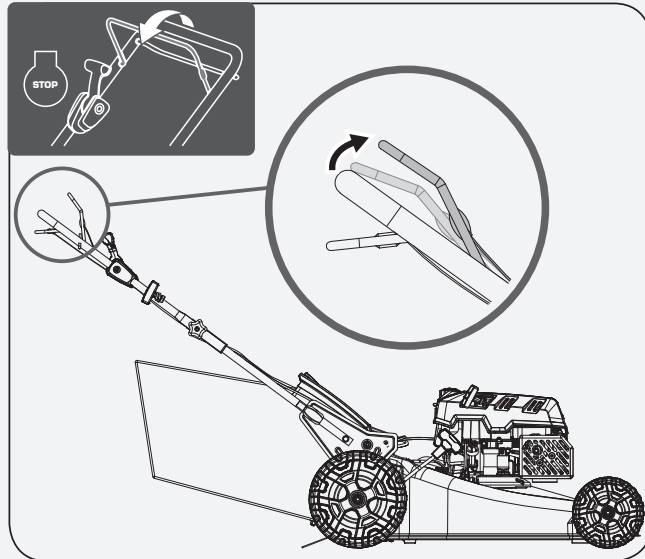

Figure 17

EMPTYING THE GRASS CATCHER

CAUTION Do not drag the bag when you empty the grass catcher to prevent wear.

1. Flip the rear discharge door up. (See **Figure 18, illustration 1**)
2. Lift the grass catcher with the frame handle. (See **Figure 18, illustration 2**)

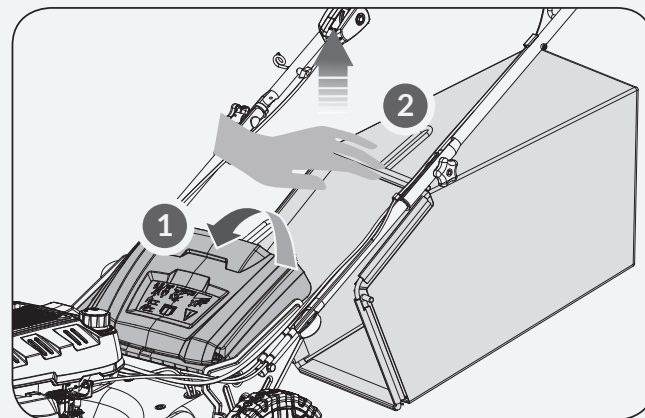

Figure 18

3. Remove grass clippings from the grass catcher from below the handle.
4. Empty grass clippings from the bag with the frame handle.

MAINTENANCE

MAINTENANCE SCHEDULE

In the maintenance schedule, you can see which parts of your machine require maintenance, and at which intervals it should take place. The intervals are calculated based on the average use of the machine and may differ depending on the rate of your personal use.

! WARNING Always stop the engine, allow the engine to cool, disconnect spark plug, and ground against the engine before performing any type of maintenance on your machine.

Interval	Item	Service
Before each use	1. Blade 2. Bolts and nuts	1. Check or replace 2. Check or tighten
Engine fails to start	1. Engine oil level 2. Loose or missing hardware 3. Air cleaner 4. Unit and engine 5. Bolts and nuts	1. Check 2. Tighten or replace 3. Check 4. Clean 5. Check or tighten
1st Month or 10 hours	1. Engine oil	1. Change
Annually or 25 hours	1. Air cleaner * 2. Control linkages/pivots and wheels 3. Underside of mower deck	1. Clean 2. Lube with light oil 3. Clean
Every 2 months or 20 hours	1. Belt Cover	1. Clean
Every 3 months or 30 hours	1. Engine oil	1. Change
Every 6 months or 50 hours	1. Spark plug 2. Air Cleaner	1. Replace 2. Replace
Before Storage	1. Fuel system	1. Run engine until it stops from lack of fuel, or add stabilizer to a full tank of fresh fuel prior to storage.

*Clean more often under dusty conditions or when airborne debris is present. Replace the air cleaner if very dirty.

GENERAL RECOMMENDATIONS

- Always observe safety rules when performing any maintenance.
- The warranty on this lawn mower does not cover items that have been subjected to operator abuse or negligence. To receive full value from the warranty, an operator must maintain the lawn mower as instructed here.
- Changing engine-governed speed voids the engine warranty.
- All adjustments should be checked at least once each season.
- Periodically check all fasteners and make sure these are tight.

LUBRICATION

1. Lubricate pivot points on the blade and drive controls at least once a season with light oil. These controls must operate freely in both directions. (See **Figure 19**)

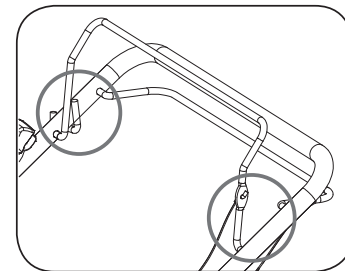

Figure 19

- The transmission is pre-lubricated and sealed at the factory and does not require lubrication.
- Follow the Engine Operator's Manual for lubrication schedule and instructions for engine lubrication.

DECK WASH

Your mower's deck is equipped with a female adapter on its surface as part of its deck wash system.

Use the deck wash to rinse grass clippings from the deck's underside and prevent the buildup of corrosive chemicals. Complete the following steps after each mowing:

- Push the mower to a level, clear location on your lawn, near enough for your garden hose to reach.
- Remove the grass catcher if attached. Close mulcher door.

NOTE Water, grass and other debris will drain from beneath the mower housing during the washout process.

WARNING Be sure the garden hose is not routed under the lawn mower housing or entangled in the wheels.

- Attach the garden hose with a male adapter (user supplied) to the female adapter on your deck's surface. (See **Figure 20**).

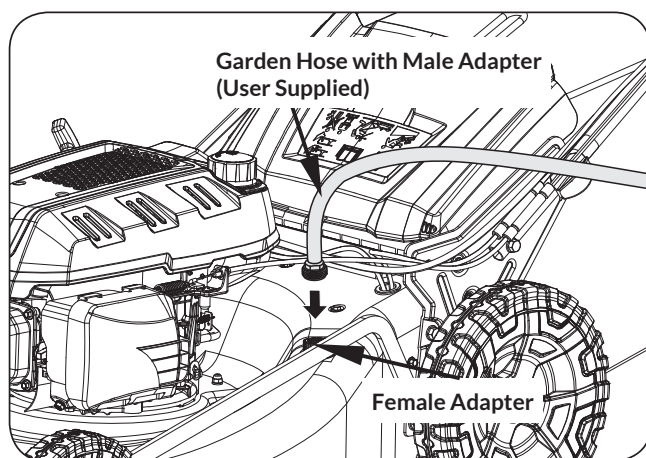

Figure 20

If your garden hose connector is a quick coupler type, follow the below steps to connect:

Remove the female adapter that is originally equipped on the deck, and replace it with the product adapter in the hardware plastic bag. Attach the garden hose with the quick coupler (user supplied) to the product adapter on your deck's surface. (See **Figure 21**).

YG4760PM02 - 2501

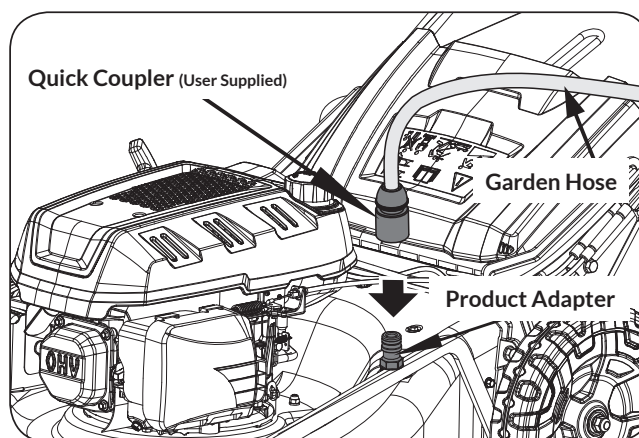

Figure 21

- Turn on the water supply and check for leaks.
- If no leaks are present, start the engine (as described in the Operation section of this manual) and let the engine run until the underside of the lawn mower is clean.

WARNING Do not engage the drive system during the washout process.

- Run the engine for a minimum of two minutes, allowing the underside of the cutting deck to thoroughly rinse.
- Release the engine start/stop control lever to stop the engine and blade.

WARNING Do not remove hose from fitting while engine is running. Water in engine can result in shortened engine life.

- Turn the water off and detach the quick coupler or adapter.
- After cleaning your deck, restart the mower. Keep the engine and blade running for a minimum of two minutes, allowing the underside of the cutting deck to thoroughly dry.

CLEANING THE BELT COVER

- Tip the machine onto its side with the air filter and carburetor facing up.

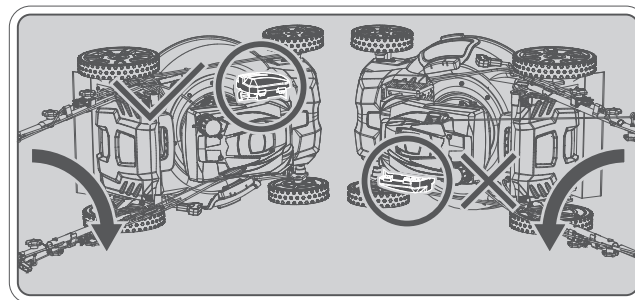

⚠ WARNING Always keep the air filter and carburetor facing up whenever needed to tip the machine onto its side.

2. Remove the blade. (See **Figure 22**)

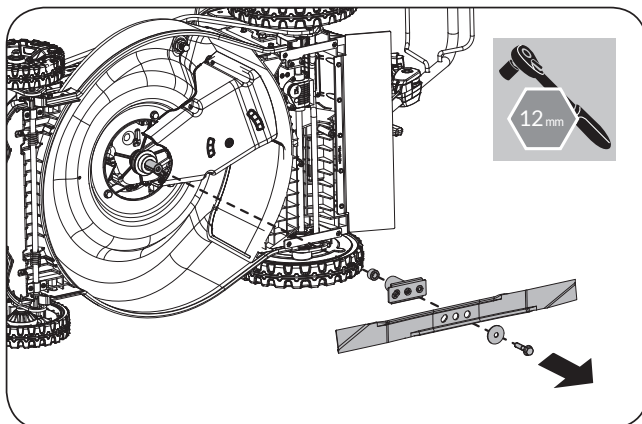

Figure 22

3. Remove the belt cover. (See **Figure 23**)

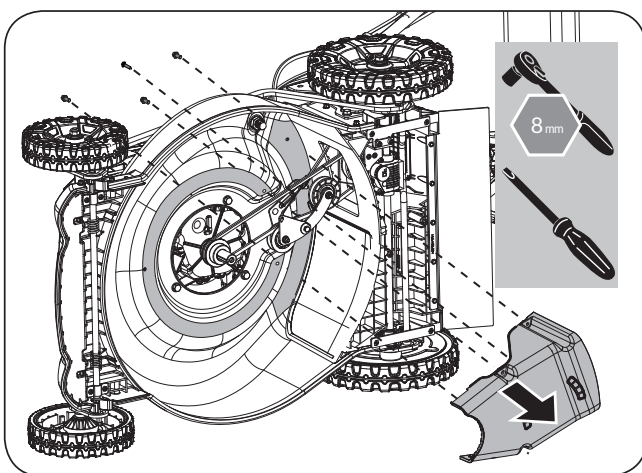

Figure 23

4. Use tools to clean soil and debris from the belt cover and around the tension roller plate.

ENGINE CARE

A list of key engine maintenance jobs required for good performance by the mower is listed below. Follow the Engine Operator's Manual for a detailed list and instructions.

- Maintain oil level as instructed in Engine Operator's Manual.
- Service air cleaner every 25 hours of use under normal conditions. Clean every few hours under extremely dusty conditions. Poor engine performance and flooding usually indicate that the air cleaner should be serviced. To service the air cleaner, refer to the Engine Operator's Manual.

- Clean spark plugs and reset the gap once a season. Spark plug replacement is recommended at the start of each mowing season. Check Engine Operator's Manual for correct plug type and gap specifications.
- Clean the engine regularly with a cloth or brush. Keep the top of the engine clean to permit proper air circulation. Remove all grass, dirt, and combustible debris from the muffler area.
- Engines stored between 30 and 90 days need to be treated with a gasoline stabilizer to prevent deterioration and gum from forming in the fuel system or on essential carburetor parts.

CLEANING THE GRASS CATCHER

Pores in cloth grass catchers can become filled with dirt and dust during operation. This causes the grass catcher to collect less grass. To prevent this, regularly hose the grass catcher off with water and let it dry before using.

- Examine the grass catcher frequently for wear or deterioration. Replace if necessary.

CHANGING THE ENGINE OIL

For more details about when to change the oil, see the Maintenance Schedule on page 19. To change the oil, use the following procedure.

NOTE Run the engine for a few minutes before changing the oil to warm it. Warm oil flows better and carries more contaminants. We recommend that you use API SERVICE Category SJ class or higher oil.

1. Move the machine to a level surface.
2. Refer to the maintenance safety section on page 9 before doing the oil change.
3. Remove the dipstick by rotating the cap counterclockwise and pulling it out. (See **Figure 24**)

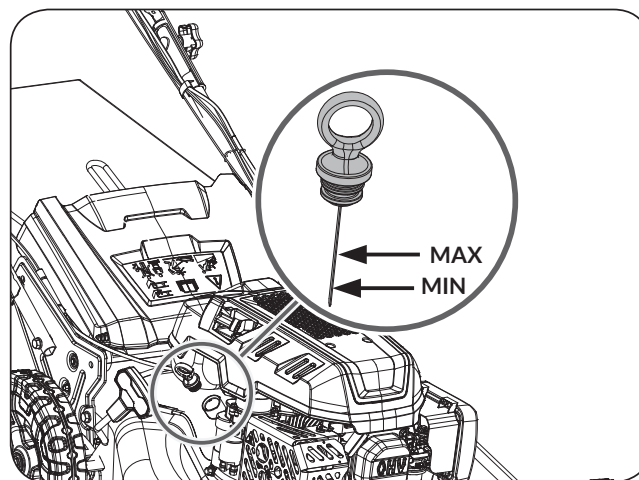
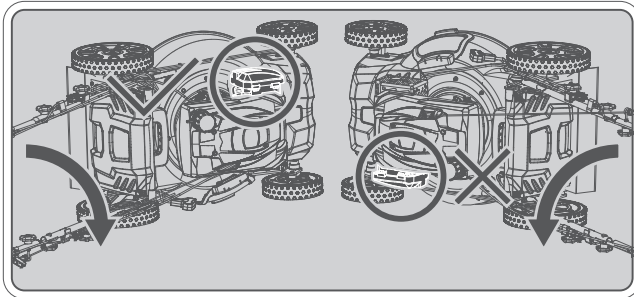

Figure 24

YG4760PM02 - 2501

- Tip the machine onto its side (so that the air filter is up) to drain the used oil from the oil-fill tube. (See **Figure 25**)



! WARNING Always keep the air filter and carburetor facing up whenever needed to tip the machine onto its side.

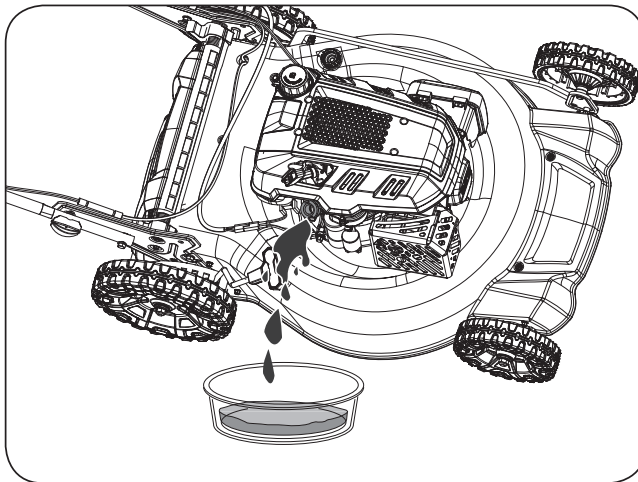

Figure 25

- After draining the used oil, return the machine to the operating position.
- Carefully pour about 3/4 of the engine capacity of oil into the oil-fill tube.
- Wait 3 minutes for the oil to settle in the engine.
- Wipe the dipstick clean with a clean cloth.
- Insert the dipstick into the oil-fill tube, then remove the dipstick.
- Read the oil level on the dipstick. (See **Figure 24**)
 - If the oil level on the dipstick is too low, carefully pour a small amount of oil into the oil-fill tube, wait 3 minutes, and repeat steps 8 through 10 until the oil level on the dipstick is correct.
 - If the oil level on the dipstick is too high, drain the excess oil until the oil level on the dipstick is correct.

! WARNING If the oil level in the engine is too low or too high and you run the engine, you may damage the engine.

- Install the dipstick into the oil-fill tube securely.
- Recycle the used oil properly.

BLADE CARE

! WARNING Always stop the engine before you do work on the blade. The blade continues to rotate after the throttle has been released. Make sure that the blade is fully stopped and disconnect the spark plug cap before you start work.

! WARNING The blade is sharp; contact with the blade can result in serious personal injury. Wear gloves when servicing the blade.

- Disconnect spark plug wire from spark plug and place wire where it cannot come in contact with plug. (See **Figure 26**)

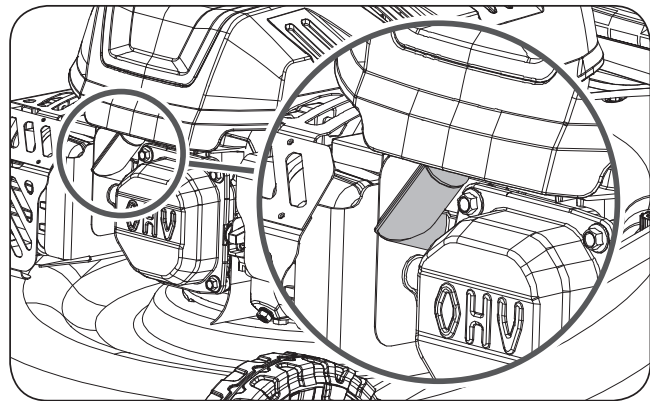
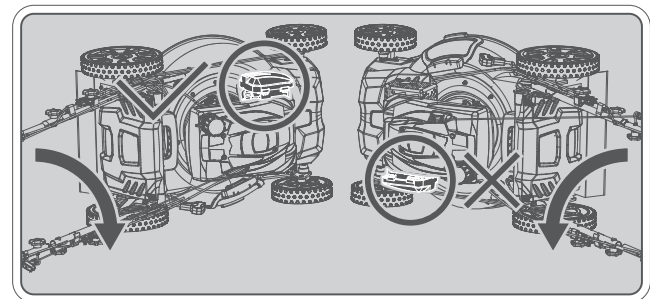

Figure 26

- Examine the blade whenever you run out of fuel. If the blade is damaged or cracked, replace it immediately. If the blade edge is dull or nicked, have it sharpened and balanced, or replace it.
- Tip the machine onto its side with the air filter and carburetor facing up. Use a block of wood to hold the blade steady. (See **Figure 27**)



WARNING Always keep the air filter and carburetor facing up whenever needed to tip the machine onto its side.

NOTE You will need a torque wrench to install the blade properly.

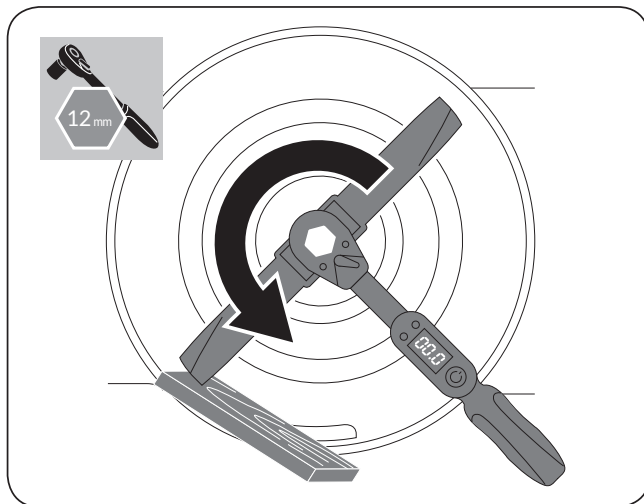

Figure 27

4. Remove the blade, saving all mounting hardware. Examine the blade support and blade bolt to see if there is damage. Examine the motor shaft to make sure that it is not bent. (See **Figure 28**)

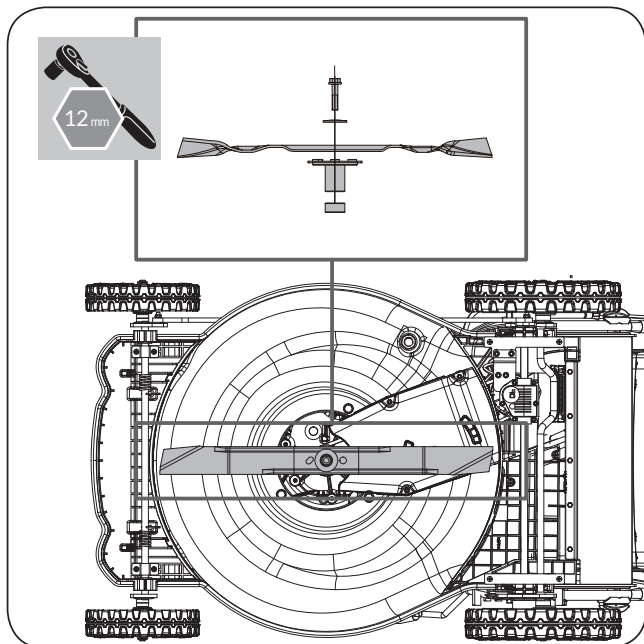

Figure 28

CAUTION Use only a replacement blade approved by the manufacturer of your mower. Using a blade not approved by the manufacturer of your mower is hazardous, could damage your mower and void your warranty.

WARNING Position the curved ends of the blade to point toward the machine housing.

5. Install the new blade. Use a block of wood between the blade and lawn mower housing and tighten the blade bolt, turning clockwise. The recommended tightening torque is 33.3-36.9 ft.-lb. (45-50 Nm). (See **Figure 29**)

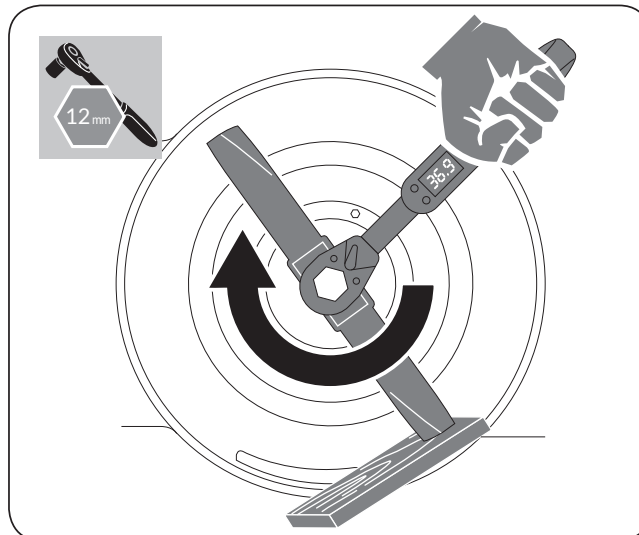

Figure 29

CAUTION To ensure safe operation of your mower, periodically check the blade bolt for correct torque.

NOTE Blade bolt is heat treated. If bolt needs replacing, replace only with approved bolt.

SPEED CONTROL ADJUSTMENT

When the drive starts feeling slow you need to adjust the speed control cable. See the below CABLE ADJUSTMENT section.

DRIVE CONTROL ADJUSTMENT

You will need to adjust the drive control cable if the mower doesn't propel itself with the drive control engaged. See the below CABLE ADJUSTMENT section.

ENGINE START/STOP CONTROL ADJUSTMENT

When depress the engine start/stop lever against the upper handle, and pull the recoil starter several times, the engine doesn't start, you must tighten the engine start/stop control cable. See the below CABLE ADJUSTMENT section. (See **Figure 30**)

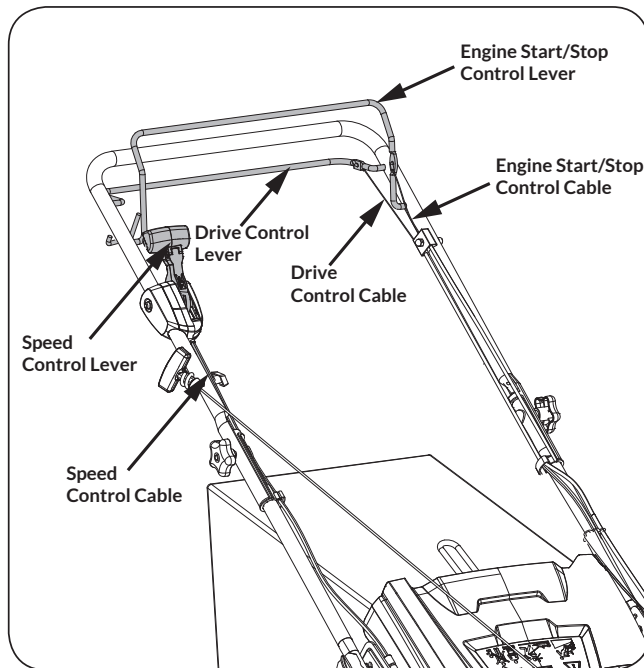

Figure 30

CABLE ADJUSTMENT

1. Loosen the jam nut. (See **Figure 31, Illustration 1**)
2. Rotate the turnbuckle to loosen or tight the cable. (See **Figure 31, Illustration 2**)
3. Tighten the jam nut. (See **Figure 31, Illustration 3**)

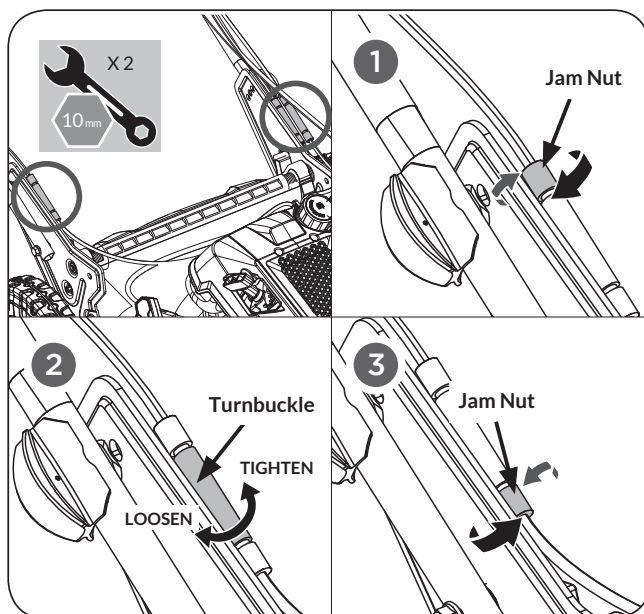
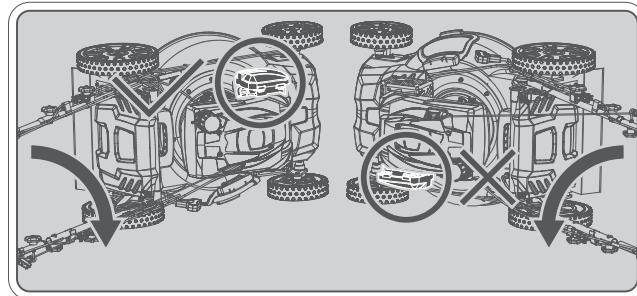

Figure 31

YG4760PM02 - 2501

BELT REPLACEMENT



WARNING Always keep the air filter and carburetor facing up whenever needed to tip the machine onto its side.

1. Remove the blade. (See **Figure 32**)

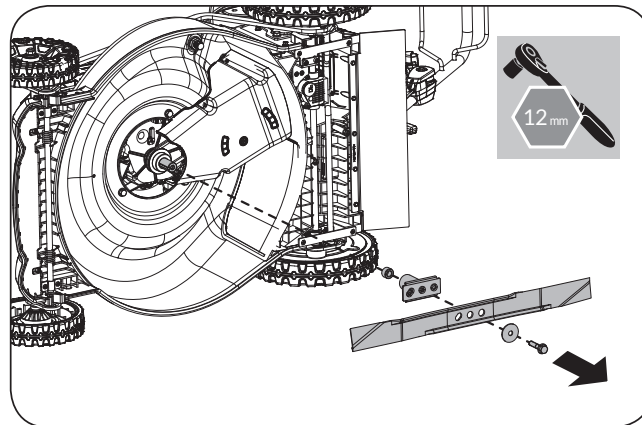

Figure 32

2. Remove the belt cover. (See **Figure 33**)

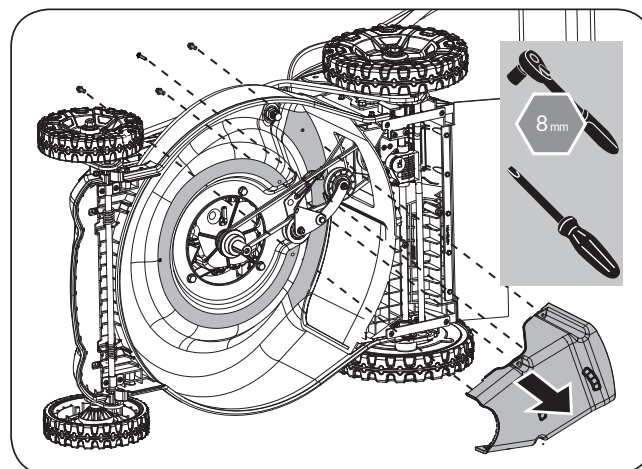

Figure 33

3. Remove the tension roller plate. (See **Figure 34, Illustration 1**)
4. Disconnect the cable from the tension roller plate. (See **Figure 34, Illustration 2**)

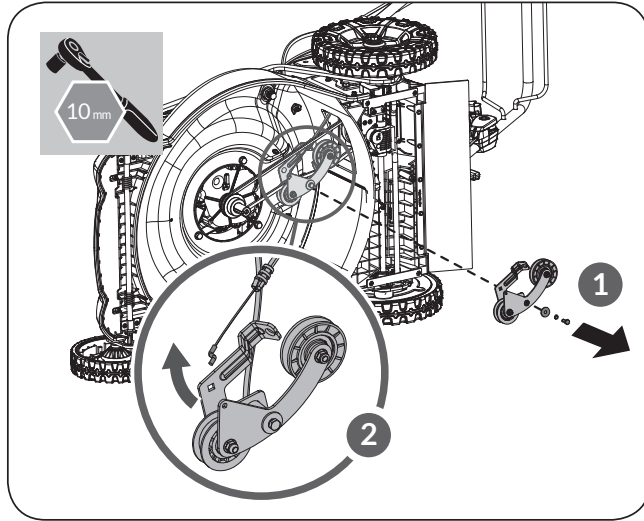
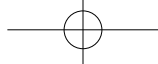

Figure 34

5. Remove the belt. (See **Figure 35**)

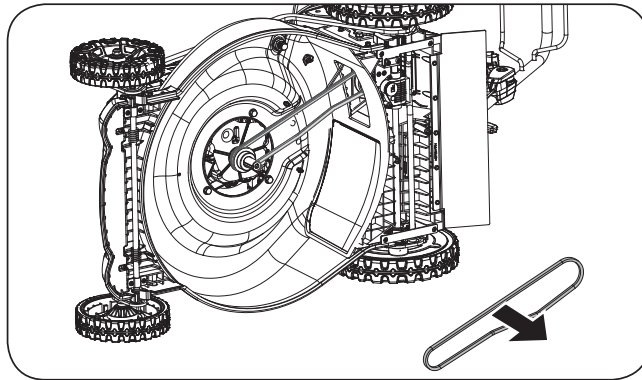

Figure 35

6. Assemble the new belt.

7. Assemble the machine in reverse order.

REPLACE THE WHEEL

1. Stop the engine and make the machine on a flat surface .

2. Remove the wheel nut and wheel from the wheel axle, using a 15 mm socket wrench. (See **Figure 36**)

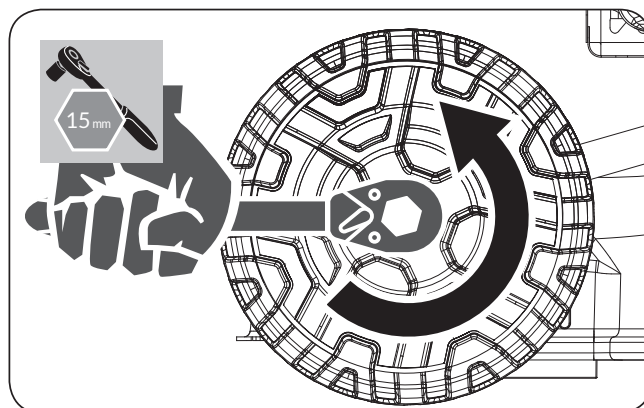

Figure 36

3. Assemble the new wheel with wheel nut. (See **Figure 37**)

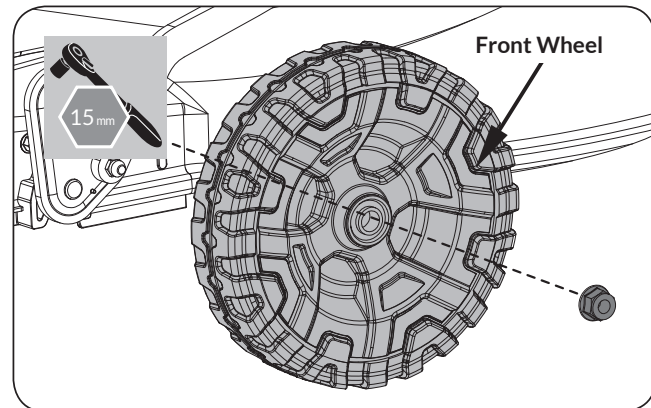

Figure 37

CAUTION Make ensure the inner gear ring of the wheel and the gear of the wheel guard are meshed in place.

4. Assemble the new wheel with wheel nut and washer. (See **Figure 38**)

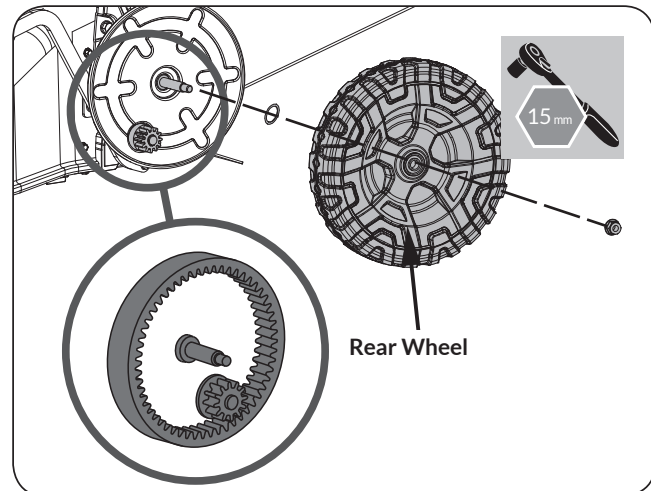

Figure 38

TRANSPORT AND STORAGE

The following steps should be taken to prepare your lawn mower for storage.

Keep all equipment safe during transportation to prevent damage and accidents.

For storage, keep equipment in a lockable area away from children and persons that are not approved. Do not store next to corrosive materials, such as fertilizer.

For storage, keep the product and equipment in a dry and frost-proof area.

When loading or moving the product, do not go more than the maximum recommended operation angle of 15 degrees.

Empty the fuel tank by operating the product until the tank is empty.

NOTE *Old fuel in the fuel tank is the leading cause of hard starting. Do not store fuel without fuel stabilizer more than 30 days, and do not store stabilized fuel more than 90 days.*

Remove the spark plug, pour a tablespoon (5-10 cc) of clean engine oil into the cylinder, and pull the starter rope slowly several times to distribute oil throughout the cylinder to prevent cylinder corrosion during the off-season. Loosely install the spark plug.

Drain the engine oil.

Clean the product.

Tighten bolts and nuts.

Replace or repair damaged components.

Touch up all rusted or damaged paint surfaces. Sand lightly before painting.

Use the correct protective cover on the product to keep it dry. Do not use plastic because it lets condensation collect and causes corrosion on the product.

NOTE *Clean and lubricate mower thoroughly as described in Maintenance section.*

NOTE *Apply a coat of chassis grease to mower's cutting blade to prevent rusting.*

NOTE *Refer to Engine Operator's Manual for the correct engine storage instructions.*

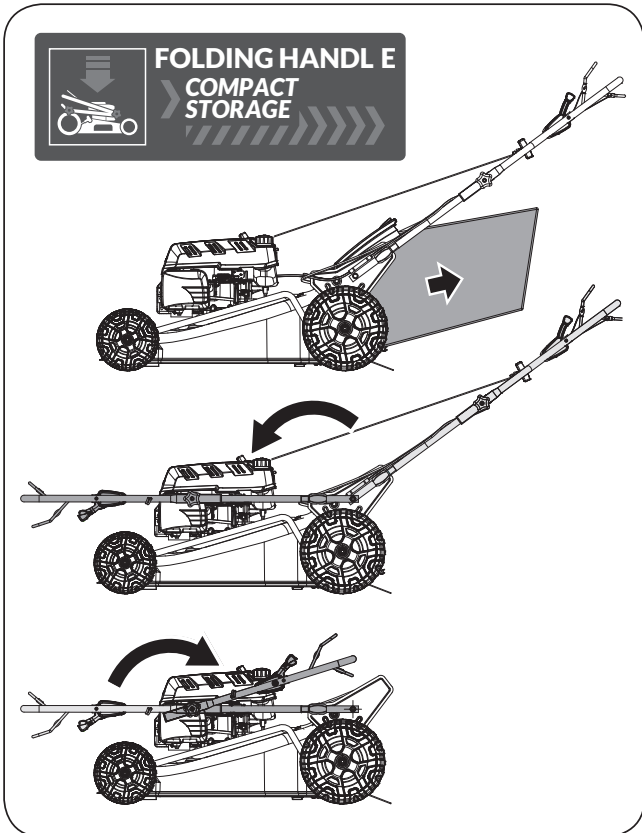

WARNING *Folding or unfolding the handle improperly can damage the cables, causing an unsafe operating condition.*

TROUBLESHOOTING

Problem	Cause	Remedy
The engine fails to start	<ol style="list-style-type: none"> 1. Blade control disengaged. 2. Spark plug boot disconnected. 3. Fuel tank empty or stale fuel. 4. Engine not primed (If equipped with primer). 5. Faulty spark plug. 6. Engine flooded. 	<ol style="list-style-type: none"> 1. Engage blade control. 2. Connect the wire to spark plug boot. 3. Fill tank with clean, fresh gasoline. 4. Prime engine as instructed in the Operation section of the Engine Manual. 5. Clean, adjust gap or replace. 6. Wait a few minutes to restart.

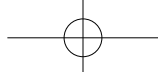

Problem	Cause	Remedy
Hard to start or blowing white smoke	Air filter, carburetor and spark plug polluted by oil and gas spilled from tipping on the incorrect side.	Replace air filter. Clean carburetor and spark plug.
Engine runs erratic	<ol style="list-style-type: none"> 1. Spark plug boot loose. 2. Stale fuel. 3. Vent in gas cap plugged. 4. Water or dirt in the fuel system. 5. Dirty air cleaner. 6. Blocked fuel line. 	<ol style="list-style-type: none"> 1. Connect and tighten the spark plug boot. 2. Fill tank with clean, fresh gasoline. 3. Clear vent. 4. Run the engine until it stops from lack of fuel. Refill with fresh fuel. 5. Refer to Air Cleaner Maintenance in the Engine Manual. 6. Contact your Parts & Repair Center to have the fuel line cleaned.
Engine overheats	<ol style="list-style-type: none"> 1. Engine oil level low. 2. Air flow restricted. 	<ol style="list-style-type: none"> 1. Fill crankcase with proper oil. 2. Clean the area around and on top of the engine.
Idles poorly	<ol style="list-style-type: none"> 1. Spark plug fouled, faulty, or gap too wide. 2. Dirty air cleaner. 	<ol style="list-style-type: none"> 1. Reset gap or replace the spark plug. 2. Refer to Air Cleaner Maintenance in the Engine Manual.
Excessive vibration	<ol style="list-style-type: none"> 1. Cutting blade loose or unbalanced. 2. Bent cutting blade. 	<ol style="list-style-type: none"> 1. Tighten blade and adapter. Balance blade. 2. Replace blade.
The mower will not mulch grass	<ol style="list-style-type: none"> 1. Wet grass. 2. Excessively high grass. 3. Dull blade. 	<ol style="list-style-type: none"> 1. Do not mow when the grass is wet; wait until dry to cut. 2. Mow once at a high cutting height, then mow again at desired height or make a narrower cutting path. 3. Sharpen or replace the blade.
Uneven cut	<ol style="list-style-type: none"> 1. Buildup of grass, leaves, and debris under mower. 2. Dull blade. 	<ol style="list-style-type: none"> 1. Clean the underside of mower housing. 2. Sharpen or replace the blade.
Grass catcher not filling	<ol style="list-style-type: none"> 1. Cutting height too low. 2. Worn blade. 3. Catcher not venting air. 	<ol style="list-style-type: none"> 1. Raise height of cut. 2. Replace the blade. 3. Clean / inspect grass catcher.
Mower will not self propel	<ol style="list-style-type: none"> 1. Belt not installed properly. 2. Debris clogging speed control system. 3. Damaged or worn belt. 4. Drive control out of adjustment. 5. Damaged transmission box or transmission box speed control wheel. 6. Broken Speed Adjustment Cable. 7. Damage or jamming of the tension roller. 	<ol style="list-style-type: none"> 1. Check belt for proper pulley installation and movement. 2. Stop engine, disconnect spark plug boot, and see page 20 to clean out debris from the belt cover. 3. Inspect and, if necessary, see page 24 to have belt replaced. 4. Adjust drive control. Refer to page 23. 5. Contact customer service. 6. Replace Speed Adjustment Cable. 7. Replace the tension roller.

PARTS DIAGRAM

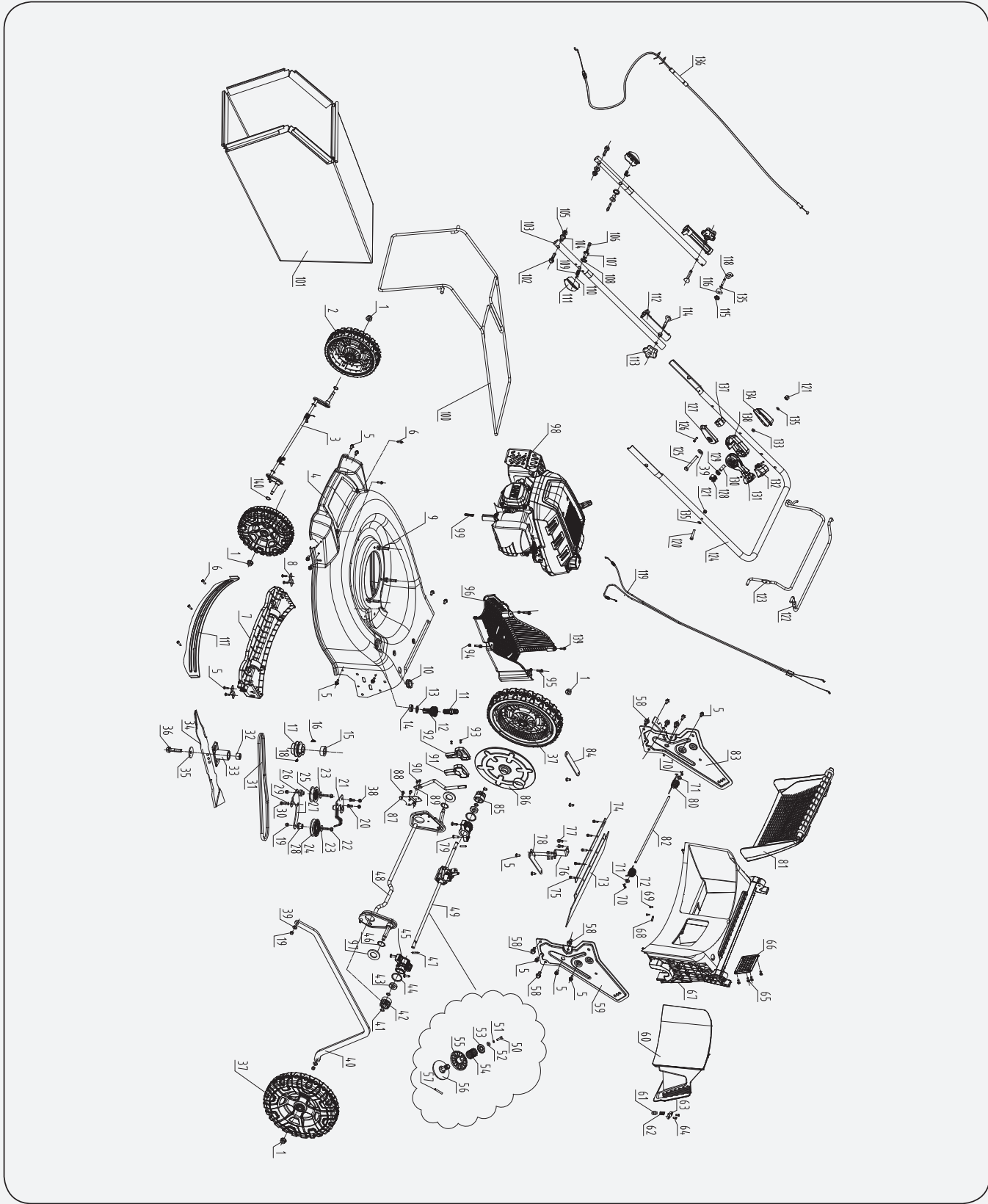

33245V02

YG4760 PARTS LIST

No.	Description	Qty	No.	Description	Qty
1	Lock Nut M10	4	40	Height Adjustment Connecting Rod	1
2	Wheel	2	41	Retaining Ring 12	4
3	Front Wheel Axle	1	42	Left Gear	1
4	Cutting Deck	1	43	Ball Bearing R8ZZ	2
5	Hexagon Head Self-tapping Screw ST6.3x19C	22	44	Sealing O-Ring	2
6	Cross Recessed Tapping Screw ST4.8x19C	5	45	Shaft Bushing	2
7	Front Deck Guard	1	46	Waveform Elastic Washer 23x29x0.5	2
8	Guard Mounting Base	2	47	Pin 5x25-YH	2
9	Bolt M8x25	3	48	Rear Wheel Axle	1
10	Silicone Wire Sleeve	1	49	Transmission Box	1
11	Product Adapter	1	50	Screw M5x16	1
12	Water Port	1	51	Spring Washer 5	1
13	Washer 16	1	52	Big Washer 5	1
14	Hex Nut M16	1	53	Speed Regulating Spring Holder	1
15	Engine Pulley Washer	1	54	Speed Regulating Spring	1
16	Woodruff Key 4x6.5x16	1	55	Sliding Belt Pulley Assembly	1
17	Engine Pulley	1	56	Fixed Belt Pulley Assembly	1
18	Screw M6x8	1	57	Elastic Pin 5x35	1
19	1# Hexagon Lock Nut M6	4	58	Bolt M8x16	6
20	Half Round Head Square Neck Bolt M6x16	2	59	Left Handle Bracket	1
21	Cable Fastening Plate	1	60	Mulch Plug	1
22	Flange Bolt M6x30	2	61	Cover Fastening Pin	1
23	Big Washer M6	3	62	Upper Handle Spring	1
24	Pulley	1	63	Cover Plate	1
25	Belt Blocking Pulley	1	64	Cross Recessed Tapping Screw ST4.8x9.5F	2
26	Step Shaft I	1	65	Cross Recessed Tapping Screw M5x12	4
27	Pulley Mounting Plate	1	66	Rear Deck Mounting Plate	1
28	Step Shaft II	1	67	Rear Deck	1
29	Spring Washer M6	1	68	Wire Clamp Plate	1
30	Bolt M6x16	1	69	Cross Recessed Tapping Screw M4x16	2
31	V-Belt Z940LA	1	70	Pin 2x11x35	2
32	Bushing	1	71	Flat Washer 8	2
33	Blade Support Seat	1	72	Left Torsion Spring	1
34	Blade	1	73	Shield- Trailing	1
35	Spring Washer for Blade	1	74	Shield Trailing Plate	1
36	Flange Bolt 3/8-24UNF_L=40	1	75	Hexagon Head Self-tapping Screw ST5.5x19F	5
37	Rear Wheel	2	76	Transmission Box Retaining Plate	1
38	Hexagon Flange Lock Nut M6	2	77	Hexagon Socket Head Screw M6x12	4
39	Big Washer 6	3			

No.	Description	Qty
78	Transmission Box Protection Plate 2	1
79	Cross Recessed Tapping Screw ST6.3x25	4
80	Right Torsion Spring	1
81	Rear Discharge Cover	1
82	Rear Cover Shaft	1
83	Right Handle Bracket	1
84	Transmission Box Protection Plate 2	1
85	Right Gear Assembly	1
86	Rear Wheel Cover	2
87	Flexible Plate	1
88	Screw M6x10	3
89	Height Adjustment Handlebar	1
90	Flat Head Rivet 5x10	2
91	Lower Handle Box	1
92	Upper Handle Box	1
93	Cross Recessed Tapping Screw With Washer M3x12(ST2.9x12)	2
94	Hexagon Flange Lock Nut M5	3
95	Hex Flange Bolt M5x16	3
96	Belt Cover	1
97	Flat Washer 22	2
98	Engine	1
99	Flat Key 4.78X4.78X	1
100	Grass Bag Holder	1
101	Grass Bag	1
102	Hex Flange Bolt M8x35	2
103	Lower Connecting Handlebar	2
104	Shaft Bushing	2
105	Hexagon Metal Flange Lock Nut M8	2
106	Positioning Pin	2
107	Positioning Pin Bushing	2
108	Plastic Seat	2
109	Spring	2
110	Elastic Pin 2x12	2
111	Unlock Knob	2
112	Insulating Sleeve	2
113	Wing Knob	2
114	Curved Round Head Bolt M8x55	2
115	Lock Nut M6	1
116	Fastening Gasket	1
117	Front Baffle	1
118	Rope Guide	1

No.	Description	Qty
119	Engine Start Cable+Stop Control Cable	1
120	Screw M6x35	1
121	Cap Nut	2
122	Drive Control Lever	1
123	Engine Start/Stop Control Lever	1
124	Upper Handle	1
125	Bolt M6x70	1
126	Cross Recessed Tapping Screw ST2.9x9.5	1
127	Speed Control Lever Holder-Left Cover	1
128	Ratchet Wheel	1
129	Compression Spring	1
130	Spacer Bush	1
131	Speed Control Lever	1
132	Lever Cover	1
133	Nut M6	1
134	Speed Control Lever Holder-Right Cover	1
135	Flat Washer 6	2
136	Speed Adjustment Cable	1
137	Cable Clamp	3
138	Speed Control Lever Holder	1
139	Cross Recessed Tapping Screw ST5.5x19F	1
140	Waveform Elastic Washer 20.5x14.5x0.3	2

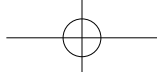

yardmax.com

Tame the Great Outdoors®



847-327-0566 or 844-YARDMAX | support@yardmax.com