

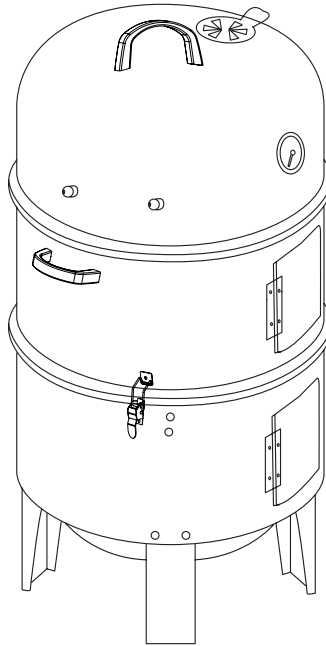

INSTRUCTION MANUAL

BARREL SMOKER MODEL NO. CSM-16



PLEASE RETAIN THIS INSTRUCTION MANUAL FOR FUTURE REFERENCE.



Price Zone dba
International

COMMERCE, CA 90040
SUPPORT@GASONE.COM
TOLL FREE: 1.800.698.5070
CUSTOMER SERVICE HOURS:
M-F: 9 AM-5 PM PST

FOR CALIFORNIA CONSUMERS ONLY:



WARNING

CANCER AND REPRODUCTIVE HARM.
GO TO WWW.P65WARNINGS.CA.GOV

**FOR VIDEO INSTRUCTIONS, SCAN
QR CODE USING A SMART CAMERA**



TABLE OF CONTENTS

| | |
|----------------------|---|
| WARRANTY INFORMATION | 2 |
| WARNINGS | 3 |
| OPERATION | 4 |
| PARTS LIST | 5 |
| ASSEMBLY | 7 |

WARRANTY INFORMATION

LIMITED WARRANTY

GASONE warrants that for the period of one year this product, will be free from defects in material and workmanship. GASONE, at its option, will repair or replace this product or any component of the product found to be defective during the warranty period. Replacement will be made with a new or remanufactured product of component. If the product is no longer available, replacement will be made with a similar product of equal or greater value. This is your exclusive warranty. This warranty is valid for the original retail purchaser from the date of initial retail purchase and is not transferable. Keep the original sales receipt. Proof of purchase is required to obtain warranty performance. GASONE dealers, service centers, or retail stores selling GASONE products do not have the right to alter, modify or in any way change the terms and conditions of this warranty.

This warranty does not cover normal wear of parts or damage resulting from any of the following: negligent use or misuse of the product, use contrary to the operating instructions, disassembly, repair or alteration by anyone other than GASONE or an authorized service center. Further, the warranty does not cover acts of God, such as fire, flood, hurricanes and tornados.

GASONE shall not be liable for any incident or consequential damages caused by the breach of any express or implied warranty or conditions. Except to the extent prohibited by applicable law, any implied warranty of merchantability or fitness for a particular purpose is limited in duration to the duration of the above warranty or conditions. Some states, provinces or jurisdictions do not allow the exclusion or limitation of incidental or consequential damages or limitations on how long an implied warranty lasts, so the above limitations or exclusion may not apply to you. This warranty gives you specific legal rights, and you may also have other rights that vary from state to state or province to province. How to obtain warranty service: do not return this product to the store. Call 1(800) 698-5070 or write us at GASONE, 6211 Randolph St. Commerce, CA 90040. Be prepared to give your name, address, model number, description of the problem, phone number, and proof of retail purchase (sales slip).

DISCLAIMERS

Apart from the warranty and disclaimers as described in this warranty statement. There are explicitly no further warranty or voluntary declarations of liability given here which go beyond the statutory liability applying to us.

The present warranty statement also does not limit or exclude situations or claims. Where we have mandatory liability as prescribed by statute.

You assume the risk and liability for loss, damage, or injury to you and your property and/or others and their property arising out of the misuse or abuse of the product or failure to follow instruction in the accompanying owner's manual.

This warranty applies to private single family home or apartment use only and does not apply to grills used in commercial, communal, or multi-unit settings such as restaurants, hotels, resorts, or rental properties.

We may from time to time change the design of its products. Nothing contained in this warranty shall be construed as obligating to incorporate such design changes into previously manufactured products. Nor shall such changes be construed as an admission that previous designs were defective. This product is intended FOR OUTDOOR USE ONLY. DO NOT use indoors.

- **WARNING: ALWAYS** keep children and pets away from the product when in use.
- **NEVER** leave a burning fire unattended.
- **DANGER** of carbon monoxide poisoning - **NEVER** light this product or let it smoulder or cool down in confined spaces.
- **DO NOT** use this product in a tent, caravan, car, cellar, loft or on a boat.

WARNINGS

The smoker must only be used outdoors and must be placed firmly on a solid, even and not combustible surface shielded from wind.

- **WARNING:** Any modification of this unit can be dangerous.
- **WARNING:** Only use this smoker outdoors in a well-ventilated area. Do not use in a garage, building, or any enclosed area.
- **WARNING:** Do not use the smoker within 1 m (3 ft) of combustible materials.
- **WARNING:** The entire cooking unit gets hot when in use. Do not leave unattended.
- **WARNING:** Keep the cooking area clear of flammable vapors and liquids such as gasoline, alcohol, etc. and combustible materials. Do not place the smoker near entrances, doorways, or in thoroughfares. Never move the smoker while it is hot.

OPERATION









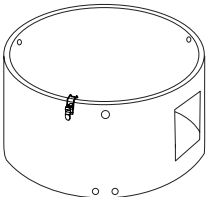
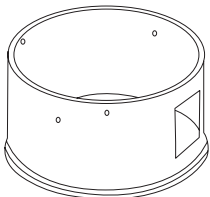
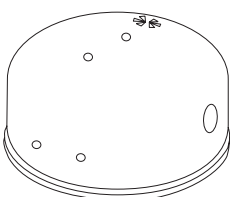
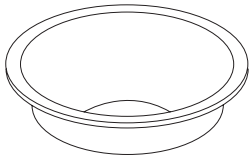
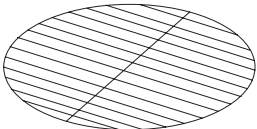

CURING YOUR SMOKER

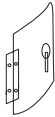
1. Before first use and after cleaning, apply a light coat of vegetable oil or vegetable cooking spray to the interior surface of the dome lid, smoker body, cooking grills and water pan. This simple process will help reduce the interior rusting. DO NOT apply oil to the charcoal pan.
2. Charcoal lighting fluid must be allowed to burn off prior to closing dome lid (approximately 20 minutes). Failure to do this, could trap fumes from charcoal lighting fluid in smoker and may result in a flash fire or explosion when lid is opened.
3. With coals burning hot in charcoal pan, close dome lid.









LIGHTING

1. Remove dome lid, upper layer body, water pan, cooking grills, and set aside.
2. Make sure the charcoal pan is resting securely on the notched out step of all three legs.
WARNING: Never use charcoal that has been pre-treated with lighter fluid. Use only high grade plain charcoal or charcoal/wood mixture.
3. Use charcoal lighting fluid approved for lighting charcoal ONLY. Do not use gasoline, kerosene or alcohol for lighting charcoal. Place 8-10 pounds of high quality charcoal in charcoal pan.
4. Saturate charcoal with lighting fluid and wait 2 to 3 minutes for fluid to soak in. Store charcoal lighting fluid safely away from the smoker.
5. Carefully light the charcoal and allow to burn until covered with a light ash prior to closing and door and placing upper layer body and dome lid on smoker. This will allow charcoal lighting fluid to burn off.
6. Dried aromatic wood chips or chunks should be saturated with water, so that when placed directly on hot charcoal briquets, a smoldering smoke will result.
7. Place the upper layer body on top of the lower layer body. Place water pan on the support brackets of the lower layer body. Make sure water pan is resting securely on notched out step of all three support brackets.
8. Carefully fill water pan with warm water or marinade to 1" below the rim. A full pan holds 4 quarts/1 gallon of water and will last 2-3 hours. Do not overfill and allow water to overflow from water pan.
9. Place a cooking grill on the lower support brackets directly on top of the water pan.
10. Place food on the cooking grill in a single layer with space between each piece. This will allow smoke and moist heat to circulate evenly around all pieces.
11. Place the other cooking grill on the upper support brackets of the upper layer body, position the grill so the rim resting securely on notched out step of all three support brackets. Place food on the cooking grill.
12. Place the dome lid on smoker body and allow food to cook.

PARTS LIST

| | | | |
|--|---|---|--|
| <p>A Lower Body 1 pc</p>  | <p>B Upper Body 1 pc</p>  | <p>C Dome Lid 1 pc</p>  | <p>D Charcoal Pan and Water Pan 2 pc</p>  |
| <p>E Cooking Grill 2 pc</p>  | <p>F Charcoal Grate 1 pc</p>  | <p>G Leg 3 pc</p>  | <p>H Door 2 pc</p>  |
| <p>I Air Vent 1 pc</p>  | <p>J Handle 3 pc</p>  | <p>K Lock Bracket 3 pc</p>  | <p>L Support Bracket 6 pc</p>  |
| <p>M Iron Support 2 pc</p>  | <p>N S Hook 3 pc</p> <p>2</p>  | <p>O Thermometer 1 pc</p>  | |

PARTS LIST (CONT.)

| Diagram | Ref.# | Qty | Diagram | Ref.# | Qty |
|---|-----------|-----|---|--------|-----|
|  | AA: M6X12 | 6 |  | EE: M6 | 6 |
|  | BB: M5X10 | 7 |  | FF: M5 | 7 |
|  | CC: M4X10 | 7 |  | GG: M3 | 7 |
|  | DD: M6 | 6 |  | HH: M6 | 4 |
| | | |  | II: M6 | 6 |

ASSEMBLY

STEP 1: Attach 3 legs (G) to lower body (A) using 6 x bolts (AA) & 6 x nuts (EE). Then attach door (H) to lower body (A) using 2 x bolts (CC) & 2 x nuts (GG).

 AA: 6pcs

 EE: 6pcs

 CC: 2pcs

 GG: 2pcs

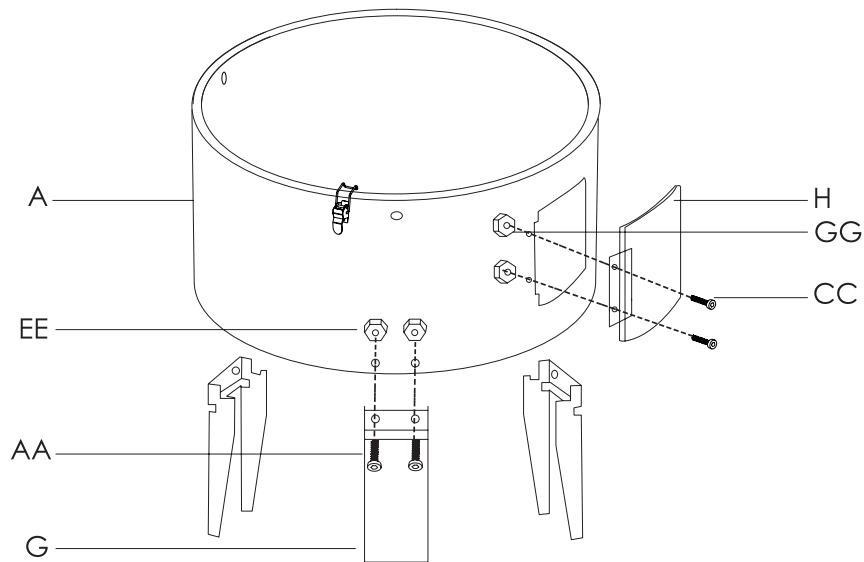

STEP 2: Place charcoal grate 1 x (F) and charcoal pan (D) to the bottom of the lower body bowl. Attach support brackets 3 x (L) to the lower body fire bowl using 3 x (BB), nuts 3 x (FF). Place water pan 1 x (D) and cooking grill 1 x (E) on support brackets.

 BB: 3pcs

 FF: 3pcs

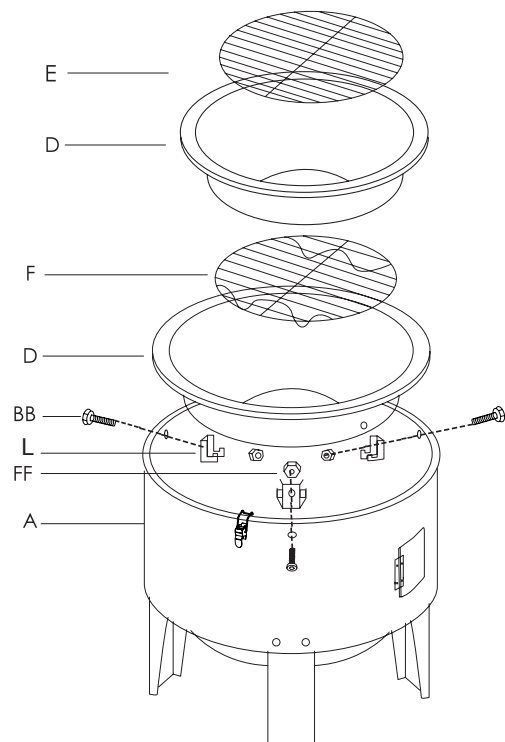

STEP 3: Attach handle 2 x (J) to the upper body bowl 1 x (B) using bolts 4 x (II), and washer 4 x (DD). Attach door (H) to the upper body bowl 1 x (B) using bolts 2 x (CC), and nuts 2 x (GG).

 CC: 2pcs

 GG: 2pcs

 DD: 4pcs

 II: 4pcs

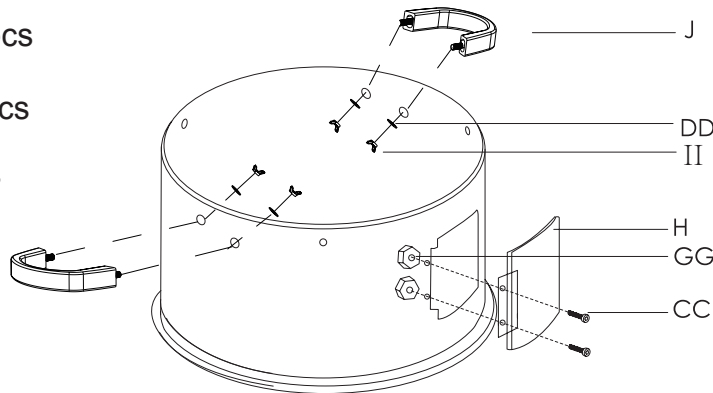

STEP 4: Assemble support brackets 3 x (L) to the upper body bowl using bolts 3 x (BB), nuts 3 x (FF). Assemble lock brackets 3 x (K) to upper body bowl using bolts 3 x (CC) and nuts 3 x (GG). Place cooking grill 1 x (E) on support brackets.

 BB: 3pcs

 FF: 3pcs

 CC: 3pcs

 GG: 3pcs

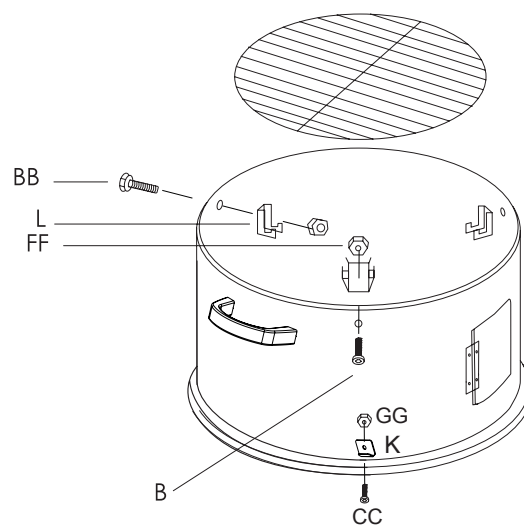

ASSEMBLY

STEP 5: Attach lid handle 1 x (J) to the dome lid (C) using 2 x washers (DD) and 2 x nuts (II). Attach air vent 1 x (I) to the lid using 1 x bolt (BB) and 1 x nut (FF). Attach thermometer 1 x (O) to the lid using the pre-assemble bolt and nut. Attach iron support 2 x (M) to dome lid (C) using 2 x (HH).

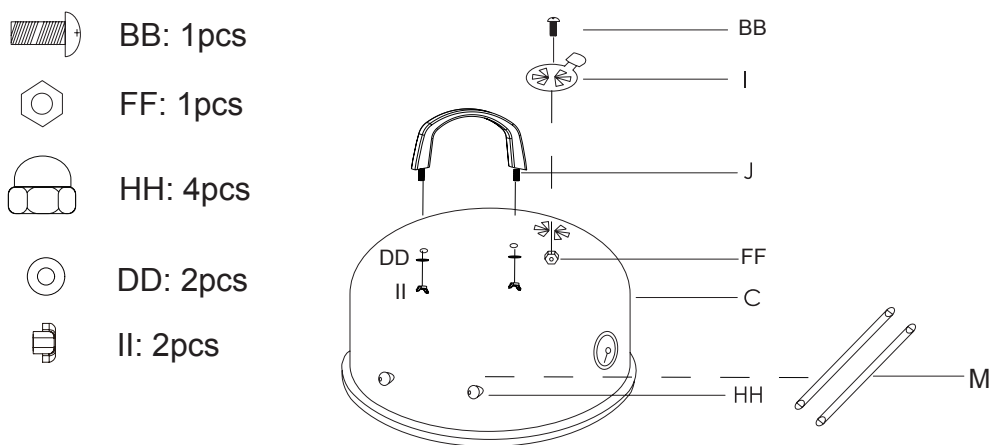

STEP 6: Place the lid in the product.

