

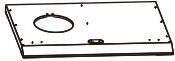























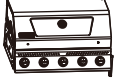

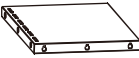
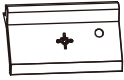















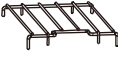



No.	#	QYT / CANT. / QTÉ	Description / Descripción / Description	Image / Imagen / Image
1	05-WXL-20	4	Caster Rueda Roulette	
2	AJDB03H5B	1	Bottom shelf Estante inferior Etagere inferieure	
3	AJQPGDZ01	1	Screw bushing Buje del perno de fijación de la bombona Douille de vis	
4	07-QPG-05-SI	1	LP cylinder screw Perno de fijación de la bombona Vis de bouteille de gaz	
5	AJCBL02	1	Left panel Panel izquierdo Panneau gauche	
6	AJCBR02	1	Right panel Panel derecho Panneau droit	
7	AJHB025B	1	Rear panel Panel trasero Panneau arrière	
8	AJQPDG015B	1	LP cylinder barrier bar Barra de seguridad para la bombona de gas Barre de barrière de bouteille de gaz	
9	AJSJJQPL02	1	Triangle support plate (L) Placa de soporte triangular (I) Plaque de support triangulaire (G)	
10	AJSJJQPR02	1	Triangle support plate (R) Placa de soporte triangular (D) Plaque de support triangulaire (D)	
11	AJQHL02H5B	1	Cart front beam Barra frontal del carro Poutre avant du chariot	
12	EJMGDPL01	1	Beam connector (L) Unión de la barra (I) Connecteur de faisceau (G)	
13	EJMGDPR01	1	Beam connector (R) Unión de la barra (D) Connecteur de faisceau (D)	
14	AJQPGB01-DS1	1	Thermal baffle Deflector térmico Panneau isolant	
15	AJML025B	1	Cabinet door (L) Puerta del armario (I) Porte d'armoire (G)	
16	AJMR025B	1	Cabinet door (R) Puerta del armario (D) Porte d'armoire (D)	
17	04-GBS-2-02-200-PG	2	Door handle Tirador de la puerta Poignée de la porte	

No.	#	QYT / CANT. / QTÉ	Description / Descripción / Description	Image / Imagen / Image
18	04-BSZ-03-BK	4	Handle sleeve Base de encastre del tirador Manche de poignée	
19		1	Main body Cuerpo principal Corps principal	
20	AB30GRB	1	Side burner thermal baffle Deflector térmico de quemador lateral Panneau isolant de bruleur d'appoint	
21	AB30BLL01+ AB30BLG	1	Side burner shelf Base del quemador lateral Etagère du bruleur d'appoint	
22	AT30CTR01	1	Side table Mesa lateral Table d'appoint	
23	AB30ZSJ02H- SS4	1	Side burner decoration board Panel decorativo del quemador lateral Panneau de décoration du bruleur d'appoint	
24	AT30ZSJR02H- SS4	1	Side table decoration board Panel decorativo de la mesa lateral Panneau de décoration de la table d'appoint	
25	ATZJL01	1	Side burner support plate Placa de sujeción del quemador lateral Plaque de support du bruleur d'appoint	
26	ATZJR01	1	Side table support plate Placa de sujeción de la mesa lateral Plaque de support de table d'appoint	
27	06-XNZ-6-01	1	Knob base Base de mando de regulación de llama Base du bouton	
28	06-XNL-6-06- BK-RGC	1	Knob Mando de regulación de llama Bouton	
29	01-LTL-4-10- 234-F-SS4	1	Side burner Quemador lateral Bruleur d'appoint	
30	ALJYP015B-DS2	1	Grease tray Bandeja de recogida de grasa Lèchefrite	
31	ALYPZJR02	1	Grease tray bracket (R) Fijación de Bandeja de recojida de grasa (D) Support du Lèchefrite (D)	
32	ALYPZJL02	1	Grease tray bracket (L) Fijación de Bandeja de recojida de grasa (I) Support du Lèchefrite (G)	
33	TY-YB01-LS4	1	Grease cup Depósito de recogida de grasa Bac à graisse	
34	ALFHB01-SS4	4	Flame tamer Regulador de llama Atténuateur de flamme	

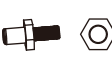
No.	#	QYT / CANT. / QTÉ	Description / Descripción / Description	Image / Imagen / Image
35	ALFHB02-SS4	1	Flame tamer (big) Regulador de llama (grande) Gros atténuateur de flamme	
36	03-ZTW-A-01-TC4	1	Cooking grate (big) Rejilla para asar (grande) Gros grille de cuisson	
37	03-ZTW-A-02-TC4	1	Cooking grate Rejilla para asar Grille de cuisson	
38	03-ZTW-A-03-TC4	1	Sear grate Rejilla para marcar la carne Grille de marquage de la viande	
39	03-BWW-A-01-5B-DD1	1	Warming rack Rejilla para calentar Grille de réchauffement	
40	03-GJL-04-TC3	1	Side burner grate Rejilla del quemador lateral Grille du bruleur d'appoint	
41	04-GBS-2-54-600-PG	1	Lid handle Manija de la tapa Poignée du couvercle	

No.	#	Image / Imagen / Image	No.	#	Image / Imagen / Image
A	M6x12	 x46	G	M5	 x1
B	M5x10	 x31	H	Washer Arandela Rondelle	 x2
C	M4x8	 x6	I	M6x20	 x2
D	M4x10	 x4	J	Stud with nut Espárrago con tuerca integrada Goujon avec écrou	 x4
E	Magnet Imán Aimant	 x1	K	M5x10	 x12
F	Washer Arandela Rondelle	 x6	L	Washer Arandela Rondelle	 x2

**TOOLS REQUIRED / HERRAMIENTAS REQUERIDAS / OUTILS REQUIS**

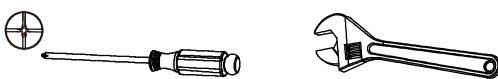
Description / Descripción / Description		Image / Imagen / Image
Phillips screwdriver Destornillador phillips Tournevis phillips	Wrench Llave Clé	

Before beginning assembly, make sure all parts are present. If any parts are missing or damaged, do not attempt to assemble the products. Contact customer service for replacement parts via telephone or email.

- Tools needed (not included): Phillips screwdriver and wrench
- Approximate assembly time: 70 minutes
- Note: 1. The right and left sides of the grill are designed as if you are facing the front of the grill.  
2. Model shown for illustration purpose only, specific please in kind prevail.

Antes de comenzar el montaje, asegúrese de que todas las piezas estén presentes. Si falta alguna pieza o está dañada, no intente ensamblar los productos. Póngase en contacto con el servicio de atención al cliente para obtener piezas de repuesto por teléfono o correo electrónico.

- Herramienta necesaria (no incluido): Destornillador phillips y llave
- Tiempo aproximado de ensamblaje: 70 minutos
- Nota: 1. Los lados derecho e izquierdo de la parrilla están diseñados como si estuvieras frente a la parte delantera de la parrilla.  
2. El modelo que se muestra es sólo para fines ilustrativos, prevalecen los específicos en especie.

Avant de commencer l'assemblage, assurez-vous que toutes les pièces sont présentes. Si des pièces sont manquantes ou endommagées, n'essayez pas d'assembler les produits. Contactez le service de clientèle pour les pièces de rechange par téléphone ou par e-mail.

- Outils nécessaires (non inclus): Tournevis phillips et clé
- Temps nécessaire pour l'assemblage: 70 minutes
- Remarque: 1. les côtés droit et gauche du gril sont conçus comme si vous faisiez face à l'avant du gril.  
2. le modèle est présenté à des fins d'illustration uniquement, spécifiques en nature prévalent.

**1** A  ×16

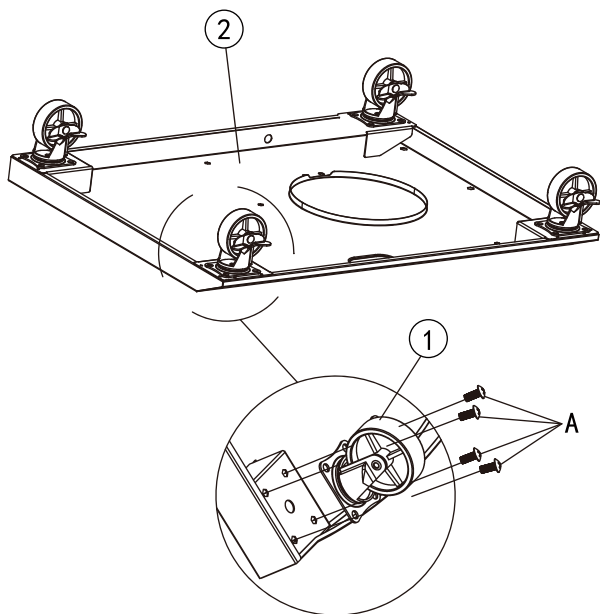

**2** A  ×2

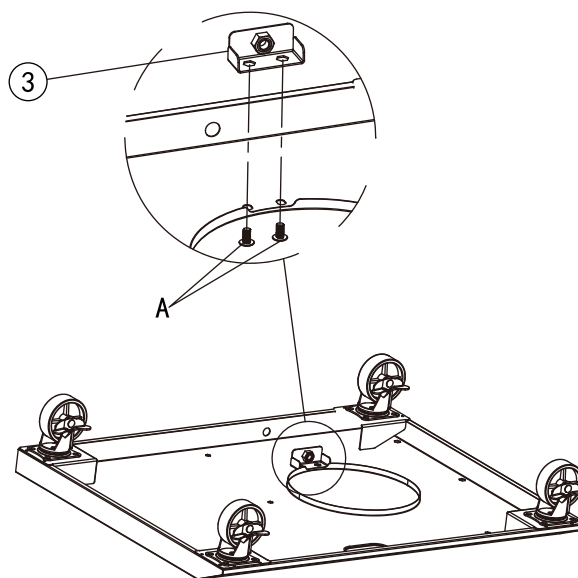

**3**

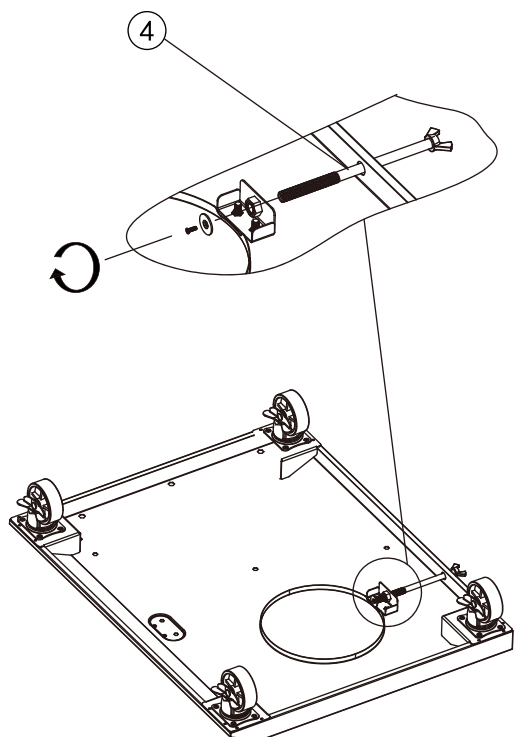

**4** B  ×4

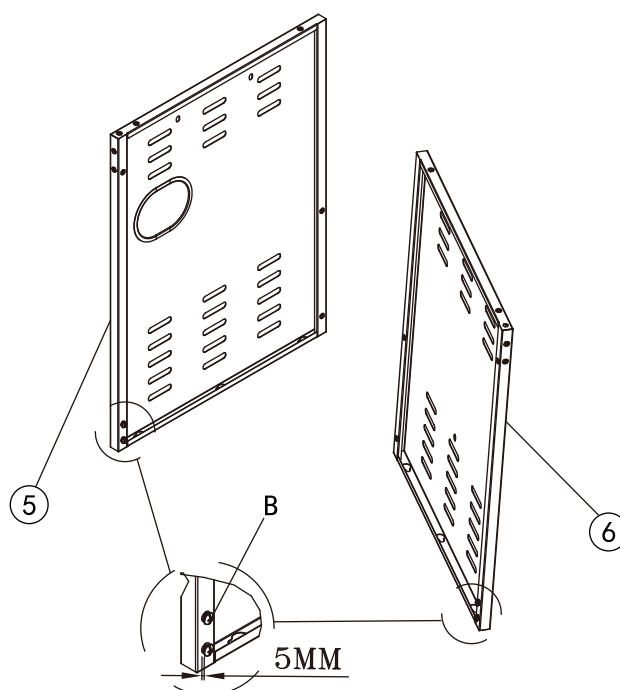

- Do not secure the bolts until step 7.
- No apretar las tornillos hasta el paso 7.
- Ne pas fixez les boulons avant l'étape 7.





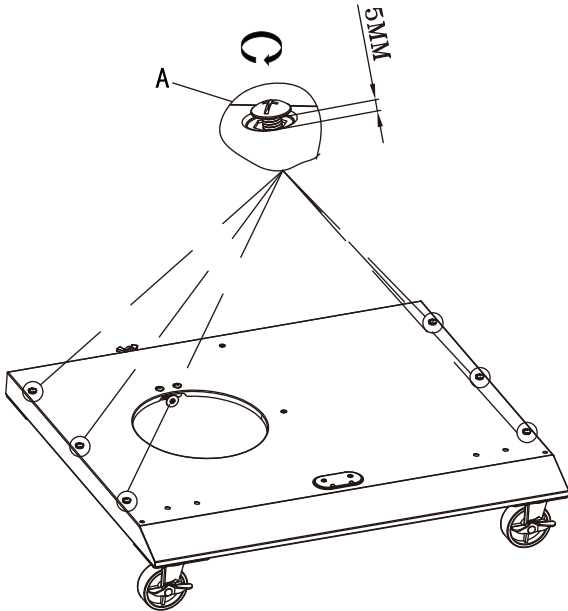

<b>5</b>	A		×6
----------	---	---	----

- Do not secure the bolts until step 7.
- No apretar las tornillos hasta el paso 7.
- Ne pas fixez les boulons avant l'étape 7.

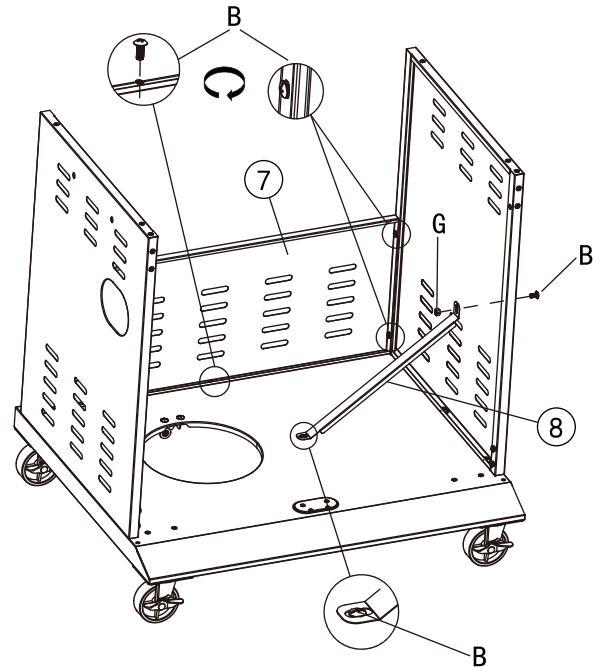

<b>6</b>	B		×7
	G		×1



<b>7</b>	B		×4
	C		×2
	E		×1

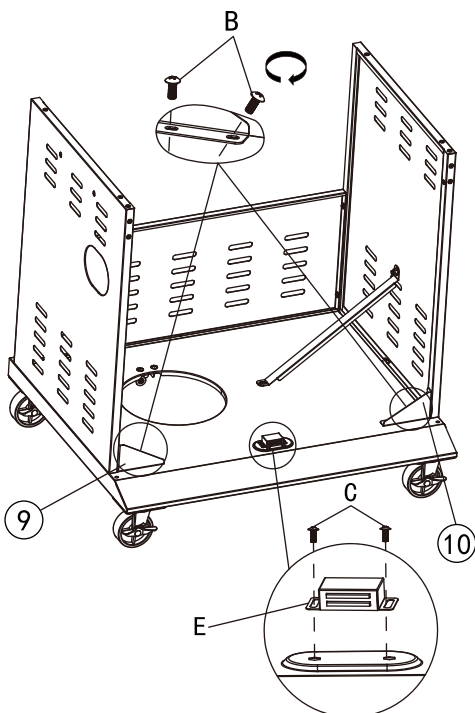

<b>8</b>	K		×8
----------	---	--	----

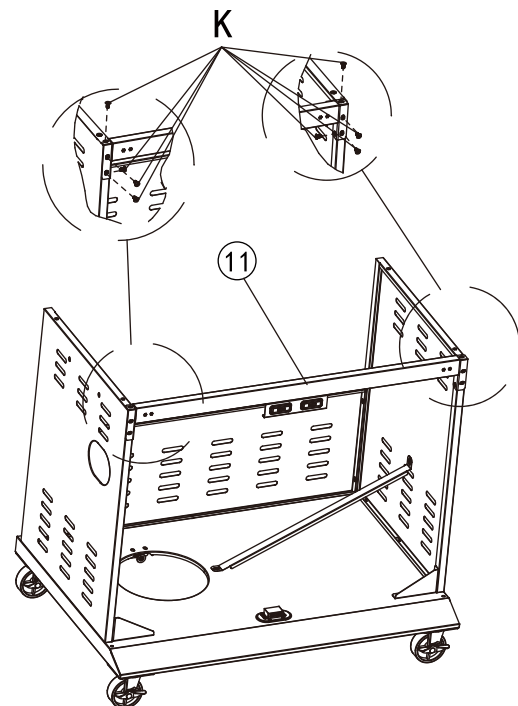

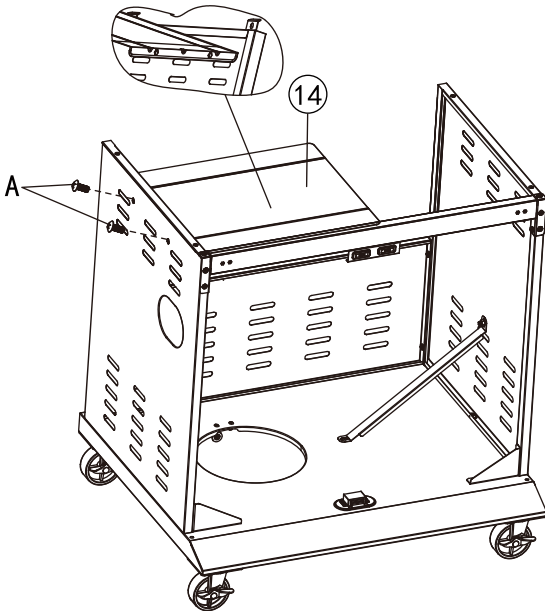

**9** A  ×2

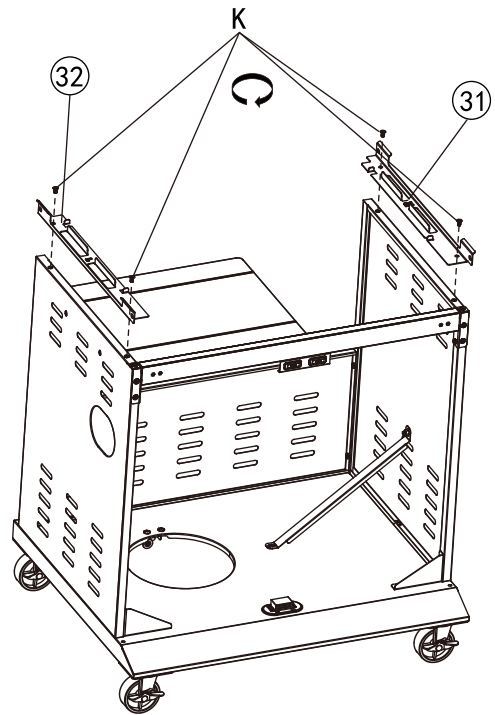

**10** K  ×4



**11** A  ×4  
J  ×4

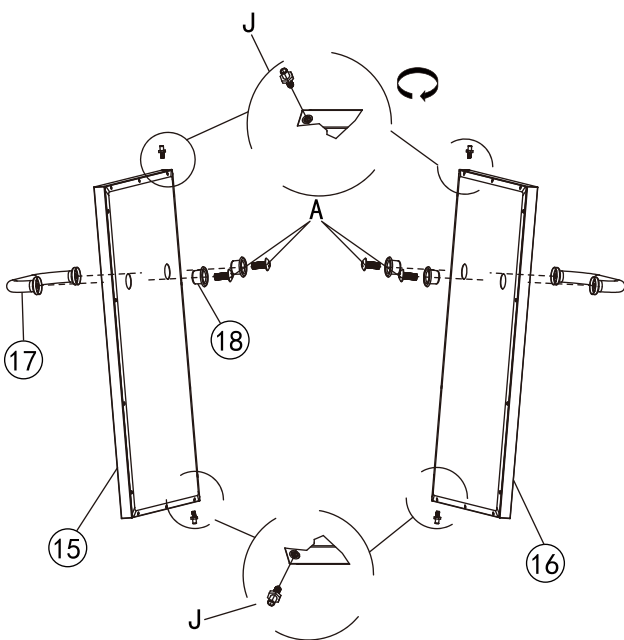

**12** D  ×4

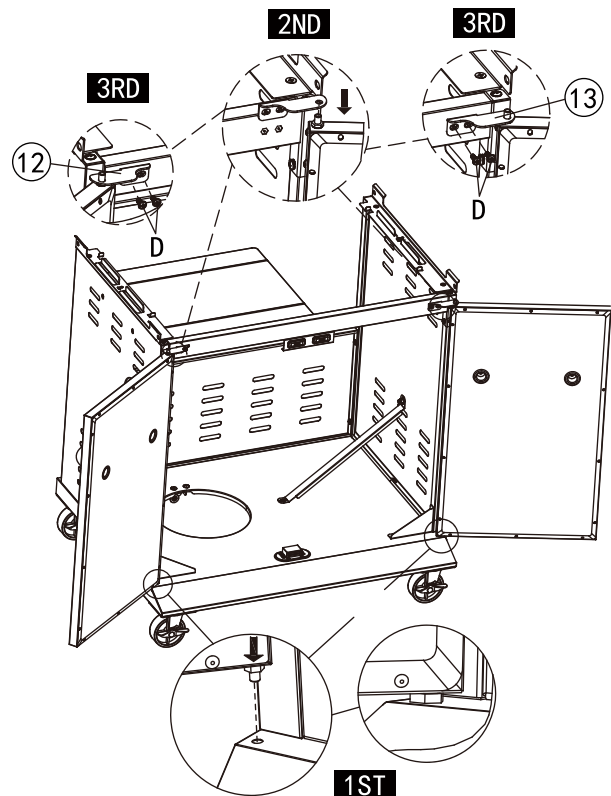



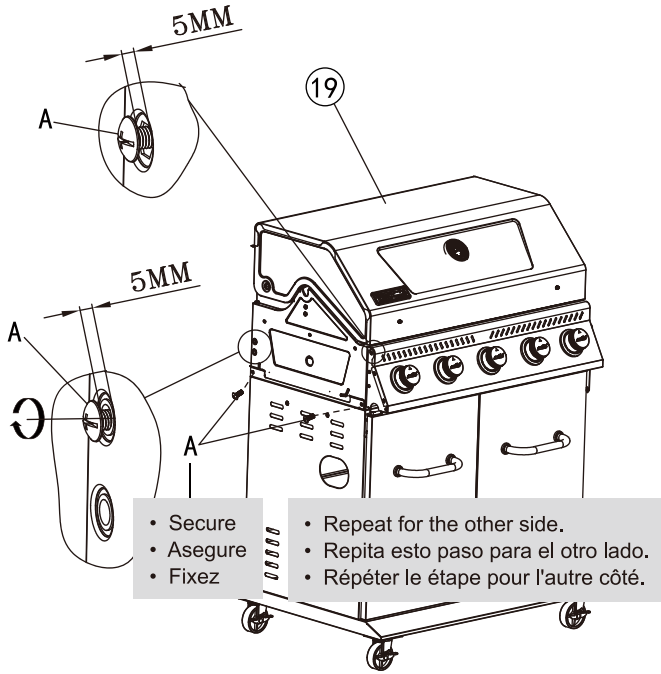

**13** A  x8 

- Release the ignitor, side burner valve and regulator in advance.
- Libere el encendedor, válvula de quemador lateral y regulador por adelantado.
- Déverrouillez l'allumeur, le régulateur du brûleur latéral à l'avance.



- Secure
- Asegure
- Fixez
- Repeat for the other side.
- Repita esto paso para el otro lado.
- Répéter le étape pour l'autre côté.

**14** H  | x2 I  x2  
L  | x2

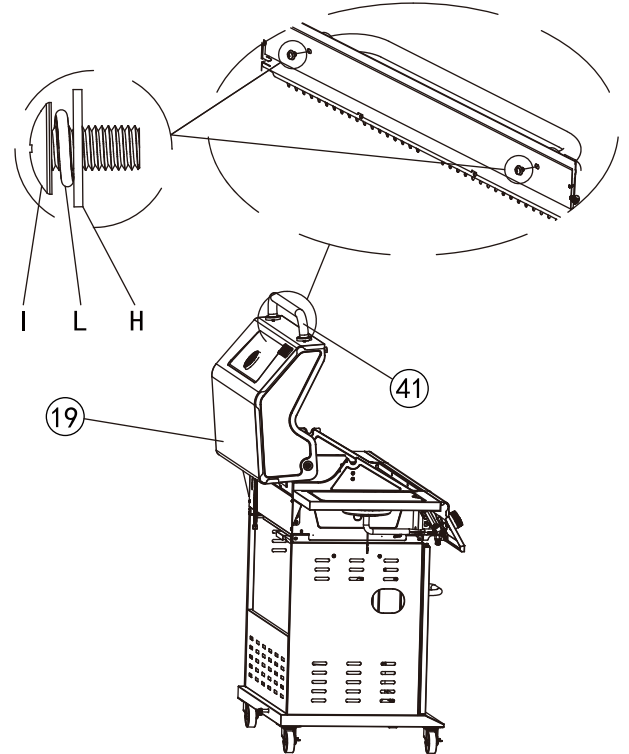



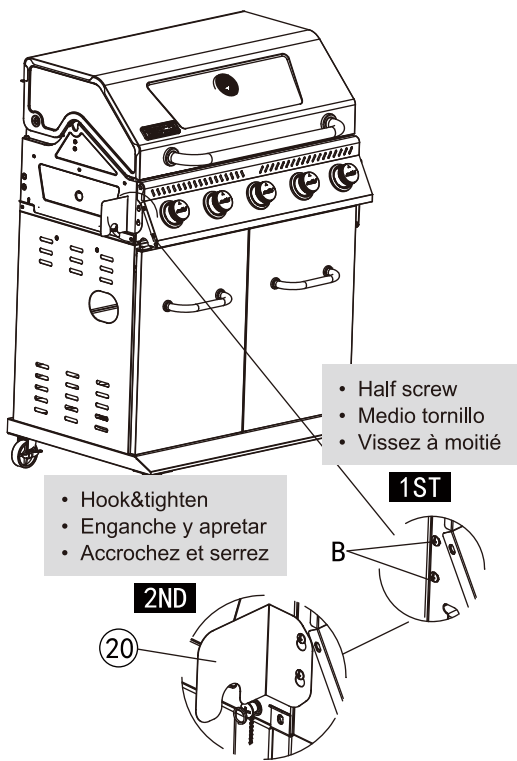

**15** B  x2

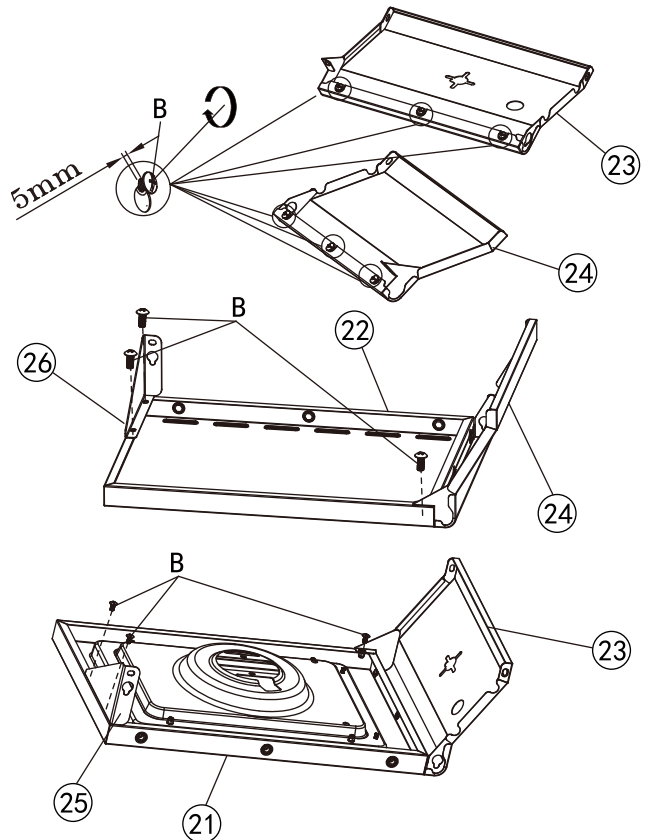

- Half screw
- Medio tornillo
- Vissez à moitié
- Hook&tighten
- Enganche y apretar
- Accrochez et serrez

**16** B  x12



<b>17</b>	A		x8	B		x2
	F		x6			

**1ST**

- Hook side tables to half-screwed bolts, then tighten.
- Engancha las mesas auxiliares a los pernos medio atornillados.
- Accrochez des tables d'appoint à des boulons à moitié dévissés.

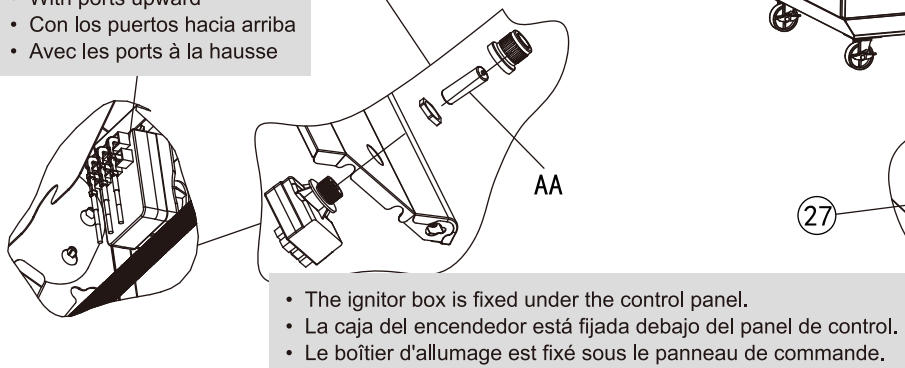
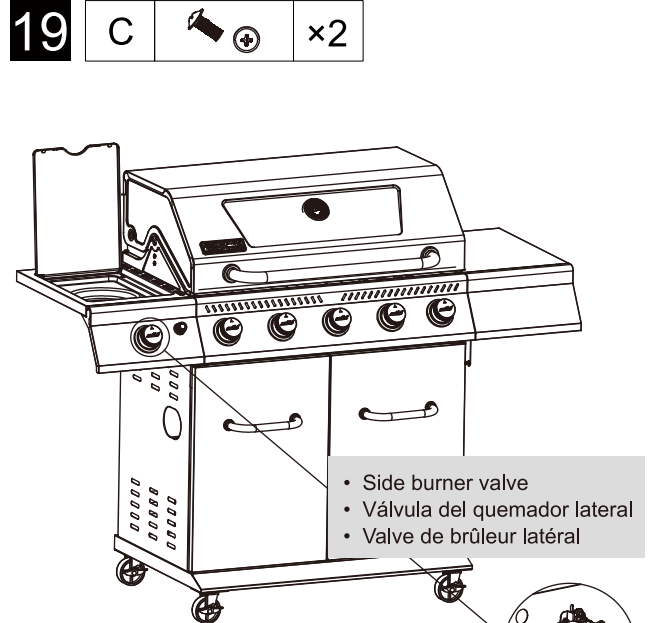
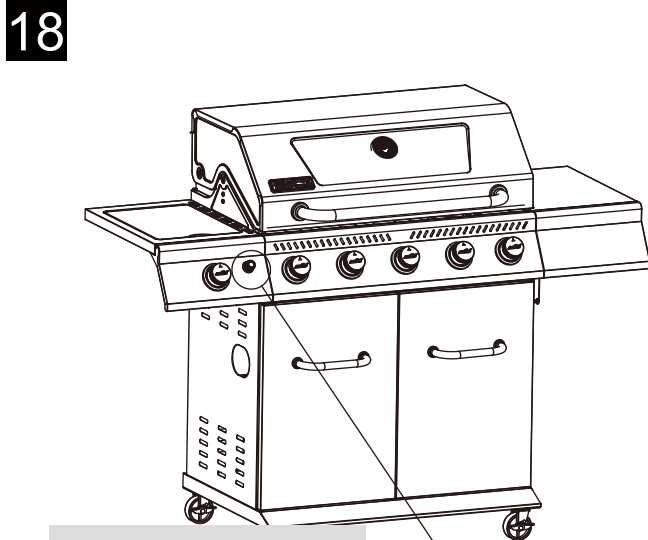
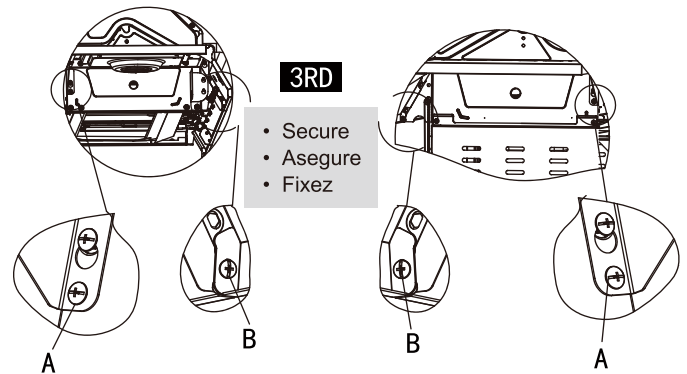
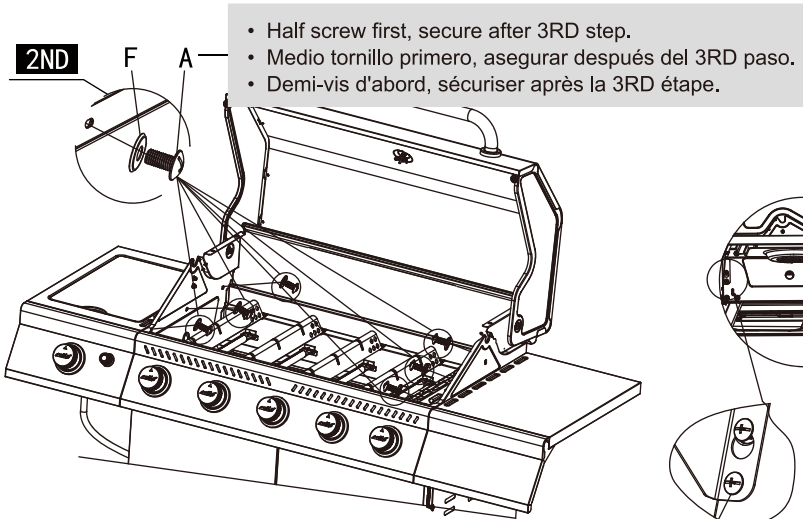

20 C  x2

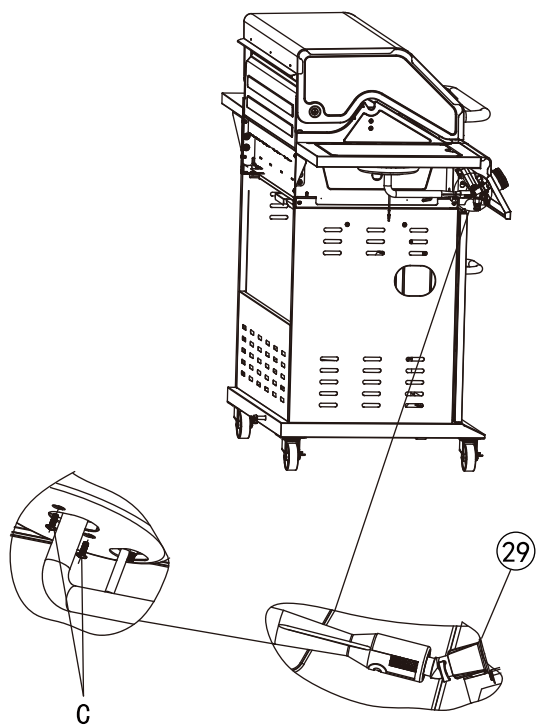

21

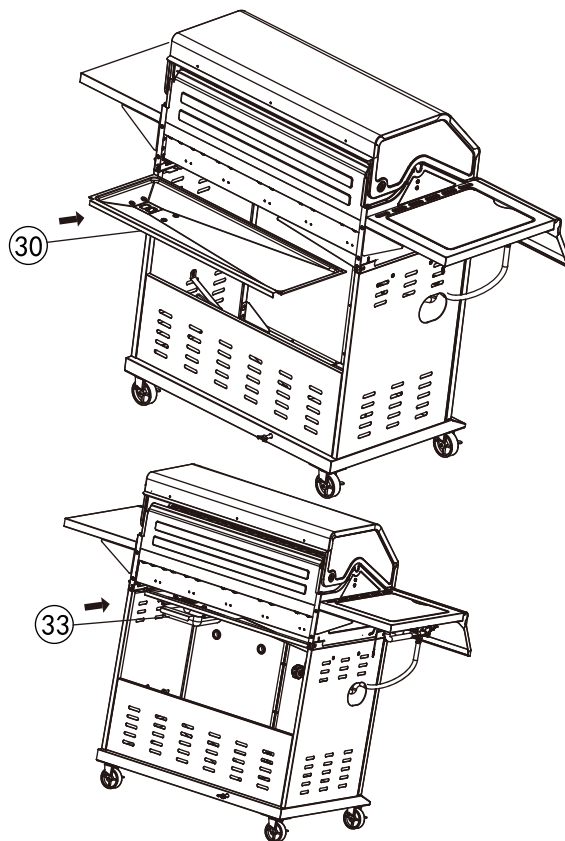

22

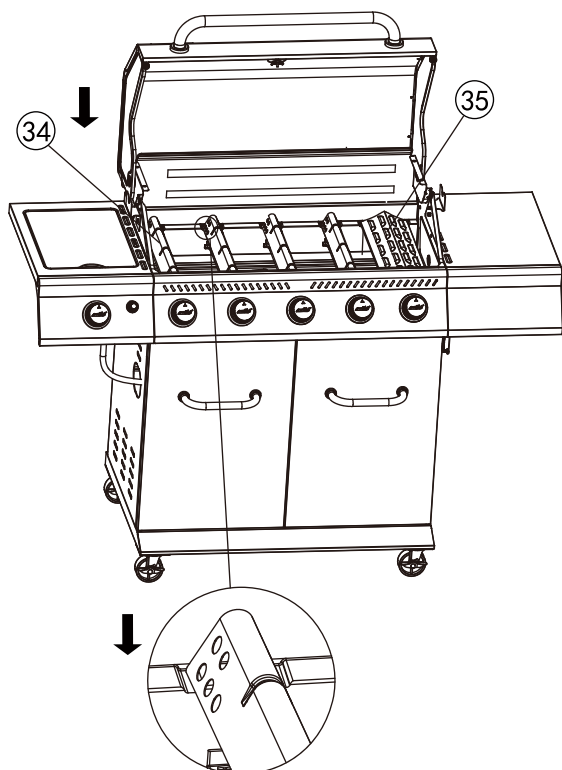

23

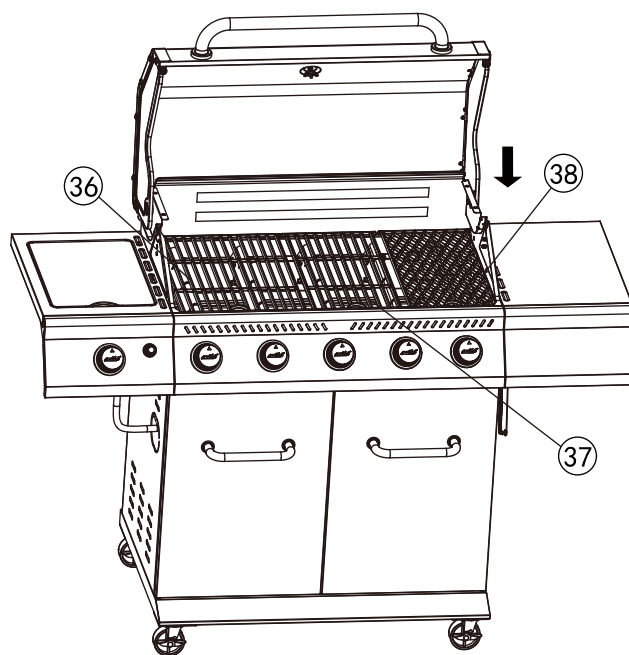

24

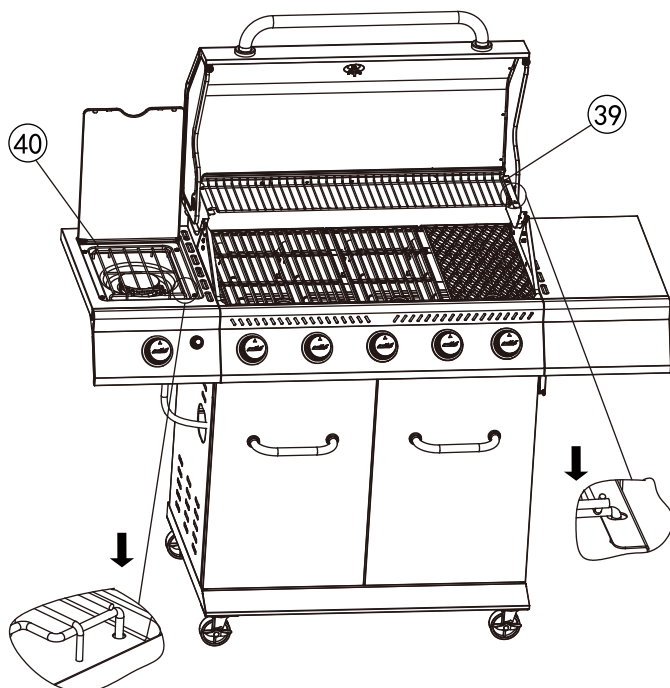

25

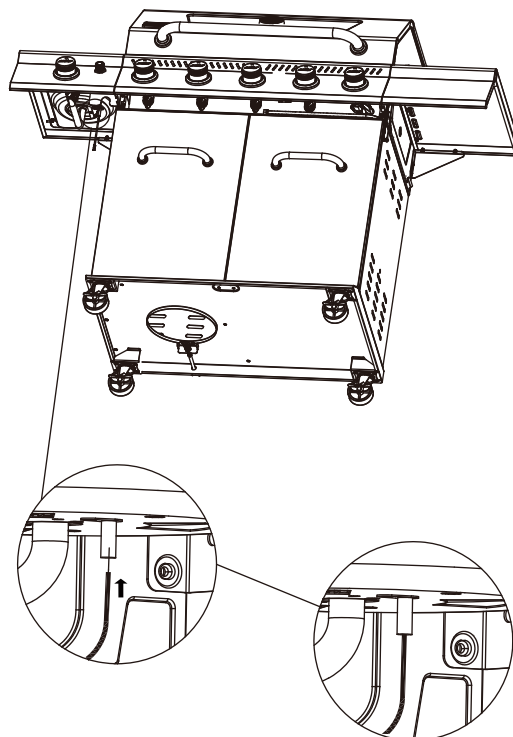

26

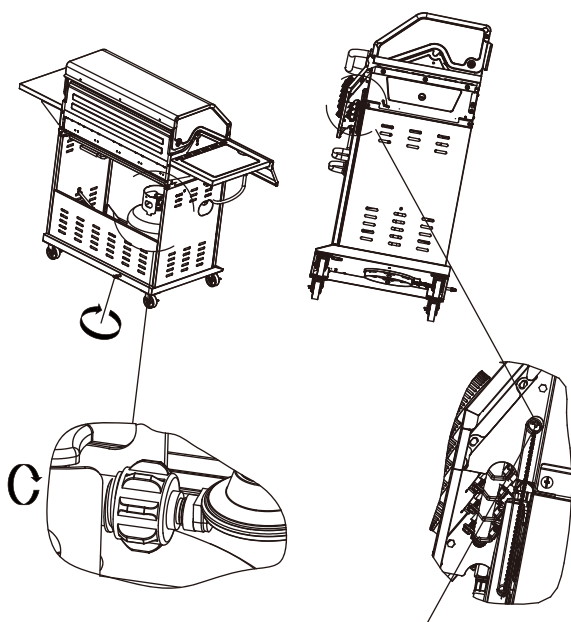

- Please hang the ignition stick here after use.
- Cuelgue las vara de ignición aquí antes de usar.
- Veuillez accrocher le dispositif d'allumage à cet endroit après l'avoir utilisé.

**Thank You  
For Choosing Us.**

**Any Problem!  
We Can Help!**

**Customer  
Service**

**1-800-618-6798**

**Monday to Friday (8:30 am - 5:00 pm EST)**

**[service@royalgourmetusa.com](mailto:service@royalgourmetusa.com)**