





















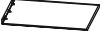











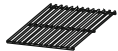



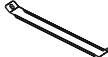

No.	#	QYT / CANT. / QTÉ	Description / Descripción / Description	Image / Imagen / Image
1	05-JSL-40	2	Leg base Base du pied Pata base	
2	HJFTGRF04	1	Right front leg Pata delantera derecha Jambe avant droite	
3	HJFTGRB04	1	Right back leg Pata trasera derecha Jambe arrière droite	
4	HJDB013B-RGC	1	Bottom shelf Estante inferior Etagere inferieure	
5	HJFTGLF01	1	Left front leg Pata delantera izquierda Jambe avant gauche	
6	HJFTGLB01	1	Left back leg Pata trasera izquierda Jambe arrière gauche	
7	AJQPGDZ01	1	Screw bushing Buje del perno de fijación de la bombona Douille de vis	
8	07-QPG-05-SI	1	LP cylinder screw Perno de fijación de la bombona Vis de bouteille de gaz	
9	06-XZL-1-20-DY	1	Wheel axle Eje de las ruedas Axe de roue	
10	05-SLL-02	2	Wheel Rueda Roue	
11	HJQDB033B	1	Cart board Panel de carro Panneau du chariot	
12	HJLTGDBL01	1	Grease tray bracket (L) Fijación de Bandeja de recojida de grasa (L) Support du Lèchefrite (G)	
13	HJLTGDBR01	1	Grease tray bracket (R) Fijación de Bandeja de recojida de grasa (D) Support du Lèchefrite (D)	
14	EJQPGRB01-DS1+ EJQPGRBJQP02	1	Thermal baffle Deflector térmico Panneau isolant	
15	HJGL01	1	Front basket Cesta frontal Panier avant	

No.	#	QYT / CANT. / QTÉ	Description / Descripción / Description	Image / Imagen / Image
16		1	Main body Cuerpo principal Corps principal	
17	HT36HL	1	Side table (L) Mesa lateral (I) Table d'appoint (G)	
18	HT36HR	1	Side table (R) Mesa lateral (D) Table d'appoint (D)	
19	06-XNL-5-17-BK	3	Knob Perilla Bouton	
20	04-GBS-2-05 -248-DH	1	Lid handle Manija de la tapa Poignée du couvercle	
21	ELJYP023B-DS2	1	Grease tray Bandeja de recogida de grasa Lèchefrite	
22	ELYBZJL02	1	Grease cup bracket (L) Fijación de Depósito de recogida de grasa (I) Support du Bac à graisse (G)	
23	ELYBZJR02	1	Grease cup bracket (R) Fijación de Depósito de recogida de grasa (D) Support du Bac à graisse (D)	
24	ELYB02-LS4	1	Grease cup Depósito de recogida de grasa Bac à graisse	
25	HLFHB02	3	Flame tamer Regulador de llama Atténuateur de flamme	
26	03-XKW-E-01 -TC3	1	Cooking grate Rejilla para asar Grille de cuisson	
27	03-XKW-E-02 -TC3	1	Cooking grate (big) Rejilla para asar (grande) Gros grille de cuisson	
28	HLBWW013B -SS4	1	Warming rack Rejilla para calentar Grille de réchauffement	
29	06-WDJ-3-04	1	Thermometer Termómetro Thermomètre	
30	TY-KPQ01-SS4	1	Bottle opener Abridor de botella Ouvre-bouteille	
31	Z-ZH300303	1	LP cylinder barrier bar Barra de seguridad para la bombona de gas Barre de barrière de bouteille de gaz	

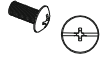
No.	#	Image / Imagen / Image	No.	#	Image / Imagen / Image
A	M5×55	 x16	F	Washer Arandela Rondelle	 x2
B	M5×12	 x27	G	M6×15	 x4
C	Split pin Pasador partido Goupille fendue	 x1	H	M5×10	 x8
D	Washer Arandela Rondelle	 x1	I	Hook Gancho Crochet	 x4
E	Pad Arandela Tampon	 x2	J	M4×8	 x2

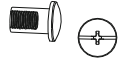
TOOLS REQUIRED / HERRAMIENTAS REQUERIDAS / OUTILS REQUIS		
Description / Descripción / Description		Image / Imagen / Image
Phillips screwdriver Destornillador phillips Tournevis phillips	Wrench Llave Clé	

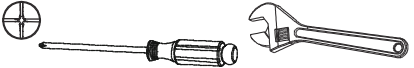
Before beginning assembly, make sure all parts are present. If any parts are missing or damaged, do not attempt to assemble the products. Contact customer service for replacement parts via telephone or email.

- Tools needed (not included): Phillips screwdriver and wrench
- Approximate assembly time: 60 minutes
- Note: 1. The right and left sides of the grill are designed as if you are facing the front of the grill.
2. Model shown for illustration purpose only, specific please in kind prevail.

Antes de comenzar el montaje, asegúrese de que todas las piezas estén presentes. Si falta alguna pieza o está dañada, no intente ensamblar los productos. Póngase en contacto con el servicio de atención al cliente para obtener piezas de repuesto por teléfono o correo electrónico.

- Herramienta necesaria (no incluido): Destornillador phillips y llave
- Tiempo aproximado de ensamblaje: 60 minutos
- Nota: 1. Los lados derecho e izquierdo de la parrilla están diseñados como si estuvieras frente a la parte delantera de la parrilla.
2. El modelo que se muestra es sólo para fines ilustrativos, prevalecen los específicos en especie.

Avant de commencer l'assemblage, assurez-vous que toutes les pièces sont présentes. Si des pièces sont manquantes ou endommagées, n'essayez pas d'assembler les produits. Contactez le service de clientèle pour les pièces de rechange par téléphone ou par e-mail.

- Outils nécessaires (non inclus): Tournevis phillips et clé
- Temps nécessaire pour l'assemblage: 60 minutes
- Remarque: 1. Les côtés droit et gauche du gril sont conçus comme si vous faisiez face à l'avant du gril.
2. Le modèle est présenté à des fins d'illustration uniquement, spécifiques en nature prévalent.

1

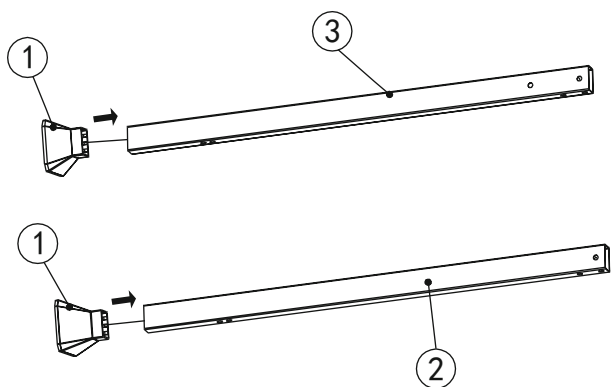

2 G  ⊕ ×2

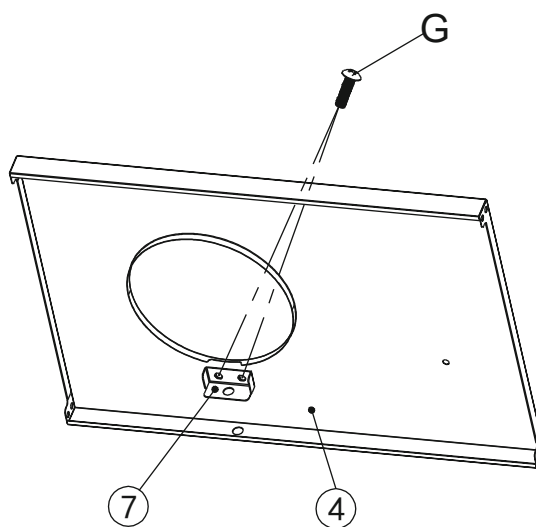

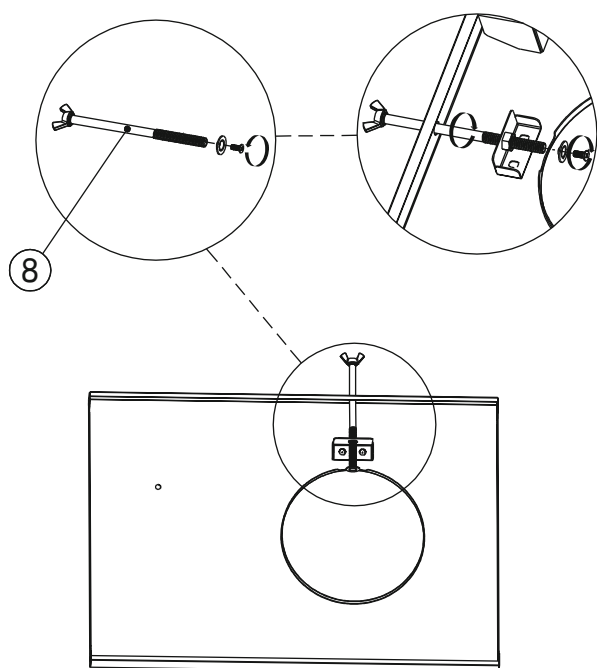

3

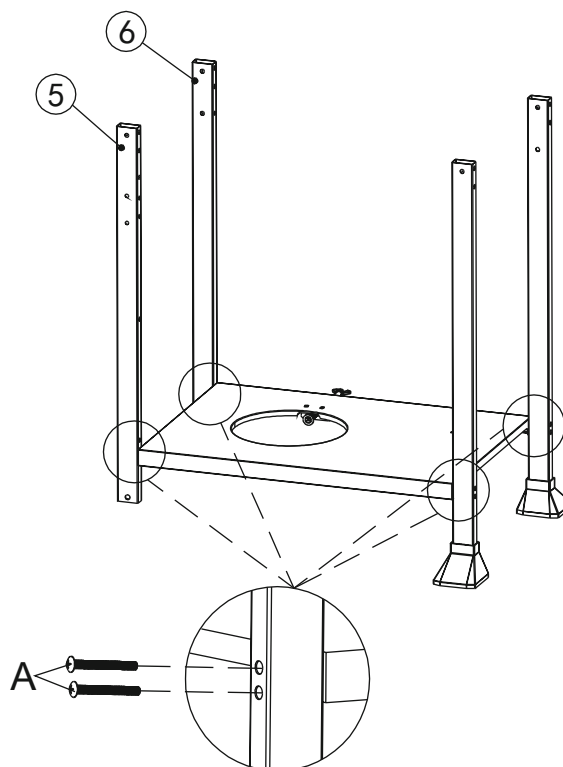

4 A  ⊕ ×8



5 E  x2 C  x1

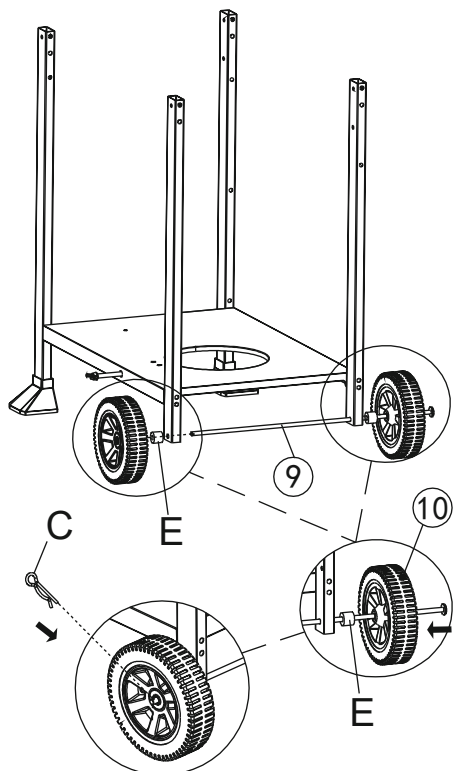

6 B  x6

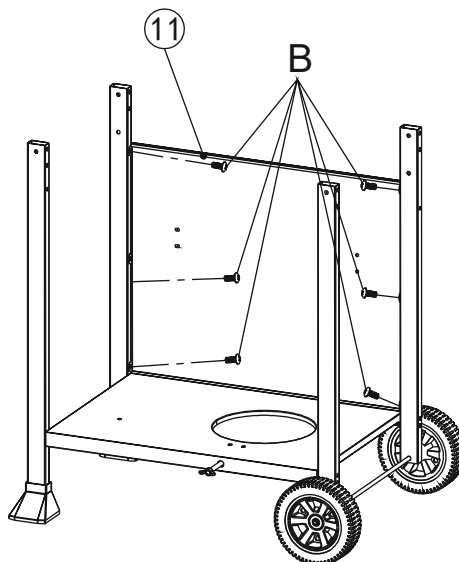

7 B  x6

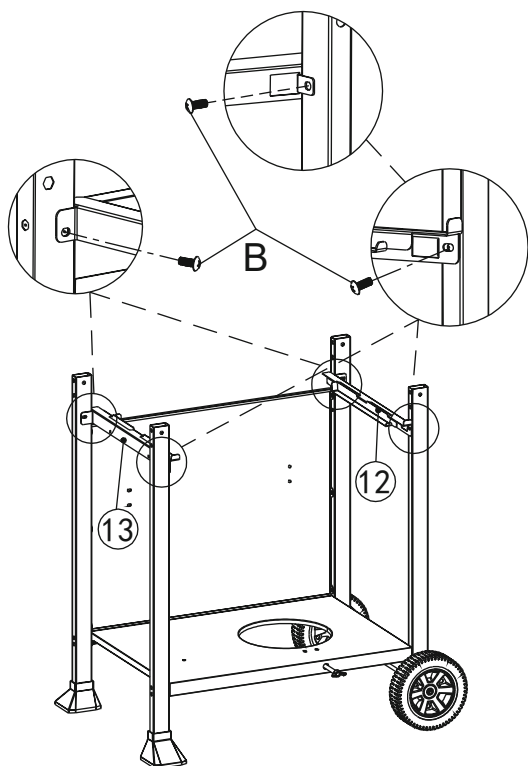

8 B  x2

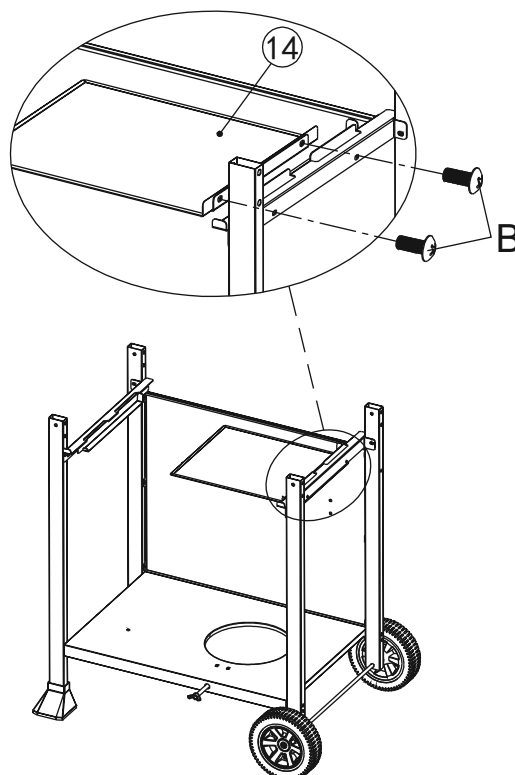

9

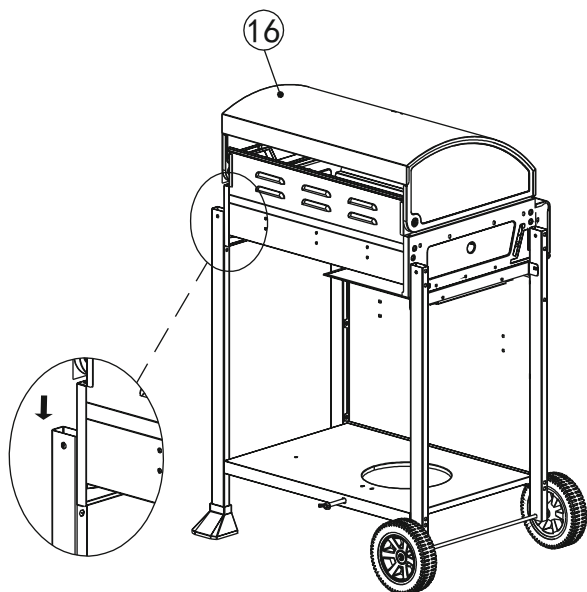

10

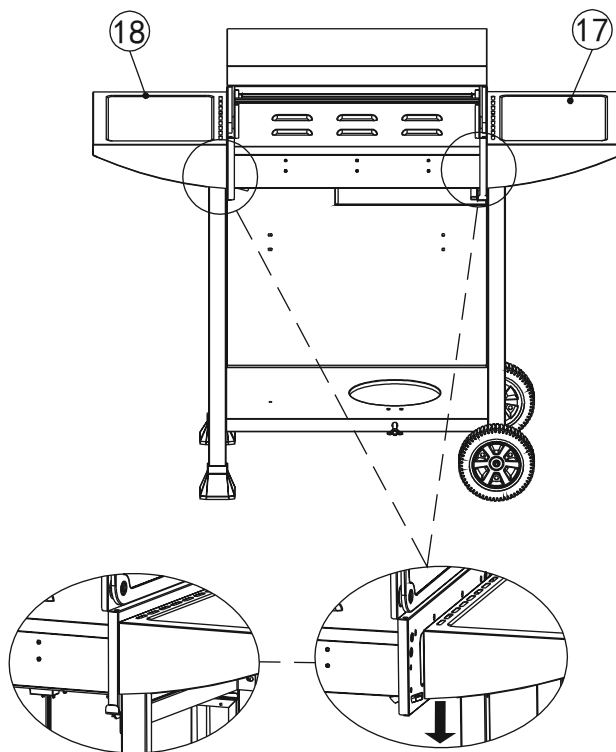

11 B  x8

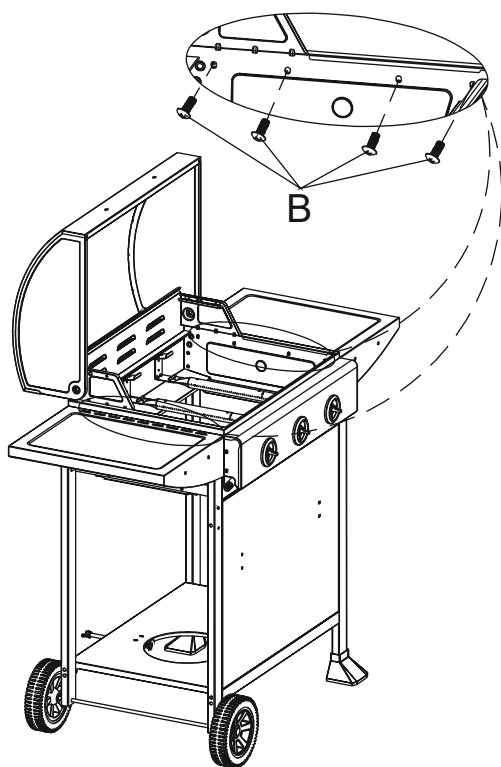

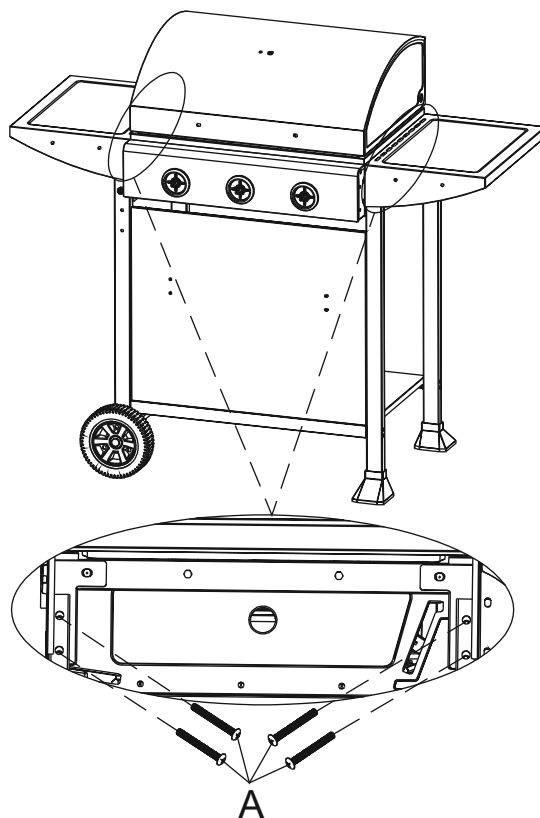

12 A  x8

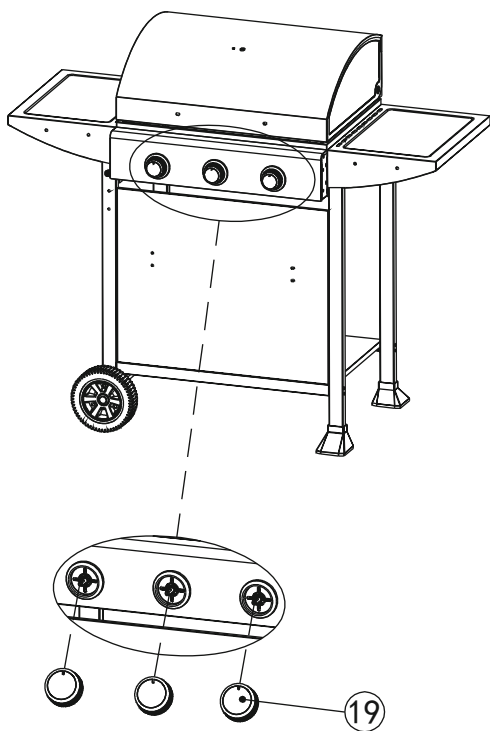

13



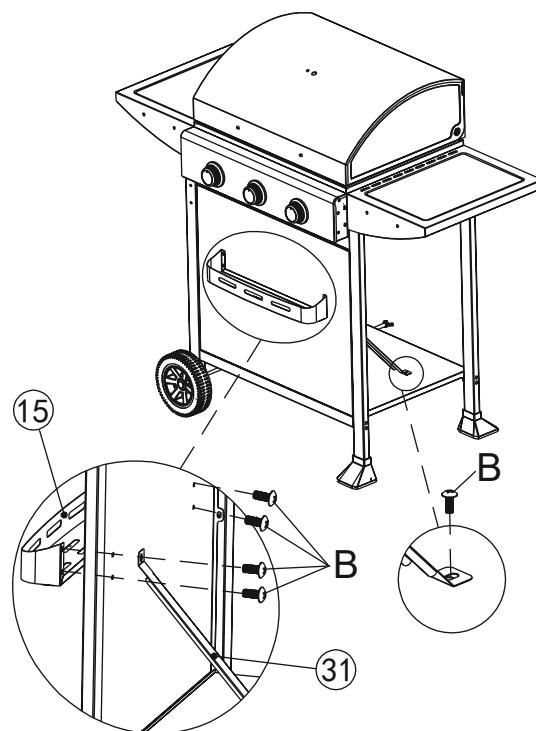

14

B   x5



15

H   x4

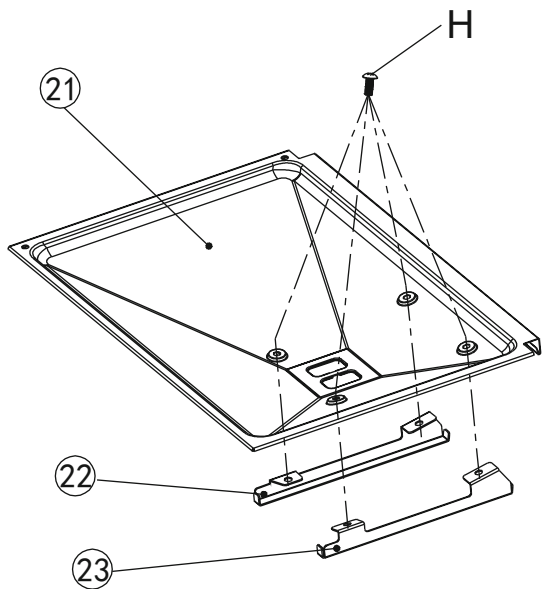

16

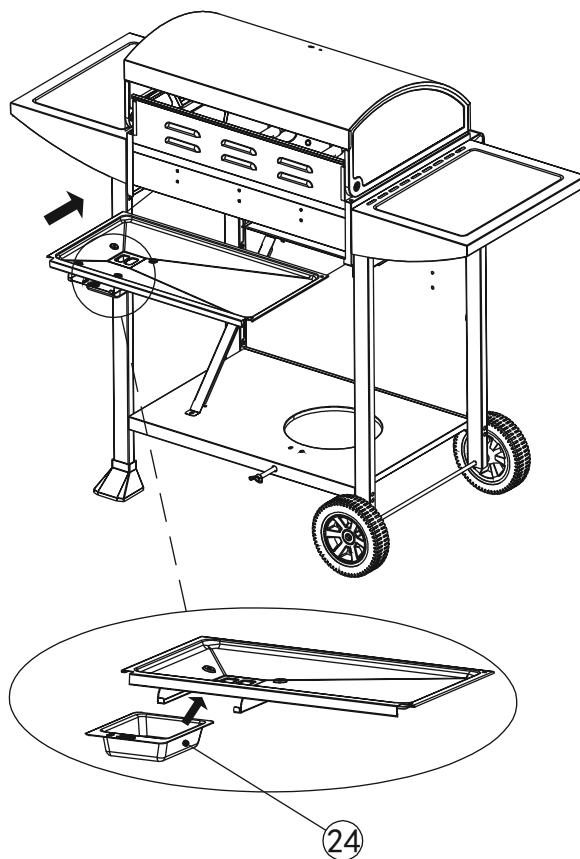

17

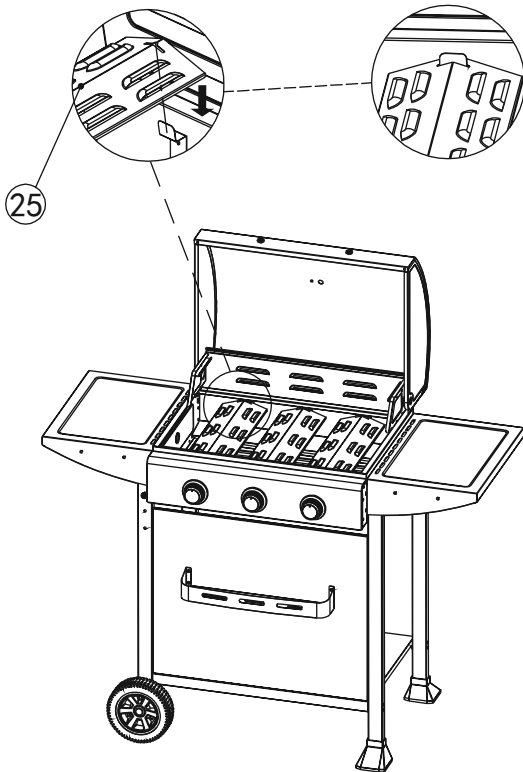

18

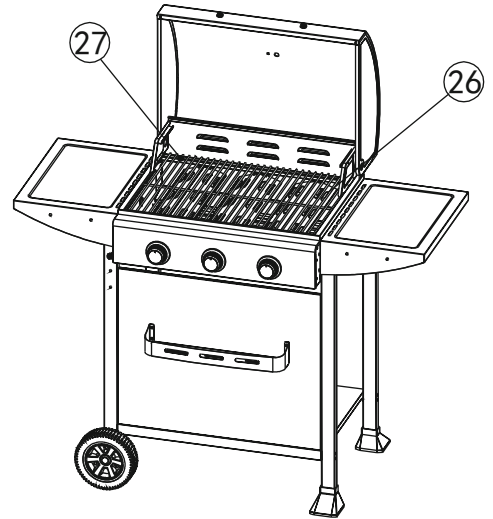

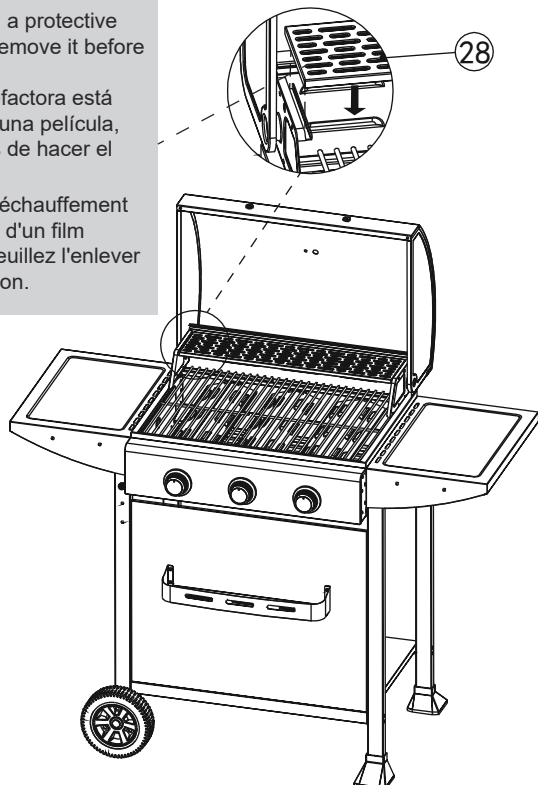

19

- Covered with a protective film, please remove it before use.
- La rejilla calefactora está cubierta con una película, retírela antes de hacer el primer uso.
- Le Grille de réchauffement est recouvert d'un film protecteur, veuillez l'enlever avant utilisation.

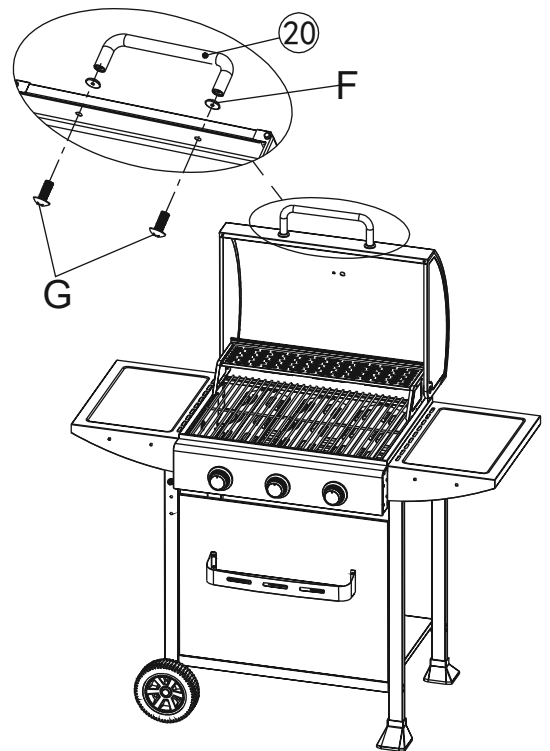

20



21	H		x4	I		x4
	D		x1			

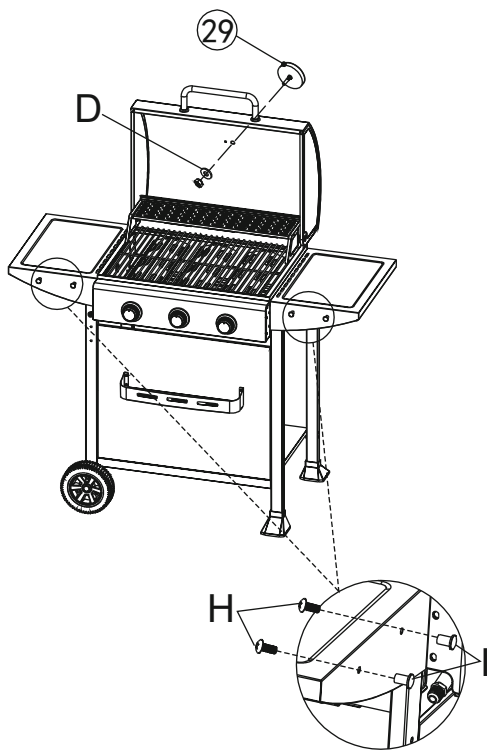

22	J		x2
----	---	--	----

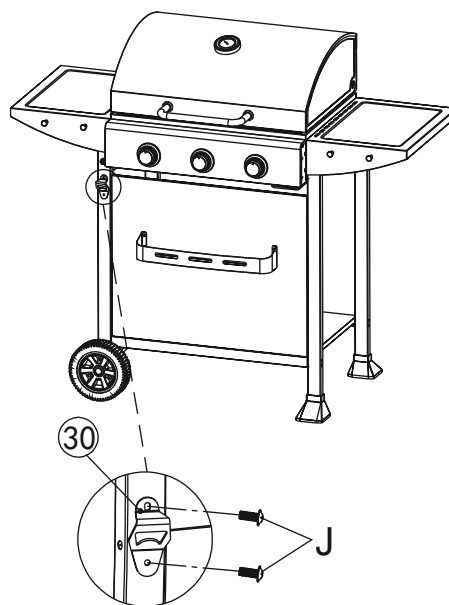

23

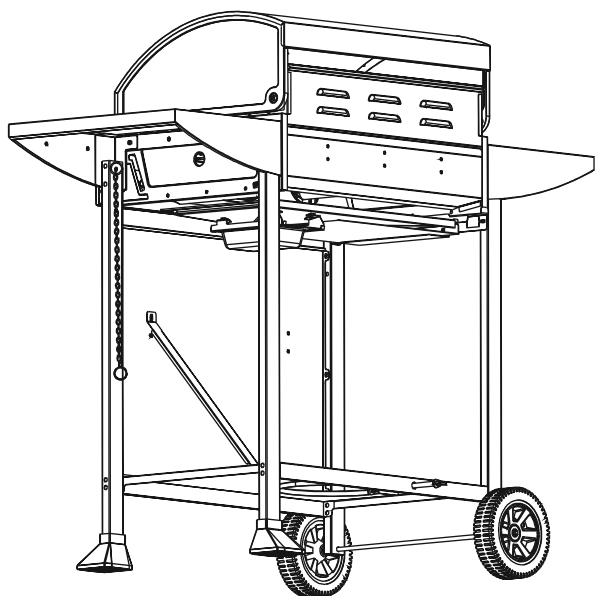

**Thank You
For Choosing Us.**

**Any Problem!
We Can Help!**

**Customer
Service**

1-800-618-6798

Monday to Friday (8:30 am - 5:00 pm EST)

service@royalgourmetusa.com