

SAVANNAH SWING PLAYHOUSE
ENSEMBLE DE BALANÇOIRES SAVANNAH
JUEGO DE COLUMPIOS SAVANNAH

BILT®

Easy step-by-step 3D interactive instructions for this product can be found in BILT®. Download today.

Des instructions interactives 3D simples, étape par étape, pour ce produit sont disponibles dans BILT®. Télécharger maintenant.

Encontrará instrucciones detalladas, sencillas e interactivas en versión 3D para este producto en BILT®. Descárguelas ya.



CALL US OR GO ONLINE
APPELEZ-NOUS OU ALLEZ EN LIGNE
LLÁMENOS O VISITE NUESTRO SITIO WEB

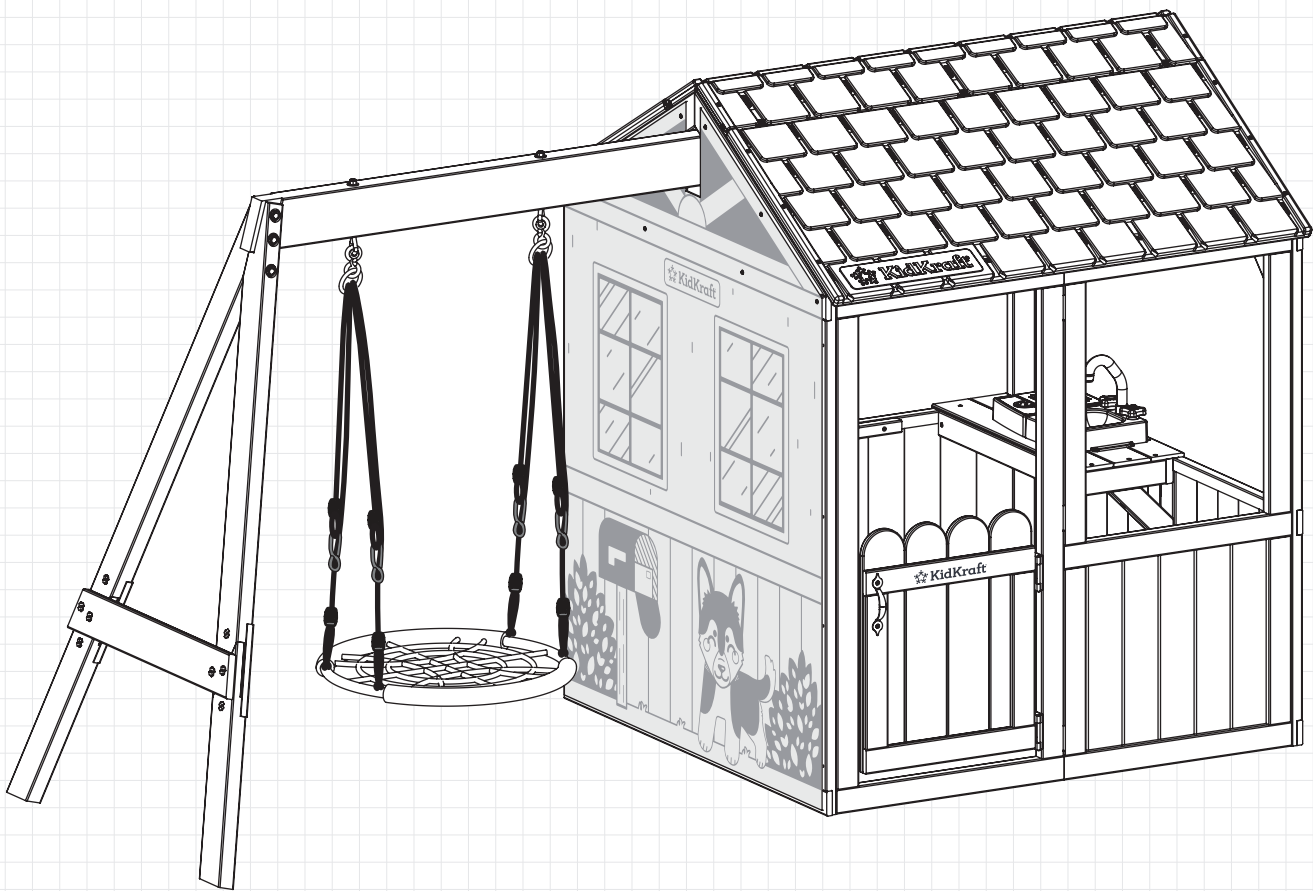

ASSEMBLY INSTRUCTIONS / INSTRUCTIONS D'ASSEMBLAGE / INSTRUCCIONES DE MONTAJE

**FOR 24/7 ONLINE PARTS REPLACEMENT / POUR LE
REPLACEMENT 24/7 DES PIÈCES EN LIGNE / PARA SOLICITUDES
ONLINE DE PIEZAS DE REPUESTO DE MANERA ININTERRUMPIDA**

parts.kidkraft.com

KidKraft, Inc.
4630 Olin Road
Dallas, Texas 75244
USA

customerservice@kidkraft.com

1.800.933.0771
972.385.0100

parts.kidkraft.eu

KidKraft Netherlands BV
Olympisch Stadion 8
1076 DE Amsterdam
The Netherlands

europecustomerservice@kidkraft.com

+31 20 305 8620
M-F from 09:00 to 17:30 (GMT+1)

BATCH CODE / CODE DE LOT / CÓDIGO DE LOTE

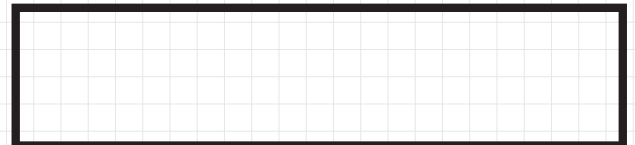

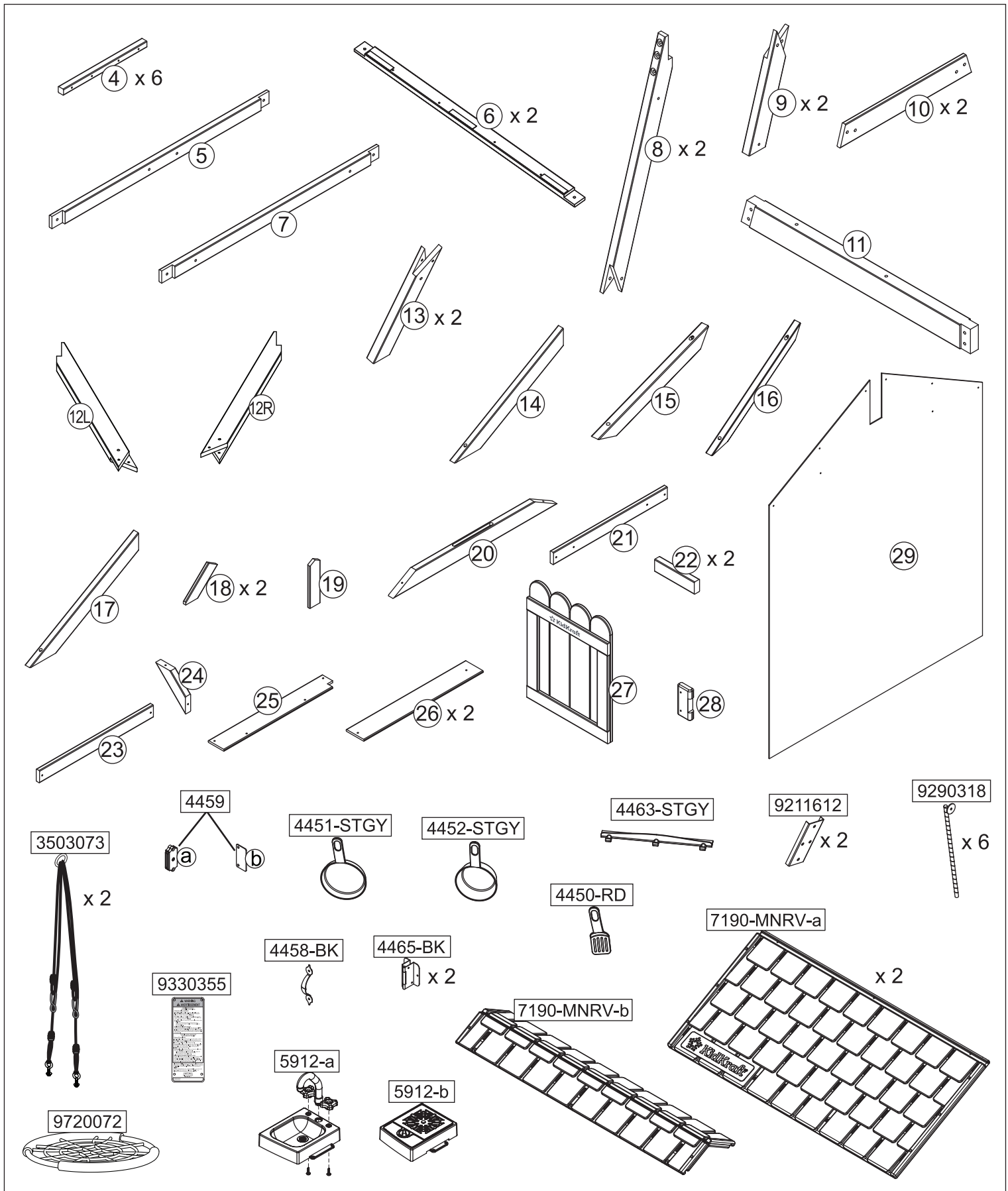

Parts and Hardware
Pièces et matériel
Partes y Piezas Para Instalación
Teile und Befestigungsmaterial
Parti e componenti meccanici

If you need to order parts,
please order below part#

Si necesita pedir piezas,
utilice el número de pieza
indicado a continuación
para realizar el pedido

Si vous avez besoin de
commander des pièces,
veuillez utiliser le numéro
de référence ci-dessous.

P-P280169E-1A
P-P280169E-1B
P-P280169E-2A
P-P280169E-2B
P-P280169E-ZZ1
9323687

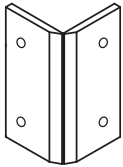

9323687
(6 Pcs)

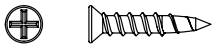

ZZ1
(24 Pcs)

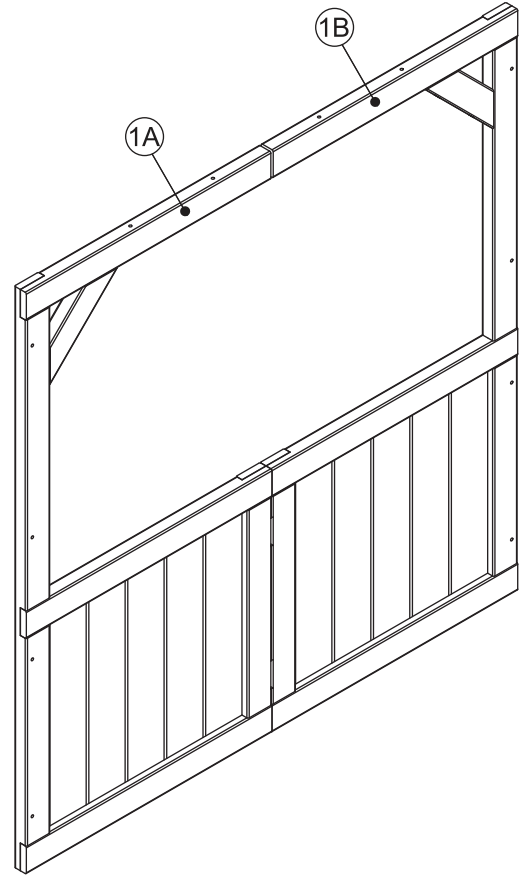
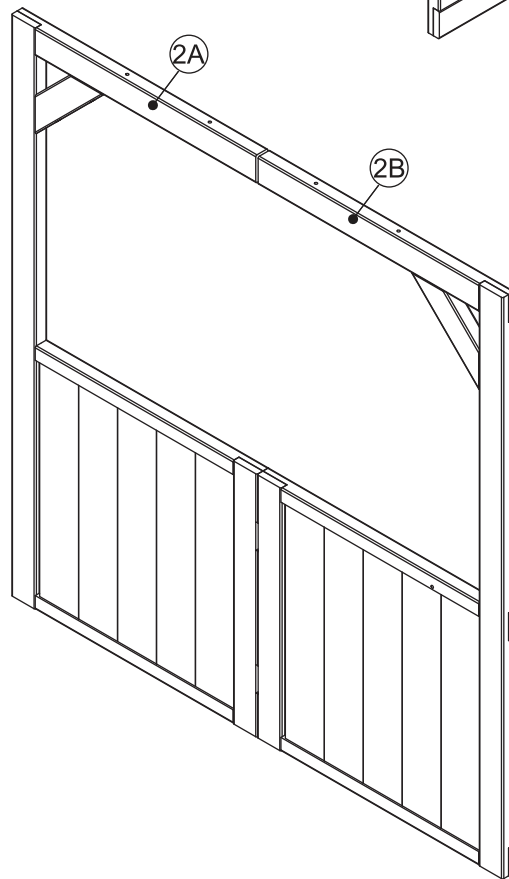

Parts and Hardware
Pièces et matériel
Partes y Piezas Para Instalación
Teile und Befestigungsmaterial
Parti e componenti meccanici

All hardware dimensions are approximate.
Toutes les dimensions du matériel
sont approximatives.
Todas las dimensiones de las herramientas
son aproximaciones.

europcustomerservice@kidkraft.com
+31 20 305 8620
M-F from 09:00 to 17:30 (GMT+1)

parts.kidkraft.eu



If you need to order parts,
please order below part#

Si necesita pedir piezas,
utilice el número de pieza
indicado a continuación
para realizar el pedido

Si vous avez besoin de
commander des pièces,
veuillez utiliser le numéro
de référence ci-dessous.

P-P280169E-3A
P-P280169E-3B
P-P280169E-ZZ1
9323687

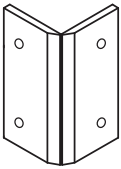
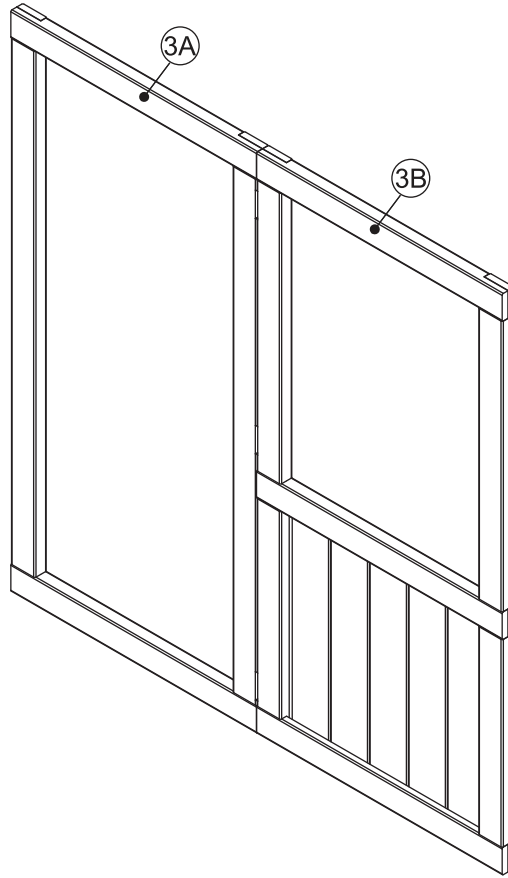

9323687
(3 Pcs)

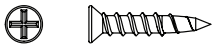

ZZ1
(12 Pcs)











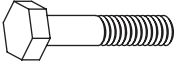



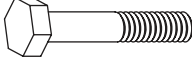

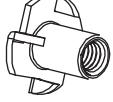

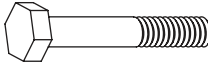

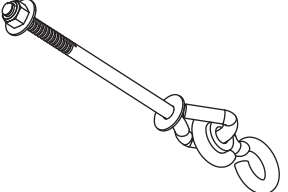

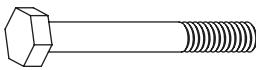

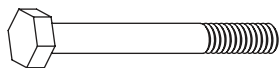

Parts and Hardware
Pièces et matériel
Partes y Piezas Para Instalación
Teile und Befestigungsmaterial
Parti e componenti meccanici

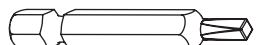
All hardware dimensions are approximate.
Toutes les dimensions du matériel
sont approximatives.
Todas las dimensiones de las herramientas
son aproximaciones.

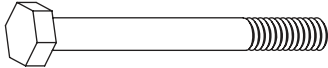

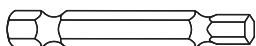
parts.kidkraft.com

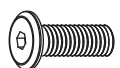
customerservice@kidkraft.com
1.800.933.0771
972.385.0100

S20	x 14	H1	x 4	LN1	x 4	FW2	x 4
							
34 mm		42 mm					
S15	x 63	H2	x 8	LN2	x 2	TN1	x 20
							
44 mm		54 mm					
S3	x 6	H3	x 4	LNJ	x 6	SH1	x 2
							
62 mm		68 mm					
S4	x 8	H4	x 2	LW1	x 20	PBJ	x 6
							
75 mm		105 mm				18 mm	
S37	x 36	H6	x 2	LW2	x 2	D4	x 1
							
16 mm		124 mm					
S38	x 2	G13	x 2	FW0	x 20	D6	x 1
							
29 mm		160 mm					
S6	x 6	WB3	x 4	FW1	x 28		
							
24 mm		28 mm					

Parts and Hardware
Pièces et matériel
Partes y Piezas Para Instalación
Teile und Befestigungsmaterial
Parti e componenti meccanici

All hardware dimensions are approximate.
Toutes les dimensions du matériel
sont approximatives.
Todas las dimensiones de las herramientas
son aproximaciones.

europcustomerservice@kidkraft.com
+31 20 305 8620
M-F from 09:00 to 17:30 (GMT+1)

parts.kidkraft.eu



1

1 x ①

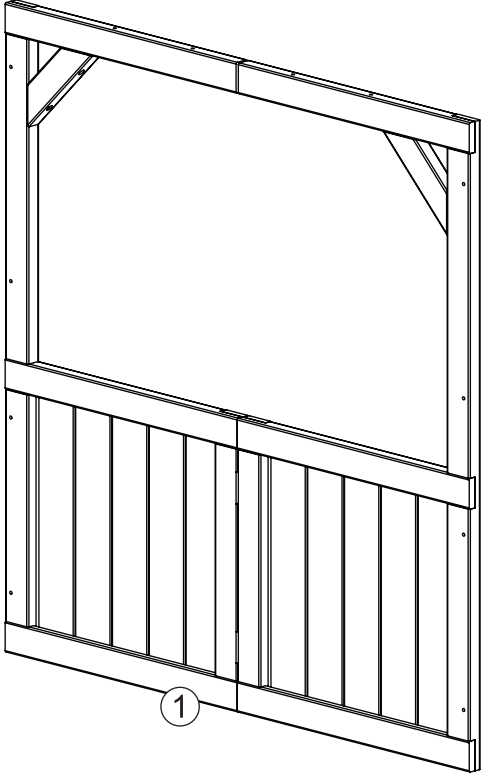
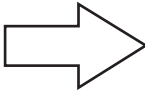
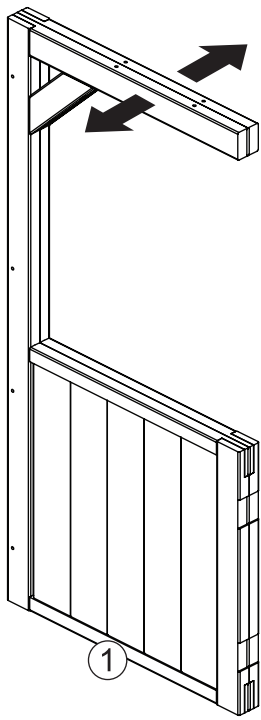

2

1 x ②

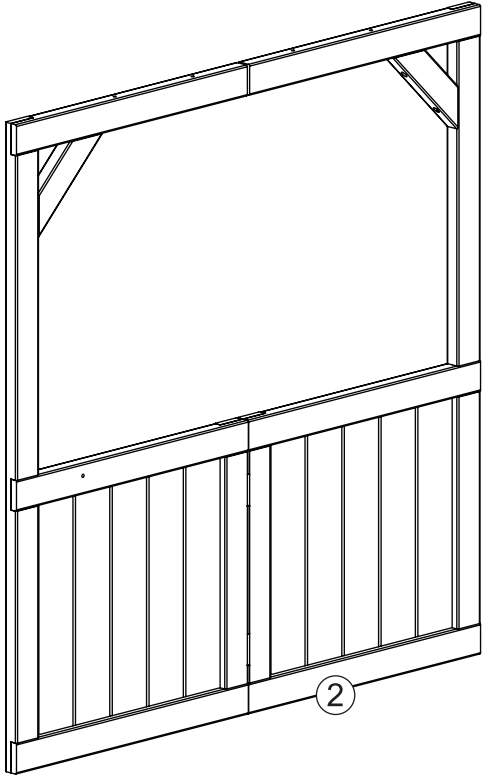
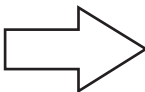
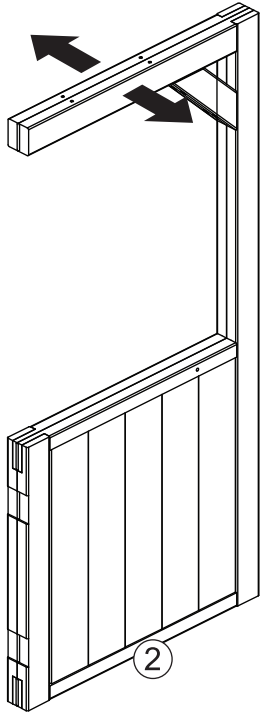

3

Notice hole orientation.
 Make sure assembly is square.
 Faites attention à l'orientation des trous.
 Assurez-vous que l'assemblage soit bien droit.
 Tenga en cuenta la orientación de los orificios.
 Asegúrese de que el conjunto esté en perpendicular.
 Ausrichtung der Bohrungen beachten.
 Die Bauteile müssen sich im rechten Winkel zueinander befinden.
 Prestare attenzione all'orientamento dei fori.
 Accertarsi che l'assemblato sia in squadra.

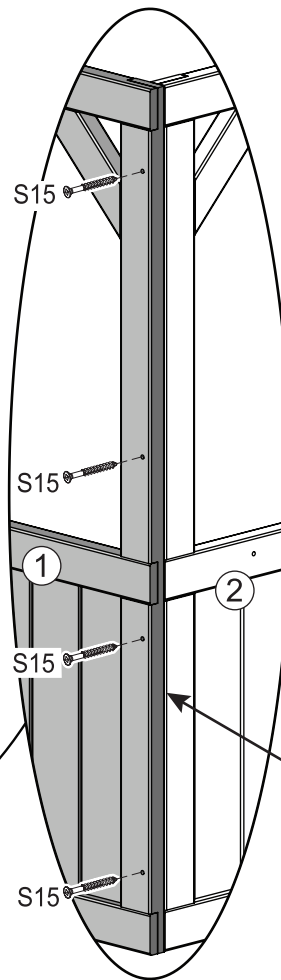
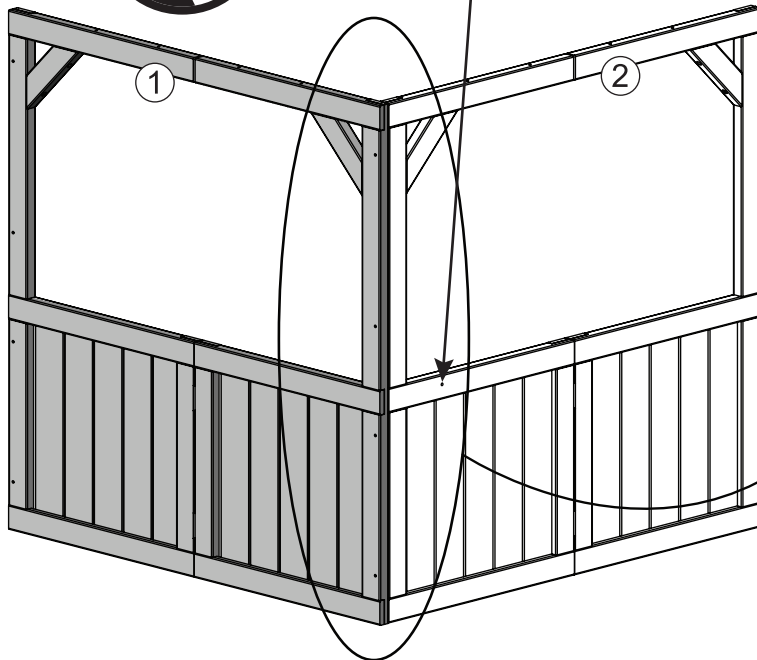

4 x S15



Flush
 Aligné
 A ras
 Bündig
 A filo

4

1 x 3

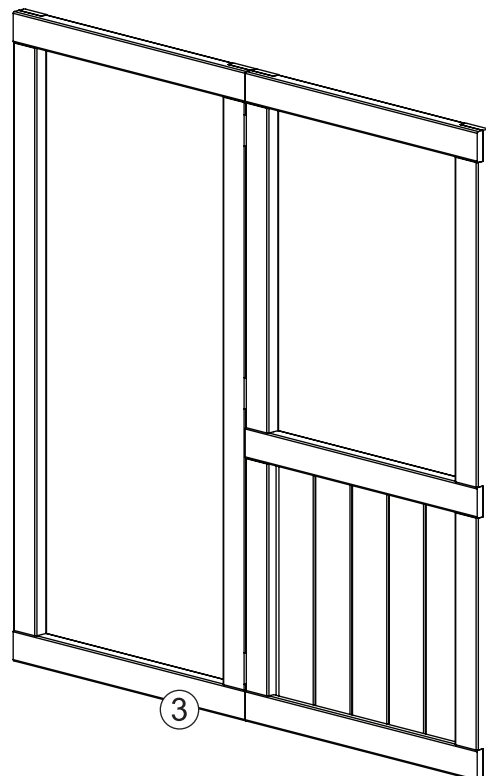
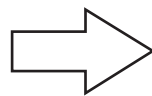
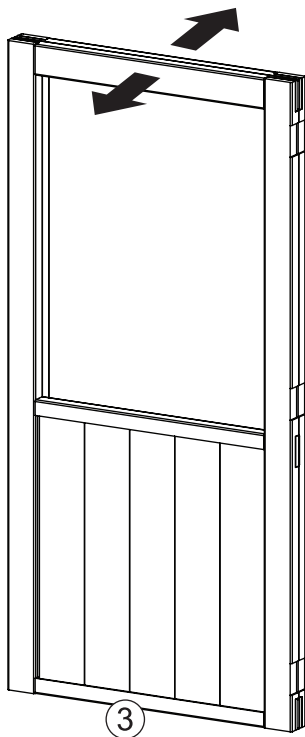

5

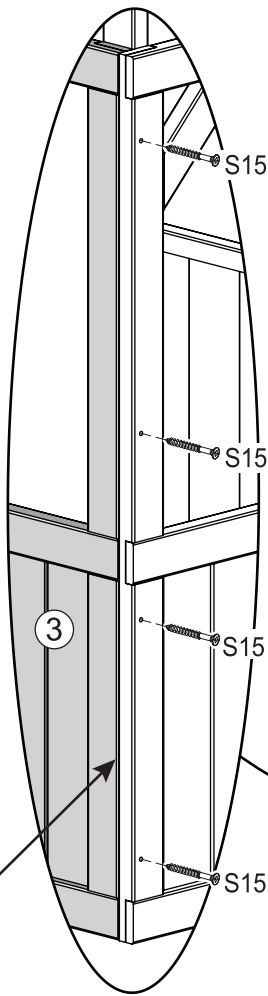

Make sure assembly is square.
 Assurez-vous que l'assemblage soit bien droit.
 Asegúrese de que el conjunto esté en perpendicular.
 Die Bauteile müssen sich im rechten Winkel zueinander befinden.
 Accertarsi che l'assemblato sia in squadra.

4 x S15

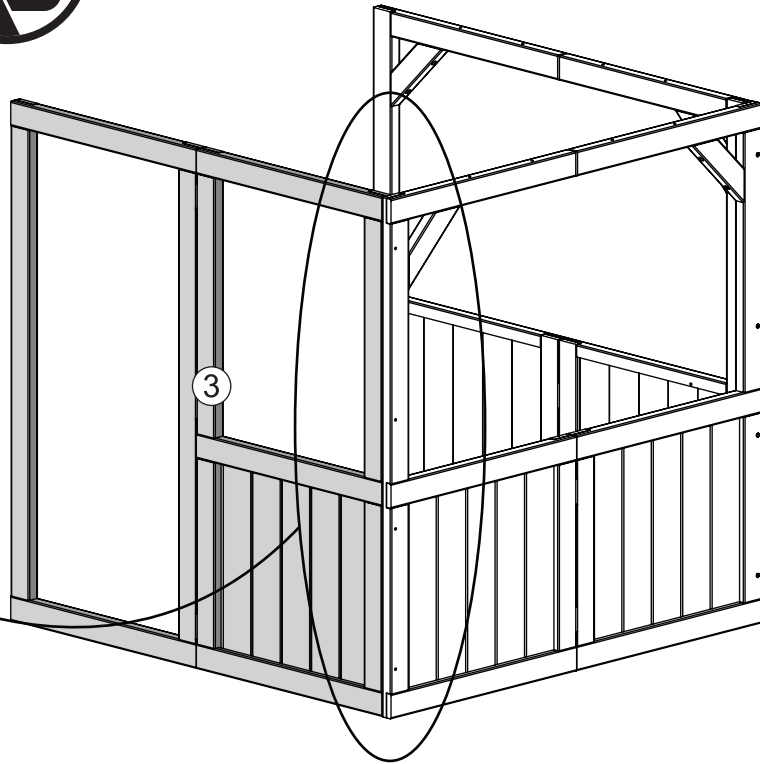

6

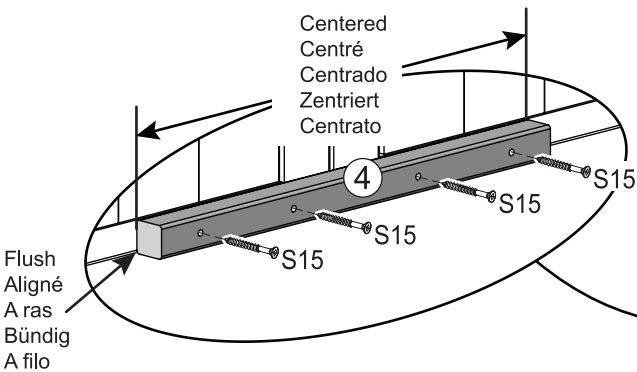
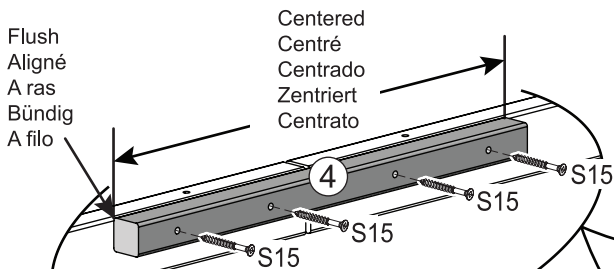

3 x 4

12 x S15

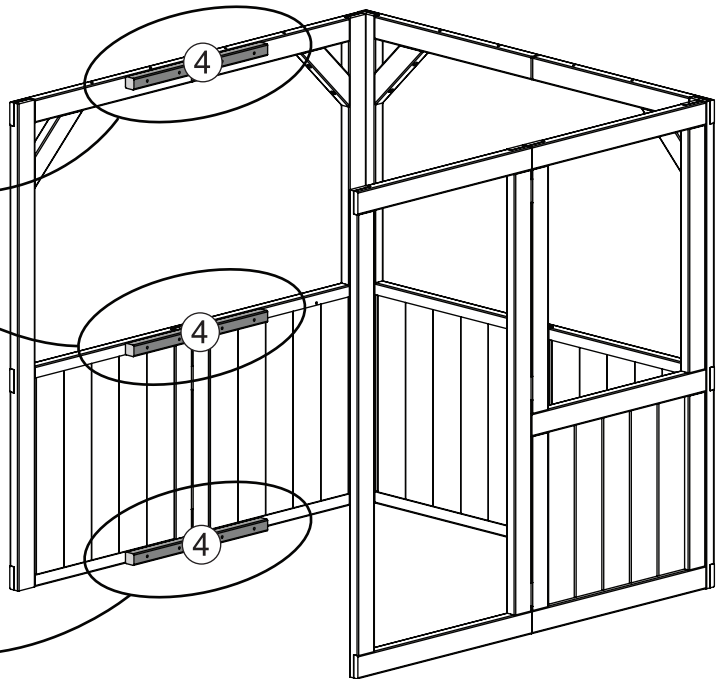

7



1 x 4

4 x S15

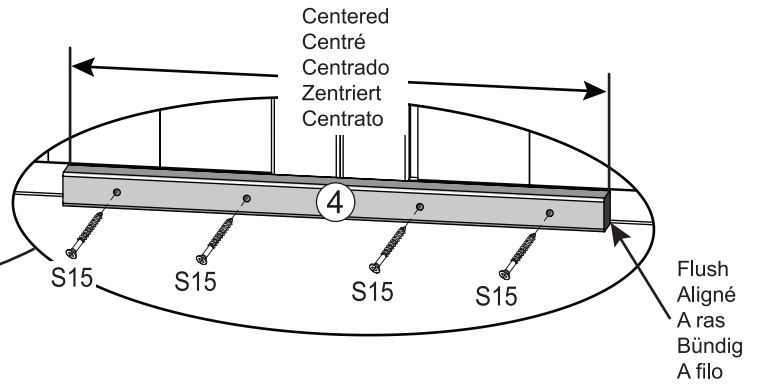
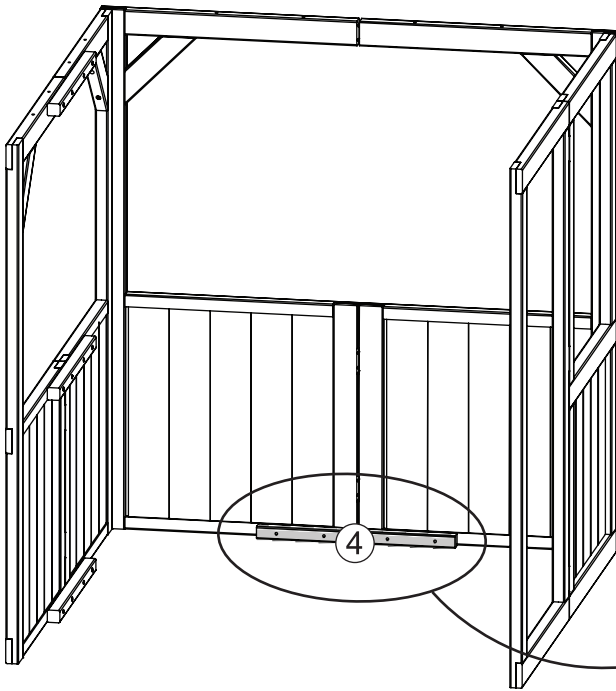

8



2 x 4

8 x S15

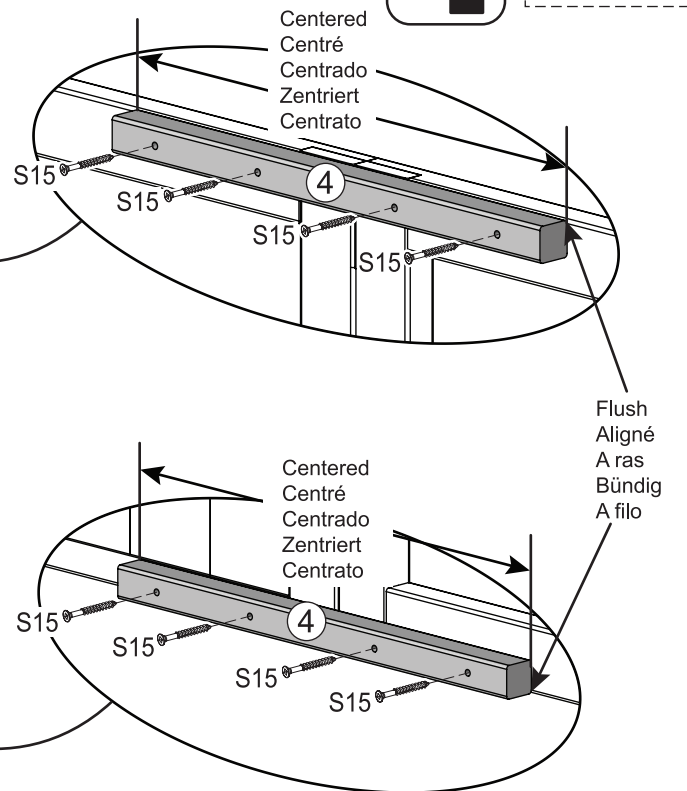
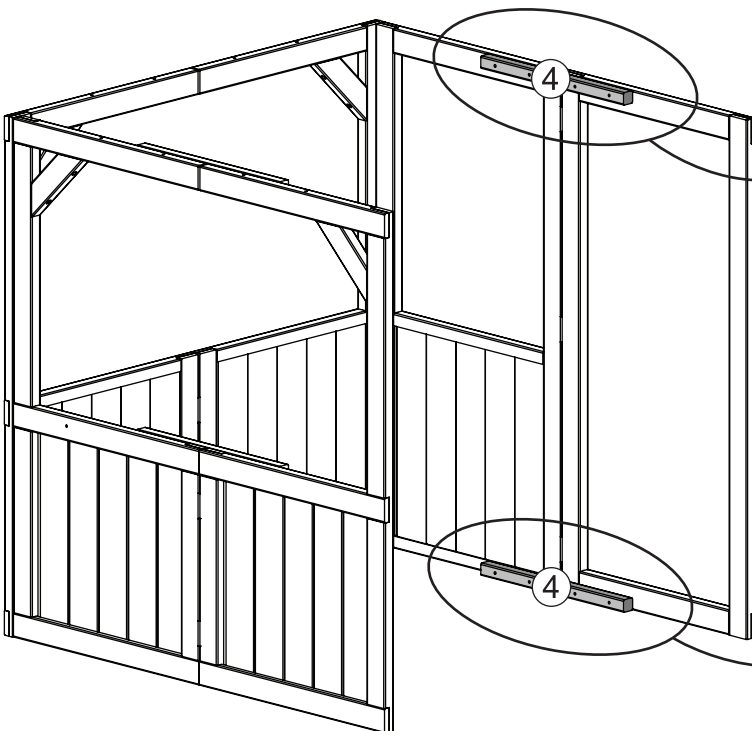

9

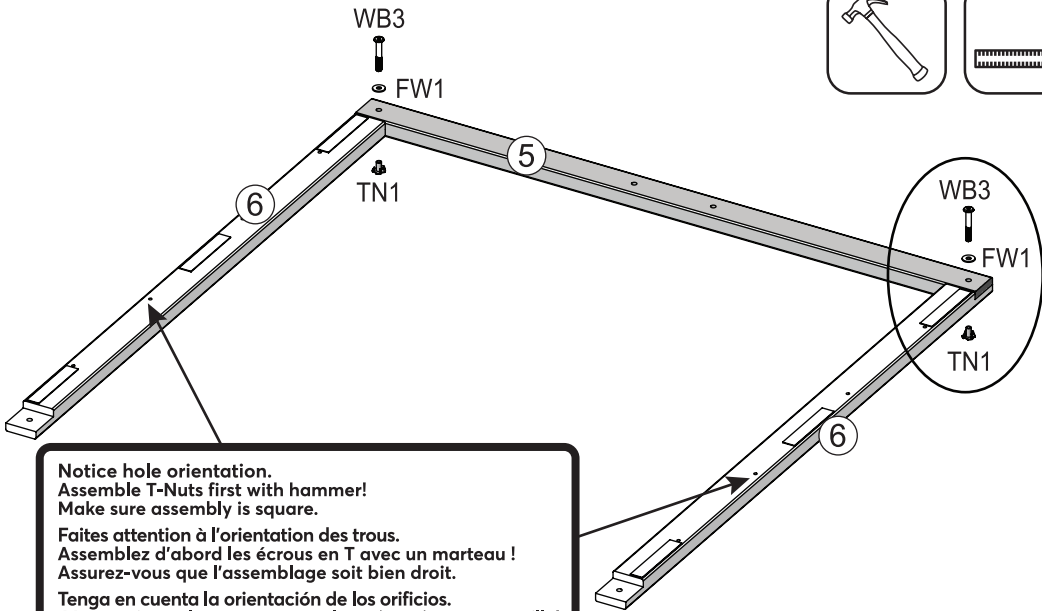

- 1 x 5
- 2 x 6

- 2 x WB3
- 2 x FW1
- 2 x TN1

Notice hole orientation.
 Assemble T-Nuts first with hammer!
 Make sure assembly is square.

Faites attention à l'orientation des trous.
 Assemblez d'abord les écrous en T avec un marteau !
 Assurez-vous que l'assemblage soit bien droit.

Tenga en cuenta la orientación de los orificios.
 ¡Monte primero las tuercas para clavar (t-nut) con un martillo!
 Asegúrese de que el conjunto esté en perpendicular.

Ausrichtung der Bohrungen beachten.
 Einschlagmütern zuerst mithilfe eines Hammers einschlagen!
 Die Bauteile müssen sich im rechten Winkel zueinander befinden.

Prestare attenzione all'orientamento dei fori.
 Assemblare prima i dadi a T con il martello!
 Accertarsi che l'assemblato sia in squadra.

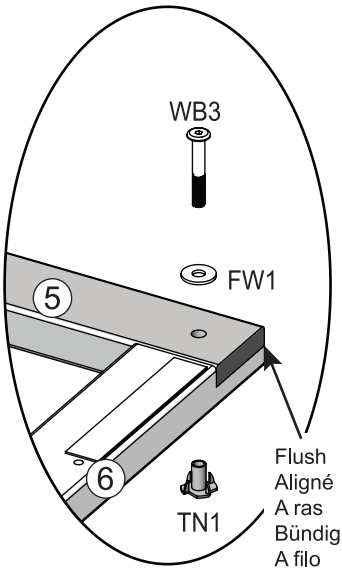

10

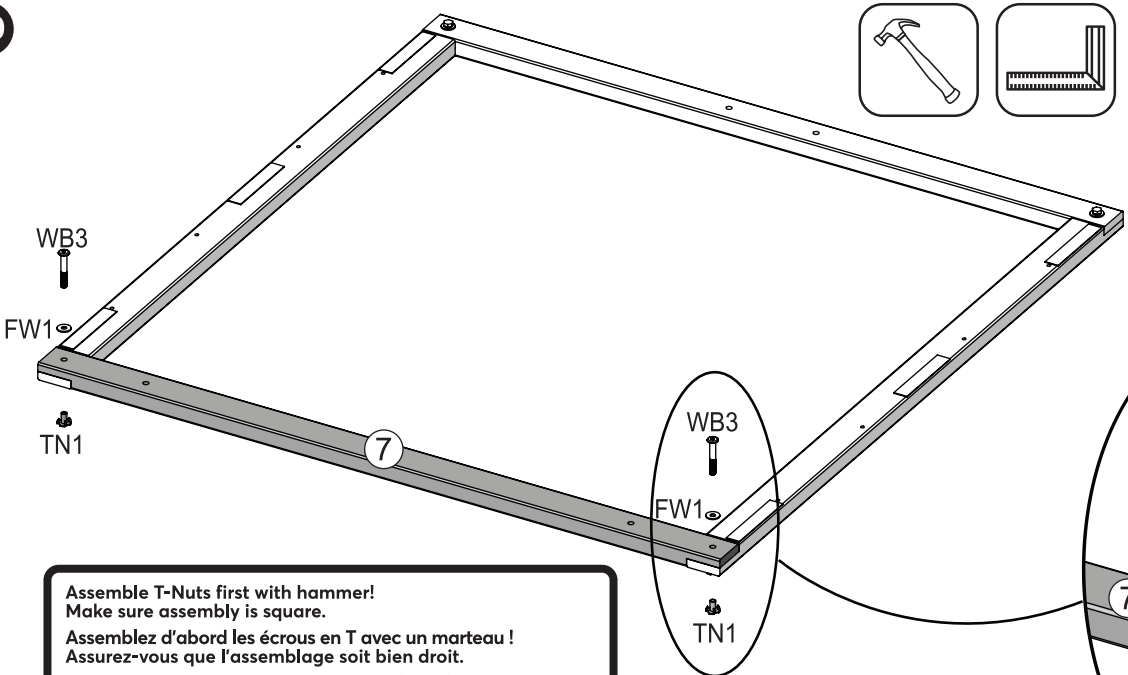

- 1 x 7

- 2 x WB3
- 2 x FW1
- 2 x TN1

Assemble T-Nuts first with hammer!
 Make sure assembly is square.

Assemblez d'abord les écrous en T avec un marteau !
 Assurez-vous que l'assemblage soit bien droit.

¡Monte primero las tuercas para clavar (t-nut) con un martillo!
 Asegúrese de que el conjunto esté en perpendicular.

Einschlagmütern zuerst mithilfe eines Hammers einschlagen!
 Die Bauteile müssen sich im rechten Winkel zueinander befinden.

Assemblare prima i dadi a T con il martello!
 Accertarsi che l'assemblato sia in squadra.

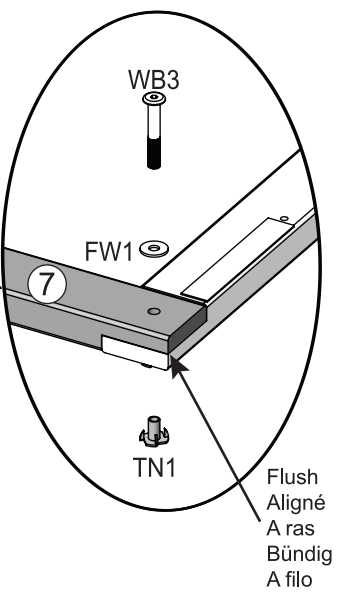

parts.kidkraft.com

customerservice@kidkraft.com
 1.800.933.0771
 972.385.0100

11

Flush
Aligné
A ras
Bündig
A filo

**Notice hole orientation.
Make sure assembly is square.**
**Faites attention à l'orientation des trous.
Assurez-vous que l'assemblage soit bien droit.**
**Tenga en cuenta la orientación de los orificios.
Asegúrese de que el conjunto esté en perpendicular.**
**Ausrichtung der Bohrungen beachten.
Die Bauteile müssen sich im rechten Winkel zueinander befinden.**
**Prestare attenzione all'orientamento dei fori.
Accertarsi che l'assemblato sia in squadra.**

8 x S15

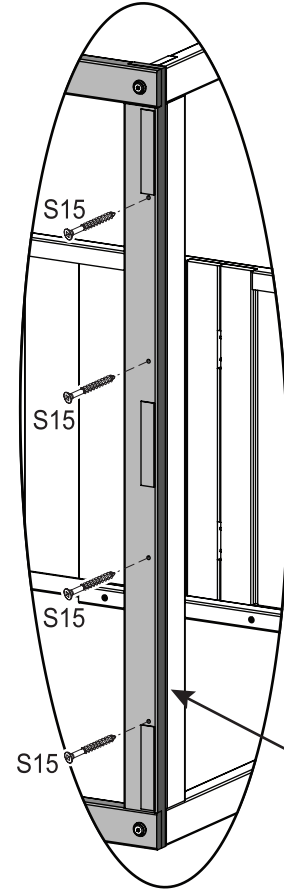
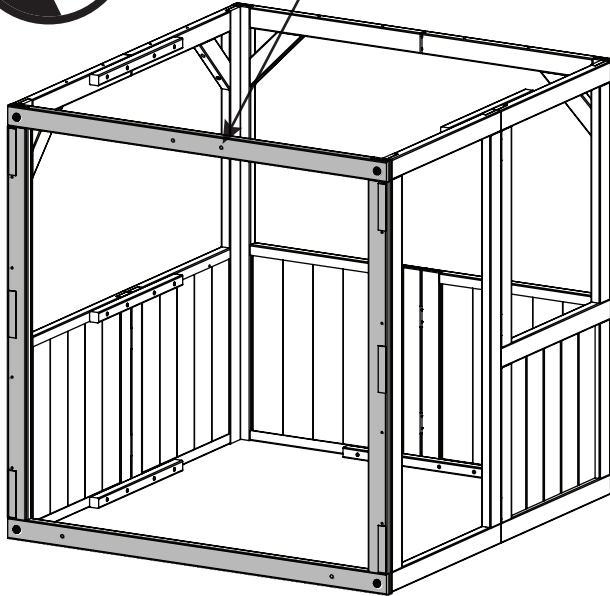
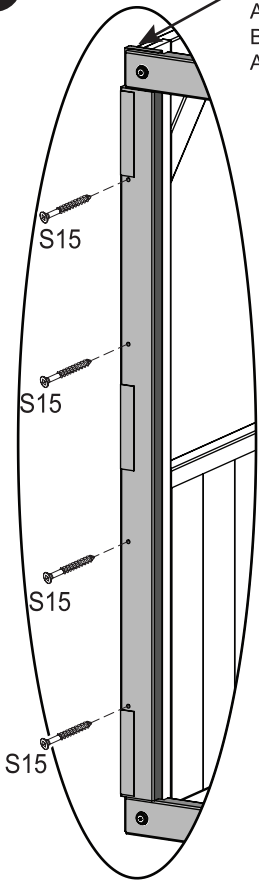

Flush
Aligné
A ras
Bündig
A filo

12

**Hammer T-Nuts into the holes as shown!
Enfoncez les écrous en T dans les trous comme indiqué !
Coloca las tuercas en T en los agujeros con un martillo como se muestra.
Hämmere die T-Muttern wie gezeigt in die Löcher!
Martellare i dadi a T nei fori come mostrato!**



2 x 8

2 x 9

8 x TN1

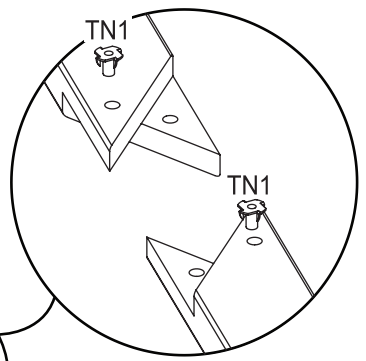
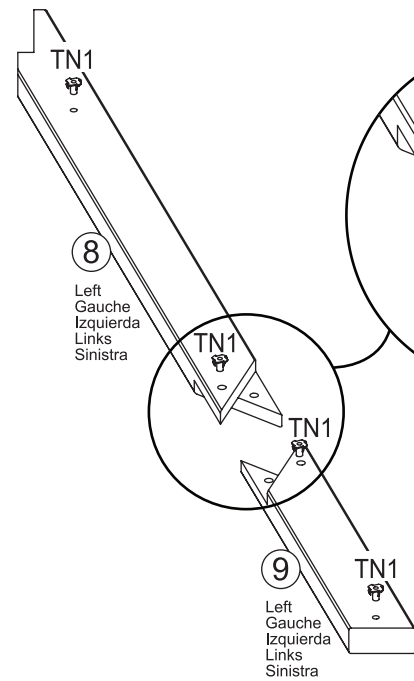
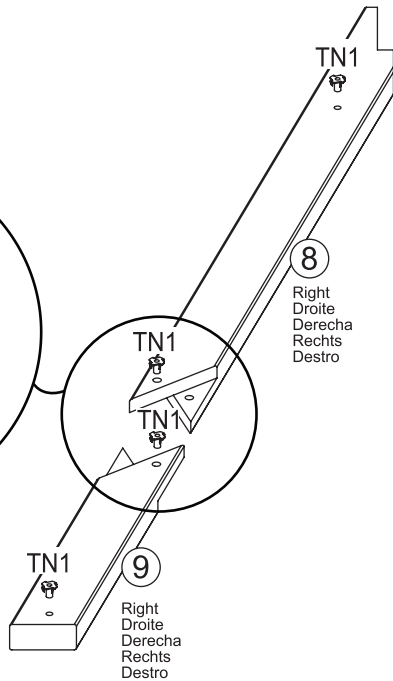
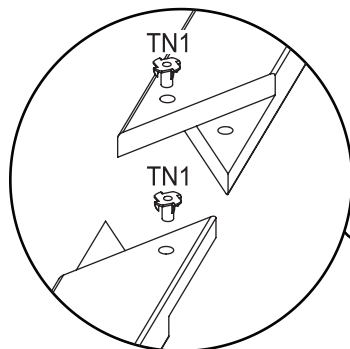



1 x 10

4 x H2
4 x LW1
4 x FW1

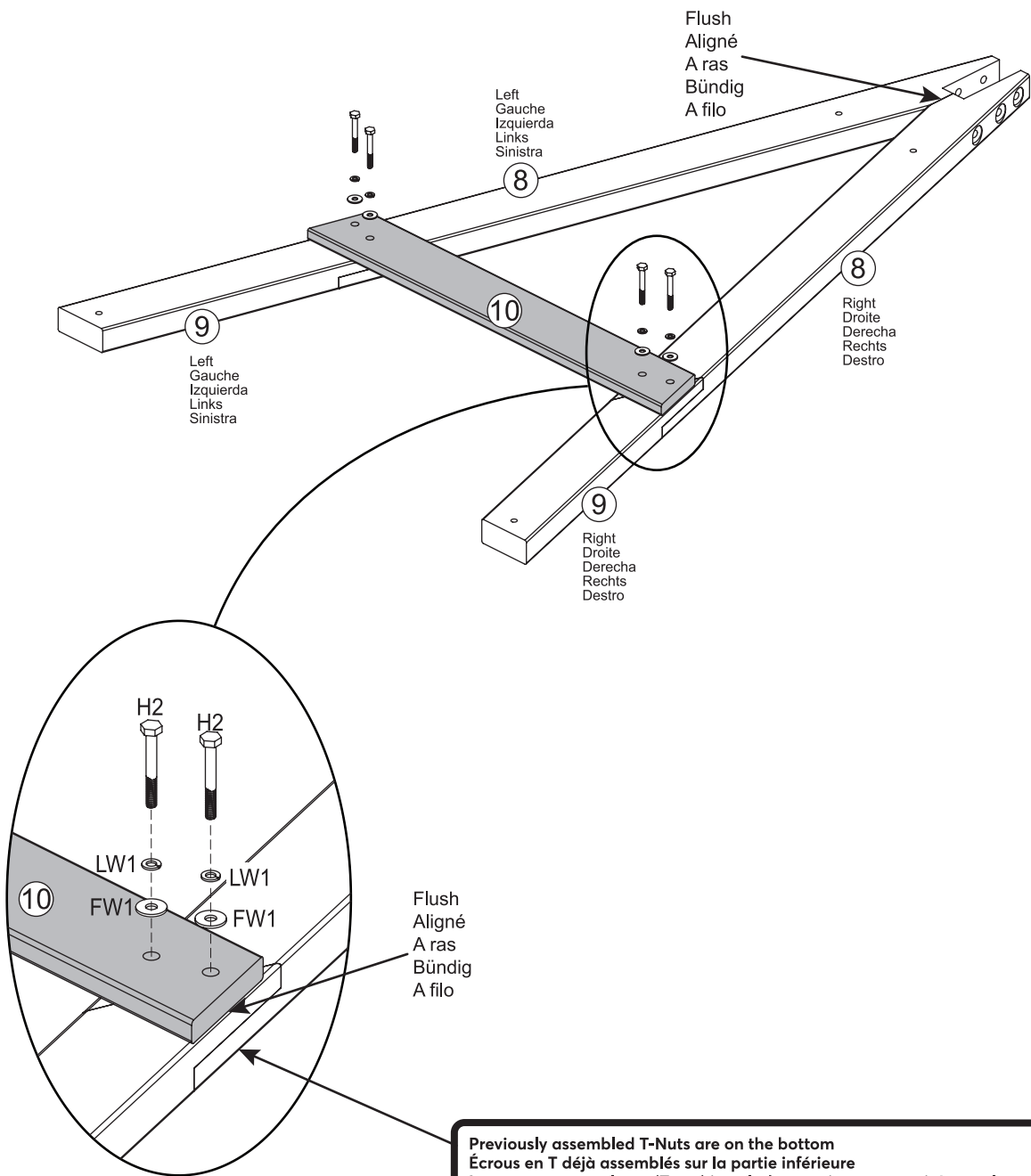

Previously assembled T-Nuts are on the bottom
Écrous en T déjà assemblés sur la partie inférieure
Las tuercas para clavar (T-nut) instaladas previamente se sitúan en la parte inferior.
Vorher befestigte Einschlagmuttern sitzen unten.
I dadi a T fissati in precedenza sono sul fondo



14



4 x H3
4 x LW1
4 x FW1

Previously assembled T-nuts are on the back side
Les écrous en T précédemment assemblés se situent sur la face arrière.
Las tuercas en T premontadas se encuentran en la parte posterior.
Die bereits montierten T-Muttern befinden sich auf der Rückseite.
I dadi a T precedentemente assemblati sono sul retro.

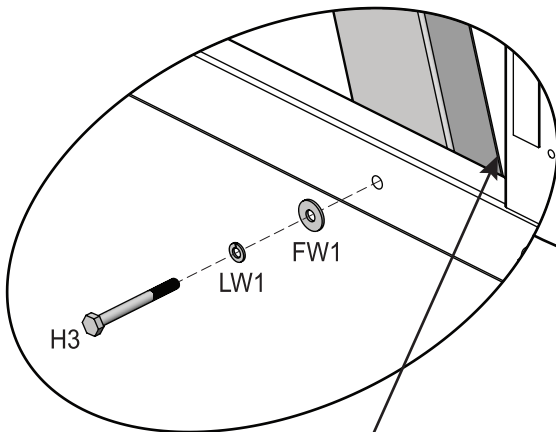
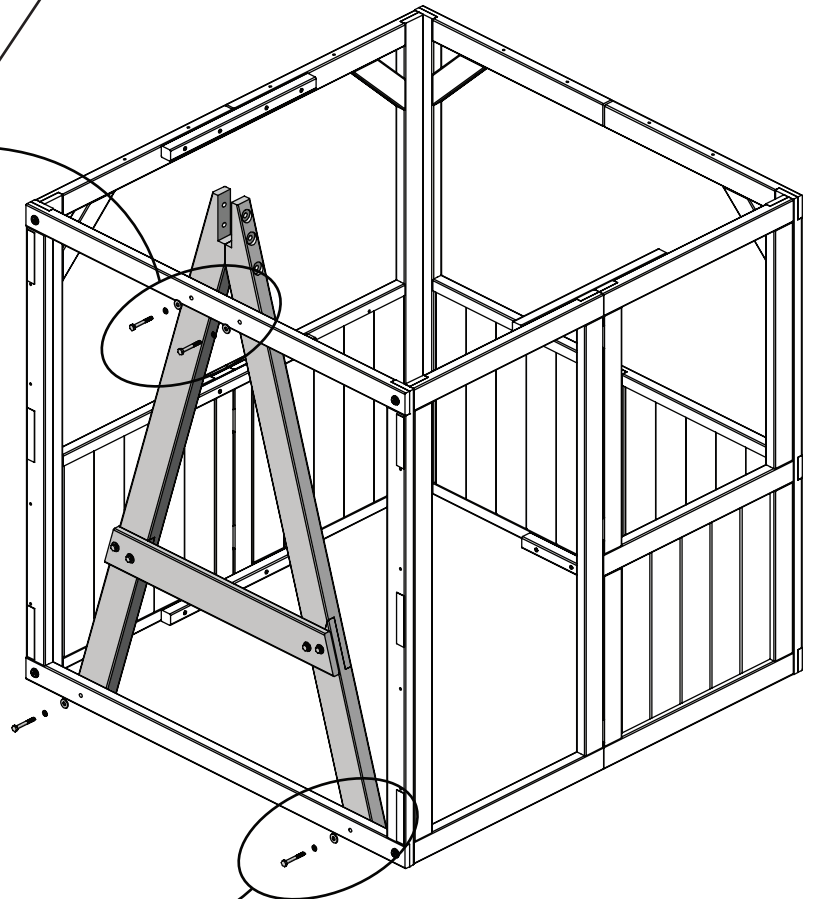
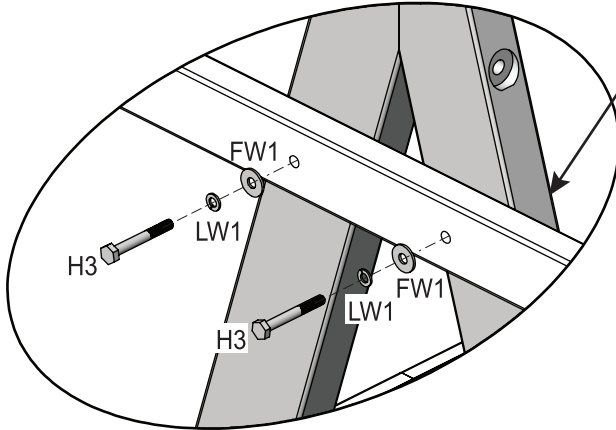

Previously assembled T-nuts are on the back side
Les écrous en T précédemment assemblés se situent sur la face arrière.
Las tuercas en T premontadas se encuentran en la parte posterior.
Die bereits montierten T-Muttern befinden sich auf der Rückseite.
I dadi a T precedentemente assemblati sono sul retro.

europcustomerservice@kidkraft.com
+31 20 305 8620
M-F from 09:00 to 17:30 (GMT+1)

parts.kidkraft.eu



15

1 x 11

2 x SH1

Note the angled cut
 Noter les coupes obliques
 Tenga en cuenta los cortes en ángulo
 Schräge Schnitte beachten
 Prestare attenzione ai tagli inclinati

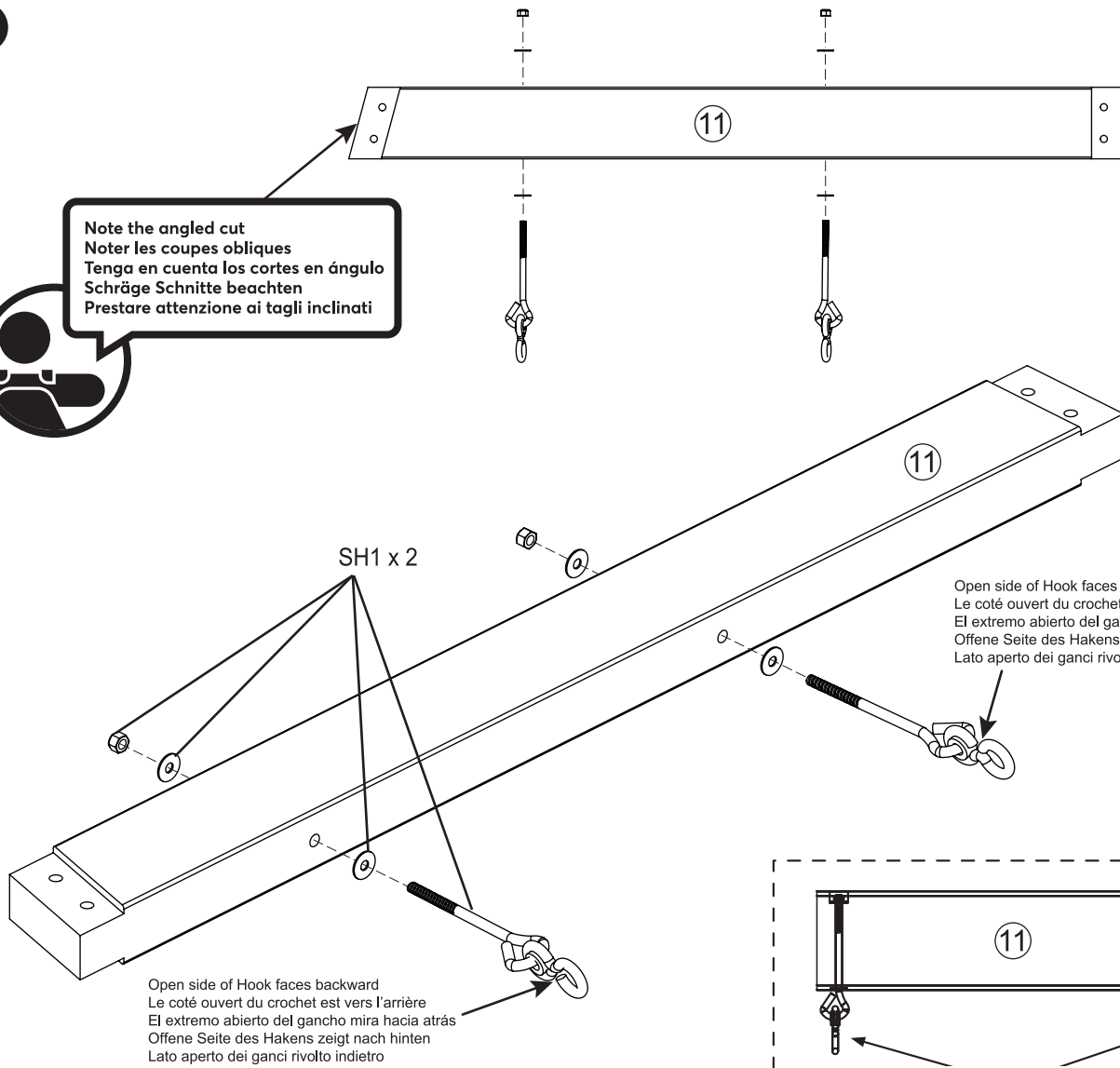

Open side of Hook faces backward
 Le coté ouvert du crochet est vers l'arrière
 El extremo abierto del gancho mira hacia atrás
 Offene Seite des Hakens zeigt nach hinten
 Lato aperto dei ganci rivolto indietro

Open side of Hook faces forward
 Le coté ouvert du crochet est vers l'avant
 El extremo abierto del gancho mira hacia delante
 Offene Seite des Hakens zeigt nach vorne
 Lato aperto dei ganci rivolto in avanti

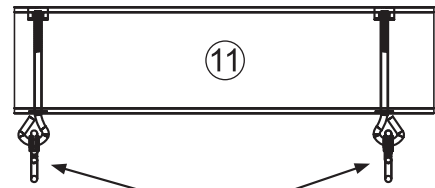

Make sure triangle is tight against beam
 Assurez-vous que le triangle est bien serré contre la poutre
 Compruebe que el triángulo esté ajustado contra el travesaño.
 Dreieck muss fest am Balken befestigt werden.
 Accertarsi che la piastra triangolare sia in battuta con l'asse

WARNING: For your child's safety, orientate the swing hangers as shown to ensure your swing will have proper swing motion when installed. Failure to do so could result in premature failure of the swing hanger or swing chain.

ATTENTION : Pour la sécurité de votre enfant, orientez les suspentes de la balançoire comme indiqué pour assurer un mouvement de balancement approprié, une fois la balançoire installée. Le non-respect de cette consigne peut entraîner la défaillance prématurée de la suspente ou de la chaîne de la balançoire.

ADVERTENCIA: Por la seguridad de los niños, oriente los soportes para columpio como se muestra en las figuras. De este modo, el columpio se moverá correctamente cuando esté instalado. De no ser así, podría producirse un fallo prematuro en el soporte para columpio o la cadena.

WARNUNG: Aus Sicherheitsgründen müssen die Schaukelabhängler wie in der Abbildung gezeigt ausgerichtet werden, um eine korrekte Schaukelbewegung zu gewährleisten. Bei Nichtbefolgung dieser Anweisung kann es zum vorzeitigen Versagen der Schaukelabhängler oder der Schaukelkette kommen.

AVVERTENZA: per la sicurezza dei bambini, orientare i ganci per altalena come mostrato in figura per garantire un movimento sicuro dell'altalena una volta montata. In caso contrario si potrebbe assistere a un guasto prematuro del gancio o della catena dell'altalena.

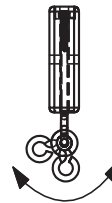

16

Hammer T-Nuts into the holes as shown!
 Enfoncez les écrous en T dans les trous comme indiqué !
 Coloca las tuercas en T en los agujeros con un martillo como se muestra.
 Hämmere die T-Muttern wie gezeigt in die Löcher!
 Martellare i dadi a T nei fori come mostrato!



- 1 x 12L
- 1 x 12R
- 2 x 13
- 4 x TN1

Note the Angle Orientation.
 Notez l'orientation de l'angle.
 Tenga en cuenta la orientación del ángulo.
 Ausrichtung der Winkel beachten.
 Prestare attenzione all'orientamento dell'angolo.

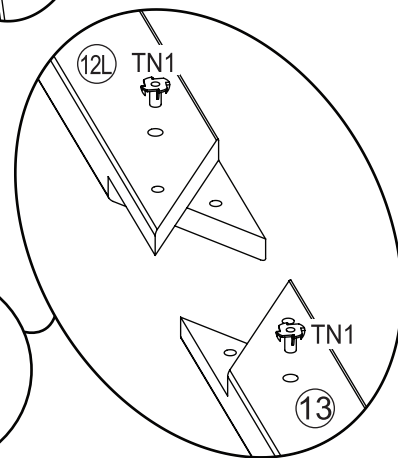
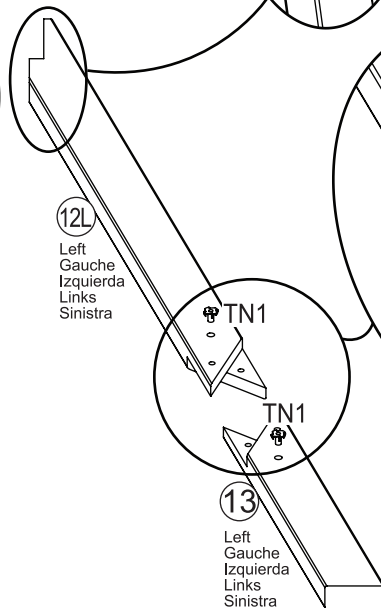
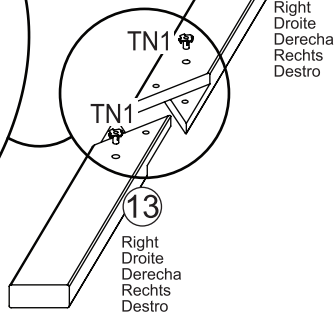
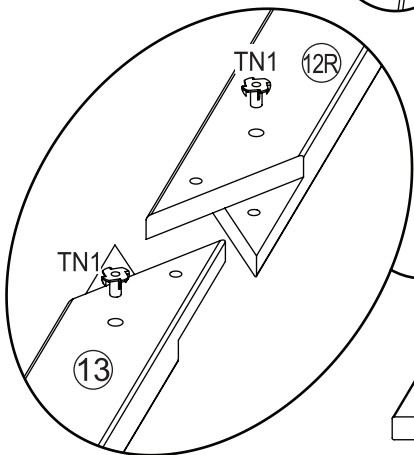
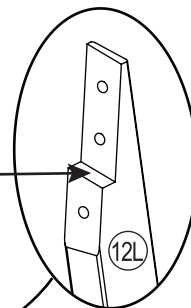
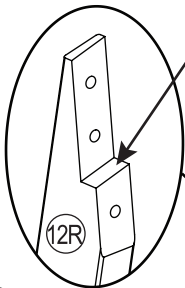

17



- 2 x 9211612
- 4 x H1
- 4 x LW1
- 4 x FW1

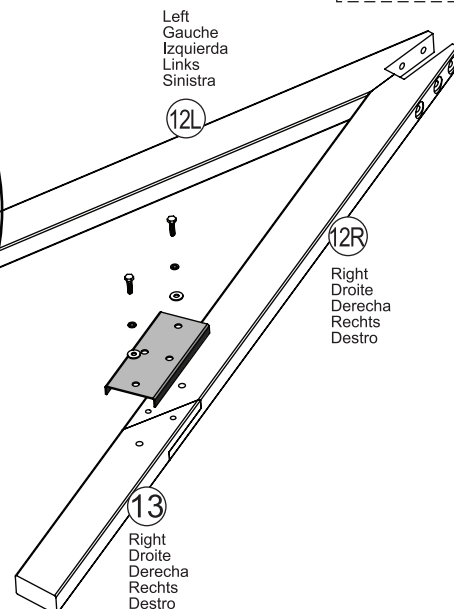
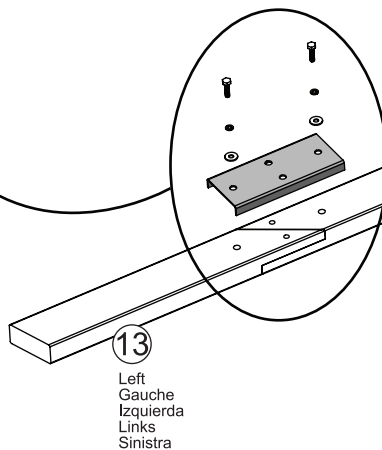
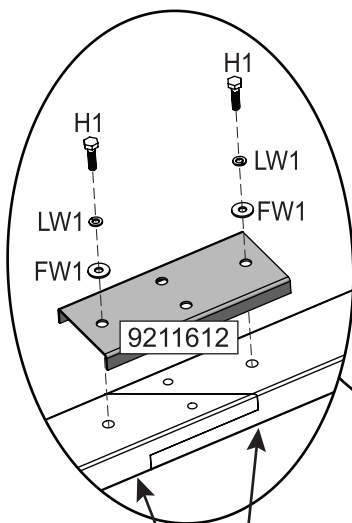

Previously assembled T-Nuts are on the bottom
 Écrous en T déjà assemblés sur la partie inférieure
 Las tuercas para clavar (T-nut) instaladas previamente se sitúan en la parte inferior.
 Vorher befestigte Einschlagmuttern sitzen unten.
 I dadi a T fissati in precedenza sono sul fondo



18



1 x 10

4 x TN1

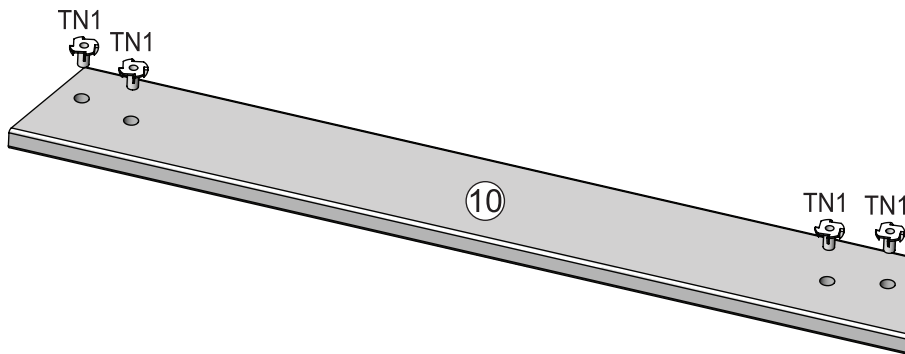

Hammer T-Nuts into the holes as shown!
 Enfoncez les écrous en T dans les trous comme indiqué !
 Coloca las tuercas en T en los agujeros con un martillo como se muestra.
 Hämmere die T-Muttern wie gezeigt in die Löcher!
 Martellare i dadi a T nei fori come mostrato!



19

Flush
 Aligné
 A ras
 Bündig
 A filo



1 x 10

4 x H2
 4 x LW1
 4 x FW1

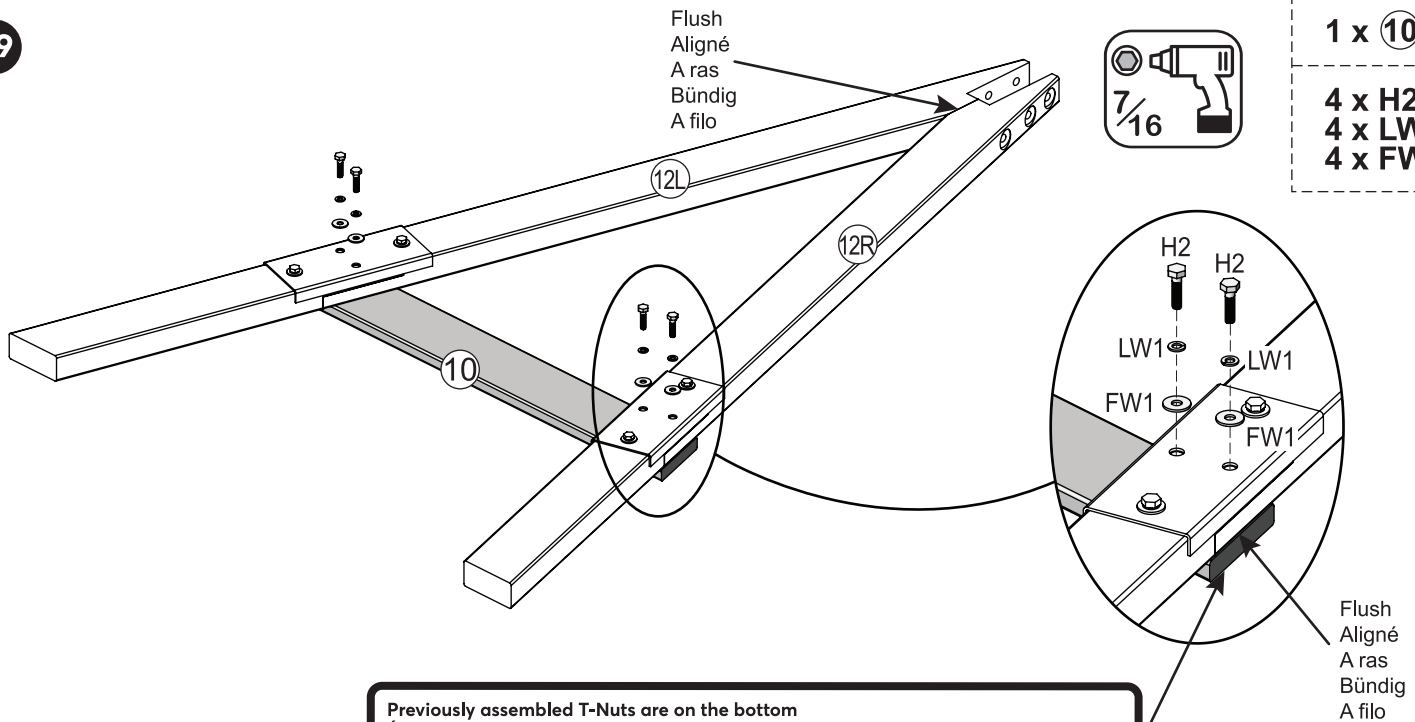

Previously assembled T-Nuts are on the bottom
 Écrous en T déjà assemblés sur la partie inférieure
 Las tuercas para clavar (T-nut) instaladas previamente se sitúan en la parte inferior.
 Vorher befestigte Einschlagmuttern sitzen unten.
 I dadi a T fissati in precedenza sono sul fondo





- 1 x G13
- 1 x LN2
- 1 x LW2
- 2 x FW2
- 1 x H4
- 1 x H6
- 2 x LN1
- 2 x LW1
- 4 x FW1

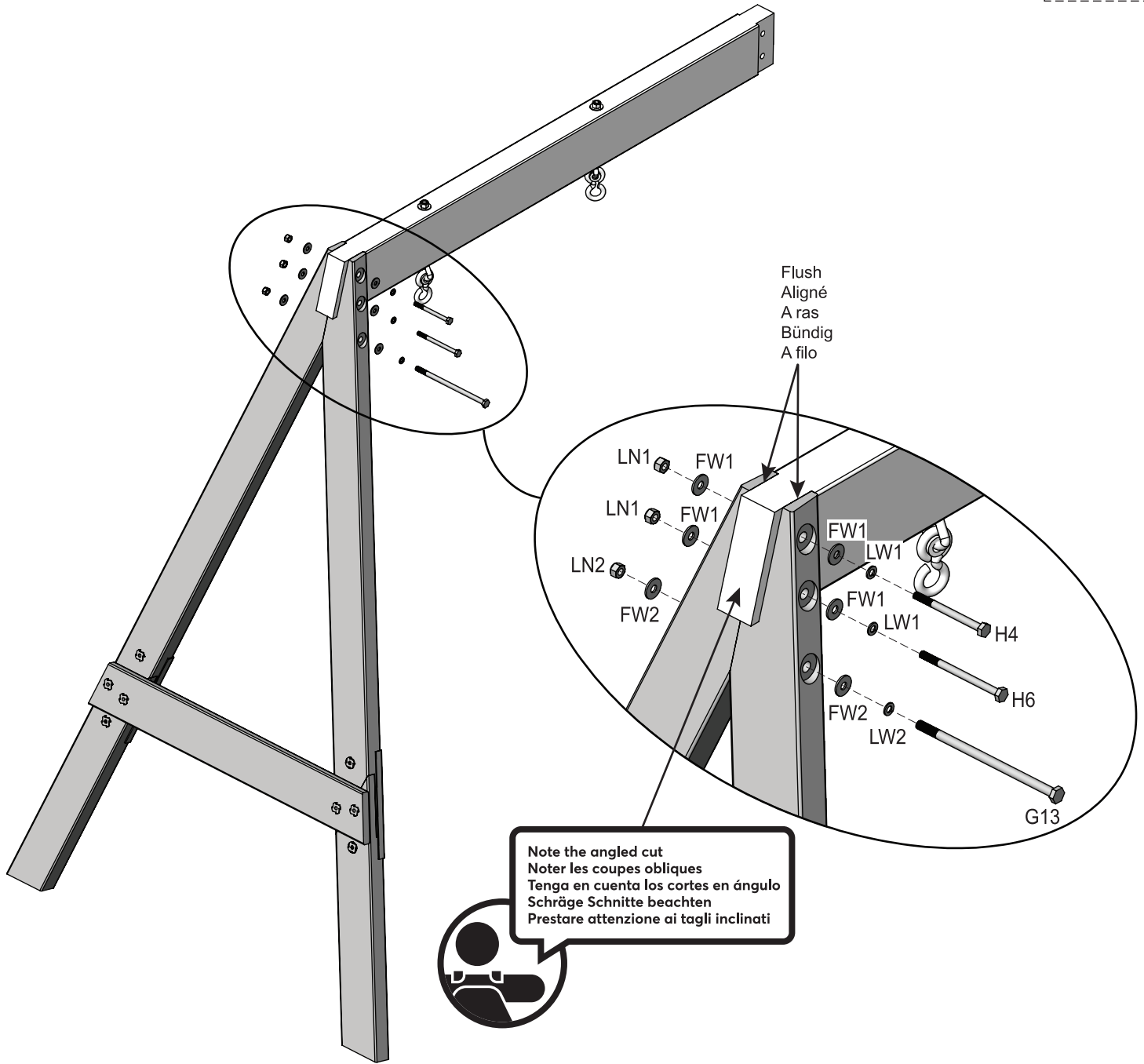

Note the angled cut
 Noter les coupes obliques
 Tenga en cuenta los cortes en ángulo
 Schräge Schnitte beachten
 Prestare attenzione ai tagli inclinati





- 1 x H4
- 1 x H6
- 2 x LN1
- 2 x LW1
- 4 x FW1
- 1 x G13
- 1 x LN2
- 1 x LW2
- 2 x FW2

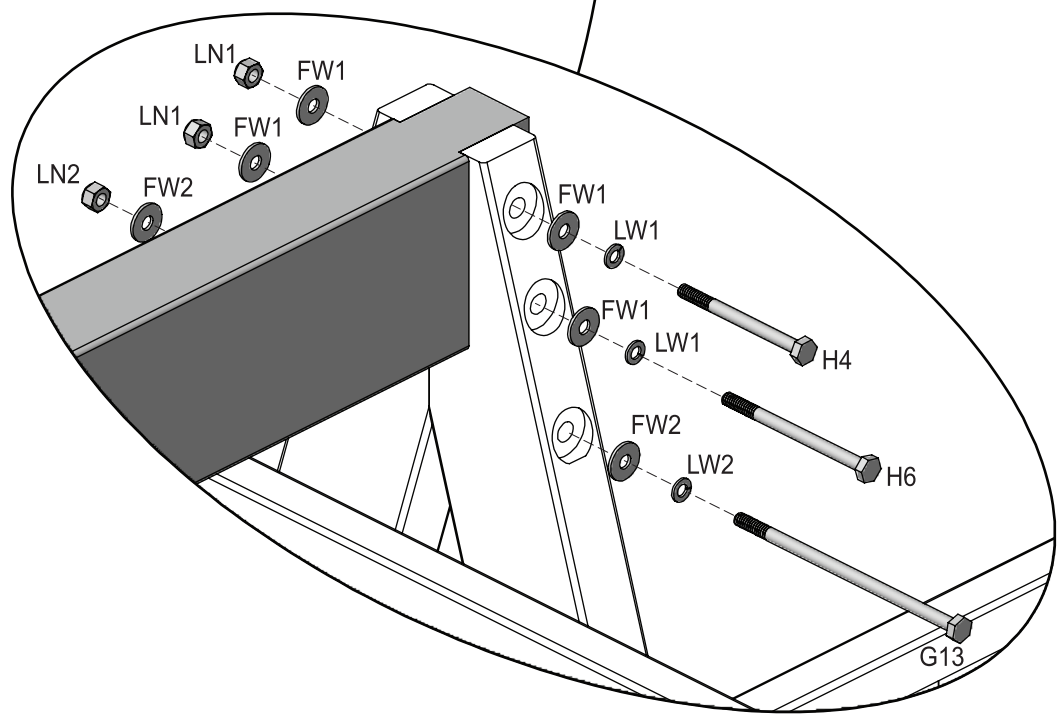
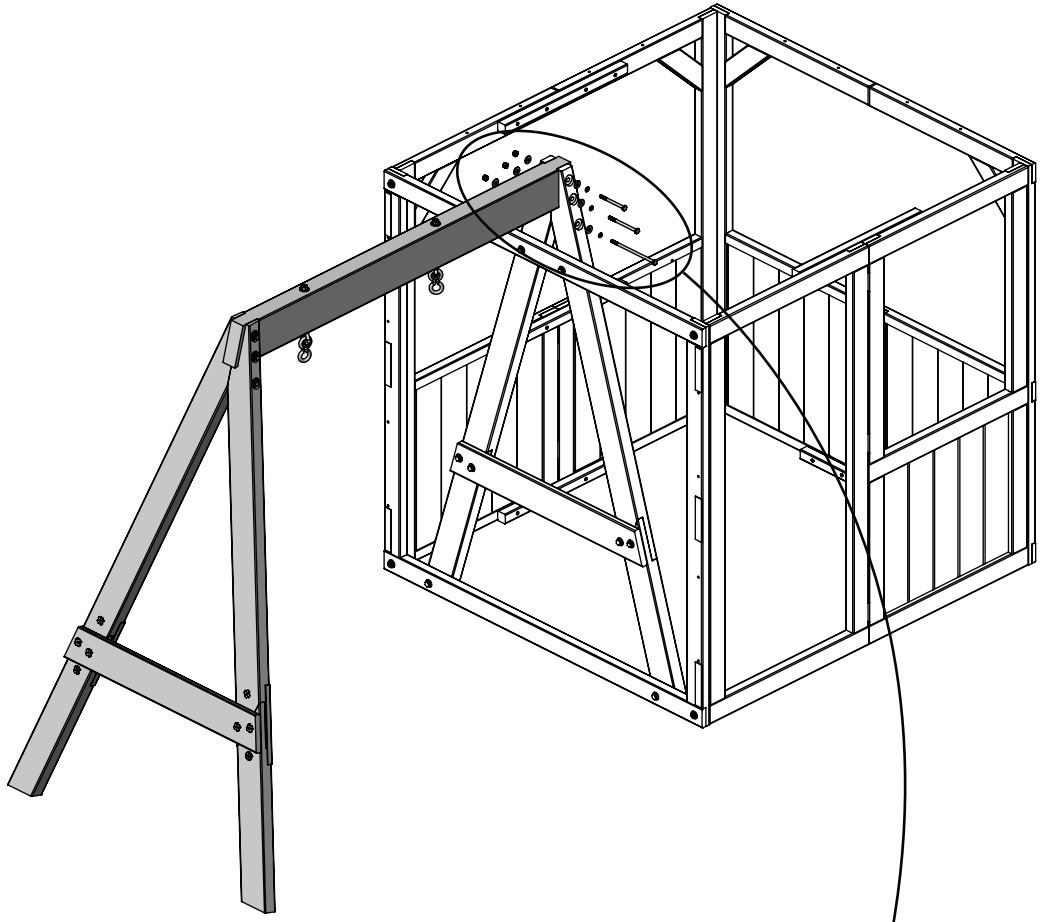

22



1 x 14

1 x 15

1 x S3

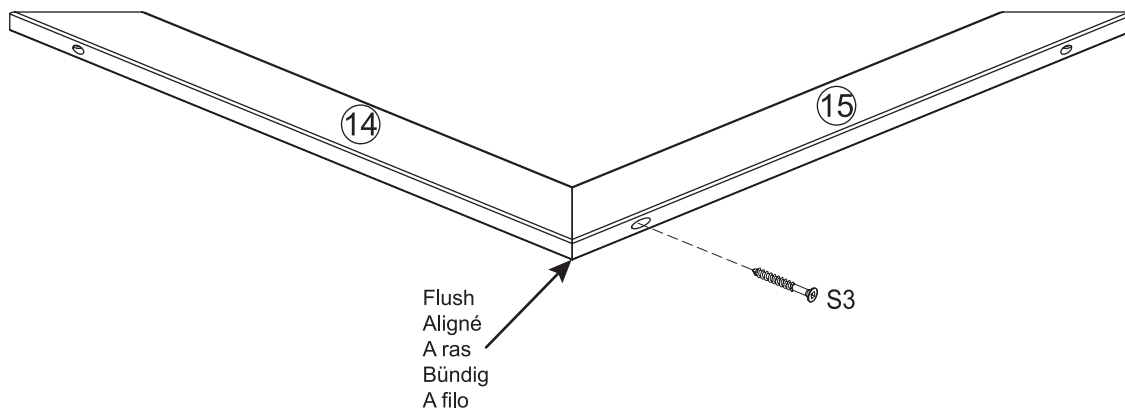

23



2 x S4

Flush
Aligné
A ras
Bündig
A filo

S4

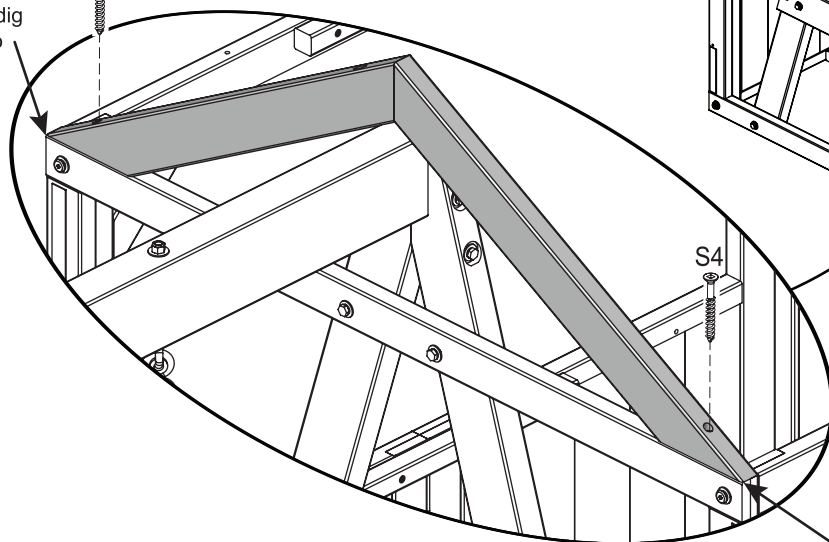

Flush
Aligné
A ras
Bündig
A filo

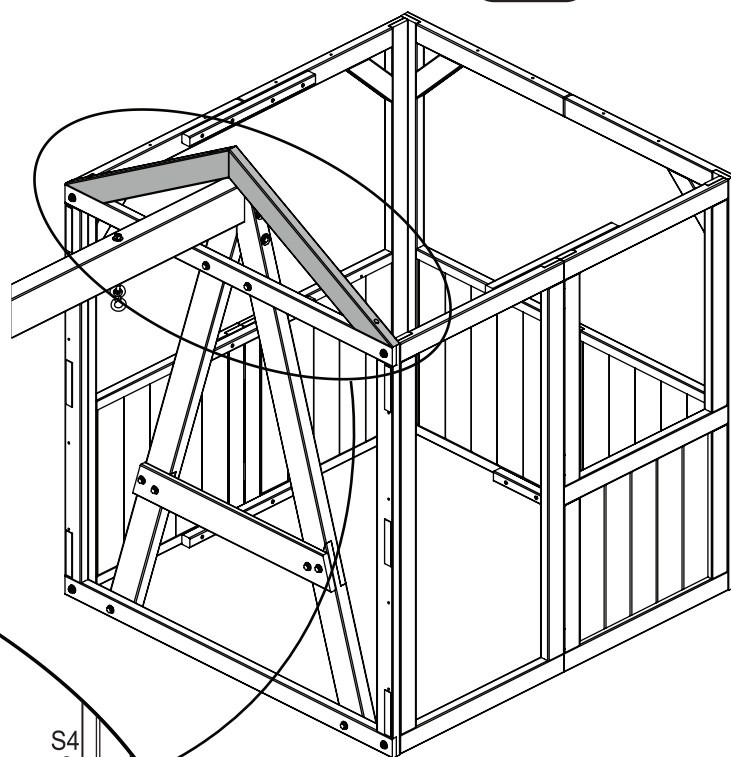

24



1 x 16

1 x 17

1 x S3

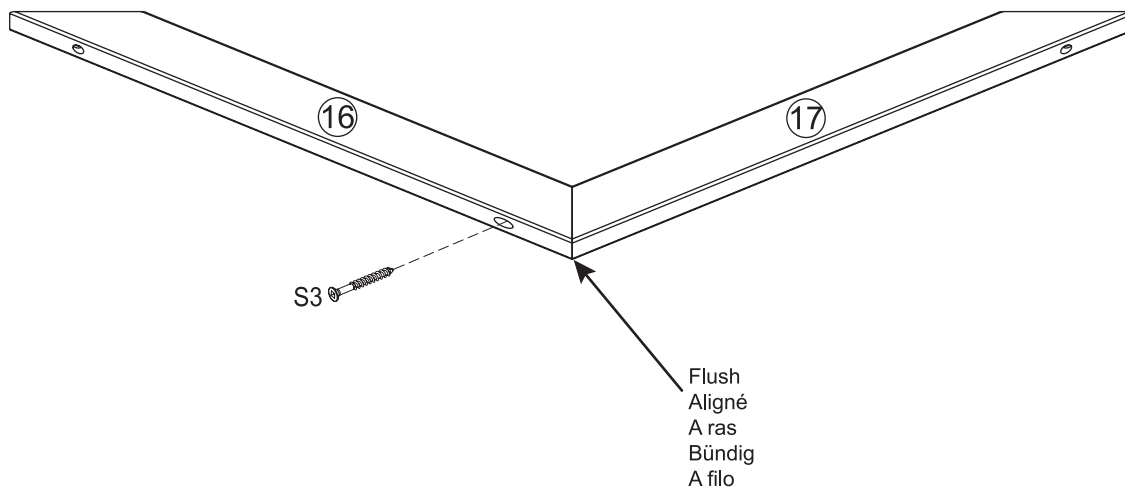

25

2 x 18

1 x 19

1 x 20

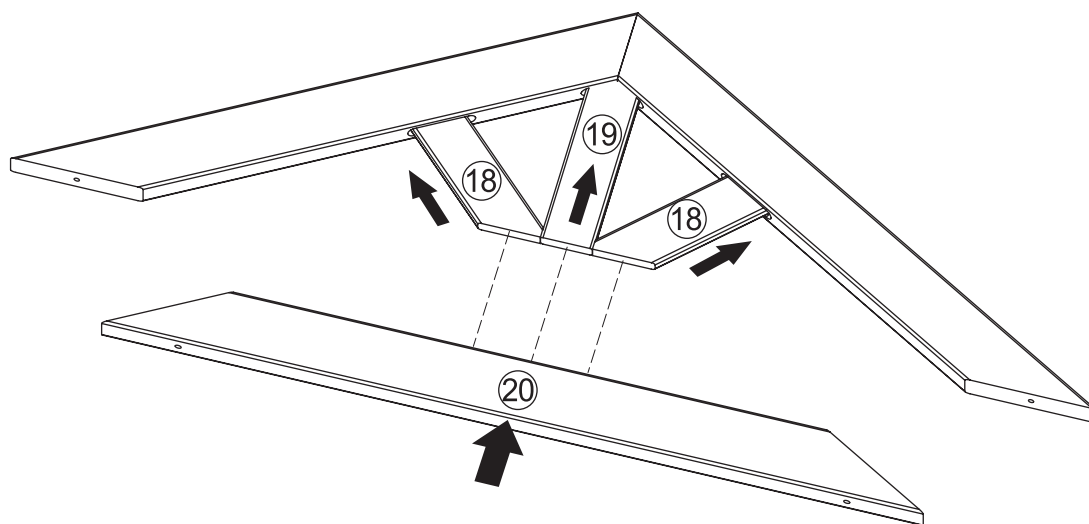

26



2 x S3

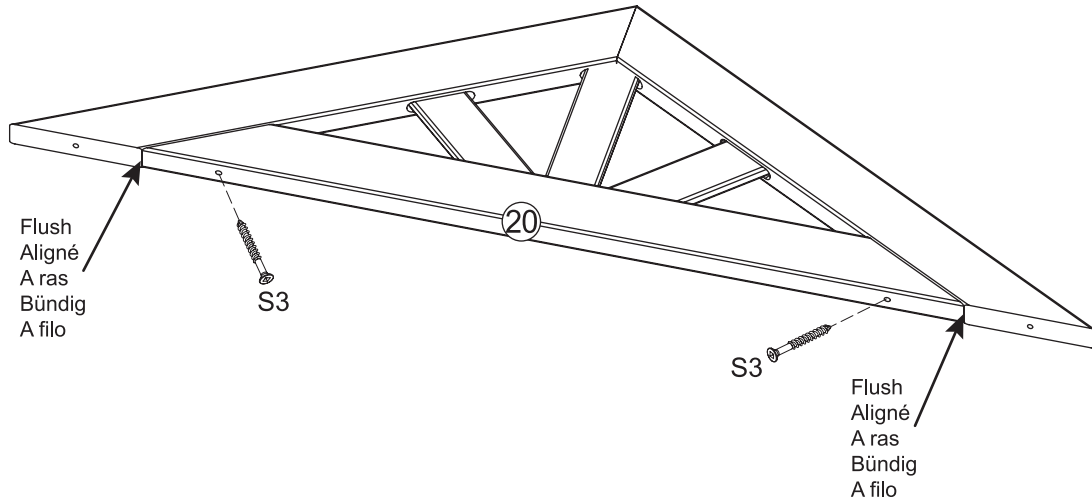

27



2 x S4

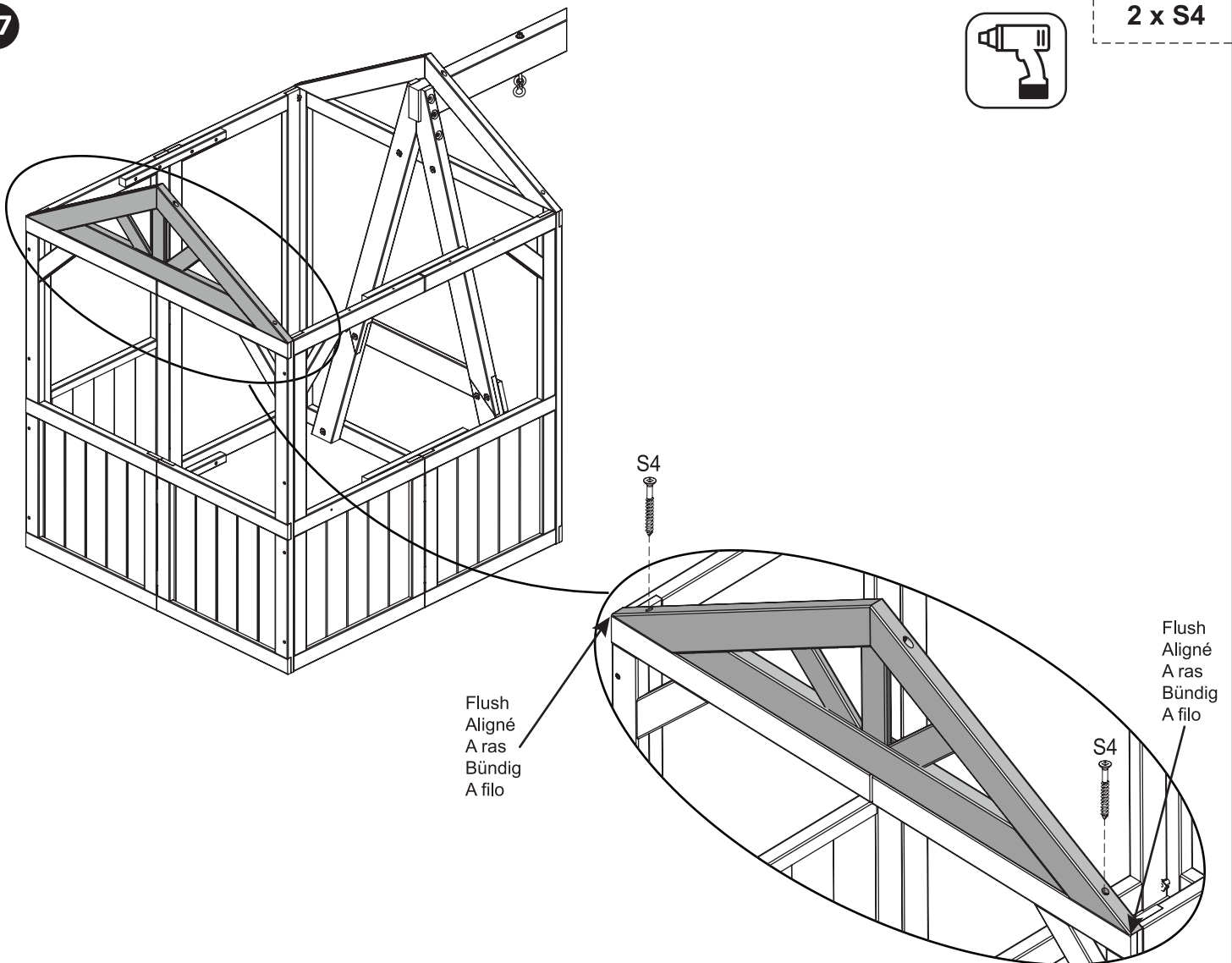

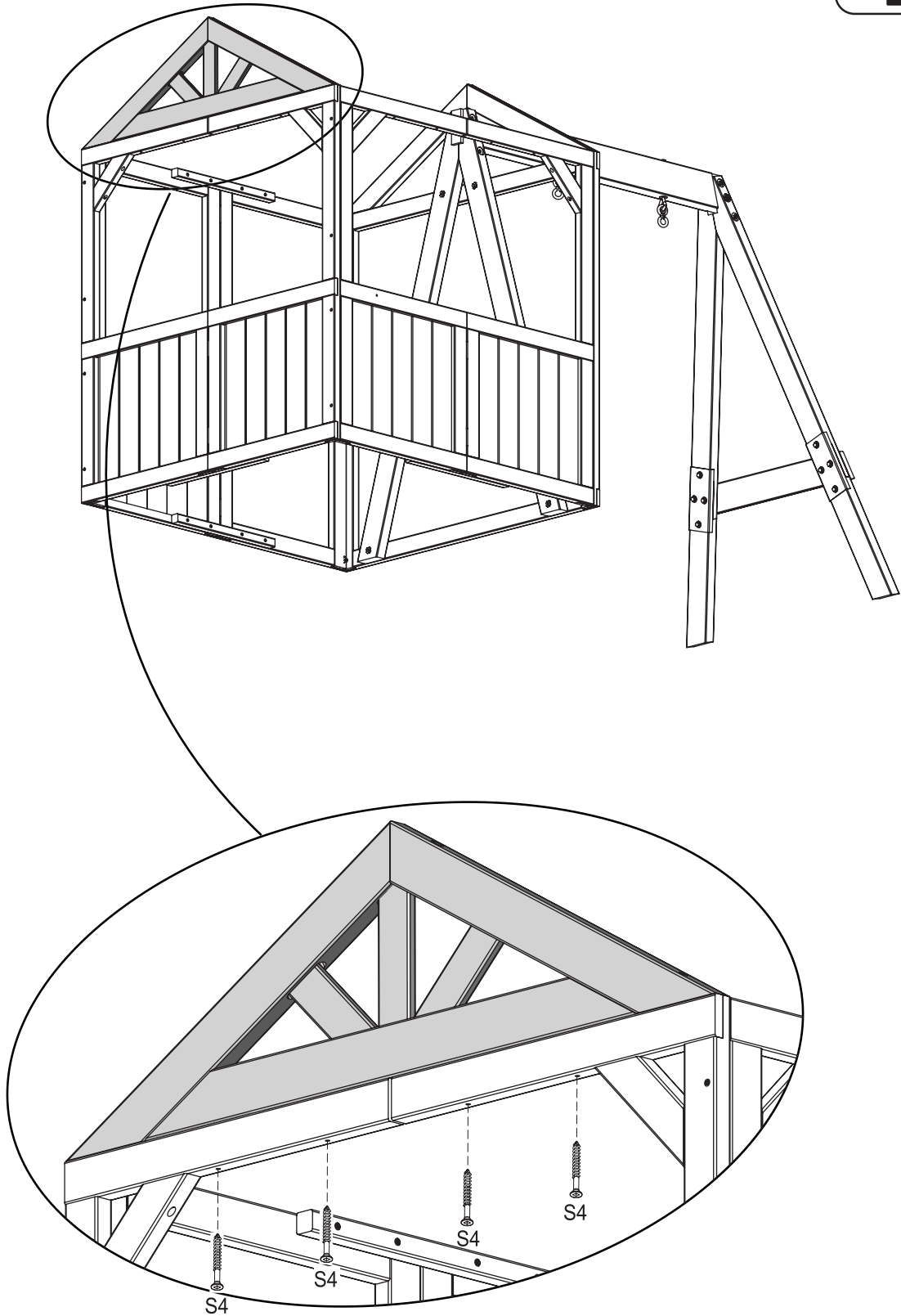

29

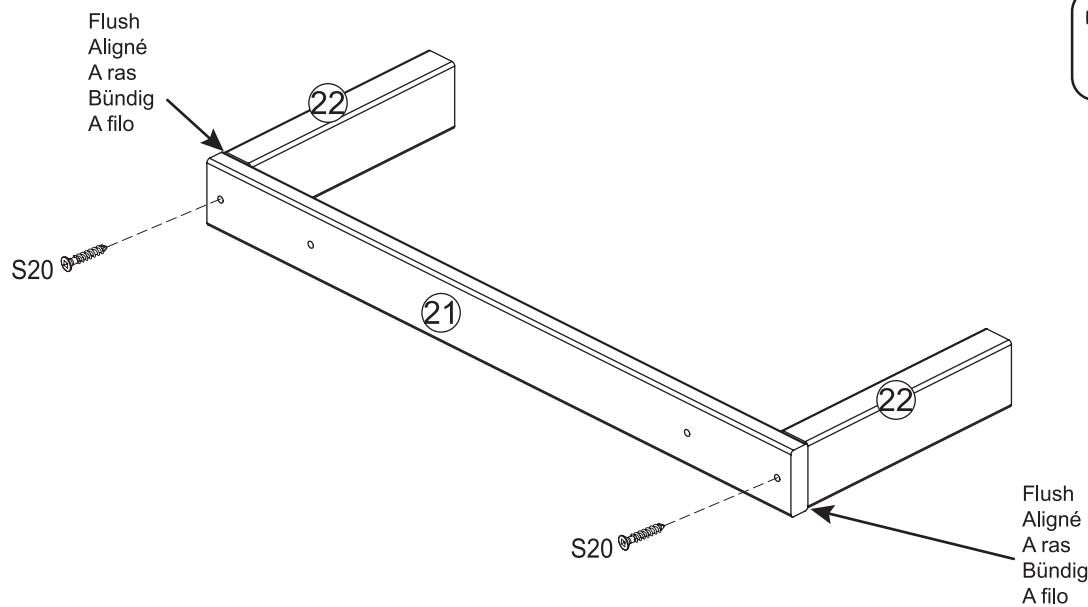

- 1 x 21
- 2 x 22
- 2 x S20

30

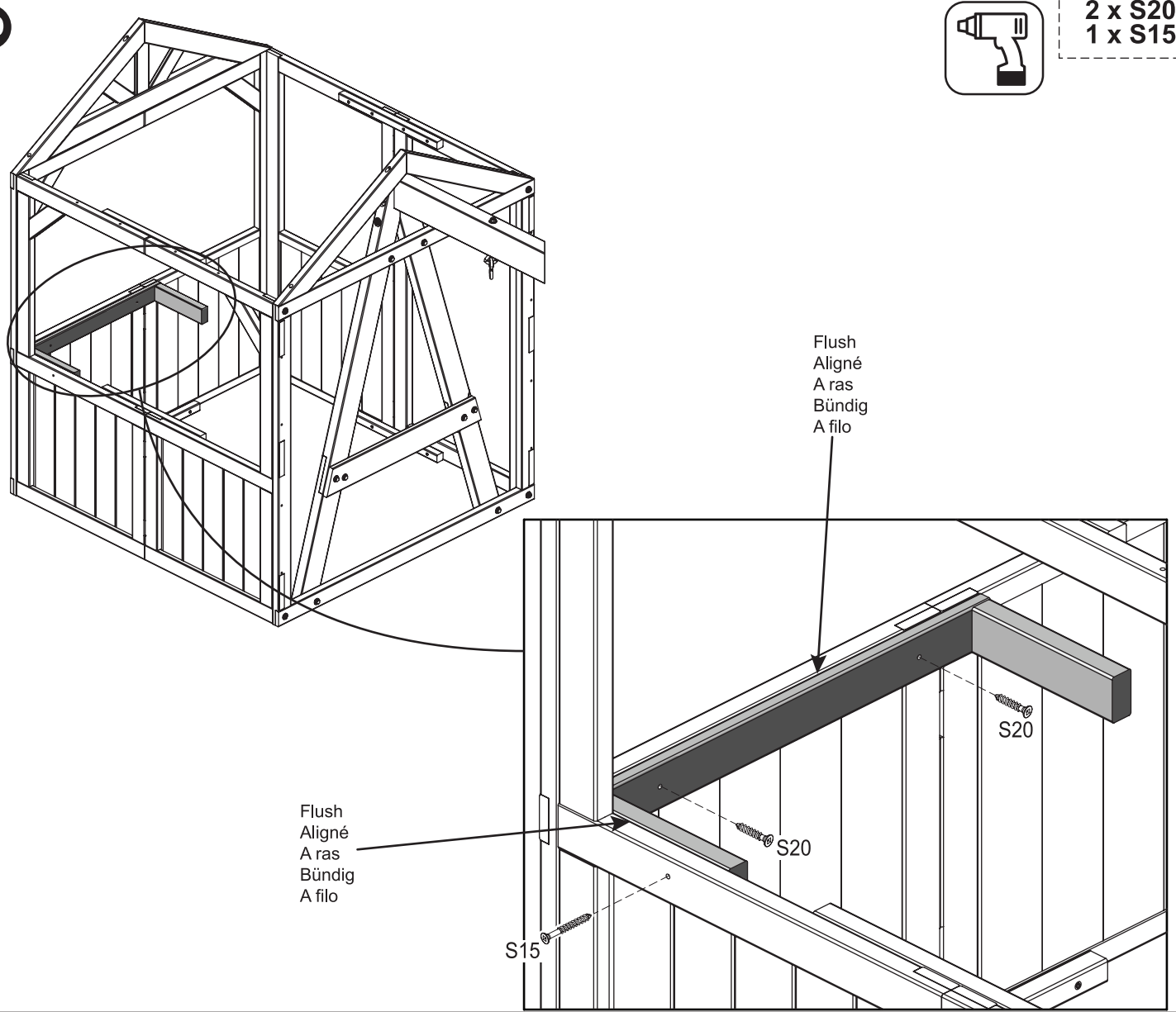

- 2 x S20
- 1 x S15

europcustomerservice@kidkraft.com
 +31 20 305 8620
 M-F from 09:00 to 17:30 (GMT+1)

parts.kidkraft.eu



31



1 x 23

2 x S20

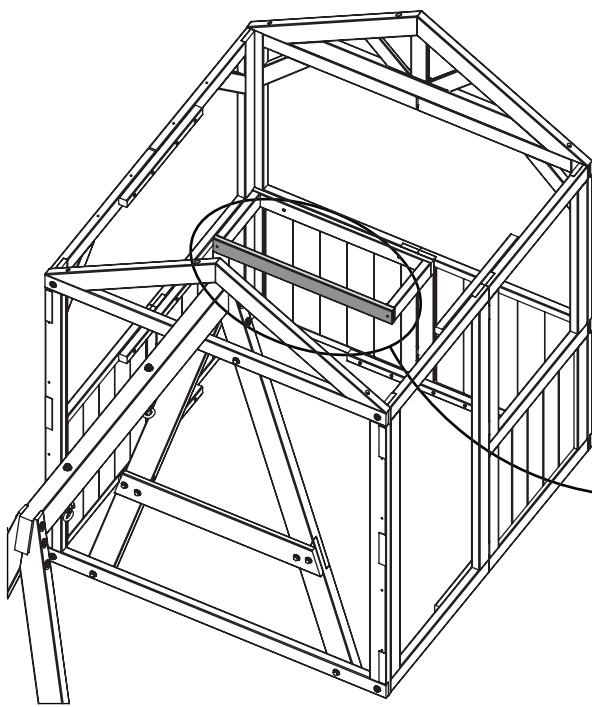

Flush
Aligné
A ras
Bündig
A filo

Flush
Aligné
A ras
Bündig
A filo

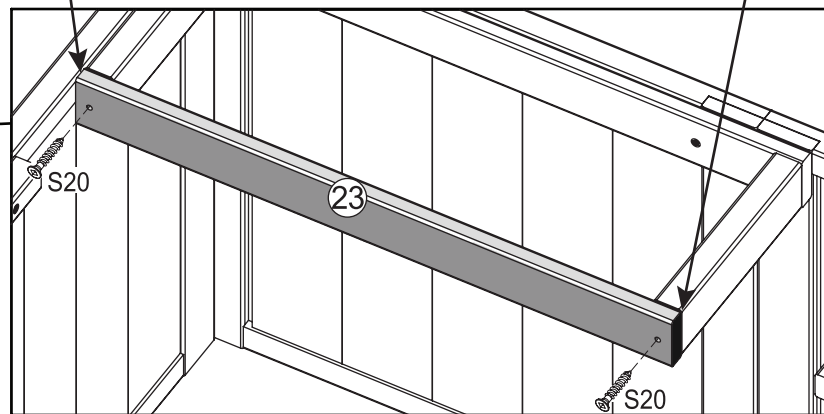

32



1 x 24

2 x S3

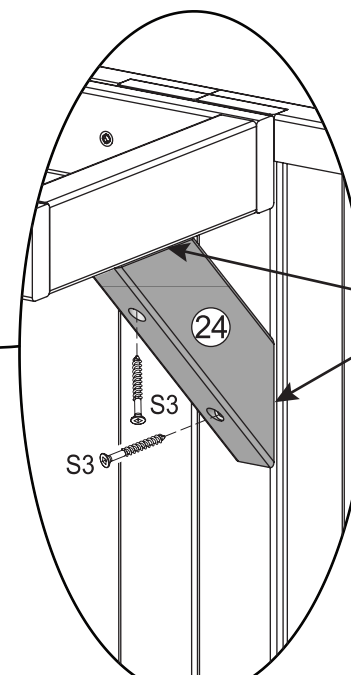
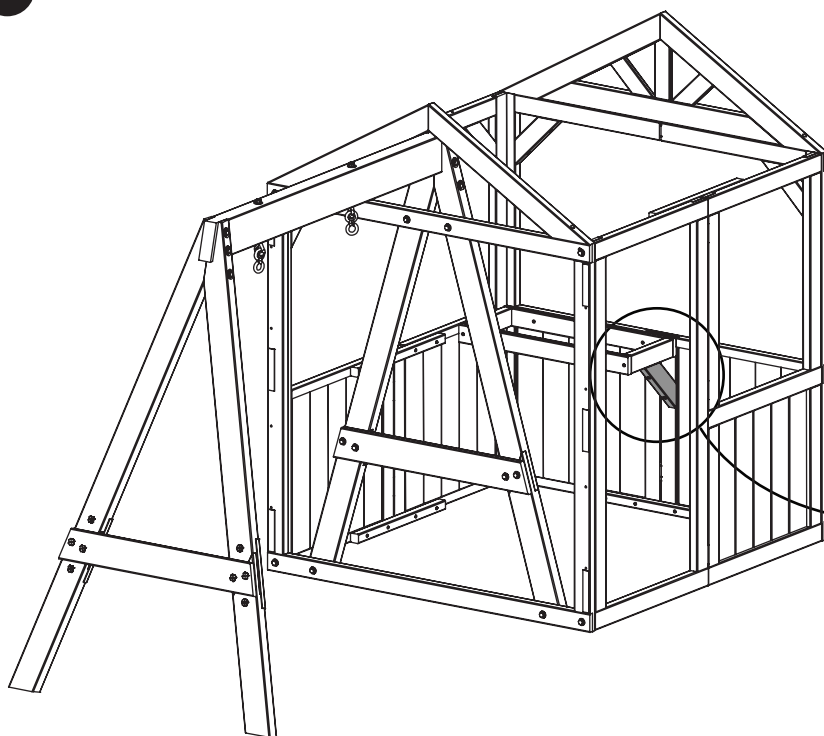

Flush
Aligné
A ras
Bündig
A filo

33



1 x 25
4 x S20

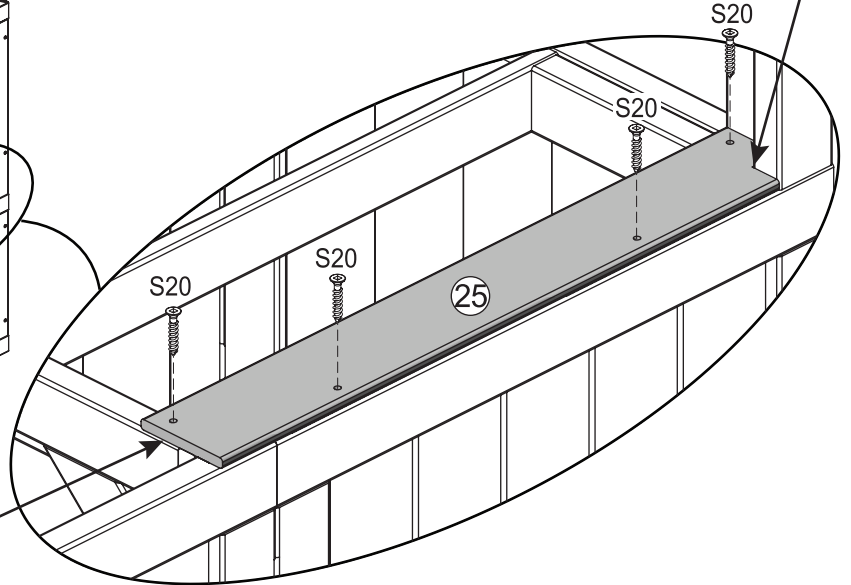
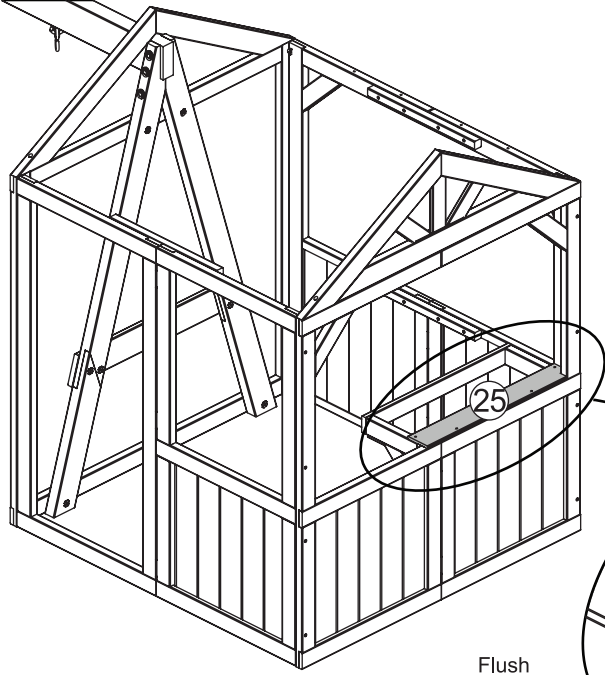

Tight
Serré
Apretado
Fest
Stretto

Flush
Aligné
A ras
Bündig
A filo

34



2 x 26
4 x S20

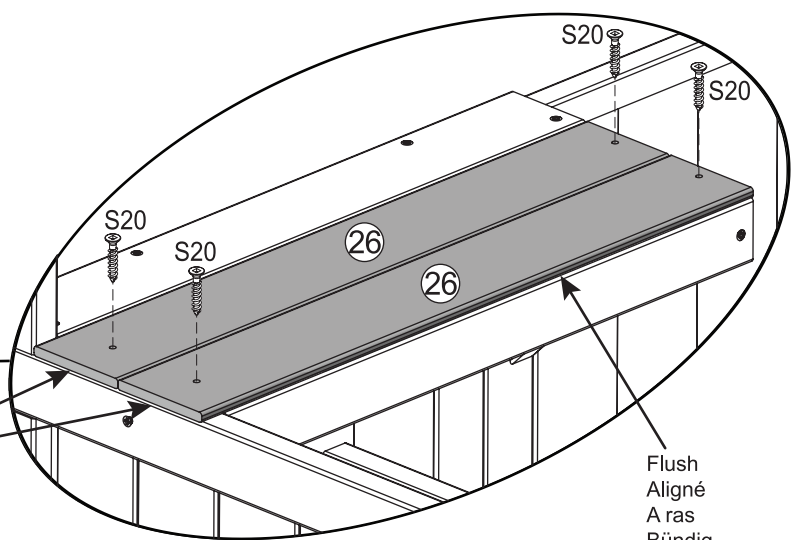
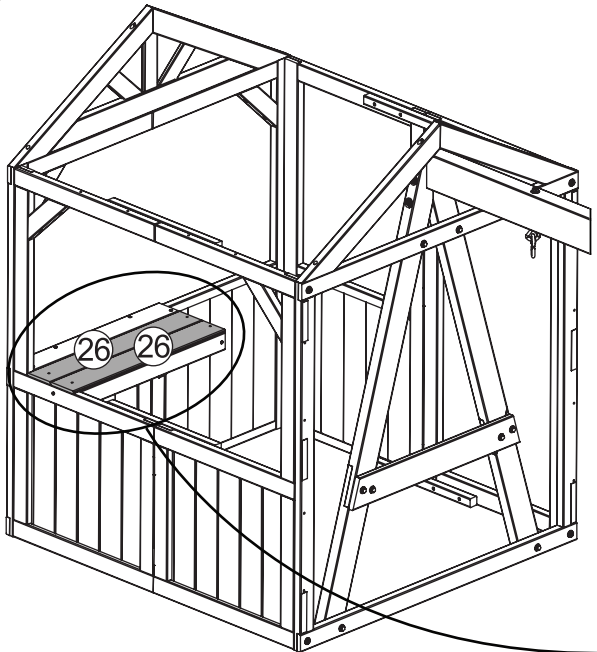

Flush
Aligné
A ras
Bündig
A filo

Flush
Aligné
A ras
Bündig
A filo

europcustomerservice@kidkraft.com
+31 20 305 8620
M-F from 09:00 to 17:30 (GMT+1)

parts.kidkraft.eu



35

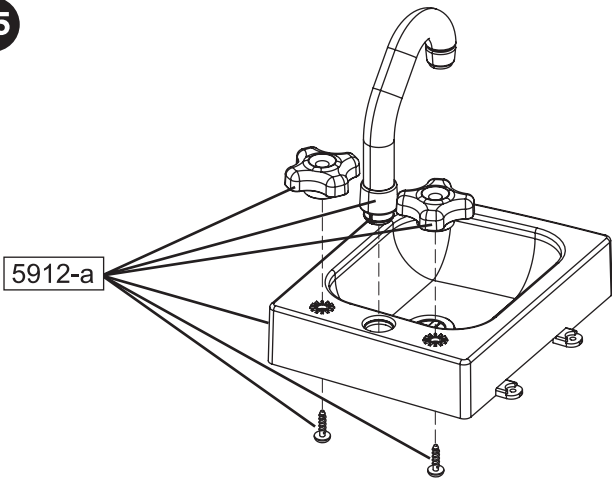

Important: Use a hand held screw driver and DO NOT over tighten.

Important : Utiliser un tournevis manuel et ne PAS TROP serrer.

Importante: Use un destornillador de mano y no atornille en exceso.

Wichtig: Verwenden Sie einen Schraubenzieher und achten Sie darauf, die Schrauben NICHT zu fest anzuziehen.

Importante: usare un cacciavite a mano e NON serrare troppo.

1 x 5912-a



36

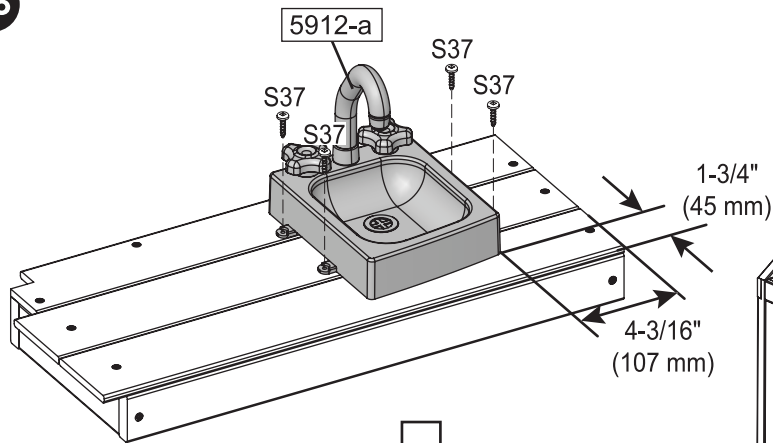

1 x 5912-b

6 x S37

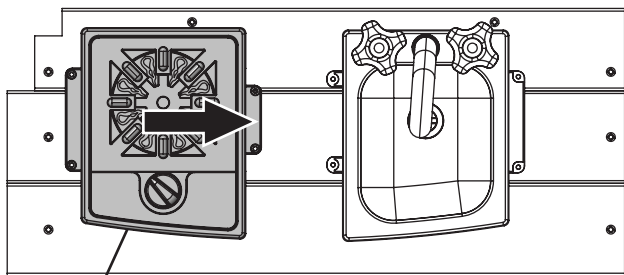
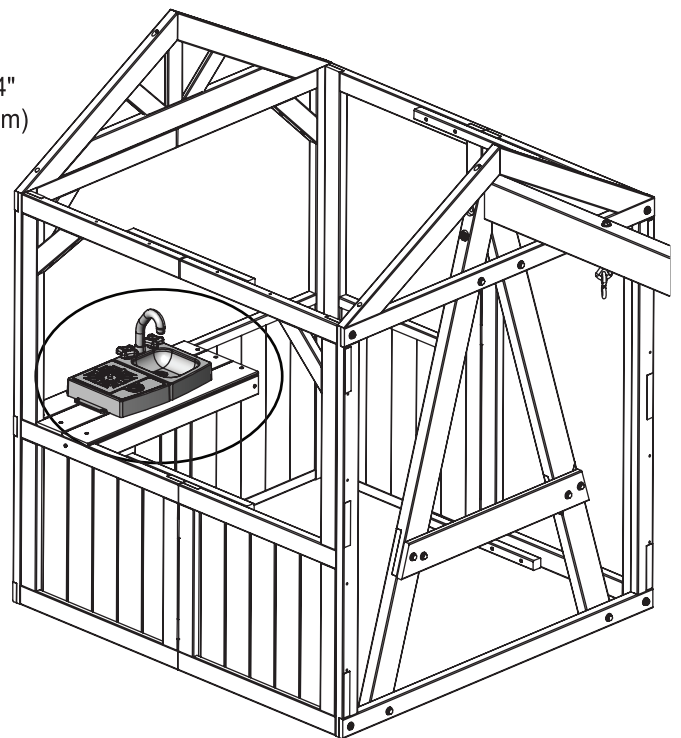

5912-b

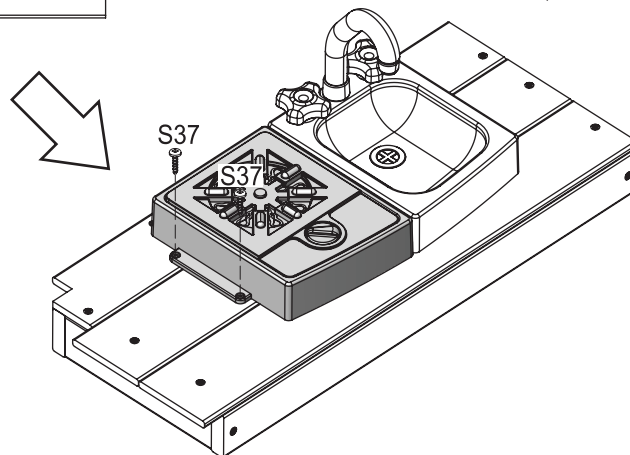

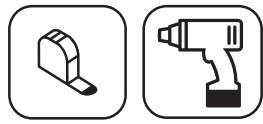

- 1 x 4463-STGY
 - 1 x 4451-STGY
 - 1 x 4452-STGY
 - 1 x 4450-RD
-
- 2 x S37

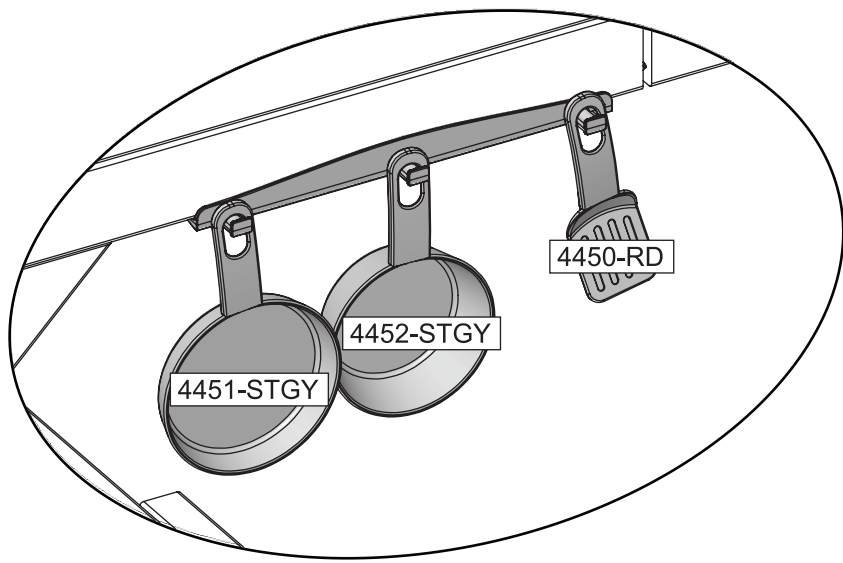
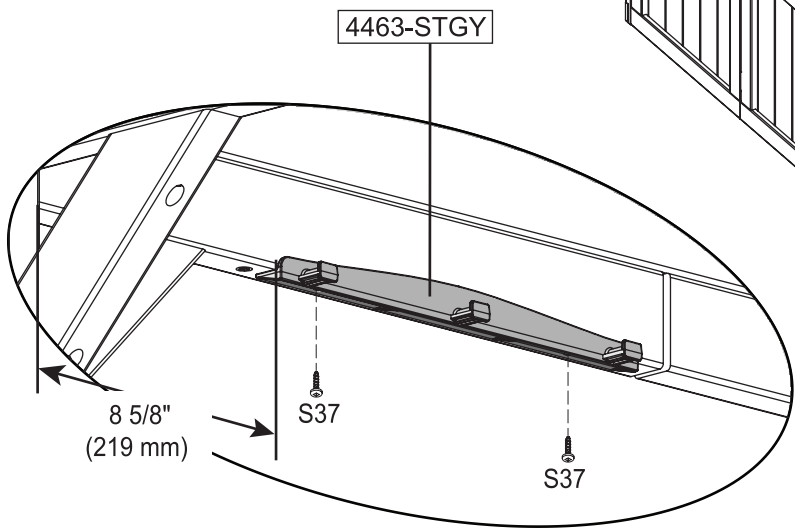
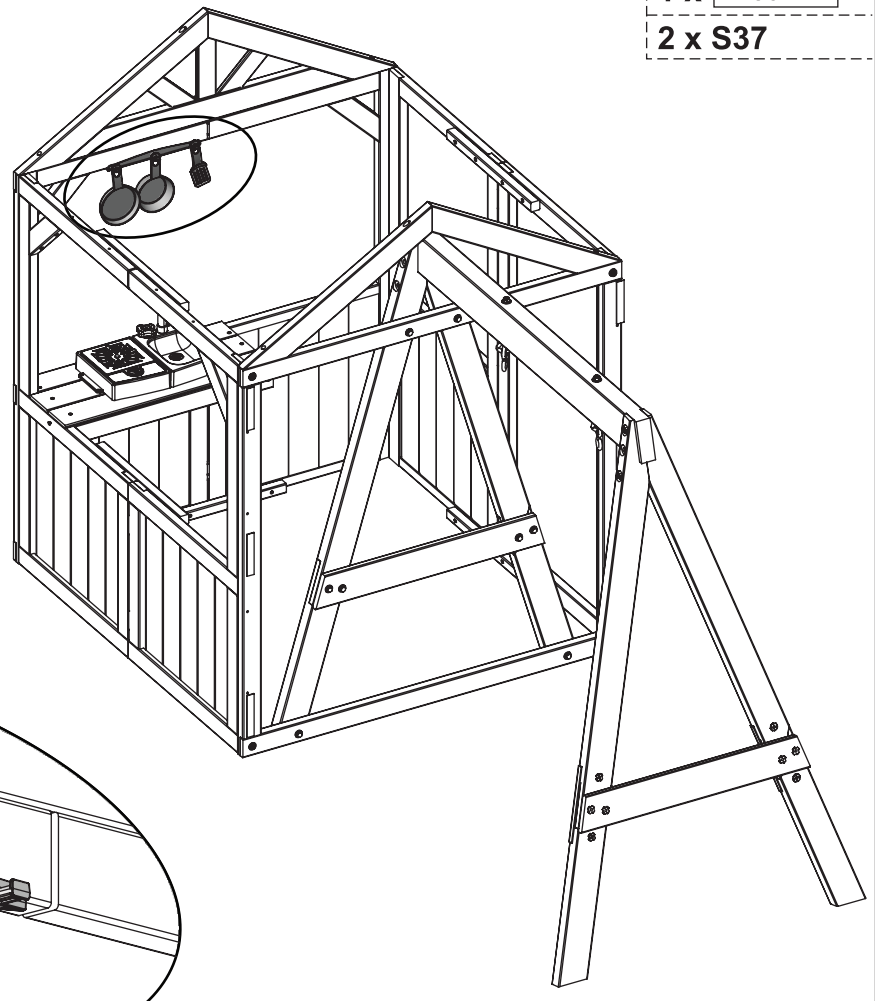

38



1 x 27

1 x 4459-b

2 x S37

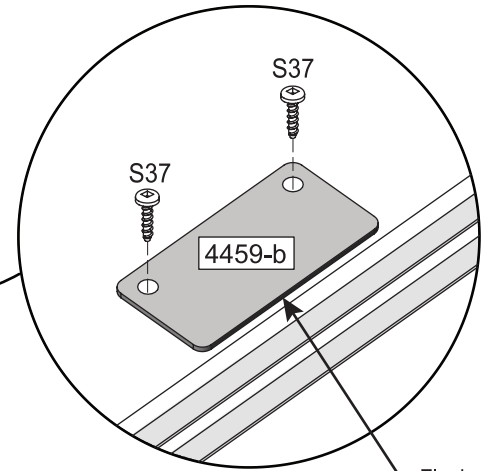
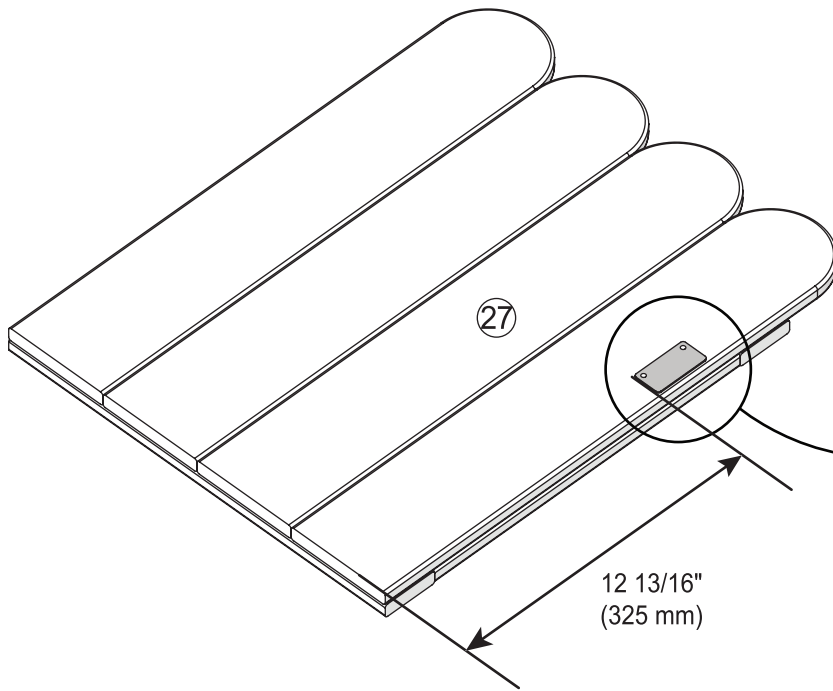

Flush
Aligné
A ras
Bündig
A filo

39



2 x 4465-BK

6 x S37

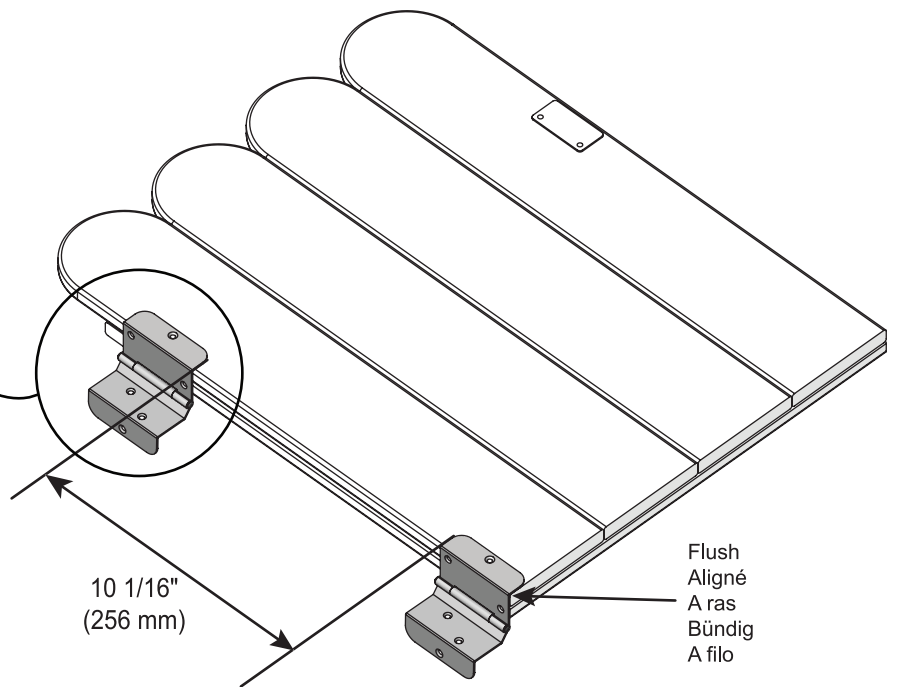
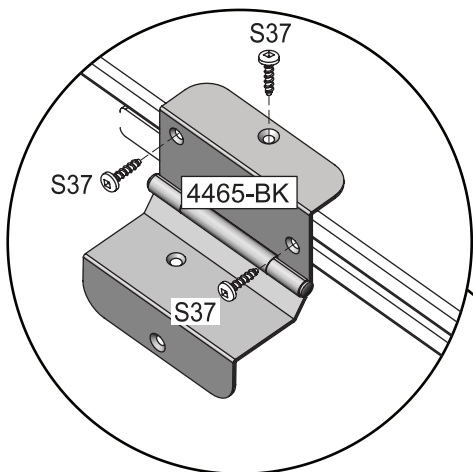

Flush
Aligné
A ras
Bündig
A filo

40



1 x 4458-BK

2 x S37

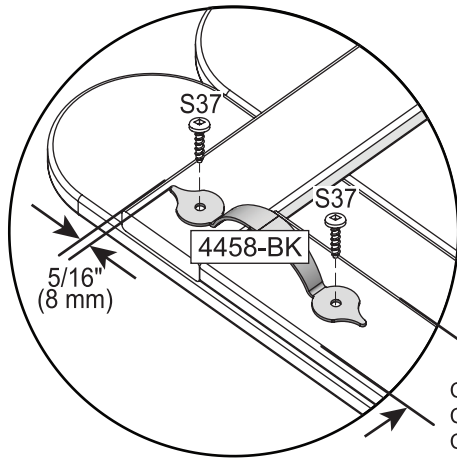

Centered
Centré
Centrado
Zentriert
Centrato

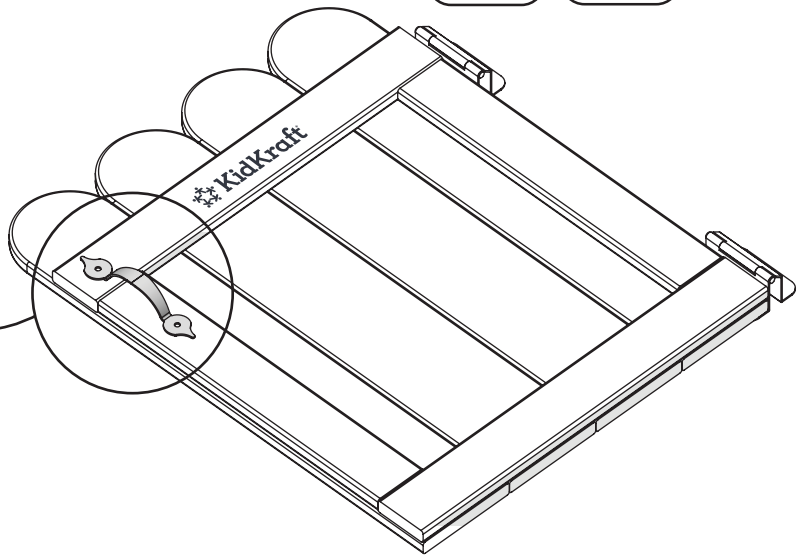

41



6 x S37

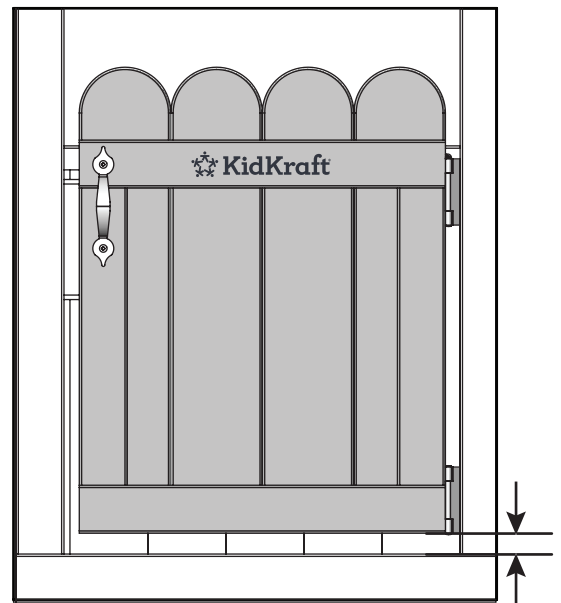
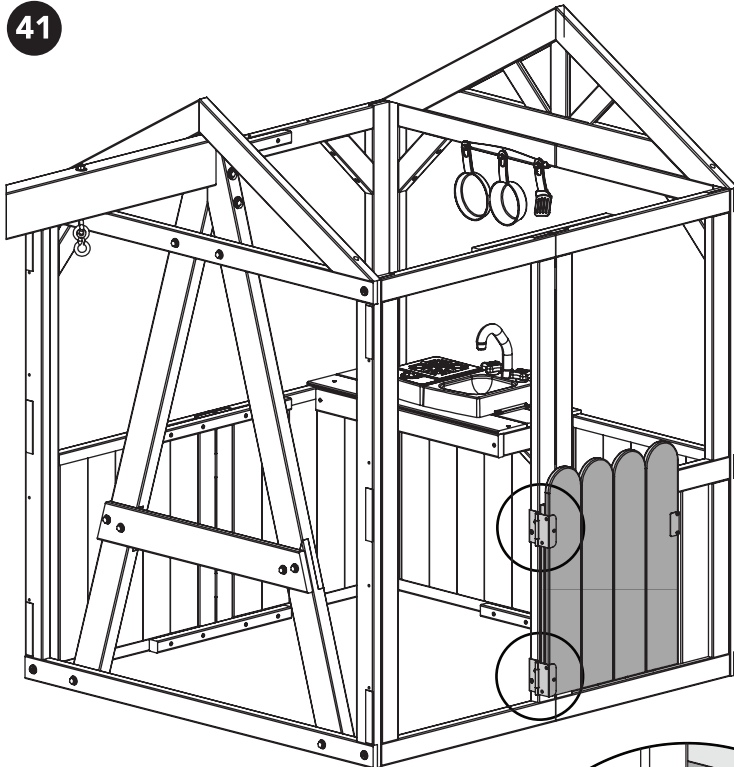

Door closed / Outside View
Porte fermée / Vue extérieure
Puerta cerrada / Vista exterior
Tür geschlossen / Außenansicht
Porta chiusa / Vista dall'esterno

7/8"
(22 mm)

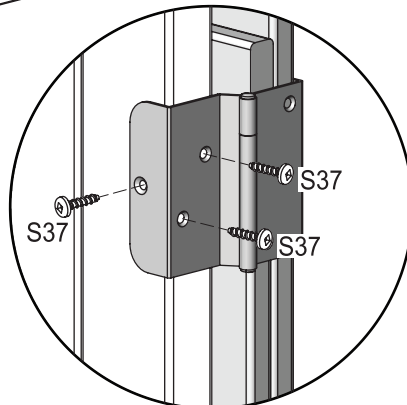

Rotated View
Vue tournée
Vista girada
Gedrehte Ansicht
Nuovo orientamento

42

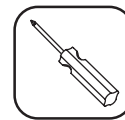

1 x 28
1 x 4459-a
2 x S38

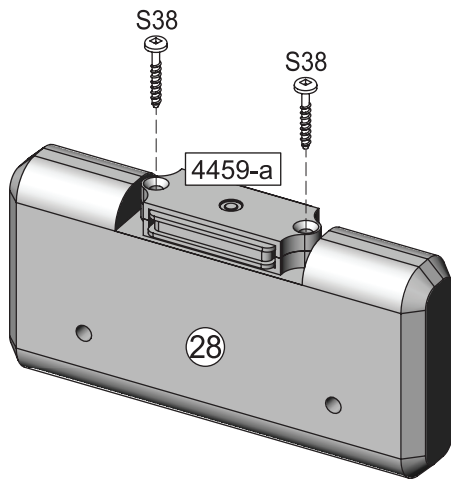

Important: Use a hand held screw driver and DO NOT over tighten.

Important : Utiliser un tournevis manuel et ne PAS TROP serrer.

Importante: Use un destornillador de mano y no atornille en exceso.

Wichtig: Verwenden Sie einen Schraubenzieher und achten Sie darauf, die Schrauben NICHT zu fest anzuziehen.

Importante: usare un cacciavite a mano e NON serrare troppo.



43

Note: Close door and vertically center 4459-a to 4459-b to assemble.
Remarque : Fermer la porte et centrer verticalement 4459-a sur 4459-b pour réaliser l'assemblage.
Nota: Cierre la puerta y centre verticalmente 4459-a con 4459-b para el montaje.
Hinweis: Zum Zusammenbauen die Tür schließen und 4459-a vertikal an 4459-b zentrieren.
Nota: chiudere la porta e centrare verticalmente da 4459-a a 4459-b per assemblare.



2 x S15

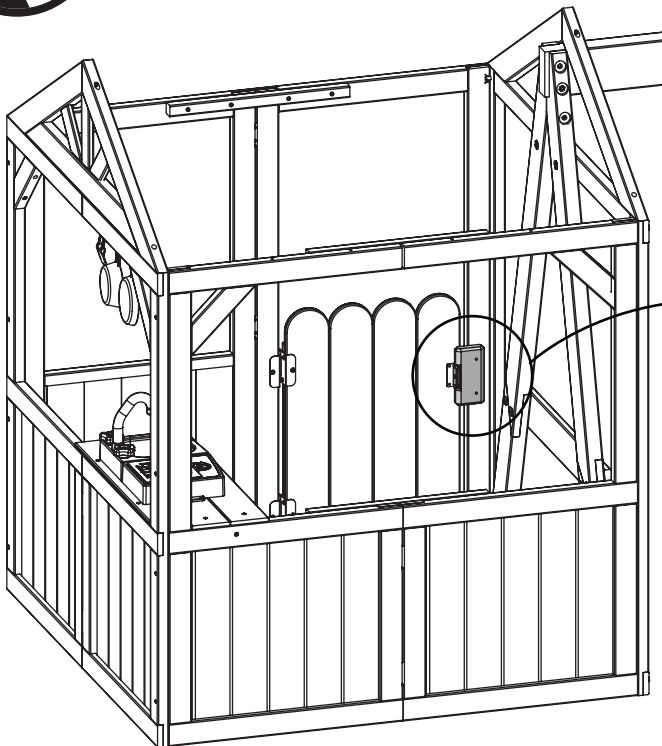

4459-b

4459-a

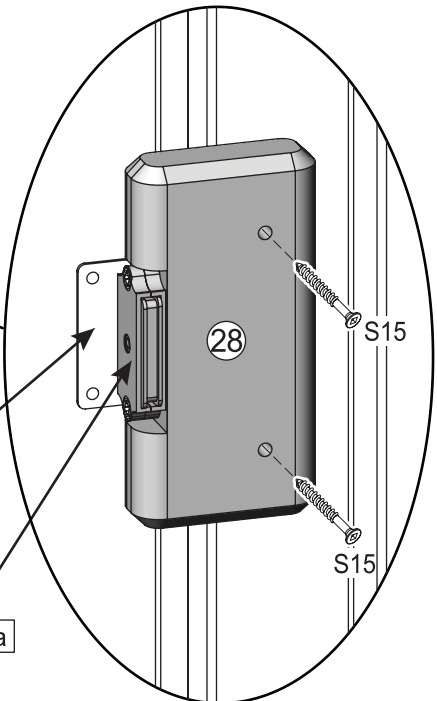

S15

S15

44



- 1 x 7190-MNRV-a
- 1 x 7190-MNRV-b

- 3 x LNJ
- 6 x FW0
- 3 x PBJ

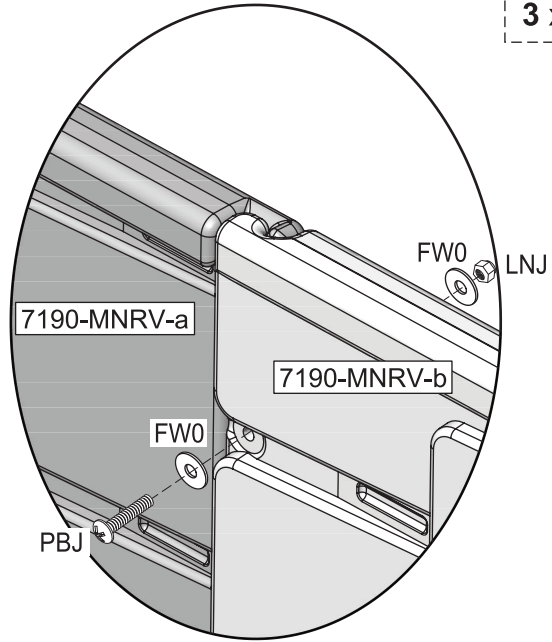
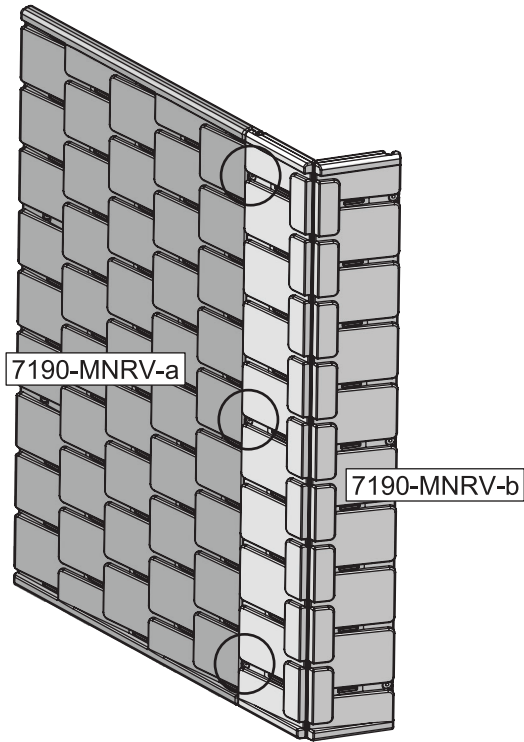

45



- 1 x 7190-MNRV-a

- 3 x LNJ
- 6 x FW0
- 3 x PBJ

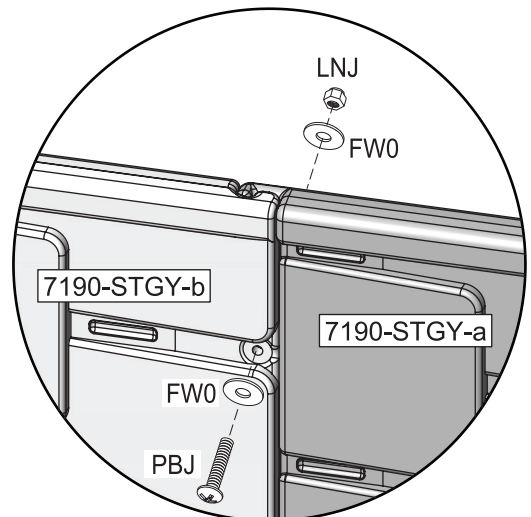
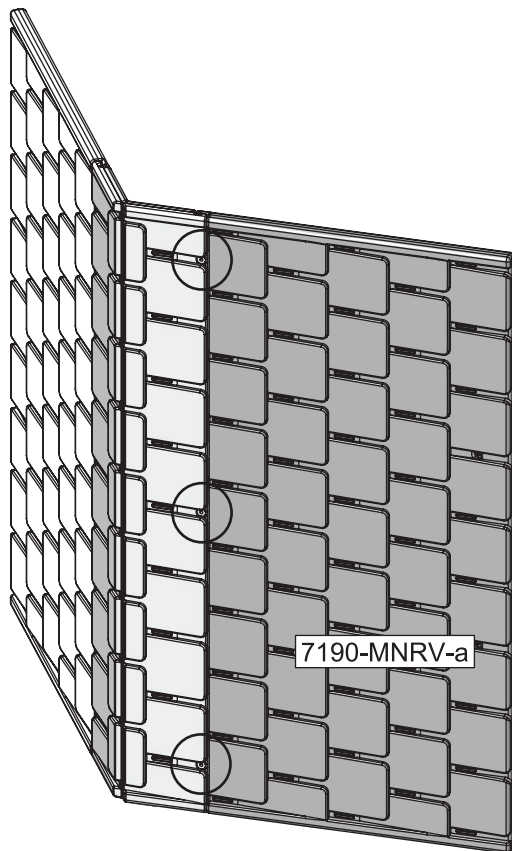

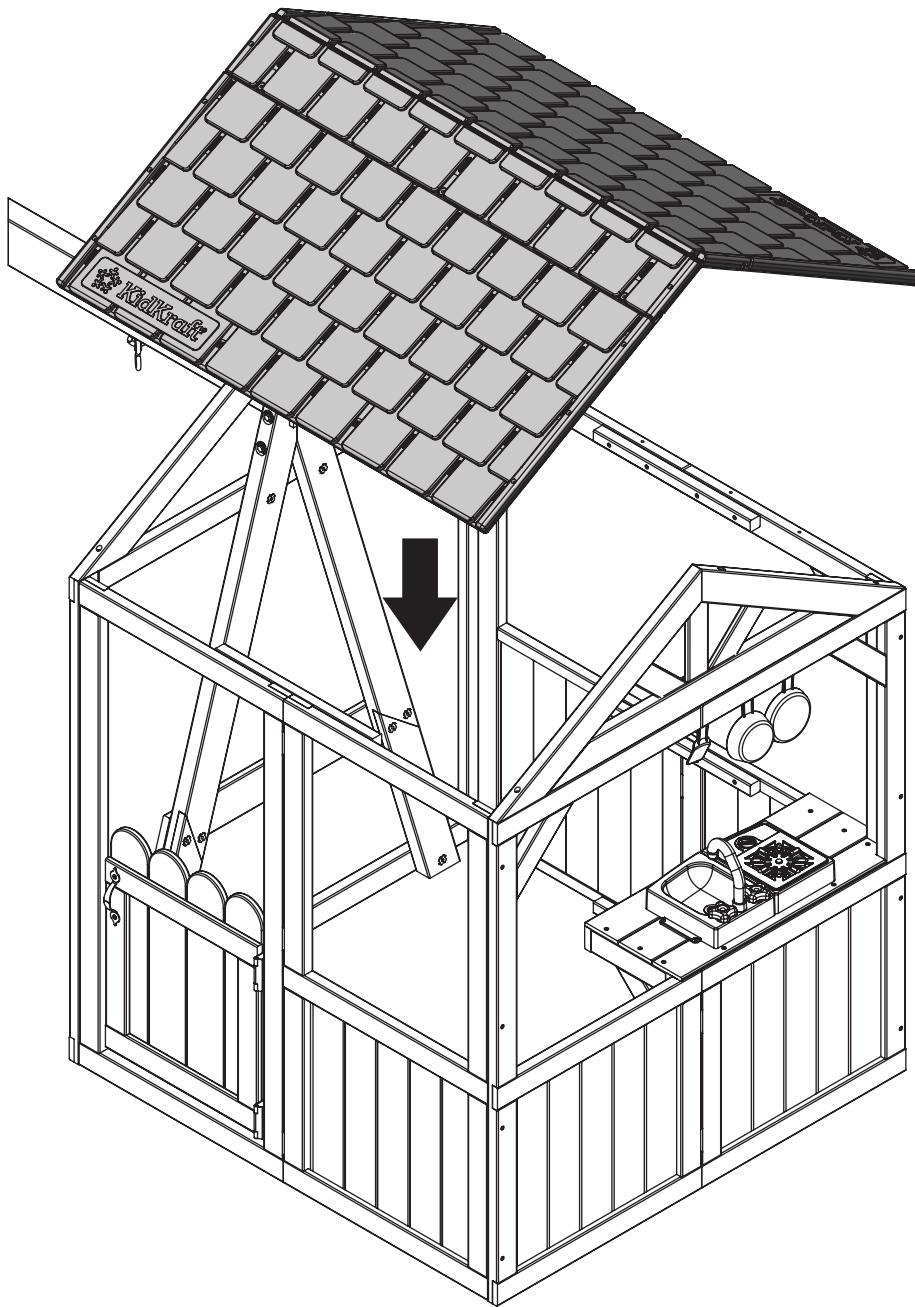

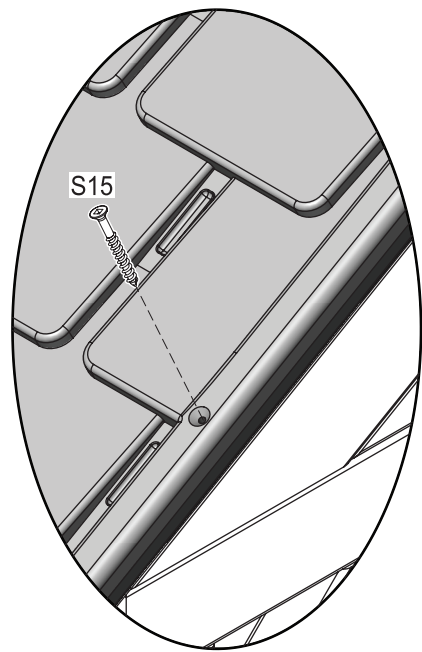
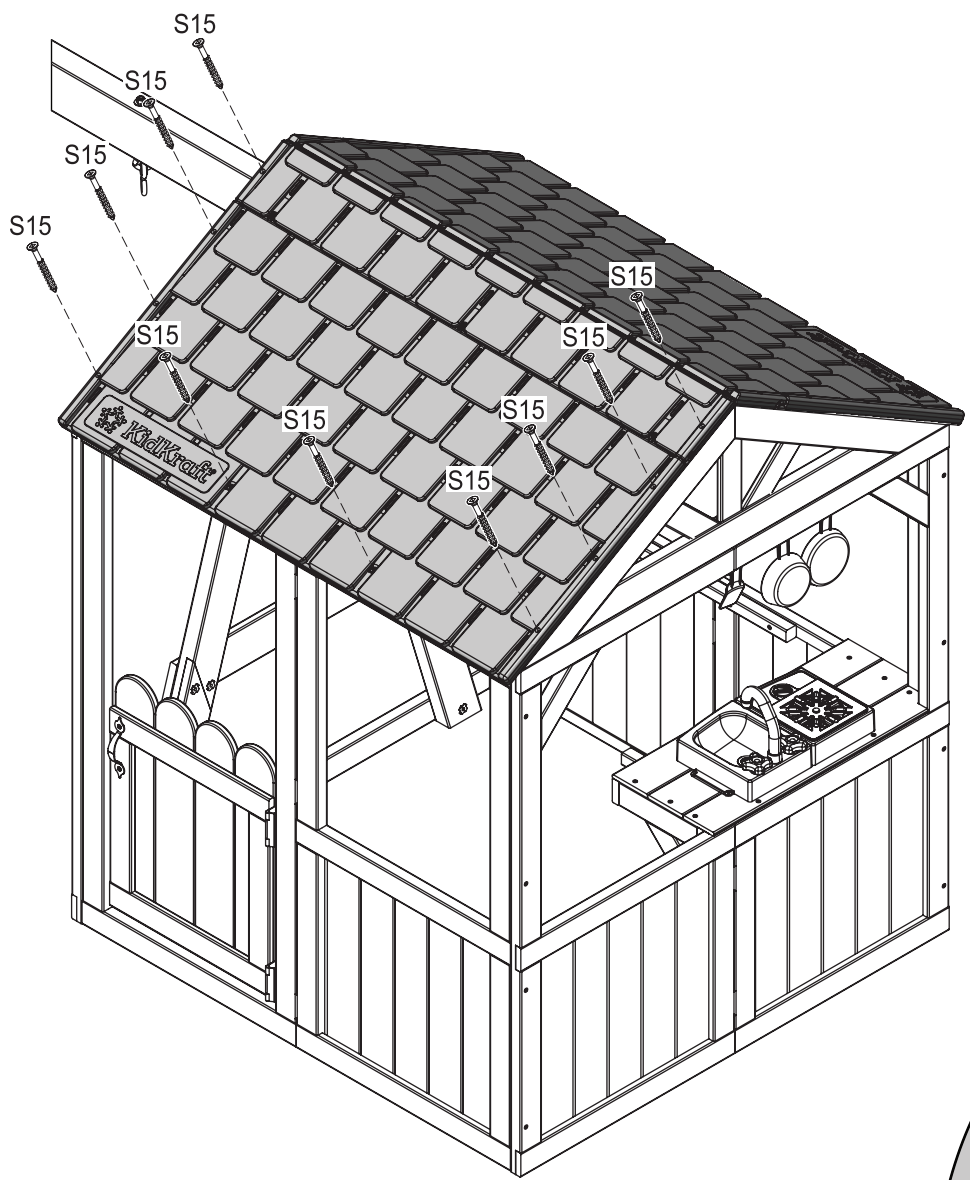

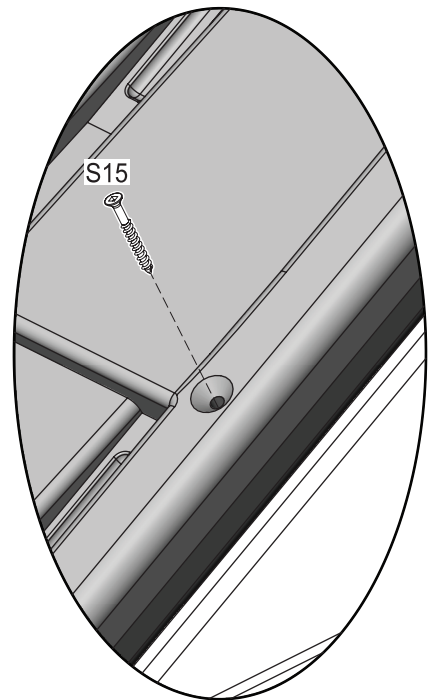
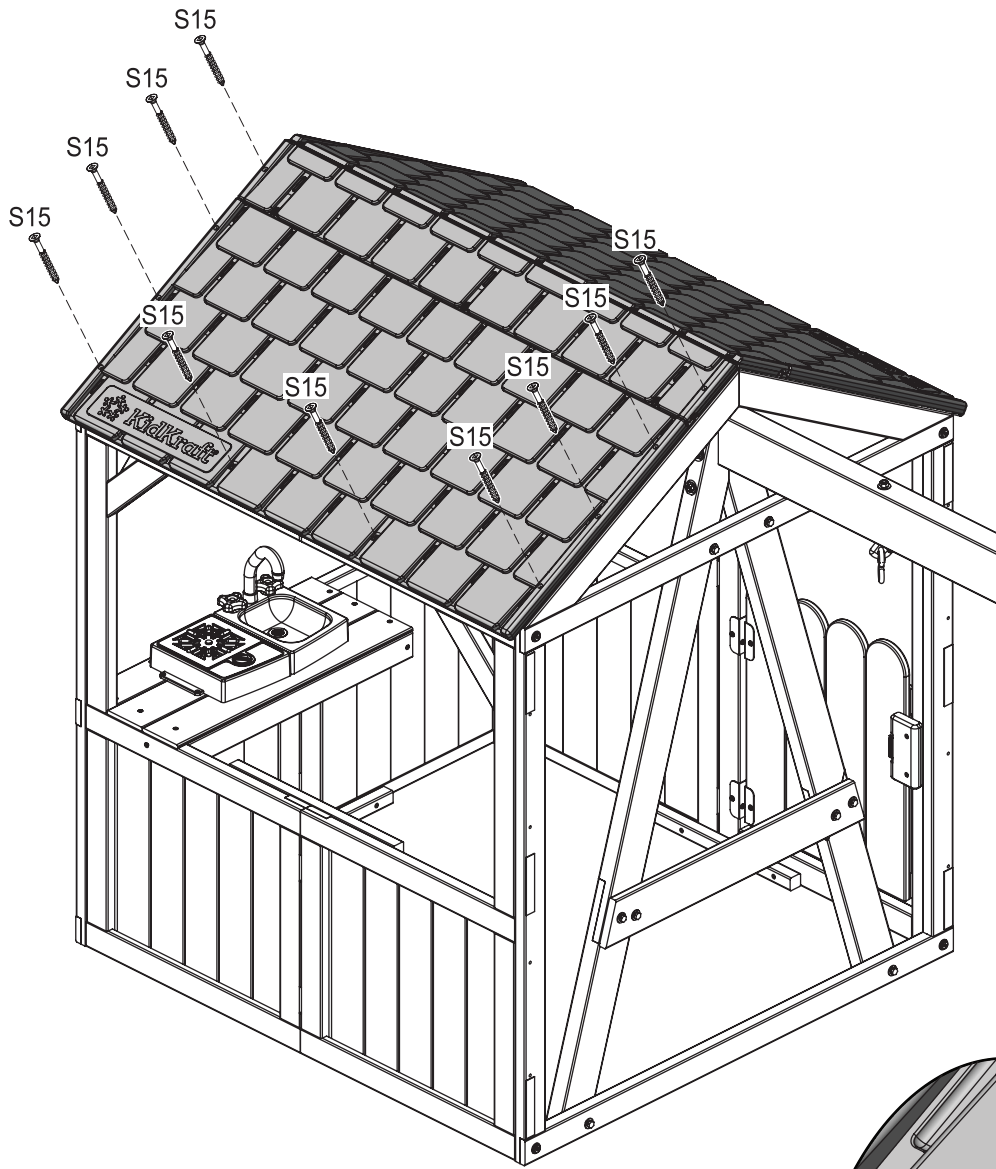

49

SEE COVER PAGE FOR SAFETY CLEARANCE

CONSULTEZ LA PAGE DE COUVERTURE POUR LES DISTANCES DE SÉCURITÉ

VÉASE LA CUBIERTA FRONTAL PARA CONSULTAR LA DISTANCIA DE SEGURIDAD

DER SICHERHEITSABSTAND IST AUF DEM DECKBLATT ANGEGBEN

VEDERE LA COPERTINA PER LO SPAZIO DI SICUREZZA



4 x 9290318

4 x S6

MOVE FORT TO FINAL LOCATION PRIOR TO STAKING
FINAL LOCATION MUST BE LEVEL GROUND

DÉPLACEZ LE FORT VERS SON EMPLACEMENT FINAL
AVANT D'INSTALLER LES PIQUETS L'EMPLACEMENT
FINAL DOIT ÊTRE SUR UNE SURFACE PLANE

MUEVA EL FUERTE A LA UBICACIÓN DEFINITIVA ANTES
DE EMPEZAR A APILAR LA UBICACIÓN DEFINITIVA
DEBE ESTAR SOBRE SUELO NIVELADO

BRINGEN SIE DAS SPIELHAUS ZUNÄCHST AN SEINE
ENDGÜLTIGE POSITION. DER UNTERGRUND AN DIESER
STELLE MUSS EBEN SEIN.

POSIZIONARE IL FORTINO NELLA POSIZIONE FINALE
PRIMA DI PICCHETTARE LA POSIZIONE FINALE DEVE
ESSERE UNA SUPERFICIE PIANA

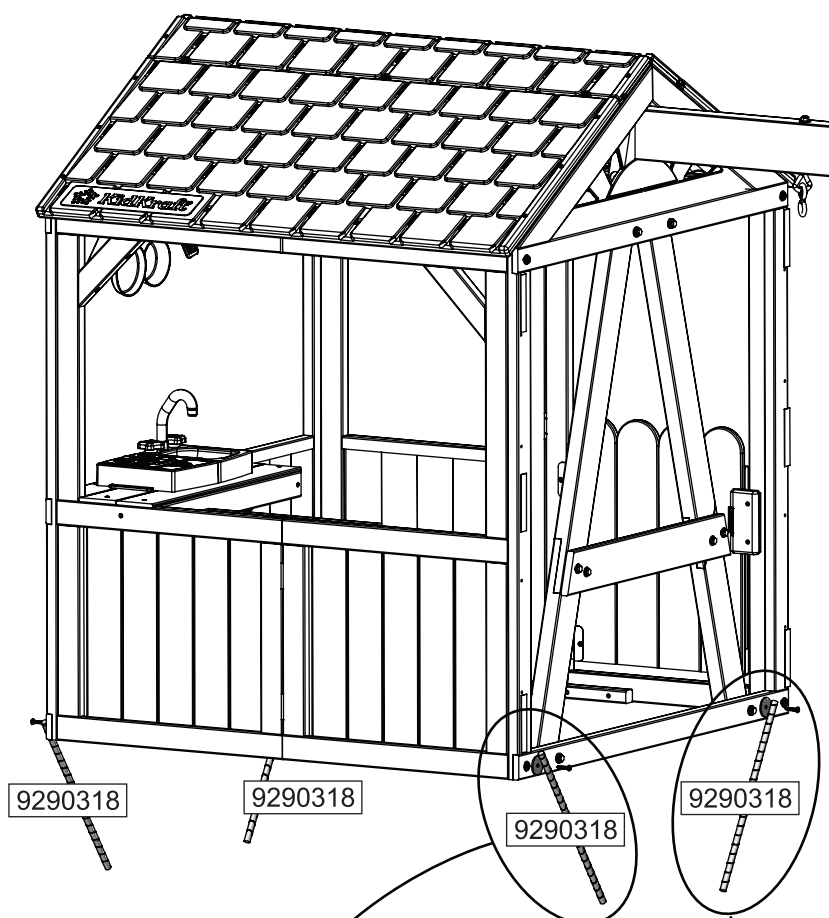

Warning! To prevent tipping and avoid potential injury, stakes must be driven 13" (33 cm) into ground. Digging or driving stakes can be dangerous if you do not check first for under-ground wiring, cables or gas lines.

Attention ! Afin d'éviter le basculement et les blessures potentielles, les piquets doivent être enfoncés 13" (33 cm) dans le sol. Creuser ou enfoncer des piquets peut être dangereux si vous ne vérifiez pas d'abord le câblage souterrain, les lignes ou les conduites de gaz.

¡Advertencia! A fin de evitar vuelcos y posibles lesiones, las estacas deben clavarse a una profundidad de 13" (33 cm). Clavar las estacas o introducir las en el suelo puede ser peligroso si no se comprueba antes la ausencia de conductores, cables o tuberías de gas subterráneos.

Warnung! Um mögliche Verletzungen durch ein Umstürzen des Spielhauses zu verhindern, müssen die Bodenanker 33 cm tief in den Boden getrieben werden. Bevor Sie mit dem Graben der Löcher für die Bodenanker oder dem Einschlagen der Bodenanker beginnen, prüfen Sie zunächst, ob unterirdische Stromleitungen, Kabel oder Gasleitungen unter dem Spielhaus durchführen.

Avvertenza. Per prevenire potenziali incidenti, inserire i paletti per 33 cm nel terreno. Scavare o posizionare i paletti può essere un'attività pericolosa se non si controlla l'eventuale presenza di cablaggi elettrici, cavi o linee del gas nel terreno.

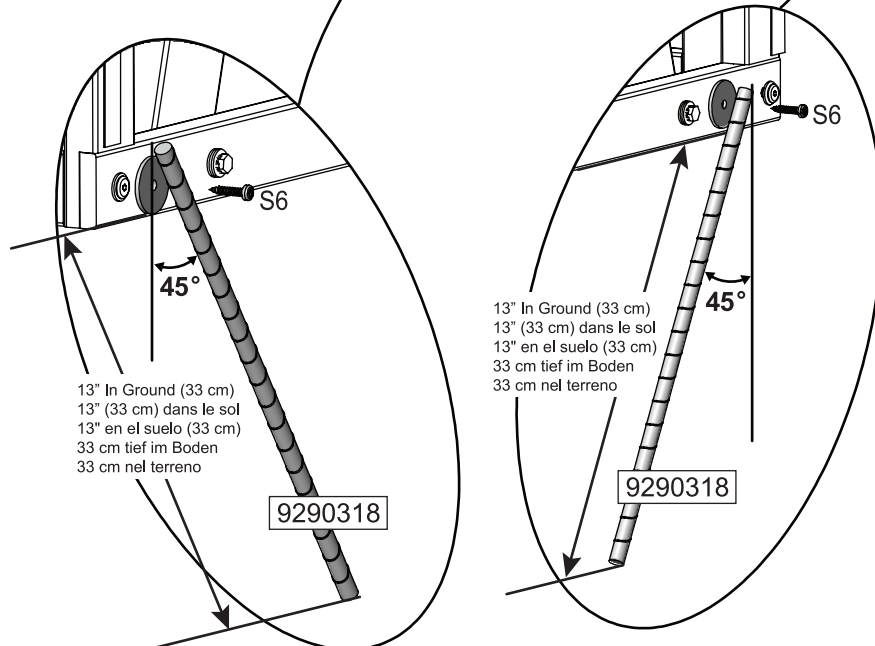

europcustomerservice@kidkraft.com

+31 20 305 8620

M-F from 09:00 to 17:30 (GMT+1)

parts.kidkraft.eu





2 x 9290318

2 x S6

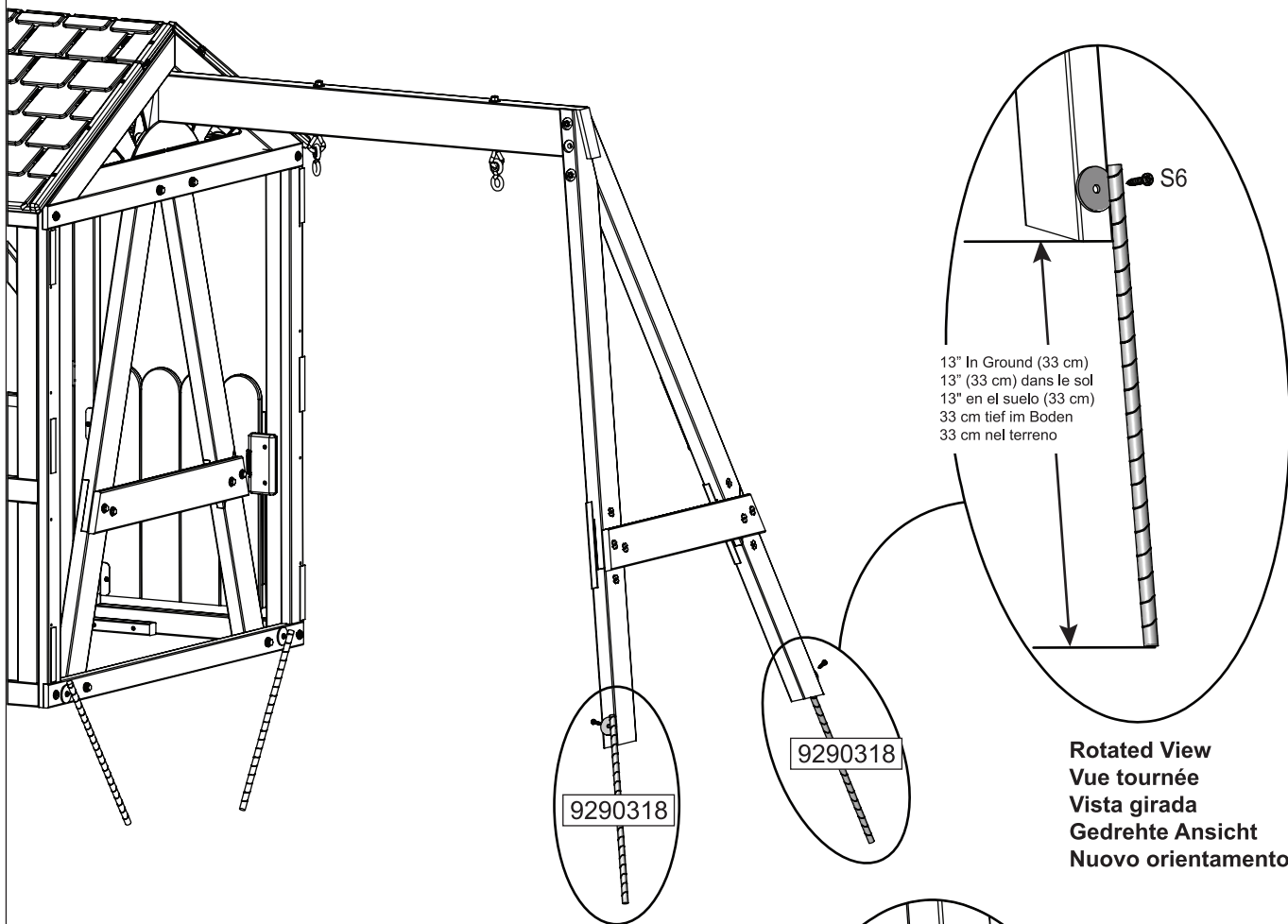

13" In Ground (33 cm)
13" (33 cm) dans le sol
13" en el suelo (33 cm)
33 cm tief im Boden
33 cm nel terreno

Rotated View
Vue tournée
Vista girada
Gedrehte Ansicht
Nuovo orientamento



Warning! To prevent tipping and avoid potential injury, stakes must be driven 13" (33 cm) into ground. Digging or driving stakes can be dangerous if you do not check first for under-ground wiring, cables or gas lines.

Attention ! Afin d'éviter le basculement et les blessures potentielles, les piquets doivent être enfoncés 13" (33 cm) dans le sol. Creuser ou enfoncer des piquets peut être dangereux si vous ne vérifiez pas d'abord le câblage souterrain, les lignes ou les conduites de gaz.

¡Advertencia! A fin de evitar vuelcos y posibles lesiones, las estacas deben clavarse a una profundidad de 13" (33 cm). Clavar las estacas o introducir las en el suelo puede ser peligroso si no se comprueba antes la ausencia de conductores, cables o tuberías de gas subterráneos.

Warnung! Um mögliche Verletzungen durch ein Umstürzen des Spielhauses zu verhindern, müssen die Bodenanker 33 cm tief in den Boden getrieben werden. Bevor Sie mit dem Graben der Löcher für die Bodenanker oder dem Einschlagen der Bodenanker beginnen, prüfen Sie zunächst, ob unterirdische Stromleitungen, Kabel oder Gasleitungen unter dem Spielhaus durchzuführen.

Avvertenza. Per prevenire potenziali incidenti, inserire i paletti per 33 cm nel terreno. Scavare o posizionare i paletti può essere un'attività pericolosa se non si controlla l'eventuale presenza di cablaggi elettrici, cavi o linee del gas nel terreno.

S6

13" In Ground (33 cm)
13" (33 cm) dans le sol
13" en el suelo (33 cm)
33 cm tief im Boden
33 cm nel terreno

9290318



KidKraft
MADE FOR MAKE BELIEVE™

parts.kidkraft.com

customerservice@kidkraft.com
1.800.933.0771
972.385.0100



- 1 x 29
- 8 x S37
- 8 x FW0

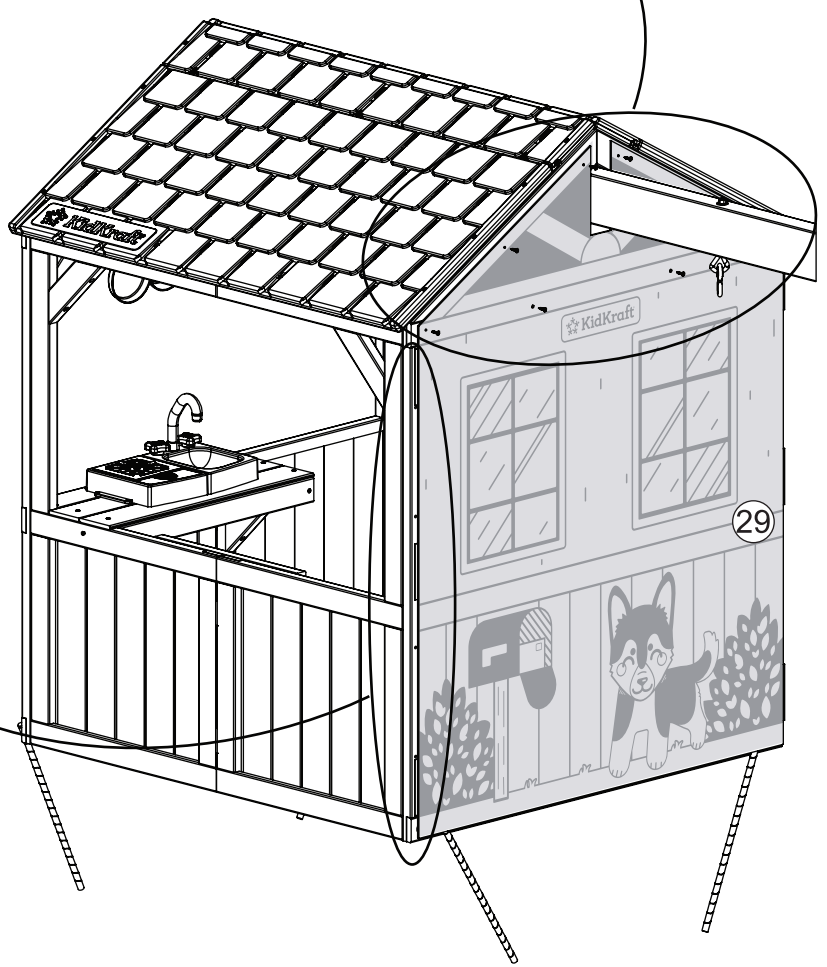
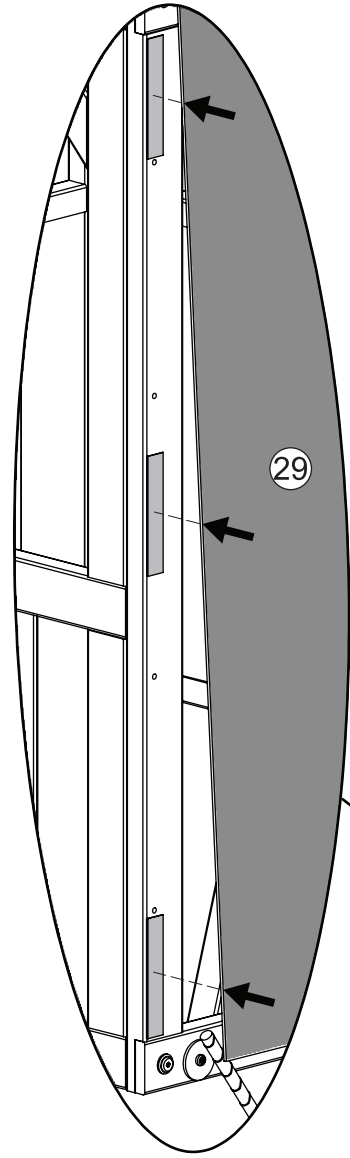
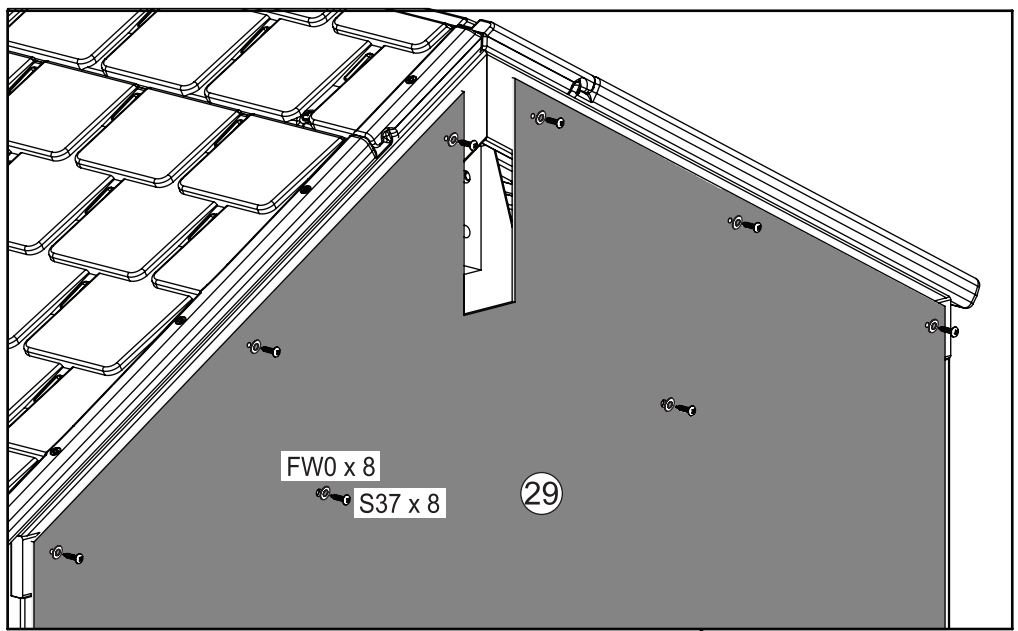

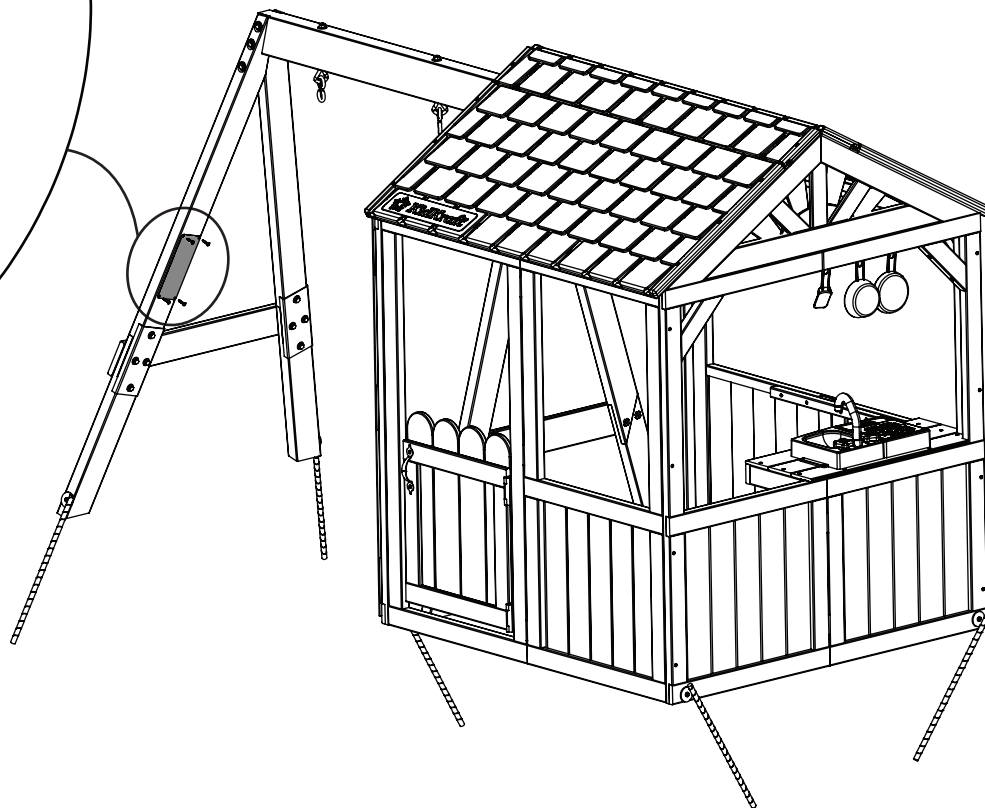
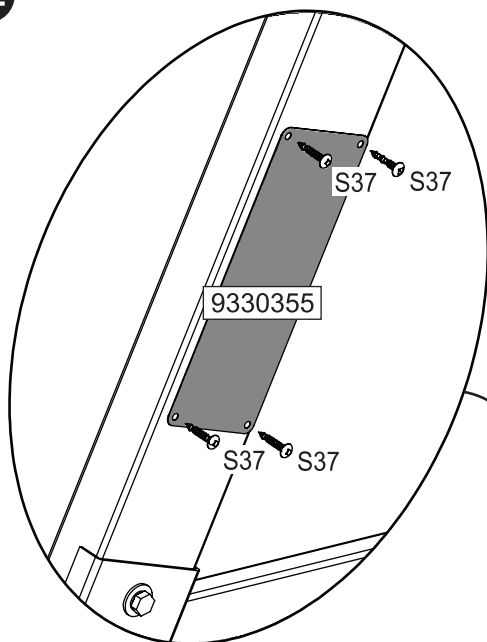

ATTACH THIS WARNING & I.D. PLAQUE TO THIS LOCATION ON YOUR PLAY EQUIPMENT!

This provides warnings concerning safety and important contact information. A Tracking Number is provided to allow you to get critical information or order replacement parts for this specific model.

PLACEZ CET AVERTISSEMENT ET CETTE PLAQUE D'IDENTIFICATION ICI SUR VOTRE AIRE DE JEUX !

Il s'agit d'avertissements concernant la sécurité et les contacts importants. Un numéro de suivi est fourni pour vous permettre d'obtenir des informations importantes ou de commander des pièces de rechange pour ce modèle spécifique.

¡FIJE ESTA PLACA DE ADVERTENCIA E IDENTIFICACIÓN EN LA UBICACIÓN QUE SE INDICA EN SU CENTRO DE JUEGOS!

Proporciona importantes advertencias sobre seguridad y datos de contacto. Se proporciona un número de seguimiento que le permitirá recibir información muy importante o encargar recambios para este modelo específico.

BRINGEN SIE DIESE ID- UND WARNPLAKETTE AN DIESER STELLE AM SPIELHAUS AN!

Darauf befinden sich wichtige Sicherheitshinweise und Kontaktinformationen. Mit der Nachverfolgungsnummer können Sie zudem wichtige Informationen einsehen oder Ersatzteile für dieses Modell bestellen.

FISSARE QUESTA TARGHETTA IDENTIFICATIVA E DI AVVERTENZA SULL'ATTREZZATURA DA GIOCO!

Fornisce avvertenze riguardanti la sicurezza e importanti informazioni di contatto. È presente un numero di tracciabilità che offre informazioni importanti o consente di ordinare i pezzi di ricambio per questo modello specifico.

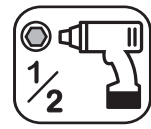

- 2 x 3503073
- 1 x 9720072

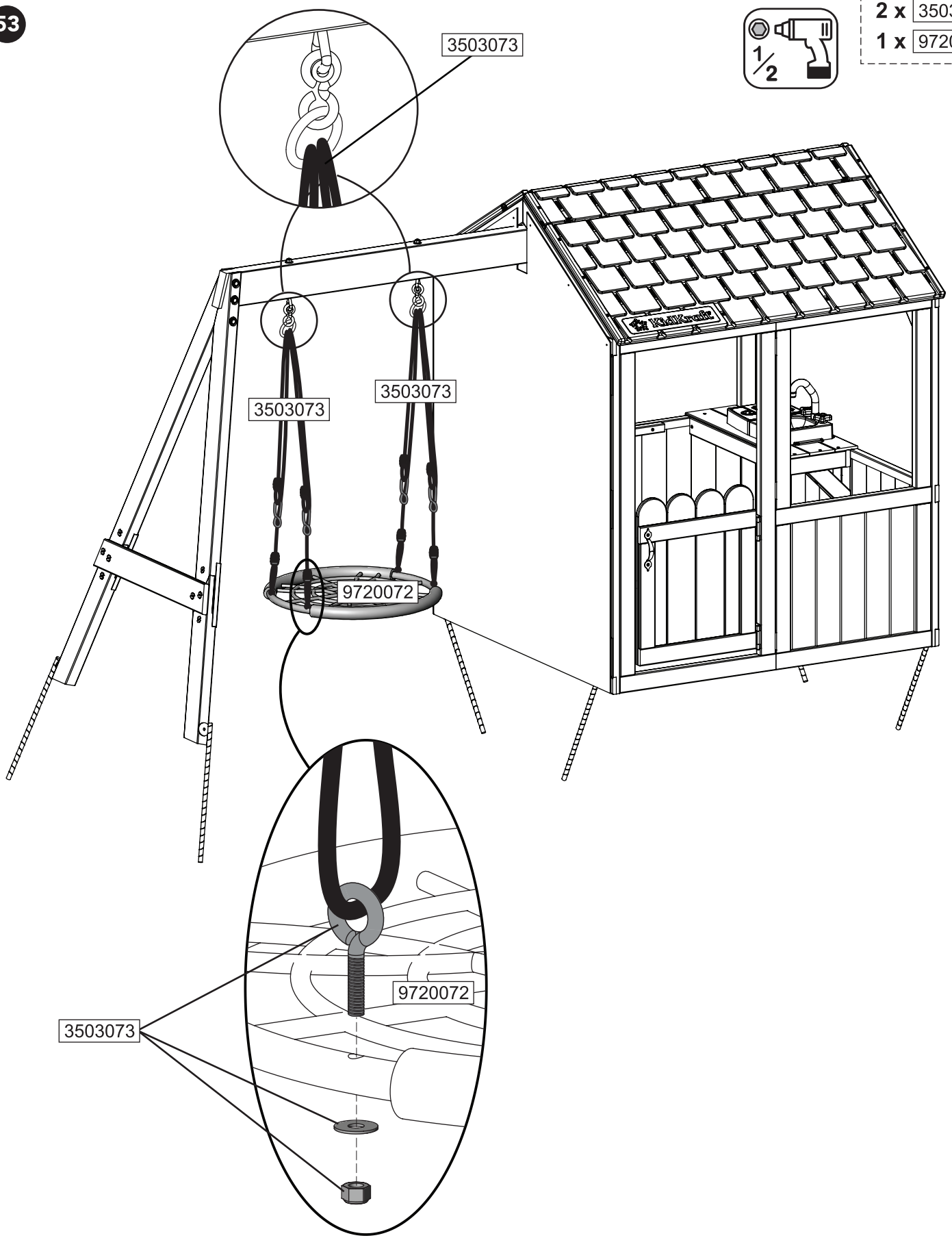

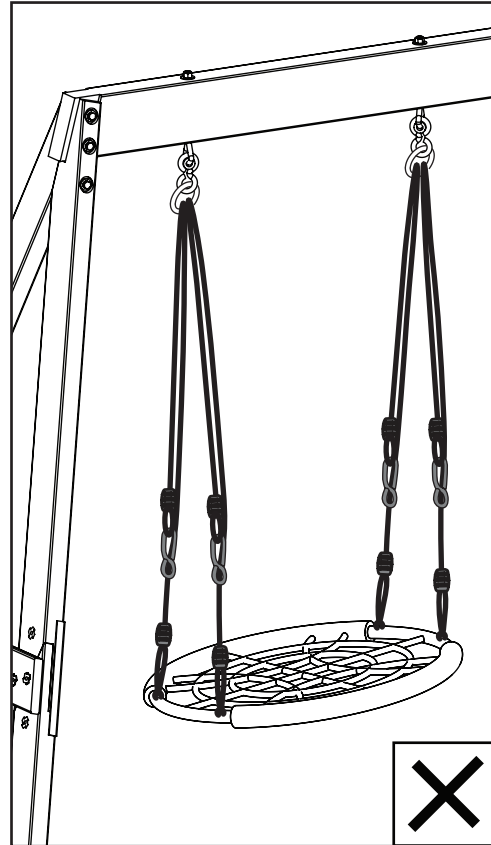
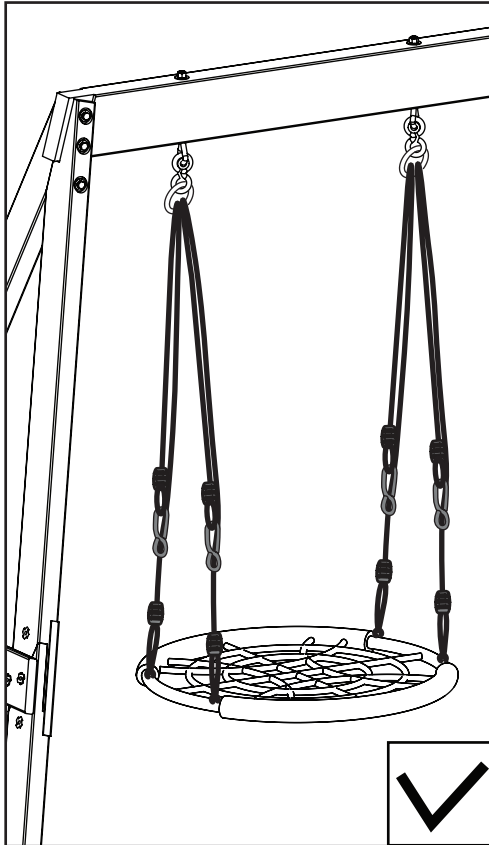

Adjust swing ropes as needed to ensure that swing is level.

Ajuster les cordes afin que la balançoire soit à niveau.

Ajuste las cuerdas del columpio según sea necesario hasta asegurarse de que el columpio esté nivelado.

Stellen Sie die Schaukelseile nach Bedarf ein, um sicherzustellen, dass die Schaukel eben ist.

Regolare le corde dell'oscillazione secondo necessità per garantire che l'oscillazione sia livellata.

