

**STEELCRAFT FORTIS FRONT BUMPER
2023-24 FORD SUPER DUTY**

PARTS LIST:

1	Fortis Front Bumper	14	12mm x 50mm Hex Bolts
1	Driver/left Side Frame Bracket	32	12mm x 32mm x 3mm Flat Washers
1	Passenger/right Side Frame Bracket	18	12mm Hex Nuts
1	Driver/left Side Support Bracket	18	12mm Lock Washers
1	Passenger/right Side Support Bracket	4	12mm Bolt Plates
1	Driver/left Side LED light L-bracket	4	8mm Hex Nuts
1	Passenger/right Side LED light L-bracket	6	8mm Lock Washers
1	Adaptive Cruise Control (ACC) Plastic Cover	2	8mm x 30mm Hex Bolts
1	ACC Sensor Relocation Bracket	2	8mm x 25mm Hex Bolts
1	ACC Cover Bracket	2	8mm x 16mm Hex Bolts
2	Plastic Plugs for license plate mount	10	8mm x 24mm x 2mm Flat Washers
2	Parking Sensor Wire Extenders	7	6mm Lock Washers
4	Sensor Retaining Caps	7	6mm Hex Nuts
4	15.5mm x 25mm Foam Washer Sensor Seals	3	6mm x 30mm Hex Bolts
4	20mm x 10mm Foam Sensor Spacers	4	6mm x 20mm Button Head Bolts
1	Sensor Cover Kit	10	6mm x 18mm x 1.6mm Flat Washers
4	Plastic Sensor Hole Plugs	8	4mm Self Tapping Screws
1	Adhesive Backed Foam Pad	1	4mm Allen Wrench

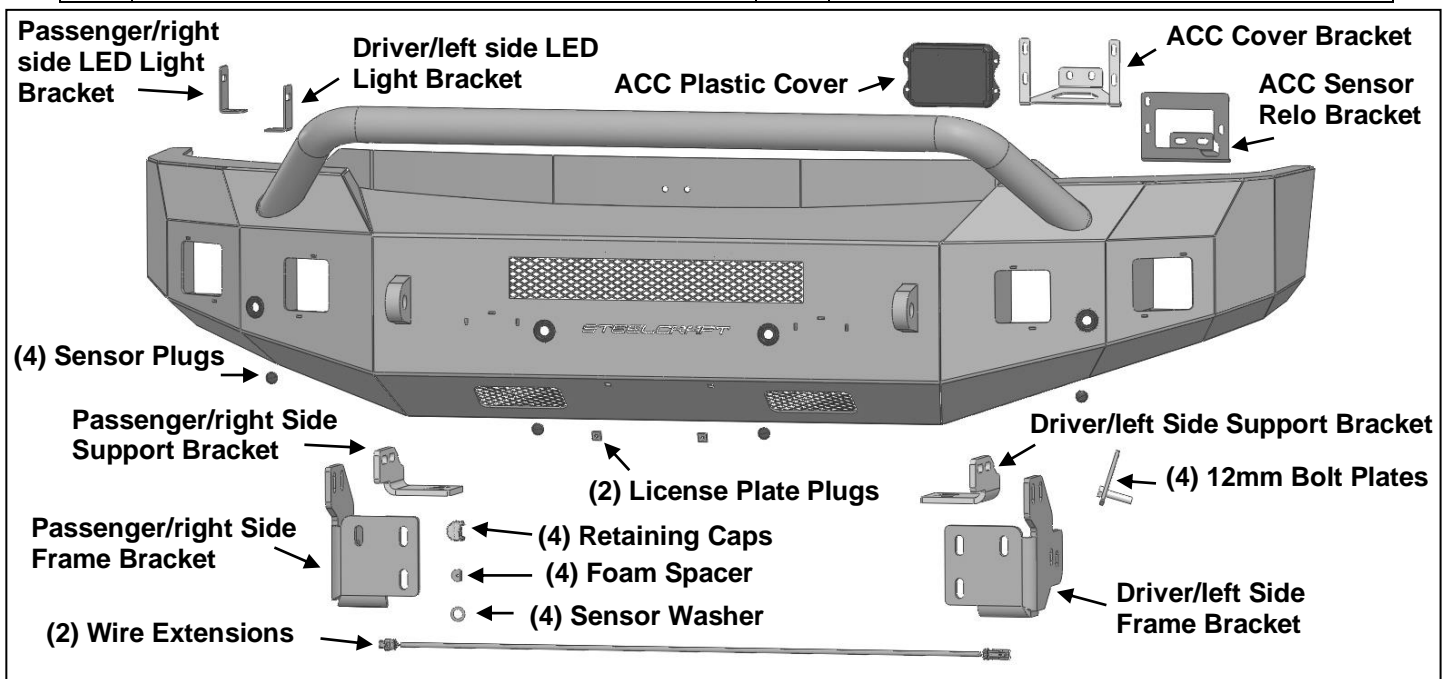

PROCEDURE:

SOME PARTS ARE SMALL AND WILL BE HIDDEN IN WRAPPINGS. REMOVE CONTENTS FROM PACKAGING. VERIFY ALL PARTS ARE PRESENT. READ INSTRUCTIONS CAREFULLY BEFORE STARTING INSTALLATION. BUMPER IS HEAVY, ASSISTANCE IS HIGHLY RECOMMENDED TO AVOID POSSIBLE INJURY OR DAMAGE TO THE VEHICLE.

1. Remove the license plate. Unplug all wiring harnesses connecting bumper to vehicle (**Figure 1**).
2. Remove the bumper supports attaching the outer ends of the bumper to the outside of the frame, (**Figure 2**). Remove the plastic covers from the tow hooks to uncover the bumper bolts, (**Figure 3**).
3. Place blocks or jack stands under the front bumper to support it during mounting bolt removal. Once the bumper has been safely supported, remove the (8) factory bumper bolts, (**Figure 4**). If bolts are

**STEELCRAFT FORTIS FRONT BUMPER
2023-24 FORD SUPER DUTY**

blocked by a sensor, see **step 9a** for removal. **WARNING!** Assistance is required to hold the bumper in place during bolt removal to prevent the bumper from falling. Carefully slide the bumper off over the tow hooks. There will be 2 plastic pins that attach the bumper to the grille that need to be pried off (**Figure 5**).

4. Remove the driver/left side tow hook from the end of the frame, (**Figure 6**). Next, remove the (4) factory hex nuts, lower frame extension and double bolt plates from the end of the frame, (**Figure 6**). Repeat this Step to remove the passenger/right side tow hook and lower frame extension. Note: tow hooks will not be re-installed.
5. Select the Driver/left side Frame Bracket and locate the driver/left side frame mounting location, (**Figure 7**). Place the Driver/left Side Frame Bracket against the side of the frame and insert (2) 12mm Bolt Plates in through the frame channel and out the (2) holes of the frame. Attach the Bracket to the Bolt Plates with (2) 12mm Flat Washers, (2) 12mm Lock Washers and (2) 12mm Hex Nuts, (**Figure 7**). Do not tighten hardware at this time.
6. Select the Driver/left Side Support Bracket and place it on top of the frame, against the Frame Bracket. Use the included (4) 12mm Hex Bolts, (8) 12mm Flat Washers, (4) 12mm Lock Washers and (4) 12mm Hex Nuts to attach the Support Bracket to the top of the frame and the Frame Bracket, (**Figure 8**). Do not tighten hardware.
7. Repeat **Steps 5 & 6** for Passenger/right Side Bracket installation.
8. **Optional Center 20-inch LED light bar** (sold separately) - **side mount installation:**
 - a. Select the L/R "L" Brackets. **NOTE:** "L" Brackets are offset for universal fitment for most side mount LED bar style lights. Attach the LED light bar assembly to the "L" Brackets with the included (2) 8mm x 16mm Hex Bolts, (2) 8mm Lock Washers and (2) 8mm Flat Washers, (**Figure 9**). Do not fully tighten hardware at this time. **NOTE:** Some hardware provided with the light can be used. "L" Brackets may require modification for hardware larger than 8mm or use brackets supplied with light if possible.
 - b. Attach the light and brackets to the top of the (2) tabs on the back of the Bumper with the included 8mm x 25mm Hex Bolts, (4) 8mm Flat Washers, (2) 8mm Lock Washers and (2) 8mm Hex Nuts, (**Figure 9**). Adjust light position and tighten hardware.
 - c. Follow light manufacturer's instructions to wire the light to the vehicle's electrical system once Bumper has been fully installed. Note: installation of a light bar can affect airflow to the coolers.
9. Determine if the vehicle is equipped with an adaptive cruise control (ACC) sensor.

Vehicles without ACC, skip to Step 10.

Vehicles equipped with ACC sensor:

- a. Remove the 3 nuts securing the ACC sensor to the front of the OE bumper at the driverside tow hook opening. (**Figure 10**). Unplug the wiring harness and remove the sensor and bracket from the bumper by pulling straight-out.
 - b. Select the provided ACC Sensor Relocation Bracket and attach the sensor with (3) 6mm x 30mm Hex Bolts, (6) 6mm Flat Washers, (3) 6mm Lock Washers and (3) 6mm Hex Nuts, (**Figure 11**). Note: Pay attention that the sensor matches the OE configuration and is straight + level. This may require fine tuning at the end of the install.
 - c. Select the Foam Pad, remove adhesive backing and attach to bottom of ACC Bracket, (**Figure 12**).
 - d. Remove the rubber plugs from the top of the new Fortis Bumper. Select the ACC Cover Bracket and place it in front of the holes, then attach the sensor Relocation assembly from the previous **step** inside the ACC Cover Bracket and through the bumper with (2) 8mm x 30mm Hex Bolts, (4) 8mm Flat Washers, (2) 8mm Lock Washers and (2) 8mm Hex Nuts, (**Figure 13**). Make sure sensor is level.
 - e. Select the ACC Plastic Cover. Insert (4) 6mm x 25mm Button Head Bolts through the (4) holes on the ACC Plastic Cover to each side of the ACC cover bracket. Secure with (4) 6mm Flat Washers, (4) 6mm Lock Washers and (4) 6mm Hex Nuts, (**Figure 14**). Make sure sensor is centered behind Cover.
10. Determine if truck is equipped with front parking sensors.
- For vehicles not equipped with front parking sensors.**
- a. Select the included (4) Plastic Parking Sensor Plugs. From the front of the bumper, push plugs into sensor sleeves, (**Figure 15**).

**STEELCRAFT FORTIS FRONT BUMPER
2023-24 FORD SUPER DUTY**

For vehicles equipped with front parking sensors.

- a. Remove the parking sensors and wiring harness from the factory bumper.
 - b. Select a sensor and remove the OE silicone seal from the end of the sensor. Remove the adhesive backing from the supplied 15.5mm x 25mm x 2mm Foam Washer Sensor Seal. Slide the Foam Seal over front of sensor (**Figure 16**).
 - c. Insert sensor with Seal into sensor mount on back of bumper until it clicks into place, (**Figure 17**).
 - d. Select the included (1) Foam Spacer and peel off the adhesive backing. Place Foam Spacer into (1) Sensor Retainer Cap. Push Sensor Retaining Cap and Foam Spacer onto sensor mount and lock into mounting holes, (**Figure 17**).
 - e. Repeat previous **Steps** to install remaining sensors.
- 11. LED cube light, pedestal mount installation at ends of bumper (sold separately).**
- a. Insert light into opening and up to mounting slots.
 - b. Follow light manufacturer's instructions to attach each light to the slot in the bottom of the light opening. On two light systems, attach flood light to outer slot and spot light to inner slot.
 - c. Follow light manufacturer's instructions to properly wire the light to the vehicle electrical system.
- 12.** With assistance, carefully position the Bumper Assembly up to the Frame Brackets, (**Figure 18**). Temporarily support the weight of the Bumper. **WARNING:** To avoid possible injury or damage to the vehicle, do not proceed until the bumper is fully and safely supported.
- 13.** Attach the Bumper to the Frame Brackets with the included (6) 12mm Hex Bolts, (12) 12mm Flat Washers, (6) 12mm Lock Washers and (6) 12mm Hex Nuts, (**Figure 18**). Do not tighten.
- 14.** Level and adjust the bumper and fully tighten all hardware.
- 15.** Transfer factory bumper wiring to new Fortis bumper and connect all sensors, if equipped.
- 16.** Insert (2) Plastic Plugs into the square holes in the front of the Bumper if front license plate is required. Reuse the factory screws to attach the license plate to the plastic plugs, (**Figure 19**).
- 17.** Do periodic inspections to the installation to make sure that all hardware is secure and tight.

To protect your investment, Do not use any type of polish or wax that may contain abrasives that could damage the finish. Mild soap may be used to clean the Front Bumper assembly.

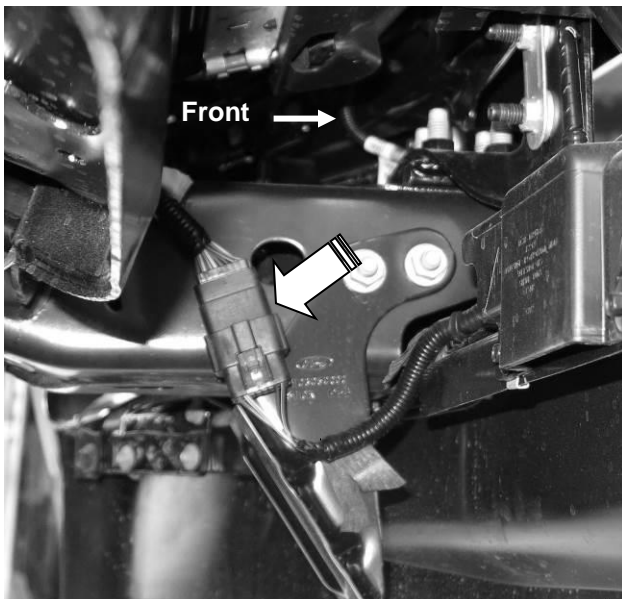

(Fig 1) Unplug wire harness from behind bumper (driver side pictured)

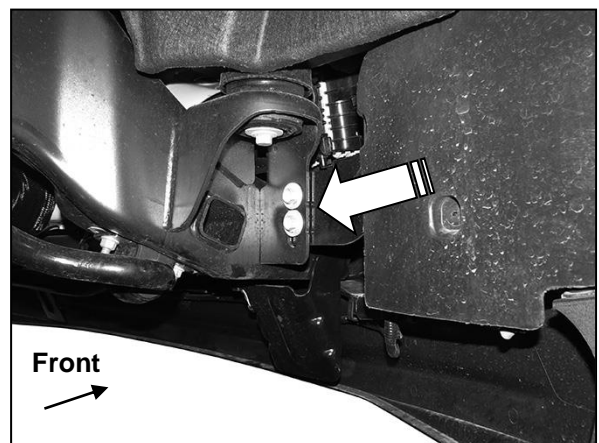

(Fig 2) Remove outer bumper support brackets between frame and bumper (arrow) [Passenger side shown]

**STEELCRAFT FORTIS FRONT BUMPER
2023-24 FORD SUPER DUTY**

Driver/left Side Installation Pictured



(Fig 3) Remove plastic cover around tow hook

WARNING! Do not remove bumper bolts unless the bumper is properly supported on blocks or stands or it may fall.

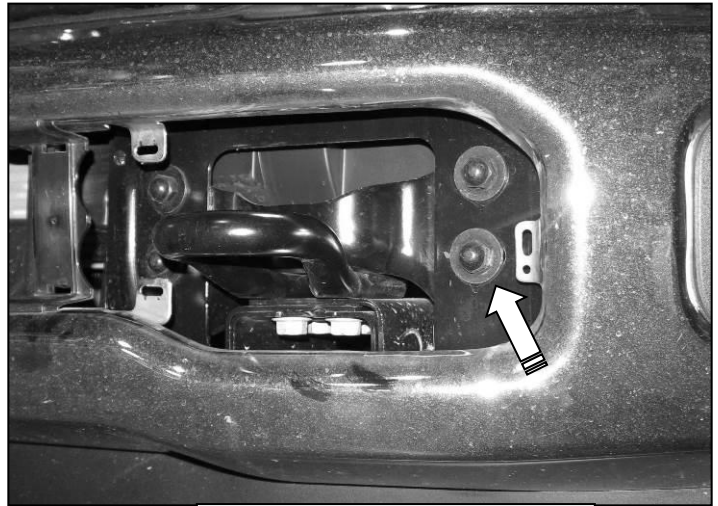

(Fig 4) Remove bumper bolts



(Fig 5) Remove the clips attaching rubber bumper trim to grille.

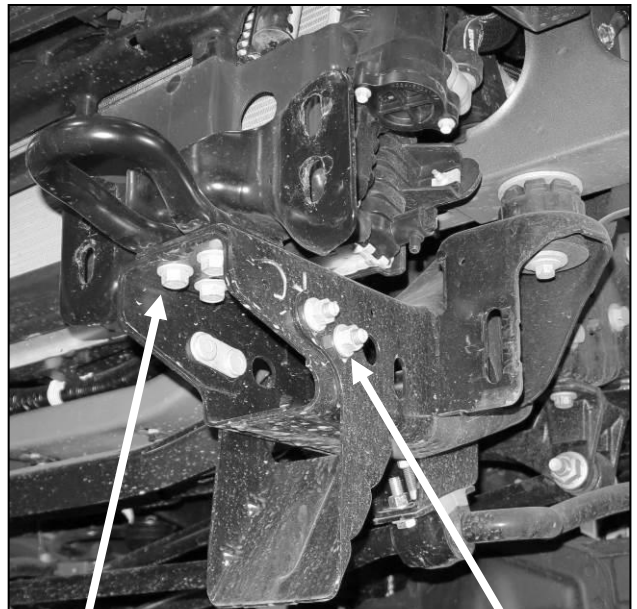

(Fig 6) Remove tow hook assembly and lower frame extension

Driver/left Side Installation Pictured

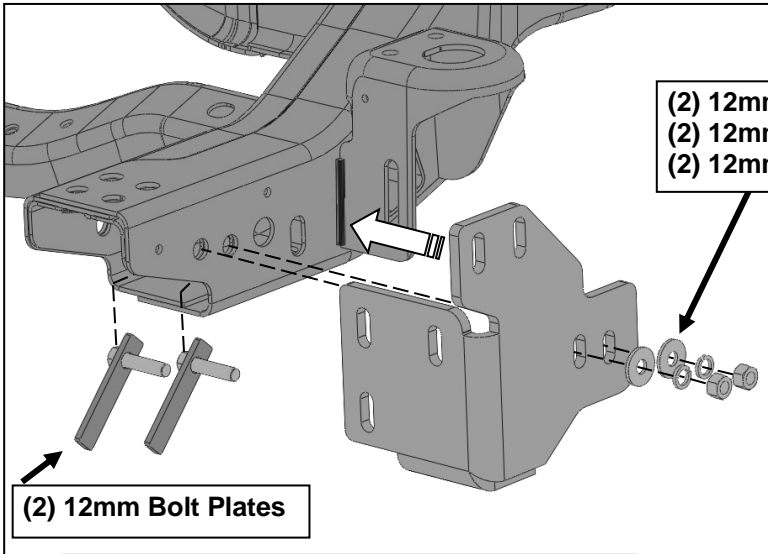

(Fig 7) Attach Frame Bracket to side of vehicle frame.

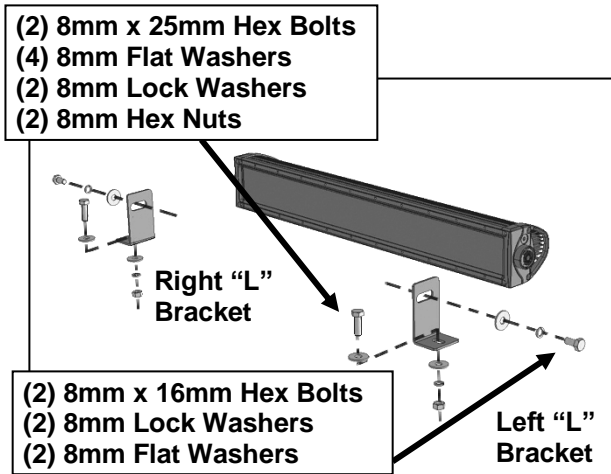

(Fig 9) Example of LED Light Installation

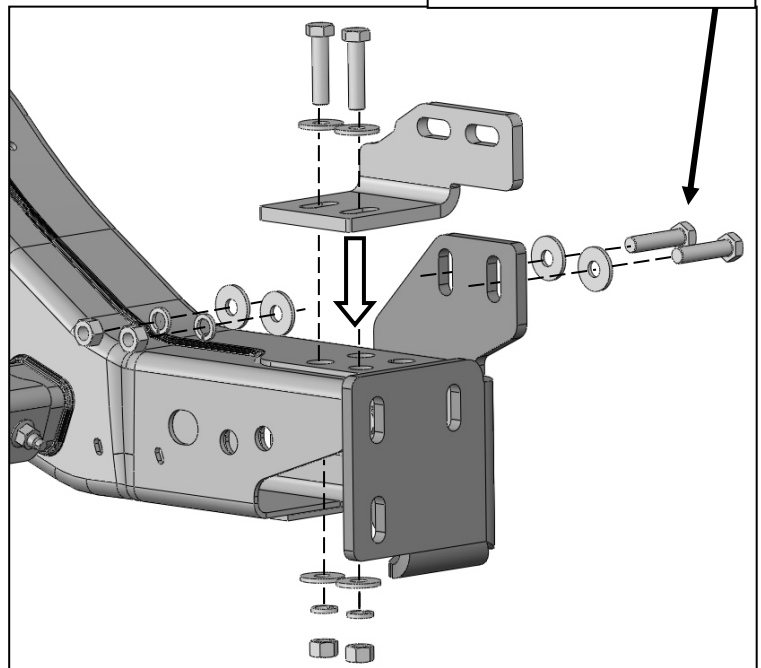

(Fig 8) Attach Support Bracket to top of frame and side of Frame Bracket.

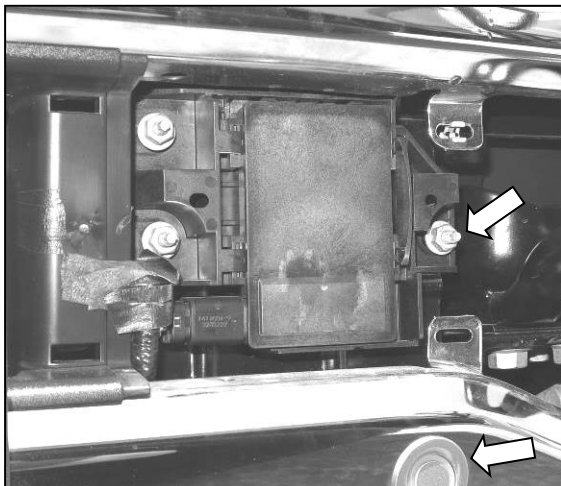

(Fig 10) Remove ACC Sensor, parking sensors and wiring harness from factory bumper, if equipped

**STEELCRAFT FORTIS FRONT BUMPER
2023-24 FORD SUPER DUTY**

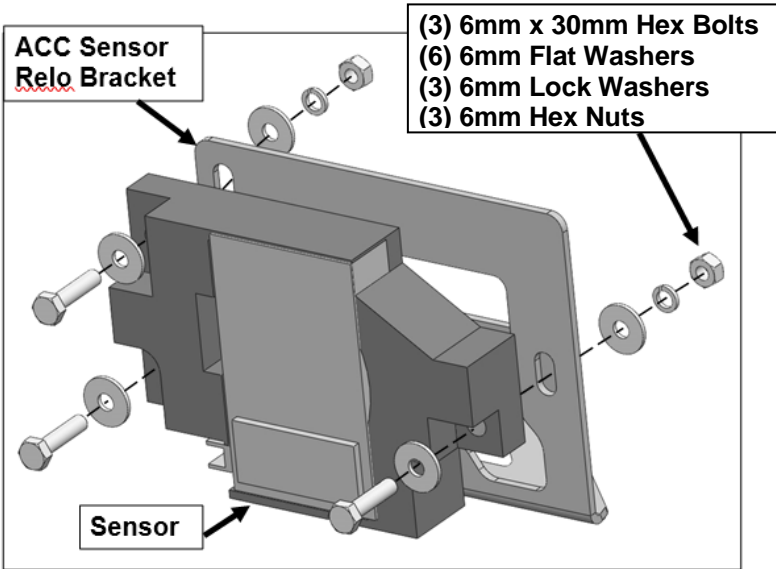

(Fig 11) Attach ACC sensor to ACC Sensor Relocation Bracket

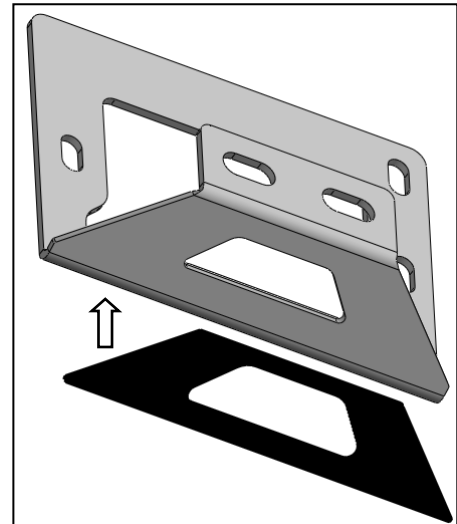

(Fig 12) Attach Foam Pad to bottom of ACC Sensor Relocation Bracket

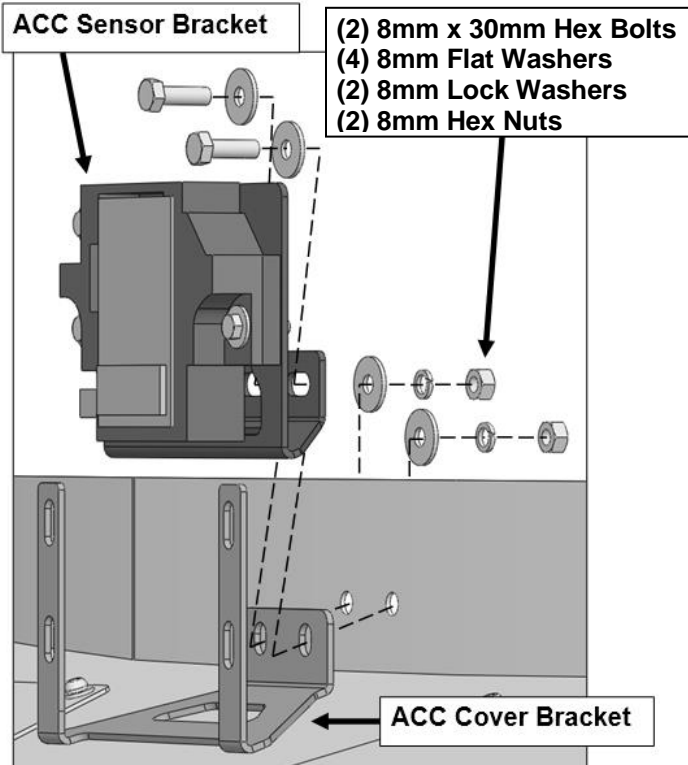

(Fig 13) Place ACC Sensor Relo Bracket within the ACC Cover Bracket and attach together to bumper

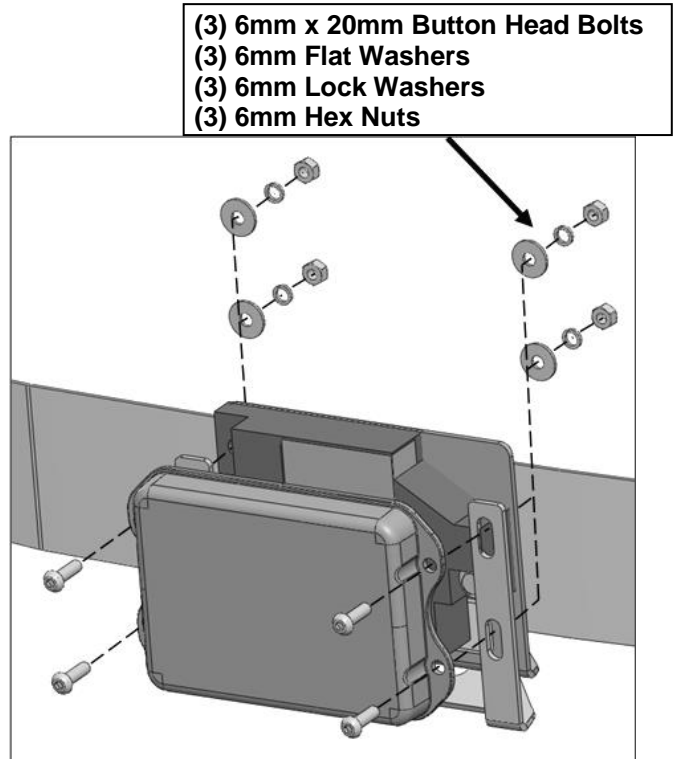

(Fig 14) Attach plastic ACC Cover to ACC Cover Bracket

**STEELCRAFT FORTIS FRONT BUMPER
2023-24 FORD SUPER DUTY**

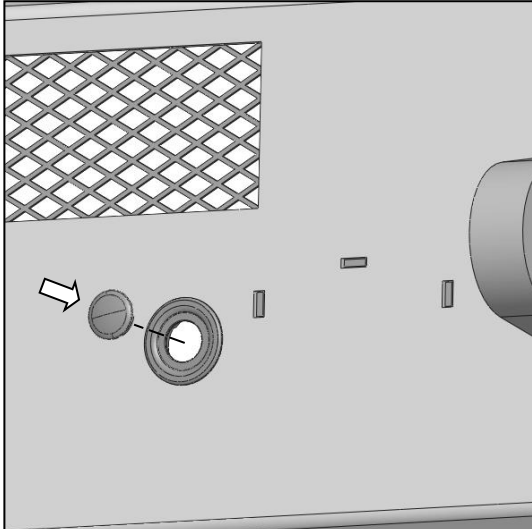

(Fig 15) Models without sensors: insert sensor plugs into the sensor hole (arrow)

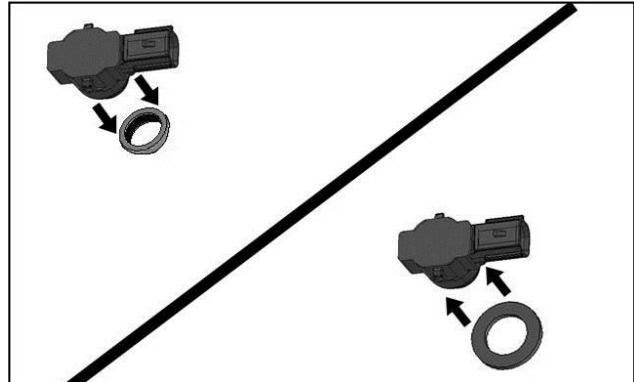

(Fig 16) Remove OE silicone seal from sensor. Slide large foam Seal over end of sensor.

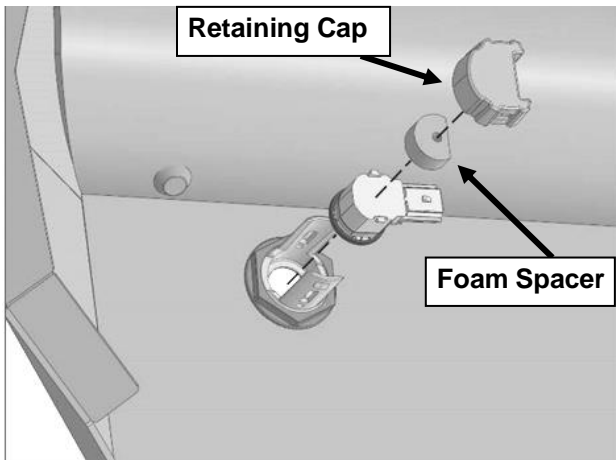

(Fig 17) Insert the sensor with seal into the sensor sleeve, followed by the foam spacer

WARNING! Do not crawl under bumper unless the bumper is properly supported on blocks or stands or the bumper may fall.

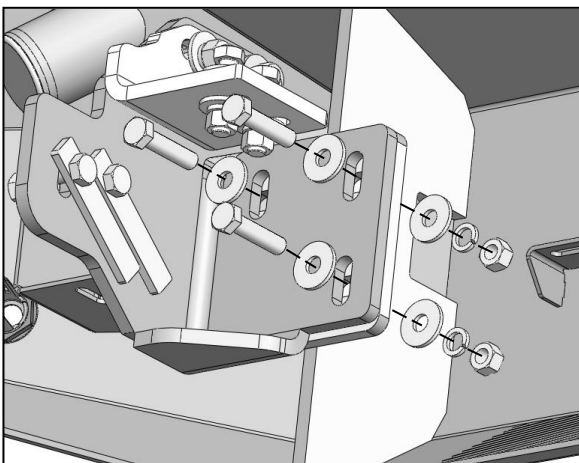

(Fig 18) Attach Bumper to Brackets

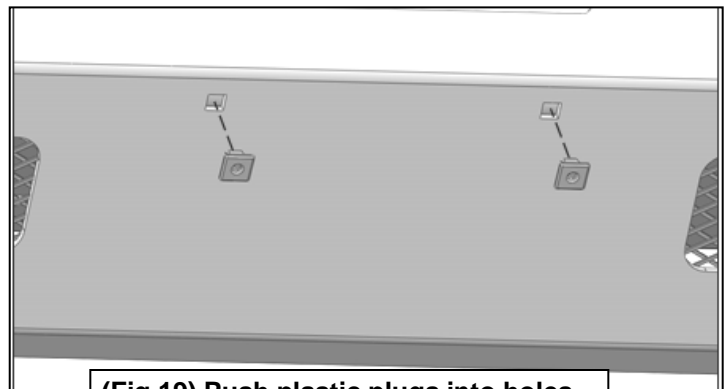

(Fig 19) Push plastic plugs into holes in Bumper for license plate if required