

**BRP PIPE FORCE FRONT BUMPER
2023-24 FORD SUPER DUTY**

PARTS LIST:

1	HDF Front Bumper Assembly	6	6mm x 30mm Hex Bolts
1	Driver/left Frame Bracket	4	6mm x 25mm Button Head Bolts
1	Passenger/right Frame Bracket	16	6mm x 18mm x 1.6mm Flat Washers
1	Adaptive Cruise Control, (ACC) Plastic Cover	10	6mm Lock Washers
1	Driver/left side ACC Sensor Bracket	10	6mm Hex Nuts
1	Passenger/right side ACC Sensor Bracket	2	8mm x 30mm Hex Bolts
1	ACC Cover Bracket	4	8mm x 28mm x 3mm flat washers
2	Plastic Plugs for license plate mount	2	8mm Nylon Lock Nuts
4	Parking Sensor Retaining Caps	1	4mm Allen Wrench
4	15.5mm x 25mm OD x 2mm Sensor Seals	1	2.5mm Allen Wrench
4	20mm x 10mm Foam Spacers	1	Sensor Cover Kit
4	Plastic Parking Sensor Plugs	8	4mm Self Tapping Screws
14	12-1.75mm x 50mm Hex Bolts	8	4mm x 20mm Socket Head Screws
32	12mm x 32mm x 3mm Flat Washers	8	4mm Hex Nuts
18	12mm Lock Washers	16	4mm x 8.65mm x .8mm Flat Washers
18	12-1.75mm Hex Nuts	8	4mm Lock Washers
4	12mm Bolt Plates		

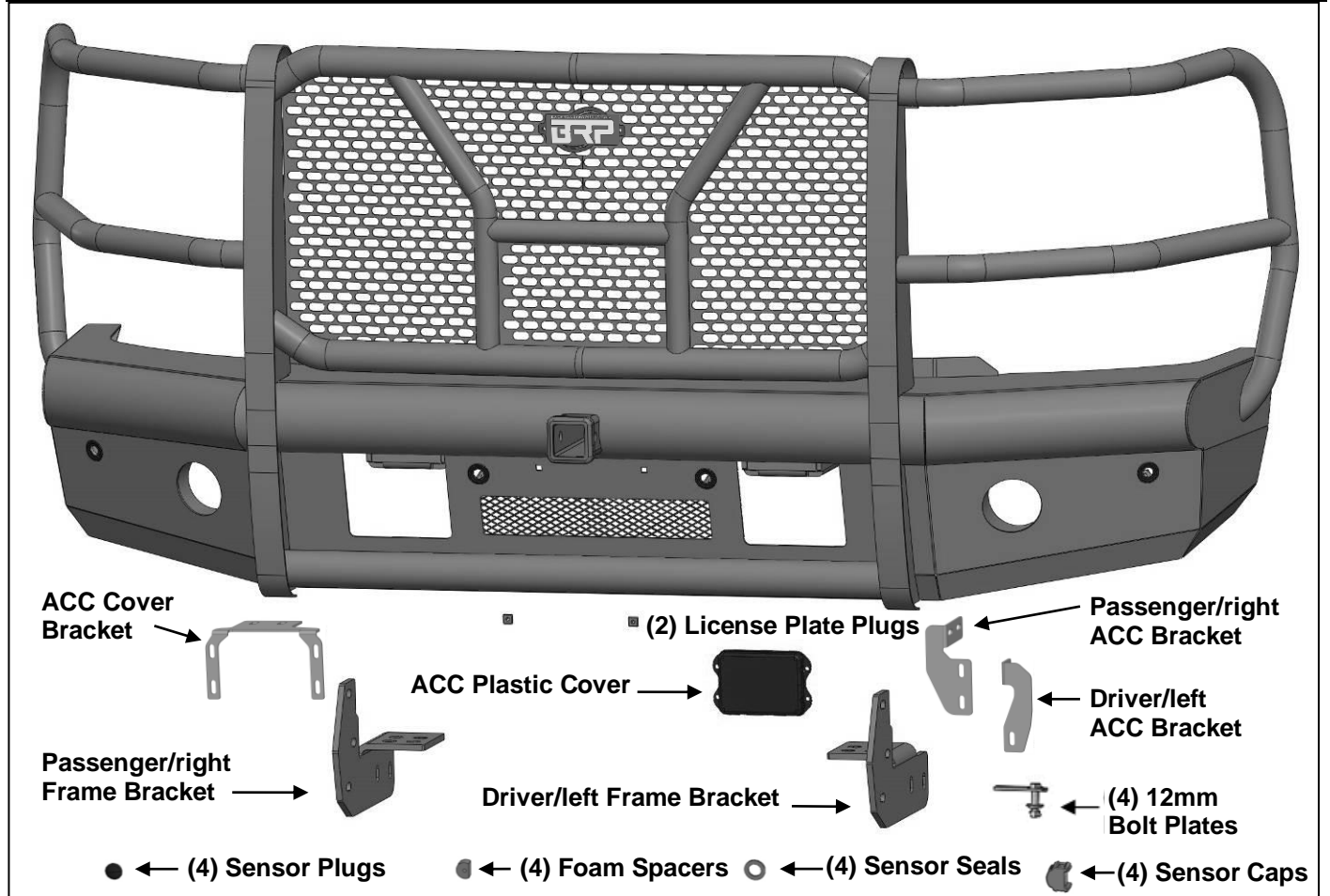

PROCEDURE:

REMOVE CONTENTS FROM BOX. VERIFY ALL PARTS ARE PRESENT. READ INSTRUCTIONS CAREFULLY BEFORE STARTING INSTALLATION. BUMPER IS HEAVY, ASSISTANCE IS HIGHLY RECOMMENDED TO AVOID POSSIBLE INJURY OR DAMAGE TO THE VEHICLE.

**BRP PIPE FORCE FRONT BUMPER
2023-24 FORD SUPER DUTY**

1. Remove the license plate. Unplug all wiring harnesses connecting bumper to vehicle **(Figure 1)**.
2. Remove the outer bumper supports attaching the outer ends of the bumper to the side of the frame, **(Figure 2)**. Remove the plastic covers from the tow hooks to uncover the bumper bolts, **(Figures 3 & 4)**.
3. Place blocks or jack stands under the front bumper to support it during mounting bolt removal. Once the bumper has been safely supported, remove the (8) factory bumper bolts, **(Figure 4)**.
WARNING! Assistance is required to hold the bumper in place during bolt removal to prevent the bumper from falling. Carefully slide the bumper off, over the tow hooks. There will be 2 plastic pins that attach the bumper to the grille that need to be pried off **(Figure 5)**.
4. Remove the driver/left side tow hook from the end of the frame, **(Figure 6)**. Next, remove the (4) factory hex nuts, lower frame extension and double bolt plates from the end of the frame, **(Figure 6)**. Repeat this Step to remove the passenger/right side tow hook and lower frame extension.
5. Reuse the factory hardware to attach the tow hooks to the brackets on the back of the HD Bumper, **(Figure 7)**. **NOTE:** if truck is equipped with adaptive cruise control do not install the driver side tow hook. The ACC sensor will be relocated to this location later in step 11.
6. Next, select the driver/left Frame Bracket. Slide the Bracket over the end of the frame. Line up the slots in the side of the Bracket with the holes in the outside of the frame. Select (2) 12mm Bolt Plates. Insert the Bolt Plates into the open end of the frame and out through the Bracket. Attach the Bracket to the Bolt Plates with (2) 12mm Flat Washers, (2) 12mm Lock Washers and (2) 12mm Hex Nuts, **(Figure 8)**. Leave loose at this time.
7. Attach the mounting tab on the top of the Bracket to the top of the frame at the original tow hook location with the included (4) 12mm x 50mm Hex Bolts, (8) 12mm Flat Washers, (4) 12mm Lock Washers and (4) 12mm Hex Nuts, **(Figure 9)**. Do not fully tighten hardware at this time.
8. Repeat **Steps 6 & 7** to attach the passenger/right Frame Bracket to the end of the frame.
9. Determine if truck is equipped with fog lights, otherwise skip to **step 10**.

Models with factory fog lights:

- a. Remove fog lights from the back of the OE bumper. Brackets may need to be removed to gain proper access **(Figure 10)**.
 - b. Move to the driver/left fog light opening. Place fog light into the fog light bracket on the new HD bumper. Make note of the plastic tabs that need to be removed for the light to sit flush. Use diagonal cutters to trim off tabs **(Figure 11 & 12)**.
 - c. Attach fog light to the Bracket with the included (4) 4mm x 20mm socket head screws, (8) 4mm x 9mm STD Flat Washers, (4) 4mm lock washers and (4) 4mm hex nuts, **(Figure 12)**.
 - d. Repeat to install the passenger/right fog light.
10. Determine if truck is equipped with front parking sensors.

For vehicles not equipped with front parking sensors.

- a. Select the included (4) Plastic Parking Sensor Plugs. From the front of the bumper, push plugs into sensor sleeves, **(Figure 18)**.

For vehicles equipped with front parking sensors.

- a. Remove the OE silicone seal from the end of the sensor. Remove the adhesive backing from the 15.5mm x 25mm x 2mm Foam Washer Seal. Slide the Foam Seal over front of sensor **(Figure 19)**.
 - b. Insert sensor with Foam Washer into sensor sleeve.
 - c. Place (1) Foam Spacer on back of sensor. Push Sensor Retaining Cap onto sensor mount and lock into mounting holes, **(Figure 20)**.
 - d. Repeat previous Steps to install remaining sensors.
11. Determine if truck is equipped with adaptive cruise control, (ACC).

Vehicles without Adaptive Cruise Control, skip to Step 12.

- a. Remove the 3 nuts securing the ACC sensor to the front of the OE bumper. **(Figure 13)**. Unplug the wiring harness and remove the sensor from the bumper.
- b. Select the plastic ACC cover and ACC cover bracket. Insert (4) 6mm x 25mm Button Head Bolts through the (4) holes on the ACC Plastic Cover to each side of the ACC cover bracket. Secure with (4) 6mm Flat Washers, (4) 6mm Lock Washers and (4) 6mm Hex Nuts, **(Figure 14)**.

**BRP PIPE FORCE FRONT BUMPER
2023-24 FORD SUPER DUTY**

- c. Attach the cover and bracket assembly to the bottom of the driver side tow hook mount on the bumper with the included (2) 8mm x 30mm Hex Bolts, (4) 8mm Flat Washers and (2) 8mm Hex Nuts, **(Figure 15)**.
 - d. Select the ACC sensor, Left ACC Bracket and Right ACC Bracket. Position the sensor between the Left and Right brackets **(Figure 16)**. Attach the sensor to the brackets with (3) 6mm x 30mm Hex Bolts, (6) 6mm Flat Washers, (3) 6mm Lock Washers and (3) 6mm Hex Nuts. Do not tighten hardware
 - e. Attach the sensor and bracket assembly to the sides of the driver side tow hook mount with the included (3) 6mm x 30mm Hex Bolts, (6) 6mm Flat Washers, (3) 6mm Lock Washers and (3) 6mm Hex Nuts, **(Figure 17)**.
12. With assistance, carefully position the Bumper Assembly to the outside of the Frame Brackets. Temporarily support the weight of the Bumper. **WARNING:** To avoid possible injury or damage to the vehicle, do not proceed until the bumper is fully and safely supported.
13. Attach the Bumper to the outside of the Frame Brackets with the included (6) 12mm x 50mm Hex Bolts, (12) 12mm Flat Washers, (6) 12mm Lock Washers and (6) 12mm Hex Nuts, **(Figure 21)**. Do not fully tighten hardware at this time.
14. Level and adjust the bumper and fully tighten all 12mm hardware to 65-70ft-lbs.
15. Level and adjust the ACC sensor. Position plastic ACC cover so the sensor is centered behind it.
16. Insert (2) Plastic Plugs into the Bumper. Reuse factory hardware to attach license plate to Plugs. On models with grille emblem mounted factory camera, remove the center window screen, **(Figure 22)**.
17. Remove the factory wiring harness from the old bumper and reattach to the new HD bumper.
18. Do periodic inspections to the installation to make sure that all hardware is secure and tight.

To protect your investment, Do not use any type of polish or wax that may contain abrasives that could damage the finish. Mild soap may be used to clean the Bumper Assembly

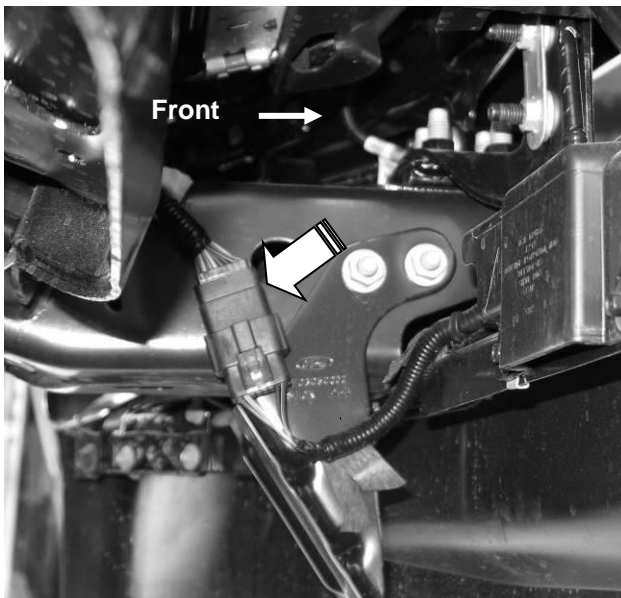

**(Fig 1) Unplug all wiring harnesses.
(Inside of driver side frame shown)**

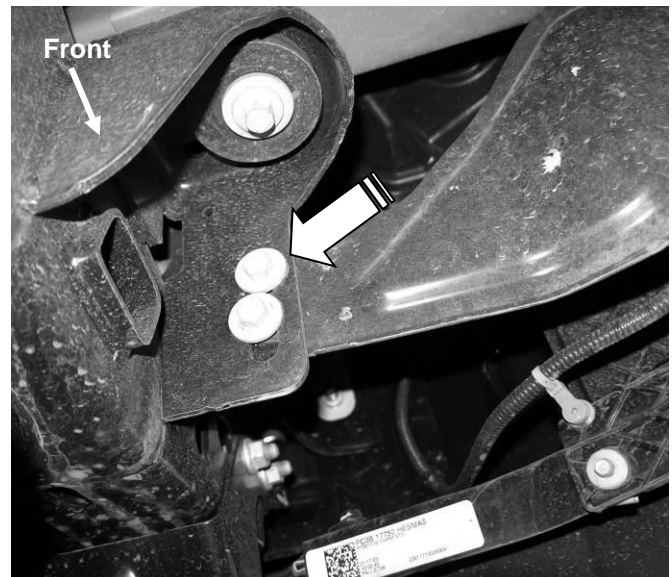

**(Fig 2) Remove outer bumper support
brackets between frame and bumper (arrow)
[Passenger side shown]**

**BRP PIPE FORCE FRONT BUMPER
2023-24 FORD SUPER DUTY**

Driver Side Installation Pictured

WARNING! Do not remove bumper bolts unless the bumper is properly supported on blocks or stands or the bumper may fall.



(Fig 3) Remove plastic cover around tow hook



(Fig 4) Remove bumper bolts (driver side pictured)



(Fig 5) Remove the clips attaching rubber bumper trim to grille.

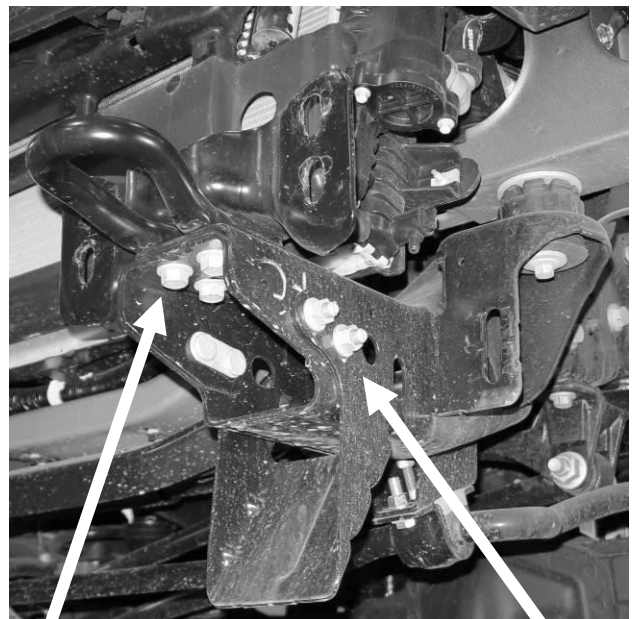

(Fig 6) Remove tow hook assembly and lower frame extension

**BRP PIPE FORCE FRONT BUMPER
2023-24 FORD SUPER DUTY**

Driver Side Installation Pictured



(Fig 7) Reuse factory hardware to attach tow hook to mount on back of HD bumper

- (2) 12mm Bolt Plates**
- (2) 12mm Flat Washers**
- (2) 12mm Lock Washers**
- (2) 12mm Hex Nuts**

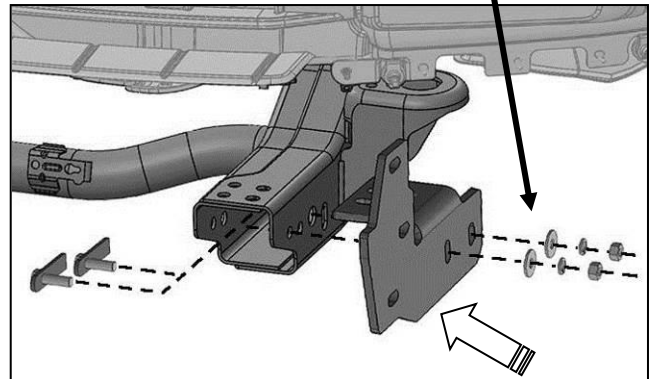

(Fig 8) Insert Bolt Plates into open end of frame. Attach Bracket to side of frame

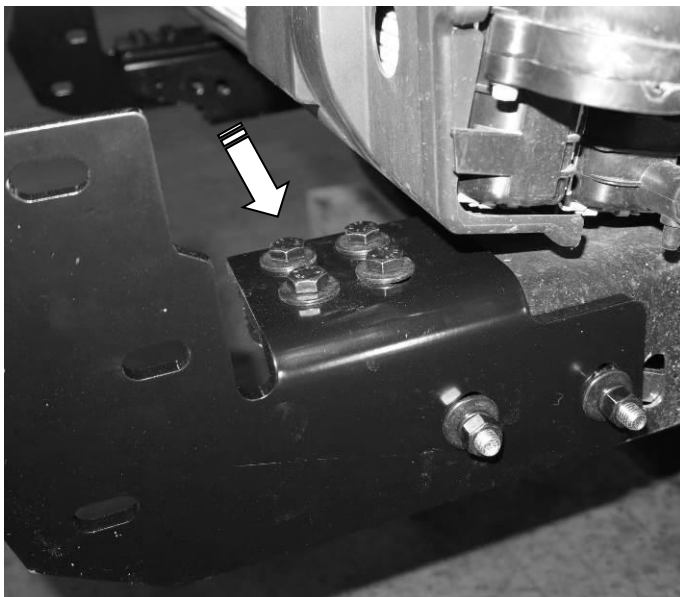

(Fig 9) Attach tab on Bracket to top of frame



(Fig 10) Unplug and remove fog lights from OE bumper (if equipped)

Driver Side Installation Pictured

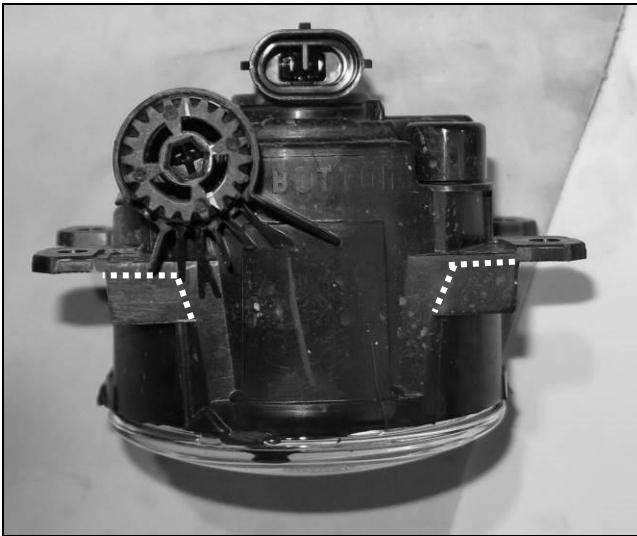

(Fig 11) Trim plastic tabs off fog light

- (8) 4mm x 20mm Screws
- (16) 4mm Flat Washers
- (8) 4mm Lock Washers
- (8) 4mm Hex Nuts

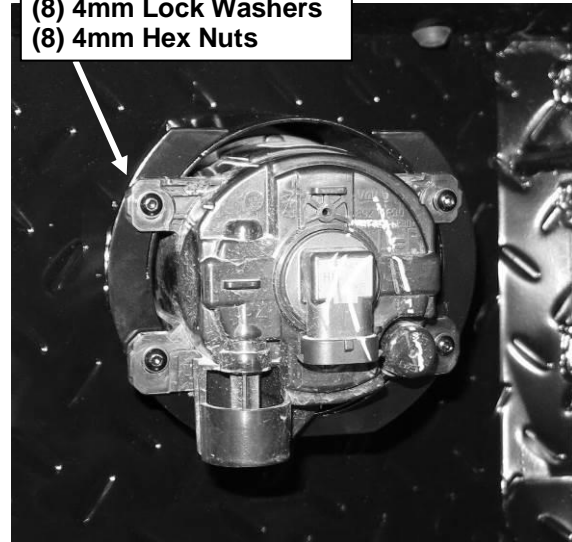

(Fig 12) Attach fog lights to bumper using 4mm hardware



(Fig 13) Remove adaptive cruise control "ACC" and parking sensors (if equipped)

- (4) 6mm Button Head Bolts
- (4) 6mm Flat Washers
- (4) 6mm Lock Washers
- (4) 6mm Hex Nuts

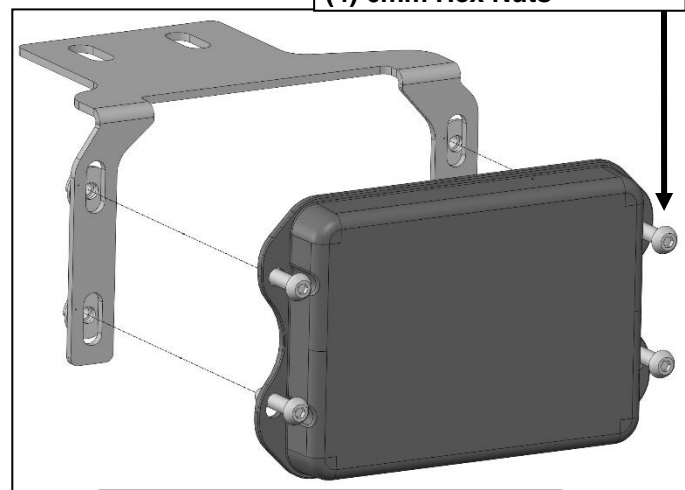

(Fig 14) Assemble ACC cover to the ACC cover bracket

Driver Side Installation Pictured

- (2) 8mm x 30mm Hex Bolts
- (4) 8mm Flat Washers
- (2) 8mm Hex Nuts

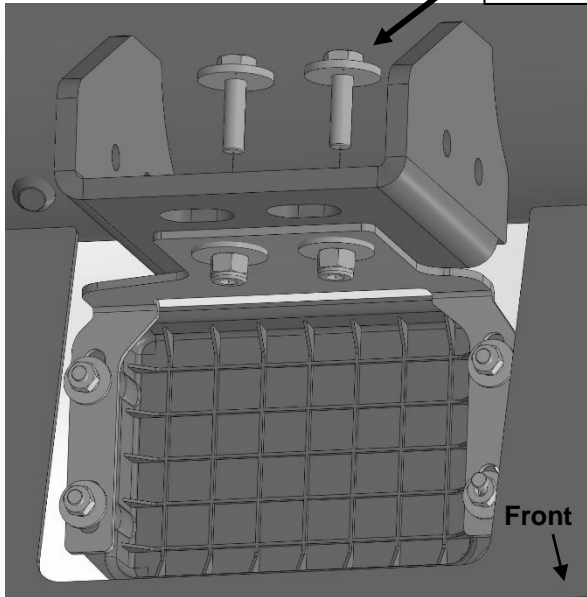

(Fig 15) Attach ACC cover assembly to the driver side tow hook bracket

- (3) 6mm x 30mm Hex Bolts
- (6) 6mm Flat Washers
- (3) 6mm Lock Washers
- (3) 6mm Hex Nuts

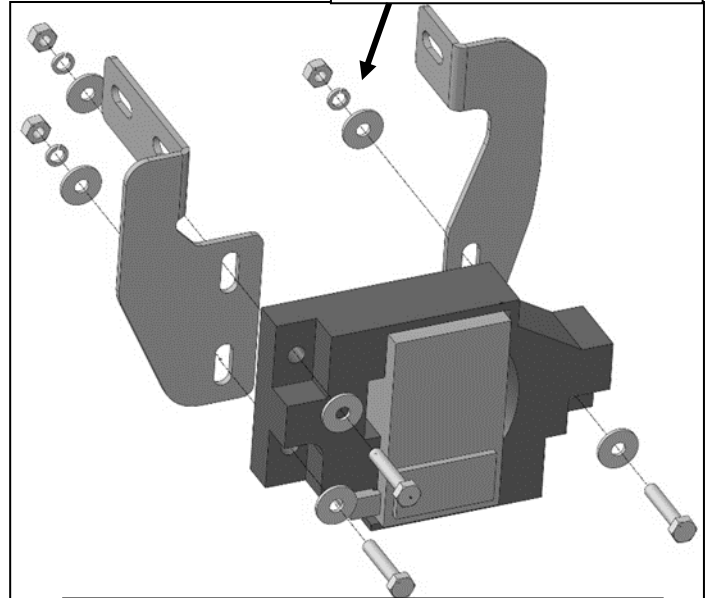

(Fig 16) Attach ACC sensor to ACC brackets

- (3) 6mm x 30mm Hex Bolts
- (6) 6mm Flat Washers
- (3) 6mm Lock Washers
- (3) 6mm Hex Nuts

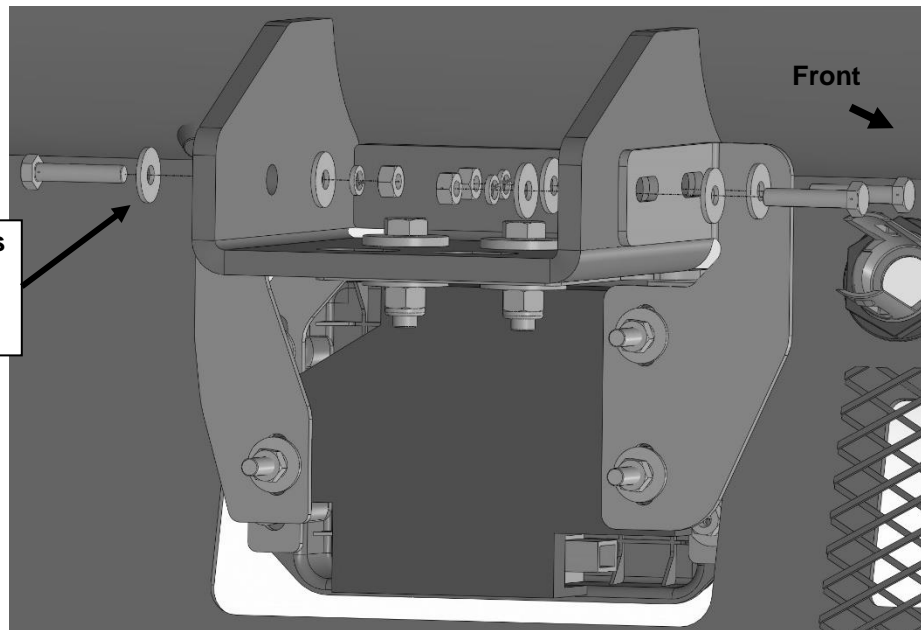

(Fig 17) Attach ACC sensor assembly to driver side tow hook bracket

**BRP PIPE FORCE FRONT BUMPER
2023-24 FORD SUPER DUTY**

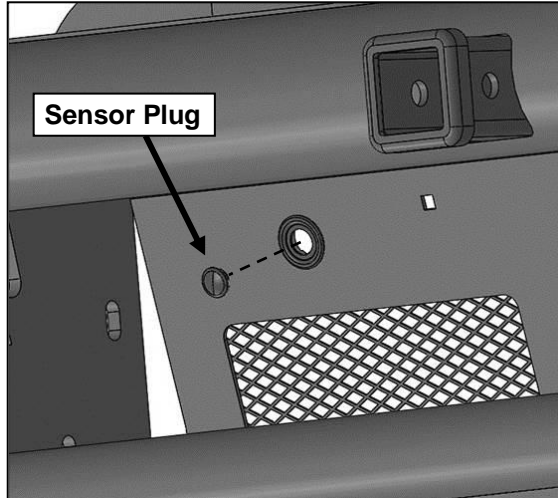

(Fig 18) Models without sensors: insert sensor plugs into the sensor hole

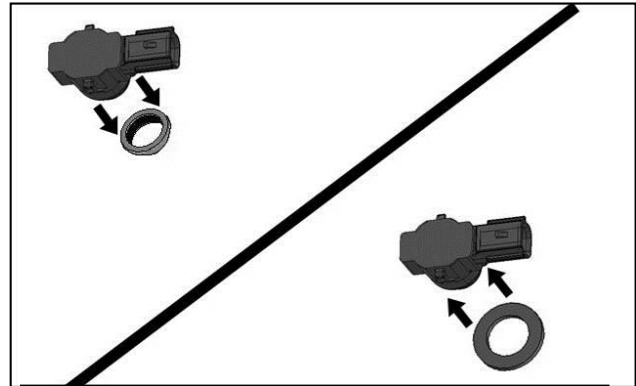

(Fig 19) Remove OE silicone seal from sensor. Slide large Seal over end of sensor

WARNING! Do not crawl under bumper unless the bumper is properly supported on blocks or stands or the bumper may fall.

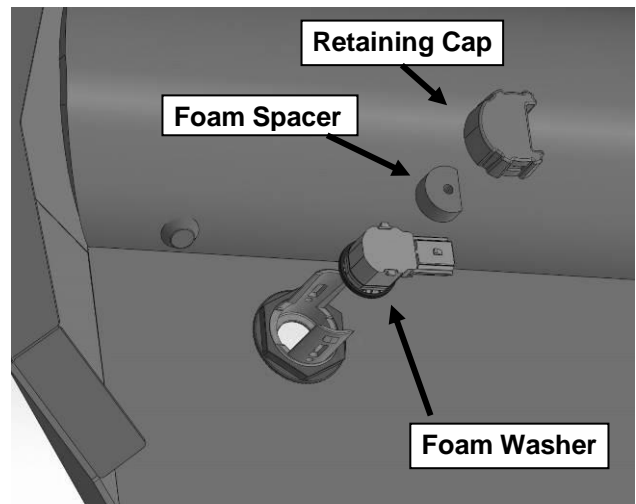

(Fig 20) Insert the sensor with seal into the sensor sleeve, followed by the foam spacer and retaining cap

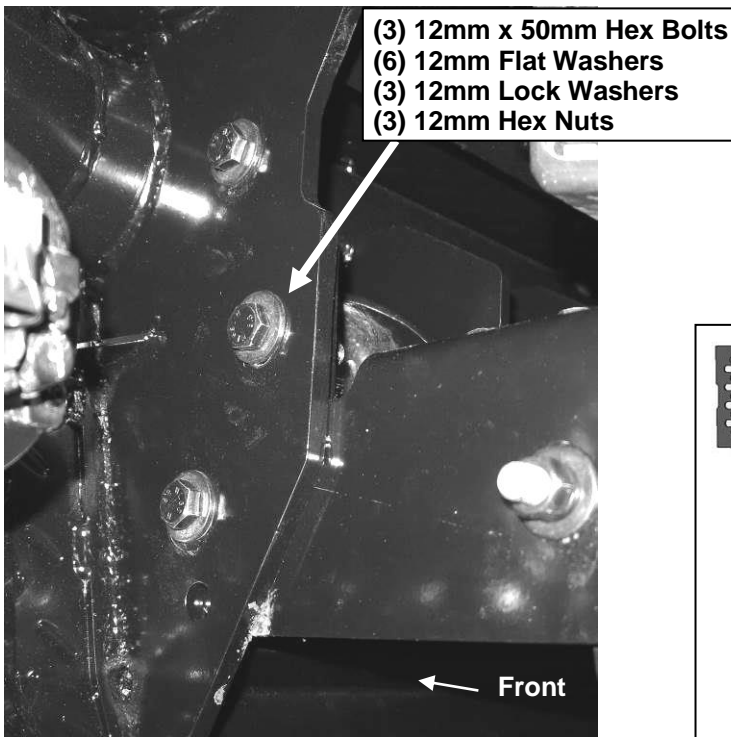

(Fig 21) Attach bumper to frame brackets

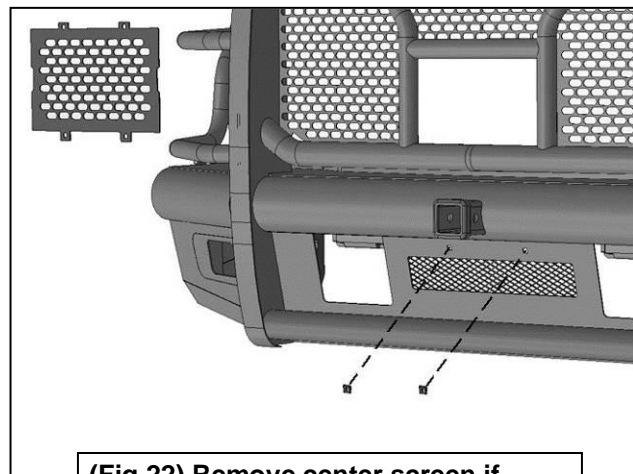

(Fig 22) Remove center screen if equipped with grille mounted camera. Install Plastic Plugs for license plate