

Hand Pallet Truck **[MB-P series]**

One of best selling in the world.

- ✘ Reliable hydraulic pump. Unique technology on this pump, descending speed is controllable that irrespective of the weight of the load.
- ✘ Bushings in key points.
- ✘ Easy pallet entry and exit.
- ✘ Durable frame of C type fork.
- ✘ Conforms to EN1757-2.

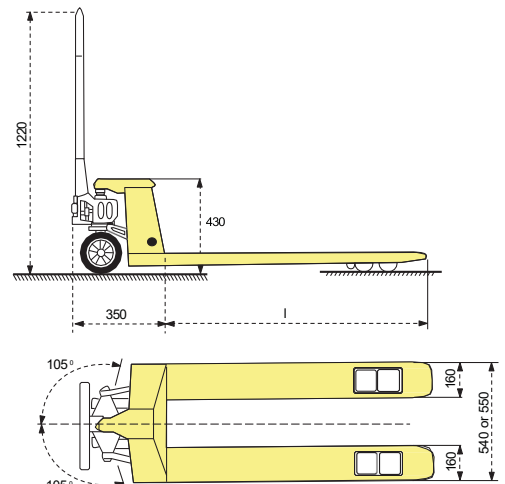

(mm)

Model		MB-P20		MB-P25		MB-P30	
Capacity	(kg/lbs)	2000/4400		2500/5500		3000/6600	
Lifting Height	(mm/inch)	115/5"					
Max. Fork Height	(mm/inch)	200 (or 190) / 7 ⁷ / ₈ " (or 7 ³¹ / ₆₄ ")					
Min. Fork Height	(mm/inch)	85 (or 75) / 3 ¹¹ / ₃₂ " (or 2 ⁶¹ / ₆₄ ")					
Fork Length	l (mm/inch)	1150/45"	1220/48"	1150/45"	1220/48"	1150/45"	1220/48"
Fork Width	(mm/inch)	160/6"	160/6"	160/6"	160/6"	160/6"	160/6"
Width Overall Forks	(mm/inch)	540(550)/21"(22")	685/27"	540(550)/21"(22")	685/27"	540(550)/21"(22")	685/27"
Load Roller	(mm/inch)	Tandem $\Phi 80 \times 70$ / $\Phi 39/64$ " $\times 2^{3/4}$ " , Single $\Phi 80 \times 93$ / $\Phi 39/64$ " $\times 3^{21/32}$ " Nylon, Polyurethane					
Steering Wheel	(mm/inch)	$\Phi 180$ / $\Phi 7$ " Nylon, Polyurethane or Rubber ($\Phi 200$ / $\Phi 8$ " available)					
Net Weight	(kg/lbs)	77/169	80/176	80/176	82/180	85/187	87/191

Note: Special fork size available.