

IT'S NOT A CART. IT'S A KNAACK®.

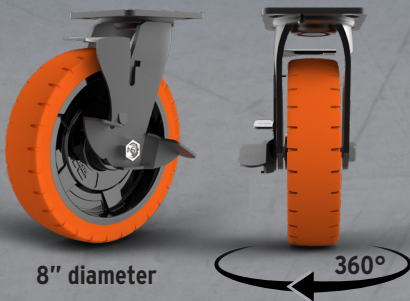

MAXIMUM MOBILITY



- 60% larger diameter & 2X wider wheels designed for the jobsite

DURABILITY



- Up to 750 lb payload
- 2X greater wall thickness
- One-piece handle design

SECURITY



- Fully integrated 16-gauge steel panels enclosed by tongue & groove design
- Up to 70% reduction of assembly time



BEYOND MAXIMUM SECURITY™

MAXIMUM MOBILITY

Built for any jobsite terrain, oversized 8" rubber wheels, 60% larger diameter, and 2X wider than traditional cart castors. Swivel wheels and an ergonomic handle alleviate fatigue when pushing or pulling maximum payloads.



60% LARGER DIAMETER, 2X WIDER

than traditional cart castors

Industrial grade mounting plate

Heavy duty wheel frame

Durable, nonmarring wheels designed for all phases of construction

Designed for higher load rating and easier to traverse jobsite obstacles

Heavy duty ball bearing swivel for smooth turns

Industrial grade wheel lock for safety

Roller bearing construction for reduced friction & enhanced mobility

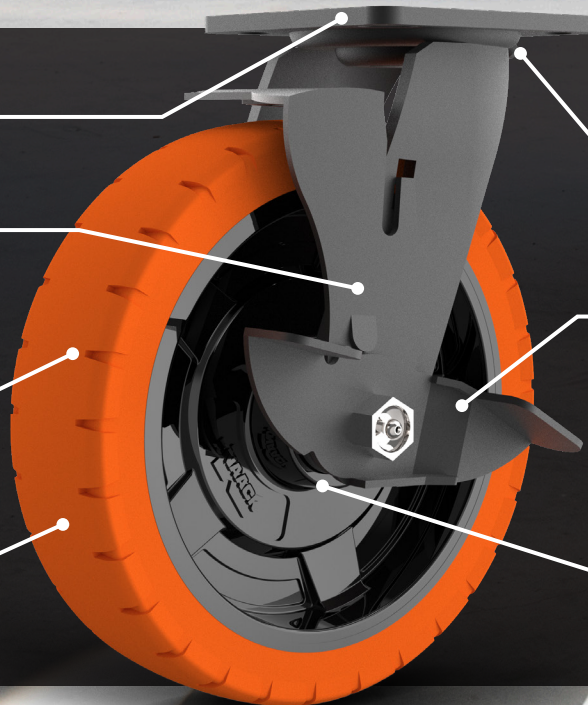



DURABILITY

Built with a 50% higher load-rating than traditional carts used on jobsites.



SECURITY & ASSEMBLY

16-gauge steel panels with lockable steel doors to prevent theft. Easily put together in less than 10 minutes, saving up to 70% in assembly time. Reducing complexity with only one type of hardware required to assemble.





ARMOURED TRANSPORT



Flat top design for easier materials transport and work surface

Ergonomic handle to alleviate fatigue when pushing and pulling maximum payloads

2X wall thickness for jobsite durability and payloads



Taller than light-duty carts for an elevated work platform

Approx. Dimensions:
45.5" L x 27" W x 37" H



Electrical cord pass through with rubber grommet

Up to 70% reduction of assembly time



Don't need security? Meet the KT-01.

The KNAACK Transport provides the same mobility, durability, and easy assembly without the security armour.



KT-01
(no armour)

PAIR WITH KNAACK®
PLANZBOARD™
to create a Secure Mobile
Planning Station for the jobsite.
Visit KNAACK.COM to
check compatibility



PART NO.	DESCRIPTION	MATERIAL	SHIPPING DIMENSIONS H x W x D (in)	SHIPPING WEIGHT (lbs)	UPC
KAT-01	KNAACK Armoured Transport	Steel & HDPE	12 x 29 x 47.5	123	783965071871
KT-01	KNAACK Transport (no armour)	HDPE	9 x 29 x 47.5	75	783965072267

KAT-01 includes: Top tray, bottom tray, 4 legs, 2 fixed wheels, 2 swivel and locking wheels, armour panels, hardware

KT-01 includes: Top tray, bottom tray, 4 legs, 2 fixed wheels, 2 swivel and locking wheels, hardware

800-456-7865 • KNAACK.COM

Werner Co. 420 Terra Cotta Ave, Crystal Lake, IL 60014