

# WoodMaxx

Power Equipment Ltd.



## WM-8M WOOD CHIPPER OPERATOR'S MANUAL

YOU MUST READ THIS MANUAL BEFORE USING THIS EQUIPMENT

# TABLE OF CONTENTS

Introduction . . . . .	2
Safety Information . . . . .	2
Driveline Safety . . . . .	7
Assembly Instructions . . . . .	10
PTO Shaft Sizing Instructions . . . . .	20
General Operation . . . . .	24
Lubrication . . . . .	26
Knife Changing / Adjusting . . . . .	27
Flywheel Knife Sharpening . . . . .	30
Flywheel Knife Care . . . . .	31
Clearing Flywheel Housing . . . . .	32
Infeed Drive Axle Power Belt . . . . .	33
Changing / Adjusting Drive Belt . . . . .	34
Maintain Infeed Drive Axle . . . . .	35
Maintenance / Storage . . . . .	36
Torque Specifications . . . . .	37
Safety Labels . . . . .	38
Troubleshooting . . . . .	40
Parts & Diagrams . . . . .	41
Warranty . . . . .	56

All content in this manual; pictures, and text are the sole property of  
**WoodMaxx™ Power Equipment Ltd.** © 2013-19. No unauthorized reproduction.

# INTRODUCTION

**CONGRATULATIONS!** You have just purchased a **WoodMaxx™ WM-Series Wood Chipper**, the strongest, safest and the most compact PTO Wood Chipper available. We have compiled this owner's manual to help you understand and appreciate your chipper. By taking a few minutes to read this manual and understand the maintenance instructions, it will give you better performance and extend the life of your chipper. You must read this manual before operating the chipper.

## Using This Manual

This Operator's Manual is designed to help familiarize you with safety, assembly, operation, adjustments, troubleshooting, and maintenance. Read this manual and follow the recommendations to help ensure safe and efficient operation.

The information contained within this manual was current at the time of printing. Some parts may change slightly to assure you of the best performance. To check for updates refer to our website at **www.WoodMaxx.com** or call **1-855-966-3629** to speak to one of our representatives.

## Owner Assistance

If customer service or repair parts are required please contact **WoodMaxx** at **1-855-966-3629**. WoodMaxx has trained personnel, repair parts and equipment needed to service this machine. The parts on your machine have been specially designed and should only be replaced with genuine WoodMaxx parts. Please reference your order number or serial number when calling.

# SAFETY INFORMATION

## Safe Operation Tips

Thoroughly read and understand the instructions given in this manual before operation. Refer to the safety decals in the back of this manual. Read all instructions noted on them.

Do not allow anyone to operate this equipment who has not fully read and comprehended this manual and who has not been properly trained in the safe operation of the equipment.

- Operator should be familiar with all functions of the unit.
- Make sure all guards and shields are in place and secured before operating the equipment.
- Dismounting from a moving tractor could cause serious injury or death.
- Do not stand between the tractor and the implement during hitching.

# SAFETY INFORMATION

- Watch out for wires, trees, etc., when raising and moving implement. Make sure all persons are clear of working area.
- Turning tractor too tight may cause implement to ride up on wheels. This could result in injury or equipment damage.
- Visually inspect the infeed bin and the flywheel before applying power to ensure that the chipper head is clear, all the bolts are clear, and the flywheel knives clear the flywheel housing and the bed knife.
- Bystanders must be at a safe distance from chipper during operation.
- Children should NEVER operate, or be near the chipper during operation.
- Make sure the PTO shaft does not come apart or bottom out during the normal lifting range. Damage resulting from an improperly sized PTO shaft is not covered under warranty.
- Check the chip pile to see if the knives need to be serviced. Long slivers in the chip pile are one of the best indicators of dull knives.
- It is NOT recommended to operate the chipper in temperatures below freezing. Hardened steel (as used on knives) can become brittle in temperatures below freezing and may result in breakage.
- Always keep the guards and chip deflector installed properly while operating the chipper.
- Never leave the chipper running unattended.
- Do not attempt alterations, repairs, or adjustments while the flywheel is turning. Always disconnect the PTO, stop the tractor's motor, and put the keys in your pocket prior to attempting any alterations, repairs or adjustments.
- Keep hands, feet, clothing and other extremities out of and away from the hopper (infeed bin) and any power driven parts. Wear snug fitting clothing to avoid entanglement with moving parts.
- No loose clothing should be worn around the chipper. Personal injury can occur if someone or something turns the flywheel over when the knives are being checked or the cutter bar is being adjusted. The flywheel has enough residual energy to easily remove fingers.
- Point the discharge chute away from doorways, sidewalks, or any other area where your view is obstructed. The chute should be pointed downwind when possible. This will keep the chips from blowing back in the operator's direction.

## A Note to All Users

List of warnings and cautions cannot be all-inclusive. If situations occur that are not covered by this manual, the operator must apply common sense and operate this Wood Chipper in a safe manner. If you have any questions, please contact **WoodMaxx** at **(855) 966-3629**.

# SAFETY INFORMATION

## Safety Alert Symbols

The SAFETY ALERT SYMBOL indicates there is a potential hazard to personal safety involved and extra safety precaution must be taken. When you see this symbol, be alert and carefully read the message that follows it. In addition to design and configuration of equipment, hazard control and accident prevention are dependent upon the awareness, concern, prudence and proper training of personnel involved in the operation, transport, maintenance and storage of equipment.



### DANGER

This symbol indicates an imminently hazardous situation which, if not avoided, will result in death or serious injury. This signal word is limited to the most extreme situations, typically for machine components that, for functional purpose, cannot be guarded.



### WARNING

This symbol indicates a potentially hazardous situation which, if not avoided, could result in death or serious injury, and includes hazards that are exposed when guards are removed. It may also be used to alert against unsafe practices.



### CAUTION

This symbol indicates a potentially hazardous situation which, if not avoided, may result in minor or moderate injury. It may also be used to alert against unsafe practices.

# SAFETY INFORMATION

## Use Safety Lights and Devices

- Slow moving tractors, self-propelled equipment, and towed implements can create a hazard when driven on public roads. They are difficult to see, especially at night.
- Flashing warning lights and turn signals are recommended whenever driving on public roads. Use lights and devices provided with implement.

## Transport Machinery Safely

- Comply with state and local laws.
- Maximum transport speed for any WoodMaxx implement is 20 mph on paved surface and 10 mph maximum on unpaved surface. Do not exceed. Never travel at a speed which does not allow adequate control of steering and stopping. Rough terrain requires a slower speed. Traveling at excessive speed on rough terrain that causes violent shaking or bouncing of the implement will damage the attachment point on the implement and/or the tractor. This type of damage is not covered under warranty.
- Use the following maximum speed - for paved surfaces only:
  - 20 mph when weight is less than or equal to the weight of tractor.
  - 10 mph when weight is more than the weight of the tractor.

## Keep Riders Off Machinery

- Riders obstruct the operator's view, they could be struck by foreign objects or thrown from the machine.
- Never allow children to operate equipment.

## Practice Safe Maintenance

- Understand procedure before doing work. Use proper tools and equipment. Refer to Operator's Manual for additional information.
- Work in a clean dry area.
- Lower the implement to the ground, put tractor in park, turn off engine, and remove key before performing maintenance.
- Allow implement to cool completely.
- Do not grease or oil implement while it is in operation.

# SAFETY INFORMATION

## Prepare For Emergencies

- Be prepared if a fire starts.
- Keep a first aid kit and fire extinguisher handy.
- Keep emergency numbers for doctor, ambulance, hospital and fire department near phone.

## Avoid High Pressure Fluids Hazard

- Escaping fluid under pressure can penetrate the skin causing serious injury.
- Avoid the hazard by relieving pressure before disconnecting hydraulic lines.
- Use a piece of paper or cardboard, not body parts, to check for suspected leaks. Wear protective gloves and safety glasses or goggles when working with hydraulic systems.
- If an accident occurs, see a doctor immediately. Any fluid injected into the skin must be treated within a few hours or gangrene may result.

## Wear Protective Equipment

- Protective clothing and equipment should be worn.
- Wear clothing and equipment appropriate for the job. Avoid loose fitting clothing.
- Prolonged exposure to loud noise can cause hearing impairment or hearing loss. Wear suitable hearing protection such as earmuffs or earplugs.
- Operating equipment safely requires the full attention of the operator. Avoid wearing radio headphones while operating machinery.

### Protective Gear Required:

- Wrap around safety glasses
- Ear plugs
- Leather gloves
- Steel-toe work boots
- Heavy pants
- Long sleeved shirt

# DRIVELINE SAFETY

Agriculture and forestry are recognized as one of the most hazardous of occupations. Today's farmer spends long hours in close proximity to increasingly complex and powerful machinery.

To avoid accidents, everyone from the component supplier and the company who manufacturers and assembles the machinery, to the dealers and ultimately the actual user, must keep safety in mind. The checklist below relates to the drive line of agricultural implements, general safety literature, and the standards published by the American Society of Agricultural Engineers.

## DRIVELINE SAFETY CHECKLIST

**Driveline Specifications** – The first step towards safe applications is to specify and test the driveline so that it operates properly under expected field conditions.

- ✓ Specify and test the proper size joints and telescoping members based upon the power required by the implement, speed of rotation, joints angles, shock loads, and expected life.
- ✓ Test the hitch geometry to prevent the drive line from:
  - Extending beyond the recommended maximum length.
  - Bottoming out.
  - Reaching a position that allows universal joints to lock.
  - Exceeding the maximum allowable angle for constant velocity of the universal joints.

Information concerning these parameters may be found in all driveline manufacturer's catalogs.

- ✓ Specify and test telescoping members to allow the lowest possible thrust loads, considering the expected working conditions.
- ✓ Specify and test torque limiters to control excessive shock loads.
- ✓ Where necessary, specify and test overrunning clutches to prevent inertial loads from overpowering the tractor.



# DRIVELINE SAFETY CHECKLIST

**Hazard Reduction** – The second step in specifying a safe driveline application is to strive to eliminate as many hazards as possible

- ✓ On driveline with torque limiting or overrunning devices, specify that the device be positioned to the end of the driveline by the implement.
- ✓ For implement connections which require bolts or set screws, select and/or supply hardware which minimizes protrusions. Information concerning these parameters may be found in all driveline manufacturer's catalogs.
- ✓ For tractors PTO shaft connections, specify a safety type yoke (twist or slide collar) to minimize protrusions.
- ✓ Provide a proper clearance zone for the operation of the driveline, to avoid damaging the shielding components.

**Some common areas of interference are:**

- Three point linkage.
- Extended or eye loop hitch pins.
- Hydraulic hoses.

**Guarding** – For hazards which cannot be eliminated effectively, guarding must be provided whenever feasible.

The PTO master shield, integral driveline shield, and implement input connection shield should provide an interactive guarding system.

- ✓ Provide instructions by labels or manuals. The implement should be used only with the tractor's PTO master shield in place.
- ✓ Specify and test an integral driveline shield with end cones which overlap, but not interfere with the PTO master shield or implement input connection shield.
- ✓ Provide an implement input connection shield to interact with the integral driveline shield to provide guarding of the shaft coupling and any torque limiting devices installed on the driveline.
- ✓ Check that all routine maintenance of the driveline can be done without removal of the shields.

# DRIVELINE SAFETY CHECKLIST

**Warnings and Instructions** – Provide warnings and instructions for hazards associated with the machine. Provide instructions for proper maintenance and repair.

- ✓ Provide labels on the unit to advise the user of proper hitch dimensions and maximum safe operating speed.
- ✓ Check that proper danger labels are supplied with the driveline concerning these parameters may be found in all driveline manufacturer's catalogs.
- ✓ Provide easy-to-understand instructions for proper driveline operation, maintenance, and repair in the operator's manual.
- ✓ Advise against the use of PTO adapters which may defeat the purpose of the tractor's master shield and adversely affect the performance of the driveline.
- ✓ Advise the user of locations of genuine original equipment spare parts.

Further information about driveline specifications and safety may be obtained from your driveline supplier and the following ASME standards and engineering practices:

- S203** – Rear power take-off for agricultural tractors
- S205** – Power take-off definitions and terminology for agricultural tractor
- S207** – Operating requirements for tractors and power take-off driven equipment implements
- S318** – Safety for agricultural equipment
- S331** – Implement power take-off driveline specifications
- S333** – Agricultural tractor auxiliary power take-off drives
- S350** – Safety alert symbol for agricultural equipment
- S441** – Safety signs
- S493** – Guarding for agricultural equipment
- EP363** – Technical publications for agricultural equipment

Other standards may apply for particular types of implements. All driveline manufacturers strive to produce a safe product. Drivelines, like most other components must be used properly, including the use of proper tractor master shields and implement input connection shields. Please contact us if you have any questions about your driveline applications.

# ASSEMBLY INSTRUCTIONS

- Your chipper will need to be set up prior to installation. It arrives in a steel crate that can be dismantled in minutes.
- The infeed bin and discharge chute are shipped with the unit and are located in the bottom of the steel crate.
- Visually inspect the infeed bin, and the fly wheel before attaching to tractor, and applying power to ensure that nothing is in the chipper head. If the chip deflector or any of the guards have been removed for shipping, be sure to replace them properly before use.
- The PTO (Driveline) is also shipped with the unit and is located in the bottom of the steel crate.
- When mounting, keep the chipper as close to the tractor as possible.
- **IMPORTANT** - Make sure that the PTO shaft is sized properly. See **PTO Shaft Sizing Instructions** on page 20 of this manual.
- While in use, keep the PTO shaft as straight as possible. Your PTO shaft will be more efficient and will have a longer life if it is as close to level as possible. No more than 25° degrees from level is acceptable.
- Do not operate the chipper without the chip deflectors, and or drive belt cover properly in place.
- Read and understand all assembly instructions prior to assembly.



# ASSEMBLY INSTRUCTIONS

## Assembly Instructions *(continued)*

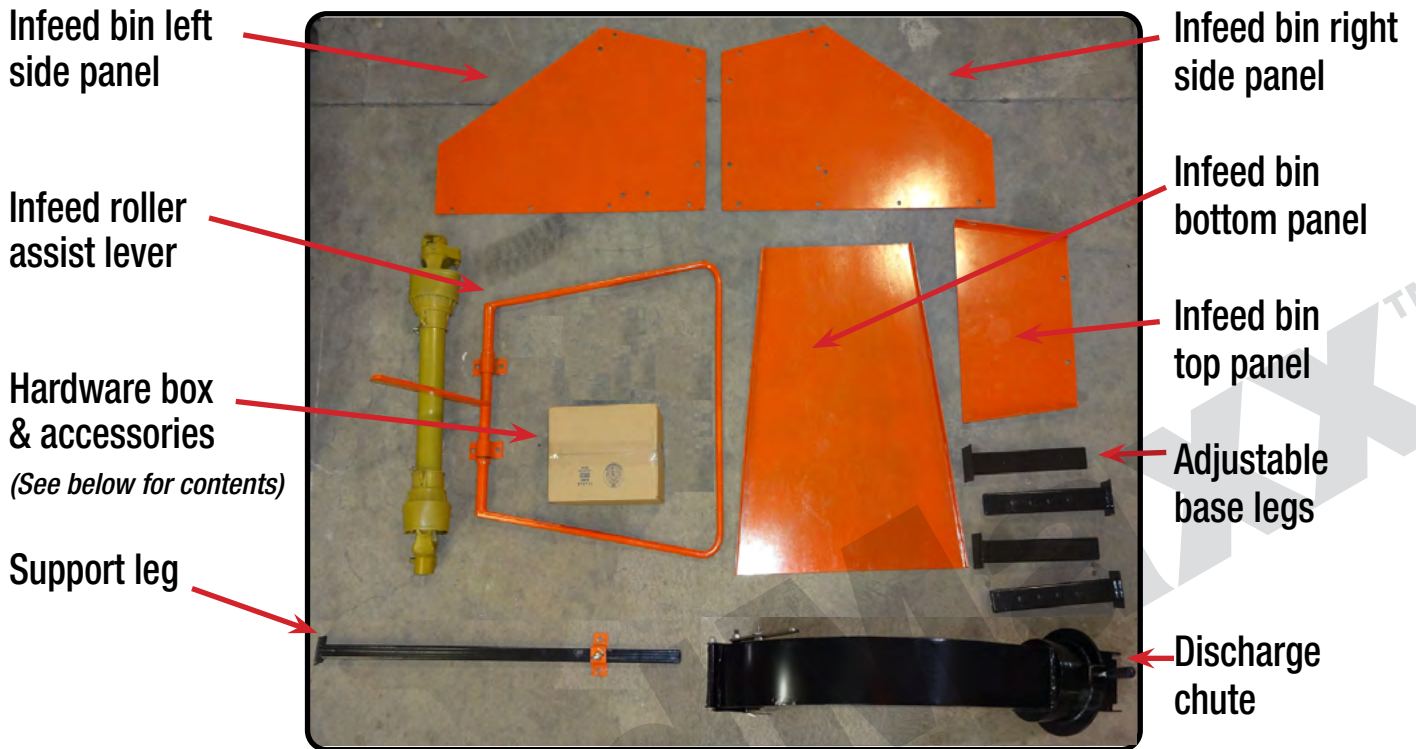

PTO Shield & Hardware



Skid Shoes



Safety Bar



Spring Removal Tool

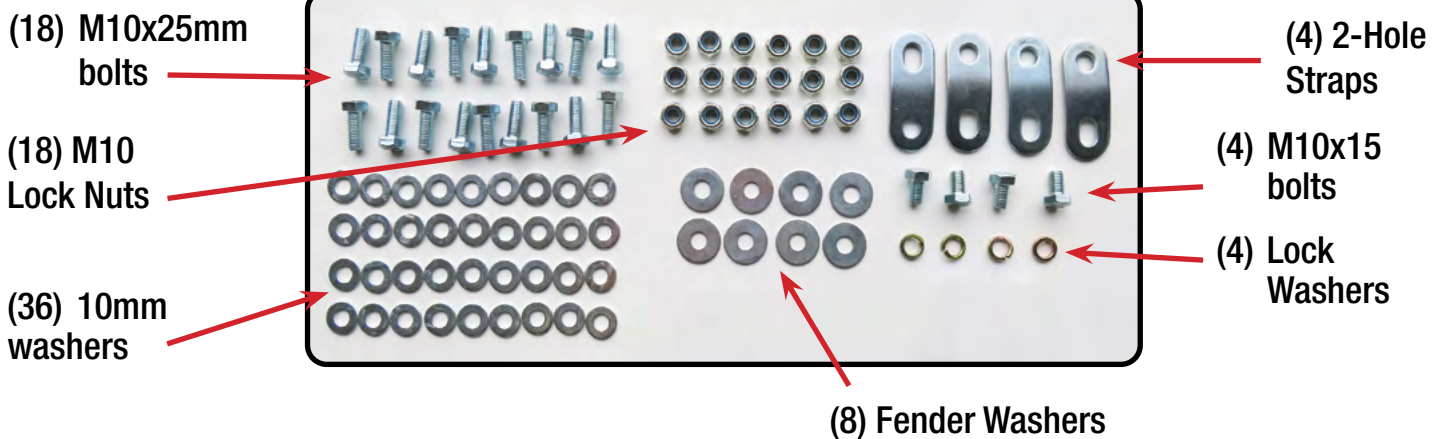

# ASSEMBLY INSTRUCTIONS

**Assembly Time - Approximately 2.5 Hours**

## Tools you will need:

- **13mm Wrench (same as 1/2")**
- **16mm Wrench (same as 5/8")**
- **Adjustable Wrench**
- **3/16 Allen Wrench**
- **6mm Allen Wrench**



- Remove the plastic wrapping and/or the cardboard from the crate and inspect the chipper for any obvious shipping damage.
- Remove and unwrap all the chipper components that are packaged in the crate.
- Remove the cardboard box from the in-feed bin. This box contains the user's manual, hardware packet, extra shear bolts, and any additional item that you may have purchased such as extra chipper knives.



- Open the hardware packet and organize the enclosed fasteners into separate piles. There is a picture of the hardware on page 11 of this manual that you can use as a guide to ensure that you use the correct hardware in the upcoming steps.
- Remove the four bolts that secure the top of the crate frame. Remove the top of the crate, and set it aside.
- Located on the bottom of the crate is a cross bar that secures the chipper to the frame. Loosen the two bolts that hold this bar in place, and drive the bar forward with a dead blow hammer.

# ASSEMBLY INSTRUCTIONS

## Assembly Instructions (continued)



**STEP 3**

- Locate the lift point on the top of the chipper. This is the balance point, and the only point the chipper should be lifted from.
- Using a chain or strap that is rated strong enough to lift the weight of the chipper, and the lift pin (not provided) lift the chipper out of the crate.
- If you do not have a front end loader, attach the three point hitch of your tractor to the chipper to lift the chipper out of the crate.



**STEP 4**

- Measure the distance from the PTO spline of your tractor to the ground. Write down this measurement here \_\_\_\_\_. You will need it for the next step.



**STEP 5**

- While the chipper is raised in the air, attach the four adjustable base legs so that when the chipper is on the ground, the spline of the chipper is slightly lower than the spline of your tractor.



**STEP 6**

- The shaft does not need to be perfectly horizontal, but it is recommended that the slope of the PTO shaft is no more than 25° degrees.
- Attach the skid shoe base plates as shown using the included carriage bolts and nuts. At this time, carefully lower the chipper to the ground, and remove the chain or strap.

# ASSEMBLY INSTRUCTIONS

## Assembly Instructions (continued)



**STEP 7**

- Attach the left panel of the in-feed bin using two of the 2-hole straps and two M10x25mm bolts. Straps will bend when tightened down. This panel can be identified by the two small holes on the bottom of the panel where the fasteners for the support leg attach.



**STEP 8**

- Attach the right side panel in the same manor.



**STEP 9**

- Attach the bottom panel of the in-feed bin, by first inserting the two M10x25 bolts through the side panels in the two holes closest to the feed roller. Do not tighten these bolts yet, and allow the panel to hang vertically.

Use Fender Washers Here



Outside mount (bolt, fender washer)

Inside mount (washer, lock nut)

View of proper assembly of in-feed bin using 2 hole straps. All other bolts are typically assembled as follows; bolt-washer-panel-washer-lock-nut

# ASSEMBLY INSTRUCTIONS

## Assembly Instructions *(continued)*



- Raise the bottom panel in place and insert the two M10x25 bolts the side panel in the two holes closest to the end of the panel.
- Install the remaining four M10x25 bolts in the remaining four holes in the lower panel.



- Before tightening the bolts, ensure that the lower panel is slightly higher than the in-feed bin. This will prevent material from hanging up where the two pieces join together.



- Attach the top panel of the in-feed bin by installing the four M10x25mm bolts in the two forward holes of the panel. Affix the safety bar stop to the top left of the in-feed bin.

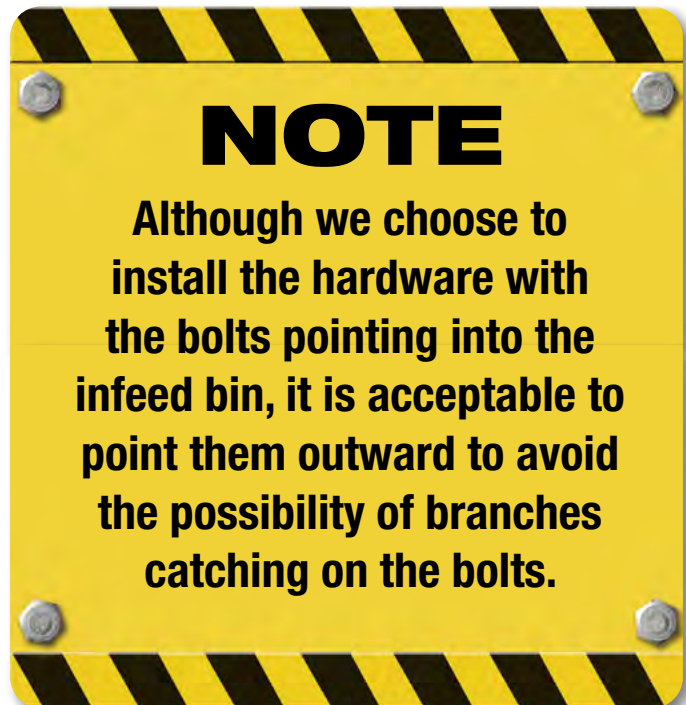



# ASSEMBLY INSTRUCTIONS

## Assembly Instructions *(continued)*



- Attach the support leg with two M10x25 bolts. Remember, the support leg should be in the down position during storage only. When the chipper is attached to the tractor, the support leg should be in the up position at all times.



- Attach the upper feed roller assist lever using four M10x25mm bolts.



- Fasten the chain from the upper feed roller assembly to the feed roller assist lever. The hardware for this is found located on the end of the chain.



- Connect the safety bar to the top side of the in-feed bin. First remove the bolt and nut on right arm of the safety bar. Hold the safety bar in place, so that you can read the word STOP, and the arrows point downward. Hook the bolt on the left arm of the safety bar through the hole on the top of the edge of the left in-feed panel.

# ASSEMBLY INSTRUCTIONS

## Assembly Instructions *(continued)*



- Align the hole on the right arm of the safety bar with the hole in the top edge of the right side panel, and reinstall the bolt and nut that you removed in the previous step.



- Thread a M10 locknut onto the bolt on either side, but do not tighten these nuts. This is a hinge point and the bar must move freely.



- Adjust the clutch cable length so that it is tight but not so tight that it starts to disengage the clutch. Attach the end of the clutch cable to the safety bar.



- Affix the discharge chute to the chipper using four M10x15mm bolts along with the four 10mm lock washers that were included in the hardware packet.

**Please check to make sure all nuts and bolts on machine are tightened after you complete the assembly, and before using the chipper for the first time. Although every effort has been made to ensure that all hardware has been tightened, it is a good idea for you to double check.**

# ASSEMBLY INSTRUCTIONS

## Assembly Instructions *(continued)*



**STEP 21**

**3-Point Hitch**

**Category 1 Quick Hitch**

- Connect the chipper to the 3-point hitch of your tractor [left], or if you have one, using your category I quick hitch [right].

**STEP 22** - See **PTO Shaft Sizing Instructions** on page 20 to size your PTO shaft to fit your tractor. **Failure to properly size your PTO shaft will result in damage to your chipper or tractor.**

**Damage resulting from improperly sized PTO shaft is not covered under warranty.**

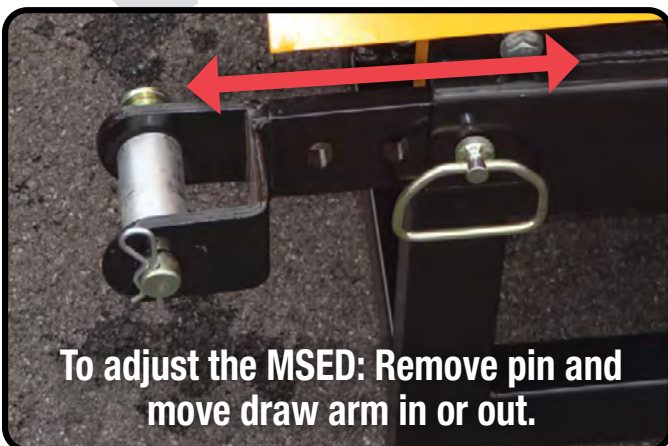

**To adjust the MSED: Remove pin and move draw arm in or out.**

- By extending the lower hitch brackets, you increase the distance between the tractor and the chipper, which lessens how much shaft you're required to cut.
- Now the shaft must be sized according to this measurement. Refer to the "PTO shaft cutting instructions" starting on page 20 of this manual to determine if you must size the shaft .

# ASSEMBLY INSTRUCTIONS

## Assembly Instructions (continued)



**STEP 23**

- After properly sizing the shaft, locate the three grease fittings on the shafts U-joints, and pump several shots of high quality grease into the fittings.

**NOTE:** Check to ensure that the zerk (grease) fittings are screwed in tight. Occasionally, dried paint may cover the end of the zerk fitting on the PTO shaft. Remove this by scraping the paint off with a knife prior to attempting to pump grease into these fittings.

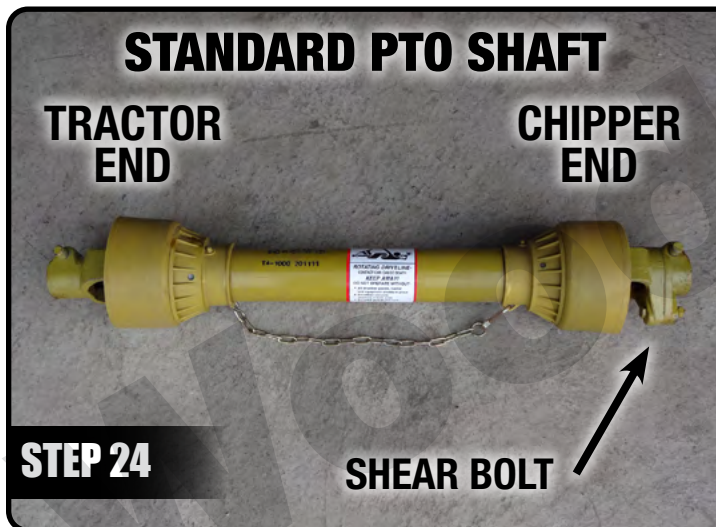

**STEP 24**

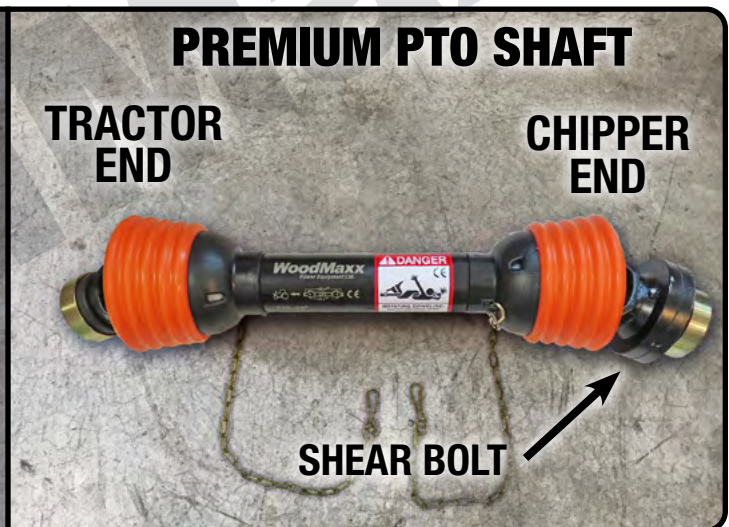

- Attach the PTO shaft from the tractor to the chipper. Notice that one end of the shaft has a shear bolt, this end should be attached to the chipper.

**Setup is now complete. You must read and understand all operation instructions before using the chipper.**

Prior to shipping the chipper to you, the following service has been done in our warehouse: the drive belts have been adjusted and tightened, the bearings on the chipper have been greased, USA made knives have been installed, adjusted, and the bolts were torqued to 40 ft. lbs.

# PTO SHAFT SIZING INSTRUCTIONS

## PTO Shaft Installation Instructions

(Refer to Figure 1)

- 1** Park the tractor on a level surface. Slowly adjust the tractor's 3-Point hitch until the tractor's output shaft is level with the implement's input shaft.
- 2** Place the gear selector in park, set the parking brake, shut the tractor off, and remove the switch key.
- 3** Block the implement to prevent it from going downward.
- 4** Slide the inner yoke (implement end) of PTO Shaft onto the input shaft. Secure the PTO Shaft with the yoke locking device.
- 5** Slide outer yoke (tractor end) of the PTO Shaft over the tractor output shaft. Secure the PTO Shaft with the yoke locking device.
- 6** If the PTO Shaft does not fit between the tractor and implement, skip to the instructions to "Shorten Driveline Length".
- 7** The PTO Shaft should now be moved back and forth to ensure that both ends are secured (to the tractor as well as the implement).
- 8** If your PTO Shaft is equipped with a chain on the shield, secure the chain to the tractor and / or implement. This will prevent the shield from spinning during operation.

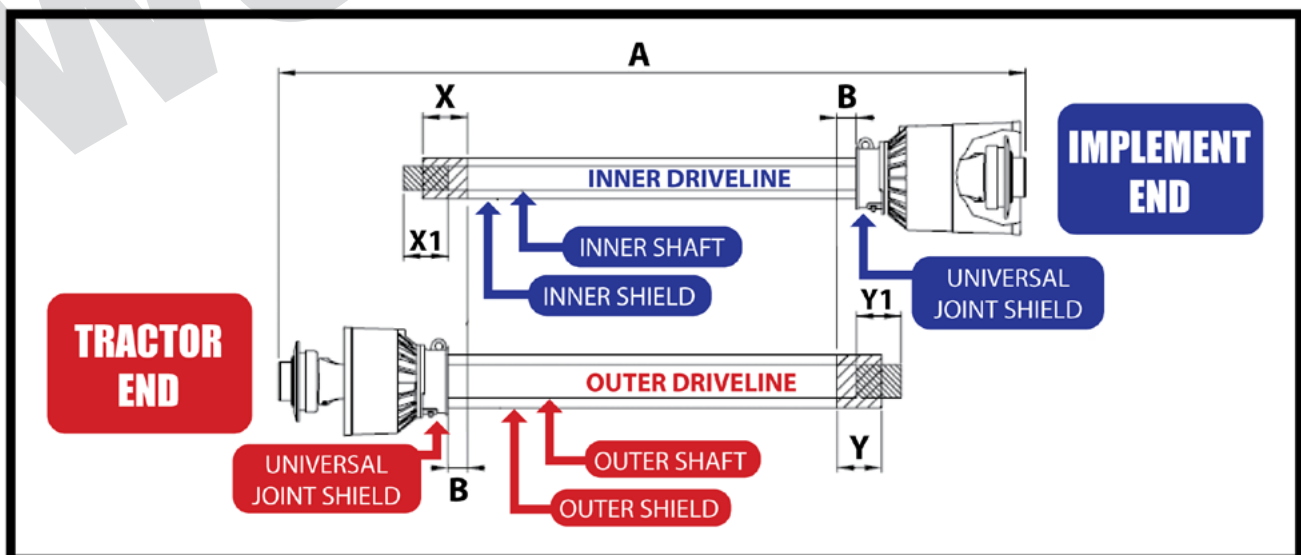

PTO Shaft Installation - Figure 1

# PTO SHAFT SIZING INSTRUCTIONS

## Shortening The PTO Shaft Length

(Refer to Figure 2)

- 1 Un-hook the PTO Shaft from tractor's output shaft and pull the outer and inner drivelines apart.
- 2 Reattach the outer driveline to the tractor's output shaft. Pull on the inner and outer drivelines to be sure they are properly secured.
- 3 Hold the inner and outer drivelines parallel to each other:
  - (3a) Measure 1" ("B" dimension) back from outer driveline universal joint shield and make a mark at this location on the inner driveline shield.
  - (3b) Measure 1" ("B" dimension) back from the inner driveline universal joint shield and make a mark at this location on the outer driveline shield.
- 4 Remove the drivelines from both the tractor and implement.
- 5 Measure from the end of inner shield to the scribed mark ("X" dimension). Cut off the inner shield at the mark. Cut the same amount off the inner shaft ("X1" dimension).
- 6 Measure from end of outer shield to the scribed mark ("Y" dimension). Cut off the outer shield at the mark. Cut the same amount off the outer shaft ("Y1" dimension).
- 7 Remove all burrs.
- 8 Check the PTO Shaft's **EXTENDED LENGTH** as described in the next step.

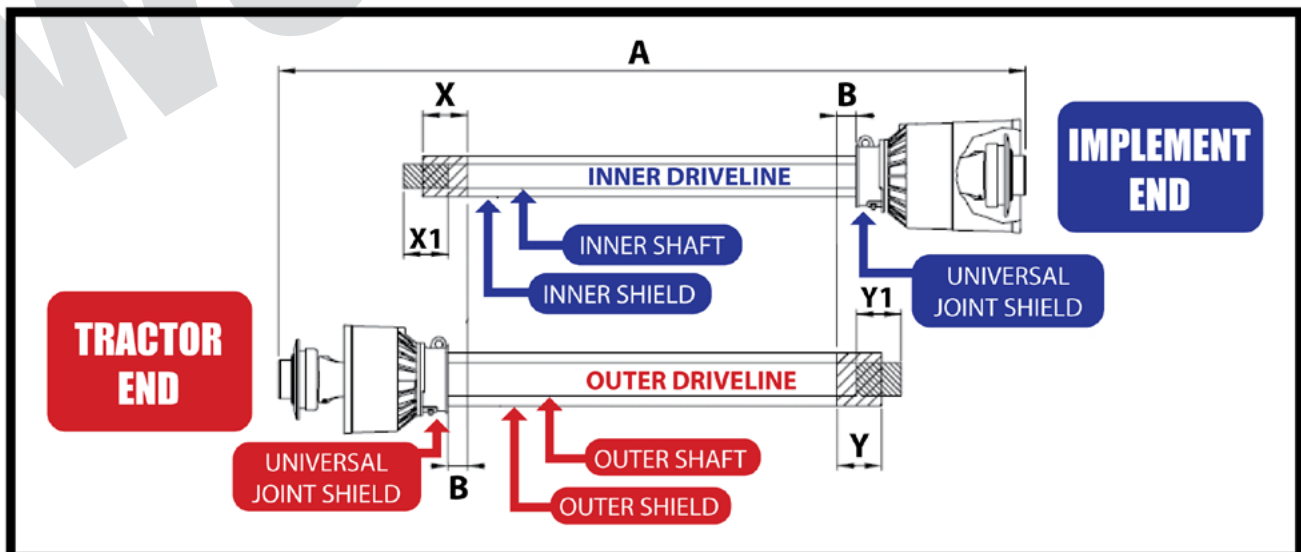

PTO Shaft Shortening - Figure 2

# PTO SHAFT SIZING INSTRUCTIONS

## Checking The PTO Shaft's Extended Length

(Refer to Figure 3)

Make sure the PTO Shaft's collapsible length is acceptable. The PTO Shaft maximum allowable length must, when fully extended, have a minimum overlap of the two driveline sides by not less than  $\frac{1}{3}$  the free length with both inner and outer drivelines being of equal length.

- 1 Apply multi-purpose grease to the inside of the "outer shaft" and reassemble the driveline.
- 2 Assemble the two drivelines together with  $\frac{1}{3}$  overlapping of inner and outer drivelines. Once assembled, measure and record the maximum allowable length shown below for future reference.

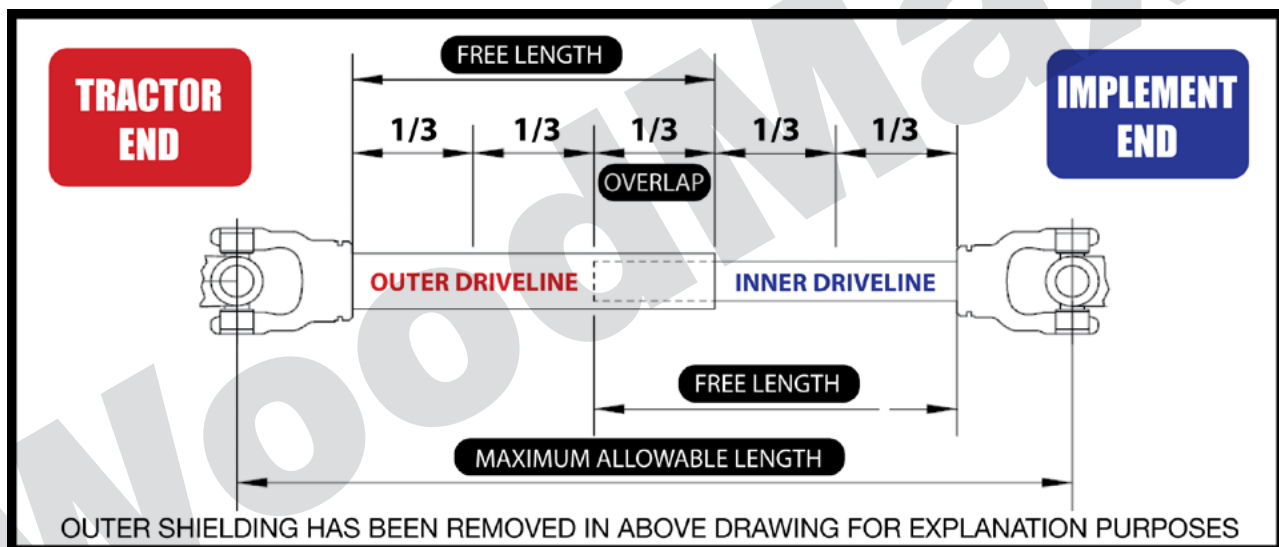

**PTO Shaft Maximum Extended Length - Figure 3**

- 3 Attach the inner driveline yoke to the implement's input shaft. Attach the outer driveline yoke to the tractor's output shaft.
- 4 Move the yoke ends of driveline back and forth to ensure they are secured to the tractor and implement shafts. Reattach any end that is loose.
- 5 Raise and lower the implement to find the maximum extended PTO Shaft length. Check to make certain that the PTO Shaft's overall length does not exceed the maximum recorded length in step 2.
- 6 If needed, set the tractor's 3-Point lift height to keep the PTO Shaft from exceeding the maximum allowable length.

# PTO SHAFT SIZING INSTRUCTIONS

## Checking The PTO Shaft's Interference

(Refer to Figure 4)

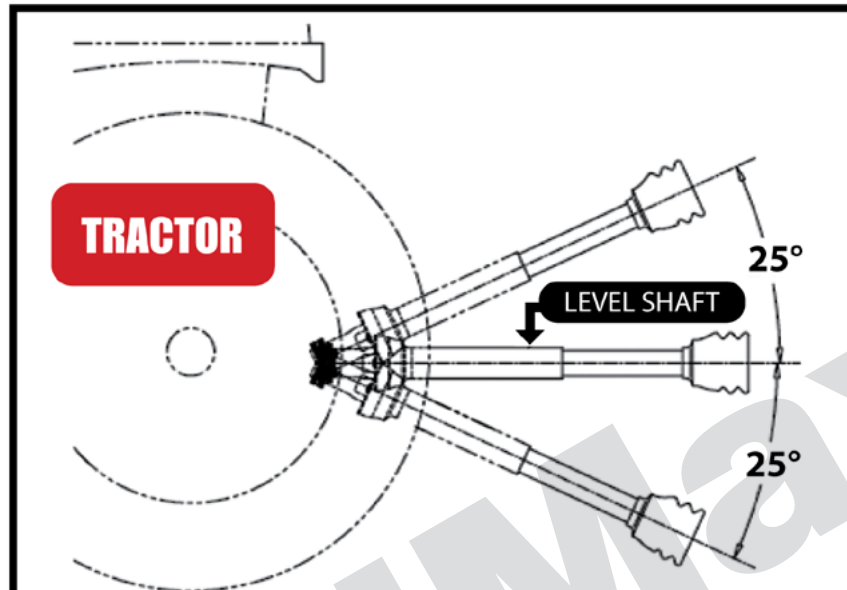

### Maximum PTO Shaft Movement During Operation - Figure 4

- 1 Slowly engage the tractor's hydraulic 3-Point hitch to lower the implement while checking for sufficient drawbar clearance. Move the drawbar ahead, aside, or remove if required.
- 2 If needed, set the tractor's 3-Point hitch lift height to keep the PTO Shaft from exceeding the maximum allowable length and 25° up or down.



**CAUTION:** Contact with the driveline while in use can result in serious injury or death. Any portion of the driveline while not shielded must be guarded by an interactive guarding system.

Any replacement guard must be one which is specified by the manufacturer. In short, do not remove any of the plastic safety covers on the driveline and insure that caution is used around this driveline.

No one should be in the driveline area when it is operating.



# GENERAL OPERATION

- The chipper is a flywheel-and-knife type of chipper, not a shredder. The knives actually chip the limbs they are fed into the head. The knives must be sharp to operate properly. Dirt, rocks, nails, or other foreign material will shorten knife life.
- Before operating the chipper, review the machine checklist. After visually inspecting the fly wheel and infeed bin to ensure there are no obstructions in the chipper head, start the tractor. Make sure the chipper is firmly on the ground and that the PTO shaft is no more than 25 degrees from level. The chipper must be resting on solid ground prior to operation. DO NOT operate while raised by 3 pt. hitch.
- Start the chipper slowly (idle) with the PTO engaged. Gradually increase engine RPM until the tractor PTO speed is 540 RPM (not 540 engine RPM) The chipper is designed to run at 540 RPM. Lower RPM can damage the chipper if material jams and stops the flywheel. The material will feed into the head more easily if you start the pieces with the large end first.
- The feed rollers will fold branches as they are pulled into the hopper. Occasionally, a limb fork may have to be cut to feed properly. If the material stops feeding, sometimes a little push on the long end of the limb will help.
- Remember to chip only clean material, or knife life will be shortened.
- Do not move the chipper while the flywheel is turning.
- Block the tractor wheels and set the parking brake while running the chipper.
- Watch the discharge chute while operating the unit, and if the chips stop flowing, stop feeding material into the unit by pushing forward on the hydraulic control valve handle located on the side of the infeed bin. This will stop the feed rollers from pulling material in.
- Most of the time this will be enough to clear the chips out of the unit. If the unit slows down noticeably, first shut off the PTO power, then the tractor. Unplug the flywheel by turning it backwards by hand with the discharge chute and the top section of the flywheel housing wrap off.
- Remove the chips from the top of the head. If this fails, remove the clean-out door, located in the lower part of the front side-plate of the chipper below the main shaft, and then work the chips out of the case.

## Protective Gear Required:

- Wrap around safety glasses
- Ear plugs
- Leather gloves
- Steel-toe work boots
- Heavy pants
- Long sleeved shirt

# GENERAL OPERATION

## General Operation *(continued)*

- Replace the clean-out door after all the chips are removed, be sure to use both the lock washers and flat washers.
- Do not operate the chipper without the chip deflector in place.
- Before stopping the chipper, be sure that all of the material is out of the chipper head and out of the in feed roller.
- All of the material in the chute must be gone or the unit could jam on a small piece of material. This can usually be cleared by turning the unit backwards by hand.
- Dull knives cause many problems such as: seeming lack of power, plugging of the discharge chute, rough cutting with more vibration than usual, feed roll shaft broken, main bearing house broken, main bearing working loose and the flywheel or knives hitting the case or bed knife, feed roller kicking out of gear, and not feeding.
- When sharpening the knives, be careful to keep angle A at a 37-39° angle. Knives cannot be rounded, or the knives will not pull the material into the head. (See **Flywheel Knife Sharpening Instructions** on page 30)
- The best way to tell if the knives need sharpening is to watch the chips coming out of the chip discharge. If they are long and straight, the knives are in need of service. Sometimes the knives feel sharp to the fingers, but may be worn or rounded. They will need to be sharpened.
- When operating the Wood Chipper, make sure you are standing in the safe OPERATOR ZONE. You must stay in the safe operating area at all times when the chipper drum is in motion. Never place any part of your body into a position that causes an unsafe operating condition.

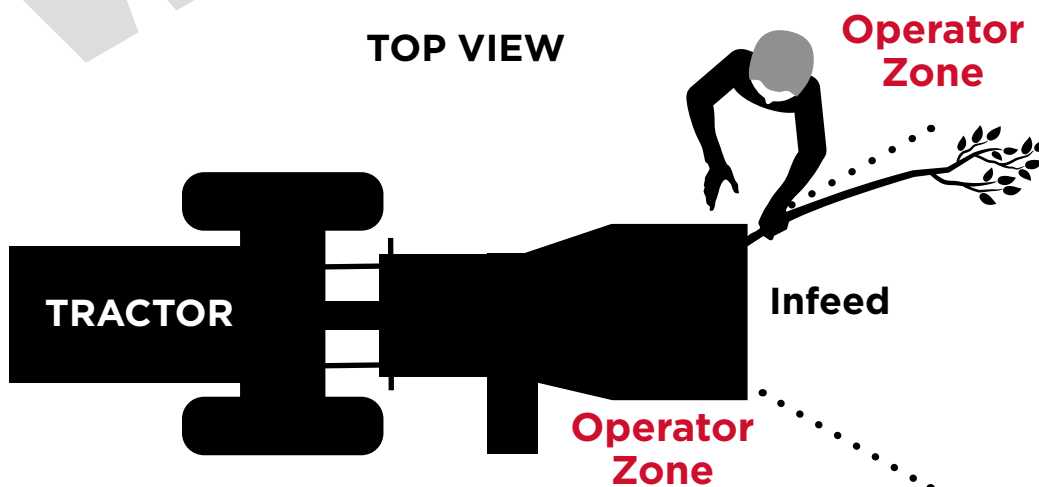

# LUBRICATION

- **BEARINGS** - All bearings have been factory greased. Refer to the **Bearing Lubrication Guide** below for recommended lubrication intervals.
- **PTO SHAFT** – grease the two grease zerks on the universals every 10 hours of use with a high quality multi-purpose grease.

## Bearing Lubrication Guide

There are many questions when it comes to greasing bearings. All WoodMaxx implements are now equipped with bearings that are factory greased so that 33% of the race is full of grease, this allows for operation at all speed ranges. In a clean, dry environment adding more grease to the bearing is not required for at least 500 hours of use. This is counter intuitive to many people that have older equipment and are used to pumping grease into the bearings daily. Modern high quality bearings are made from better steel alloys, provide higher tolerances, increased rubber seal compounds, and better quality lubricants. These recommendations are based on load, spindle speed, operating temperature, and environmental conditions. More grease is not better, rather is counterproductive and can cause the bearing to generate heat and lead to premature failure. You should never pump grease into a bearing until the seals push outward, this is a sign that too much grease is applied, and can deform the seal causing an entryway for contaminants. Follow the bearing lubrication schedule below for optimum performance and long bearing life.

## Bearing Lubrication Guide Based on Environmental Conditions

Machine stored and operated in clean, dry environment.	2-pump shots of grease after 500 hours	2" shaft or larger
	1-pump shot of grease after 500 hours	3/4"- 2" shaft
Machine stored and operated in dirty, dusty environment.	2-pump shot of grease after 250 hours	2"- shaft or larger
	1-pump shot of grease after 250 hours	3/4"- 2" shaft
Machine stored and operated in wet environment.	1-pump shot of grease after 50 hours	3/4"- shaft or larger

Wood chips alone do not constitute dust and can be considered a clean environment. Unless you are using the chipper in a wet and dirty environment, grease the bearings at 500 hour intervals.

# KNIFE CHANGING/ADJUSTING

## Tools you will need:

- Torque Wrench
- 16mm Wrench/Socket
- 17mm Socket
- 6mm Allen Wrench

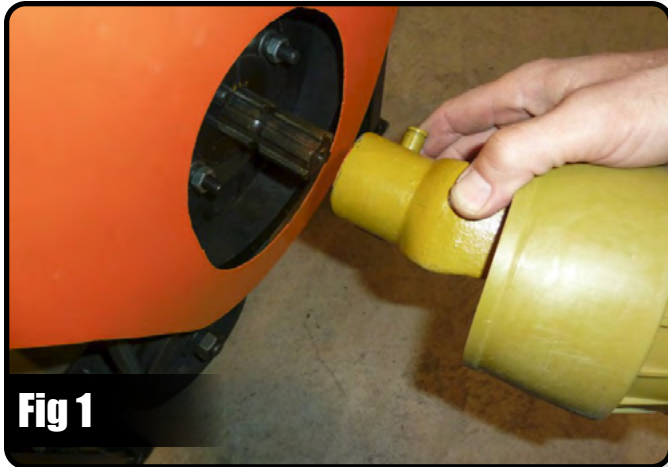

## STEPS:

- Detach PTO shaft from chipper. [Fig. 1]
- Remove shield that covers drive belts.
- Remove access panel on front and back of flywheel chamber to expose knife bolts and nuts. [Fig. 2]
- Clean and remove any debris that is impacted in knife bolt allen head socket using an awl or other pointed object. Take care to clean these out thoroughly to ensure allen wrench drive bit seats properly. If not, you may strip the heads out. Air blow gun is also helpful.
- Hold the head of the M10 cap screws with a 6mm allen wrench. From the back side of the flywheel, with a 17mm socket remove the nylon lock nuts. [Fig. 3]
- Remove the knives. Be careful not to drop the nuts or bolts into the flywheel chamber. If you do - See **Clearing An Object From The Flywheel Housing** on page 32.
- Replace knives with new or sharpened knives.
- Be sure there are no debris between the knife and flywheel.

# KNIFE CHANGING/ADJUSTING

## Knife Changing/Adjusting *(continued)*



**Fig 4**



**Fig 5**

### **STEPS:** *(continued)*

- Torque knife bolts by holding M10 cap screw heads with 6mm allen wrench, then with a 17mm socket and a torque wrench, tighten nylon lock nuts to 40 ft./lbs. **DO NOT over torque bolts or knife breakage may occur.** [Fig. 3] [Fig. 4]
- Replace access covers front and back.
- Remove both tension springs from infeed roller assembly.
- Raise and support infeed roller, a short piece of 2x4 works well for this. [Fig. 5]
- Clean and remove any debris that is impacted in knife bolt allen head socket using an awl or other pointed object. Take care to clean these out thoroughly to ensure allen wrench drive bit seats properly. If not, you may strip the heads out. Air blow gun is also helpful.
- Insert short end of 6mm allen wrench into socket, allowing long end to rest against the flywheel.
- Hold firm so wrench does not slip out of socket.

# KNIFE CHANGING/ADJUSTING

## Knife Changing/Adjusting *(continued)*

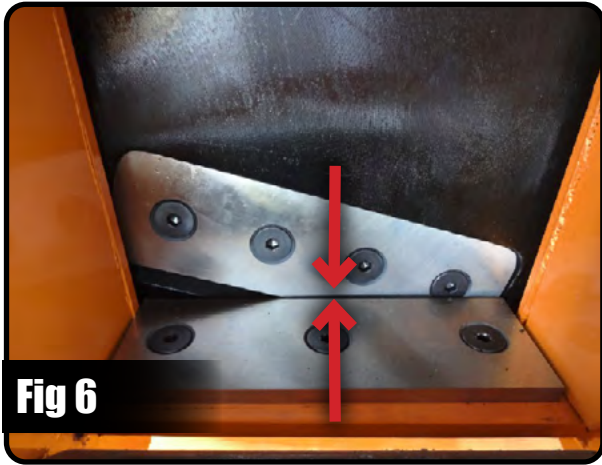

### STEPS: *(continued)*

- Using a 17mm socket, remove all three nuts from the bottom of the bed knife. Remove bed knife.
- Using an air gun, blow all debris from bed knifeseat. Be sure to clear any debris that could interfere with the bed knife seating properly on the frame.
- Replace bed knife, ensure that there is (0.0200" - 0.0300") of clearance between the flywheel knife and the bed knife. This is about the thickness of a credit card. [Fig. 6] (red arrow)
- Replace all three bolts/nuts and tighten to 40 ft./lbs. with a torque wrench. [Fig. 7] **DO NOT over torque bolts or knife breakage may occur.**
- Replace all shields and covers.
- Re-attach PTO shaft.

**NOTE:** Rotate the flywheel by hand to check to make sure that both flywheel knives clear the bed knife, without coming into contact with it, before applying PTO power to the chipper.

# FLYWHEEL KNIFE SHARPENING

## SHARPEN FLYWHEEL KNIVES

- To properly sharpen the knives, sharpen an angle A and keep the angle about 37°-39°, the same as a new set.
- Area B cannot be rounded, or the knives will not pull the material into the head.
- The best way to tell if the knives need sharpening is to watch the chips coming out of the chip discharge.
- If they are long and stringy, the knives need to be serviced. Sometimes, the knives feel sharp to the fingers, but may be worn or rounded in area B. These knives need to be sharpened.

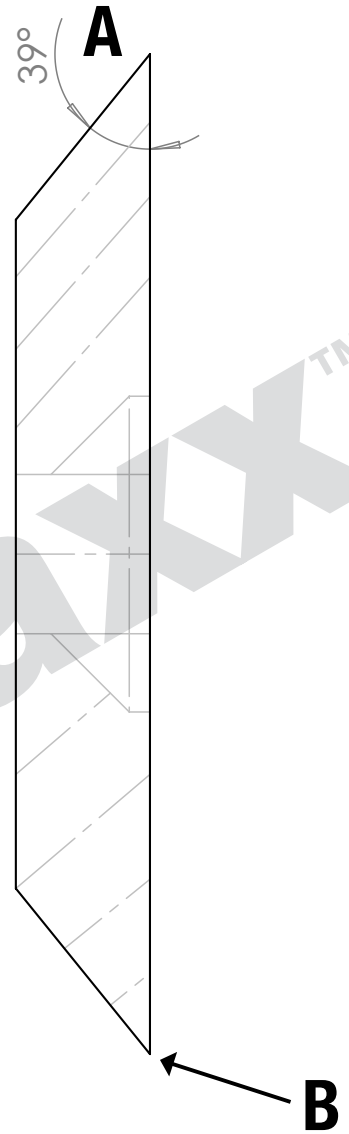

## KNIFE SHARPENING SERVICE

**NEW!** We now offer sharpening of any chipper knives purchased from **WoodMaxx™** for only \$15.00 per knife, plus return shipping. Please call for details and to take advantage of our service.

**NOTE:** we will evaluate each set of knives and determine on a case by case basis whether the knives can be sharpened or are beyond specifications.

CALL **855-966-3629** TO TAKE ADVANTAGE OF THIS OFFER

Only **\$15** Each

Plus Return Shipping



# FLYWHEEL KNIFE CARE

## How Long Will My Chipper Knives Last?

We get asked this question very often. WoodMaxx chippers are equipped with knives made from very high quality tool steel. That being said, all chipper knives will dull over time and will require sharpening or replacing at some point. If you treat the knives with the same respect as your chainsaw chain, you will get the longest life out of them. Follow the guidelines below to get the most out of your chipper knives.

✓ Be kind to your chipper knives. Although they are high quality tool steel they are not indestructible. All chippers will perform better when chipping fresh, green, clean limbs. The moisture in the limbs lubricates the knives and reduces friction. (Do not however attempt to chip rotten wood since it will plug your chipper)



✓ Although you can chip dry material, this will wear the knives at a faster rate than fresh green material. You must use your best judgment on this type of material. Try to avoid dirty limbs, since the dirt is abrasive and will reduce life expectancy.



✗ Always avoid material that may contain nails or foreign objects.

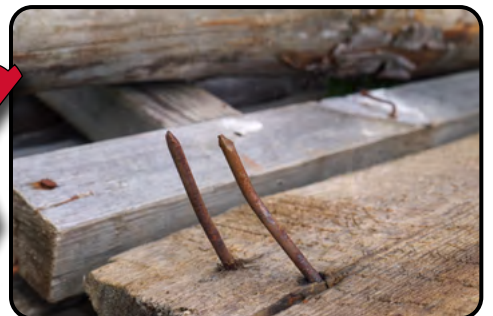

**Treat your chipper knives as you would a chain saw chain or the blades of a lawn mower. Be conscious of what you feed into the chipper, and you will get a lot of work out of a set of knives.**



# CLEARING FLYWHEEL HOUSING

## Tools you will need:

- 16mm Wrench

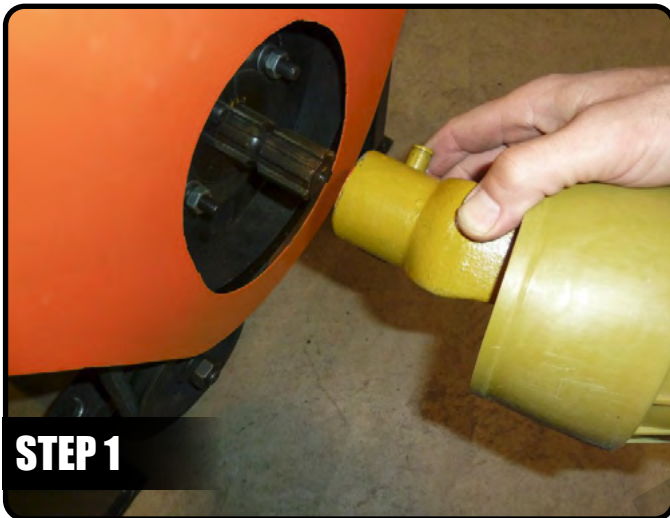

- Detach PTO shaft from chipper.



- Locate access door on bottom of flywheel housing. There is one on the front of the machine and one on the back of the machine on the very bottom of the flywheel housing.
- Using a 16mm wrench, remove the two bolts that secure the access cover.



- Remove cover.
- Locate/clear object from flywheel chamber.
- Replace access cover/bolts.
- Re-attach PTO shaft to chipper.
- Don't drop nut again.. 😊

# INFEED DRIVE AXLE POWER BELT

## Tools you will need:

- 18mm Wrench
- AX-32 V-Belt
- 16mm Wrench (same as 5/8")

## STEPS:

- Detach PTO shaft from chipper. [Fig. 1]
- Remove roller disengage bar cable. [Fig. 2]
- Remove shield that covers in feed drive axle.
- Using a 16mm wrench, loosen all 4 nuts that hold worm gear box to frame - but DO NOT remove
- Using a 18mm wrench, loosen jamb nut on belt adjustment screw. [Fig. 3]
- Unscrew belt adjustment screw until belt becomes loose. [Fig. 4]
- Install new belt.
- Tighten adjustment screw until belt becomes taught (so that when you squeeze the belt with one hand you can't touch belt to itself) [Fig. 5]
- When belt is taught, tighten both jamb nuts.
- Tighten all 4 nuts that hold worm gear box to frame.
- Reattach cover & roller disengage bar cable
- Reattach PTO shaft.



Fig. 1



Fig. 2

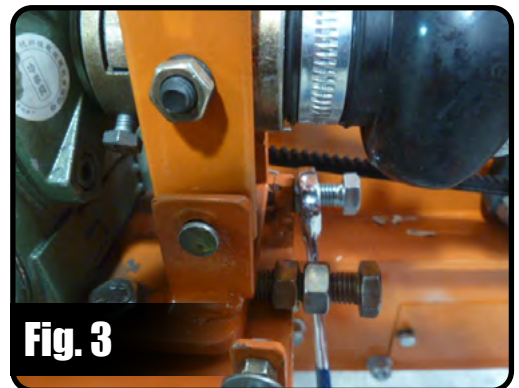

Fig. 3



Fig. 4



Fig. 5

# CHANGING/ADJUSTING DRIVE BELT

## Tools you will need:

- 18mm Wrench
- (5) BX-46 Belts
- 18mm Socket
- Straight Edge

## STEPS:

- Detach PTO shaft from chipper. [Fig. 1]
- Remove drive belt cover.
- Loosen 4 bolts that support the lower jack shaft assembly. (18mm) [Fig. 2]
- Loosen 4 adjustment bolts until jack shaft assembly and belts become loose. (18mm) [Fig. 3] [Fig. 4]
- Remove/replace belts.
- Tighten 4 adjustment bolts until belts are tight and pulleys are parallel and in line with each other. (+/- 1/8" is acceptable) [Fig. 5]
- Attach drive belt cover.
- Re-attach PTO shaft.

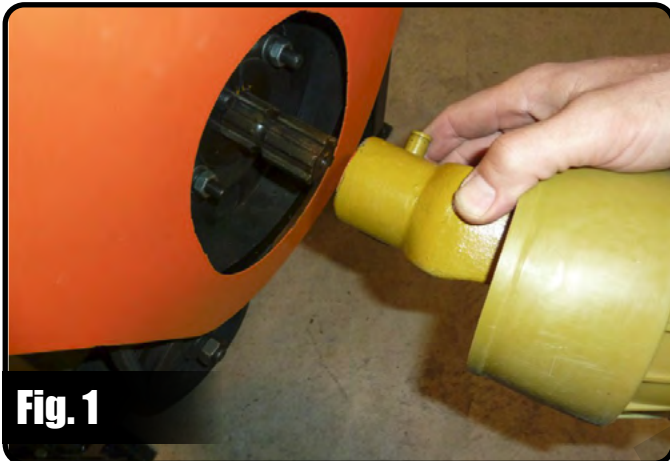

# MAINTAIN INFEED DRIVE AXLE

## Tools you will need:

- 4mm Allen Wrench
- Mineral spirits solvent, grease
- Flat Head Screwdriver
- Way oil, heavy viscosity slide way lubricant.  
(Chainsaw bar oil works well)

## STEPS:

- Detach PTO shaft from chipper. [Fig. 1]
- Remove in-feed roller disengage bar cable. [Fig. 2]
- Remove shield that covers axle.
- Remove each side of drive axle. (4mm Allen Wrench) [Fig. 3]
- Clean drive axle with solvent and a brush. [Fig. 4]
- Apply liberal amounts of grease to the clutch assembly. [Fig. 5]
- Install drive axle.
- Apply a liberal amount of way oil, (chainsaw bar oil) onto shaft, and universal joint. Be careful not to get oil on the belts/pulleys. This type of oil has properties that allows the oil to stick to the metal and have superior lubrication to prolong the shaft life, and is ideally suited for this application. [Fig. 4]
- Reattach shield/cable.

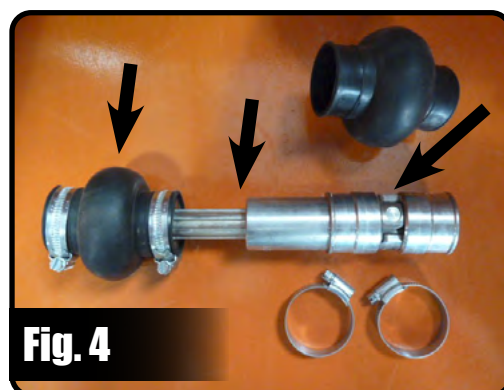

# MAINTENANCE / STORAGE

## Regular Maintenance Checklist

Before Each Use

Every 10 Hours

Every 20 Hours

Every 100 Hours

PROCEDURE	SERVICE DATES												
Check/Tighten Fasteners	✓	✓											
Grease Bearings	See <b>Bearing Lubrication Guide</b> on page 26 of this manual												
Check Connection to Tractor	✓												

## PTO SHAFT SHEAR BOLT REPLACEMENT

### Standard PTO Shaft



Grade 5 – Size 5/16 x 18 x 2<sup>1</sup>/<sub>4</sub>" - Part # SHRB-IM  
Available at any hardware store, on our website at [WoodMaxx.com](http://WoodMaxx.com) or call 1-855-966-3629.

### Premium PTO Shaft



Available only through the website at [WoodMaxx.com](http://WoodMaxx.com) or call 1-855-966-3629 to order - Part # SHRB-PR

## Storage

At the end of the working season or when the wood chipper will not be used for a long period, it is a good practice to clean off any dirt or dust that may have accumulated on the wood chipper and any of the moving parts.

- Detach and store the wood chipper in an area where children normally do not play. Secure by using blocks and supports.
- Clean as necessary.
- Check knives for wear and sharpen or replace if necessary.
- Inspect wood chipper for loose, damaged or worn parts and adjust or replace as needed.
- Check all safety labels. Replace any worn or damaged labels.
- Store unit inside if possible for longer life. Alternatively, cover with a tarp to reduce exposure and prevent weather damage.
- Repaint parts where paint is worn or scratched to prevent rust.
- Apply an anti-rust lubricant to the knives to prevent rust. 3-in-1 or WD-40 spray oil is a good choice.

# TORQUE SPECIFICATIONS

## Torque Specifications

The tables shown below give the correct torque values for various bolts and cap screws. Tighten all bolts to the torques specified unless otherwise noted. Check tightness of bolts periodically, using bolt torque chart as a guide. Replace hardware with the same length and grade of bolt.

Torque Values Chart for Common Bolt Sizes													
Bolt Size (Inches)	Bolt Head Identification						Bolt Size (Metric)	Bolt Head Identification					
	Grade 2		Grade 5		Grade 8			Class 5.8		Class 8.8		Class 10.9	
in-tpi <sup>1</sup>	N-m <sup>2</sup>	ft-lb <sup>3</sup>	N-m	ft-lb	N-m	ft-lb	mm x pitch <sup>4</sup>	N-m	ft-lb	N-m	ft-lb	N-m	ft-lb
1/4" - 20	7.4	5.6	11	8	16	12	M 5 X 0.8	4	3	6	5	9	7
1/4" - 28	8.5	6	13	10	18	14	M 6 X 1	7	5	11	8	15	11
5/16" - 18	15	11	24	17	33	25	M 8 X 1.25	17	12	26	19	36	27
5/16" - 24	17	13	26	19	37	27	M 8 X 1	18	13	28	21	39	29
3/8" - 16	27	20	42	31	59	44	M10 X 1.5	33	24	52	39	72	53
3/8" - 24	31	22	47	35	67	49	M10 X 0.75	39	29	61	45	85	62
7/16" - 14	43	32	67	49	95	70	M12 X 1.75	58	42	91	67	125	93
7/16" - 20	49	36	75	55	105	78	M12 X 1.5	60	44	95	70	130	97
1/2" - 13	66	49	105	76	145	105	M12 X 1	90	66	105	77	145	105
1/2" - 20	75	55	115	85	165	120	M14 X 2	92	68	145	105	200	150
9/16" - 12	95	70	150	110	210	155	M14 X 1.5	99	73	155	115	215	160
9/16" - 18	105	79	165	120	235	170	M16 X 2	145	105	225	165	315	230
5/8" - 11	130	97	205	150	285	210	M16 X 1.5	155	115	240	180	335	245
5/8" - 18	150	110	230	170	325	240	M18 X 2.5	195	145	310	230	405	300
3/4" - 10	235	170	360	265	510	375	M18 X 1.5	220	165	350	260	485	355
3/4" - 16	260	190	405	295	570	420	M20 X 2.5	280	205	440	325	610	450
7/8" - 9	225	165	585	430	820	605	M20 X 1.5	310	230	650	480	900	665
7/8" - 14	250	185	640	475	905	670	M24 X 3	480	355	760	560	1050	780
1" - 8	340	250	875	645	1230	910	M24 X 2	525	390	830	610	1150	845
1" - 12	370	275	955	705	1350	995	M30 X 3.5	960	705	1510	1120	2100	1550
1-1/8" - 7	480	355	1080	795	1750	1290	M30 X 2	1060	785	1680	1240	2320	1710
1 1/8" - 12	540	395	1210	890	1960	1440	M36 X 3.5	1730	1270	2650	1950	3660	2700
1 1/4" - 7	680	500	1520	1120	2460	1820	M36 X 2	1880	1380	2960	2190	4100	3220
1 1/4" - 12	750	555	1680	1240	2730	2010							
1 3/8" - 6	890	655	1990	1470	3230	2380							
1 3/8" - 12	1010	745	2270	1670	3680	2710							
1 1/2" - 6	1180	870	2640	1950	4290	3160							
1 1/2" - 12	1330	980	2970	2190	4820	3560							

<sup>1</sup> in-tpi = nominal thread diameter in inches-threads per inch  
<sup>2</sup> N·m = newton-meters  
<sup>3</sup> ft-lb = foot pounds  
<sup>4</sup> mm x pitch = nominal thread diameter in millimeters x thread pitch

Torque tolerance + 0%, -15% of torquing values. Unless otherwise specified use torque values listed above.

Torque figures indicated above are valid for non-greased or non-oiled threads and heads otherwise specified. Therefore, do not grease or oil bolts or cap screws unless otherwise specified in this manual. When using locking elements, increase torque values by 5%.

# SAFETY LABELS

## Safety Labels

Your wood chipper comes equipped with all safety labels in place. They were designed to help you safely operate your implement. Read and follow their directions.

- Keep all safety labels clean and legible.
- Replace all damaged or missing labels. To order new labels call **WoodMaxx Power Equipment Ltd. at 855-966-3629.**
- Some new equipment installed during repair requires safety labels to be affixed to the replaced component as specified by WoodMaxx. When ordering new components make sure the correct safety labels are included in the request.



# SAFETY LABELS



WM-8M-PULL



WM-DNG-BLADE



WM-DNG-THROWN



WM-DNG-DRIVE



WM-CTN-540

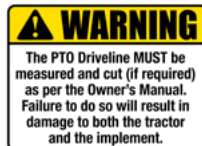
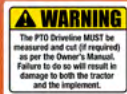

WM-WRN-PTO



# TROUBLESHOOTING

PROBLEM	POSSIBLE CAUSE	SOLUTION
<b>Flywheel head slows but tractor does not</b>	<ul style="list-style-type: none"> <li>• Main drive belts are slipping.</li> </ul>	<ul style="list-style-type: none"> <li>• Tighten or replace if necessary.</li> </ul>
	<ul style="list-style-type: none"> <li>• Flywheel knives are dull.</li> </ul>	<ul style="list-style-type: none"> <li>• Sharpen or replace knives.</li> </ul>
<b>Feed roll clutch kicking in and out of gear excessively</b>	<ul style="list-style-type: none"> <li>• Flywheel knives are dull.</li> </ul>	<ul style="list-style-type: none"> <li>• Sharpen or replace knives.</li> </ul>
	<ul style="list-style-type: none"> <li>• Material jammed in chute.</li> </ul>	<ul style="list-style-type: none"> <li>• Release feed roll clutch and remove material by pulling it out of the chute. Trim forks and feed in to the chute.</li> </ul>
<b>Not chipping clean or chip deflector plugging</b>	<ul style="list-style-type: none"> <li>• Flywheel knives are dull.</li> </ul>	<ul style="list-style-type: none"> <li>• Sharpen or replace knives.</li> </ul>
	<ul style="list-style-type: none"> <li>• Chipper head is turning too slowly.</li> </ul>	<ul style="list-style-type: none"> <li>• Check that PTO speed is at 540 RPM.</li> </ul>
	<ul style="list-style-type: none"> <li>• Bed knife (anvil) rounded off.</li> </ul>	<ul style="list-style-type: none"> <li>• Reverse or sharpen.</li> </ul>
<b>Unit won't feed limbs properly</b>	<ul style="list-style-type: none"> <li>• Not enough down pressure on limbs.</li> </ul>	<ul style="list-style-type: none"> <li>• Adjust eyebolts to increase spring tension.</li> </ul>
	<ul style="list-style-type: none"> <li>• Fork in material is too wide.</li> </ul>	<ul style="list-style-type: none"> <li>• Remove and trim.</li> </ul>
	<ul style="list-style-type: none"> <li>• Feed roll tension springs stretched wide.</li> </ul>	<ul style="list-style-type: none"> <li>• Replace springs.</li> </ul>
	<ul style="list-style-type: none"> <li>• Feed roll gear box belt loose.</li> </ul>	<ul style="list-style-type: none"> <li>• Tighten or replace if necessary.</li> </ul>

# PARTS & DIAGRAMS

## WM-8M Mechanical Wood Chipper Parts Diagram

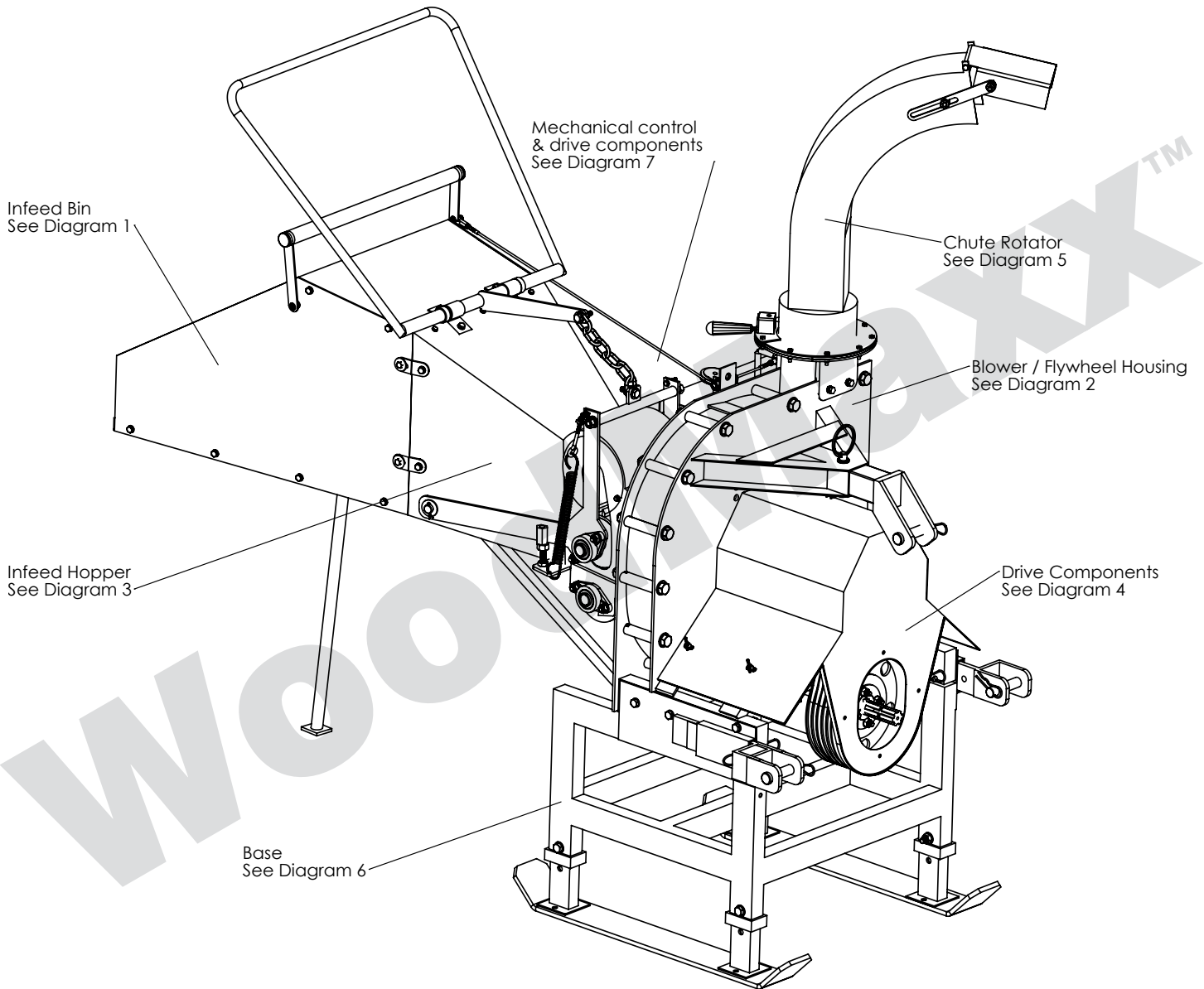

# PARTS & DIAGRAMS

## 8M Mechanical Wood Chipper Diagram 1 – Infeed Bin

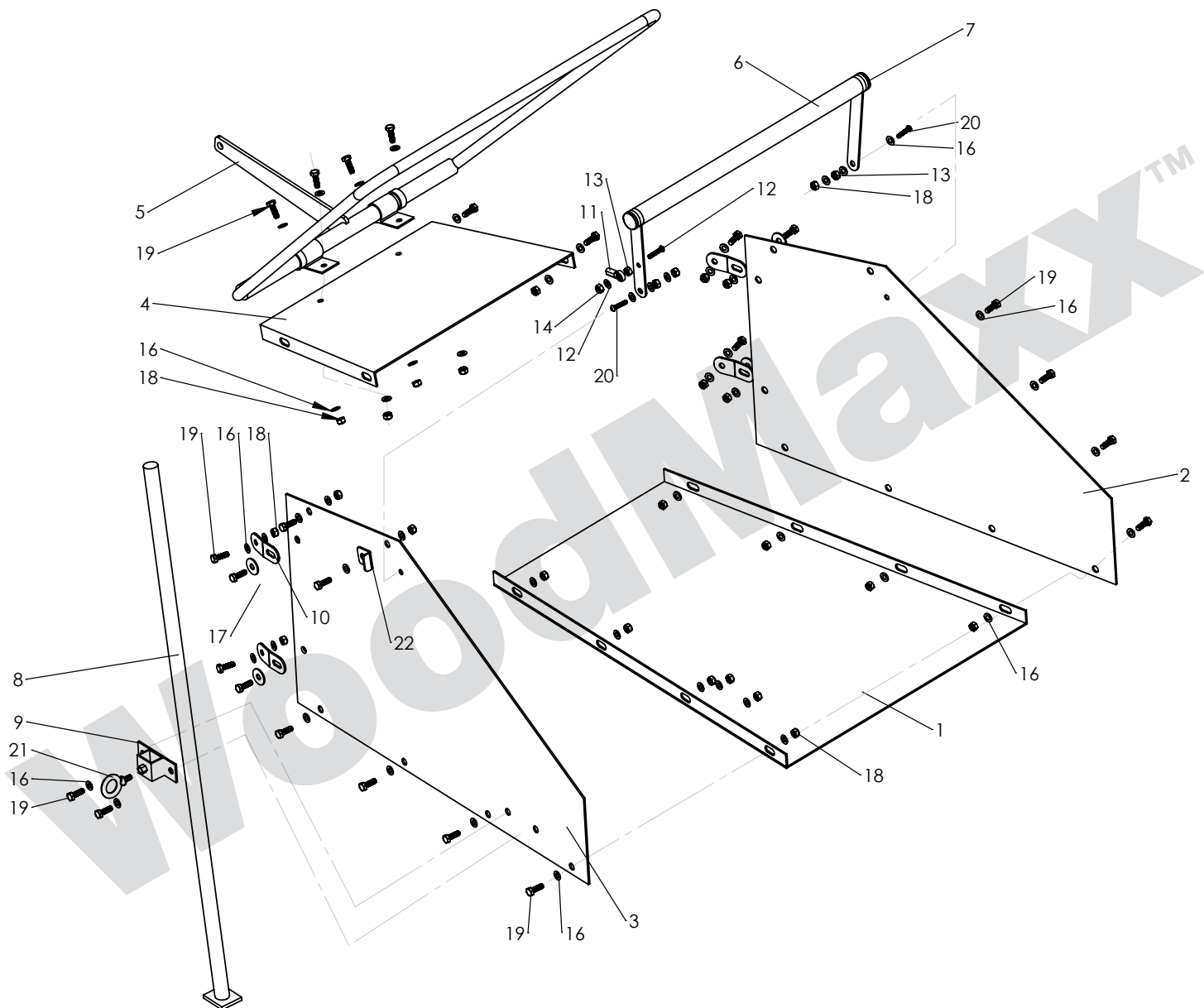

# PARTS & DIAGRAMS

## WM-8M Wood Chipper - Infeed Bin - Diagram 1 - Parts List

POS #	PART #	PART DESCRIPTION	QTY
1	WM8-1-1	In-feed bin (bottom section)	1
2	WM8M-1-2	In-feed bin (right side panel)	1
3	WM8M-1-3	In-feed bin (left side panel)	1
4	WM8-1-4	In-feed bin (top section)	1
5	WM8-1-5	In-feed roller lift assist bar	1
6	WM8M-1-6	Safety bar	1
7	WM8-1-7	1-1/4" plastic plug	2
8	WM8-1-8	Support leg	1
9	WM8-1-9	Support leg bracket	1
10	WM8-1-10	Side panel attachment bracket	1
11	See Dia-7 #15	Ball joint, cable control	1
12	M8 FW	M8 Flat washer zinc	1
13	M8x1.25 NUT	M8x1.25 Hex nut zinc	1
14	M8x1.25 NYLOCK	M8X1.25 Nylon lock nut	1
15	M8x1.25x30 HHCS	M8x1.25x30 Hex head cap screw GR8.8 zinc	4
16	M10 FW	M10 Flat washer zinc	2
17	M10 FEN. W	M10x25 Fender washer	4
18	M10x1.5 NYLOCK	M10-1.5 Nylon lock nut	12
19	M10x1.5x25 HHCS	M10x1.5x25 Hex head cap screw GR 8.8	8
20	M10x1.5x40 HHCS	M10x1.5x40 Hex head cap screw GR 8.8	2
21	M10x1.5x15 EYE	M10x1.5x15 EYE bolt (cast steel)	1
22	M8-1-22	Safety bar stop tab	1

All of the hardware on this machine follows the ISO 262 Specification Guidelines (Coarse Pitch) unless otherwise noted:

Hardware Size:	M5	M6	M8	M10	M12	M14	M16
Pitch:	.8	1.0	1.25	1.5	1.75	2.0	2.0

All grease fittings are M6 x 1.0 on the chipper, M8 x 1.0 on the PTO shaft.

# PARTS & DIAGRAMS

## WM-8M Wood Chipper – Diagram 2 – Blower/Flywheel Housing

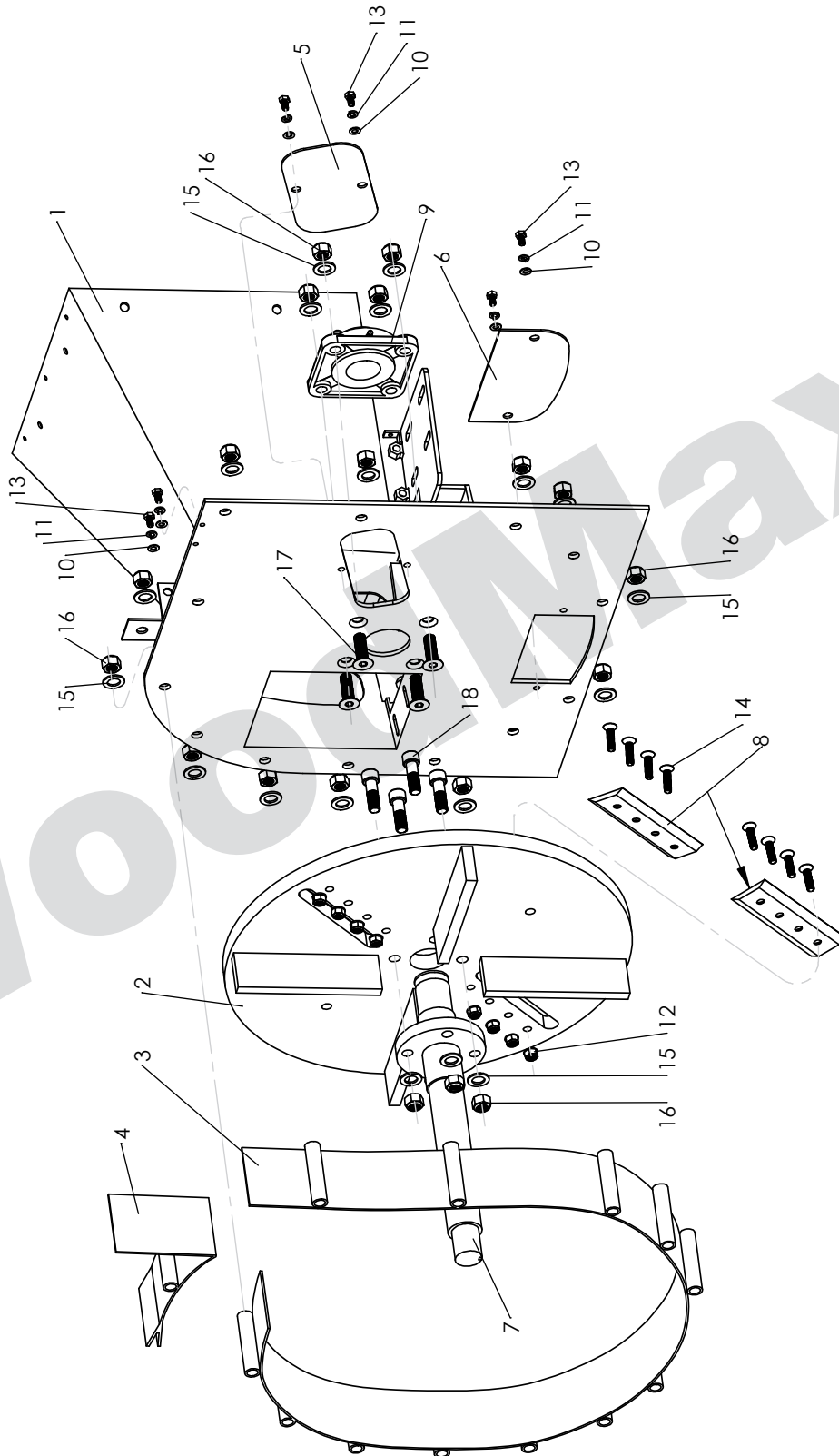

# PARTS & DIAGRAMS

## WM-8M Wood Chipper – Diagram 2 – Blower/Flywheel Housing – Parts List

POS #	PART #	PART DESCRIPTION	QTY
1	WM8M-2-1	Flywheel housing (In-feed side)	1
2	WM8-2-2	Flywheel weldment	1
3	WM8-2-3	Flywheel housing (center section)	1
4	WM8-2-4	Top access panel (flywheel housing)	1
5	WM8-2-5	Chipper knife access panel	1
6	WM8-2-6	Flywheel housing clean out panel (bottom)	1
7	WM8M-2-7	Flywheel spindle shaft	1
8	400078	MX/WM/TM Fly wheel knife	2
9	UCF210-50	Flange bearing 4 bolt (UCF210-50mm 4 hole flange)	1
10	M10 FW	M10 Flat washer zinc	2
11	M10 SLW	M10 Med split lock washer zinc	2
12	M10x1.5 NYLOCK	M10-1.5 Nylon lock nut	8
13	M10x1.5x16 HHCS	M10x1.5x16 Hex head cap screw GR 8.8	4
14	M10x1.50x40 FHCS FT	M10x1.50x40 Flat socket cap screw GR 10.9	8
15	M16 FW	M16 Flat washer zinc	20
16	M16x2.0 NYLOCK	M16x2.0 Nylon lock nut zinc	4
17	M16x2.0x50 FHCS FT	M16x2.0x50 Flat head cap screw GR 8.8 (full thread)	4
18	M16x2.0x60 HHCS	M16x2.0x60 Hex head cap screw zinc	4

# PARTS & DIAGRAMS

## WM-8M Mechanical Wood Chipper Diagram 3 – Infeed Hopper

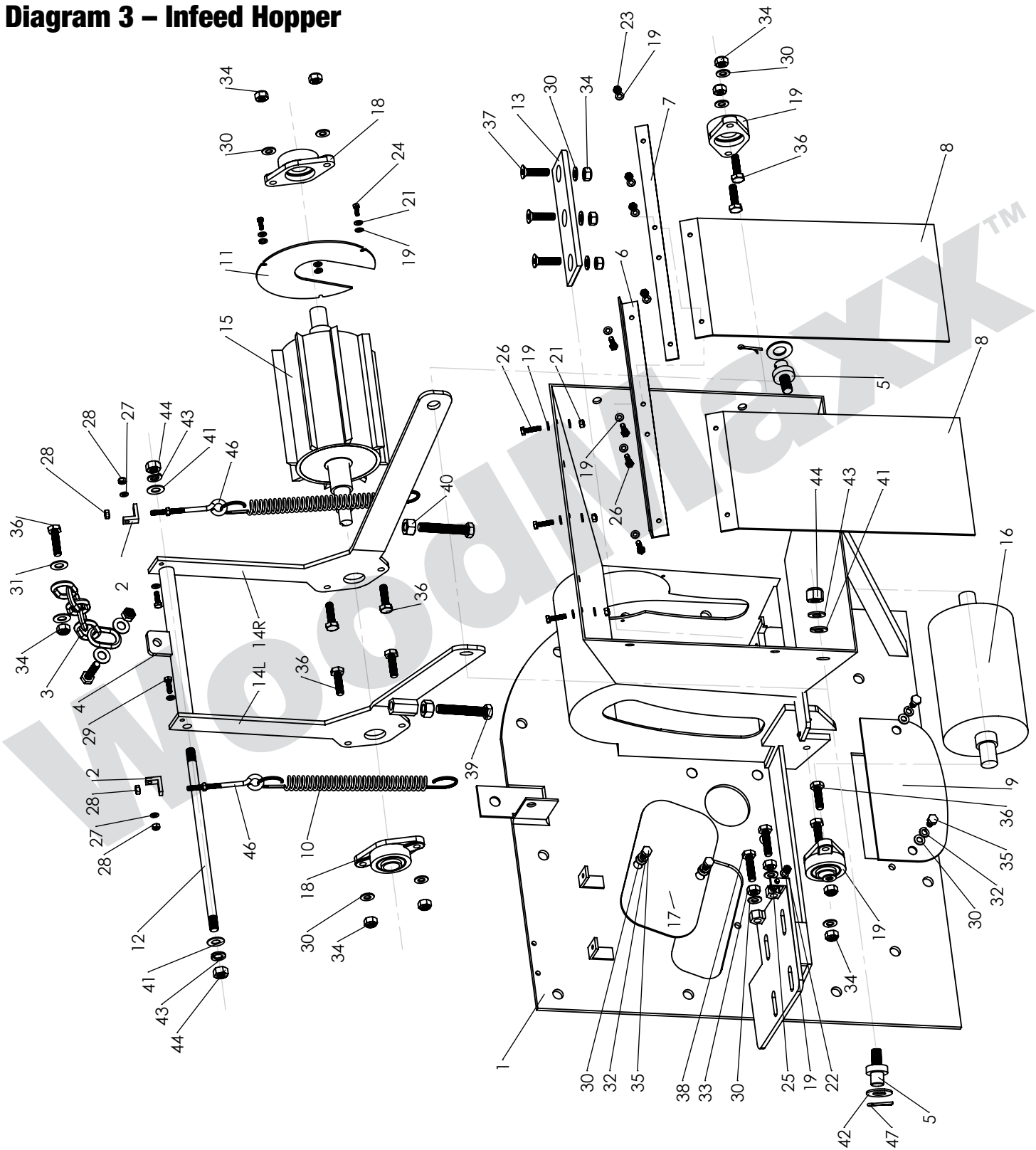

# PARTS & DIAGRAMS

## WM-8M Wood Chipper - Diagram 3 – Infeed Hopper – Parts List

POS #	PART #	PART DESCRIPTION	QTY
1	See Dia-2 #1	Flywheel housing half (In-feed side)	1
2	WM8-3-2	Angle bracket for eye bolt (spring)	2
3	WM8-3-3	Chain, In-feed roller lift assist bar	1
4	WM8-3-4	Roller lift cross tube	1
5	WM8-3-5	Pivot pin, in-feed roller arm bracket (M14)	2
6	WM8-3-6	Chip deflector mount bracket	1
7	WM8-3-7	Chip deflector mount plate	1
8	WM8-3-8	Vinyl chip deflector	2
9	See Dia-2 #6	Flywheel housing clean out panel (bottom)	1
10	WM8-3-10	Roller tension spring	2
11	WM8-3-11	Cover roller access	1
12	WM8-3-12	M14x1.5 threaded rod, In-feed roller lift arm tube (14mm x 324mm (12-3/4"))	1
13	USA-WM-BB	Bed knife	1
14L	WM8-3-14	Roller Lift arm bracket ( left side )	1
14R	WM8M-3-14R	Roller Lift arm bracket ( Right side )	1
15	WM8M-3-15	In-feed roller (upper)	1
16	WM8M-3-16	In-feed roller (lower)	1
17	See Dia-2 #5	Chipper knife access panel	1
18	UCFL204-20	In-feed roller bearing (F204-20mm 2-hole flange)	2
19	M6 FW	M6 Flat washer zinc	3
21	M6 SLW	M6 Med split lock washer zinc	3
22	M6x1.0 NUT	M6x1.0 Hex nut zinc	1
23	M6x1.0 NYLOCK	M6x1.0 Nylon lock nut	4
24	M6x1.0x12 HHCS	M6x1.0x12 Hex head cap screw GR8.8 zinc	3
25	M6x1.0x25 HHCS	M6x1.0x25 Hex head cap screw GR8.8 zinc	1
26	M6x1.0x30 HHCS	M6x1.0x30 Hex head cap screw GR8.8 zinc	4
27	M8 FW	M8 Flat washer zinc	4
28	M8x1.25 NUT	M8x1.25 Hex nut zinc	2
29	M8x1.25x25 HHCS	M8x1.25x25 Hex head cap screw GR8.8 zinc	2
30	M10 FW	M10 Flat washer zinc	4
31	M10 FEN. W	M10x25 Fender washer	4
32	M10 SLW	M10 Med split lock washer zinc	2
33	M12x1.75 NUT	M12-1.75 Hex nut zinc	2
34	M10x1.5 NYLOCK	M10-1.5 Nylon lock nut	2
35	M10x1.5x16 HHCS	M10x1.5x16 Hex head cap screw GR 8.8	2
36	M10x1.5x35 HHCS	M10x1.5x35 Hex head cap screw GR 8.8	2
37	M10x1.50x40 FHCS FT	M10x1.50x40 Flat socket cap screw GR 10.9	3
38	M12x1.75x40 HHCS	M12x1.75x40 Hex head cap screw GR 8.8	2
39	M12x1.75x65 HHCS	M12x1.75x65 Hex head cap screw GR 8.8 zinc	2
40	M12x1.75 JAM NUT	M12x1.75 Hex jam nut zinc	2
41	M14 FW	M14x25mm Flat washer zinc	2
42	M14 FEN. W	M14x30mm Fender washer zinc	2
43	M14 SLW	M14 Med split lock washer zinc	2
44	M14 NYLOCK NUT	M14 Nylon locknut	2
45	M6x1.0x6 SSS	M6x1.0x6 Socket set screw	2
46	M8x1.25x125 EYE	M8x1.25x125mm Eye bolt (55mm of thread)	2
47	CP-3.5x58	Cotter pin 3.5x58mm	2



# PARTS & DIAGRAMS

## WM-8M Mechanical Wood Chipper Diagram 4 – Drive Components/Jackshaft

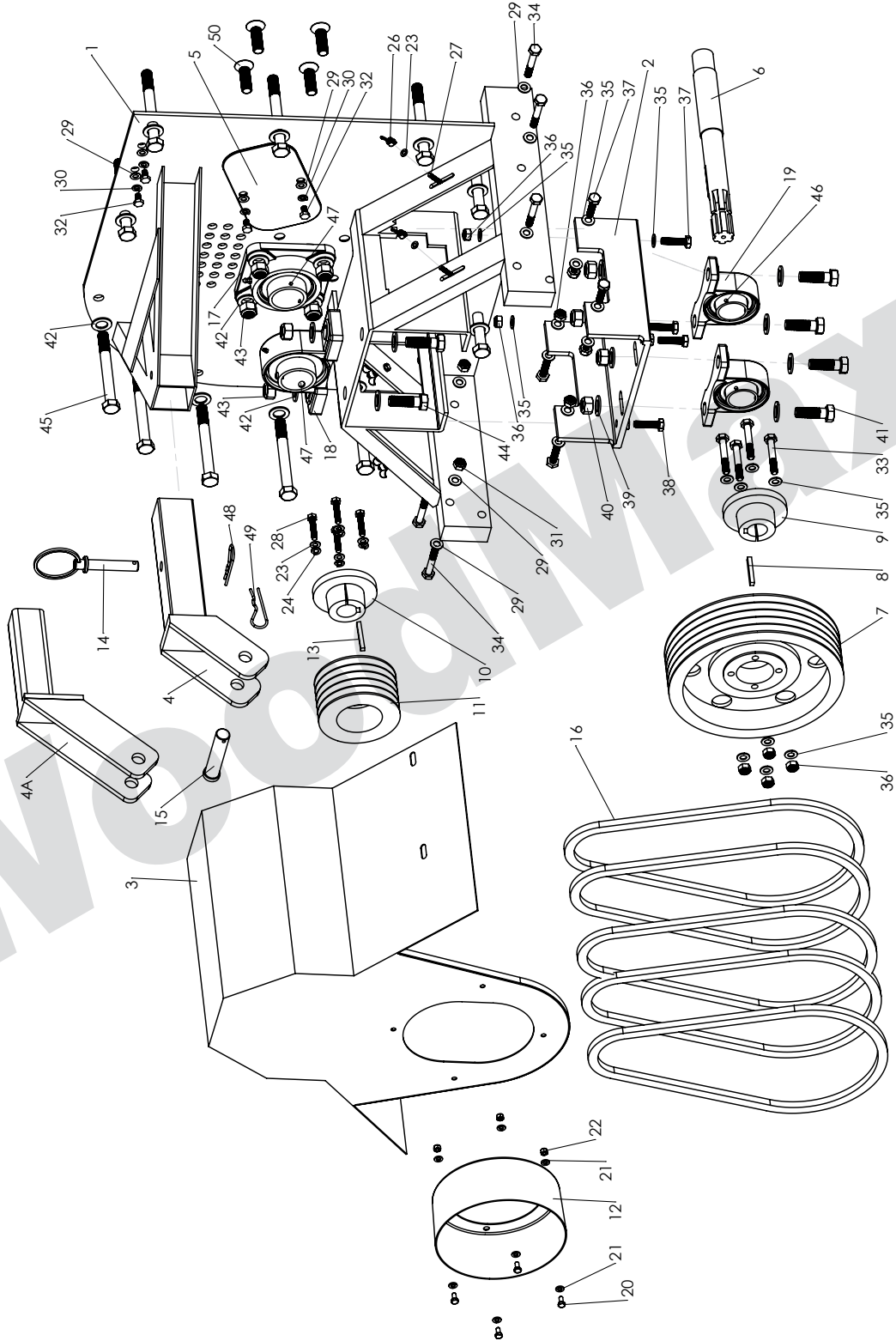

# PARTS & DIAGRAMS

## WM-8M Wood Chipper – Diagram 4 – Drive Components/Jackshaft – Parts List

POS #	PART #	PART DESCRIPTION	QTY
1	WM8-4-1	Flywheel housing half (PTO side)	1
2	WM8-4-2	Jackshaft bearing mounting plate	1
3	WM8-4-3	Belt cover	1
4	WM8-4-4	Top link weldment (standard)	1
4a	WM8-4-4A	Top link weldment (I-match compatible)	Opt
5	See Dia-2 #5	Chipper knife access panel	1
6	WM8-4-6	Jack shaft	1
7	WM8-4-7	sheave / jackshaft	1
8	K-.4375x2.00	Shaft key, Jackshaft / Taper lock (7/16" x 2")	1
9	WM8-4-9	Taper lock / jackshaft to sheave	1
10	WM8-4-10	Taper lock / spindle shaft to sheave	1
11	WM8-4-11	Sheave, spindle shaft	1
12	WM8-4-12	PTO Shield	1
13	K-.375x2.00	Shaft key, Taper lock / Spindle shaft (3/8" x 2")	1
14	P-.625x3.25	Top link weldment lick pin (5/8"x 3-1/4")	1
15	TLP-1	Top link pin (3/4" x 3-3/4")	1
16	BX46	BX46 V-belt	5
17	UCFL210-50	Flange bearing 4 bolt (UCFL210-50mm 4 hole flange)	1
18	P210-50	Pillow block bearing 2 bolt (P210-50mm 2 hole)	1
19	P207-35	Pillow block bearing 2 bolt (P207-35mm 2 hole)	2
20	M6x1.0x12 HHCS	M6x1.0x12 Hex head cap screw	4
21	M6 FFW	M6 Flat fender washer zinc	8
22	M6x1.0 Nylock Nut	M6 Nylon lock nut20	4
23	M8 FW	M8 Flat washer zinc	8
24	M8 SLW	M8 Med split lock washer zinc	4
25	M8x1.25 NUT	M8x1.25 Hex nut zinc	4
26	M8x1.25 WINGNUT	M8x1.25 Wing nut zinc	4
27	M8x1.25x30 HHCS	M8x1.25x30 Hex head cap screw GR8.8 zinc	4
28	M8x1.25x40 HHCS	M8x1.25x40 Hex head cap screw GR8.8 zinc	4
29	M10 FW	M10 Flat washer zinc	2
30	M10 SLW	M10 Med split lock washer zinc	2
31	M10x1.5 NYLOCK	M10-1.5 Nylon lock nut	6
32	M10x1.5x16 HHCS	M10x1.5x16 Hex head cap screw GR 8.8	2
33	M12x1.75x70 HHCS	M12x1.75x70 Hex head cap screw GR 8.8	4
34	M10x1.5x60 HHCS	M10x1.5x60 Hex head cap screw GR 8.8	6
35	M12 FW	M12 Flat washer zinc	4
36	M12x1.75 NYLOCK	M12-1.75 Nylon lock nut	4
37	M12x1.75x30 HHCS	M12x1.75x30 Hex head cap screw GR 8.8 zinc	4
38	M12x1.75x40 HHCS	M12x1.75x40 Hex head cap screw GR 8.8 zinc	2
39	M14 FW	M14x25mm Flat washer zinc	8
40	M14 NYLOCK NUT	M14 Nylon locknut	4
41	M14x1.50x50 HHCS	M14x1.50x50 hex head cap screw GR 8.8	4
42	M16 FW	M16 Flat washer zinc	4
43	M16x2.0 NYLOCK	M16x2.0 Nylon lock nut zinc	4
44	M16x2.0x50 HHCS	M16x2.0x50 Hex head cap screw zinc	2
45	M16x2.0x160 HHCS	M16x2.0x160 Hex head cap screw zinc GR8.8	13
46	M8x1.25x8 SSS	M8x1.25x8 Socket set screw	4
47	M10x1.25x10 SSS	M10x1.25x10 Socket set screw	2
48	RP-3x68	R-shaped cotter pin (3x68mm OAL)	2
49	RP-4x84	R-shaped cotter pin (4x84mm OAL)	2
50	M16x2.0x50 FHCS FT	M16x2.0x50 Flat head cap screw GR 8.8 (full thread)	4

# PARTS & DIAGRAMS

## WM-8M Mechanical Wood Chipper Diagram 5 – Discharge Chute

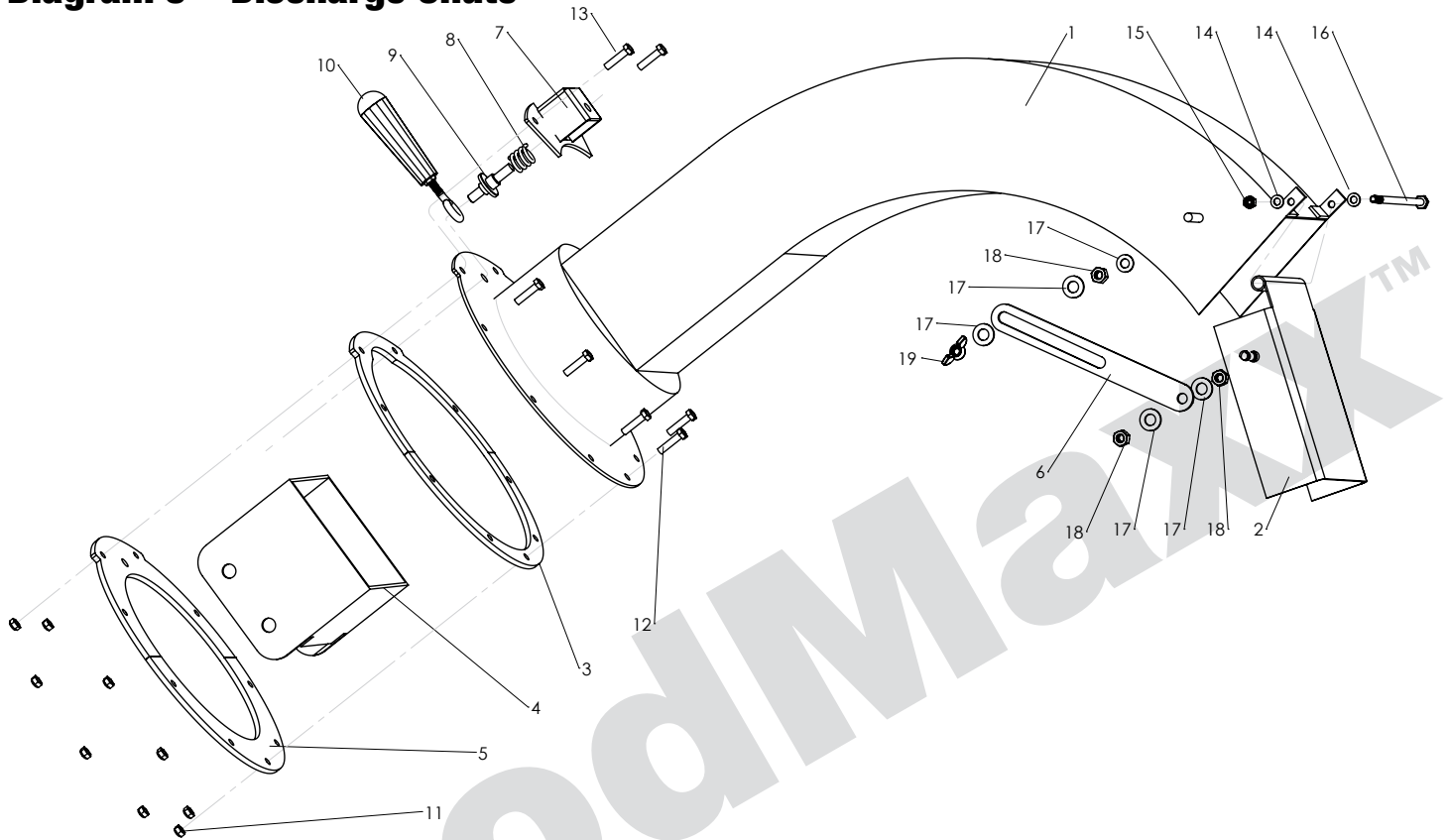

POS #	PART #	PART DESCRIPTION	QTY
1	WM8-5-1	Discharge Chute weldment	1
2	WM8-5-2	Discharge chute deflector	1
3	WM8-5-3	Spacer ring	1
4	WM8-5-4	Housing adaptor weldment	1
5	WM8-5-5	Lower assembly ring	1
6	WM8-5-6	Deflector adjustment arm	1
7	WM8-5-7	Index pin housing	1
8	WM8-5-8	Index spring pin	1
9	WM8-5-9	Index pin	1
10	WM8-5-10	Handle with eyebolt (M10x1.5x40 100mm OAL)	1
11	M6x1.0 NYLOCK	M6x1.0 Nylon lock nut	8
12	M6x1.0x20 HHCS	M6x1.0x20 Hex head cap screw GR8.8 zinc	6
13	M6x1.0x25 HHCS	M6x1.0x25 Hex head cap screw GR8.8 zinc	2
14	M8 FW	M8 Flat washer zinc	2
15	M8x1.25 NYLOCK	M8x1.25 Nylon lock nut	1
16	M8x1.25x140 HHCS	M8x1.25x140 Hex head cap screw GR8.8 zinc	1
17	M10 FW	M10 Flat washer zinc	1
18	M10x1.5 NUT	M10-1.5 Hex nut zinc	2
19	M10x1.5 KNOB	M10-1.5 (7 lobe Knob)	1

# PARTS & DIAGRAMS

## WM-8M Wood Chipper– Diagram 6 – Manual Base

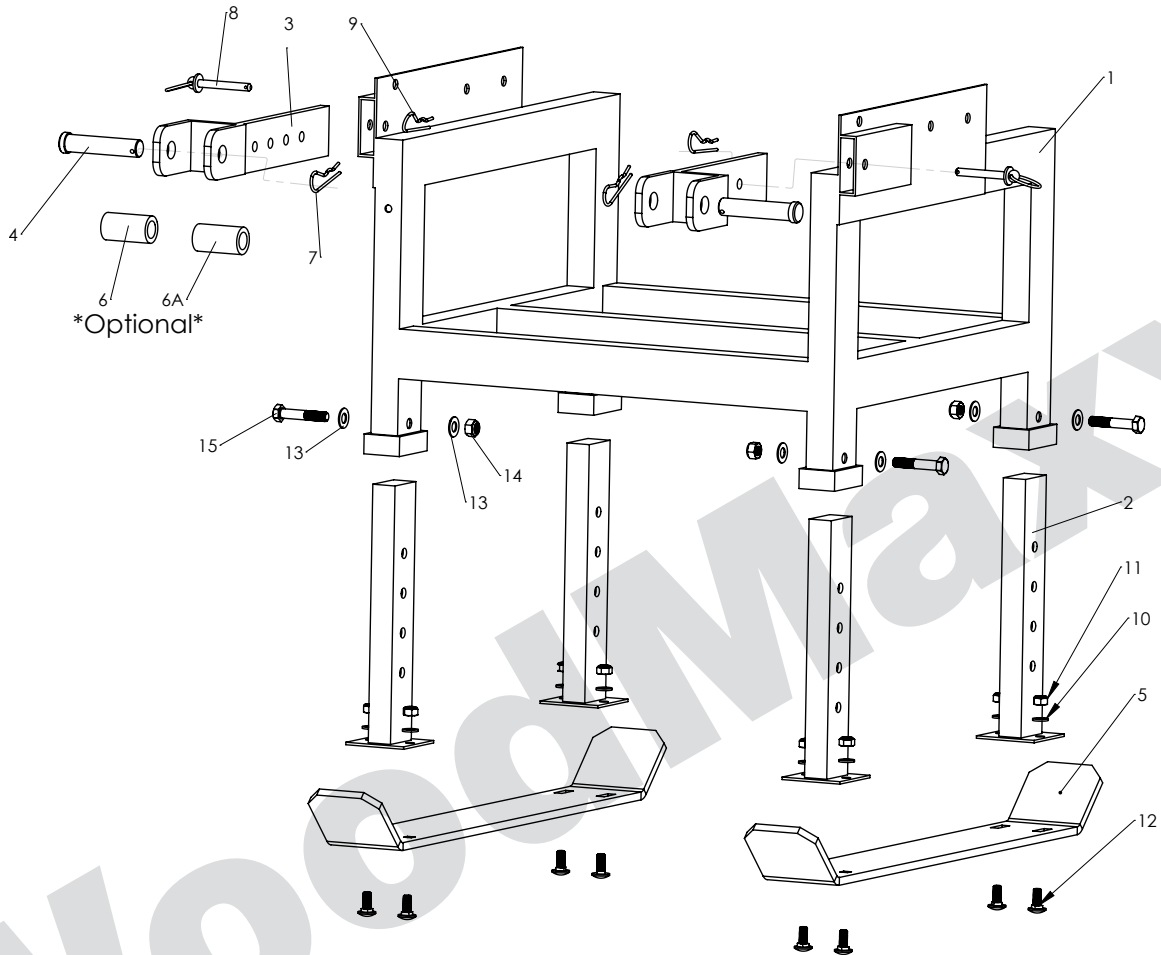

POS #	PART #	PART DESCRIPTION	QTY
1	WM8M-6-1	Frame weldment	1
2	WM8-6-2	Adjustable base leg	4
3	WM8-6-3	3 point hitch bracket, lower	2
4	HP-Cat-1	Hitch pin (Lower) (7/8" x 3-7/8")	2
5	WM-8-6-5	Base skid shoe	2
6	BUSH-1-2	Bushing (Cat-1 to Cat-2) Optional	2
6A	BUSH-QH	Bushing (Quick hitch) Optional	opt
7	RP-4x84	R-shaped cotter pin (4x84mm OAL)	2
8	P-12x82	Hitch bracket lock pin (12x82mm (3-1/4"))	2
9	RP-3x68	R-shaped cotter pin (3x68mm OAL)	2
10	M10 FW	M10 Flat washer zinc	16
11	M10x1.5 NYLOCK	M10-1.5 Nylon lock nut	16
12	M10x1.5x30 CARR	M10x1.5x30 Carriage bolt	8
13	M12 FW	M12x25mm Flat washer zinc	8
14	M12x1.75 NYLOCK	M12-1.75 Nylon lock nut	4
15	M12x1.75x60 HHCS	M12x1.75x60 Hex head cap screw GR 8.8 zinc	4

# PARTS & DIAGRAMS

## WM-8M Wood Chipper – Diagram 7 – Mechanical Drive

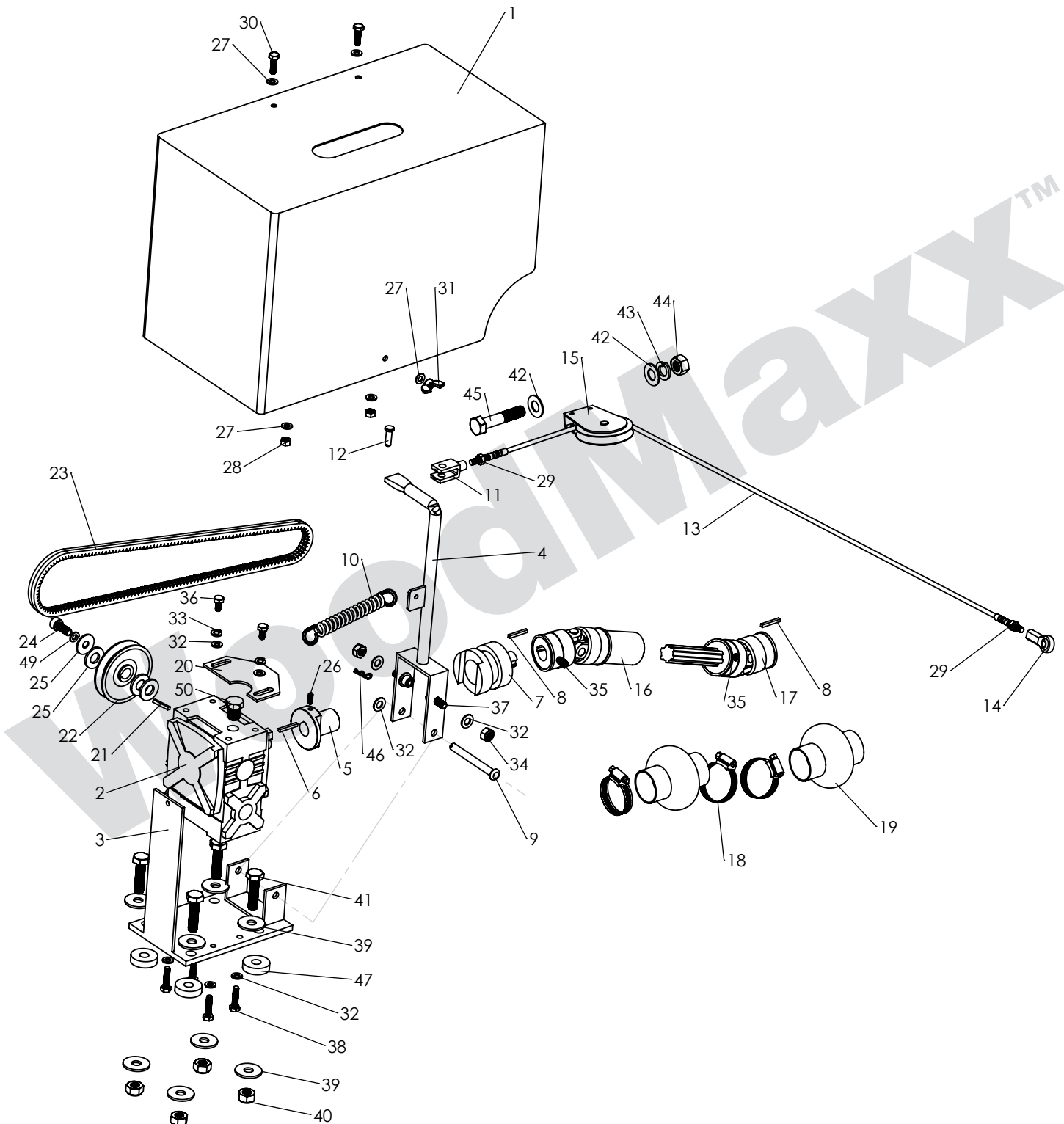

# PARTS & DIAGRAMS

## WM-8M Wood Chipper – Diagram 7 – Mechanical Drive – Parts List

POS #	PART #	PART DESCRIPTION	QTY
1	WM8M-7-1	Cover	1
2	WM8M-7-2	Gear reducer	1
3	WM8M-7-3	Mount plate, gear reducer	1
4	WM8M-7-4	Clutch (male half)	1
5	WM8M-7-5	Clutch drive	1
6	K-5x5x24	Key, gearbox output shaft (5mm x 5mm x 24mm)	1
7	WM8M-7-7	Clutch (female half)	1
8	K-6x6x16	Key, driveshaft (6mm x 6mm x 16mm)	2
9	WM8M-7-9	Pin, Lever pivot	1
10	WM8M-7-10	Spring, clutch	1
11	WM8M-7-11	Clevis, safety cable (clutch end)	1
12	WM8M-7-12	Clevis spring clip	1
13	WM8M-7-13	Clutch to safety bar cable	1
14	WM8M-7-14	Ball joint cable end	1
15	WM8M-7-15	Cable pulley	1
16	WM8M-7-16	In-feed axle shaft (female half)	1
17	WM8M-7-17	In-feed axle shaft (male half)	1
18	HC-20	SAE 20 hose clamp (1-1/4" to 1-3/4" -9/16" wide)	4
19	WM8M-7-19	U-joint rubber boot cover	2
20	WM8M-7-20	Clutch lever limit plate	1
21	K-4x4x20	Key, gearbox input shaft (4mm x 4mm x 20mm)	1
22	WM8M-7-23	Gear box drive pulley	1
23	AX32	Pump V-belt (AX32)	1
24	M5x.8x15 SHCH	M5x0.8x15 Socket head cap screw	1
25	M5 FEN. W	M5 Fender washer zinc	1
26	M5x.8x10 SSCR	M5x0.8x10 Socket set screw	1
27	M6 FW	M6 Flat washer zinc	1
28	M6x1.0 NYLOCK	M6x1.0 Nylon lock nut	2
29	M6x1.0 JAM NUT	M6 x1.0 Jam nut zinc	2
30	M6x1.0x25 HHCS	M6x1.0x25 Hex head cap screw GR8.8 zinc	2
31	M6x1.0 WINGNUT	M6x1.0 Hex wing nut zinc	1
32	M8 FW	M8 Flat washer zinc	2
33	M8 SLW	M8 Med split lock washer zinc	2
34	M8x1.25 NYLOCK	M8x1.25 Nylon lock nut	2
35	M8x1.25x10 SSS	M10x1.25x10 Socket set screw	2
36	M8x1.25x20 HHCS	M8x1.25x20 Hex head cap screw GR8.8 zinc	2
37	M8x1.25x20 SHCS	M8x1.25x20 Socket head cap screw	2
38	M8x1.25x25 SHCS	M8x1.25x25 Hex head cap screw	4
39	M10 FW	M10 Flat washer zinc	4
40	M10x1.5 NYLOCK	M10-1.5 Nylon lock nut	4
41	M10x1.5x30 HHCS	M10x1.5x30 Hex head cap screw GR 8.8	4
42	M12 FW	M12x25mm Flat washer zinc	2
43	M12 SLW	M12 Med split washer zinc	1
44	M12x1.75 NUT	M12x1.75 Hex nut zinc	1
45	M12x1.75x65 HHCS	M12x1.75x65 Hex head cap screw GR 8.8 zinc	1
46	RP-1.5x33	R-shaped cotter pin (1.5x33mm OAL)	1
47	WM8M-7-47	Bushing, Mount, Gear reducer	4
48	M14 FW	M14 Flat Washer	3
49	M5 SLW	M5 Split lock washer zinc	1
50	WM8M-7-50	1/4-19 BSPT Plastic plug	1

# NOTES

---

---

---

---

---

---

---

---

---

---

---

---

---

---

---

---

---

---

---

---

---

---

---

---

---

---

---

---

---

---

WoodMaxx™







## LIMITED WARRANTY

**WOODMAXX™** POWER EQUIPMENT, LTD. ("**WOODMAXX™**") warrants its products to the original retail purchaser as follows:

### WARRANTY

**WOODMAXX™** warrants MX-series, WM-series, TM-series chipper and sawmill parts only to be free from defects in material and workmanship for three (3) years from the date of original purchase except where otherwise noted. Backhoe, snow blower, WC-series chipper, tiller, flail mower, DC-Chipper and log splitter parts are warranted to be free from defects in material and workmanship for two (2) years from the date of original purchase except where otherwise noted. Electrical components are warranted for 60 days, beginning on the date of delivery. Hydraulic hoses are warranted for 30 days, beginning the date of delivery. PTO shafts are warranted for 90 days, beginning at the date of delivery. Proof of purchase (original receipt) is required. The exclusive remedy for this warranty is that **WOODMAXX™** will, at its option, provide replacement parts for this product. This is a parts warranty and specifically excludes labor. **WOODMAXX™** reserves the right to discontinue or change materials, parts, models or products, or to make substitutions. **WOODMAXX™** will ship all replacement parts USPS mail or UPS ground, express shipping options are available only at an extra cost to the customer. Photos of the damaged parts may be required for replacement. By purchasing a **WOODMAXX™** you agree to the terms of service as described in this warranty.

### WARRANTY LIMITATIONS

This warranty does not apply to normal wear and tear, commercial or rental use, after-market modification, or damages which arise from negligence, misuse, use not in accordance with the product instructions and if in the event there is a dispute, **WOODMAXX™** in its sole discretion will make the final decision with regard to whether or not the product is covered by the **WOODMAXX™** warranty. Repairs made under this warranty will not extend the warranty period. If you are unwilling or unable to perform the labor required on your **WOODMAXX™** product, **WOODMAXX™** will return the machine to the **WOODMAXX™** facilities. We will refund your purchase amount prorated according to the amount of use on the machine. All items must be returned with the machine, any missing parts will be deducted from the refund. The cost of shipping will be either the customer's responsibility or **WOODMAXX™**'s, which will be determined on a case by case basis.

### LIMITATION OF DAMAGES

The warranty and remedies as set forth above are exclusive and in lieu of all others, oral or written, express or implied. In no event will **WOODMAXX™** be liable for any damages, including incidental or consequential damages, arising out of the use or inability to use this product.

### LIMITATIONS OF WARRANTIES

Any express or implied warranties, including warranties of merchantability and fitness for a particular purpose, shall be limited to the duration and terms of the express written warranty.

### WARRANTY PARTS POLICY

If covered replacement parts are not in stock, they will be ordered by **WOODMAXX™** and the customer will be notified when replacements parts are available. **WOODMAXX™** will not be liable for any damages associated with the unavailability of parts, including consequential damages or delay damages. **WOODMAXX™** may require a deposit for parts sent out if the part **WOODMAXX™** requires the defective part returned. **WOODMAXX™** reserves the right to refuse shipment of repair parts if the customer refuses to commit to a deposit. **WOODMAXX™** also may require pictures or videos of the issue in question before sending out parts. Any issues will be attempted to be resolved with providing of parts before returning the machine; any returns will be accepted at the sole discretion of **WOODMAXX™**.

### WARRANTY EXCLUSIONS

Belts, knives, hydraulic hoses, and finish are specifically excluded from this warranty. **WOODMAXX™** is not liable for any incidental damage caused by its products, including but not limited to, any damage to tractors or other machinery used in connection with its products. **WOODMAXX™** is not liable for damage incurred during shipping; any damage incurred in shipping must be noted on the bill of lading at the time the machine is accepted. A shipping damage claim will be made on your behalf. You also have the right to refuse the machine if it is severely damaged. **WOODMAXX™** does not offer or guarantee color matching with any particular tractor color. **WOODMAXX™** will not accept returns due to dissatisfaction with the color. If the customer is concerned about the color of the implement, the customer must request a paint sample before ordering.

# WoodMaxx

◆ Power Equipment Ltd. ◆



## IMPORTANT! SAFETY INSTRUCTIONS

- Read and understand operator's manual and all other safety instructions before using this equipment.
- Wear proper safety gear.
- Keep children away from the work area.
- Inspect machine before each use.

**WoodMaxx** Power Equipment, Ltd.

42 Jackson Street • Akron, NY 14001

**1.855.966.3629**

[www.WOODMAXX.com](http://www.WOODMAXX.com)

Name \_\_\_\_\_

Serial # \_\_\_\_\_

Date \_\_\_\_\_