



INSTRUCTION MANUAL

Vermont Porch Rocker

Ver. 2024



Series 4332

ⓘ NOTICE

- Chair is NOT RECOMMENDED FOR WEIGHT OF MORE THAN 250 LBS.
- Care should be taken to avoid tipping while seated.
- Chair is designed for use on level ground only.
- Do not lean or sit on arms to avoid harm or injury.
- This product is for residential use only.
- For missing hardware or concerns, please contact customerservice@shineco.com

Please check if you have received all parts & hardware & they are in good condition before assembly.

HARDWARE

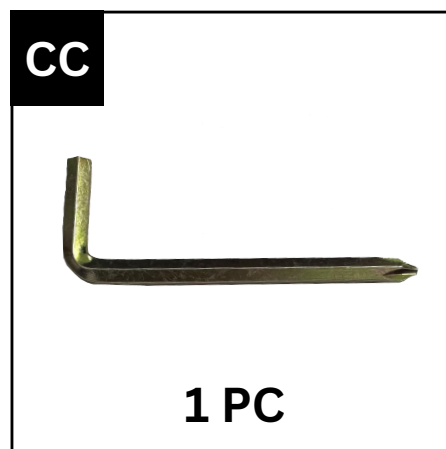
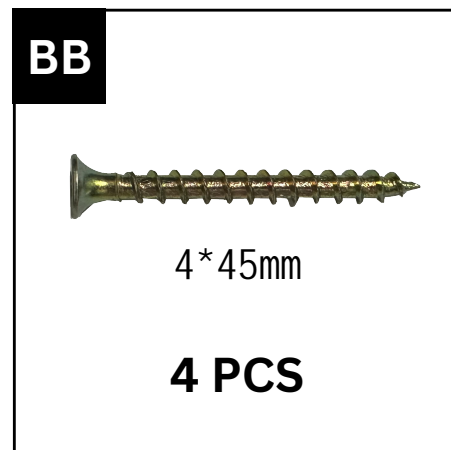
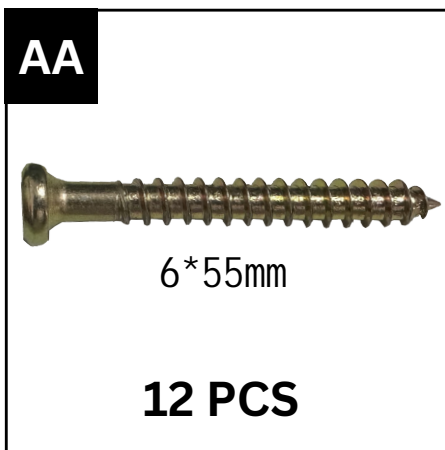

⚠ NOTICE

When assembling chair, **DO NOT** completely tighten nuts & bolts until all parts & holes are properly aligned & positioned.

PARTS

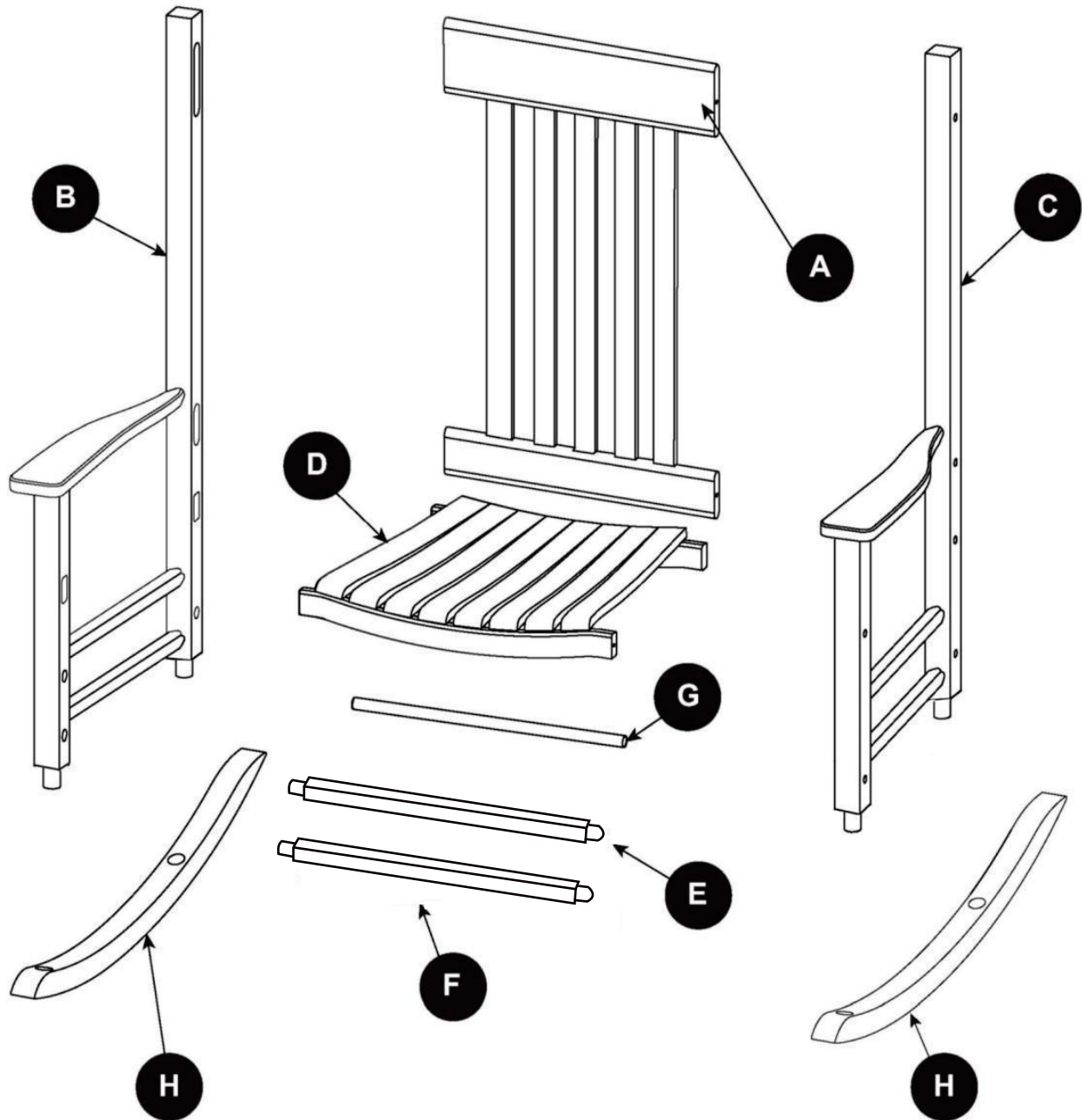

PRODUCT ASSEMBLY

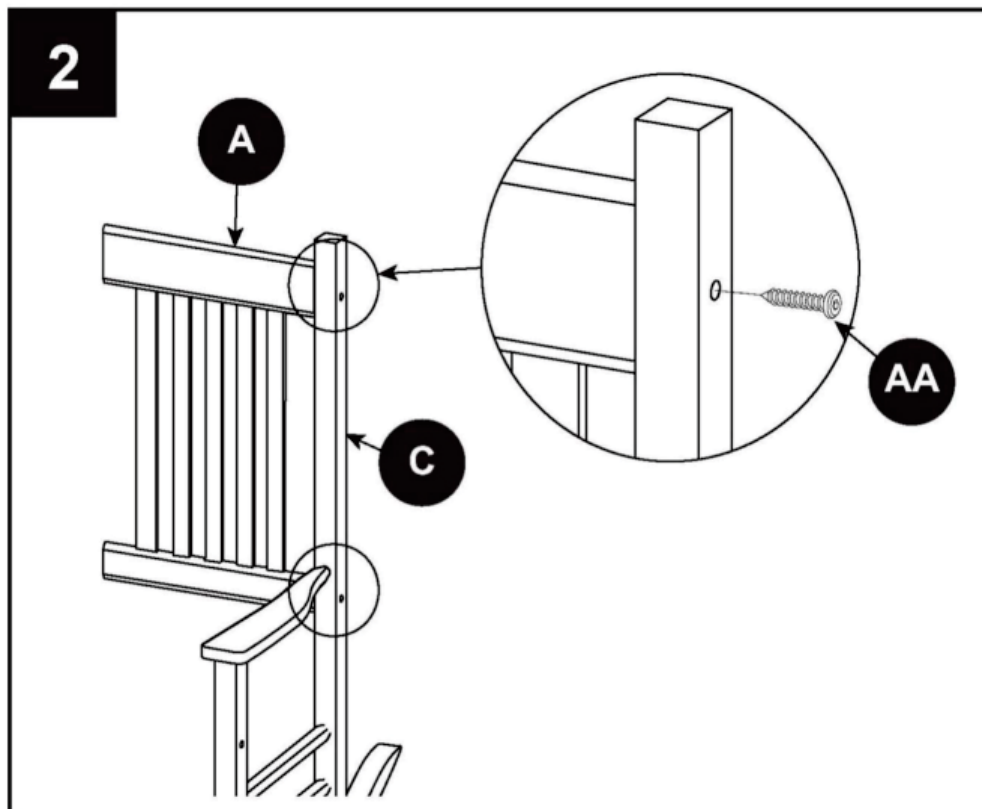
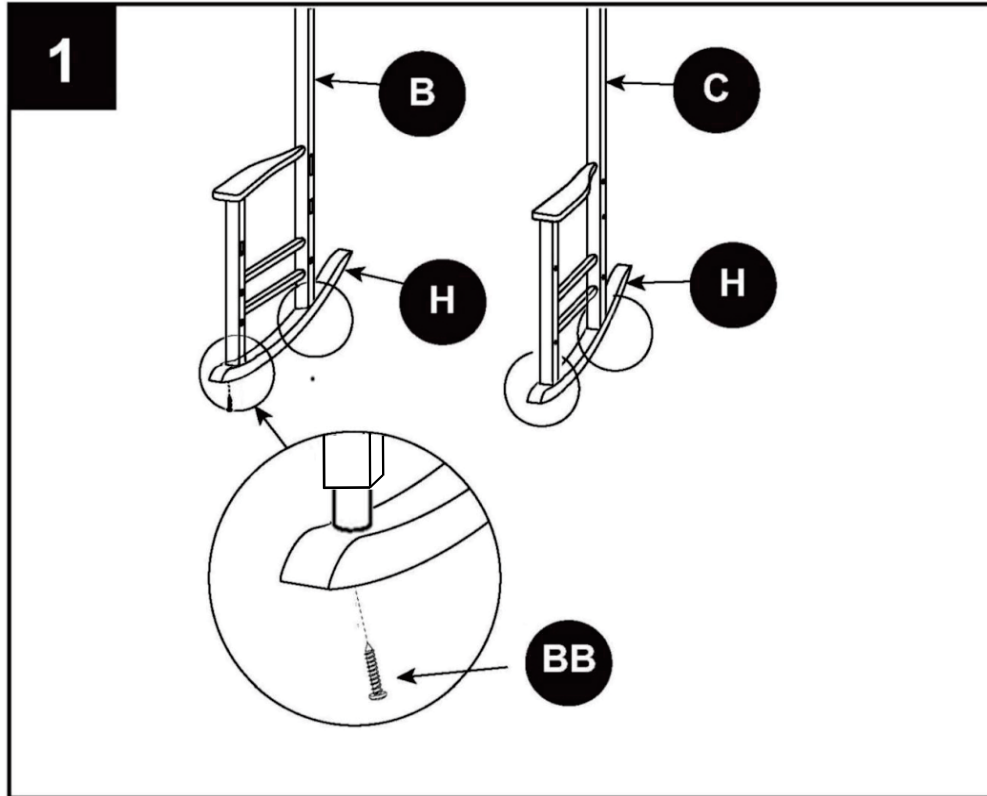

PRODUCT ASSEMBLY

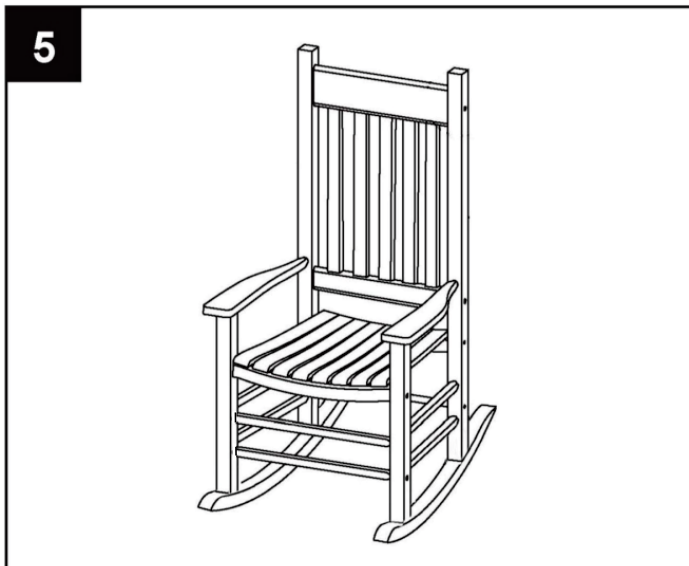
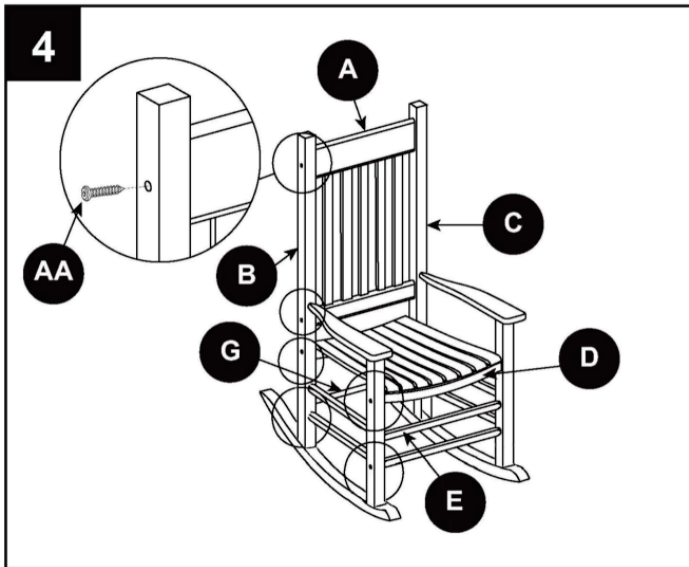
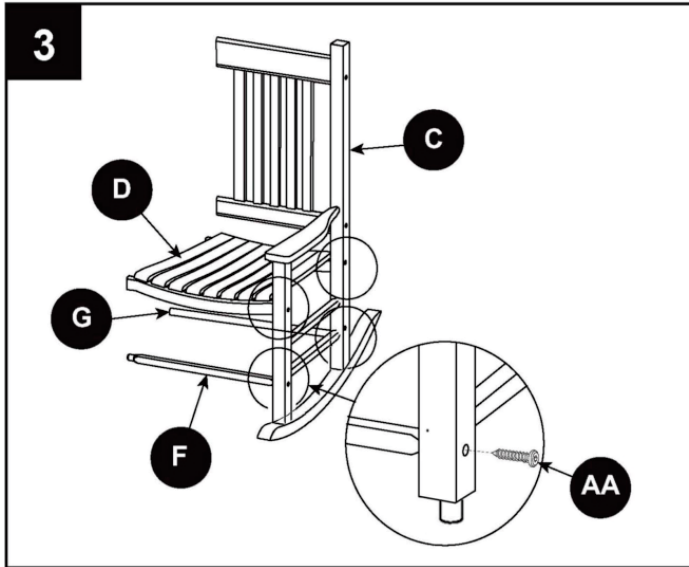

WOOD FURNITURE CARE

Congratulations on your purchase!
Now, you can sit back and enjoy your outdoor furniture for many years to come.

All wood products require care to keep them looking good and prevent premature weathering and deterioration.

It is highly suggested to put the painted furniture on a covered porch, patio or in a shady area for longevity. Dust/ Wipe with a soft cloth, clean with water, and air dry.

Due to the nature of wood, surface cracking and slight color variations will occur over time. Rest assured that the wood & product will remain structurally sound for years.



HELP CENTER



Missing Hardware or Parts?
Product Assembly? Returns or Refunds? or any
other questions about your product

Visit us at:
www.shineco.com
or email
customerservice@shineco.com

ⓘ **DISCLAIMER**

Our quality solid wood is kiln dried before they are made into furniture for outdoor use. Cedar is durable wood and has natural resistance to moisture decay and insect damage makes it the ultimate choice for interior or exterior use.

However, like all paints, natural weathering and cracking is to be expected. These factors do not constitute a reason to reject the product because it does not affect the structural integrity of the furniture. When properly maintained and finished, cedar/pine will supply you its splendor and beauty for many years.

All products are subject to slight variations in color, shape, or size due to manufacturing process.

Shine Company, Inc. cannot be held responsible or liable for any inconvenience, damage, loss, or injury due to possession, use or misuse of our products. Customers are solely responsible for ensuring the safety of any person or persons utilizing the furniture regardless of age while using, storing, holding, or owning our products.



WARRANTY INFORMATION

Wood Furniture Products

Shine Company provides (1) year of limited warranty for its Wood furniture products. This warranty covers residential use starting from the date of purchase. This warranty covers any defects in the manufacturing and workmanship of the furniture components. This warranty is limited to the original purchaser of the product(s).

Exclusions:

1. Shine Company shall not be liable for neglect of necessary care; improper assembly or mishandling of products, unintended or unreasonable use of products, deliberate misuse of products, the application of paint, varnish, or other chemical coating except where recommended by Shine Co., abuse of hardware caused defects by their assembly.
2. Wood cracking and checking are a normal part of all wood furniture and is rarely a result of any structural issue. When properly maintained and finished, cedar will supply you its splendor and beauty for many years.
3. This warranty specifically excludes coverage for fading, color change or color match on any group settings due to environmental condition. Shine Company's limited warranty does not cover wear and tear effects on the furniture under normal use, including scratches and scuffing marks and other cosmetic damages.
4. All products are subject to slight variations in color, shape, or size due to manufacturing process.
5. Unexpected acts of nature (fire, flood, lightning, ice, earthquake, acts of God, hurricanes, tornadoes, tropical storms, and any damage caused by wind over which Shine Company has no control).
6. The original purchaser is responsible for providing dated proof of purchase/receipts, photographs of damaged parts, and a written description of the defect. The original purchaser must inform Shine Company whether the product is for residential or commercial use for Shine Company to evaluate the warranty coverage for the product.
7. If the product is covered under warranty, three possible solutions are available (1) replacement of the defective merchandise, (2) replacement of defective component, or (3) authorized repairs by a third party. Shine Company shall determine which warranty solution shall apply after evaluating the information provided by the customer. The purchaser is responsible for all shipping charges to and from Shine Co.