

# GRILL CART WITH STORAGE

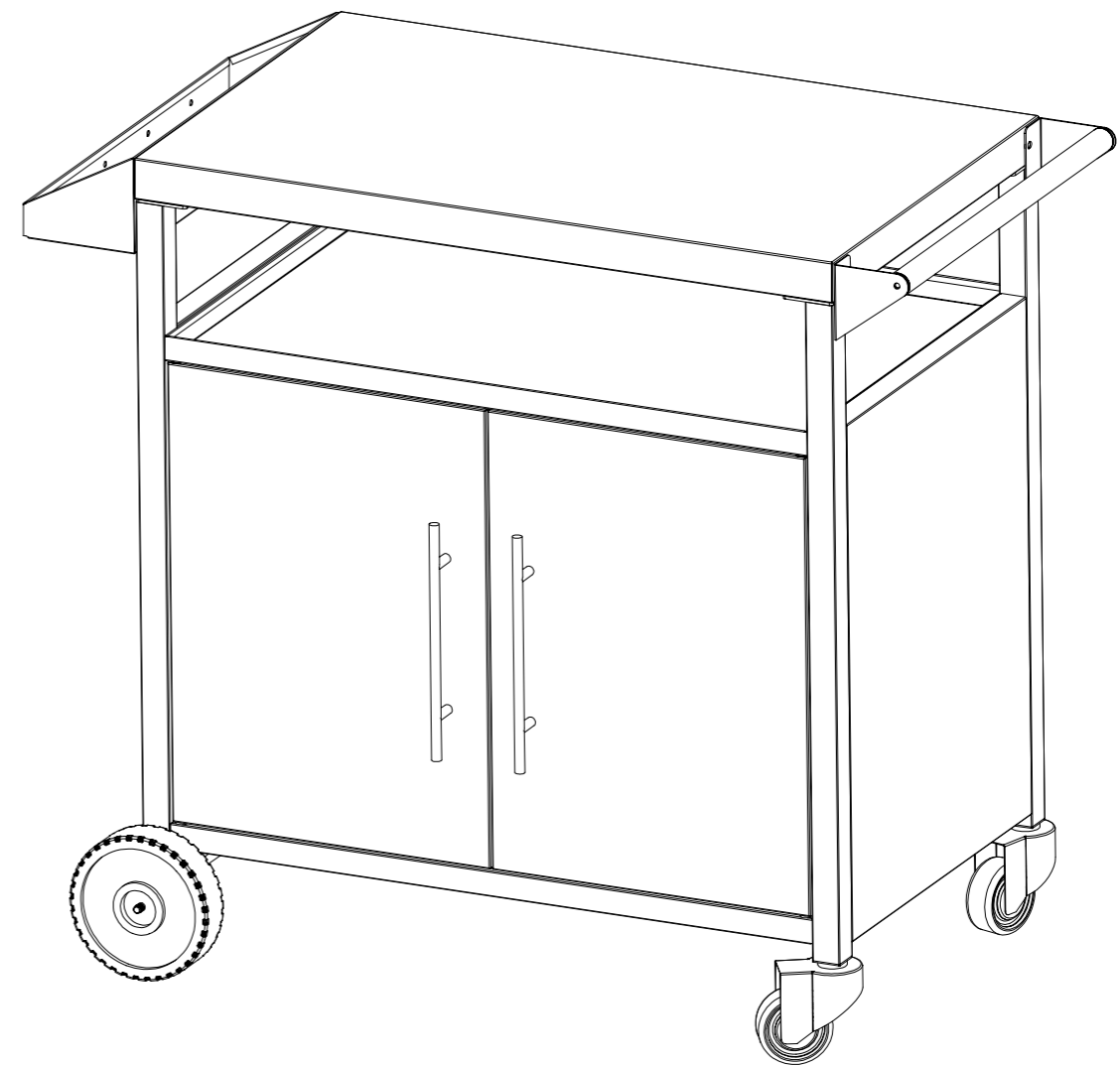

## ASSEMBLY INSTRUCTIONS INSTRUCCIONES DE ENSAMBLAJE

MODEL NUMBER: GC-02  
NÚMERO DE MODELO: GC-02



READ ALL SAFETY WARNINGS AND INSTRUCTIONS IN THE OWNER'S MANUAL BEFORE ASSEMBLING OR OPERATING YOUR GRILL.

LEA TODAS LAS ADVERTENCIAS DE SEGURIDAD E INSTRUCCIONES DEL MANUAL DEL PROPIETARIO ANTES DE MONTAR O PONER EN FUNCIONAMIENTO SU PARRILLA.

CONTENTS / CONTENIDO:

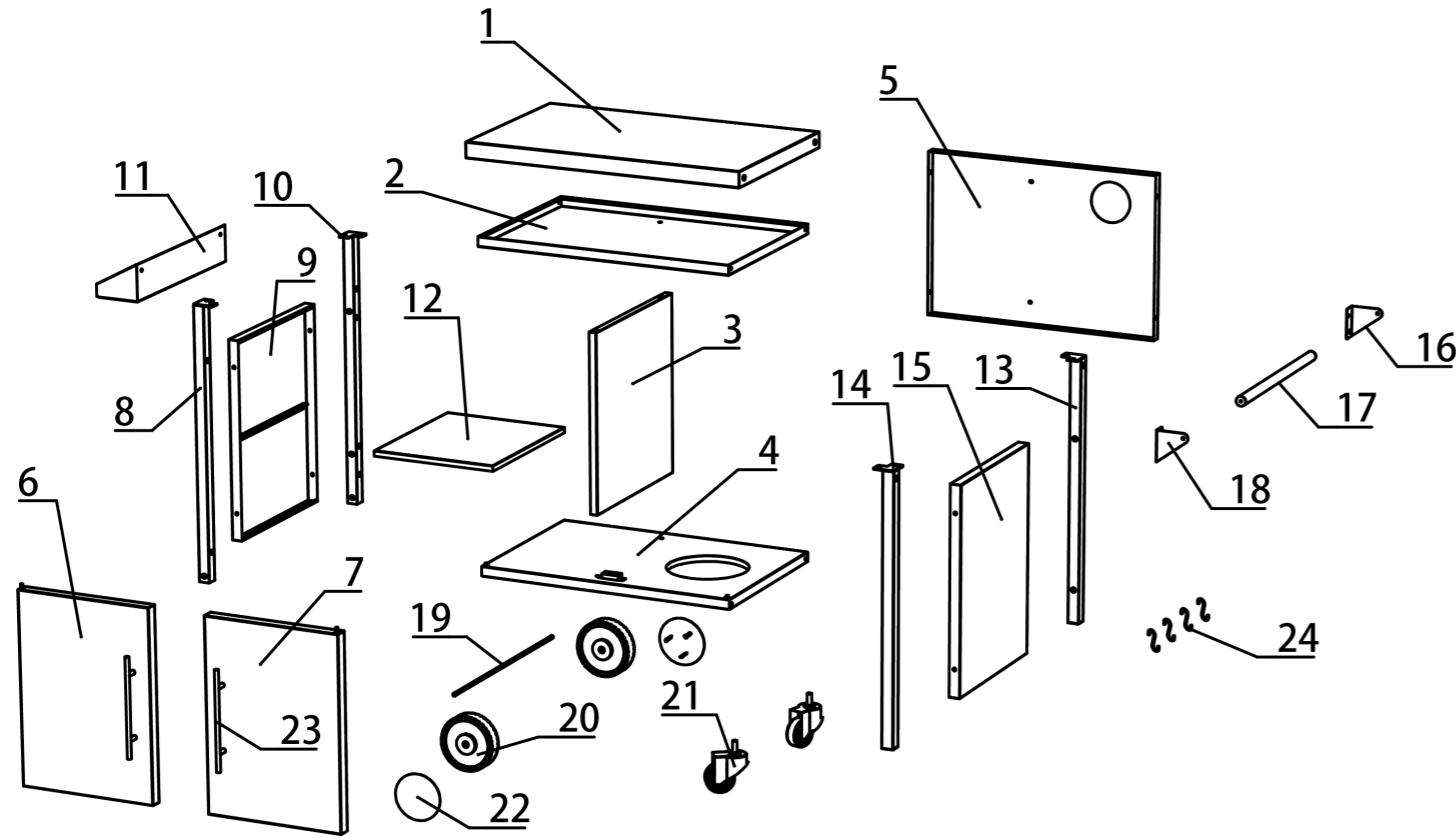

PARTS DIAGRAM

Item	Description	Qty.
1、	Table Top	1
2、	Second Shelf	1
3、	Locker Vertical Divider	1

4、	Base Shelf	1
5、	Back Board	1
6、	Cabinet Door - Left	1
7、	Cabinet Door - Right	1
8、	Long Support Leg - Left	1
9、	Side Board - Left	1
10、	Long Support Leg - Right	1
11、	Seasoning Box	1
12、	Locker Horizontal Divider	1
13、	Short Support Leg - Left	1
14、	Short Support Leg - Right	1
15、	Side Board - Right	1
16、	Handle Connecting Part - Left	1
17、	Handle	1
18、	Handle Connecting Part - Right	1
19、	Wheel Connecting Rod	1
20、	PE Wheels	2
21、	Universal Wheels	2
22、	Wheel Covers	2
23、	Door Handles	2
24、	S Pothook	4

⚠ Two person assembly recommended  
 ⚠ Se recomienda el montaje por dos

Tools required:  
 Herramientas necesarias:



Part#	Diagram	Description	Qty.
A		M6x12 Screw	42
B		M8 Lock Nut	2
C		M8 Gasket	4
D		M4x8 Screw	4
E		Hexagonal Spanner	1

**1.**

Fasten the long support leg - left (8), the side board (9) and the long support leg - right (10) with 4 M6x12 screws(A).

Fije la pata de apoyo larga - izquierda (8), el tablero lateral (9) y la pata de apoyo larga - derecha (10) con 4 tornillos M6x12(A).

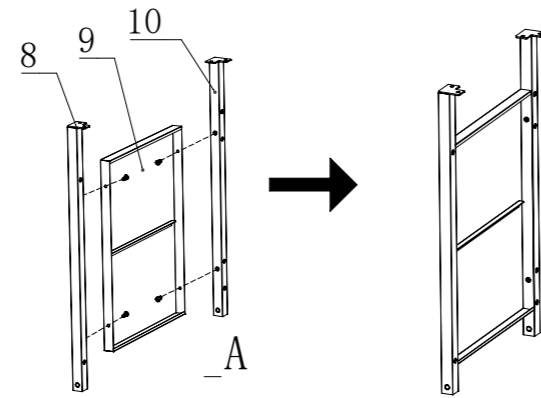

**2.**

Fasten the short support leg-left (13), the side board- right (15) and the short support leg - right (14) with 4 M6x12 screws(A).

Fije la pata de apoyo corta-izquierda (13), el tablero lateral-derecha (15) y la pata de apoyo corta-derecha (14) con 4 tornillos M6x12(A).

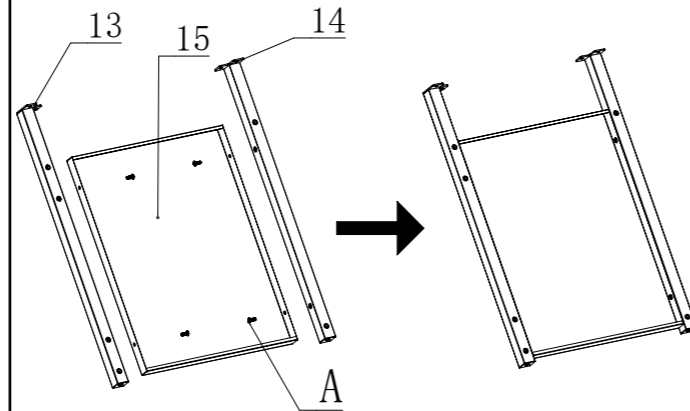

**3.**

Screw the above two assemblies and table top (1) with 8 M6x12 screws (A).

Atornille los dos conjuntos anteriores y el tablero de la mesa (1) con 8 tornillos M6x12 (A).

**Note:** For subsequent installation, do not tighten the screws fully.

**Nota:** Para la instalación posterior, no apriete completamente los tornillos.

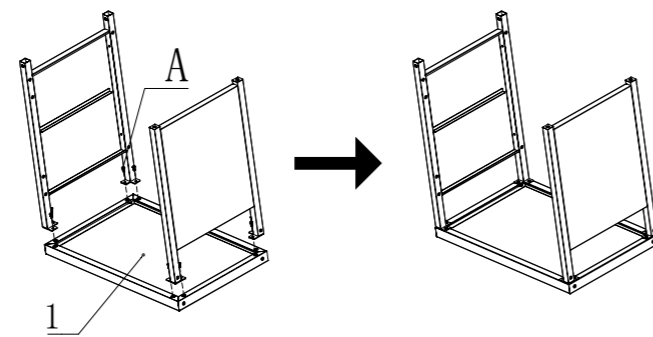

**4.**

Screw the above two assemblies and second shelf (2) with 4 M6x12 screws (A).

Atornille los dos conjuntos anteriores y el segundo estante (2) con 4 tornillos M6x12 (A).

**Note:** For subsequent installation, do not tighten the screws fully.

**Nota:** Para la instalación posterior, no apriete completamente los tornillos.

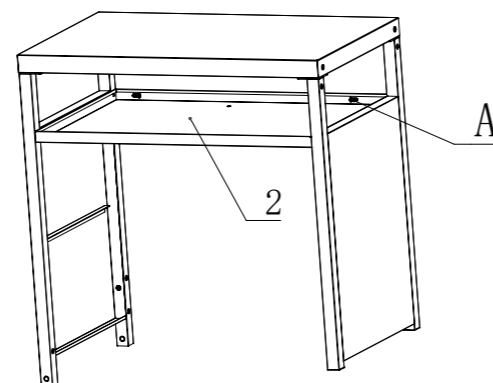

**5.**

Fasten the back board (5) with 4 M6x12 screws (A).

Fije la placa posterior (5) con 4 tornillos M6x12 (A).

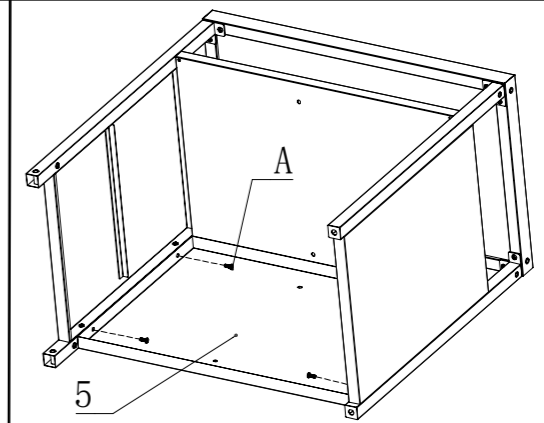

**6.**

Fasten the base shelf (4) with 4 M6x12 screws (A).

Fije el estante base (4) con 4 tornillos M6x12 (A).

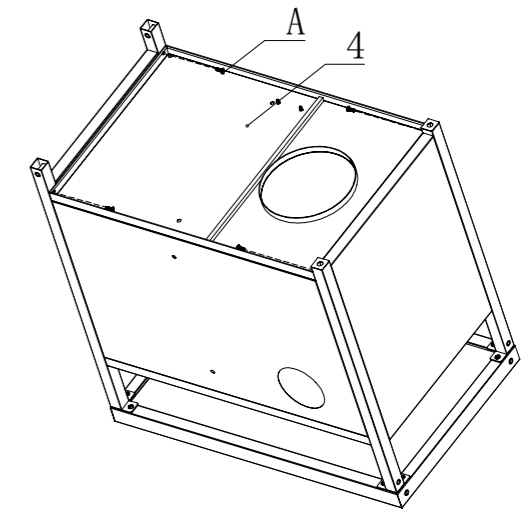

**7.**

Fasten the locker vertical divider (3) with 6 M6x12 screws (A).

Fije el separador vertical de la taquilla (3) con 6 tornillos M6x12 (A).

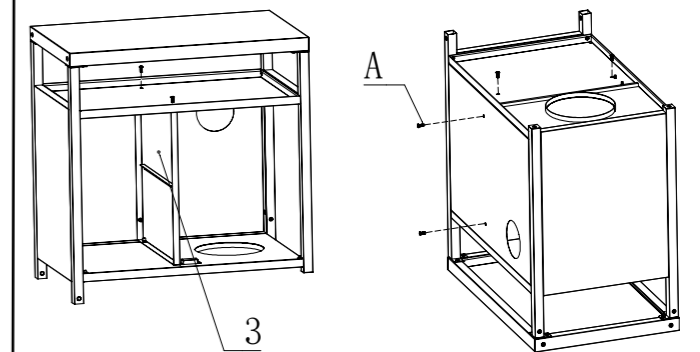

**8.**

Install the 2" universal wheels (21) in the appropriate position.

Instale las ruedas universales de 2" (21) en la posición adecuada.

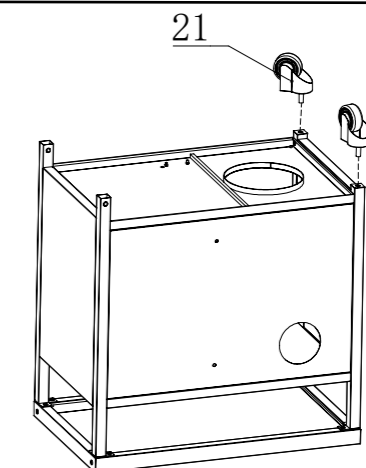

## 9.

After inserting the shaft rod (19) into the leg tube, 2 pe wheels (20) are set into the tube (pay attention to the direction of wheel installation, raised towards the inside). Add wheel covers (22) on both sides, and fixed with lock nuts (B). Force wheel covers (22) into the PE wheel inside.

Después de insertar la varilla del eje (19) en el tubo de la pata, se colocan 2 ruedas pe (20) en el tubo (preste atención a la dirección de instalación de la rueda, levantada hacia el interior). Añada cubiertas de rueda (22) a ambos lados, y fíjelas con contratuercas (B). Introduzca los tapacubos (22) en el interior de la rueda de PE.

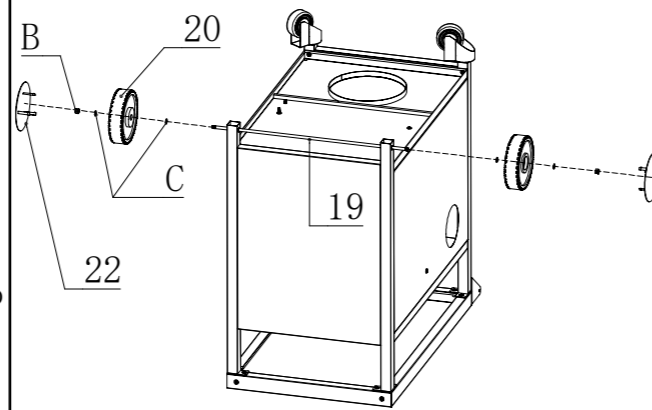

## 10.

Place the locker horizontal divider (12) flat on the shelf.

Coloque el separador horizontal de la taquilla (12) plano sobre la estantería.

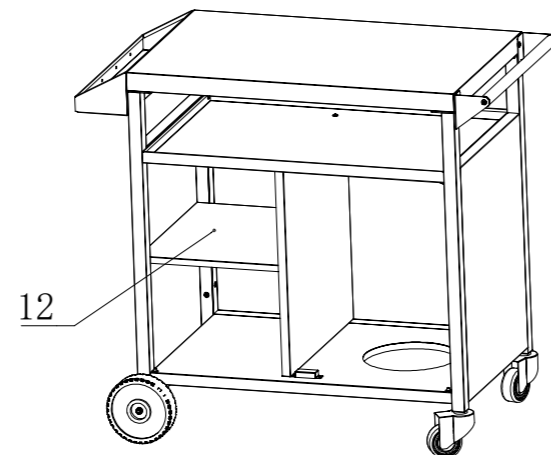

## 11.

Fasten handle connecting part - left (16) and handle connecting part - right (18) to the mounted body with 4 screws M6x12(A).

Fije la pieza de conexión de la empuñadura - izquierda (16) y la pieza de conexión de la empuñadura - derecha (18) al cuerpo montado con 4 tornillos M6x12(A).

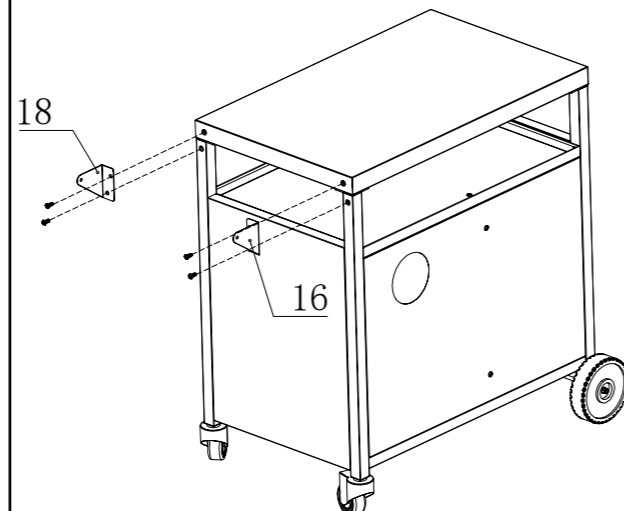

## 12.

Fasten handle (17) with 2 M6x12(A) screws to the handle connecting parts just installed.

Fije la empuñadura (17) con 2 tornillos M6x12(A) a las piezas de unión de la empuñadura que se acaban de instalar.

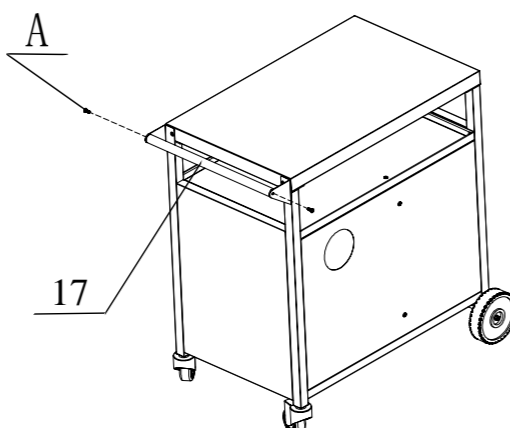

## 13.

Fasten the seasoning box (11) with 2 M6x12 screws (A).

Fije la caja de condimentos (11) con 2 tornillos M6x12 (A).

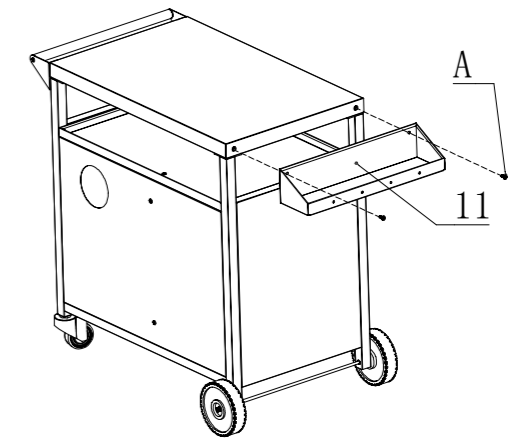

## 14.

Fix the cabinet door-left (6) and door handle (23) with 2 M4x8 screws.

Fije la puerta izquierda del armario (6) y el tirador de la puerta (23) con 2 tornillos M4x8.

Cabinet door - right (7) mounted in the same way.

Puerta de armario - derecha (7) montada de la misma manera

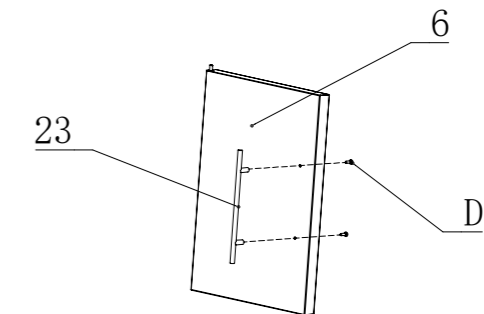

## 15.

Insert the small hole at the bottom of the cabinet door-left (6) into the pin and press the upper spring so that it snaps into the upper hole.

Introduzca el pequeño orificio de la parte inferior de la puerta izquierda del armario (6) en el pasador y presione el muelle superior para que encaje en el orificio superior.

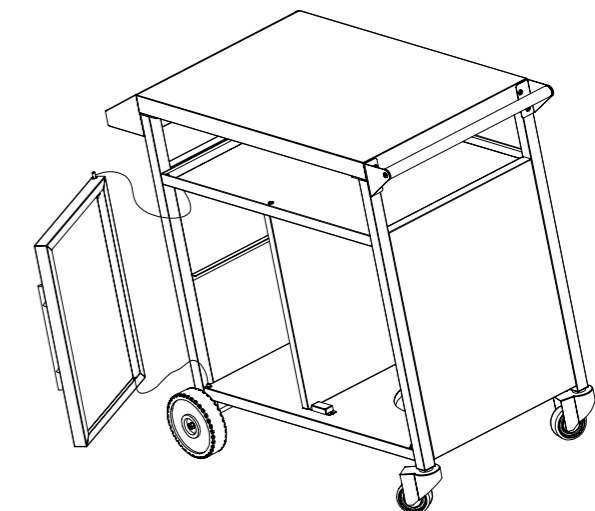

## 16.

Cabinet door-Right (7) and cabinet door-Left (6) are mounted in the same way.

La puerta derecha del armario (7) y la puerta izquierda del armario (6) se montan de la misma manera.

