

# Installation Instructions

## SL501A LED Beacon

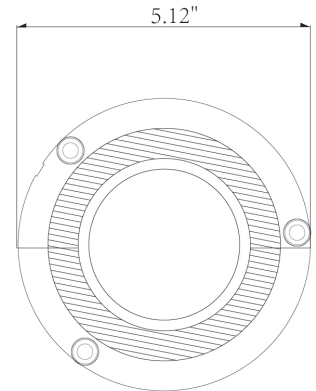

Flash Pattern Selector

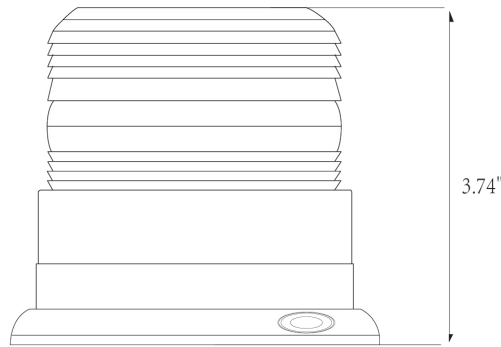

### Specifications

40 LEDs  
0.6 Amps @ 12V  
7.2 W  
3-3/4" x 5-1/8" Diameter

Flash Pattern	Description
1	Rotate
2	Flash

**Note:** Press pattern button 0.5 seconds for next pattern

Beacon can be magnetically mounted or permanently mounted using the (3) attachment points.

Beacon can be hardwired by cutting of the accessory plug, leaving enough wire to properly connect.

- Red (+) Positive, Black (-) Ground = Rotate
- Red (+) Positive, Black & Yellow (-) Ground = Flash

### WARNING

Do not look directly into LEDs while in operation; may cause momentary blindness and/or eye damage.

### WARNING

It is not recommended to use magnetically mounted warning devices on vehicles in motion. Usage is at sole risk and responsibility of the user

### WARRANTY

Buyers Products Company warranties all LED Strobe and LED Work Light products to the original owner against defects in workmanship and material for a period of one (1) year from the date of purchase unless otherwise specified. Buyers Products must review each warranty claim and reserves the right to offer a refund for the original sale price of the product or replace the defective light. The five (5) year warranty is non transferable, applies to the original owner, and is subject to the following terms and conditions. The warranty will be void in cases of misuse, severe abuse, and failure to properly install the LED Light. Breakage of the lens or housing, corrosion at the plug, wire wicking, voltage spikes, and product failure caused by road chemicals and acid type washes are not warrantable claims. This warranty gives you specific legal rights and you may also have other legal rights that vary from state to state.