

# 20IN Egg-shaped Grill//Gril en forme d'oeuf 20PO

Item/Article #: A504002323

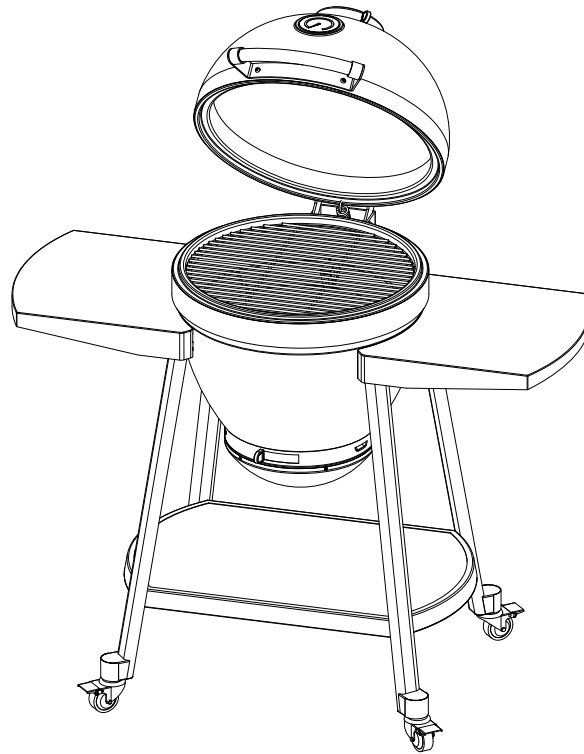

***Questions? Issues? Missing Part? Professional  
Installation Service?***

***Contact us at [customer.care@sunjoygroup.com](mailto:customer.care@sunjoygroup.com)***

***Questions? Problèmes? Pièce manquante? Service  
d'installation professionnel?***

***Contactez-nous à [customer.care@sunjoygroup.com](mailto:customer.care@sunjoygroup.com)***



A50400232324



## **⚠️ WARNINGS AND CAUTIONS**

---

### **⚠️ WARNINGS:**

- Paint on this product might peel off if it is hit seriously or used improperly. Use and carry it with care, and apply touch-up paint whenever necessary.
- Some parts may contain sharp edges. Wear protective gloves as necessary.
- CARBON MONOXIDE HAZARD
- Burning charcoal indoors can kill you. It gives off carbon monoxide, which has no odor. NEVER burn charcoal inside vehicles or tents.
- MOST SURFACES ON THIS UNIT ARE HOT WHEN IN USE.
- USE EXTREME CAUTION. KEEP OTHERS AWAY FROM UNIT.
- ALWAYS WEAR PROTECTIVE CLOTHING TO PREVENT INJURY.

### **⚠️ CAUTIONS:**

- Read and follow all instructions before assembly.
- Repeated assembly can weaken the locking ability of the washers. Periodically check all bolted connections on your grill to make sure they are tight and secure. Retain these instructions for future reference.
- Do NOT overtighten any of the nuts as this may damage the threads. Tighten each nut firmly and properly.
- THIS UNIT IS HEAVY! DO NOT assemble without a helper.

## **PREPARATION**

---

Before beginning assembly of product, make sure all parts are present. Compare parts with package contents list and diagram on page 5 to 8. If any part is missing or damaged, do not attempt to assemble the product. Contact customer service for replacement parts.

Tools required for assembly: Wrench (included) and Phillips Screwdriver (not included)

**Warranty: 1 Year**

### **WHAT IS COVER?**

The limited warranty is extended to the original purchaser and applies to material and manufacturer's defect provided the item is maintained with care and used only for personal, residential purposes.

**IMPORTANT**

KEEP THIS INSTRUCTION MANUAL FOR FUTURE REFERENCE.

### **How many people needed for the installation work**

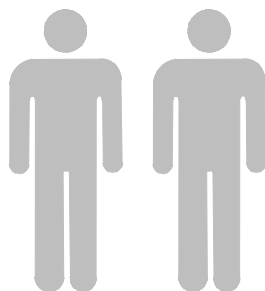



## AVERTISSEMENTS ET MISES EN GARDE

---



### AVERTISSEMENT:

- La peinture de ce produit peut s'écailler si on la cogne fortement ou si on l'utilise de façon inappropriée. Employez-le et déplacez-le avec précaution, et appliquez de la peinture à retoucher dès qu'il le soit nécessaire.
- Certaines pièces peuvent avoir des bords tranchants. Portez des gants de protection s'il est nécessaire.
- RISQUE DE MONOXYDE DE CARBONE
- Brûler du charbon de bois à l'intérieur peut provoquer la mort. Cela dégage du monoxyde de carbone, qui n'a pas d'odeur.  
NE JAMAIS brûler de charbon de bois à l'intérieur de véhicules ou de tentes.
- LA PLUPART DES SURFACES SUR CETTE UNITÉ SONT CHAUDES PENDANT L'EMPLOI.
- SOYEZ EXTRÊMEMENT PRUDENT. MAINTENEZ TOUT LE MONDE À L'ÉCART DE L'APPAREIL.
- PORTEZ TOUJOURS DES VÊTEMENTS DE PROTECTION POUR ÉVITER DES BLESSURES.



### MISES EN GARDE:

- Veuillez lire toutes les instructions avant le montage et les suivre.
- Le montage répétitif peut diminuer la capacité de blocage des rondelles. Vérifiez de temps en temps toutes les connexions boulonnées de votre grill pour vous assurer qu'elles sont serrées fortement et fixées. Gardez ces instructions pour les consulter dans l'avenir.
- NE SERREZ PAS les écrous de trop car vous pourriez abîmer le filetage. Serrez tous les écrous solidement et correctement.
- CETTE UNITÉ EST TRÈS LOURDE! NE L'assemblez PAS sans aide.

## PREPARATION

---

Avant de commencer à assembler le produit, assurez-vous que toutes les pièces sont comprises. Comparez les pièces avec la liste de contenu de l'emballage et le diagramme des pages 5 à 8. S'il manque une pièce ou si elle est abîmée, n'essayez pas d'assembler le produit. Contactez le Service au Client pour des pièces de rechange.

**Garantie: 1 AN**

## CE QUI EST COUVERT PAR LA GARANTIE

La garantie limitée n'est attribuée qu'à l'acheteur d'origine et s'applique aux défauts matériaux et du fabricant à condition que l'article soit entretenu avec soin et utilisé uniquement à des fins personnelles et résidentielles.

**IMPORTANT**

CONSERVEZ CE MANUEL D'INSTRUCTIONS POUR LE CONSULTER DANS L'AVENIR.



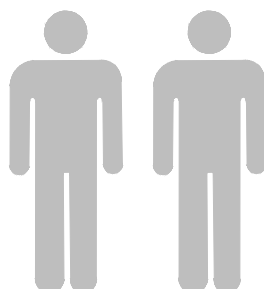



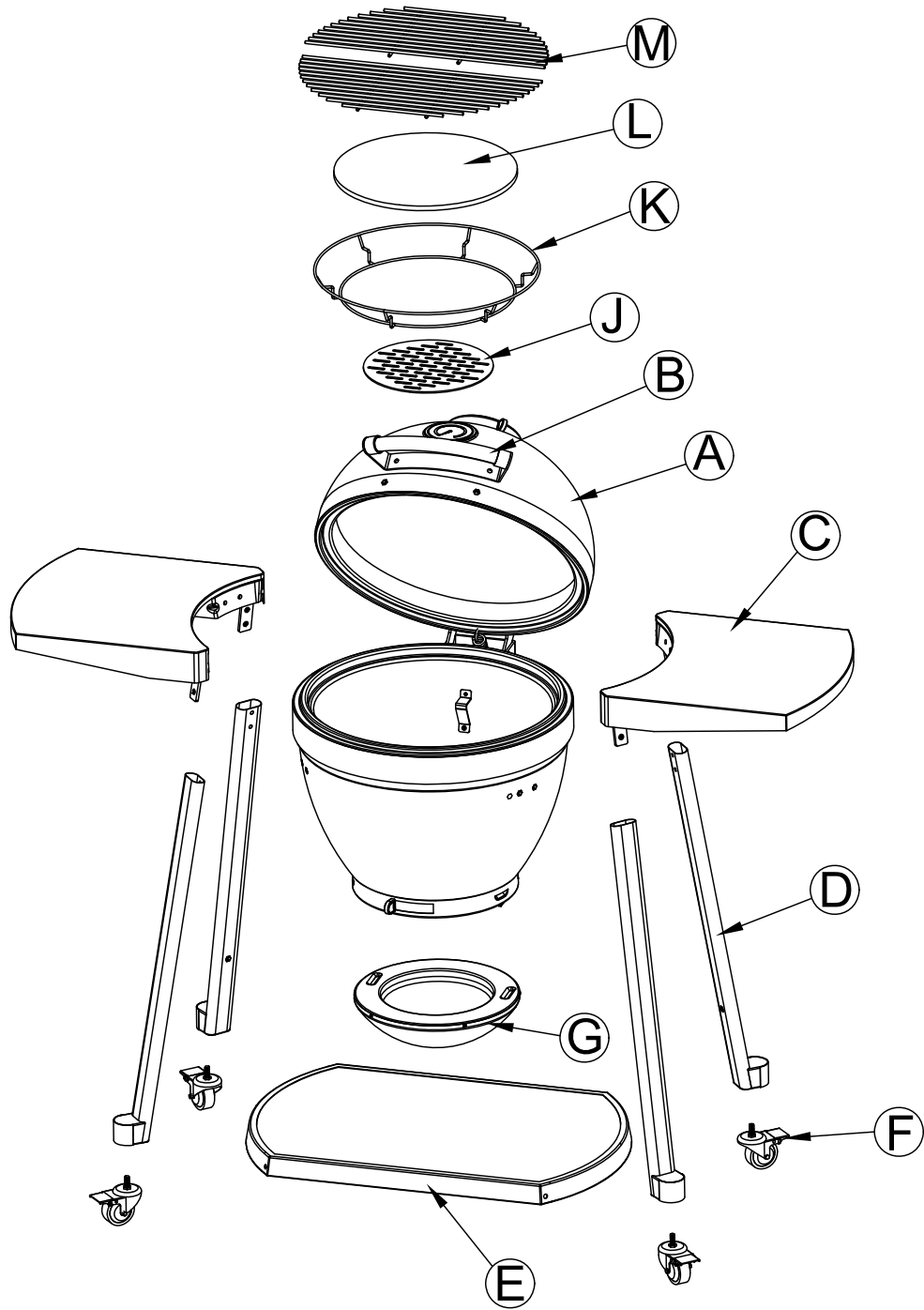

**Combien de personnes seront nécessaires pour le travail d'installation.**



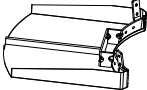

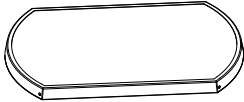

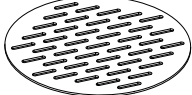

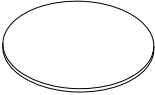
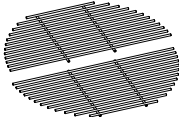
# EXPLODED DRAWING / DIAGRAMME AMPLIFIÉ



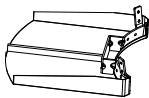

## Parts List

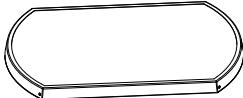
| Label | Part Number  | Description   | Qty | Part Image  |
|-------|--------------|---------------|-----|---|
| A     | P00310013204 | Lid           | 1   |    |
| B     | P00760020601 | Handle        | 1   |    |
| C     | P00230012101 | Shelf         | 2   |    |
| D     | P00540078601 | Foot          | 4   |    |
| E     | P00230012201 | Bottom shelf  | 1   |    |
| F     | P00330006801 | Wheel         | 4   |  |
| G     | P00300002003 | Ash Basin     | 1   |  |
| J     | P00280003901 | Carbon Plate  | 1   |  |
| K     | P00500093401 | Support Frame | 1   |  |
| L     | P00760027801 | Pizza Tray    | 1   |  |
| M     | P00290001801 | Cooking grid  | 1   |  |

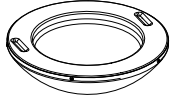
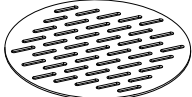
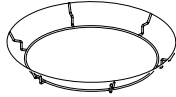
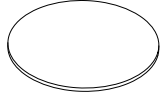
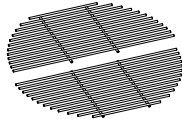
## Liste de Pièces

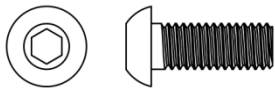
| Étiqueter | Numéro de la pièce | Description          | Quantité | DIAGRAMME DE LA PIÈCE   |
|-----------|--------------------|----------------------|----------|---|
| A         | P00310013204       | couvercle            | 1        |    |
| B         | P00760020601       | Manche               | 1        |    |
| C         | P00230012101       | Étagère              | 2        |    |
| D         | P00540078601       | Le pied              | 4        |    |
| E         | P00230012201       | Étagère inférieure   | 1        |    |
| F         | P00330006801       | Roue                 | 4        |   |
| G         | P00300002003       | Bassin de cendres    | 1        |  |
| J         | P00280003901       | Plaque de carbone    | 1        |  |
| K         | P00500093401       | Structure de support | 1        |  |
| L         | P00760027801       | Plateau à pizza      | 1        |  |
| M         | P00290001801       | Grille de cuisson    | 1        |  |

| Parts List |             |                       |     |   |
|------------|-------------|-----------------------|-----|---|
| Label      | Part Number | Description           | Qty | Part Image  |
| H1         | H010060023  | Bolt M6*16            | 22  |  |
| HW1        | H090030002  | Socket head wrench M6 | 1   |  |
| HW2        | H090010015  | Wrench M10            | 1   |  |

| Liste de Pièces |                    |                  |          |   |
|-----------------|--------------------|------------------|----------|---|
| Étiqueter       | Numéro de la pièce | Description      | Quantité | DIAGRAMME DE LA PIÈCE   |
| H1              | H010060023         | Boulon M6*16     | 22       |  |
| HW1             | H090030002         | Clé à douille M6 | 1        |  |
| HW2             | H090010015         | Clé M10          | 1        |  |

1

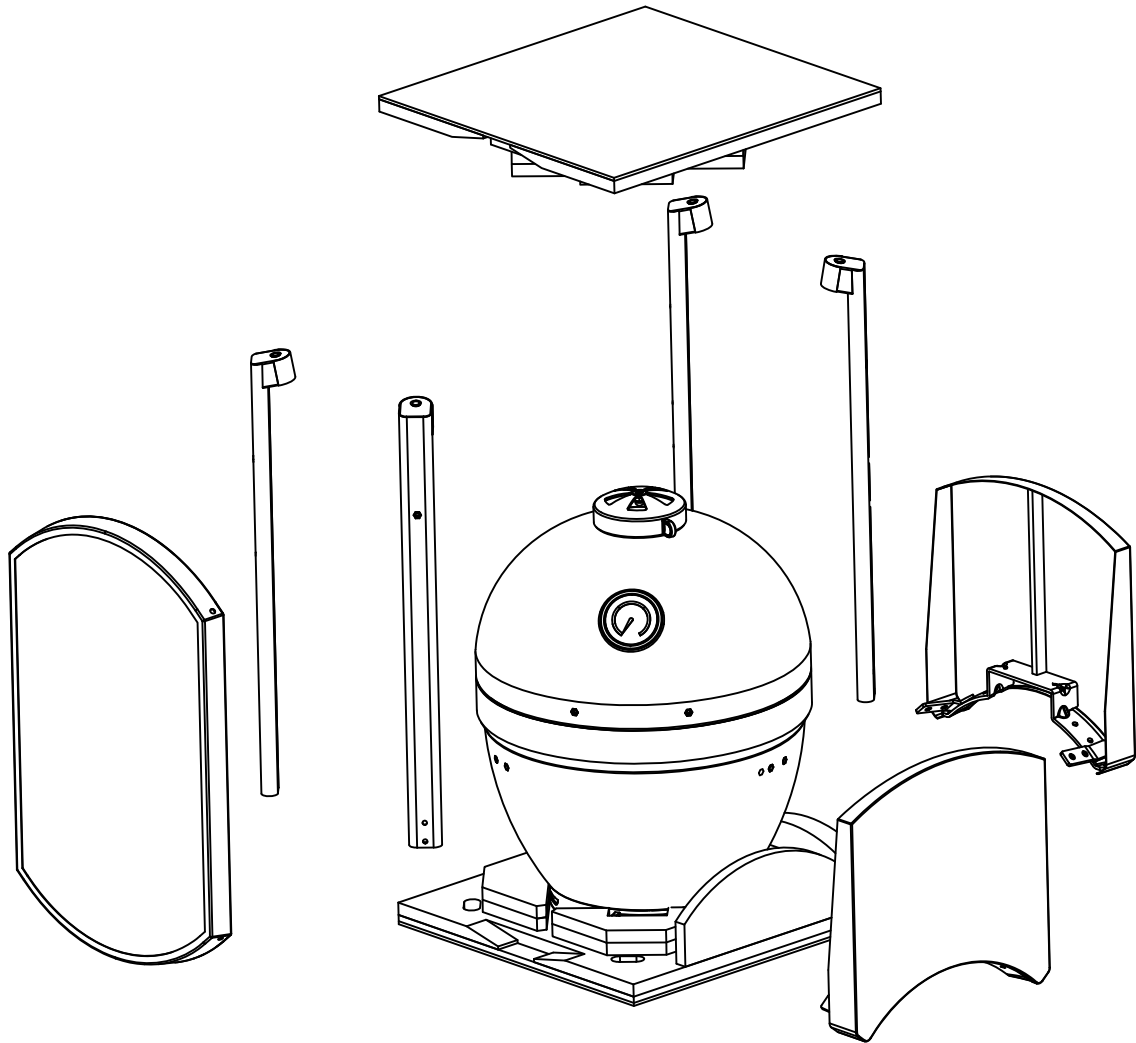



2

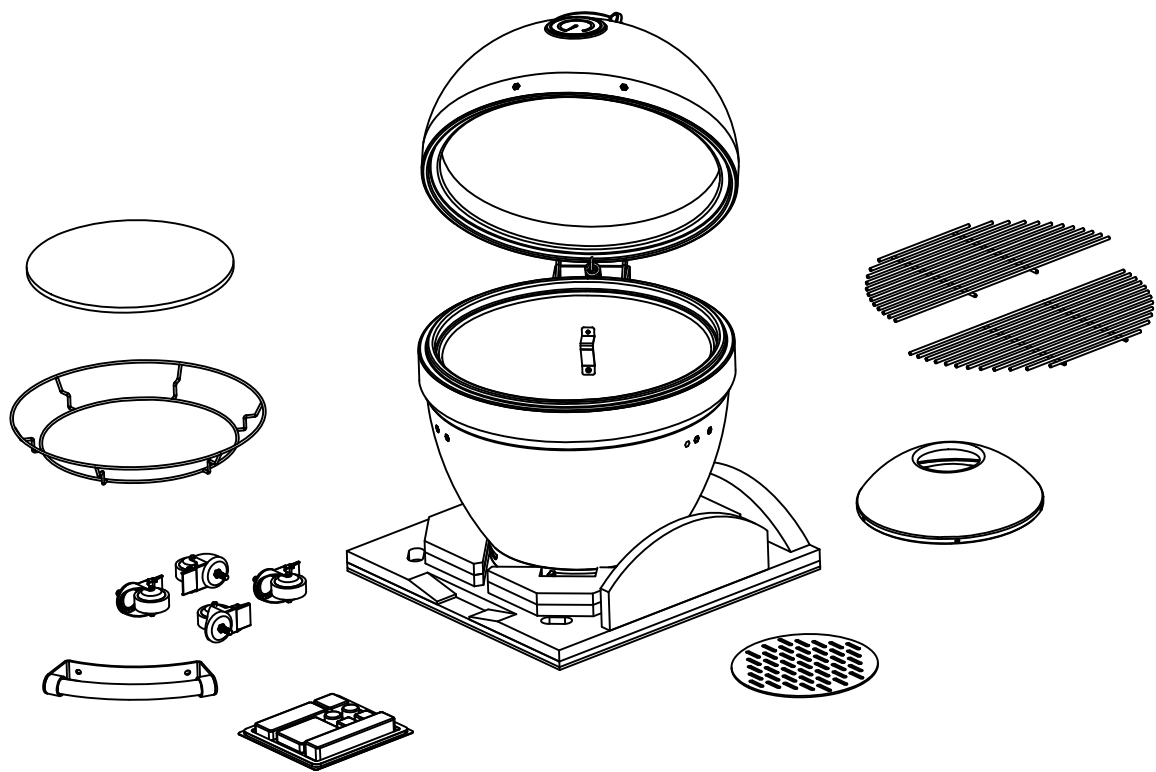

3

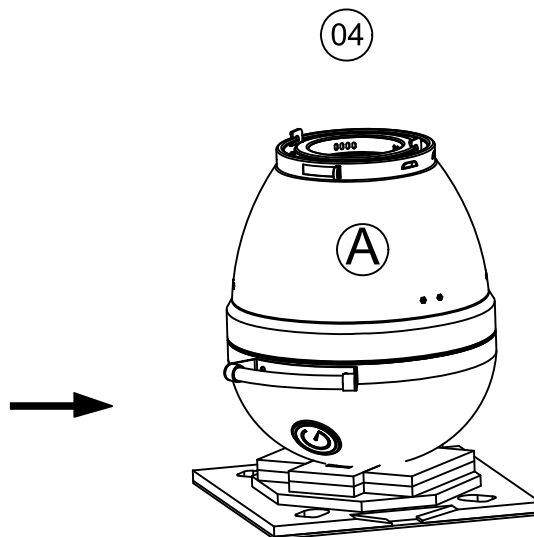
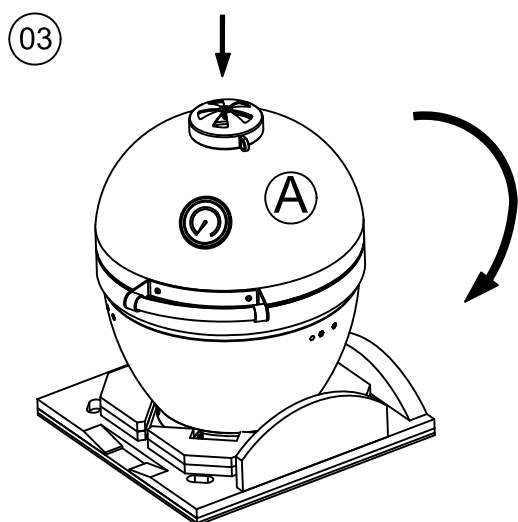
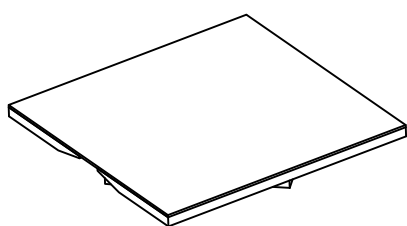
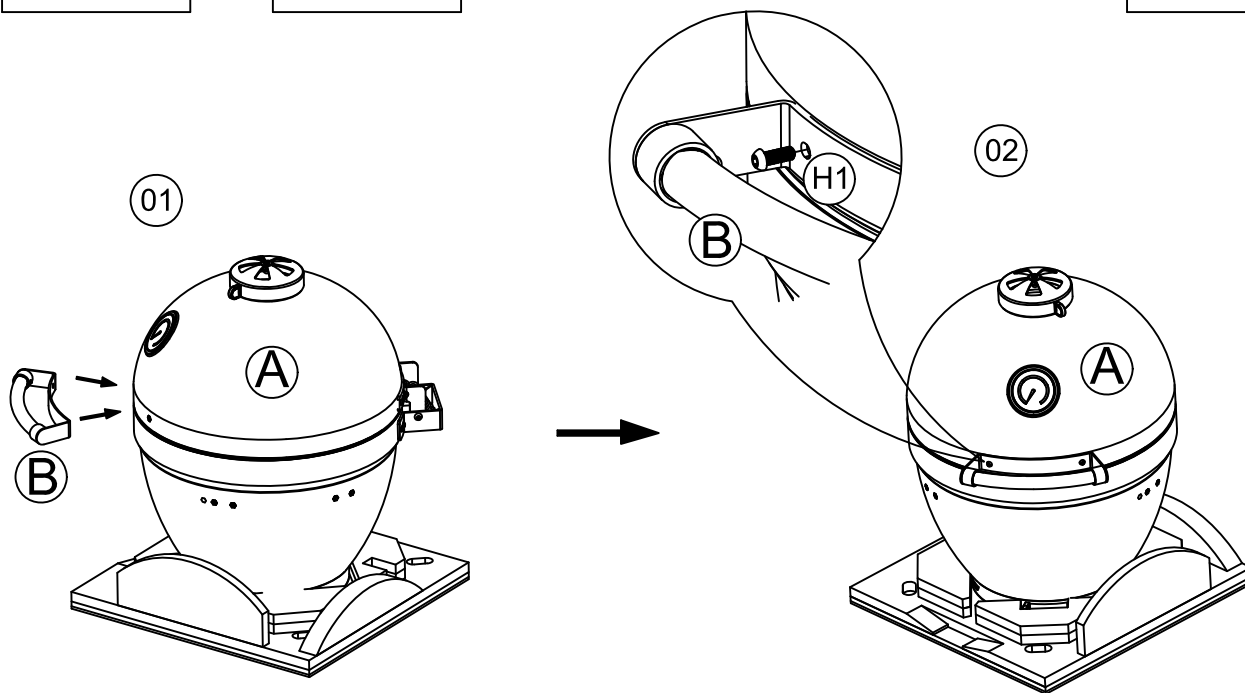
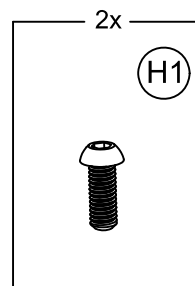
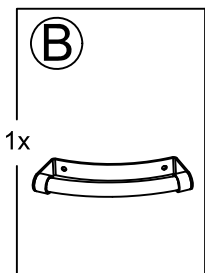
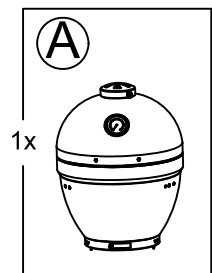

4

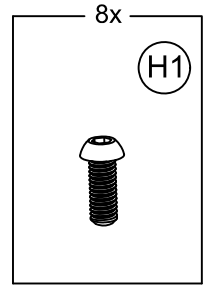
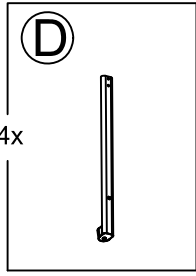
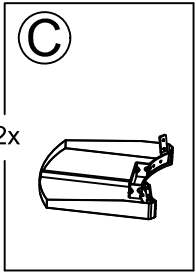

01

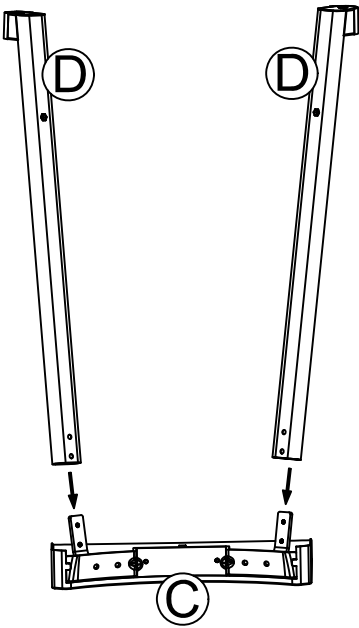

02

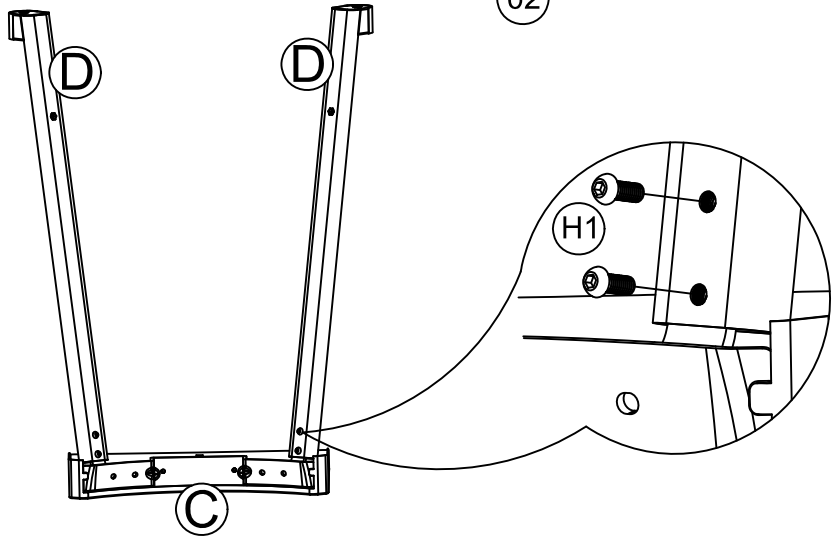

5

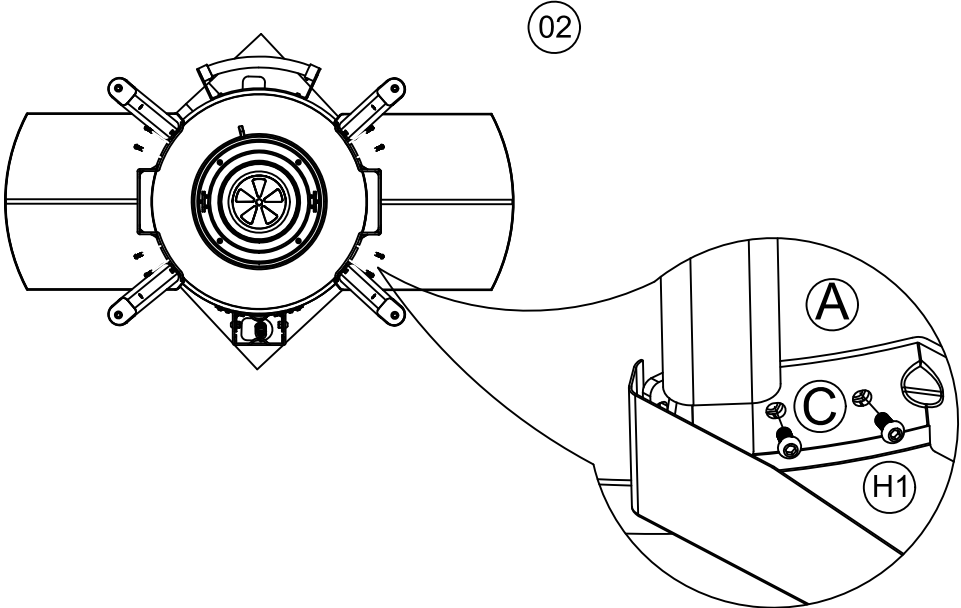
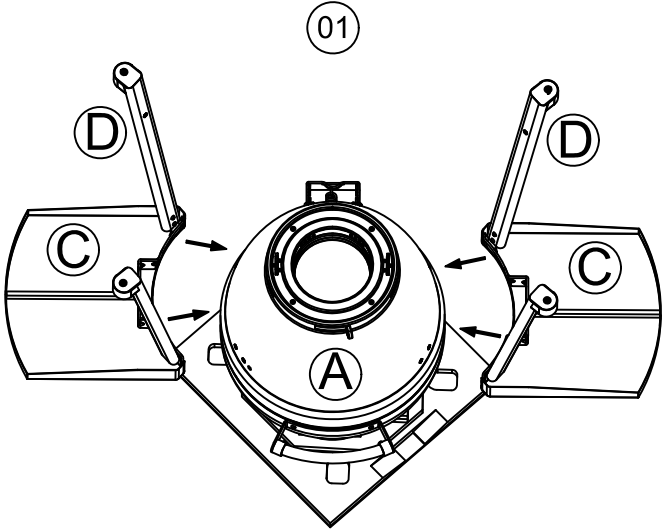
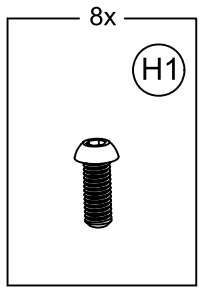

6

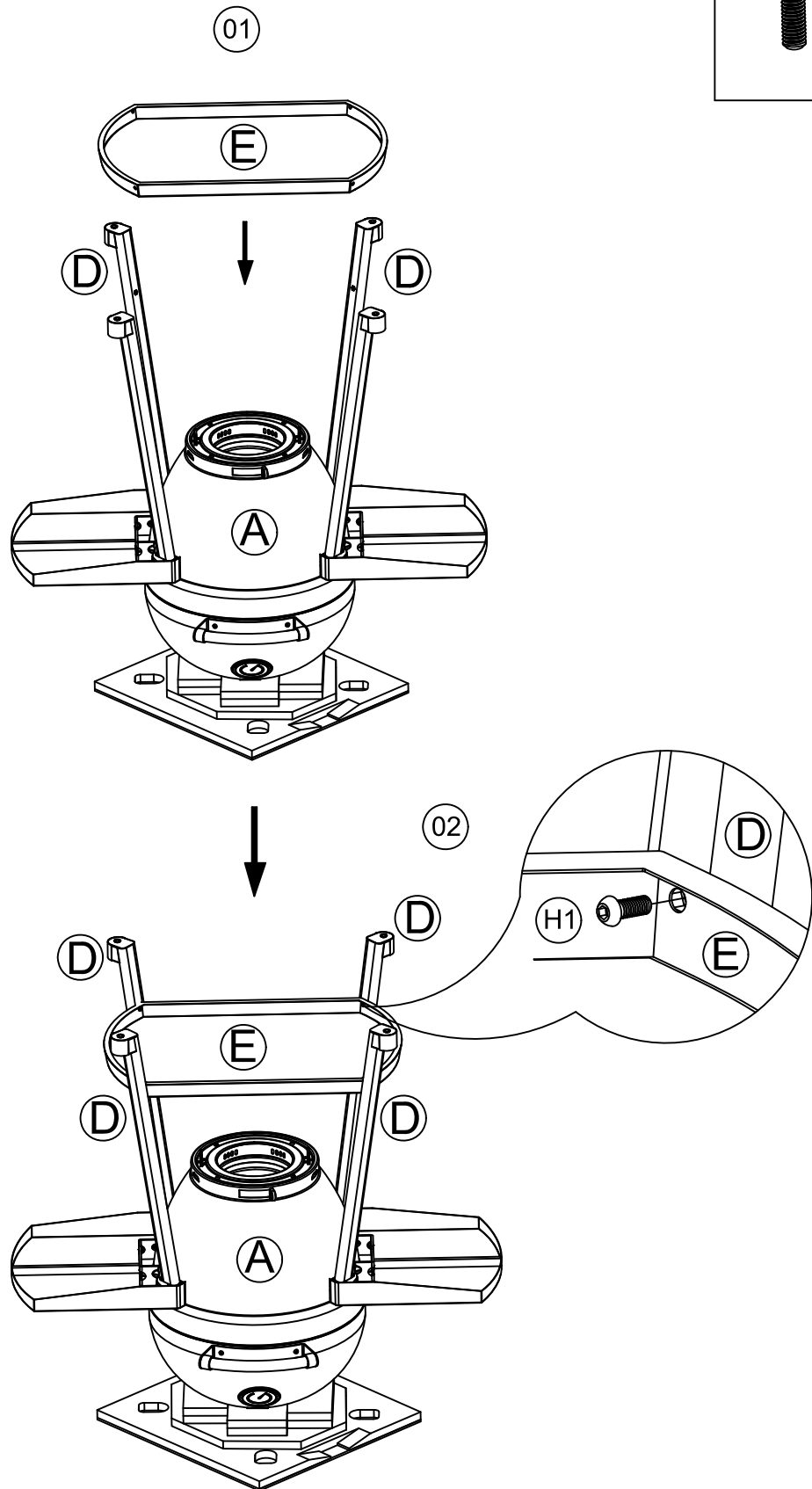
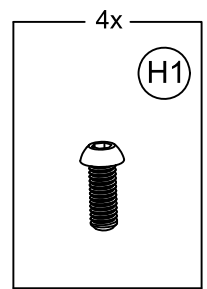
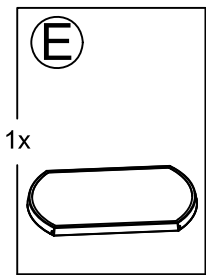

7

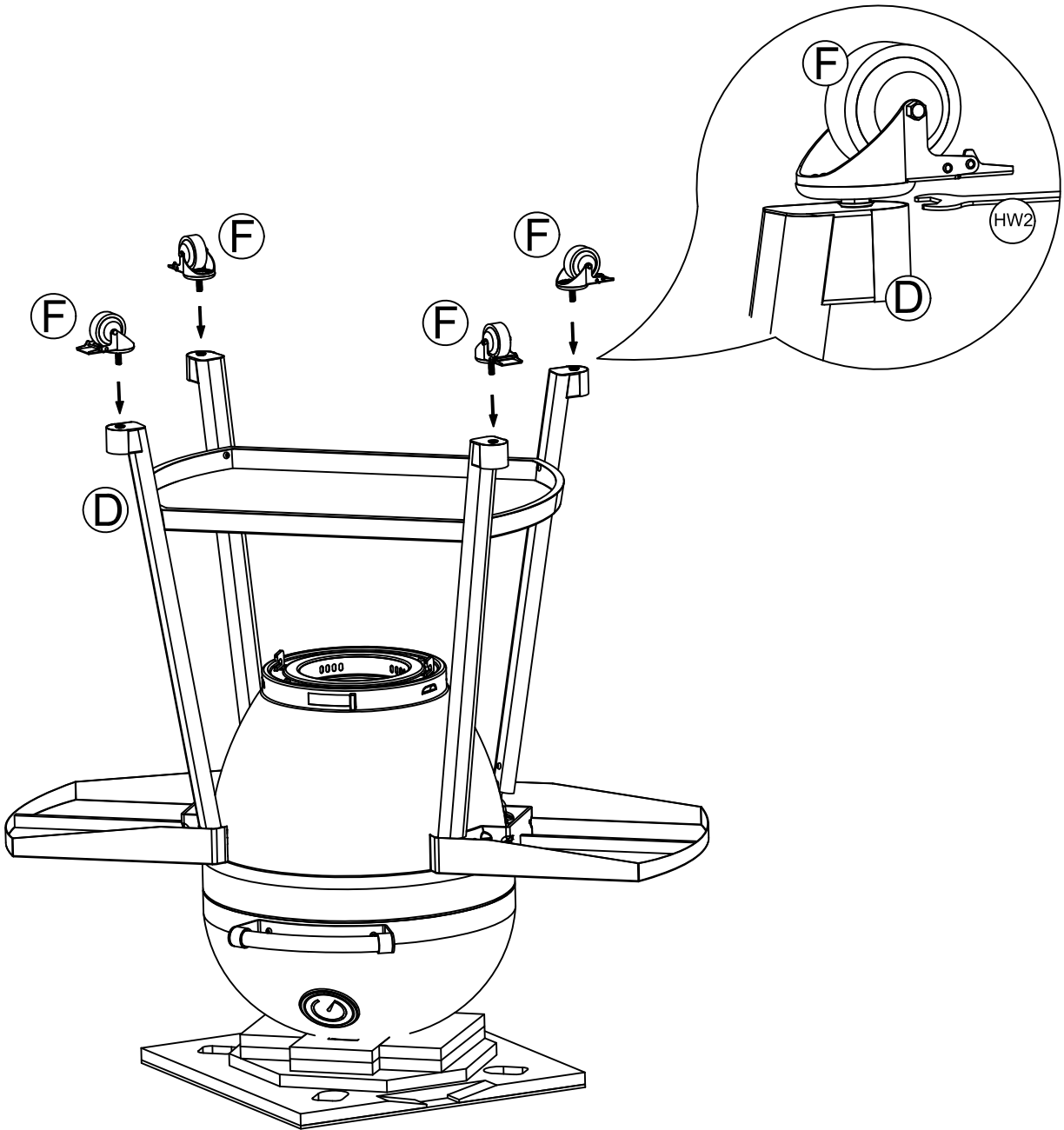
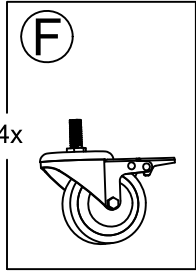

01

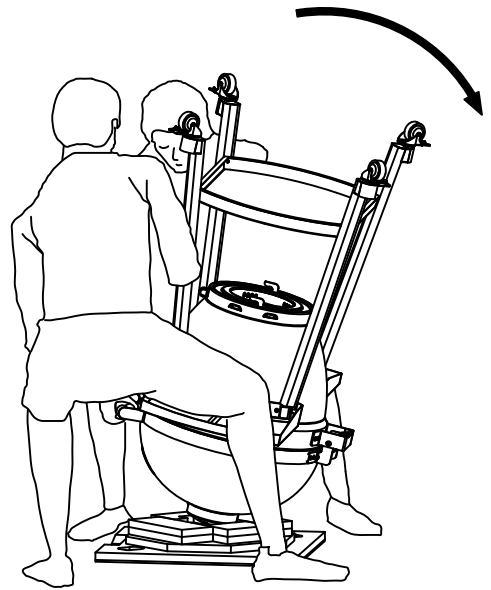
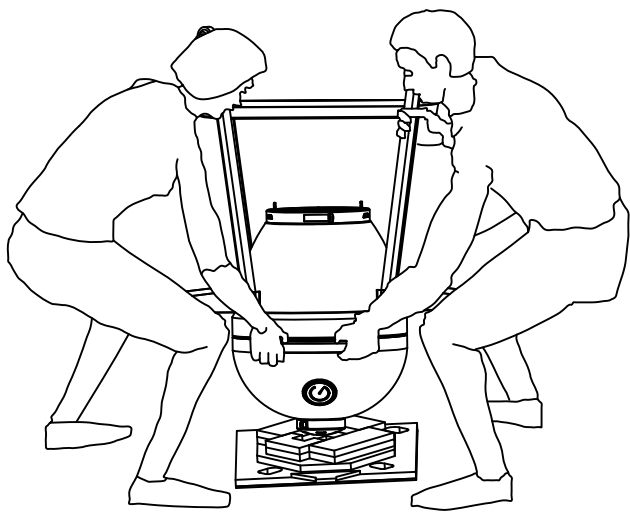

02

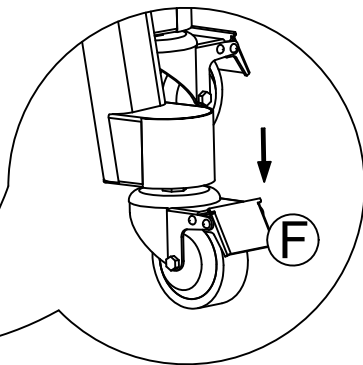
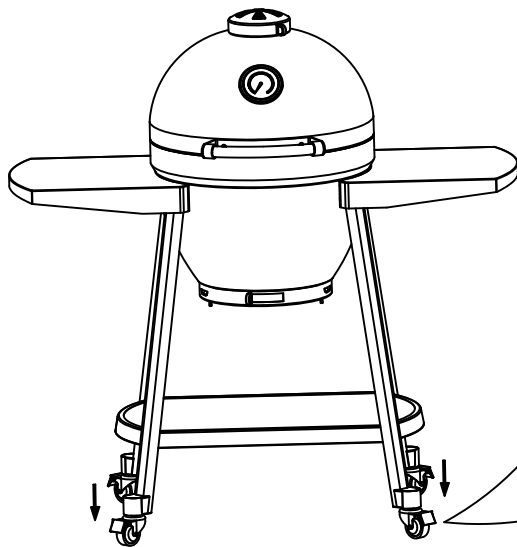

9

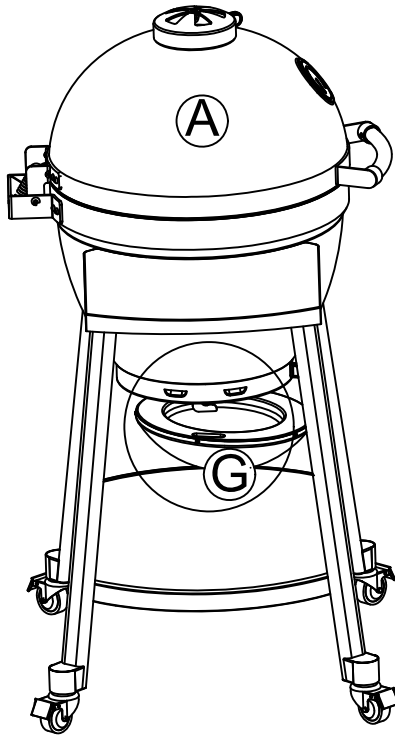
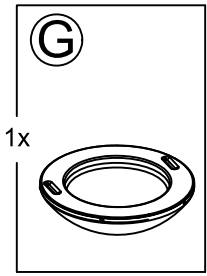

01

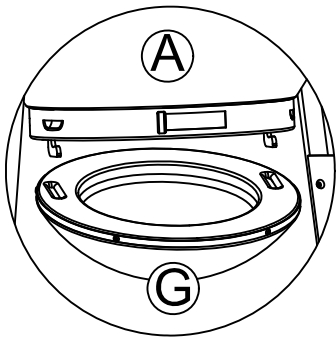

03

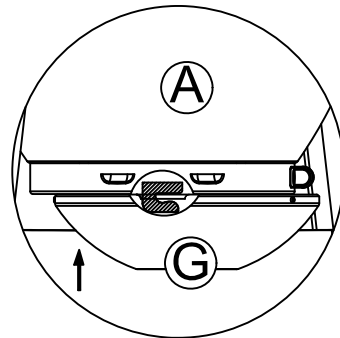

02

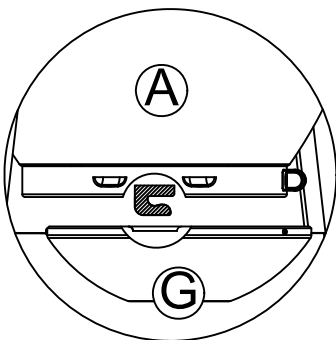

04

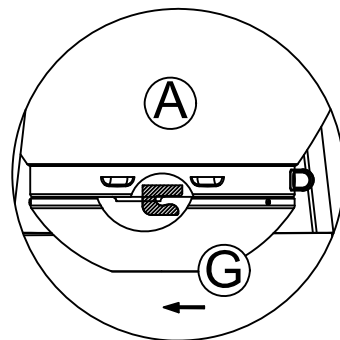



10

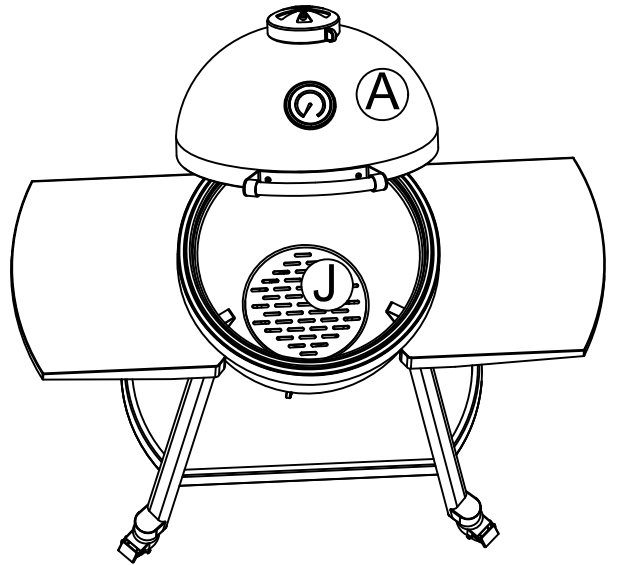
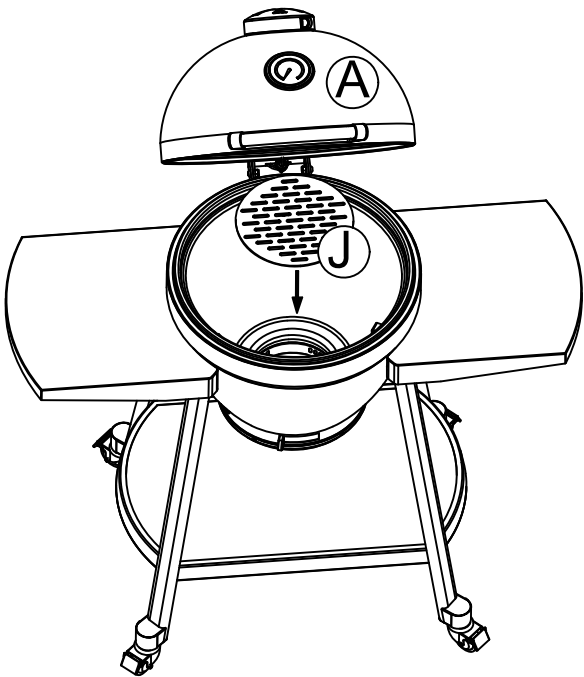
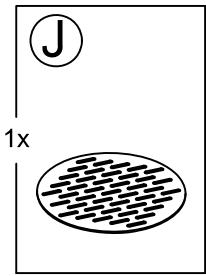

11

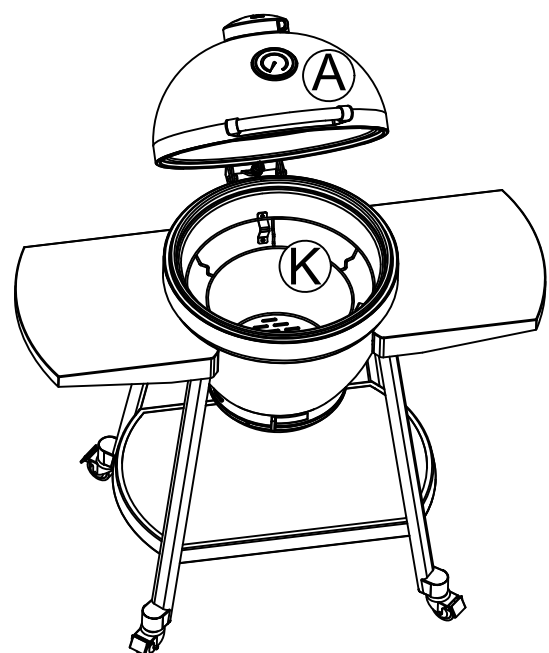
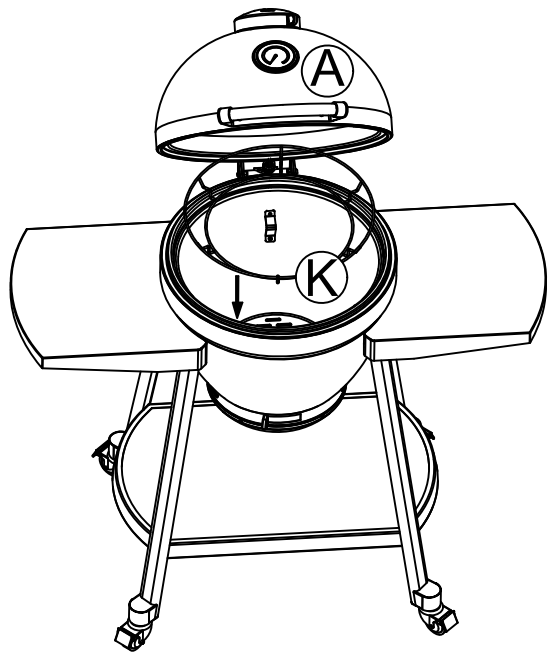
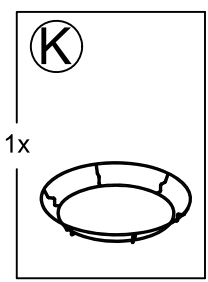

12

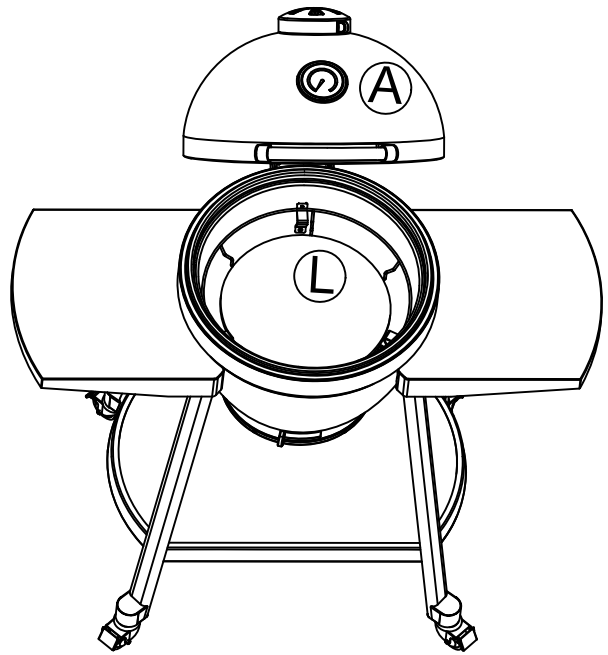
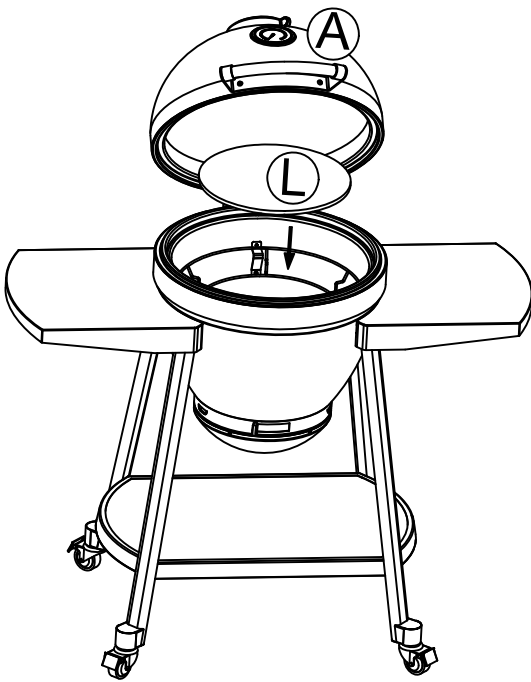
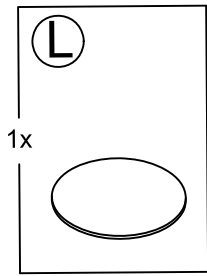

13

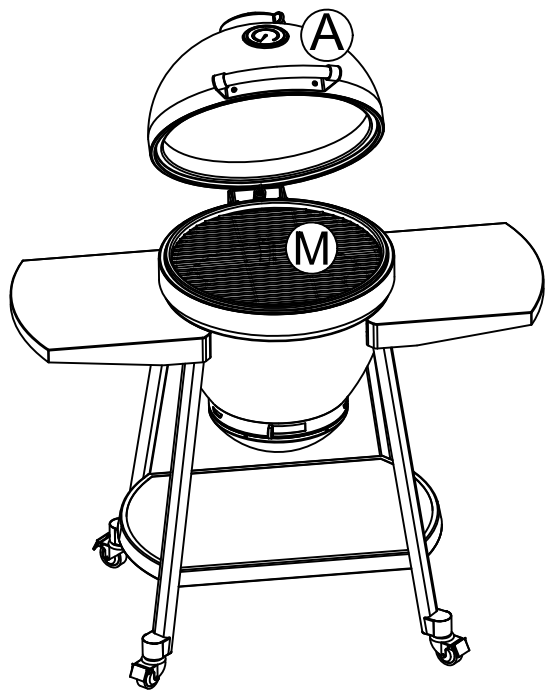
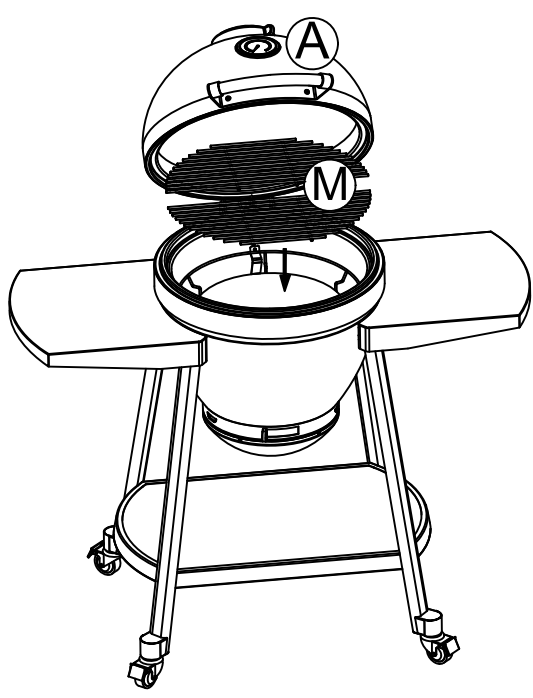
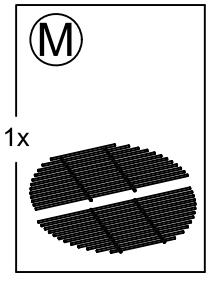

## CARE AND MAINTENANCE

---

- Before cooking with your unit, the following steps should be closely followed.
- Failure to properly follow these steps may damage the finish and/or impart metallic flavors to your first foods.
- Brush all interior surfaces including grates with vegetable cooking oil.
- Charcoal or Wood may be used as the fuel source for grilling, with the fuel source placed and ignited on the ash pan. Do not build the fire too large. We recommend starting a fire with no more than 4 pounds of charcoal (approximately 60 briquettes) and adding more as needed during cooking. After allowing the fire to burn down, place the cooking grate on the unit. Failure to read and follow instructions for lighting charcoal may result in serious personal injury and/or property damage.
- Frequency of cleanup is determined by how often the grill is used. Make sure coals are completely extinguished before cleaning inside of unit. Thoroughly rinse with water and allow to air dry before using again. Wipe out the interior of unit with cloth or paper towel.

## SOIN ET ENTRETIEN

---

- Avant de cuisiner avec votre appareil, suivez scrupuleusement les étapes suivantes.
- Ne pas suivre ces étapes de façon correcte peut abîmer le fini et/ou donner des saveurs métalliques à vos premiers aliments.
- Badigeonnez toutes les surfaces intérieures, y compris les grilles, avec de l'huile de cuisson végétale.
- Le charbon de bois ou le bois peuvent être utilisés comme source de combustible pour les grillades, la source de combustible étant placée et allumée sur le cendrier. Ne faites pas le feu trop fort. Nous vous recommandons d'allumer un feu avec pas plus de 4 livres de charbon de bois (environ 60 briquettes) et d'en ajouter au besoin pendant la cuisson. Après avoir laissé le feu s'éteindre, placez la grille de cuisson sur l'appareil. Ne pas lire et suivre les instructions d'allumage du charbon de bois peut provoquer des blessures graves et/ou des dommages matériels.
- La fréquence de nettoyage est déterminée par la fréquence d'utilisation du grill. Assurez-vous que les charbons sont complètement éteints avant de nettoyer l'intérieur de l'appareil. Rincer abondamment à l'eau et laisser sécher à l'air libre avant de réutiliser. Essuyez l'intérieur de l'appareil avec un chiffon ou une serviette en papier.