



MASSIMO
ELECTRIC



MVR
GOLF CART

OWNERS MANUAL

©MASSIMO ELECTRIC LLC

WELCOME

Thank you for purchasing this vehicle. Before you drive the vehicle, read this Owner's Guide. This guide contains maintenance and operation information. The illustrations can show items that are optional for your vehicle.

You can do most of the service procedures in this guide with common, automotive hand tools. If necessary, contact your service representative for information about how to service the vehicle as shown in the Periodic Service Schedule.

Repair or replacement parts are available from Massimo dealer or Massimo Service Parts Department.

When you contact Massimo about service or parts for your vehicle, the information below is needed.

Vehicle Model: _____

PIN, VIN or Serial Number: _ _ _ _ _

OWNER'S GUIDE

ELECTRIC POWERED VEHICLES

STARTING MODEL YEAR 2020

Attention

- This electric vehicle must be driven by a professionally trained and qualified driver!
- The accelerator pedal and the brake pedal cannot be depressed at the same time, otherwise it will damage the control system and burn out the motor!
- When the vehicle starts, the parking brake must be released, otherwise, it may cause permanent damage to the brake system and damage other parts!
- Modification of the vehicle is not allowed. Modification may affect the performance of the vehicle, the life of the vehicle, or even affect the safety of the vehicle and may violate laws and regulations. Vehicle damage caused by vehicle modification does not belong to the "three guarantees" range!
- Unreasonable installation of electrical equipment on the vehicle, such as alarm devices, car phones, etc., may interfere with the electrical signals of the vehicle control system and affect the performance of the vehicle. When installing such equipment, you should consult our company!
- Due to product improvements, the content of this manual may differ from the actual situation!
- This product is a special motor vehicle used only in the specific area (factory) specified in the "Special Equipment Safety Supervision Regulations"!
- Driving under the influence of alcohol and overloading are strictly prohibited!

NOTES

This vehicle was designed and manufactured in China. The standards and specifications listed in the following text originate in China unless otherwise indicated.

Use Original Equipment Manufacturer (OEM) approved parts to keep the warranty effective.

If you do not correctly do maintenance on the batteries, you will cancel the warranty. Refer to the MAINTENANCE section for instructions on the correct maintenance of the batteries.

BATTERY PROLONGED STORAGE

Batteries discharge over time. The rate of discharge changes according to the ambient temperature, the age and condition of the batteries.

Completely charged batteries will not freeze in winter temperatures unless the temperature is less than -75°F (-60°C).

For winter storage, the batteries must be clean, completely charged and disconnected from any electrical drain.

The battery charger can remain connected to the vehicle to keep a full charge on the batteries while the charger is connected to an active electrical supply. If the power to the electrical supply is disconnected or interrupted, the battery charger will continuously check the charge on the battery pack. A continuous check of the battery pack will pull power from the battery pack and drain the batteries.

The batteries must be checked and charged again as required or at a minimum of 30-day intervals.

Check and keep correct fluid level in all battery cells during the storage period.
Correct fluid level is necessary for maximum battery performance.

BATTERY DISPOSAL

Lead-acid batteries are recyclable. Return discarded batteries to distributor, manufacturer or lead smelter for recycling. For neutralized spills, put residue in acid-resistant containers with absorbent material such as sand. Dispose in accordance with local, state and federal regulations for acid and lead compounds. Contact local or state environmental officials for the disposal information.

SAFETY

GENERAL	1
NOTICES, CAUTIONS, WARNINGS AND DANGERS	1
GENERAL OPERATION	3
MAINTENANCE	4
LABELS AND PICTOGRAMS.....	5

GENERAL SPECIFICATIONS

APPROXIMATE VEHICLE DIMENSIONS	10
--------------------------------------	----

INTRODUCTION

CONTROLS AND INDICATORS.....	25
FEATURES	26
General Information.....	26
Key Switch and Direction Selector.....	26
Battery indicator (if equipped).....	27
Headlight Switch (if equipped)	27
Turn Signal Switch (if equipped).....	27
Accelerator and Brake Pedals.....	27
Horn (if equipped).....	27
Run/Tow Switch.....	27
USB Port (if equipped)	28
12-Volt Power Outlet (if equipped).....	28
Parking Brake	28
Front Seat.....	29
Cup Holder	29
Steering Wheel	29
Rear Seat and Cargo Platform (if equipped)	29
Rear Hand Rail.....	29
Charger Receptacle.....	29
Weather Enclosure (if equipped).....	29
Rear View Mirror (if equipped)	29
DC to DC Converter	29
Battery Compartment	29

TABLE OF CONTENTS

OPERATING PROCEDURES

SERIAL NUMBER LOCATION.....	31
BEFORE INITIAL USE.....	32
PORTABLE CHARGER INSTALLATION	32
HOW TO USE THE CHARGER.....	34
CHARGER MAINTENANCE	34
HOW TO OPERATE THE VEHICLE	35
Direction Selector Operation	36
Accelerator and Brake Pedal Operation	36
Horn (if equipped).....	36
Run/Tow Switch Operation	36
Rear Seat and Cargo Platform Operation (if equipped).....	37
Regenerative Braking	37
Pedal-Up Braking	38
High Pedal Disable Feature	38
STARTING AND DRIVING.....	38
Starting Vehicle On A Hill.....	38
Coasting	38
LABELS AND PICTOGRAMS	38
SUN TOP AND WINDSHIELD (IF EQUIPPED)	39

MAINTENANCE

VEHICLE CLEANING AND CARE.....	40
ENVIRONMENTAL CONCERNS	40
Battery Disposal	41
LIFTING THE VEHICLE	41
WHEELS AND TIRES	42
Tire Repair.....	43
Wheel Installation	43
LIGHT BULB REPLACEMENT	44
Headlight (if equipped)	44
Turn Signal (if equipped).....	44
Taillight/brake (if equipped).....	44

TABLE OF CONTENTS

TRANSPORTING VEHICLE.....	42
Towing.....	42
Hauling.....	43
SERVICE AND MAINTENANCE.....	43
ROUTINE MAINTENANCE.....	44
TIRE INSPECTION.....	44
BRAKES.....	44
REAR AXLE.....	45
Checking the Lubricant Level.....	45
CAPACITIES AND REPLACEMENT PARTS.....	45
HARDWARE.....	45
BATTERY CHARGING AND MAINTENANCE.....	46
Safety.....	46
Battery.....	50
Battery Maintenance.....	50
At Each Charging Cycle.....	50
Monthly.....	50
Electrolyte Level and Water.....	50
Battery Cleaning.....	52
Battery Removal and Installation.....	52
Prolonged Storage.....	53
Battery Charging.....	54
AC Voltage.....	54
Fault Diagnosis.....	54
Leoch Deep Cycle LDC Series Maintenance-free Battery.....	57
PERIODIC SERVICE SCHEDULE.....	57
PERIODIC SERVICE SCHEDULE.....	57
APPENDIX A.....	A
DECLARATION OF CONFORMITY.....	A

Notes:

A large grid of graph paper for taking notes, consisting of 20 columns and 30 rows of small squares.

Read all of SAFETY and this section before attempting any procedure. Pay particular attention to Notices, Cautions, Warnings and Dangers.

SAFETY

GENERAL

For any questions about material in this manual, contact an authorized representative.

Read and understand all labels on the vehicle. Always replace any damaged or missing labels.

Steep hills allow the vehicle to move at faster speeds than normal speeds on a flat surface. To prevent the loss of vehicle control and possible injury, speeds must be controlled to the maximum level ground speed indicated in the GENERAL SPECIFICATIONS section. Apply the brake to control the speed.

If you operate the vehicle above the maximum specified speed, you can damage the drivetrain components. The damage caused by speeds more than the maximum specified can cause a loss of vehicle control, is abusive, and will not be covered under the warranty.

Use caution when you tow the vehicle. Towing the vehicle above the recommended speed can cause personal injury or damage to the vehicle and other property.

If the vehicle is used in a commercial environment, signs must be in position to inform of possible conditions that can be dangerous.

NOTICES, CAUTIONS, WARNINGS AND DANGERS

Read the **NOTICES, CAUTIONS, WARNINGS** and **DANGERS**. The person who services a vehicle needs the mechanical skill and experience to see possible hazardous conditions. Incorrect service or repairs can cause damage to the vehicle or make the vehicle dangerous to operate.

NOTICE

A NOTICE indicates and describes information not related to personal injury.

CAUTION

A CAUTION indicates a dangerous condition that can cause injury that is not life threatening.

WARNING

A WARNING indicates a dangerous condition that can cause death or serious injury.

DANGER

A DANGER indicates a dangerous condition that will cause death or serious injury.

SAFETY

Read all of SAFETY and this section before attempting any procedure. Pay particular attention to Notices, Cautions, Warnings and Dangers.

This manual contains recommended maintenance procedures from the manufacturer. Follow these procedures and fault diagnosis information to get the best service from the product. To decrease the risk of personal injury or property damage, obey all the information in this manual.

WARNING

Never modify the vehicle in any way that will alter the weight distribution of the vehicle, decrease its stability, increase the speed or extend the stopping distance beyond the factory specification. Such modifications can result in serious personal injury or death.

Do not change the vehicle in any manner that changes the weight distribution, decreases stability, increases speed or extends the necessary distance to stop more than the factory specification. Massimo is not responsible for changes that cause the vehicle to be dangerous.

Do not let anyone below the height of 59 inches (150 cm) operate the vehicle.

Read all of SAFETY and this section before attempting any procedure. Pay particular attention to Notices, Cautions, Warnings and Dangers.

GENERAL OPERATION

Read the following warnings before attempting to operate the vehicle:

WARNING

When you leave the vehicle, turn the key to the OFF position and remove the key from the vehicle.

Drive the vehicle only as fast as terrain and conditions allow. Consider the terrain and traffic conditions. Consider environmental conditions that change the terrain and your ability to control the vehicle.

Do not drive fast downhill. Sudden stops or change of direction can cause a loss of control. Use the brake to control the speed of the vehicle when you drive down a slope.

When possible, stay in approved areas. Do not drive on steep slopes.

Always keep feet, legs, hands and arms inside vehicle.

Do not drive on rough terrain.

Before you drive in the reverse direction, make sure the area behind the vehicle is clear.

Make sure the direction selector is in the correct position before you press the accelerator pedal.

Decrease speed before and during turns.

Make sure you completely stop the vehicle before you move the direction selector.

See GENERAL SPECIFICATIONS for the vehicle load and seat capacity.

NOTICE

Read the following text and warnings before you service the vehicle.

Normal use, wear or abuse can cause some components on the vehicle to fail. The manufacturer cannot know all possible component failures or the methods that failures can occur.

A vehicle in need of repair does not function properly and can be dangerous.

Be careful when you service the vehicle. Be aware of your safety and the safety of other people in the area.

Some components are heavy, spring loaded, corrosive, explosive, can cause high amperage or get hot. Battery acid and hydrogen gas can cause injury. Do not put your hands, face, feet or body in a location that can expose them to injury if an unexpected situation occurs.

Always use the correct tools shown in the tool list and wear safety equipment.

WARNING

Remove all jewelry before you service the vehicle.

Do not allow loose clothing or hair to contact the moving parts.

Do not touch the hot objects.

SAFETY

Read all of SAFETY and this section before attempting any procedure. Pay particular attention to Notices, Cautions, Warnings and Dangers.



When you service the vehicle, always wear eye protection. Be careful when you do work around batteries or you use solvents or compressed air.

ALWAYS:

- Use the vehicle in a responsible manner and keep the vehicle in safe condition for operation.
- Read and obey all warnings and operation instruction labels on the vehicle.
- Follow all safety rules in the area where the vehicle is operated.
- When there is a risk of lightning, leave the vehicle and look for a safe location to wait until the lightning has stopped.
- Drive the vehicle only as fast as terrain and conditions allow.
- Apply the brake to control speed on steep grades.
- Keep enough distance between vehicles.
- Decrease speed in wet areas.
- Be careful when you make sharp turns, or turns you are not familiar with.
- Be careful when you drive on loose terrain.
- Be careful when you operate the vehicle around people.

MAINTENANCE

ALWAYS:

- Replace damaged or missing warning, caution or information labels.
- Service the vehicle according to the periodic service schedule in this manual.
- Make sure that approved and qualified personnel do all repairs.
- Follow the manufacturer's maintenance procedures.
- Use insulated tools within the battery area to prevent sparks or battery explosion.
- Use specified replacement parts. DO NOT use replacement parts of less quality.
- Use recommended tools.
- Make sure that tools and procedures not specified by the manufacturer will not be a safety risk to personnel or operation of the vehicle.
- Use wheel chocks and support vehicle with jack stands. NEVER get below a vehicle that is supported by a jack. Lift the vehicle according to the manufacturer's instructions.
- Make sure you service the vehicle in an area away from open flame or sparks.
- Know that a vehicle in need of repair does not operate correctly and can be dangerous to operate.
- Test drive the vehicle after any repairs or maintenance in a safe area that is free of both vehicular and pedestrian traffic.
- Keep complete records of the maintenance history of the vehicle.

Read all of SAFETY and this section before attempting any procedure. Pay particular attention to Notices, Cautions, Warnings and Dangers.

LABELS AND PICTOGRAMS



SAFETY

Read all of SAFETY and this section before attempting any procedure. Pay particular attention to Notices, Cautions, Warnings and Dangers.



⚠ WARNING ⚠

Keep entire body inside car.



⚠ WARNING ⚠

Windshields do not provide protection from golf balls or other flying objects.



⚠ Precautions for Battery maintenance

- **Battery maintenance:**
 1. Battery water must be checked regularly. Do not allow the battery to dry. Please add the battery water and keep the liquid level above the plate 10-15mm;
 2. For the vehicles that long-term placement must be fully charged, And make sure to charge and discharge once a month. Towing Precautions;



⚠ WARNING

 <p>When the battery is in the case of charging or not charging, the explosive gas will be released. Keep it ventilated, away from sparks, fireworks and cigarettes. When operating the battery, please protect the eyes.</p>	 <p>Sulfuric acid in the battery can damage the eyes, skin, and clothing. Forbid flipping the battery. Keep the vent cover tight and level. Rinse immediately with water and see a doctor in case of injury.</p>	 <p>Short circuit can cause a fire. Forbid connecting the positive and negative terminals of the battery together.</p>
--	---	---

SAFETY

Read all of SAFETY and this section before attempting any procedure. Pay particular attention to Notices, Cautions, Warnings and Dangers.

WARNING

Notice:

- Please operate properly according to Manual.
- Please do not touch inner jack of Charge Socket.
- Please do not spatter water inside.



SAFETY

Read all of SAFETY and this section before attempting any procedure. Pay particular attention to Notices, Cautions, Warnings and Dangers.

Notes:

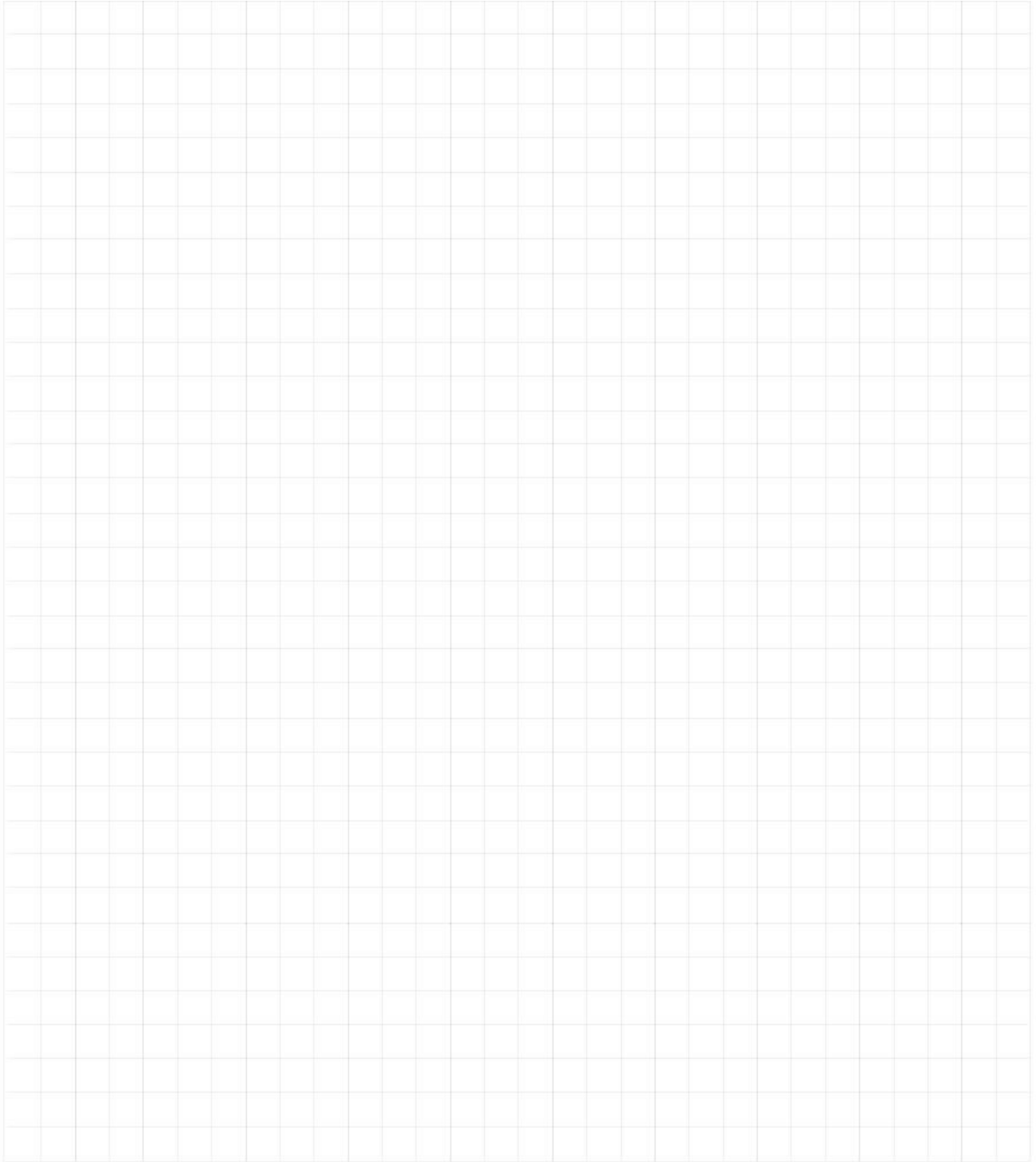
A large grid of graph paper for taking notes, consisting of 20 columns and 30 rows of small squares.

GENERAL SPECIFICATIONS



MODEL: MVR CARGO



PRODUCT SPECIFICATION

CONFIGURATION HIGHLIGHTS

- MOTOR** AC 48V 4 KW / AC 48V 5KW
- Charger:** 48V18A Delta Q On Board charger / Smart Charger 48V25A
- Electrical System:** Leoch Brand, AGM Battery 8V 180Ah/3HR * 6 PCS
- Drive Train:** Direct motor shaft connected to transaxle pinion shaft
- Brakes:** Rear Drum Brake or four wheels hydraulic brake
- Body Protection:** PP Plastic Molded Material

Technical Specification

Dimensions	
Overall Length	102.8in (261 cm)
Overall Width	49.6 in (126cm)
Overall Height (NO Canopy)	N/A
Overall Height (With Canopy)	77.6in (197 cm)
Wheel Base	65.7in (167 cm)
Front Wheel Track	37.4 in (950 mm)
Rear Wheel Track	39.4in (100 cm)
Gnd Clearance @ Differential	6.7 in (17cm)
Vehicle Power	
Power Source	48 Volts
Motor Type	AC
Horsepower (kW)	AC 4 KW / AC 5 KW
Electrical System	48 Volt
Batteries (Qty, Type)	6, 8 Volt Deep Cycle
Key	YES
Speed Controller	DC 1268 400A / AC 1232SER 400A/ 1234SE 450A
Drive Train	Motor Shaft Direct Drive
Transaxle	N/A
Gear Selection	Dash Mounted Forward-Neutral-Reverse
Rear Axle Ratio	12.31:1 / 14.2 :1

Performance	
Seating Capacity	2 Person
Dry Weight	661.4.lb(300 kg) (Without Batteries)
Curb Weight	1190.5lb (540kg)
Vehicle load capacity	793 lb (360 kg)
Minimum turning radius	10.1ft (3.1m)
Intersecting Aisle Clearance	N/A
Maximum speed (Level Ground)	15.53 mph (25 km/h)
Towing Capacity	N/A
Steering & Suspension	
Steering	Rack and pinion
Front Suspension	McPherson independent suspension
Rear Suspension	Trail Arm Suspension
Service Brake	Mechanical brake
Parking Brake	Mechanical foot parking
Front Tires	22*10-10 / 22*11-12
Rear Tires	22*10-10 / 22*11-12
Body & Chassis	
Frame	Welded Steel. powder coat and electrophoresis
Body & Finish	Injection molding
Standard Color	Color according to order requirements

Some items shown may be optional equipment

Some items shown may be optional equipment

GENERAL SPECIFICATIONS



MODEL: MVR2X



PRODUCT SPECIFICATION

CONFIGURATION HIGHLIGHTS

- MOTOR** AC 48V 4 KW / AC 48V5KW
- Charger:** 48V18A Delta Q On Board charger / Smart Charger 48V25A
- Electrical System:** Leoch Brand, AGM Battery 8V 180Ah/3HR * 6 PCS
- Drive Train:** Direct motor shaft connected to transaxle pinion shaft
- Brakes:** Rear Drum Brake or four wheels hydraulic brake
- Body Protection:** PP Plastic Molded Material

Technical Specification

Dimensions		Performance	
Overall Length	124 in (3160 mm)	Seating Capacity	4 Person
Overall Width	49.6 in (1260 mm)	Dry Weight	837.76 lb(380 kg) (Without Batteries)
Overall Height (NO Canopy)	N/A	Curb Weight	1336.87 lb (620kg)
Overall Height (With Canopy)	81 in (2050 mm)	Vehicle load capacity	794 lb (360 kg)
Wheel Base	65.74 in (1670 mm)	Minimum turning radius	10.1ft (3.1m)
Front Wheel Track		Intersecting Aisle Clearance	N/A
	37.4 in (950 mm)		
Rear Wheel Track	39 in (1000 mm)	Maximum speed (Level Ground)	15.53 mph (25 km/h)
Ground Clearance @ Differential	6.7 in (170 mm)	Towing Capacity	N/A
Vehicle Power		Steering & Suspension	
Power Source	48 Volts	Steering	Rack and pinion
Motor Type	AC	Front Suspension	McPherson independent suspension
Horsepower (kW)	AC 4 KW / AC 5 KW	Rear Suspension	Trail Arm Suspension
Electrical System	48 Volt	Service Brake	Mechanical brake // Hydraulic brake
Batteries (Qty, Type)	6, 8 Volt Deep Cycle	Parking Brake	Mechanical foot parking
Key	YES	Front Tires	22*10-10 // 22*11-12
	AC 1232SER400A// AC 1234SE 450A		
Speed Controller		Rear Tires	22*10-10 // 22*11-12
Drive Train		Body & Chassis	
Drive Train	Motor Shaft Direct Drive	Frame	Welded Steel. powder coat and electrophoresis
Transaxle	N/A	Body & Finish	Injection molding
Gear Selection	Dash Mounted Forward-Neutral-Reverse	Standard Color	Color according to order requirements
Rear Axle Ratio	12.31:1 / 14.2: 1		

Some items shown may be optional equipment

GENERAL SPECIFICATIONS

Read all of SAFETY and this section before attempting any procedure. Pay particular attention to Notices, Cautions, Warnings and Dangers.

Notes:

A large grid of graph paper for taking notes, consisting of 20 columns and 30 rows of small squares.

INTRODUCTION

Read all of SAFETY and this section before attempting any procedure. Pay particular attention to Notices, Cautions, Warnings and Dangers.

INTRODUCTION

CONTROLS AND INDICATORS

Vehicle controls and indicators consists of: (Figure 1)

1. Gear Switch button (DS-A2-2 L6e Model has Three Postion, D N R)
2. Speedometers
3. Speedometers Cover
4. Headlight Switches Button
5. Hazard Lights Switch Button
6. USB Port as power supply
7. Ignition Key Switch
8. Mechanical Parking Pedal
9. Brake Pedal
10. Accelerator Pedal
11. Tow Switch & Curtis Controller Connector
12. DU-CA500 Model Rear Cargo bed Up and Down Control button
13. Windshield Wiper Spray control button
14. Hydraulic brake system Brake Pedal
15. Hydraulic brake system Accelerator Pedal
16. Hydraulic brake system Foot Parking pedal

Figure 1 Vehicle controls, features and indicators

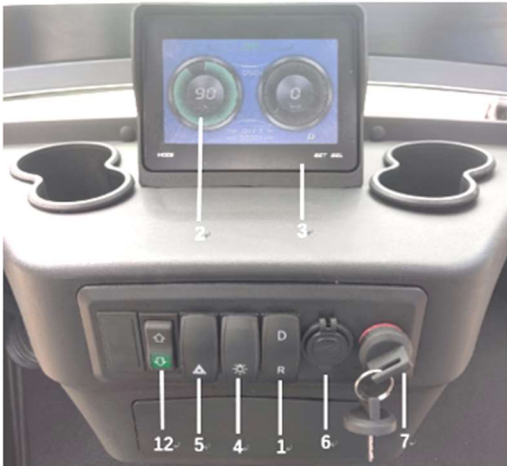

DU-CA500 & All Standard
Massimo Series Golf carts

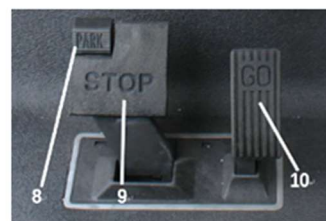

Rear Mechanical Drum
Brake Pedal

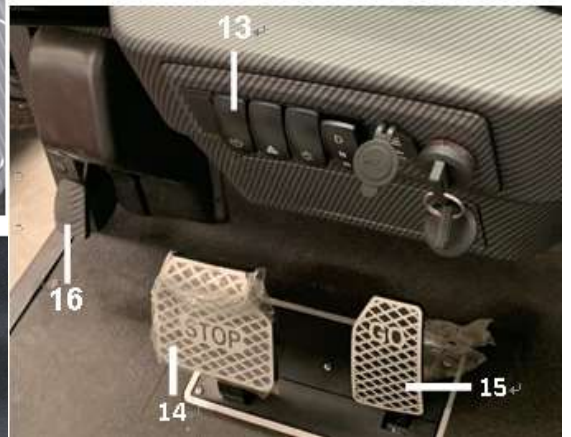

DS-A2-2 L6e Street legal carts Dashboard
with pedal

Read all of SAFETY and this section before attempting any procedure. Pay particular attention to Notices, Cautions, Warnings and Dangers.

FEATURES

General Information

NOTICE

If the vehicle has accessories that were installed at the factory, some accessories continue to operate with the key switch in the OFF position.



CAUTION

ALL accessories that do NOT use the accessory wiring harness MUST be connected to the DC to DC converter to pull from the full 48-Volt battery pack.

A DC to DC converter is necessary for the accessories that need voltage different from 48 volts to operate correctly.

Accessories, including a DC to DC converter, that are connected to this vehicle and do not use the accessory wire harness must be connected across the entire 48-volt battery pack. To correctly connect a 48-volt accessory, connect one wire to the most positive battery pack terminal and the second wire to the most negative battery pack terminal as shown (Figure 2).

If an accessory requires voltage different than 48 volts a DC to DC converter must be used to change the voltage to the correct amount. A DC to DC converter is available for purchase from Massimo Service Parts. The Operational Performance Guarantee of 2 rounds per day is void if non-factory accessories that use more than 1 Amp/Hour of energy per round are installed on the vehicle.

Key Switch and Direction Selector



CAUTION

To decrease the risk of component damage, stop the vehicle before you move the key switch or the direction selector.



WARNING

To prevent the loss of control, do not move the direction selector while the vehicle is in motion. If you move the selector, the vehicle speed will immediately decrease and a warning device activates.

The key Switch and Direction Selector is located on the dash panel. The key switch or direction selector enables the electrical system of the vehicle to be turned ON or OFF by turning the key. It also functions as the direction selector and allows the operator to select F (forward) or R (reverse).

When the direction selector is moved to the R position, the reverse warning buzzer activates.

When the vehicle is without an operator, the key switch must be turned to the OFF position and removed, to prevent accidental movement of the vehicle.

Attach Negative Wire from The Accessory to (-) Battery Terminal

Attach Power Wire from The Accessory to (+) Battery Terminal

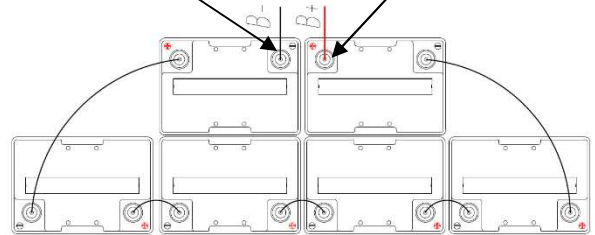

Figure 2 Accessory Wires to Battery Pack Attachment

INTRODUCTION

Read all of SAFETY and this section before attempting any procedure. Pay particular attention to Notices, Cautions, Warnings and Dangers.

Battery indicator (if equipped)

The battery indicator is on the dashboard.

The charge gauge identifies the remaining charge of the batteries in the battery pack. From top to bottom, the battery power is getting less and less.

Headlight Switch (if equipped)

If the vehicle has headlights, the headlight switch is located on the dash panel

Turn Signal Switch (if equipped)

The turn signal switch is on the steering column and controls the operation of the right and left turn signal lights.

Accelerator and Brake Pedals



Accidental movement of the accelerator pedal can cause the vehicle to move suddenly and cause severe injury or death.

When the key is on the position of the  , When the forward/backward switch is in the FWD or REV position, and when you press the accelerator pedal (10 or 15), the motor starts and the vehicle will move in the direction indicated by the forward/backward switch. This vehicle is equipped with motor brake, when the accelerator pedal is released, the motor will stop. To stop the vehicle quickly, press the brake pedal (9 or 14) (Figure 1).

Horn button (if equipped)

The horn button is on the left side of the steering wheel. Press the button to activate the horn.

Tow switch

On the right side under the seat pop (Figure 3)

NOTICE

Before starting the vehicle, please check whether the tow switch is in the No State. The cart will not be able to move, please turn off the tow switch when you will not start the vehicle for a long time.

The DS-A2-2 I6e model, need to sit on the driver seat, before switch on the ignition key, otherwise, the carts cannot have power,



Figure 3 Tow Switch



Parking pedal

This vehicle is equipped with a mechanical parking brake (2) (Figure 4). The parking pedal has three positions. When the vehicle stops, please depress the parking pedal to the third position, and turn the key switch to the third position and pull it out. The key can be left. When starting the vehicle, please turn the key switch to the time, depress the accelerator pedal (4) (Figure 4), the parking pedal (2) (Figure 4) and the brake pedal (3) (Figure 4) will automatically bounce off, and then move forward and backward. When the switch is pressed to FWD or REV, the vehicle can run in the selected direction.



Figure 4 Parking pedal

Hydraulic pedal

This vehicle is equipped with a mechanical brake pedal (Figure 5). When the vehicle is stopped, please depress the parking pedal(5), turn the key switch to  , and then remove the key before leaving. When starting the vehicle, please turn the key switch to  , press the parking pedal(5), and the parking pedal(5) will automatically reset. When the switch is pressed to FWD or REV, the vehicle can run in the selected direction.

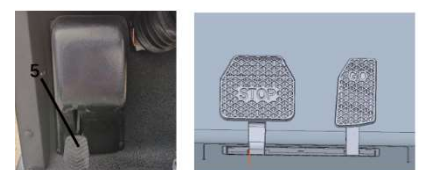

Figure 5 Hydraulic pedal

Read all of SAFETY and this section before attempting any procedure. Pay particular attention to Notices, Cautions, Warnings and Dangers.

DANGER

Before trying to tow or start the vehicle, please make sure that the parking pedal is in the released state, otherwise the brake system and control will be damaged.

System, burn out the motor. The parking pedal has three gears. When the vehicle is stopped on a flat road or on a slope, please step on the parking pedal to

The third gear is to ensure that the parking function of the vehicle is in effect, otherwise the vehicle will move and endanger the safety of life and property. Simultaneously

It should be noted that the ramp where the vehicle stops should not be greater than the ramp that the vehicle can stop, otherwise the side parking effect will also be invalid.

The safety of the passengers' lives and property is endangered at times, because the parking pedal is not stepped on to the third gear when parking and stopping on a ramp greater than the prescribed

Or accidents caused by not stepping on the parking pedal, Massimo company will not bear responsibility!

Front Seat

The front seat (1 & 2) is for two people, one person on each side of the seat (Figure 6).

Cup Holder

The vehicle has two cup holders (3) for the driver and passenger (Figure 6).

Steering Wheel

The steering wheel (4) controls the direction of vehicle travel (Figure 6).

Rear Seat and Cargo Platform (if equipped)

Rear passengers must stay in the seat and hold both the hand rail and rear handle while the vehicle is in motion.

Do not allow passengers to ride on the cargo platform. A sudden move or stop can cause severe injury or death to passengers on the cargo platform.

The vehicle has a feature that functions as a rear seat or a cargo platform.

When in the upright position, it is a rear seat for two passengers. Fold the seat flat for a cargo platform (5).

Rear Seats Armrest

There are rear seats armrest (6), one on each side of the rear seat to help passengers stay in position when the vehicle is in motion. The passengers must hold the rear armrest (6) whenever the vehicle is in motion (Figure 6).

INTRODUCTION

Read all of SAFETY and this section before attempting any procedure. Pay particular attention to Notices, Cautions, Warnings and Dangers

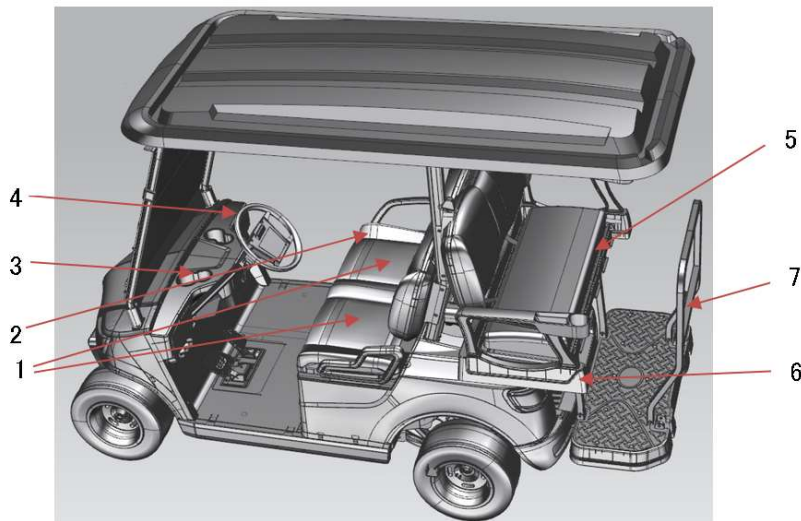

Figure 6

Charger Receptacle

Connect the charger cord to this charger receptacle (11) to charge the batteries (Figure 6).

Weather Enclosure (if equipped)

A weather enclosure provides protection from strong weather conditions.

Rear View Mirror (if equipped)

The rear view mirror is adjustable for use during the day or night.

DC to DC Converter

The DC to DC Converter Supplies power to the power accessories.

Battery Compartment

Lift the front seat to access the battery compartment for maintenance of the batteries and for access to the Tow Switch.

In the DS-A2-2 L6e model,

1. There is a **plastic isolator plate with a key lock**. According to the European Regulation, the street legal model should protect the battery compartment with one locked door, so this locked plated will be only allowed the Owner authorized person to service.
2. There is a **seat sensor under the driver seat**, only when the driver sit on the cart, then it can drive the cart. When driver leave the seat, it will release an alarm signal sound, this is the L6E EEC requirement.
3. There is an **Emergency Stop Button** located on the Seat pop, According to European EEC Regulation requirement, this button is a Must for driver emergency stop the whole cart power supply;
4. There is a **Lock** on the steering column, the function for locking the steering wheel



Charger Receptacle



Battery Compartment Isolator plate



Emergency Stop Button



Lock For Steering Wheel

Read all of **SAFETY** and this section before attempting any procedure. Pay particular attention to **Notices, Cautions, Warnings and Dangers**.

INSTRUCTIONS ABOUT Massimo UTILITY CARTS DU-CA500

1、 REAR CARGO TIPPING FEATURE OPERATION

When turning the key switch to , the cargo bed is in the original position, long press the up switch, the cargo bed will rise up. When tilted to the maximum angle, an alarm will sound, please release the up switch to prevent the motor from burning out. Long pressing the down switch, the cargo bed will down and release the down switch when returning to the original position.

2、 The door of cargo bed operation

- ①Open the handle(1) as shown(Figure 1).
- ②Open the clasp(2) and reset the handle(1) as shown(Figure 2).
- ③Repeat the step①and② on the other side.
- ④Open the door of cargo hopper (1) as shown(Figure 3).
- ⑤Reverse the above operations to close the door of cargo bed



Figure 1



Figure 2



Figure 3

INTRODUCTION OPERATING PROCEDURES

Read all of SAFETY and this section before attempting any procedure. Pay particular attention to Notices, Cautions, Warnings and Dangers.

OPERATING PROCEDURES

VIN Number ,Chassis Number and Nameplate Location

1. **Nameplate** is contain the manufacture information , the basic golf cart configuration and the production date. The VIN Number is on this nameplate as well, it is start from L4M*****; Any warranty complaint or spare parts request, please supply this VIN Number to Massimo with the model name.

Nameplate r

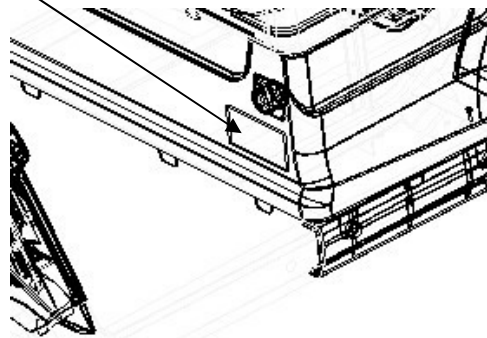

Nameplate Location is mounting on the seat pot under the socket

2. The VIN number and chassis number is mounted on the front end of Chassis. Chassis number Start from GD****,

VIN and Chassis Number Location, DS-A2-2 model Must Engrave on the right frame

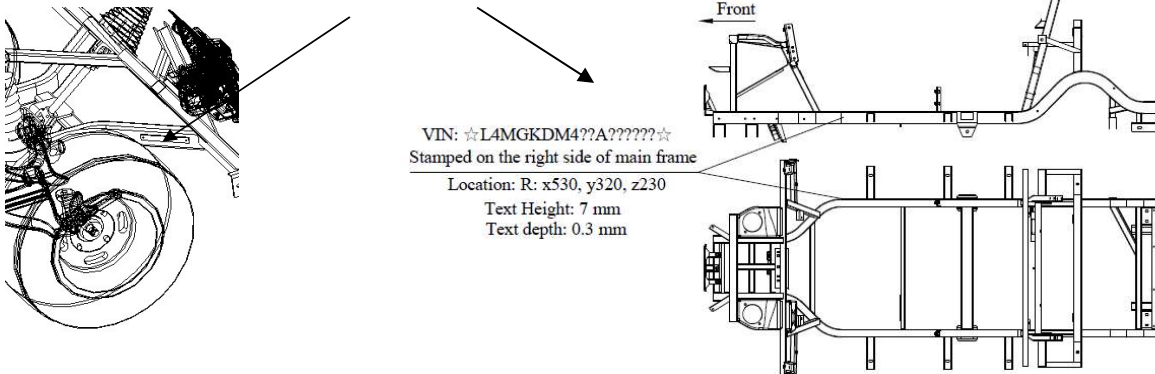

CAUTION

Improper use of the vehicle or the lack of proper maintenance may result in damage or decreased performance.

OPERATING PROCEDURES

Read all of SAFETY and this section before attempting any procedure. Pay particular attention to Notices, Cautions, Warnings and Dangers.

BEFORE INITIAL USE

Read, understand and follow the safety label on the cup holder. Make sure you understand how to safely operate the vehicle and its equipment.

WARNING

Reckless use of this vehicle can cause severe injury or death. This vehicle is a light-duty vehicle, NOT an All Terrain Vehicle (ATV).

Do not engage in rough or reckless operation of this vehicle.

If you do not know the terrain, make sure you prepare for unexpected occurrences. If the vehicle gets stuck or the batteries discharge, a one-hour drive can take many hours to return on foot.

Explosive hydrogen gas is created during the charge cycle of batteries. Do not charge batteries without enough ventilation. A 4% concentration of hydrogen gas is explosive.

To prevent battery explosion, keep all flammable materials, open flame or sparks away from the batteries.

Explosive hydrogen gas is created during the charge cycle of the batteries. Good ventilation is necessary to remove gas from enclosed spaces. The air must change every 12 minutes.

Never charge a battery near flammable materials, open flame or sparks. Never charge a vehicle near gas water heaters and furnaces.

Before a new vehicle is put into operation, complete the items shown in the **INITIAL SERVICE CHART**.

INITIAL SERVICE CHART	
Item	Service Operation
On Board Charger	Remove from vehicle and correctly install.
Batteries	Charge batteries.
Seats	Remove protective plastic covering.
Brakes	Check operation.
	Calculate the distance necessary to stop the vehicle for the brake performance test.
Tires (18*8, 50-8)	Check air pressure (18-22 psi)
Tire (20/10-10)	Check air pressure (30 psi)
Tire (215/35-12)	Check air pressure (60 psi)
Tire (22*11-12)	Check air pressure (20 psi)
General	Check for possible leaks that may have started during shipment

ON BOARD CHARGER INSTALLATION

DANGER

Risk of electric shock. Connect the charger power cord to an outlet that is correctly installed and connected to an electrical ground according to all codes and regulations. A grounded outlet is necessary to decrease the risk of electric shock – do not use ground adapters or replace the plug. Do not touch parts of output connector or battery terminals that do not have insulation.

OPERATING PROCEDURES

Read all of SAFETY and this section before attempting any procedure. Pay particular attention to Notices, Cautions, Warnings and Dangers.

DANGER

Disconnect the DC plug before you make or break the connections to a battery that is charging. Do not open or disassemble the charger. Do not operate the charger if the AC cord is damaged. Make sure qualified personnel does all repair work to the charger.

WARNING

Do not allow children to use the charger.

To prevent over-heating that can cause damage to the charger and possible fire, keep the air fins clear. Install portable chargers on a platform above the ground to allow maximum air flow around and below the charger.

Use the charger on 48-volt battery systems. Other use can cause personal injury and damage.

Lead acid batteries can create explosive hydrogen gas during normal operation. Keep sparks, flames and flammable materials away from batteries.

Supply enough ventilation during the charge cycle.

Never charge a frozen battery.

Read all of the manufacturers specified precautions for the battery. For example, recommended rates of charge and removal of cell caps during charge cycle.

Portable chargers are supplied with the vehicles. Before vehicle or charger operation, remove the charger from the vehicle. **A dedicated circuit is necessary for the charger.** Refer to the charger manual for correct circuit protection. For best performance and shortest charge times, put the charger in an area with good ventilation.

The list below supplies points to keep the charger cool while in operation.

- Put the charger in an area that is without dirt, mud or dust to prevent build-up in the charger fins.
- Put the charger on a horizontal surface with the fins vertical.
- Put the charger on a platform above the ground to allow air to flow around and below the charger.

If the charger is operated in an outdoor location, rain and sun protection must be supplied.

Because the charger can get hot during operation, install in an area with minimum person traffic to decrease possible contact with hot charger.

Make sure the status display on the charger is visible to the user.

NOTICE

Put the DC cord through the center of the steering wheel to remind you to put the cord away when finished with the charger. You can damage the DC plug if you drive over or catch the cord on the vehicle when you drive away.

WARNING

To decrease the possibility of electrical shock or electrocution, make sure that the charger plug is not damaged and is correctly connected to a grounded outlet.

The power AC cord has a plug with a ground post. Do not remove, cut or bend the ground post.

OPERATING PROCEDURES

Read all of SAFETY and this section before attempting any procedure. Pay particular attention to Notices, Cautions, Warnings and Dangers.

WARNING

The charger DC cord has a polarized connector which fits into a receptacle on the vehicle.

NOTICE

If the vehicle is charged with a charger different from the one supplied with the vehicle, refer to the instructions supplied with the charger used.

Provide Protection from Elements



Keep cooling fins clean and free of dirt and debris
NEMA 15 - 5R Grounded AC Receptacle
85 - 265VAC. Reference appropriate local electrical code and charger manufacturer recommendations for AC power requirements

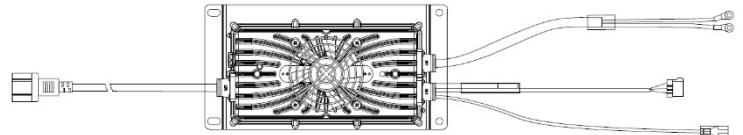

WARNING

To decrease the possibility of electrical shock or electrocution, make sure that the charger plug is not damaged and is correctly connected to a grounded outlet.

The power AC cord has a plug with a ground post. Do not remove, cut or bend the ground post.

The charger DC cord has a polarized connector which fits into a receptacle on the vehicle. The receptacle is located on the driver side of the vehicle below the seat.

HOW TO USE THE CHARGER

The charger can stay connected to the AC outlet after the charge cycle is complete.

To charge the vehicle, refer to the instruction labels on the charger.

Completely connect the DC plug into the vehicle receptacle. The charger will automatically start seconds after the plug is in position. The charger will automatically stop when the batteries are charged. Remove the DC plug before you operate the vehicle.

CHARGER MAINTENANCE

1. Make sure the charger connections to the battery terminals are tight and clean. Check for damage or cracks in the plastic parts.
2. Inspect the charger harness for wear and check the areas that contact other components. Inspect all wires for wear, loose terminals, corrosion or damage to the insulation.
3. Clean dirt and any other particles from the cooling fins. Keep the charger away from oil, dirt and mud. Do not allow water to spray on the charger when you clean equipment.
4. Inspect the plug of the battery charger and the vehicle receptacle housing for dirt or dust. Clean a minimum of once a month.

Charging indicator

Charging Socket

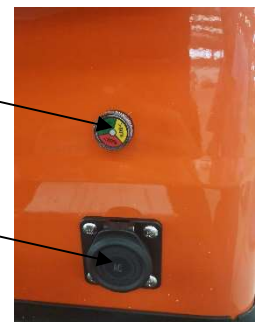

OPERATING PROCEDURES

Read all of SAFETY and this section before attempting any procedure. Pay particular attention to Notices, Cautions, Warnings and Dangers.

HOW TO OPERATE THE VEHICLE?

CAUTION

Incorrect use of the vehicle or lack of maintenance can cause damage or decreased performance.

Read the following warnings before you operate the vehicle.

WARNING

To decrease the risk of severe injury or death resulting from loss of vehicle control, the following warnings must be obeyed:

When driving vehicle, understand the terrain, traffic conditions and the environmental conditions which change the terrain and the ability to control the vehicle. When possible, stay in approved areas and do not drive on steep slopes.

Speed in reverse must be limited to a maximum of 10 MPH.

Keep a safe speed when driving down hill. Use the brake to control speed when traveling down a slope. A sudden stop or change of direction can cause loss of control.

Decrease speed before and during turns. Never drive the vehicle up, down, or across a slope that is more than the prescribed driving gradient of the vehicle

See GENERAL SPECIFICATIONS for the vehicle load and seat capacity.

To decrease the risk of severe injury or death resulting from improper vehicle operation, the following warnings must be obeyed:

Pressing accelerator pedal can cause accidental vehicle movement. Turn the key to the OFF position when the vehicle is parked. When you leave the vehicle, turn the key to the OFF position and remove from the switch to prevent accidental operation.

To prevent accidental movement when the vehicle is to be left without an operator, turn the key to the OFF position and remove the key.

Always stop the vehicle before moving the direction selector.

Do not take the vehicle out of gear while in motion (move without power).

Check the area behind the vehicle before you operate in the reverse direction.

All persons must be seated. Keep entire body inside vehicle and hold on while vehicle is in motion.

Incorrect and irresponsible operation of this vehicle can cause dangerous conditions for the operator, passengers and other people in the area. Do not allow children or anyone without a license to operate the vehicle. Children may not have the skill and ability to make good decisions or strength to operate the vehicle.

Drugs and alcohol decrease the ability of the driver to operate the vehicle safely. Always check with a medical professional before you operate the vehicle.

When you drive the vehicle at full speed on a dirt road, loose surface or wet grass, the necessary distance to stop the vehicle will increase. The necessary distance to stop a loaded vehicle is more than the necessary distance to stop a vehicle without a load. In wet weather conditions, apply light pressure to the brakes to supply enough friction to dry the brake unit. Wet brakes lose much of their effect.

If you drive on a steep hill and cannot get enough traction, do not try to turn around on the hill. Slowly drive in reverse and use the brake to control the speed.

Read all of SAFETY and this section before attempting any procedure. Pay particular attention to Notices, Cautions, Warnings and Dangers.

Direction Selector Operation

WARNING

To prevent loss of control, do not move the direction selector to a different position while the vehicle is in motion. If you move the selector, the speed will immediately decrease and a warning device activates.

Move the direction selector to FWD (forward) to move in the forward direction.

Move the direction selector to REV (reverse) to move in the reverse direction. A reverse warning buzzer activates when the direction selector is moved to the REV (reverse) position.

The position between FWD (forward) and REV (reverse) is the neutral position.

When you leave the vehicle, turn the key to the OFF position and remove it from the key switch.

Accelerator and Brake Pedal Operation

With the key switch in the FWD (forward) or REV (reverse) position, press the accelerator pedal (1), which starts the motor and the vehicle moves in the direction indicated on the key switch/direction selector. This vehicle is equipped with motor brake. When the accelerator pedal is released, the motor will stop. To stop the vehicle quickly, press the brake pedal (2) (Figure 2).

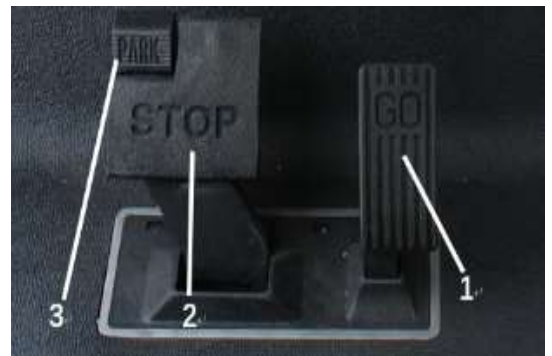

Figure 2 Accelerator and Brake Pedal Operation

Horn (if equipped)

If the vehicle is equipped with a horn, the horn button (3) is located on the driver's side of the floorboard. Pressing the button (3) will sound the vehicle's horn (Figure 2).

Tow switch operation (If equipped)

NOTICE

Before starting the vehicle, please check whether the toggle switch is in the NO state.

The car will not be able to move. Please turn off the toggle switch when you will not start the vehicle for a long time .

Curtis Programmer Port



Figure 3 Curtis Programmer Port

OPERATING PROCEDURES

Read all of SAFETY and this section before attempting any procedure. Pay particular attention to Notices, Cautions, Warnings and Dangers.

Rear Seat and Cargo Platform Operation (if equipped)



CAUTION

To prevent damage to the rear seat, move any accessories that are installed on the hand rail, when you fold the seat.

Fold the seat to the flat position to access the cargo platform.



WARNING

Secure the loads on the platform to prevent movement.

Put the load on the platform as far forward as possible.

The center of gravity of the load must be less than 4 inches (10 cm) above the platform.

Do not put more than the specified capacity on the platform.

Increased loads can change drive properties of the vehicle.

Do not allow passengers to ride on the cargo platform.

When you put cargo on the platform, make sure you follow the information below to decrease the risk of injury, damage to the vehicle or cause the vehicle to tilt.

- Put the load on the platform as far forward as possible.
- Secure the loads on the platform to prevent movement.
- The center of gravity of the load must be less than 4 inches (10 cm) above the platform.
- The load capacity of the cargo platform is a maximum of 250 lbs. (115 kg). Do not put more than the specified capacity on the platform.

Increased loads can change the drive properties of the vehicle.

Regenerative Braking



WARNING

To prevent the possibility of loss of control that could cause severe injury or death, use brake to reduce speed.

This vehicle is equipped with a regenerative motor control system.

Example: If both of the following events occur:

- a. The vehicle is being driven down a slope.
- b. The driver attempts to exceed the specified top speed with the accelerator pedal pressed **or** released

The regenerative braking will limit the speed of the vehicle to the specified top speed. When the regenerative braking system is activated by this sequence of events, the motor generates power that is returned to the batteries. When the vehicle speed is reduced below the maximum by using the brake, the speed will not increase unless the throttle is increased. When the brake pedal is released the vehicle will slow down as it does with pedal up braking.

OPERATING PROCEDURES

Read all of SAFETY and this section before attempting any procedure. Pay particular attention to Notices, Cautions, Warnings and Dangers.

Pedal-Up Braking

Pedal-up braking is regenerative braking that occurs when the accelerator pedal is released while the vehicle is moving.

Example: If both of the following events occur:

- a. The vehicle is being driven down a slope
- b. The accelerator pedal is released

The pedal-up braking will slow the vehicle until the vehicle stops, or the accelerator is applied. When pedal-up braking system is activated by this sequence of events, the motor generates power that is returned to the batteries.

High Pedal Disable Feature

High pedal disable prevents acceleration if the key is turned on while the accelerator or brake are pressed. To reset the controller after a High Pedal Disable, place both feet on the floor, turn the key to the OFF position. With both feet on the floor turn the key to the desired direction and press the accelerator.

STARTING AND DRIVING

All vehicles have an interlock system that disables the controller and prevents operation or tow of the vehicle while the charger is connected. Remove the charger plug from the receptacle and correctly store the cable before you move the vehicle.

To operate the vehicle:

- Put the key in the key switch and turn to the desired position.
- Slowly press the accelerator pedal to start the motor.
- When the accelerator pedal is released, the motor decreases the speed of the vehicle. To stop the vehicle quickly, press the brake pedal.

NOTICE

When the direction selector is in the reverse position, a warning signal will sound to indicate that the vehicle is ready to run in reverse.

Starting Vehicle On A Hill

The parking brake will activate automatically when the vehicle stops. To start the vehicle on a hill press the accelerator pedal and the parking brake will be released.

Coasting

Uncontrolled coasting does not occur with this model. However, this is not a substitute for the brake which must be used to quickly decrease the speed of the vehicle.

LABELS AND PICTOGRAMS

Vehicles may be labeled with pictograms as a method of conveying information or warnings. The Vehicle Label Identification Section of this manual explains the labels that are used on this vehicle.

OPERATING PROCEDURES

Read all of SAFETY and this section before attempting any procedure. Pay particular attention to Notices, Cautions, Warnings and Dangers.

SUN TOP AND WINDSHIELD (IF EQUIPPED)

WARNING

The sun top does not provide protection from roll-over or falling objects.

The windshield does not provide protection from tree limbs or flying objects.

The sun top and windshield provide some protection from the elements; however, they will not keep the operator and passenger dry in heavy rain. This vehicle is not equipped with seat belts and the sun top has not been designed to provide roll-over protection. In addition, the sun top does not protect against falling objects nor does the windshield protect against flying objects and tree limbs. Keep arms and legs inside whenever the vehicle is in motion.

Read all of SAFETY and this section before attempting any procedure. Pay particular attention to Notices, Cautions, Warnings and Dangers.

MAINTENANCE

VEHICLE CLEANING AND CARE

WARNING

To decrease the risk of severe injury read and understand all instructions supplied by the manufacturer of the pressure washer before use.

CAUTION

When you clean the outside of the vehicle with a pressure washer, do not use more than 700-psi pressure. Keep a minimum distance of 12 inches from the spray nozzle to the painted surface. Do not clean the plastic parts with abrasive solvents.

Make sure you use correct methods and cleaning materials to prevent risk of damage to the outside of the vehicle. The use of more than 700-psi water pressure can cause injury to anyone in the area or damage to vehicle.

Clean the windshield with water and a clean cloth. Remove small scratches with a plastic polish or Plexus[®] plastic cleaner, available from the service parts department.

Apply a soap and water solution with a sponge or soft brush to clean the vinyl seats and plastic or rubber trim. Dry with a cloth.

Use a commercially available vinyl and rubber cleaner to remove oil, tar, asphalt, shoe polish, etc.

Wash the vehicle frequently with cool water and mild detergent to protect the painted surfaces.

Apply wax that is for clear coat automotive finishes to improve the appearance and protection of the painted surfaces. Do not apply wax to matte finish surfaces.

Occasional cleaning and waxing with non-abrasive products designed for clear coat automotive finishes will enhance the appearance and durability of the painted surfaces.

Materials used as fertilizers or for dust control can collect on the bottom of the vehicle. These materials will cause Corrosion of components, unless cleaned with water. Clean areas where mud or dirt can collect. Loosen the sediment that is packed in closed areas to help with removal. Be careful not to damage the paint.

ENVIRONMENTAL CONCERNS

WARNING

As a responsible user, practice respect for all wildlife and their habitat. Respect private property and comply with all local laws and regulations governing the use of light duty utility vehicles.

Always be respectful of the environment.

Make sure you are permitted by property owners to operate the vehicle on their property.

There is a risk of fire when the vehicle is operated near combustibile material.

Be careful of environmental hazards like steep slopes, tree branches, etc.

MAINTENANCE

Read all of SAFETY and this section before attempting any procedure. Pay particular attention to Notices, Cautions, Warnings and Dangers.

Battery Disposal

Return used batteries to the manufacturer or lead smelter for recycling purposes. For neutralized spills, put residue in acid-resistant containers with absorbent material, sand or earth and discard according to state and federal regulations for acid and lead compounds. Contact authorized environmental people for information about disposal.

LIFTING THE VEHICLE

You must lift the front, the rear or the entire vehicle for some service and maintenance operations.

WARNING

The vehicle is not stable during the lifting process.

Make sure the vehicle is on a hard and level surface.

Never get below a vehicle that is supported by a jack only.

Make sure a vehicle that is supported on jack stands is stable before you get below the vehicle.

Put wheel chocks in front and behind the wheels that remain on the ground.

Do not allow any person in or on the vehicle being lifted.

CAUTION

When you lift the vehicle, put the jacks and jack stands at the areas indicated only.

Tool List	Quantity	Tool List	Quantity
Floor Jack.....	1	Jack Stands.....	4
Wheel Chocks	4		

Remove payload from vehicle before lifting. No person(s) should be in or on the vehicle while lifting.

How to lift the entire vehicle:

1. Install wheel chocks in front and behind each front wheel. 2. Center the jack under the bagwell.
3. Lift the vehicle enough to place two jack stands under the frame where the leaf spring mounting brackets are welded to the frame. 4. Lower the jack and test the stability of the vehicle on the two jack stands. 5. Place the jack under the center front just behind the bumper.
6. Lift the vehicle and place two jack stands under the frame where the instrument panel support is attached to the frame.
7. Lower the jack and test the stability of the vehicle on the jack stands.

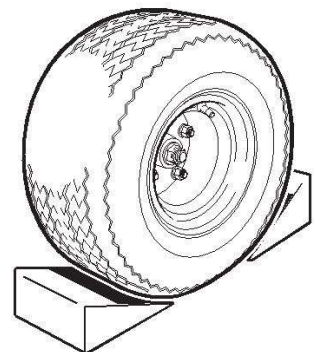

How to lift the rear of the vehicle only

1. Install wheel chocks in front and behind each rear wheel.
2. Center the jack under the bagwell.
3. Lift the vehicle enough to place two jack stands under the frame where the leaf spring mounting brackets are welded to the frame.
4. Lower the jack and test the stability of the vehicle on the jack stands.

Read all of SAFETY and this section before attempting any procedure. Pay particular attention to Notices, Cautions, Warnings and Dangers.

How to lift the front of the vehicle only :

1. Install wheel chocks in front and behind each front wheel.
2. Place the jack under the center front just behind the bumper.
3. Lift the vehicle and place two jack stands under the frame where the instrument panel support is attached to the frame.
4. Lower the jack and test the stability of the vehicle on the jack stands.

Lower the vehicle:

1. Lift the vehicle enough to remove the jack stands.
2. Carefully lower the vehicle to the ground with the jack.

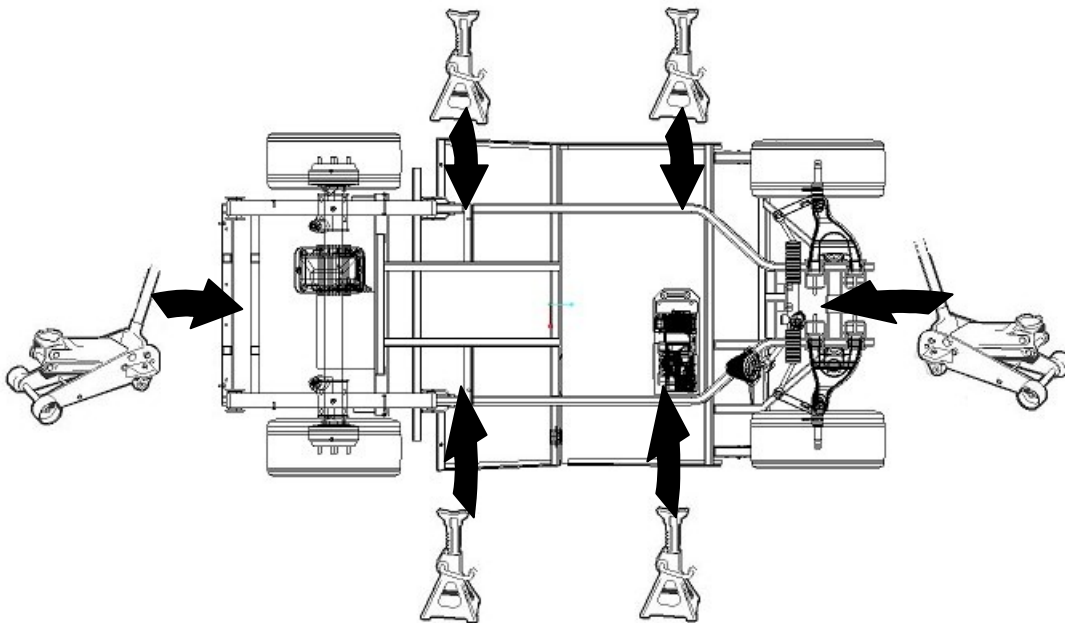

WHEELS AND TIRES

Recommended tire inflation pressure: 18-22 psi

⚠ WARNING

To decrease the risk of tire explosion, add small amounts of air to the tire at intervals to seat the tire beads. Over inflation of small tires can occur in a few seconds.

Do not over inflate the tires. Excess pressure can cause the tire to separate from the wheel or explode.

Protect face and eyes when removing a tire valve core.

Use only sockets made for use with impact wrenches to decrease the risk of injury caused by a broken socket.

Do not use tires that have a recommended tire inflation pressure less than the tire pressure recommended.

Tire Repair

Tool List	Quantity	Tool List	Quantity
Lug Wrench, 3/4"		Impact Socket, 3/4"	1
Impact Wrench	1	Torque Wrench, ft. lbs.	1

Use caution when you inflate the tires. Because of the low volume of the small tires, over inflation can occur in seconds. Over inflation can cause the tire to separate from the wheel or cause a tire explosion.

The general recommended tire inflation pressure is 18-22 psi, but know that tire inflation pressure can change according to the condition of the terrain.

For outdoor applications with primary use on areas with grass, consider the following:

- Slightly higher tire inflation pressure is suitable on hard turf
- A lower pressure decreases the risk of tires cutting into a soft turf

For hard surfaces or pavement, tire inflation pressure must be in the higher allowed range, but not more than recommended on the tire sidewall.

All four tires must have the same pressure for best control qualities. Always install the valve stem cap after you check or inflate the tires.

The vehicle has low-pressure tubeless tires, installed on one-piece rims.

Use a tire plug to repair small holes in the tread part of the tire. For large holes and cuts, replace the tire.

NOTICE

Tire plug tools and plugs are available at automotive outlets. The tires do not have to be removed from the wheel to install the tire plugs.

If the tire is flat, remove the wheel and inflate the tire to the recommended maximum pressure for the tire. Submerge the tire in water to find the leak and mark with chalk. Install the tire plug according to manufacturer's instructions.

Wheel Installation

CAUTION

To decrease the risk of component damage, do not tighten lug nuts to more than 85 ft. lbs. (115 Nm) torque.

NOTICE

Always follow the cross-sequence pattern when you install the lug nuts to make sure the wheel is evenly seated against the hub.

- With the valve stem to the outside of the wheel, install the wheel on the hub with lug nuts.
- Tighten the lug nuts (1) with your fingers in the cross-sequence pattern shown.
- Tighten the lug nuts to 50 to 85 ft. lbs. (70 to 115 Nm) torque in 20 ft. lbs. (27 Nm) increments.
- Continue to follow the cross-sequence pattern until the correct torque is reached.

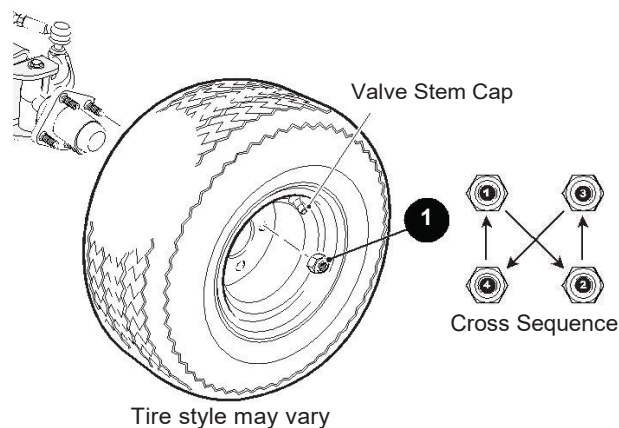

Read all of **SAFETY** and this section before attempting any procedure. Pay particular attention to **Notices, Cautions, Warnings and Dangers.**

LIGHT BULB REPLACEMENT

CAUTION

To decrease the risk of premature bulb failure, do not allow your fingers to contact new bulbs. Use clean, dry paper or paper towels to touch the glass part of the bulb.

Headlight (if equipped)

Make sure that the vehicle key switch is in the OFF position and the key has been removed. For vehicles equipped with lights mounted in the cowl locate the headlight bulb socket on the backside of the light assembly.

Replace the entire headlight

- Disconnect the wiring harness (1) (Figure 1)
- Use a Phillips screwdriver to take out the bolts (2)(3)(4) (5) and take out the headlight assembly
- Replace with new headlights and fix the bolts at (2)(3)(4) (5)
- Connect the upper wiring harness (1)

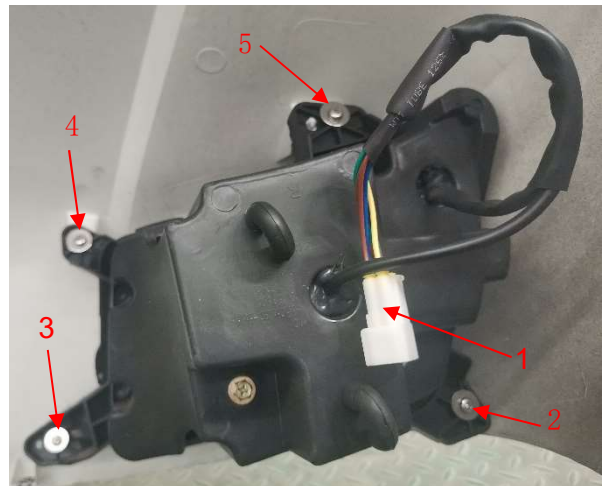

Figure 1 Headlight

Taillight/brake (if equipped)

Make sure that the vehicle key switch is in the OFF position and the key has been removed.

- Remove the nail (1)(2)(3)(4)(5)(6) with a Phillips screwdriver, and take out the maintenance cover (7).
 - Remove the screw (12) with a Phillips screwdriver, and take out the rear tail light (13).
 - Separate the wiring harness (8) to take out the rear light.
- Replace with a new rear light and connect the wiring harness (8).
- Fix the bolt (1)(2)(3)(4)(5)(6) with a Phillips screwdriver.
 - Cover the repair cover (7).



Figure 2 Taillight/brake

MAINTENANCE

Read all of SAFETY and this section before attempting any procedure. Pay particular attention to Notices, Cautions, Warnings and Dangers.

TRANSPORTING VEHICLE

Towing

WARNING

Use extra caution when towing a vehicle.

DO NOT ride on the vehicle being towed.

DO NOT try to tow the vehicle with ropes, chains or any device other than tow bar approved by the factory.

DO NOT tow the vehicle on highways.

DO NOT tow a single vehicle at speeds in excess of 12 mph (19 kph).

DO NOT exceed 5 mph (8 kph) while towing multiple vehicles.

DO NOT tow more than three vehicles at a time.

Before the vehicle, put the run/tow switch in the TOW position.

CAUTION

Before Towing the vehicle, please release the brake to avoid towing make the brake system, Motor and the controller broken.

Do not tow a single vehicle at speeds in excess of 12 mph (19 kph). Do not tow more than three vehicles at a time. Do not exceed 5 mph (8 kph) while towing multiple vehicles. Towing the vehicle above the recommended speed may result in severe injury and/or damage to the vehicle and other property.

Tow bars are not intended for road use.

Never use ropes or chains to tow vehicle(s). Tow bars are available from the Massimo Service Parts Department.

Tow bars are not intended for highway use. Do not ride on a vehicle being towed. Tow bars are designed to tow only one vehicle at a maximum speed of 12 mph (19 kph) and up to three vehicles at a maximum speed of 5 mph (8 kph).

Hauling

WARNING

Make sure you secure the vehicle and all items before you transport a vehicle on a trailer.

Do not allow any people on a vehicle being transported on a trailer.

When you transport the vehicle on a trailer below highway speeds, check for tight hardware and cracks in sun top at the mounting points.

The rated capacity of the trailer or truck must be more than the weight of the vehicle and load plus 1000 lbs. (454 kg).

See GENERAL SPECIFICATIONS for the weight of the vehicle.

Secure the vehicle to the trailer with ratchet tie downs.

Read all of SAFETY and this section before attempting any procedure. Pay particular attention to Notices, Cautions, Warnings and Dangers.

SERVICE AND MAINTENANCE

WARNING

Read all notices, cautions and warnings in this manual before you do any type of service operations.

The drive wheels must be lifted and supported on jack stands before you do any service to the powertrain when the motor is in operation.

To decrease the risk of motor damage, do not operate the vehicle at full throttle for more than 5 seconds with the drive wheels lifted off the ground.

Disconnect the negative battery cable before you service the vehicle to prevent accidental operation.



Wear eye protection when you service the vehicle. Be careful when you do work around batteries, use solvents or compressed air.

To decrease the risk of electrical arc, which can cause a battery explosion, disable all electrical loads from the battery before you remove the battery wires.

Use wrenches with insulation to decrease the risk of a short-circuit if a wrench falls across the battery terminals. A battery short-circuit can cause an explosion.

The electrolyte in a battery is an acid solution which can cause burns to the skin and eyes. Completely clean all electrolyte spills that contact the body and eyes with clear water. Contact a physician immediately.

Neutralize electrolyte spills with a solution of 2 teaspoons (10 ml) sodium bicarbonate (baking soda) mixed in 1 quart (1 liter) of water. Clean with water.

Be careful when you use the aerosol containers near battery terminals. Use a metal container that has insulation to prevent an explosion.

MAINTENANCE

Read all of SAFETY and this section before attempting any procedure. Pay particular attention to Notices, Cautions, Warnings and Dangers.

The vehicle owner and service technician must carefully follow the procedures recommended in this manual. The preventative maintenance, applied at recommended intervals, keeps the vehicle dependable and decreases costs for repairs. Refer to the Periodic Service Schedule for service and intervals. Refer to Lubrication Points for correct lubrication locations.

CAUTION

To decrease the risk of damage to the controller or motor, make sure the run/tow switch to is set to the TOW position before you tow the vehicle.

Before you disconnect or connect a battery or any other wires, make sure the run/tow switch to is set to the RUN position.

After you connect a battery or any other wires, wait a minimum of 30 seconds before you move the key switch to the ON position.

ROUTINE MAINTENANCE

CAUTION

To increase the life of a vehicle that is used in rough conditions, some maintenance must be done more often than recommended in the Periodic Service Schedule. For example: high or low temperatures, high dust and dirt conditions, high use with maximum load.

To access the powertrain for normal maintenance, lift or remove the seat and remove the rear access panel. For major repairs, refer to the applicable Technician's Repair and Service Manual.

Some service procedures make it necessary to lift the vehicle. Refer to LIFTING THE VEHICLE for correct lift procedure and safety information.

TIRE INSPECTION

Inspect the tire condition according to the Periodic Service Schedule. Tire inflation pressures must be checked when the tires are cool. Always install the valve dust cap after you check or inflate the tires.

BRAKES

WARNING

Always inspect the pedal travel before you operate a vehicle to confirm some brake function is found.

Make sure you do all brake tests in a safe location with regard to the safety of all personnel.

NOTICE

A subtle loss of performance can occur over time; therefore, it is important to establish the standard with a new vehicle.

The Periodic Brake Performance Test should be performed regularly as an evaluation of braking system performance. It is useful as a method of identifying subtle loss of performance over time.

Read all of SAFETY and this section before attempting any procedure. Pay particular attention to Notices, Cautions, Warnings and Dangers.

REAR AXLE

The only maintenance necessary for the first five years is the inspection of the rear axle for lubricant leakage. Unless leakage is visible, the lubricant needs to be replaced after five years. Refer to the Service and Repair Manual for the fluid replacement procedure.

Checking the Lubricant Level

Clean the area around the check/fill plug and remove the plug. The correct lubricant level is just below the bottom of the threaded hole. If lubricant is low, add lubricant as required. Add lubricant (0 WT engine oil) slowly until lubricant starts to seep from the hole. Install the check/fill plug. In the event that the lubricant is to be replaced, the oil pan must be removed or the oil siphoned through the check/fill hole.

HARDWARE

Normally, three classes of standard hardware and three classes of metric hardware are used in the vehicle. Grade 5 hardware is identified by the three marks on the hexagonal head; grade 8 hardware is identified by six marks on the head; grade 2 hardware is not marked. The class specification is marked on metric hardware.

Inspect the vehicle for loose fasteners periodically. The fasteners must be tightened carefully and according to the Torque Specifications table or as specified in the Repair and Service Manual.







ALL TORQUE FIGURES ARE IN FT. LBS. (Nm)											
Unless otherwise noted in text, tighten all hardware in accordance with this chart. This chart specifies 'lubricated' torque figures. Fasteners that are plated or lubricated when installed are considered 'wet' and require approximately 80% of the torque required for 'dry' fasteners.											
BOLT SIZE		1/4"	5/16"	3/8"	7/16"	1/2"	9/16"	5/8"	3/4"	7/8"	1"
Grade 2		4 (5)	8 (11)	15 (20)	24 (33)	35 (47)	55 (75)	75 (102)	130 (176)	125 (169)	190 (258)
Grade 5		6 (8)	13 (18)	23 (31)	35 (47)	55 (75)	80 (108)	110 (149)	200 (271)	320 (434)	480 (651)
Grade 8		6 (8)	18 (24)	35 (47)	55 (75)	80 (108)	110 (149)	170 (230)	280 (380)	460 (624)	680 (922)
BOLT SIZE		M4	M5	M6	M8	M10	M12	M14			
Class 5.8 (Grade 2)		1 (2)	2 (3)	4 (6)	10 (14)	20 (27)	35 (47)	55 (76.4)			
Class 8.8 (Grade 5)		2 (3)	4 (6)	7 (10)	18 (24)	35 (47)	61 (83)	97 (131)			
Class 10.9 (Grade 8)		3 (4)	6 (8)	10 (14)	25 (34)	49 (66)	86 (117)	136 (184)			

Figure 4 Torque Specifications and Bolt Grades

MAINTENANCE

Read all of SAFETY and this section before attempting any procedure. Pay particular attention to Notices, Cautions, Warnings and Dangers.

BATTERY CHARGING AND MAINTENANCE

Safety

Always obey the following warnings when working on or near batteries.

WARNING

To prevent the risk of battery explosion, keep all flammable materials, open flames or sparks away from the batteries.

Hydrogen gas is made as batteries are charged. Do not charge batteries without good ventilation. A 4% concentration of hydrogen gas is explosive.

Make sure that the key switch is in the OFF position and all electrical accessories are off before you start to work on the vehicle.

Turn off all accessories before disconnecting from the battery terminal.



Use safe procedures to move the batteries. Always lift the battery with a commercially available battery lifting device.

Do not tilt the batteries during removal or installation. An electrolyte spill can cause burns and damage.

The electrolyte in a storage battery is an acid solution which can cause burns to the skin and eyes. Treat all electrolyte spills to the body and eyes with extended flushing with clear water. Contact a physician immediately.

Always wear a safety shield or approved safety goggles when you add water or charge the batteries.

Neutralize electrolyte spills with a solution of 2 teaspoons (10 ml) sodium bicarbonate (baking soda) mixed in 1 quart (1 liter) of water. Clean with water.



If you fill the batteries with electrolyte above the maximum level, you can cause an electrolyte spill during the charge cycle. An electrolyte spill can cause damage to the vehicle and storage facility.

Be careful when you use aerosol containers near the battery terminals. Use a container with insulation to prevent an explosion.

Use wrenches with insulation to decrease the risk of a short-circuit if a wrench falls across the battery terminals. A battery short-circuit can cause an explosion.

Read all of SAFETY and this section before attempting any procedure. Pay particular attention to Notices, Cautions, Warnings and Dangers.

Battery

A battery is described as two dissimilar metals immersed in an acid. If the acid is absent or if the metals are not dissimilar, a battery has not been created. The batteries in this vehicle are lead acid.

A battery does not store electricity, but it can produce electricity as the result of a chemical reaction which releases stored chemical energy in the form of electrical energy. The chemical reaction occurs faster in warm conditions and slower in cold conditions. Temperature is important when conducting tests on a battery and test results must be corrected to adjust for temperature differences.

An older battery can perform adequately except that its capacity is decreased. Capacity describes the time that a battery can continue to supply its design amperes from a full charge.

A battery has a maximum life. Good maintenance maximizes the available life and decreases the conditions that can decrease the life of the battery.

Battery Maintenance

Tool List	Quantity	Tool List	Quantity
Insulated Wrench, 9/16"		Battery Carrier.....	1
Hydrometer.....	1	Battery Maintenance Kit P/N 25587G01	1
Battery Protective Spray.....	1	Socket, 9/16"	1
Torque Wrench	1		

At Each Charging Cycle

- Before you charge the batteries, inspect the plug of the battery charger and vehicle receptacle housing for dirt or other particles.
- Charge the batteries after each use.

Monthly

- Inspect all wires for wear, loose connections, corrosion or damage of insulation.
- Make sure that the electrolyte level is correct and add clean water as required.
- Clean the batteries and wire connections.
- Apply battery protectant to the battery terminals.

Electrolyte Level and Water

The correct level of the electrolyte is 1/2" (13 mm) above the plates in each cell.

This level will leave approximately 1/4" - 3/8" (6 - 10 mm) of space between the electrolyte and the vent tube.

The electrolyte level is important because any part of the plates open to air will be damaged.

Do not overfill with water. Too much water pushes the electrolyte from the battery by release of gas and a decrease in volume of the electrolyte.

MAINTENANCE

Read all of SAFETY and this section before attempting any procedure. Pay particular attention to Notices, Cautions, Warnings and Dangers.

⚠ CAUTION

DO NOT overfill batteries. The charge cycle will expel electrolyte and cause component damage.

A battery being charged will gas with most gassing occurring at the end of the charging cycle. This gas is hydrogen which is lighter than air. Water and sulphuric acid droplets will be carried out of the battery vents by the hydrogen gas, however, this loss is minimum. If the electrolyte level is high, the electrolyte will block the vent tube and the gas will push it out the vent tube and battery cap. The water will dry but the sulphuric acid will stay and damage the vehicle components and the storage facility floor. Sulphuric acid loss will weaken the amount of acid within the electrolyte and decrease the life of battery.

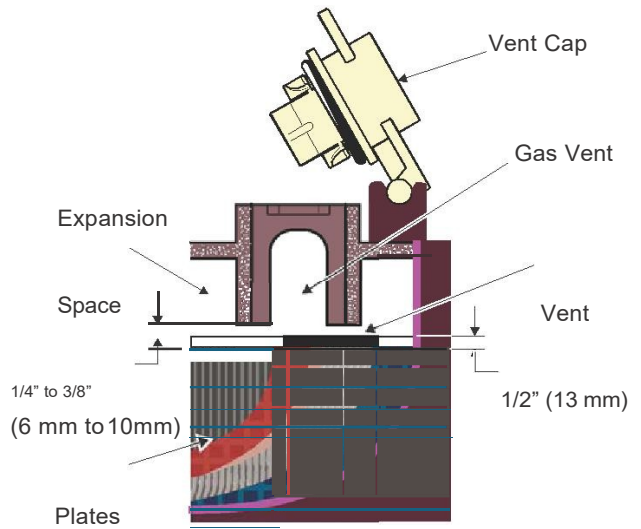

Electrolyte level should be at least 1/2" (13mm) above the plates and 1/4" to 3/8" (6 to 10 mm) below vent
Correct Electrolyte Level

Over the life of the battery, a large amount of water is used. The water used must be clean and without contamination. Water that is not clean decreases the life of the battery by reducing the chemical reaction. Use distilled water or filtered water only. Test water that is not distilled water and filter if needed. Refer to the water purity table for requirements.

Impurity	Parts Per Million
Color	Clear
Suspended	Trace
Total Solids	100
Calcium and Magnesium Oxides	40
Iron	5
Ammonia	8
Organic and Volatile Matter	50
Nitrites	5
Nitrates	10
Chloride	5

Water Purity Table

⚠ WARNING



The electrolyte in a battery is an acid solution which can cause severe burns to the skin and eyes. Clean all electrolyte spills to the body and eyes with clear water. Contact a physician immediately. To clean an electrolyte spill, use a solution of 2 teaspoons (10 ml) sodium bicarbonate (baking soda) mixed with 1 quart (1 liter) of water. Always wear a safety shield or approved safety goggles when you add water or charge the batteries.

Read all of SAFETY and this section before attempting any procedure. Pay particular attention to Notices, Cautions, Warnings and Dangers.

Battery Cleaning

CAUTION

To prevent battery damage, make sure you correctly install all battery caps.

To decrease the risk of damage to vehicle or floor, neutralize acid before you spray the battery with water.

To decrease the risk of damage to the electrical components while cleaning, do not use a pressure washer.

Clean the batteries according to the Periodic Service Schedule.

When you clean the battery cases and terminals, do not use a water hose without neutralizing any acid deposits first. The water hose moves the acid from the top of the batteries to another area of the vehicle or storage facility, where it can cause damage. After spraying the batteries, a conductive residue remains on the batteries and contribute to the discharge of the batteries

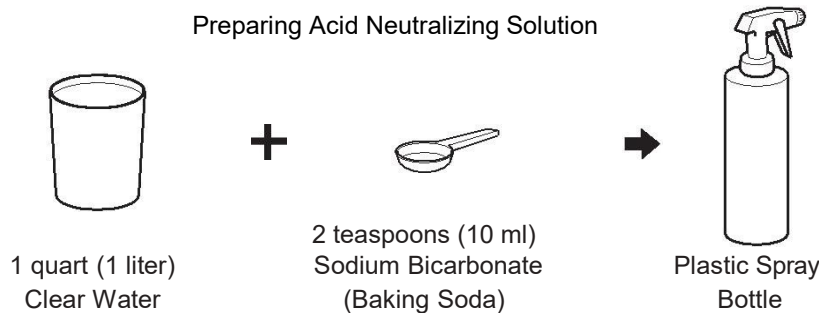

The correct cleaning method is to spray the top and sides of the batteries with a solution of baking soda and water. Apply this solution with a plastic spray bottle. The solution is 2 teaspoons (10 ml) sodium bicarbonate (baking soda) mixed with 1 quart (1 liter) of water. Spray the solution on all metal components near the batteries also.

Allow the solution to set a minimum of three minutes. Use a soft bristle brush or cloth to clean the top of each battery to remove residue that can cause the discharge of the battery. Clean the area with low pressure clear water.

WARNING

Be careful when you use aerosol containers near the battery terminals. Use a container with insulation to prevent an explosion.

Clean one time a month or more often in harsh conditions. After the batteries are clean and dry, apply a commercially available protectant to the terminals.

Battery Removal and Installation

Tool List

Insulated Wrench, 9/16"	
Socket, 9/16"	1
Battery Carrier Strap	1
Portable Lifting Device	1

Quantity

Tool List

Socket, 1/2" Deep-well	
Ratchet	1
Torque Wrench, in. lbs	1
Torx Bit, 50IP	1

Quantity

MAINTENANCE

Read all of **SAFETY** and this section before attempting any procedure. Pay particular attention to **Notices, Cautions, Warnings and Dangers.**

WARNING

The batteries are heavy. Use correct lifting methods when you move them. Always lift the battery with a commercially available battery lifting device. Be careful not to tilt batteries when you remove or installing them; spilled electrolyte can cause burns and damage.



NOTICE

Hardware that is removed must be installed in its original position unless otherwise specified. If torque values are not specified, refer to the Torque Specifications table.

1. Turn key switch to the OFF position and remove the key
2. Disconnect the main negative (-) battery cable (BL-)
3. Disconnect the main positive (+) battery cable (BL+)
4. Disconnect and remove all other wires connected to the batteries.
5. **6 - 8V Battery System:** Remove three hex nuts (2) securing battery retainer (1) until they are at the end of the Rod (3), unhook the J-bolts from the battery tray (4).
6. Remove the batteries using commercially available battery carrier straps (1 per battery) and a portable lifting device. Remove the four front batteries (5, 6, 7 and 8) one at a time; then Remove the two rear batteries (9 and 10) to the front of the vehicle just enough to clear the rear body and lift up and out of the vehicle, one after another.

7. Check the area around the battery tray for corrosion. If any corrosion is found, it must be immediately removed with a putty knife and a wire brush (for metal surfaces) or a plastic bristle brush (for plastic surfaces). The area must be washed with a solution of baking soda and water and dried completely. All metal surfaces that has been cleaned must be primed and painted with a corrosion resistant paint
8. Replace the batteries, starting with the battery (5) located at the rear end of the battery tray, by making sure that it is positioned as shown (8,9,10) (Figure 3)

9. Tie the rod with battery fixing cage, use Hex nutto fasten the rod and the force should control between 5 -6.2 N

10. Inspect all wires and terminals and clean any corrosion from the battery terminals or wire terminals with a solution of baking soda and water, using a wire brush to completely remove corrosion if required.
11. Carefully reconnect the wires on the battery terminals as shown (Figure 4). Make sure to reconnect the main negative (-) battery cable, BL-, from the controller lastly.
12. Tighten all battery terminal hardware to 98 - 105 in. lbs. (11 - 12 Nm) torque.
13. Protect the battery terminals and battery cable terminals with a commercially available protective coating

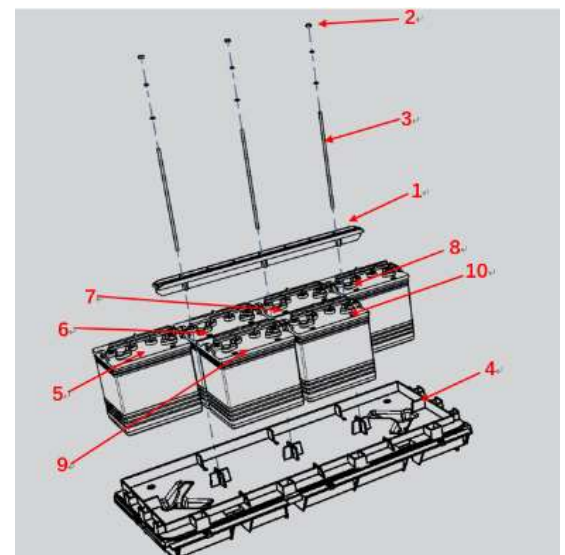

Figure 3 Battery Components

Prolonged Storage

CAUTION

Disconnect the battery charger, controller and other electronic devices for extended storage. All connected electronic components cause the dis-charge of batteries

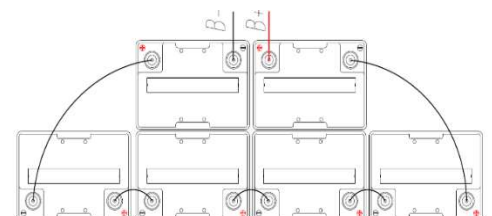

Figure 4 Battery Connections

MAINTENANCE

Read all of SAFETY and this section before attempting any procedure. Pay particular attention to Notices, Cautions, Warnings and Dangers.

NOTICE

In winter conditions, the battery must be completely charged to prevent the risk of freezing. A completely charged battery will not freeze in temperatures above - 75° F (-60° C). Although the chemical reaction is decreased in cold temperatures, the battery must be stored completely charged, and disconnected from circuits that can discharge the battery. The controller must be disconnected from the batteries by disconnecting the battery cables.

For portable chargers, disconnect the charger plug from the vehicle receptacle. For on-board chargers, disconnect the charging harness from the batteries.

The batteries must be cleaned and all deposits neutralized and removed from the battery case to prevent self-discharge. The batteries must be tested or charged again at 0 day minimum intervals.

Battery Charging

The battery charger is designed to completely charge the battery set. If the batteries are severely deep cycled, some automatic battery chargers contain an electronic module that will not activate and the battery charger will not operate. Automatic chargers determine the correct length of charge to the battery set and turns off when the batteries are charged. Always refer to the instructions of the charger used.

CAUTION

Do not overfill batteries. The charge cycle will expel electrolyte and cause component damage.

Before charging, the following must be observed:

- The electrolyte level in all cells must be at the recommended level and above the plates.
- The charging must occur in an area with good ventilation to remove hydrogen gas that is made during the charge cycle. A minimum of five air replacements for each hour is recommended.
- The charger connector components must be in good condition and free from dirt and particles.
- The charger connector must be completely installed in the vehicle receptacle.
- The charger connector and cord set must be protected from damage. The charger connector and cord set must be used in an area where it is not possible for personnel to run over or trip over the cord set.
- The charger automatically turns off during the connect and disconnect cycle so no electrical arc is generated at the DC plug and receptacle contacts.

AC Voltage

The battery charger output is directly related to the input voltage. If the vehicle receives an incomplete charge in a normally adequate time period, low AC voltage can be the cause. Consult an electrician if necessary.

Fault Diagnosis

Fault diagnosis is done for two reasons:

- A battery that performs poorly and is outside of the manufacturers specification must be identified to replace it within the terms of the manufacturer's warranty. Different manufacturers have different requirements. Refer the battery manufacturer or the manufacturer's representative for specified requirements.
- Find the reason a vehicle does not perform adequately. Performance problems can cause a vehicle to run slowly or cannot operate for the time needed.

A new battery must mature before it develops its maximum capacity. Maturing can take 100 or more charge and discharge cycles. After the maturing phase, the older a battery gets, the lower the capacity. The only method to find the capacity of a battery is a load test with a discharge machine. Refer to the discharge machine manufacturer instructions.

A hydrometer is used to identify a poorly performing battery in a set with a low specific gravity. When the particular cell or cells that are the problem are identified, the battery can be removed and replaced. The battery cannot be restored. The individual battery should be replaced with a good battery of the same brand, type and approximate age.

MAINTENANCE

Read all of SAFETY and this section before attempting any procedure. Pay particular attention to Notices, Cautions, Warnings and Dangers.

Leoch Deep Cycle LDC Series Maintenance-free Battery

1. Battery Storage

High temperatures or poor ventilation during storage and transport can lead to higher self-discharge rate, so keep the battery well ventilated and keep it away from open flames, sparks, heat sources, organic solvents, etc.

When storing batteries, they should be removed from the charger or load and stored in a dry, cool environment.

As battery storage requires charge maintenance, it is recommended that batteries should not be stored for longer than the following.

6 months below 25°C 3 months 25°C to 35°C 6 weeks above 35°C

If storage exceeds the above time, it should be charged and maintained.

If you are using a charger, the charger setting parameters should follow the charging curves 4.1 and 4.2 until the charger turns green and then continue float charging for 2-4hrs

If you are using other charging devices, below three charging methods are available.

- 1) Constant voltage 2.40-2.45V/cell charge 8-12hrs;
- 2) Constant voltage 2.45-2.48V/cell charge 6-8hrs;
- 3) Constant current 0.1C(A) Charge for 4-6hrs.

You can also measure open-circuit voltage of the storage battery to determine whether it needs to be charged for maintenance. If open-circuit voltage drops below 2.12V/cell, it is recommended to charge for maintenance.

First in first out management is required during battery storage to avoid battery performance degradation due to a long storage period.

Failure to comply with these storage conditions may result in serious degradation of battery capacity and service life.

2. Use Condition

Environment temperature range: charge 0 ~ 40°C, discharge -20 ~ 55°C, storage The battery can operate in above temperature range, but the standard data is measured at 25°C. The ideal temperature range for charge and discharge is 20 ~ 30°C for best battery performance and life. Use at lower temperatures will shorten discharge times, while use at higher temperature will shorten life and increase potential for thermal runaway.

Batteries should be kept away from open flames, sparks and heat sources. Avoid heat and direct sun explosion.

Keep away from wet places that may be soaked in water.

The battery will release a small amount of gas in normal use, should avoided completely closed place.

Different specifications, different years, different brands, different performance of the battery cannot be mixed, if you need to mix, please contact us for technical guidance.

Notice:

If there is an accidental overcharging, the gas inside the battery will be discharged from the safety valve. Contact the ground before operation to release the static electricity that may exist on the body or clothing.

3. Battery Installation

3.1 Open Box and Check

It is recommended to unpack all single batteries and accessories for inspection and check whether the appearance

MAINTENANCE

Read all of SAFETY and this section before attempting any procedure. Pay particular attention to Notices, Cautions, Warnings and Dangers.

of batteries is damaged before installation, rather than opening and installing them one by one to avoid omission.

Count the number of batteries and whether the accessories are complete according to the attached proposal or goods list.

Batteries are heavy and should be handled or installed with special care. Avoid battery case damage from collision, drop or impact. In absence of battery handle, the battery should be lifted from bottom of the battery.

The insulating terminal cover on battery terminal is intended for protect the terminals during transportation. It can take off during installation.

3.2 Notes before Installation

Before connection, check the battery and confirm that the terminal polarity is correct. Check the configuration number, install by group, cannot be confused. Polish the battery terminals so that they have a metallic shine.

Check all connection cables to make sure they are clean and free from damage.

Insulate metal installation tools (such as wrenches), for example, wrap them with insulating tape. Wear insulated gloves, take off watch, bracelets, rings and other conductors containing metal, to prevent electric shock and cause positive and negative short circuit.

When connecting terminals, ensure that they are securely connected. Tighten each bolt or nut, but do not use too much force to avoid damage.

For the damaged terminal seal structure, see Table 1 for the recommended tightening torque.

Table 1: Tightening torque recommendation table

Bolt Specification	M8
Tightening Torque	13~14.7N·m

Notice:

Loose terminal connections may lead to unstable battery performance or even damage to the battery or cause personal safety.

Avoid mounting the battery close to heat sources (e.g. transformers) and also avoid other equipment cooling fan ports facing the battery.

The battery should be installed avoid proximity to spark generating devices (e.g. fuses).

3.3 Install the Wiring

Install the battery upright, not upside down.

To ensure good heat dissipation, keep space between batteries at least 20mm, heat dissipation holes should be installed around the battery box.

Installation should be anti-vibration, anti-pressure treatment, installation should be firm, in order to prevent battery moving, bumping and mutual friction during use.

The battery box should not be completely sealed. The air hole should not be smaller than 10mm and should not be blocked.

When multiple batteries are used together, connect the batteries first, and then connect the battery pack with the charger or load. Note that the positive terminal of the battery pack should be connected with the positive terminal of the charger or load, and the negative terminal should be connected with the negative terminal

Note: If the battery is not properly connected to the charger or load motor, the charger or load motor may be burned out.

The power test can be performed only after the battery is installed and the total voltage of the battery string is correctly

4. Battery use

4.1 Three Stage Charging

Three-stage charging, the three stages of charging will be automatically switched by the charger.

The first stage (S1), constant current charging, charge at constant current of 0.15-0.18C. The charger will automatically switch to

MAINTENANCE

Read all of SAFETY and this section before attempting any procedure. Pay particular attention to Notices, Cautions, Warnings and Dangers.

the second stage when single cell voltage reaches 2.40-2.45V

The second stage (S2), constant voltage charging, with a single cell voltage of 2.40-2.45V constant voltage charging, when the charging current drops to 0.012- 0.02C, the charger will automatically turn to the third stage, at this time the charger should turn the light (usually turn green, means fully charged).

The third stage (S3), float charging, float charging with single cell voltage 2.28- 2.32V, float charging 2-4hrs can end the charging, at this time the charger should be turned off.

◆ Charging Time Recommendation:

1) Charge above 25°C for about 12hrs. If surface temperature of the battery reach 45°C, stop charging until the temperature drop below 30°C and charging can be continued, otherwise, the battery will be damaged.

2) Charging below 25°C, the battery is stored indoors for 1hr and then charged for about 16hrs.

The charger should have charging temperature compensation function, with 25°C as the base point, for every 1°C increase in ambient temperature, the charging voltage will be adjusted down by 4mV/cell. For 1°C decrease in ambient temperature, the charging voltage will be adjusted up by 4mV/cell.

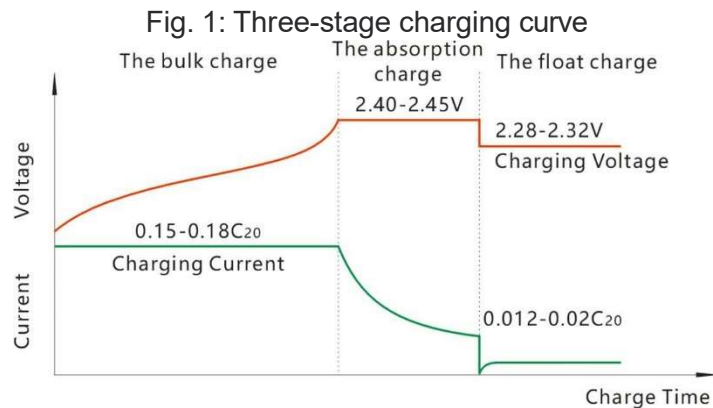

Notice:

In different voltage systems, the current does not change, but voltage should change. For example, when charging at constant voltage, in 48V system, the voltage is 57.6-58.8V at constant voltage charging, and in 24V system, the voltage is 28.8-29.4V. In 48V system, when floating charge, the voltage is 54.7- 55.6V, in 24V system, the voltage is 27.4-27.8V.

4.2 Five Stage Charging

The first stage (S1), charging at constant current of 0.18-0.2C, automatically switches to the second stage when single cell voltage reach 2.40V.

The second stage (S2), charging at constant current of 0.10-0.12C, automatically switches to the third stage when single cell voltage reach 2.47V.

The third stage (S3), charging at constant voltage of 2.47V with current limit of 0.05C, and automatically switch to the fourth stage when charging current drop to 0.01C.

The fourth stage (S4), charging at 0.01C constant current, when the voltage of single cell reach 2.50V, it automatically switches to the fifth stage, at which point the charger should turn the light (usually turns green, which means it is fully charged).

The fifth stage (S5), single cell voltage 2.3V floating charge, floating charge 2- 4hrs can end the charge, at this time the charger should be turn off.

◆ Charging Time Recommendation:

The charging time under the five stage charging curve is for reference, but the charging time of the five stage charging method shall not be less than 12hrs.

MAINTENANCE

Read all of SAFETY and this section before attempting any procedure. Pay particular attention to Notices, Cautions, Warnings and Dangers.

Fig. 2: Five-stage charging curve

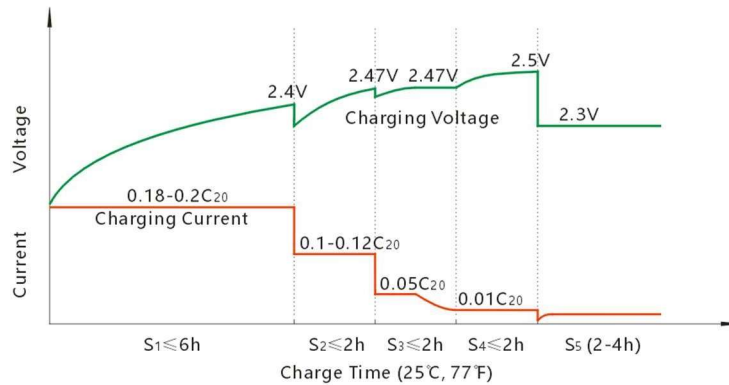

Notice:

In different voltage systems, the current is constant, but voltage should vary. For example, in 48V system, the current should be constant, but voltage should vary as follow: the first stage voltage should be 57.6V, the second and third stage voltage should be 59.3V, the fourth stage voltage should be 60V, and the fifth stage floating charge voltage should be 55.2V.

4.3 Discharge

When the load is operating, the battery is in the discharge stage and over- discharge is strictly prohibited.

To avoid battery over discharge, single-cell protection voltage is 1.75V, 6V battery is 5.25V, 8V battery is 7V, and 12V battery is 10.5V.

See Table 2 for the protection voltage under different voltage systems.

Table 2: Battery power-off protection voltage

Voltage System	2V/Cell	24V System	48VSystem
Power-off protection voltage (V)	1.75V	21V	42V

Notice:

If the battery is used in the vehicle, do not frequently start the high current,

because high current discharge will lead to the positive plate active substances in the battery late in participate in chemical reaction, and accelerate the contraction and expansion, and eventually lead to softening and fall off of the active substances,.

If large current is discharge frequently, it will aggravate softening and falling off of active material of the positive plate inside the battery, and eventually lead to reduction of battery capacity and termination of its life.

Therefore, in daily use of the process, avoid discharge of large current. When starting the vehicle, the accelerator pedal shall be slowly pressed until the vehicle runs at a constant speed.

It is suggested that the starting current should be less than 1.5C. Uniform running current should be less than 0.5C.

The connection wire should be selected according to continuous climbing current or maximum working current of the vehicle load. If the wire diameter is too small, in use will overload heat, or even damage the battery or cause fire accidents.

5.Battery use Prevention

5.1Charging Prevention

The quality of battery charging performance plays an important role in battery life and service performance, which must be pay attention to.

The electrical process is the reverse process of the electrochemical reaction of discharge. If the electrochemical reaction process

MAINTENANCE

Read all of SAFETY and this section before attempting any procedure. Pay particular attention to Notices, Cautions, Warnings and Dangers.

is carried out in an ideal state during charging, the process should be reciprocal reversible reaction, that is, the charged electric quantity is basically equal to the released electric quantity.

If charging parameters do not match or the charger type is not accurate, the charging voltage is too high, the current is large or the charging time is long, the water loss rate of the battery will increase. For the AGM battery, the serious gas evolution will damage the battery and cause early failure of the battery.

① The scouring effect of a large amount of gas on the active material of the electrode plate makes the active material easy to fall off.

② Under higher polarization voltage, the grid of positive plate will be seriously corroded, and make grid deformation, brittle crack, lose the skeleton and conductive function, so that the life of the battery is shortened.

1) If charging is insufficient for a long time, unreacted active substance will produce irreversible coarse lead sulfate grains, that is irreversible sulfate salivation (or sulfurization for short), which will reduce battery capacity, increase internal resistance, increase charging difficulty, and cause early stage of the battery invalid.

2) Therefore, the battery should be fully charged to prevent irreversible sulfation.

5.2 Discharge Prevention

The protection voltage set for the battery unit is 1.75V/unit, when the power meter remind of low voltage or there is power failure during usage of the vehicle, do not use battery's rebound voltage continue driving the vehicle. The battery voltage at this time is a false voltage, continued use will lead to over-discharge of the battery pack, excessive deep discharge will lead to shedding and softening of active material of the battery positive plate, and also intensify the corrosion, eventually lead to reduction in battery capacity and battery life.

Therefore, battery should be charged before low voltage alarm of the vehicle meter, or battery should be replaced at the recharging station. The replaced battery should be charged in time, if idle for a long time, it will also lead to reduction of battery capacity.

5.3 High and Low Temperature Prevention

When batteries are operated in high temperature season, there is risk of overcharging.

When battery temperature increases, the activity of various active substances increases, the positive electrode oxygen evolution potential decreases, the negative electrode hydrogen evolution potential also falls down. Therefore, the ability to accept charging increases, charging reaction speed up, and charging current is big, which requires low voltage for charging the battery full. To prevent high charging voltage, battery temperature should lower down to ensure good heat dissipation.

Keep away from heat sources, do not charge under the sun, and avoid charging immediately after sun exposure.

In low temperature environment, various active substances of battery are less active, the positive electrode charging acceptance capacity is reduced, and the negative electrode charging is affected by the swelling agent, and the low temperature charging acceptance capacity is even lower.

Therefore, charging at low temperature have the problem of poor charging acceptability and insufficient charging, which requires increase charging voltage and prolong charging time. In particular, charging should be placed in a warm environment, as described in 4.1, and stored indoor for 1hr before charging. It is beneficial to ensure sufficient charge, prevent irreversible sulfation and extend the life of battery.

5.4 Prevent Short Circuit

Under battery short circuit state, its short circuit current can reach thousands of amperes. Therefore, the connection part will produce a lot of heat when short-circuiting, which will fuse the connection, damage surrounding sealant or shell, and cause hidden dangers like leakage.

Therefore, the battery must not short circuit, it should be more careful during installation or usage. All tools used need take insulation measures, the connection wire should be connected to the appliances outside the battery first, after checking no short circuit, finally connect to the battery.

MAINTENANCE

Read all of SAFETY and this section before attempting any procedure. Pay particular attention to Notices, Cautions, Warnings and Dangers.

Battery terminal screws should be covered with matching insulation sleeves or take other insulation measures.

Wiring specifications, should be well insulated to prevent overlapping compression and rupture.

5.5 Prevent Loose Connections

If the terminal is not firmly connected to the connection strip, and the degree is light, there will be poor conductivity, causing the contact part heating, large wire loss, low output voltage, and affect the motor power, so that the mileage is reduced or cannot run normally.

If the terminal parts are not in contact (most of the faults are in the terminal and the connecting part), the terminal cause large amount of heat, affect the combination of terminal and sealant. If the situation kept for a long time, it will cause terminal leakage phenomenon. If in the driving or charging process, the loose connection may produce spark, or even safety accidents.

Electric vehicles have to bear strong vibrations during operation. Therefore, all connections should be reliable. Ensure that no accidents occur during the driving process.

5.6 Prevent Exposure to the sun

Exposure to the sun will increase temperature of the battery, increase internal pressure of the battery, and force the safety valve open, increase water loss, and reduce the gas evolution potential of the battery. Therefore, shorten the battery life. It should also be prevented from charging in the sun.

5.7 Charger Prevention

The charger control must be accurate to have a stable voltage and current, otherwise it will damage the battery. The following are examples of battery damage caused by chargers.

- 1) If output voltage or output maximum current is too low, it will shorten the life of the battery. If used for a long period of time, it can leads to sulfation of the pole plates and reduction in battery capacity.
- 2) If output voltage of charger is too high, it will cause battery overcharge and lose water, which will lead to reduction in capacity, shortened battery life and, even bulge deformation.
- 3) The rectifier effect of charger is poor, ripple coefficient is large, more than 2%, will lead to battery self-discharge, charging heat and even bulging.
- 4) Short circuit problems within the charger, such as short circuit at the output end, damaged or uninstalled diodes prevent backflow, can cause the charger not to charge. The battery will be severely over-discharged until the end of its life.

If the charger is unstable, which will lead to battery damage.

- 5) If the charger is unstable, which will lead to battery damage.
- 6) After discharge, the battery should be charged in time, otherwise the battery will be sulfated and its capacity will decrease.
- 7) The charging voltage of the special charger for flooded battery is high. Charging the AGM battery will cause the AGM battery overcharge and swell.

6. Battery Maintenance

6.1 Basic Maintenance Knowledge

The service life of battery is not only related to the quality of battery products and the system configuration of electric vehicles, but also has a great relationship with the use and maintenance of consumers. Therefore, it is necessary to master some basic knowledge of battery maintenance.

- 1) The battery shall not be stored under power loss. If it is used up and idle for a few days before charging, the plate is prone to sulfuric acid salinization and the capacity will decrease. Battery deficit storage will seriously affect the service life, the longer the idle time, the more serious the damage.
- 2) Regular inspection. If the initial exercise mileage of the new electric car is 60km, there is serious reduction in capacity within three months, such as 30km below, at this time multimeter can be used to check single voltage of the battery. Generally, fully charged single cell voltage can reach 6.55V(6V battery), 8.73V(8V battery) and 13.1V(12V battery). If one of the battery voltage is significantly lower than the other batteries, the backward battery may have internal single block

MAINTENANCE

Read all of SAFETY and this section before attempting any procedure. Pay particular attention to Notices, Cautions, Warnings and Dangers.

short circuit, and needs replacement, so as not to damage rest of the batteries. On the other hand, charging parameters of the charger should also be checked.

3) Check battery connection cable once a week. The driving vibration of vehicle may cause the bolt or nut of the connection cable get loose. It needs to be checked regularly. If loosend bolt or nut is found, fasten it immediately

4) When starting the electric vehicle, the accelerator pedal shall be slowly pressed to start the vehicle with a small current until the vehicle runs at a constant speed. If it is started, press the accelerator pedal to the bottom. At this time, the motor current will increase rapidly, so that the battery will discharge fast and the voltage will drop quickly. The smaller the discharge depth, the longer the battery life. So reduce the discharge of high current can extend the battery life, and increase the mileage.

5) In winter, it is normal for the battery capacity decrease with the decrease of temperature. Take 25°C as the standard, the capacity is about 85% at 0°C.

6) The charger should be chosen to match the battery model. When charging, it should avoid high temperature and humidity. Do not let water flow into the charger to avoid short-circuit accident. The charger should have temperature compensation function. At 25°C base point, for every 1°C increase in ambient temperature, the charging voltage will reduced by 4mv/cell. When the ambient temperature decreases by 1° C, the charging voltage increases 4mv/cell.

7) Keep the battery surface clean for a long time, and the vehicle should be parked in a cool, ventilated and dry place.

8) When the vehicle needs to be placed for long time, the battery must be fully charged first, and the battery should be fully charged once a month. Or, under the guidance of professional personnel, remove one of the connection cables from the battery pack, so that the battery is in the open state and can be stored for longer time, and refer to "1. Battery Storage" for charge the battery

6.2 Routine Maintenance Items

Item	Period	Content	Standard	Maintenance
Battery single cell voltage	One month	When the battery group is fully charged, use multimeter measure voltage of a single cell	Single voltage difference, 6V battery should be less than 0.2V, 8V battery should be less than 0.3V, 12V battery should be less than 0.4V	Remove the backward single cell and charge it separately for maintenance. If the voltage still deviates from the standard, replace the cell with low voltage
Battery appearance	One month	Visually check battery case and cover for acid leakage, deformation, cracks or damage	Appearance is normal	If the appearance is abnormal, first confirm the cause. If it affects normal use, replace the battery.
		Visually check the battery surface for dust and stains	Appearance is clean	Clean the dust and stains on battery surface with a dry cloth
		Visually check whether there is rust or corrosion in the connector or terminal	No rust, no corrosion	Slight rust or corrosion, use a steel brush to remove rust, and apply rust inhibitor. For severe rust or corrosion, replace with a new connector or battery

MAINTENANCE

Read all of SAFETY and this section before attempting any procedure. Pay particular attention to Notices, Cautions, Warnings and Dangers.

Connector	One week	Use wrench to check whether the bolts and nuts are loose	Strong connection	Tighten immediately if it gets loose.
-----------	----------	--	-------------------	---------------------------------------

Notice:

Removal or replacement of the battery involved in the above battery maintenance, and removal of rust on the connector or terminal requires professional operation. Consumer operation can cause danger, please contact the supplier for maintenance.

6.3 Battery replacement and recycling

Batteries are consumables and have certain life cycle. After a period of charging and discharging cycles, the capacity will gradually decrease, and the mileage of the electric vehicle will be shortened. However, if capacity of the battery falls below 50% of nominal value within the warranty, the battery is deemed to have failed, please seek help from the supplier. If the capacity of the out-of-warranty battery drops below 50%, please consider replacing it with a new battery.

The battery is marked with recycling symbol, and the scrapped battery should be recycled by a formal recycling organization, or it can be returned to the supplier for unified recycling. Do not throw it into the trash can or discard it at will, it will cause environmental pollution.

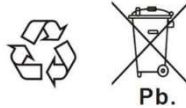

7 Common Battery Failures

7.1 Battery Leakage

1) Battery Leakage

- Check whether the seal between the cover and the bottom slot is cracked due to poor sealing or collision, resulting in battery leakage.
- Check whether the safety valve leaks acid.
- Check whether there is acid leakage outside the terminal.
- Check whether the battery case cracked, damaged or leaked. The leaking battery can not be used and should be replaced with a qualified battery. If you cannot determine, please seek supplier for help.

2) Charging Heat

- The battery heats up during the charging process. Check the charging voltage and current of the charger. If the voltage is too high or the current is too high, the temperature of the battery will rise during charging process, and even swollen.
- Check whether the battery connector is firmly connected with the terminal. Poor connection may also cause battery heating and burn out the terminal or connector during the charging process.

If the cause of the heating is found and the temperature of the battery does not exceed 50°C, wait until the temperature of the battery is lower than 30 °C, and there is no potential for heating problem, you can continue use the battery.

If the cause of heating is not found, seek help from the supplier.

If temperature of the battery exceeds 50°C or the battery swollen and deformed, it cannot be used anymore and should be replaced with a qualified battery.

3) Battery Short Circuit

If single cell short circuit appears inside the battery, the open circuit voltage is about 2V lower than normal battery. It will react strongly to battery charging, or the heat is obvious when a single cell is charged.

If the short-circuited battery cannot be used any longer, it should be replaced by a qualified battery.

4) Battery Open Circuit

MAINTENANCE

Read all of SAFETY and this section before attempting any procedure. Pay particular attention to Notices, Cautions, Warnings and Dangers.

a. The battery have voltage, but the whole battery group cannot be charged or discharged. The internal resistance meter can be used to check the single battery with open circuit, because the internal resistance of the open circuit battery is very large.

b. Open circuit state: If the battery has no voltage, it is open circuit.

The open circuit battery cannot be used any longer, it should be replaced with a qualified battery.

5) Irreversible sulfation

a. When the plate is severely sulfated, the voltage rises quickly, the gas precipitates prematurely, and the temperature rises quickly.

b. The battery discharge rapidly until reach the final voltage, and the battery capacity decreases.

c. Through dissection, the positive and negative plate are found hard and brittle, and the separator is adhered, there are white crystals on the surface.

Check whether the battery is undercharged for long time or stored in a deficit.

Slightly sulphated batteries will repair in the process of use, but seriously sulphated batteries, the capacity has decreased significantly, can not continue to be used, and should be replaced with qualified batteries.

6) Single Battery Capacity is low

In the same group, when the voltage a single battery drops faster than the other batteries, and drop faster to the protective voltage(1.75V/cell). The battery is determined to be backward.

If the battery capacity backward, see 6.2 for maintenance.

Notice:

If the faults found are not included in the above, please seek help from the supplier

MAINTENANCE

Read all of SAFETY and this section before attempting any procedure. Pay particular attention to Notices, Cautions, Warnings and Dangers.

Hydrometer

A hydrometer is used to test the state of charge of a battery cell. This is performed by measuring the density of the electrolyte, which is accomplished by measuring the specific gravity of the electrolyte. The greater the concentration of sulfuric acid, the denser the electrolyte becomes.

The higher the density, the higher the state of charge.

WARNING

To prevent battery explosion, never insert a metal thermometer into a battery. Use a hydrometer with a built in thermometer that is designed for testing batteries.

Specific gravity is the measurement of a liquid that is compared to a baseline. The baseline is water which is assigned a base number of 1.000.

The concentration of sulfuric acid to water in a new golf car battery is Weight 1.280 which means that the electrolyte weighs 1.280 times the weight of the same volume of water. A fully charged battery will test at 1.275 - 1.280 while a discharged battery will read in the 1.140 range.

NOTICE

Do not perform a hydrometer test on a battery that has just been watered. The battery must go through at least one charge and discharge cycle in order to permit the water to adequately mix with the electrolyte.

The temperature of the electrolyte is important since the hydrometer reading must be corrected to 80° F (27° C). High quality hydrometers are equipped with an internal thermometer that will measure the temperature of the electrolyte and will include a conversion scale to correct the float reading. It is important to recognize that the electrolyte temperature is significantly different from the ambient temperature if the vehicle has been operated.

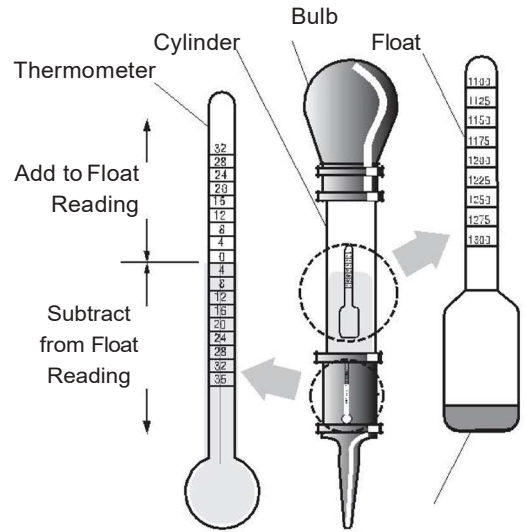

MAINTENANCE

Read all of SAFETY and this section before attempting any procedure. Pay particular attention to Notices, Cautions, Warnings and Dangers.

Using A Hydrometer

1. Draw electrolyte into the hydrometer and release it several times to permit the thermometer to adjust to the electrolyte temperature and note the reading. Examine the color of the electrolyte. A brown or gray coloration indicates a problem with the battery and is a sign that the battery is nearing the end of its life.
2. Draw the minimum quantity of electrolyte into the hydrometer to permit the float to float freely without contacting the top or bottom of the cylinder.
3. Hold the hydrometer in a vertical position at eye level and note the reading where the electrolyte meets the scale on the float.
4. Add or subtract four points (.004) to the reading for every 10° F (6° C) the electrolyte temperature is above or below 80° F (27° C). Adjust the reading to conform with the electrolyte temperature, e.g., if the reading indicates a specific gravity of 1.250 and the electrolyte temperature is 90° F (32° C), add four points (.004) to the 1.250 which gives a corrected reading of 1.254. Similarly, if the temperature was 70° F (21° C), subtract four points (.004) from the 1.250 to give a corrected reading of 1.246.
5. Test each cell and note the readings (corrected to 80° F or 27° C). A variation of fifty points between any two cell readings (example 1.250 - 1.200) indicates a problem with the low reading cell(s).

As a battery ages the specific gravity of the electrolyte will decrease at full charge. This is not a reason to replace the battery providing all cells are within fifty points of each other. Since the hydrometer test is in response to a vehicle exhibiting a performance problem, the vehicle should be recharged and the test repeated. If the results indicate a weak cell, the battery or batteries should be removed and replaced with a good battery of the same brand, type and approximate age.

Battery Charger Maintenance

Connect the charger plug into the vehicle receptacle and wait for the relay to activate.

Move the plug back and forth in the receptacle. If the charger turns off, check the plug for a broken red wire in the DC cord.

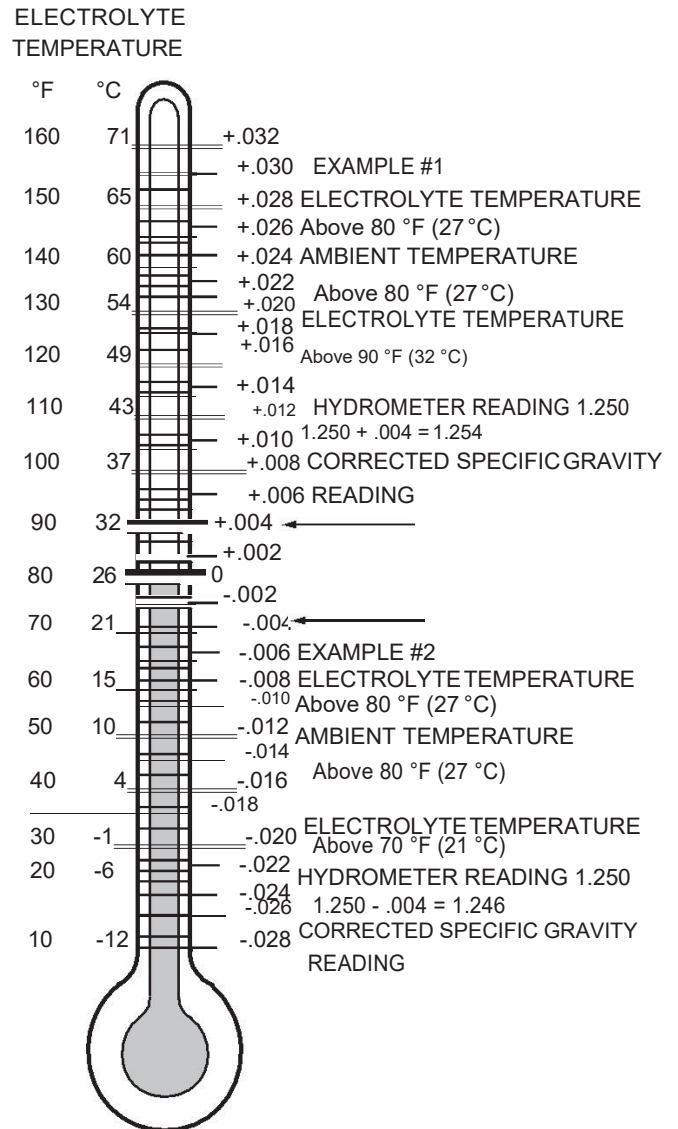

PERIODIC SERVICE SCHEDULE

Read all of SAFETY and this section before attempting any procedure. Pay particular attention to Notices, Cautions, Warnings and Dangers.

PERIODIC SERVICE SCHEDULE

PERIODIC SERVICE SCHEDULE

▲General maintenance items

★Advanced maintenance items

User regular maintenance details					
Maintenance item	Weekly (Or 20H)	Per month (Or 80H)	Quarterly or 250H)	Half a year (or 500H)	Every year (or 1000H)
Check tire pressure	▲				
Check whether the tires are abnormally	▲				
Check the tightening of the axle bolts and wheel nuts	▲				
Tire rotation			▲		
Check the service brake and parking brake performance		▲			
Check the wear of the brake shoes			▲		
Check the free travel and work of the steering wheel			▲		
Check the tightness of the ball heads of the steering horizontal and straight tie rods		▲			
Check the fixing nut of the steering gear spline coupling		▲			
Check the tightness of the steering mechanism and bracket		▲			
Check and adjust the front wheel toe			▲		
Check the connection and tightening of the steering components			▲		
Check the tightness of the leaf spring U- bolt			▲		
Check the tightness of the front shock absorber			▲		
Check the battery electrolyte level	▲				
Check the battery electrolyte density	▲				
Check whether the battery pole is loose		▲			
Wash battery poles with water		▲			
Check the working condition of the relay		▲			
Clean and fix line joints		▲			
Check the wear of the brake friction lining			▲		

Check the wear of the brake friction lining		▲			
Check the work of the rear axle main reducer and bearings					★
Check and replace transmission gear oil					★
Check and replace the rear axle gear oil		▲ (After the first month or after the closing period)			★
Check the work of the rear axle main reducer and bearings		▲ (After the first month or after the closing period)			★
Check the bolts and nuts of the motor			▲		
Clean and lubricate the front wheel bearings (with gear lubricant)					★
Check motor carbon brush			▲		
Lubricate other parts (use general oil)				★	

*Use only distilled or purified water that is free of contaminants to fill batteries.

NOTE: Some maintenance items must be serviced more frequently on vehicles used under severe driving conditions.

PERIODIC SERVICE SCHEDULE

Read all of SAFETY and this section before attempting any procedure. Pay particular attention to Notices, Cautions, Warnings and Dangers.

Analysis and elimination of common faults

Vehicle maintenance and troubleshooting qualifications, site requirements, safety precautions Same as vehicle maintenance requirements.

Failure phenomenon	possible reason	Solution
The vehicle cannot be driven	Operation procedure error	Please see the operation guide for correct operation
	Terminal oxidation (corrosion)	Disconnect the power supply, remove the nut, clean the terminal and install it
	Low battery	Charging
	Damaged direction switch	Replace
	Damaged accelerator	Replace
	Motor damage	Replace
	Damaged direction contactor	Replace
	Loose wire harness connector	Replace
When the vehicle is climbing, it travels slowly to a stop	Whether the vehicle is overloaded, causing the controller temperature to be higher than 75°C and shutting down for protection	Reduce the vehicle load and let the controller cool down
When the vehicle is running, release the accelerator pedal and the vehicle will not decelerate	The accelerator pedal spring is broken, causing the pedal to be unable to reset	Turn off the power lock or press the emergency power off button, and then contact the manufacturer
Turn on the electric lock, the auxiliary electric equipment of the whole vehicle does not work	Burned fuse or poor electrical contact	Replace the fuse, repair the relay
Open the electric lock, the power meter does not display (LED does not light up)	The plug-in of the alarm circuit is loose	Locking plug-in
	Blown fuse	Replace the fuse
Tire deviation	Tire pressure imbalance	Inflate to balance tire pressure
	Uncorrected front and rear wheels	Correcting the wheel
Difficulty steering	Insufficient tire pressure	Aerate
	Lack of lubrication on the steering linkage shaft	Add lubricating oil
	Damage to the steering king pin or ball joint	replace
Oversteer	Damaged ball joint	replace
	The steering gear is under-adjusted or worn	Debug or replace
	Steering linkage shaft loose	Fasten
	Low battery	Recharge
	Damaged transmission gear	replace

Lack of motivation and slow response		
	The speed control system is faulty	Commissioning and maintenance
Rear wheel bearing oil leakage	Damaged wheel bearings or washers	replace
	Overfilled engine oil	Release the right amount
Abnormal noise	Worn transmission gears or bearings	replace
	Wear of front axle bearing or rear axle bearing	Adjust or replace
	Damaged motor bearings	replace
Insufficient braking force	Brake wear	replace
The possible reasons are for reference only, and do not include all the reasons leading to the above failures		

Read all of SAFETY and this section before attempting any procedure. Pay particular attention to Notices, Cautions, Warnings and Dangers.

Notes:

A large grid of graph paper for taking notes. The grid consists of 20 columns and 30 rows of small squares, providing a structured area for writing or drawing.

Read all of SAFETY and this section before attempting any procedure. Pay particular attention to Notices, Cautions, Warnings and Dangers.

APPENDIX A

DECLARATION OF CONFORMITY

|

|

NOTICE

Read the following warnings before operating vehicle:

WARNING

When you leave the vehicle, turn the key to the OFF position and remove the key from the vehicle.

Drive the vehicle only as fast as terrain and conditions allow. Consider the terrain and traffic conditions. Consider environmental conditions that change the terrain and your ability to control the vehicle.

Do not drive fast downhill. Sudden stops or change of direction can cause a loss of control. Use the brake to control the speed of the vehicle when you drive down a slope.

When possible, stay in approved areas and do not drive on steep slopes.

Always keep feet, legs, hands and arms inside vehicle.

Do not drive on rough terrain.

Before you drive in the reverse direction, make sure the area behind the vehicle is clear.

Make sure the direction selector is in the correct position before you press the accelerator pedal.

Decrease speed before and during turns.

Make sure you completely stop the vehicle before you move the direction selector.

See GENERAL SPECIFICATIONS for the vehicle load and seat capacity.

NOTICE

Read the following information and warnings before operating vehicle:

In any product, components will eventually fail to perform properly as the result of normal use, age, wear or abuse.

Normal use, age, wear or abuse can cause some components on the vehicle to fail. The manufacturer cannot know all possible component failures or the methods that failures can occur. A vehicle in need of repair does not operate correctly and can be dangerous.

Be careful when you service the vehicle. Be aware of your safety and the safety of other people in the area. Some components are heavy, spring loaded, corrosive, explosive, can cause high amperage or get hot. Battery acid and hydrogen gas can cause injury. Do not put your hands, face, feet or body in a location that can expose them to injury if an unexpected situation occurs.

Always use the correct tools shown in the tool list and wear safety equipment.

WARNING

Remove all jewelry before you service the vehicle.

Do not allow loose clothing or hair to contact the moving parts.

Do not touch hot objects.

The drive wheels must be lifted and supported on jack stands before you do any service to the powertrain when the motor is in operation.



When you service the vehicle, always wear eye protection. Be careful when you do work around batteries or you use solvents or compressed air.

Use wrenches with insulation to decrease the risk of a short-circuit if a wrench falls across the battery terminals. A battery short-circuit can cause an explosion.

To prevent the risk of battery explosion, keep all flammable materials, open flames or sparks away from the batteries.

Hydrogen gas is made as batteries are charged. Do not charge batteries without good ventilation.

