

INSTRUCTION MANUAL

AIR 67

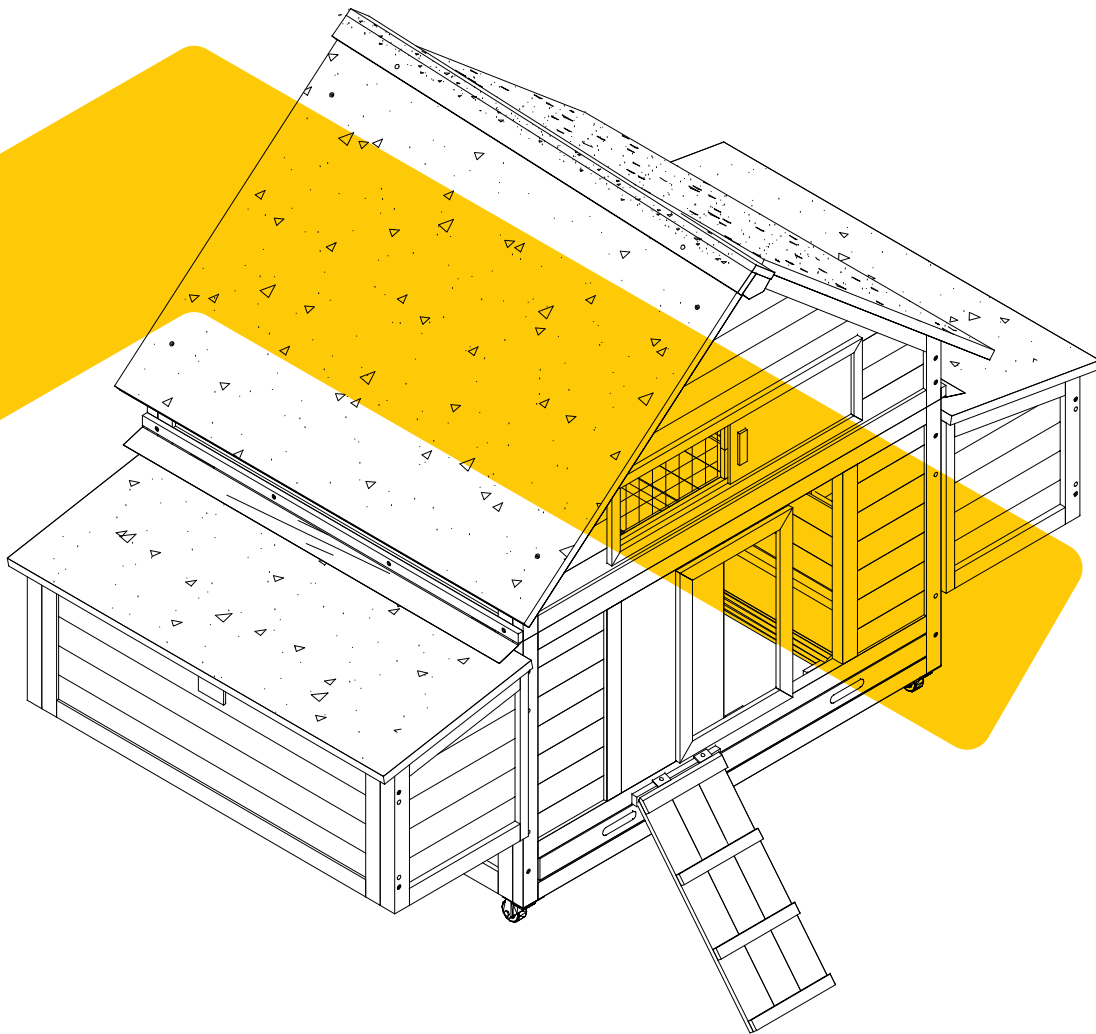



NOTICE

Please retain these instructions for future

- Firmly secure all bolts, screws and knobs before use.
- Reconfirm that all bolts, screws, and knobs are secure every 90 days.
- Fasten screws loosely during initial assembly. Do not fully tighten screws until the item is completely assembled.
- Do not use or store this item in the proximity of open flame or flammable/combustible chemicals.
- Be aware that some parts are heavy and have sharp edges.
- Be aware that moving parts can injure, crush and cut.
- If any parts are missing, broken, damaged, or worn, stop using this product until repairs are made and/or factory replacement parts are installed.
- Do not use this item in a way inconsistent with the manufacturer's instructions as this could void the product warranty.

TOOLS REQUIRED



PHILLIPS
SCREWDRIVER

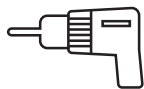

DRILL
(RECOMMENDED)



2PERSON
ASSEMBLY



APPROXIMATELY
60MIN. ASSEMBLY

HARDWARE

M6.0x55 mm BOLT
8PCS+1 spare



P1

M3.5x60 mm SCREW
20PCS+1 spare



P2

M3.5x40 mm SCREW
12PCS+1 spare



P3

M3.5x35 mm SCREW
8PCS+1 spare



P4

M3.5x25 mm SCREW
24PCS+1 spare

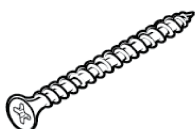

P5

M3.0x16 mm SCREW
14PCS+1 spare



P6

Lock
1PC

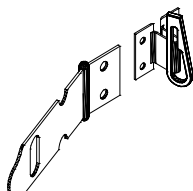

P7

Spacer
12PCS

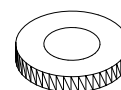

P8

HARDWARE

Connect pieces

2PCS

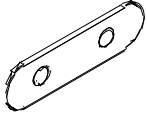

P9

PARTS

Upper panel-front and back
2PCS

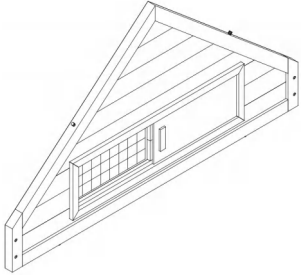

A

Down panel- Front side
1PC

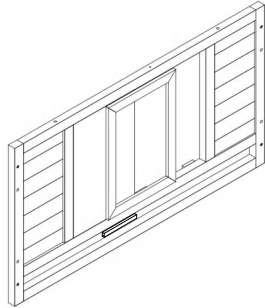

B

Down panel- Back side
1PC

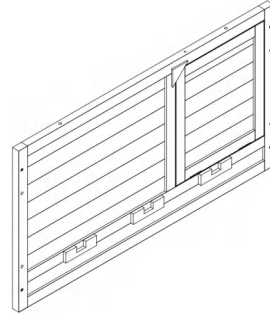

C

Side Panel
2PCS

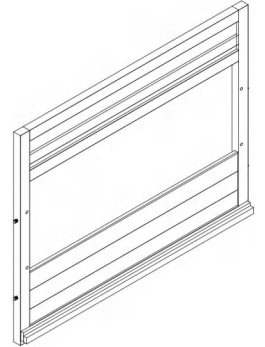

D

Casters without brake
2PCS

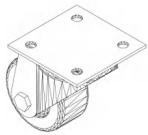

E

Casters with brake
2PCS

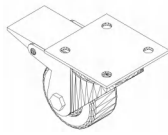

F

Tray
1PC

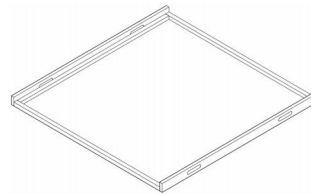

G

Perch
3PCS

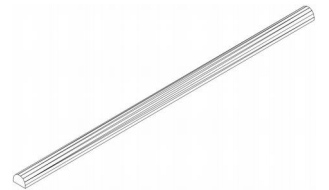

H

Left panel of nesting box
2PCS

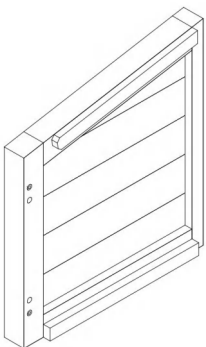

I

Right panel of nesting box
2PCS

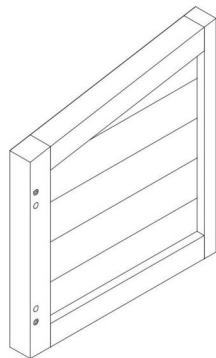

J

Front panel of nesting box
2PCS

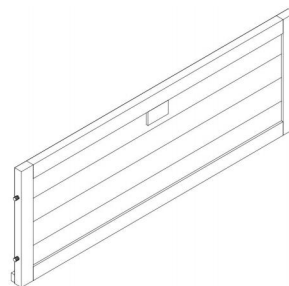

K

Bottom panel of nesting box
2PCS

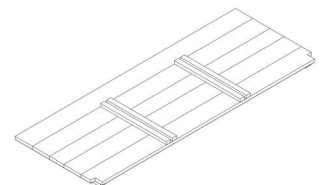

L

PARTS

Divider
2PCS

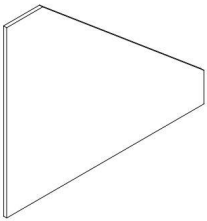

M

Roof of nesting box
2PCS

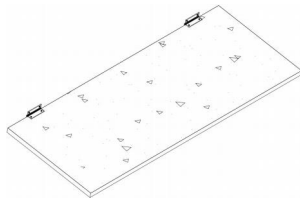

N

Roof
2PCS

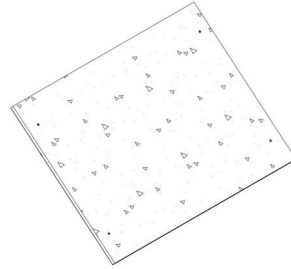

O

Roof cap
1PC

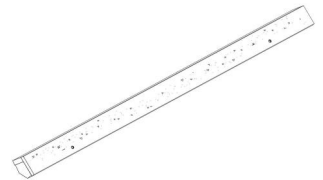

P

PVC Waterproof Strip
2PCS

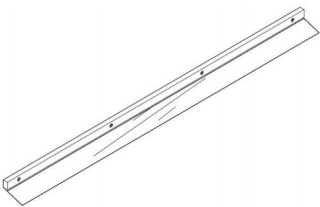

Q

Ramp
1PC

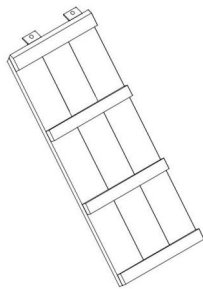

R

Bottom plate
1PC

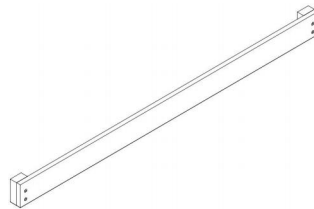

S

(Only need for connecting
with the coop AIR60)

PRODUCT ASSEMBLY

01 Attach Part A,B,C to the side panel Part D by P2x16; then connect the Part A to B&C by P2x2.

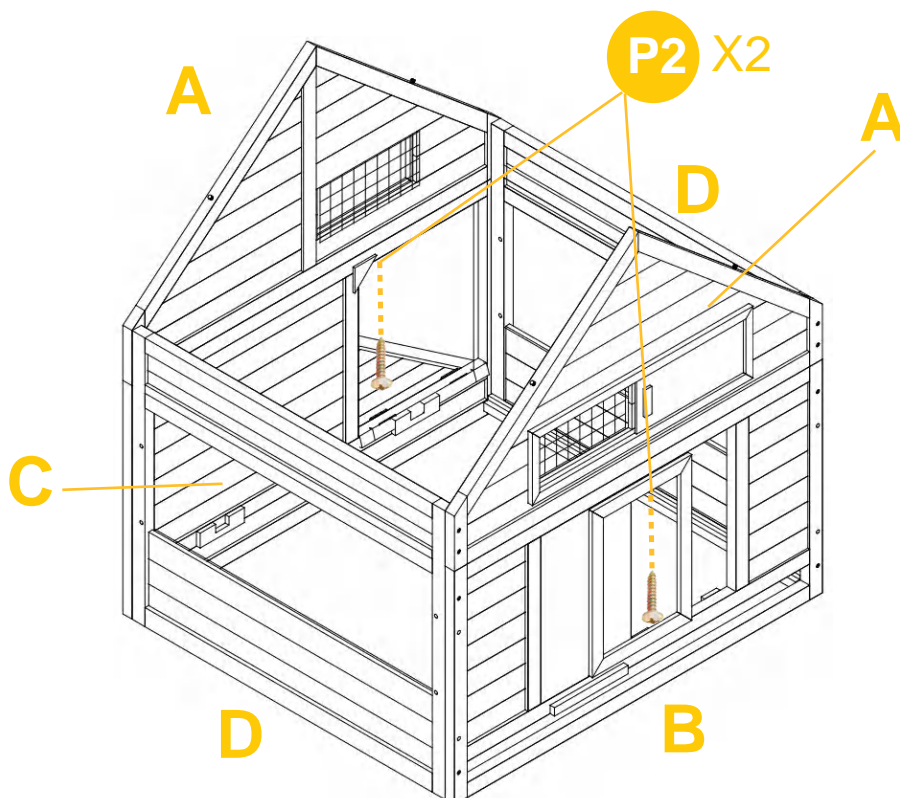
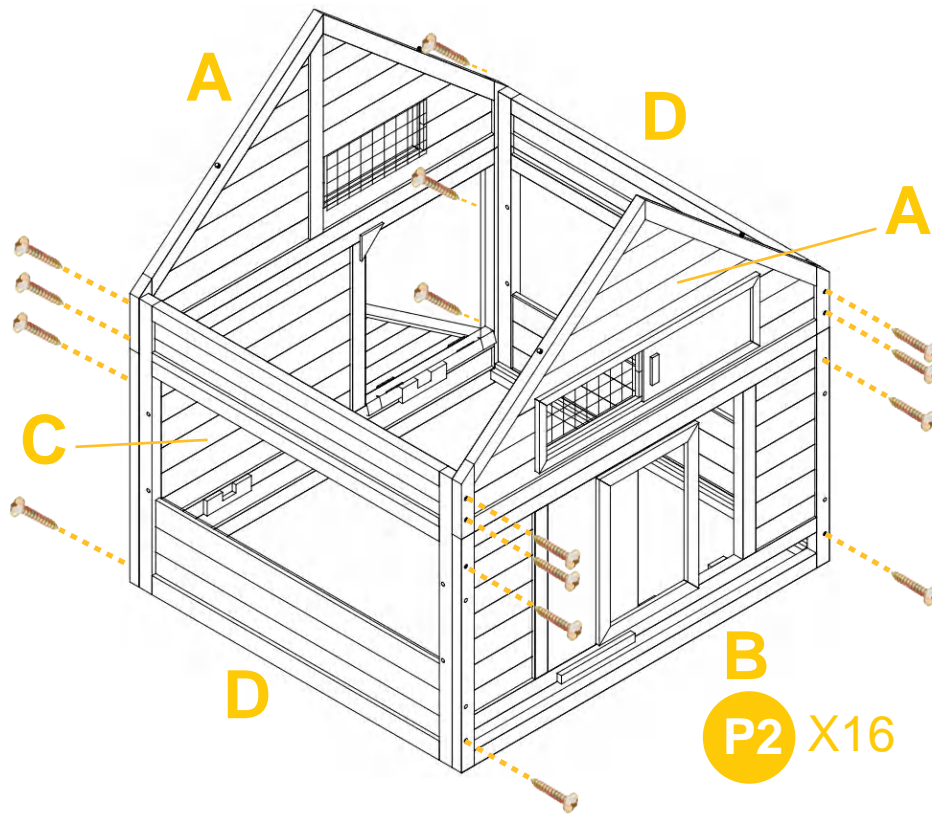

PRODUCT ASSEMBLY

02

Screw two casters without brake Part E to the front of coop legs by P5x6 using the P8 spacer.
Screw two casters with brake Part F to the back of coop legs by P5x6 using the P8 spacer.

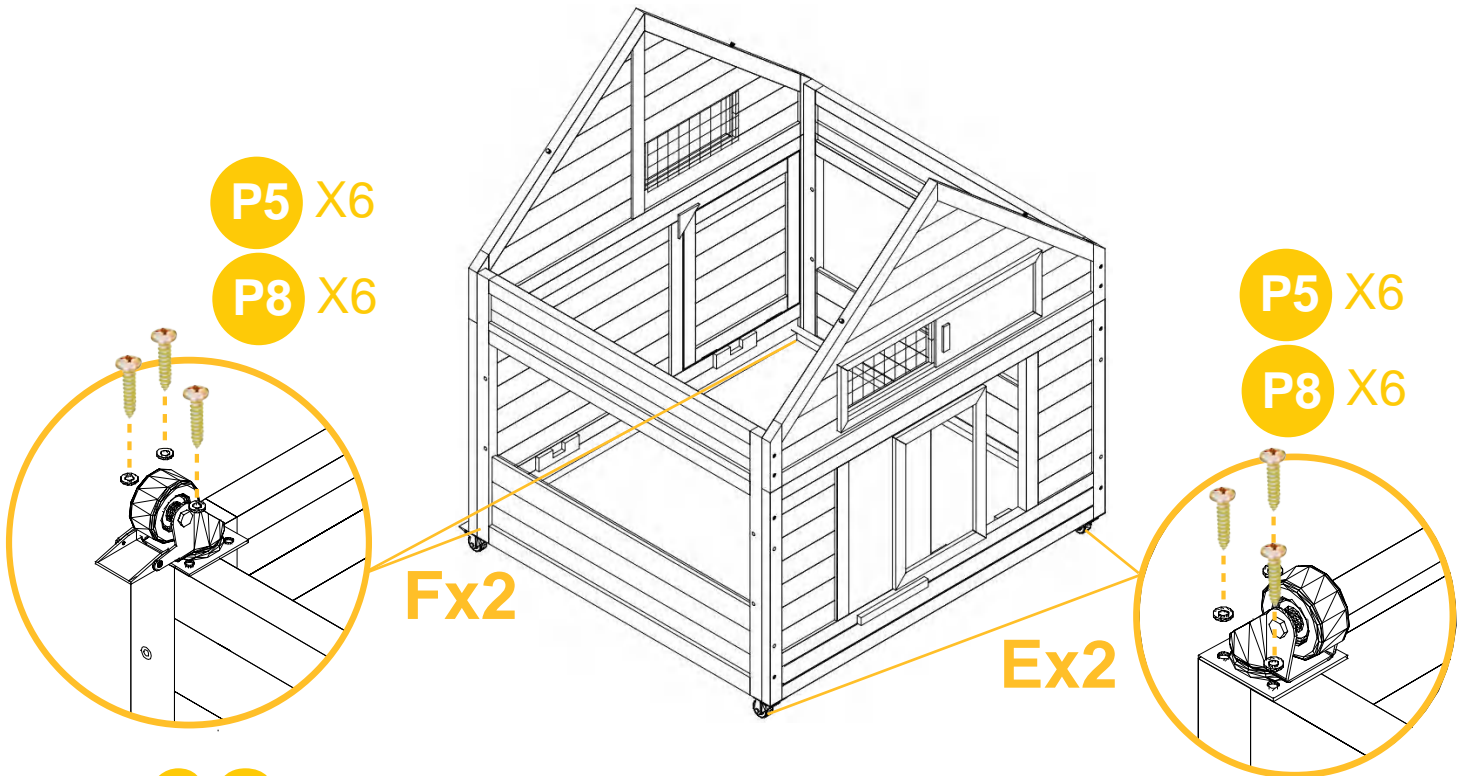

03

Insert the perches 3xPart H into the slots inside the front and back panel of coop.
Slide in the tray.

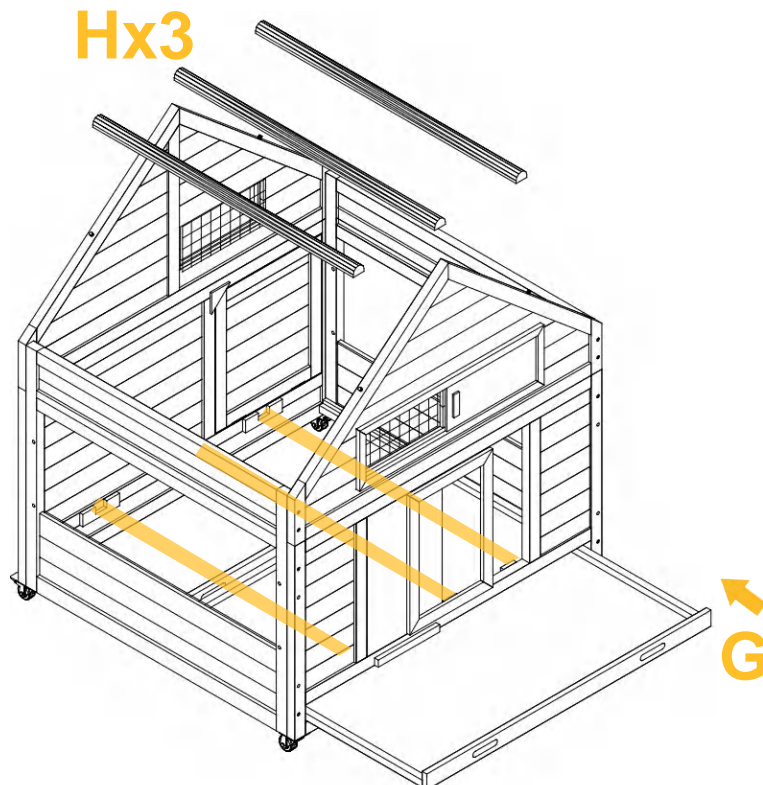

PRODUCT ASSEMBLY

04 Attach the side panels of nesting box Part I & J to the side of coop by bolt P1x4 on each side.

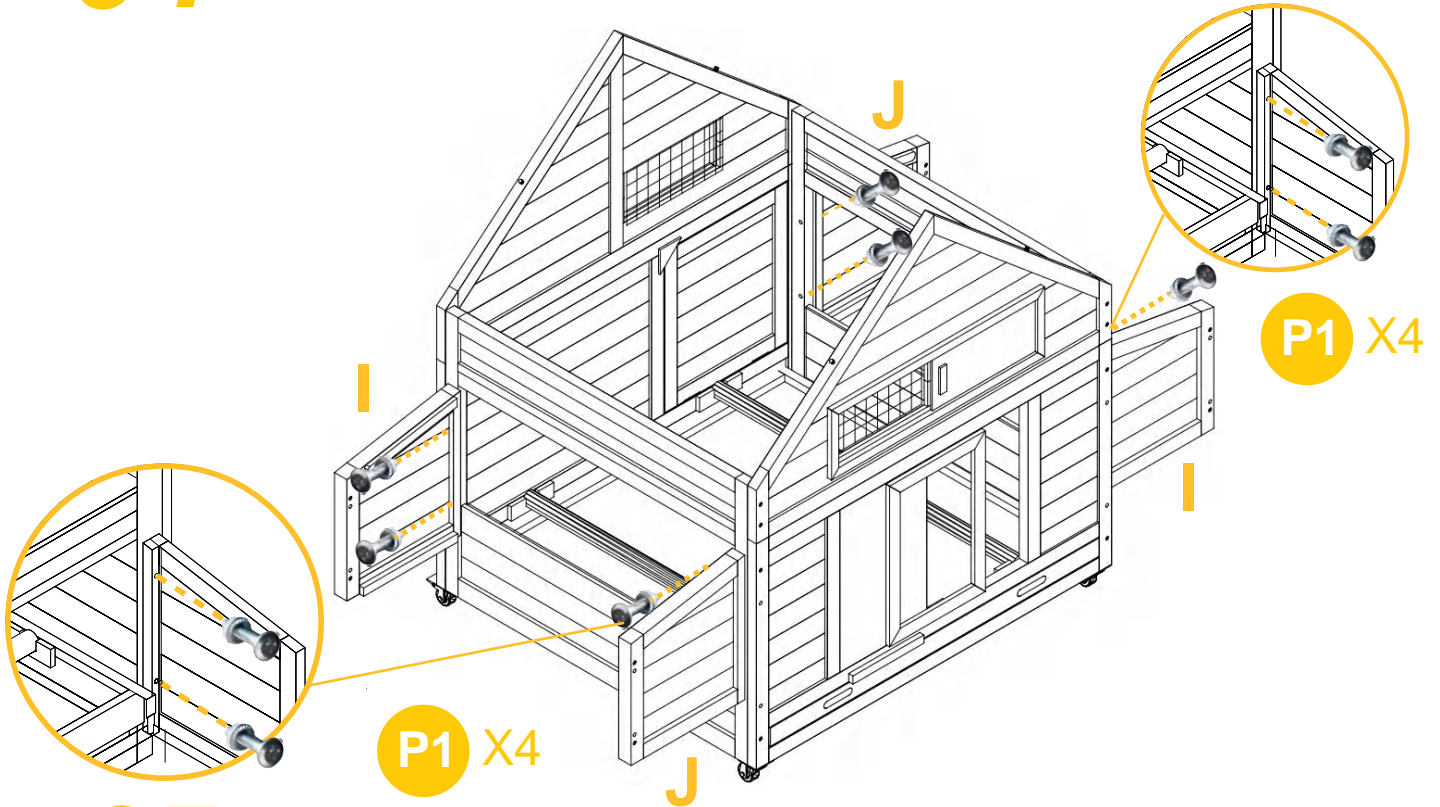

05 Attached the front panel of nesting box Part K by P3x4 on each side.

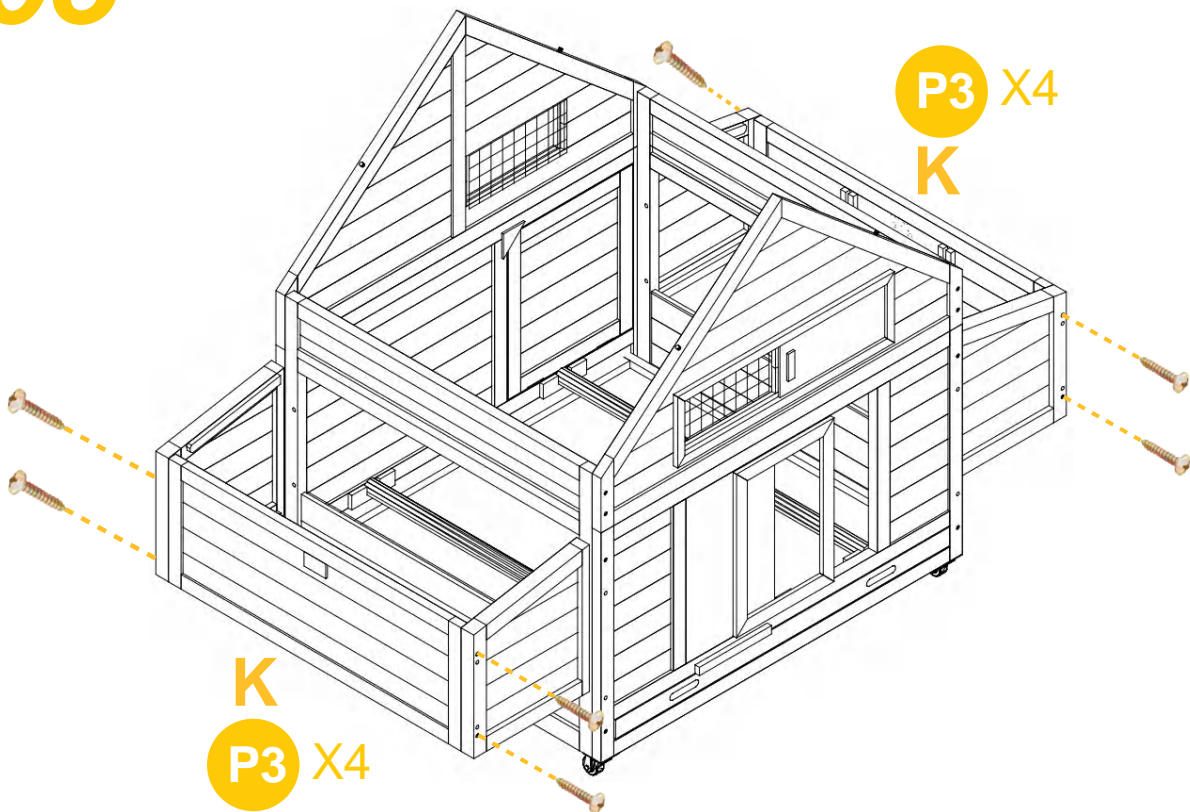

PRODUCT ASSEMBLY

06 Drop in the bottom panel of nesting box Part L.
Slide in the divider Part M on each side .

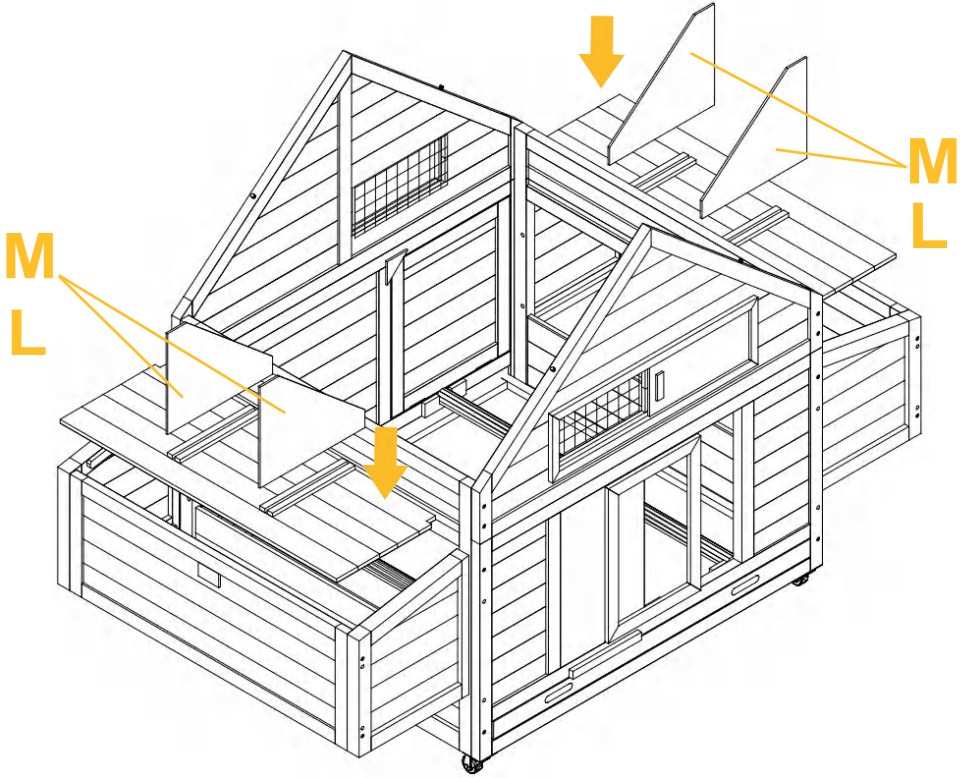

07 Attach the roof of nesting box 2xPart N to the nesting box by 4XP6 screws on each side.
Make sure the lock is functioning properly before locking the roof.

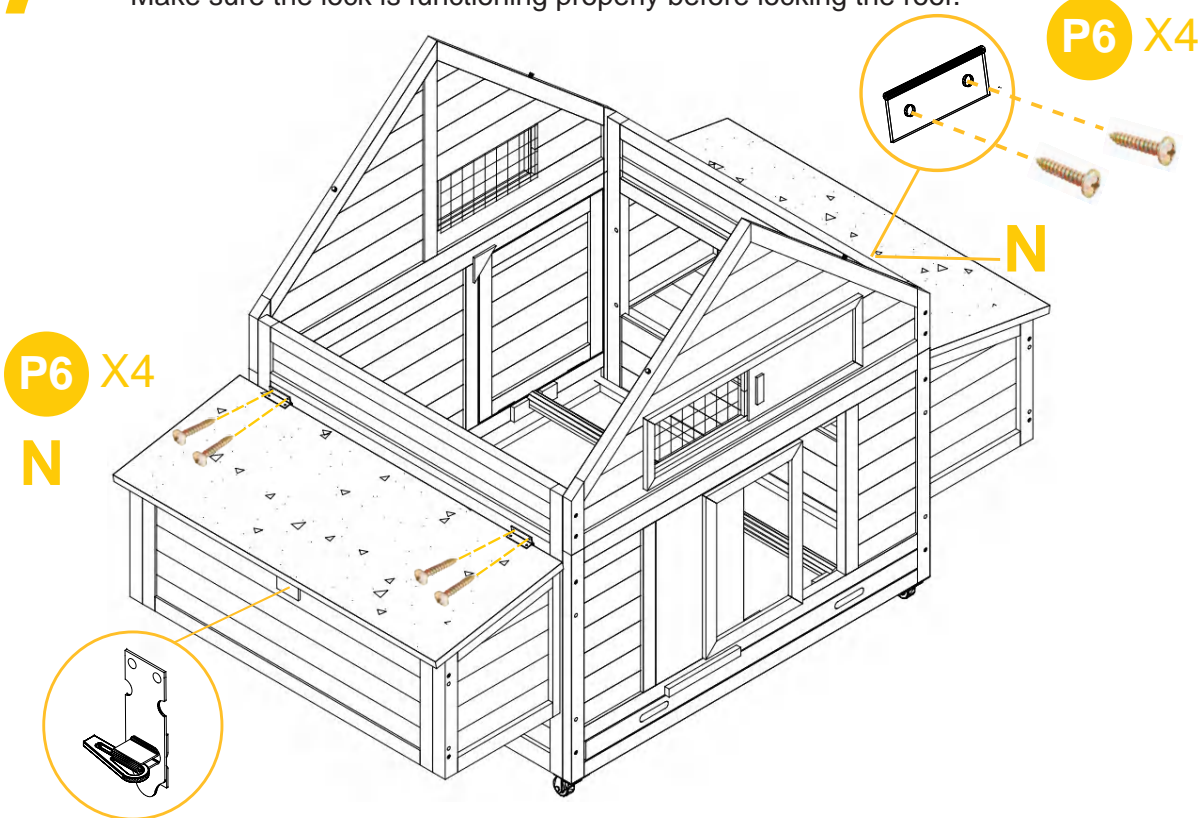

PRODUCT ASSEMBLY

08 Attach the coop roof 2xPart O to the coop by P4x8.

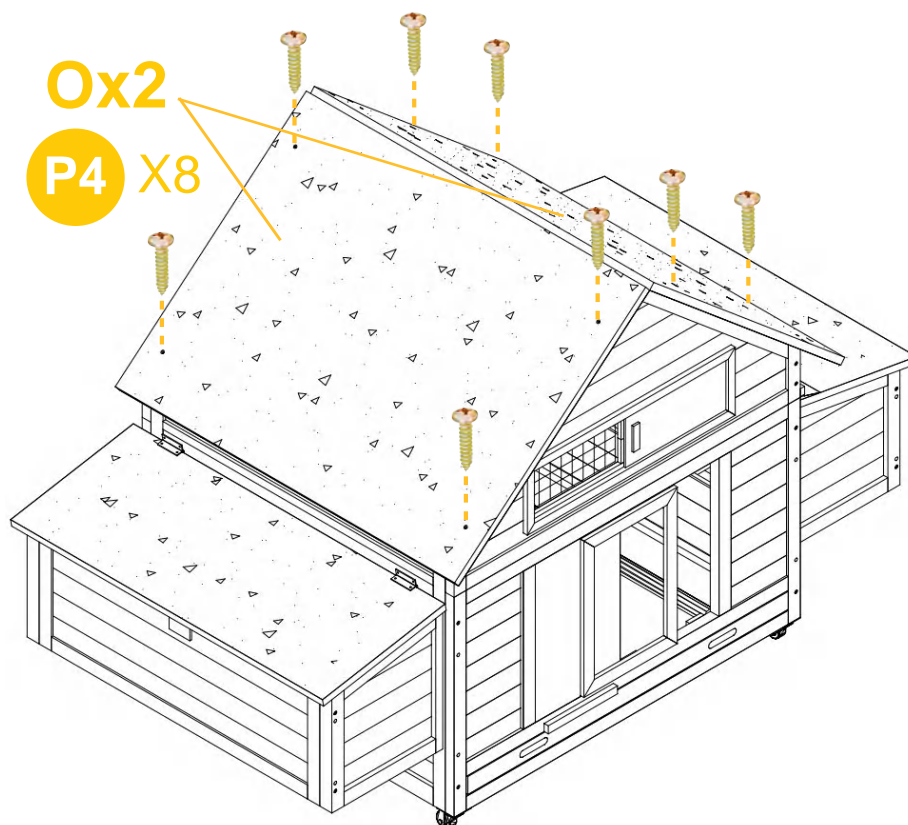

09 Attach the roof cap Part P by P5x4.

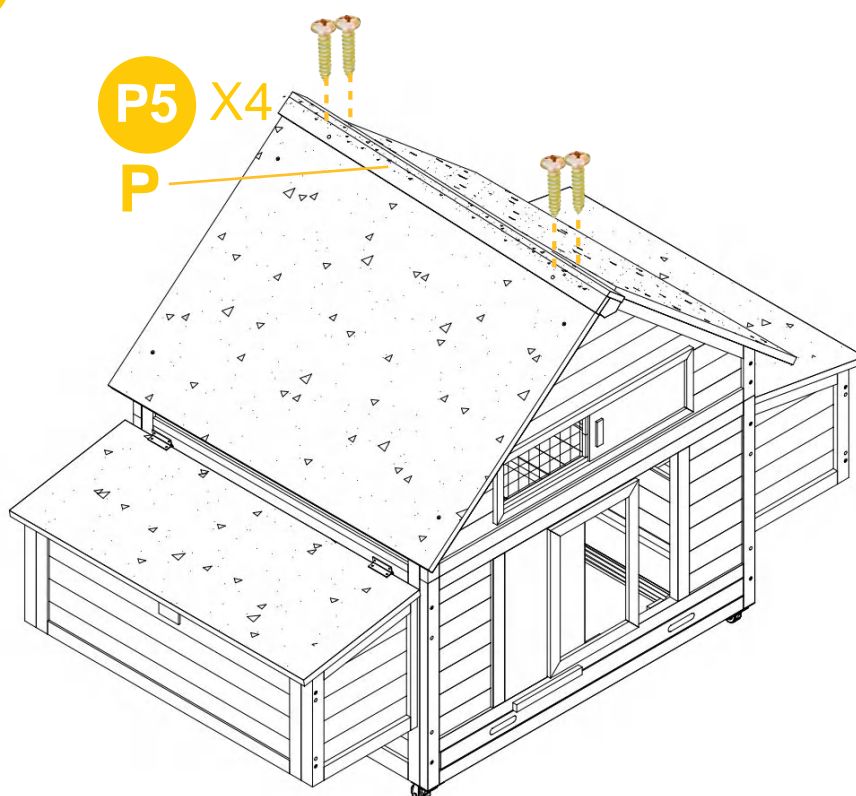

PRODUCT ASSEMBLY

10 Attach PVC Waterproof Strip 2xPart Q to the nesting box by P5x4 on each side.

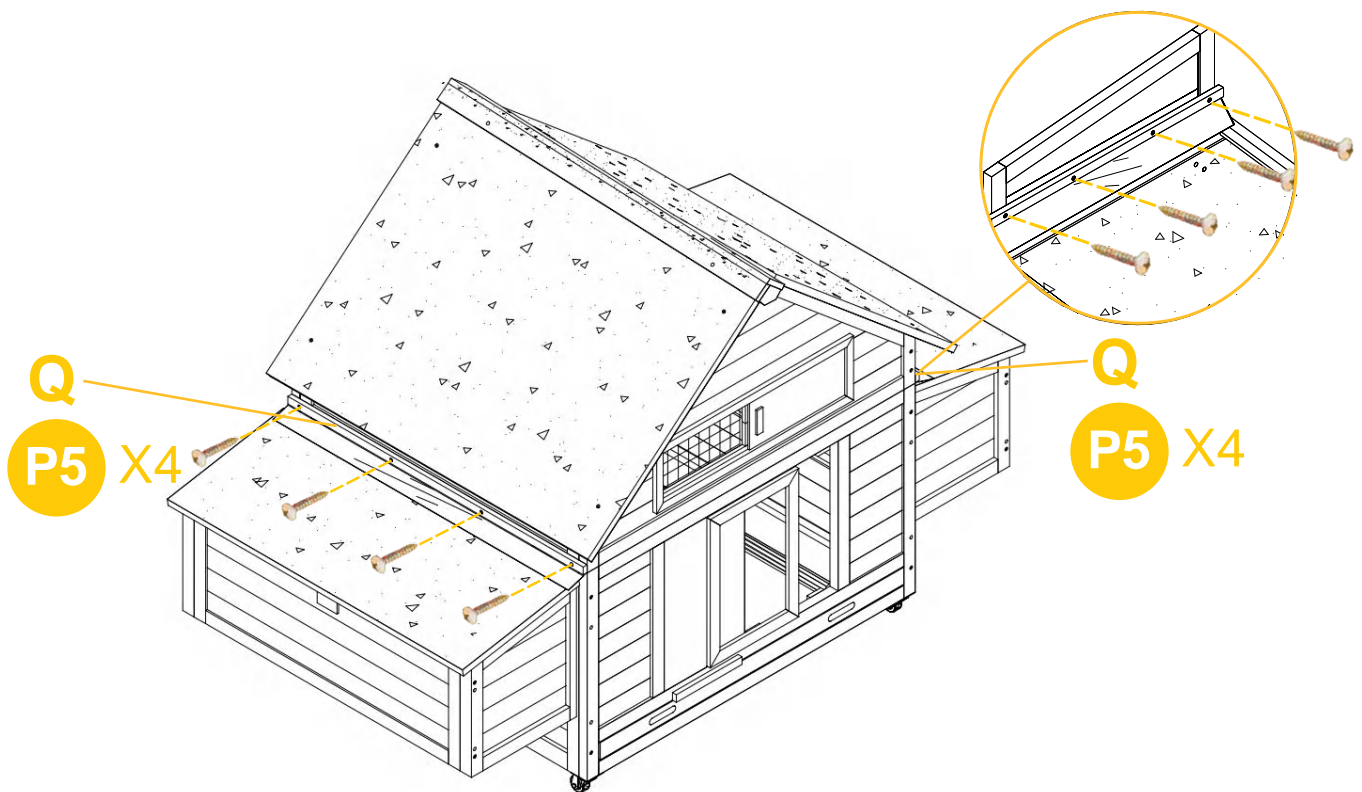

11 Attach the lock P7 to the tray by P6x6.

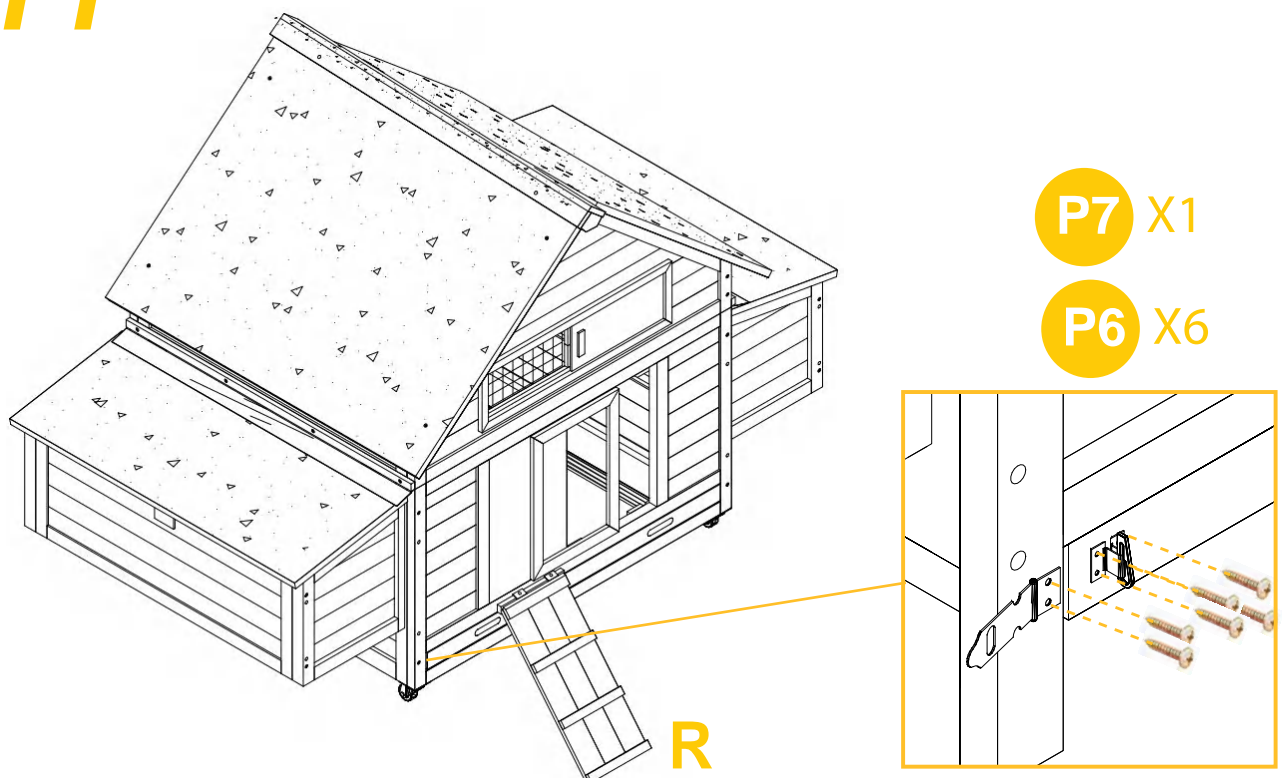

Notice

Read Before Assemble!

Pls ignore the following for only one coop owner !

Combination 1

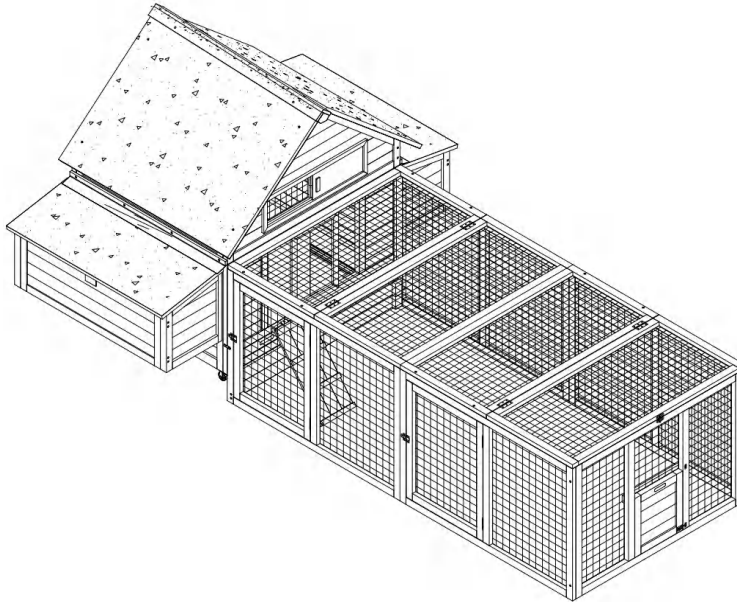

Combination 2

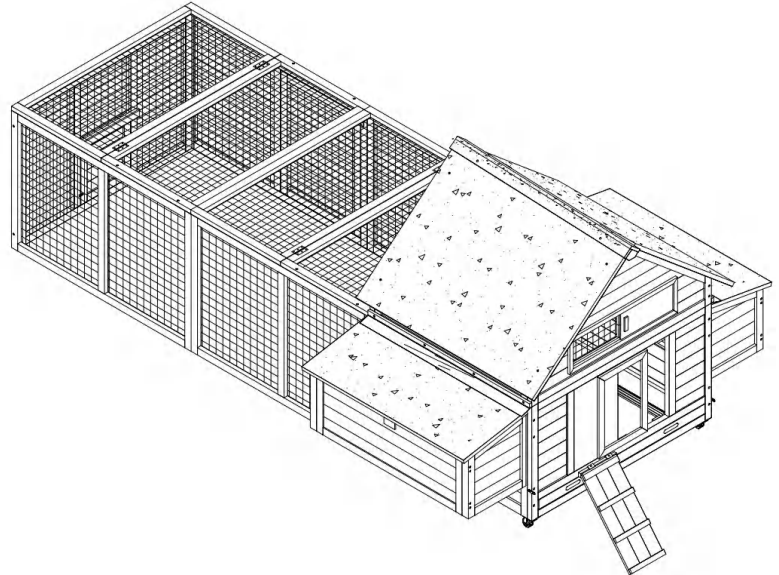

Combination 3

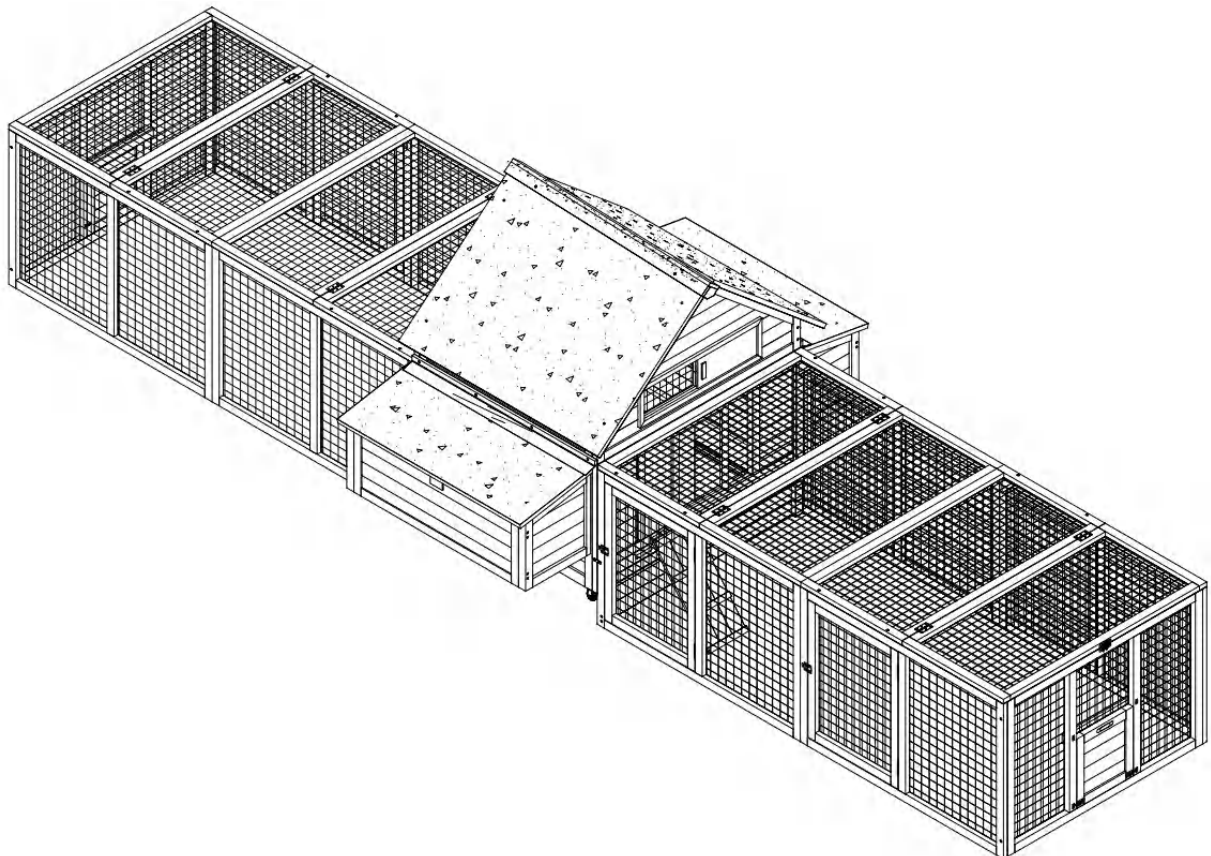

PRODUCT ASSEMBLY

12

Attach the bottom plate Part S to the run by P3x4.

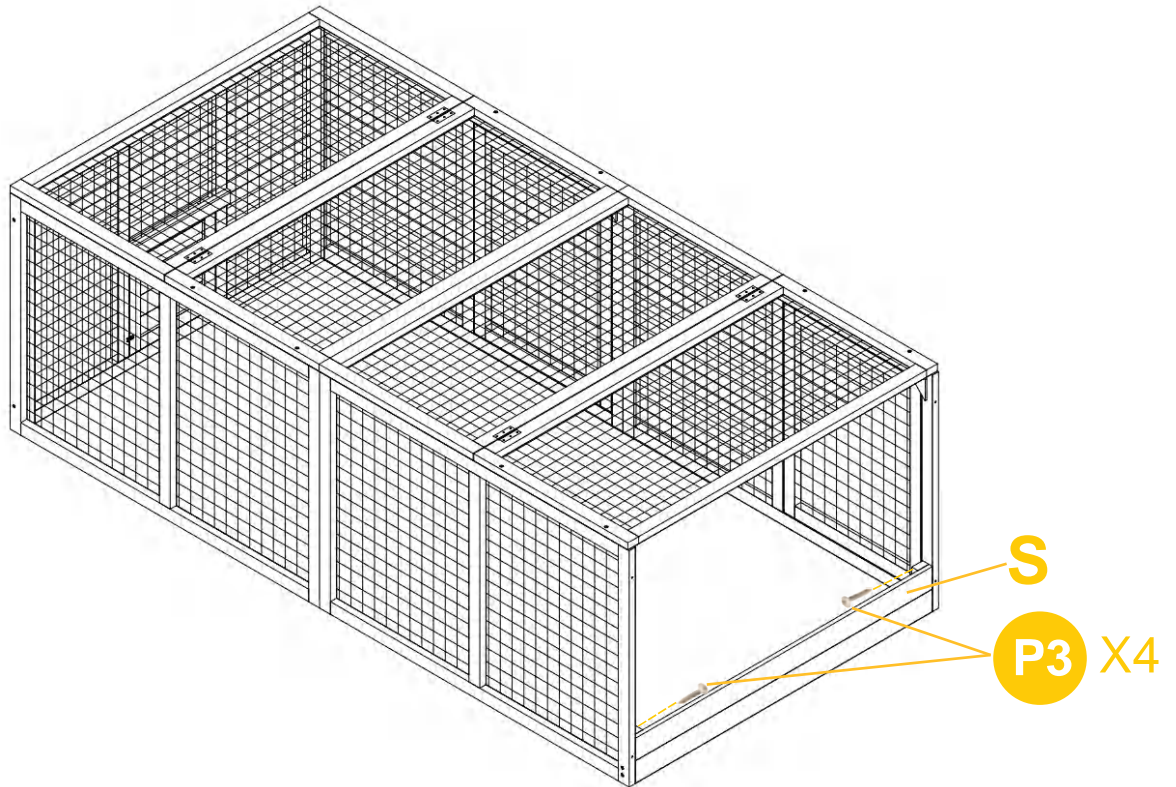

13

Attach the run to the coop by P2x1.

Connect the run to the coop using P9 by P6x2.

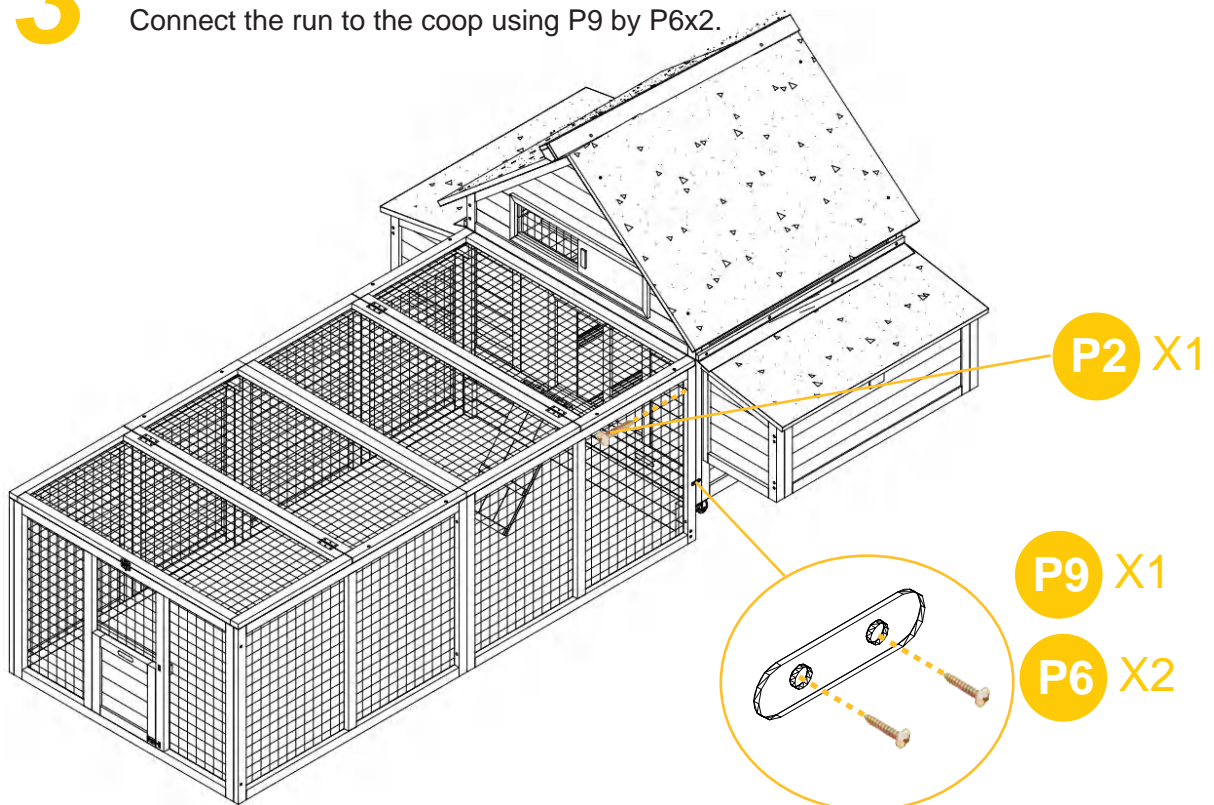

PRODUCT ASSEMBLY

14 Repeat on the other side(Please make sure the run door is open before screwing P2).

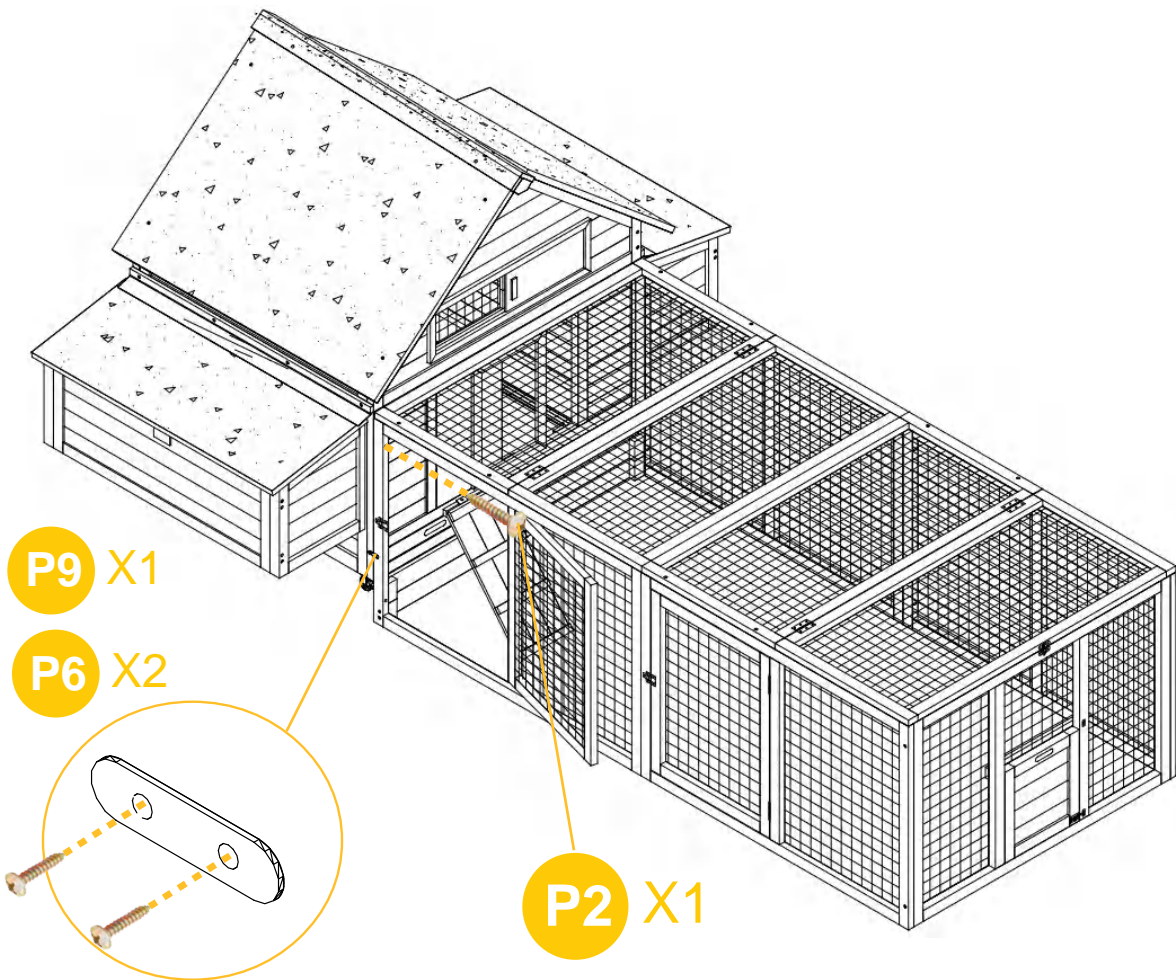

Finish



WARNING

Manufacturer and seller expressly disclaim any and all liability for personal injury, property damage or loss, whether direct, indirect, or incidental, resulting from the incorrect attachment, improper use, inadequate maintenance, or neglect of this