

INSTRUCTION MANUAL

AIR69

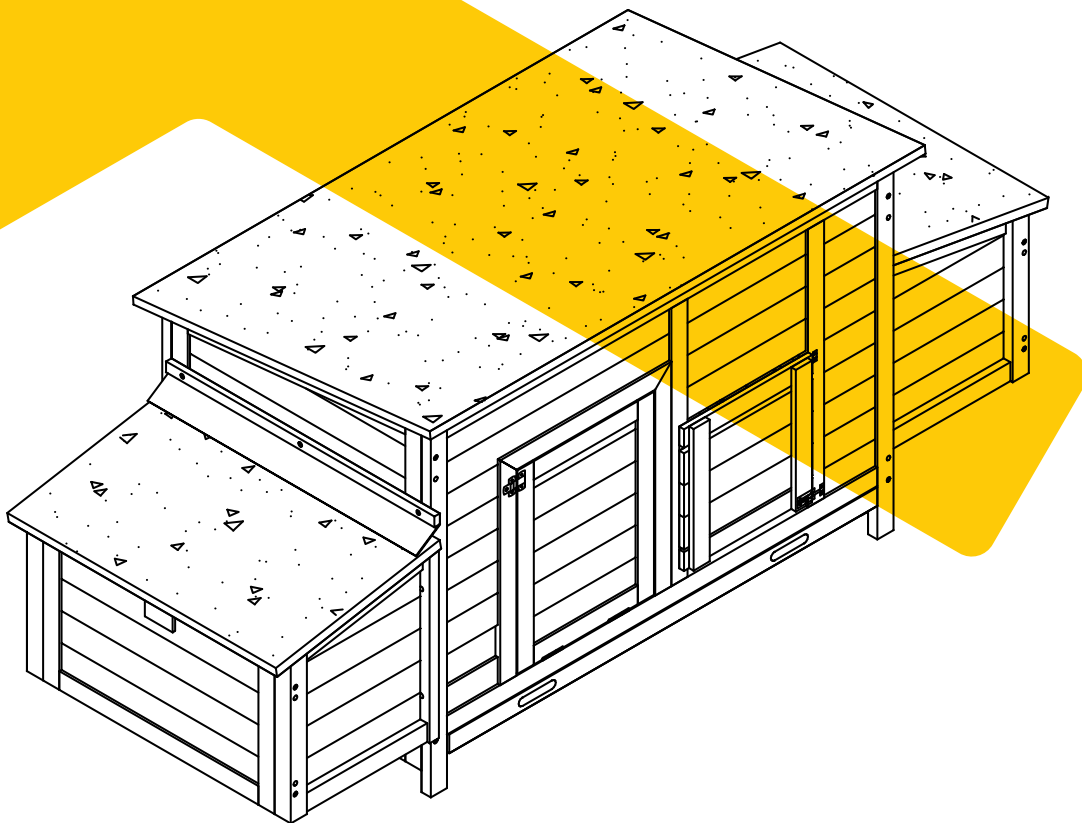



NOTICE

Please retain these instructions for future

- Firmly secure all bolts, screws and knobs before use.
- Reconfirm that all bolts, screws, and knobs are secure every 90 days.
- Fasten screws loosely during initial assembly. Do not fully tighten screws until the item is completely assembled.
- Do not use or store this item in the proximity of open flame or flammable/combustible chemicals.
- Be aware that some parts are heavy and have sharp edges.
- Be aware that moving parts can injure, crush and cut.
- If any parts are missing, broken, damaged, or worn, stop using this product until repairs are made and/or factory replacement parts are installed.
- Do not use this item in a way inconsistent with the manufacturer's instructions as this could void the product warranty.

TOOLS REQUIRED



PHILLIPS
SCREWDRIVER

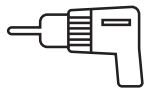

DRILL
(RECOMMENDED)



2PERSON
ASSEMBLY



APPROXIMATELY
60MIN. ASSEMBLY

HARDWARE

M6.0x50 mm BOLT
8PCS+1 spare



P1

M4.0x40 mm SCREW
16PCS+1 spare



P2

M3.5x60 mm SCREW
4PCS+1 spare



P3

M3.5x35 mm SCREW
6PCS+1 spare



P4

M3.5x25 mm SCREW
6PCS+1 spare

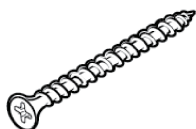

P5

M3.0x16 mm SCREW
28PCS+1 spare



P6

Lock
1PC

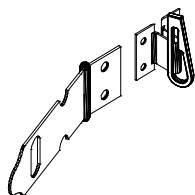

P7

Hinge
2PCS

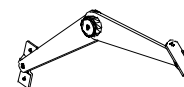

P8

PARTS

Front panel
1PC

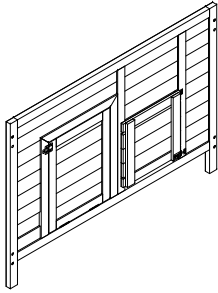

A

Back panel
1PC

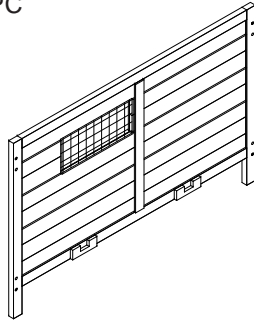

B

Left panel
1PC

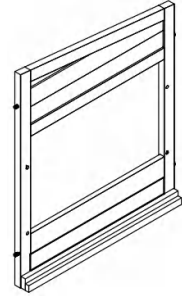

C

Right panel
1PC

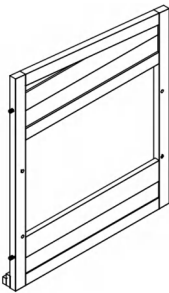

D

Tray
1PC

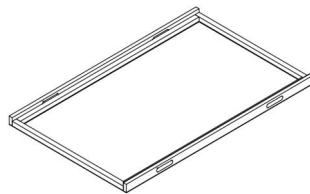

E

Perch
2PCS

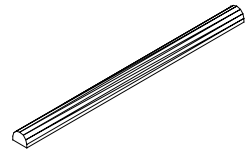

F

Left panel of nesting box
2PCS

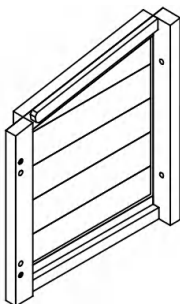

G1

Right panel of nesting box
2PCS

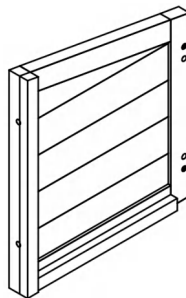

G2

Front panel of nesting box
2PCS

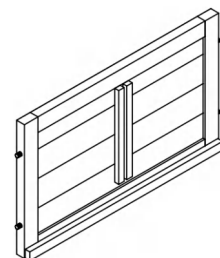

H

PARTS

Bottom of nesting box
2PCS

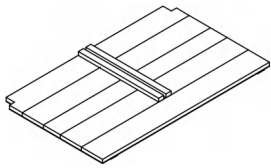

I

Divider of nesting box
2PCS

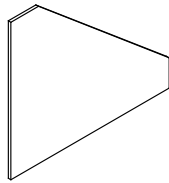

J

Roof of nesting box
2PCS

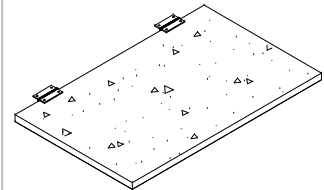

K

Roof of coop
1PC

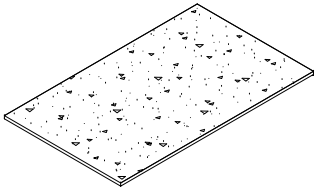

L

PVC Waterproof Strip
2PCS

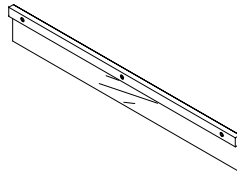

T

Hardware bag



PRODUCT ASSEMBLY

01 Attach the front & back panel Part A & B to the side panel Part C & D by 8xP2.

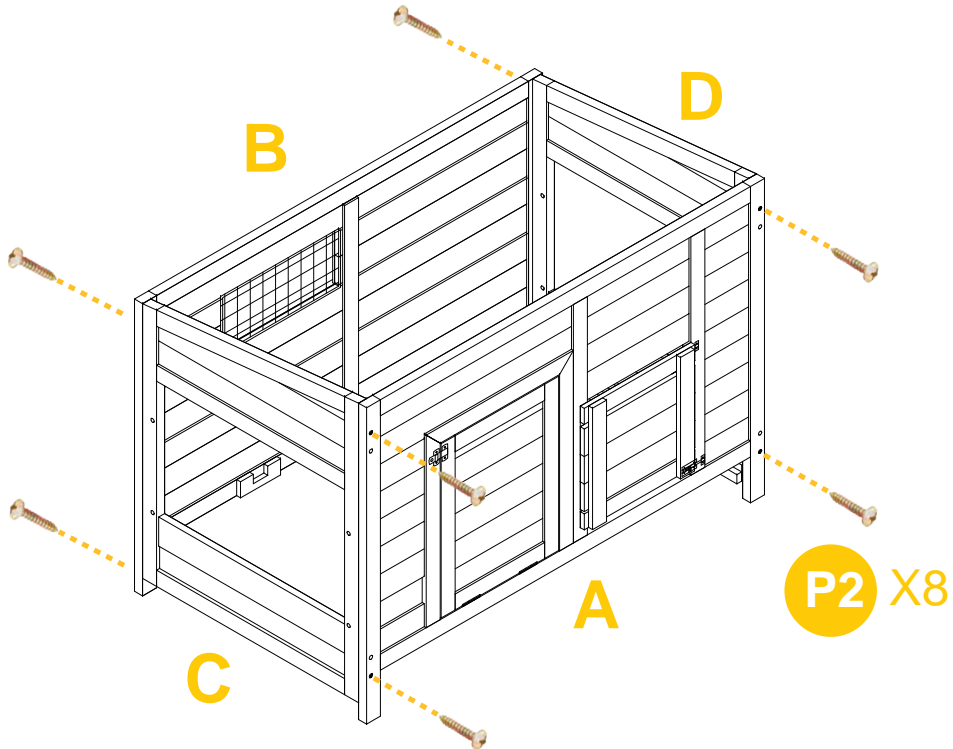

02 Slide in the metal tray Part E.
Insert the perch Part F into the slots inside the front and back panel.

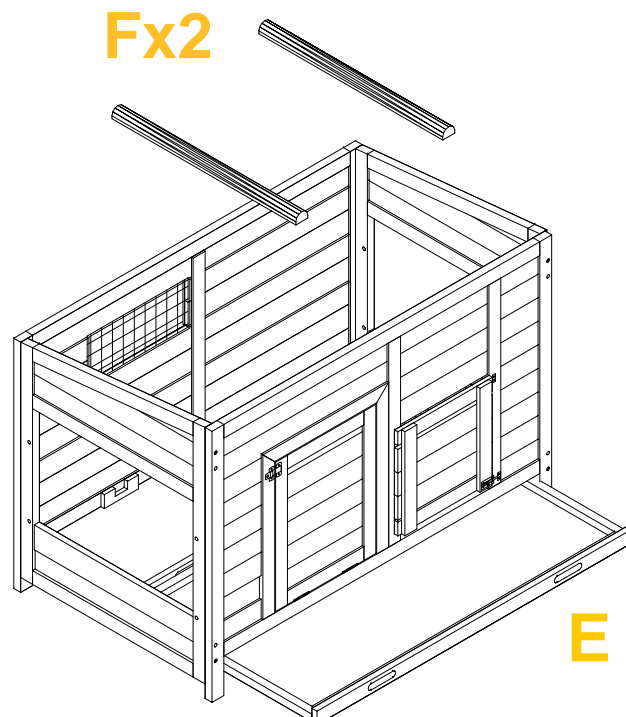

PRODUCT ASSEMBLY

03 Attach the side panels of nesting box Part G1 & G2 to the left side of coop by bolt 4xP1.

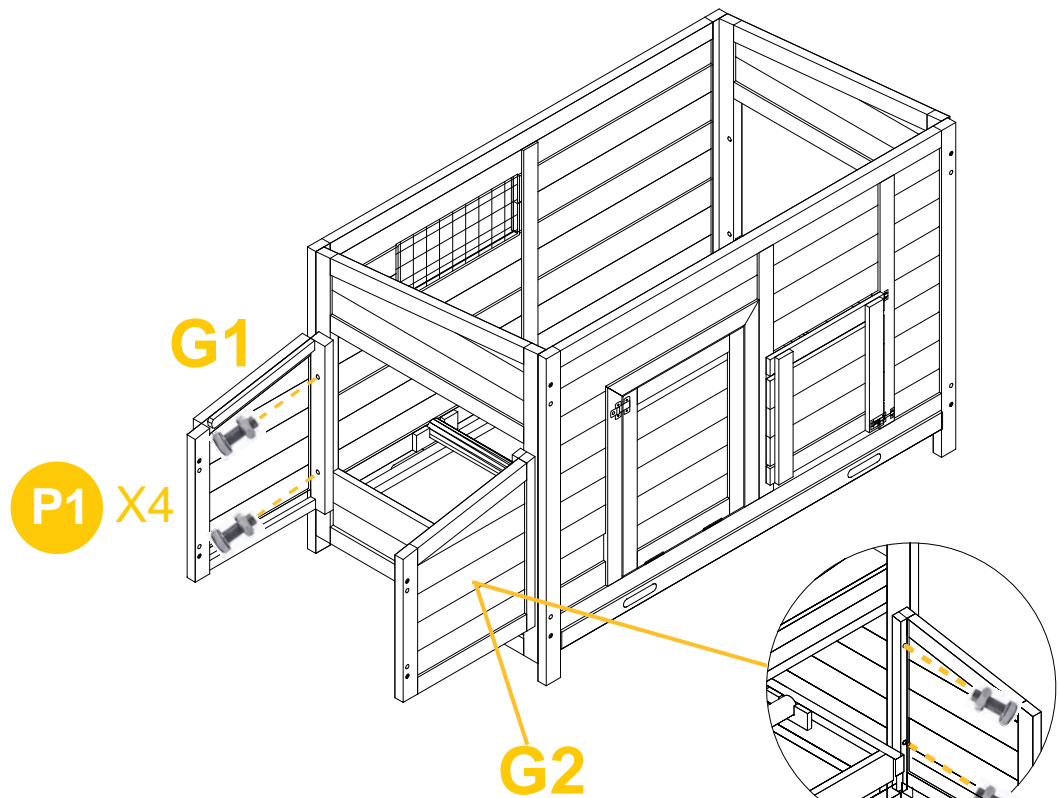

04 Attach the side panels of nesting box Part G1 & G2 to the right side of coop by bolt 4xP1.

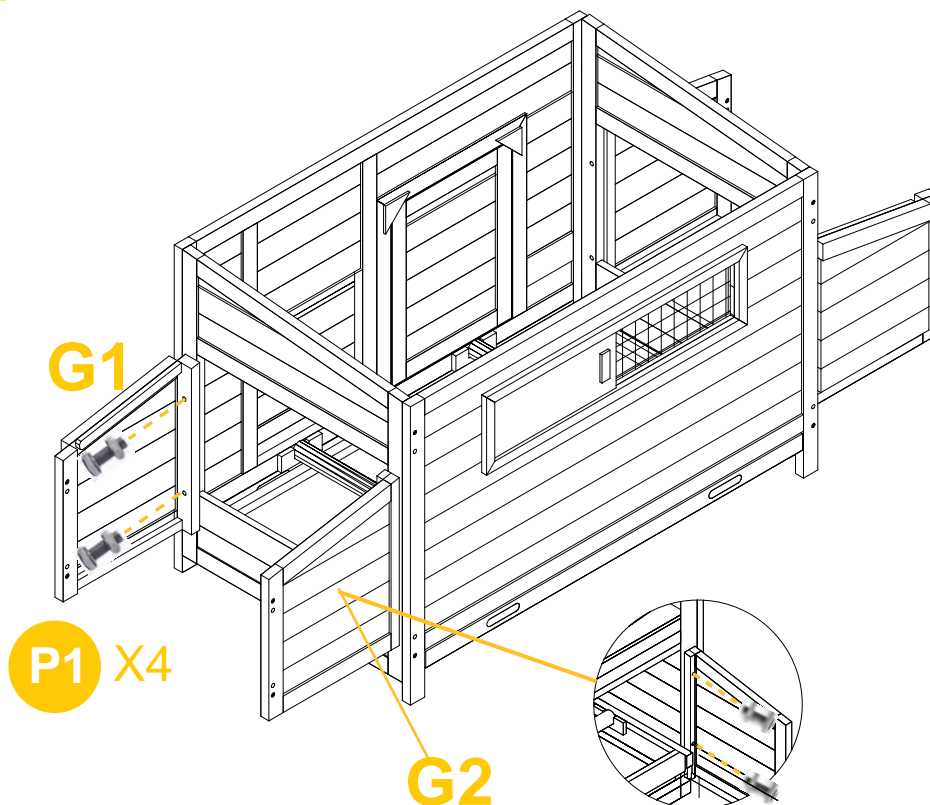

PRODUCT ASSEMBLY

- 05** Screw the side panel of nesting box to the front panel of nesting box Part H by 4xP2 each side.

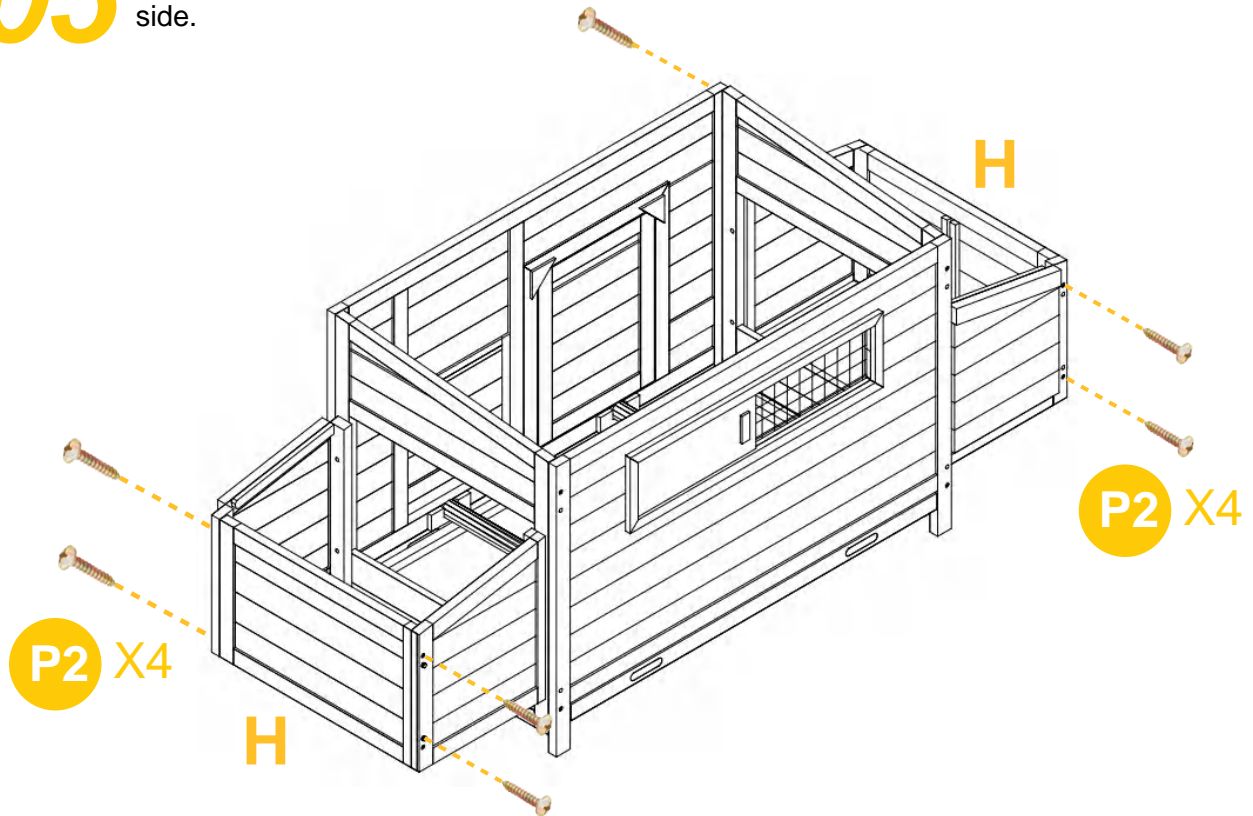

- 06** Drop in the bottom of nesting box Part I.
Slide in the divider Part J.

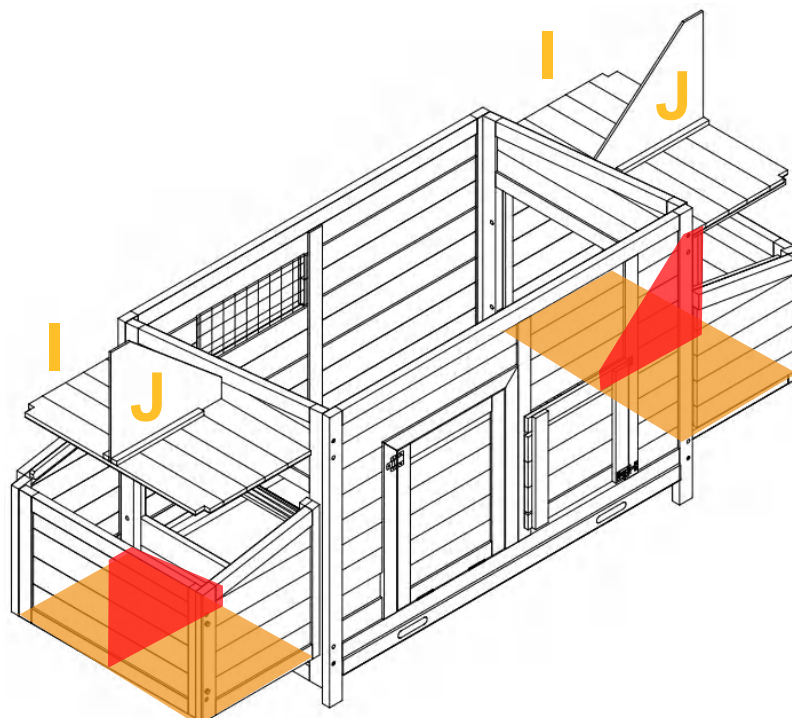

PRODUCT ASSEMBLY

07 Make sure the lock is functioning properly before locking the roof.
Attach the nesting box roof Part K to the nesting box by 4xP6 each side.

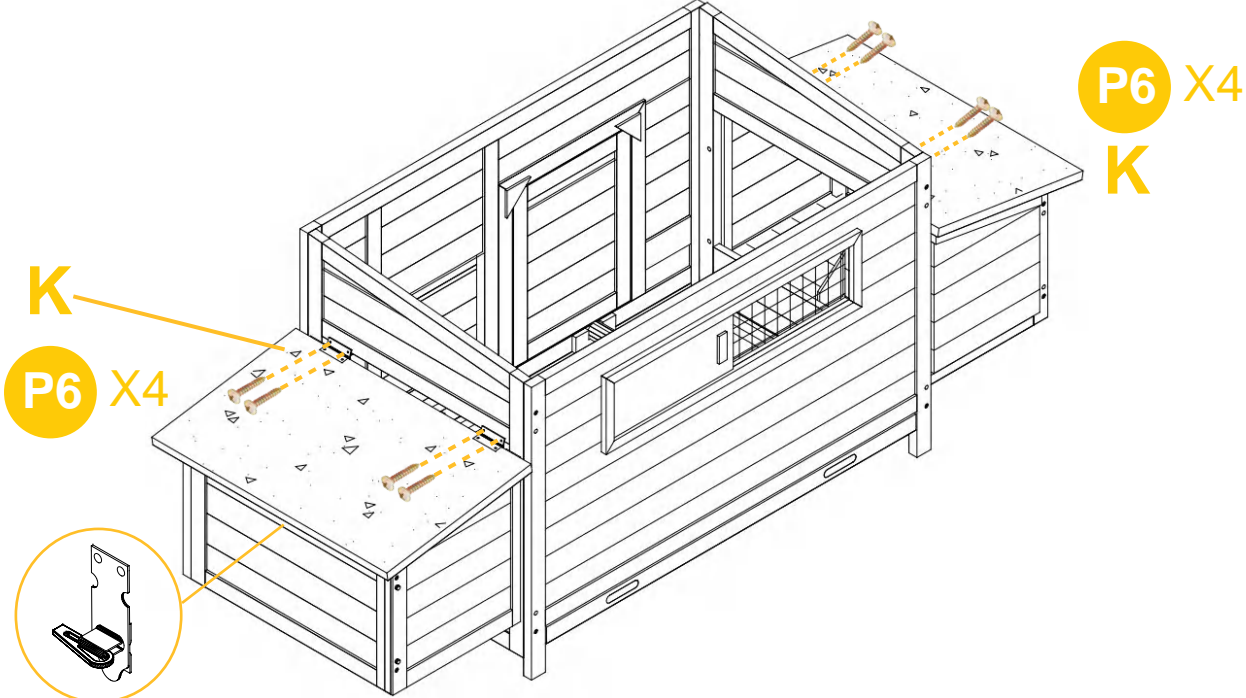

08 Attached PVC Waterproof Strip Part T to the nesting box by 3XP5 each.

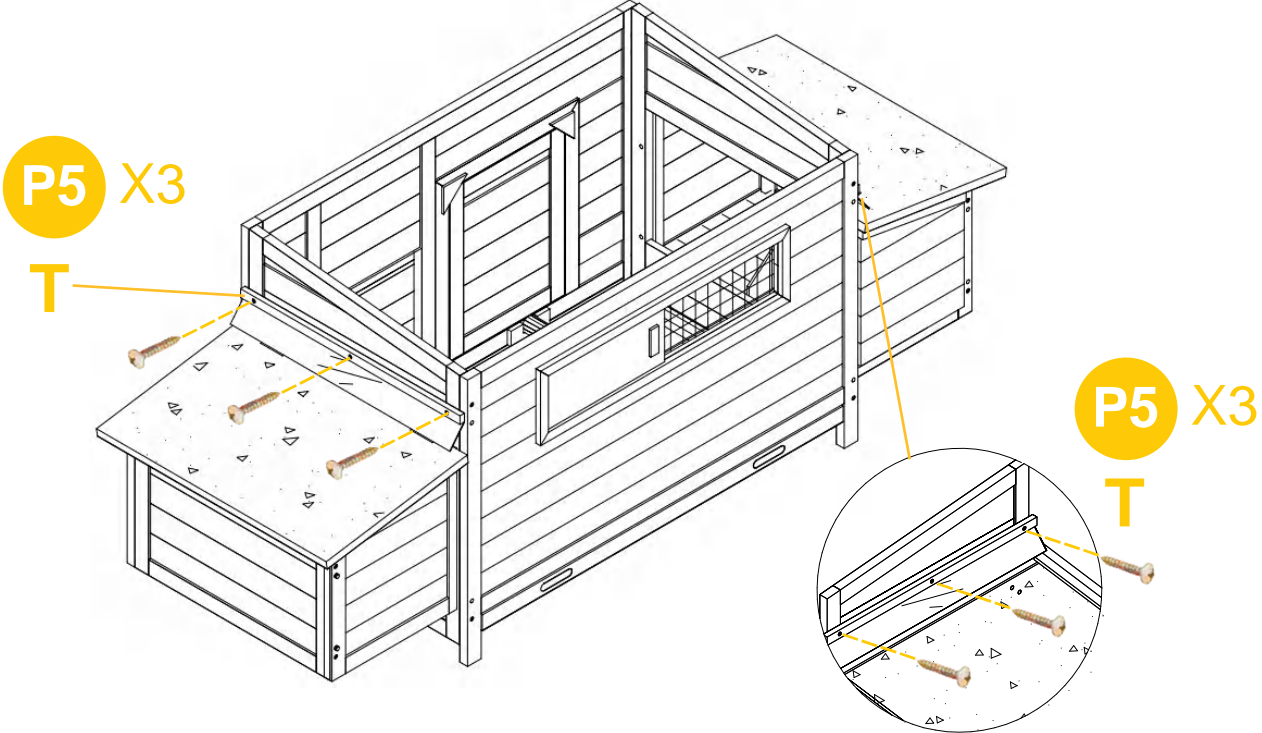

PRODUCT ASSEMBLY

09 Attach the coop roof Part L to the coop by 6xP6.

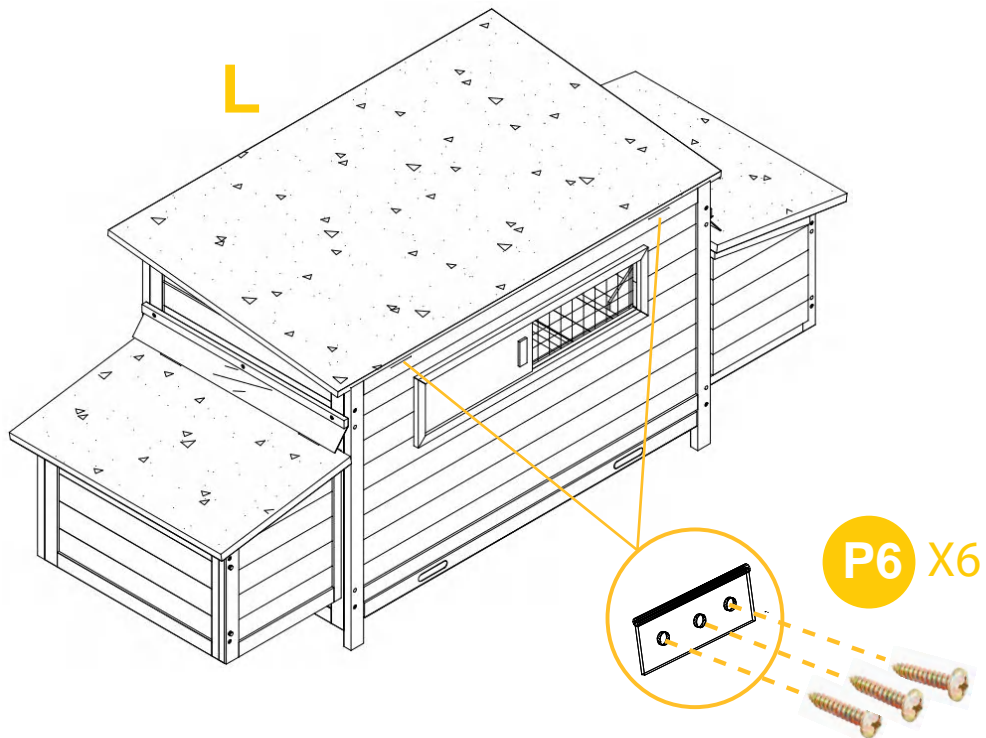

10 Attach the lock P7 to the tray by 6xP6.

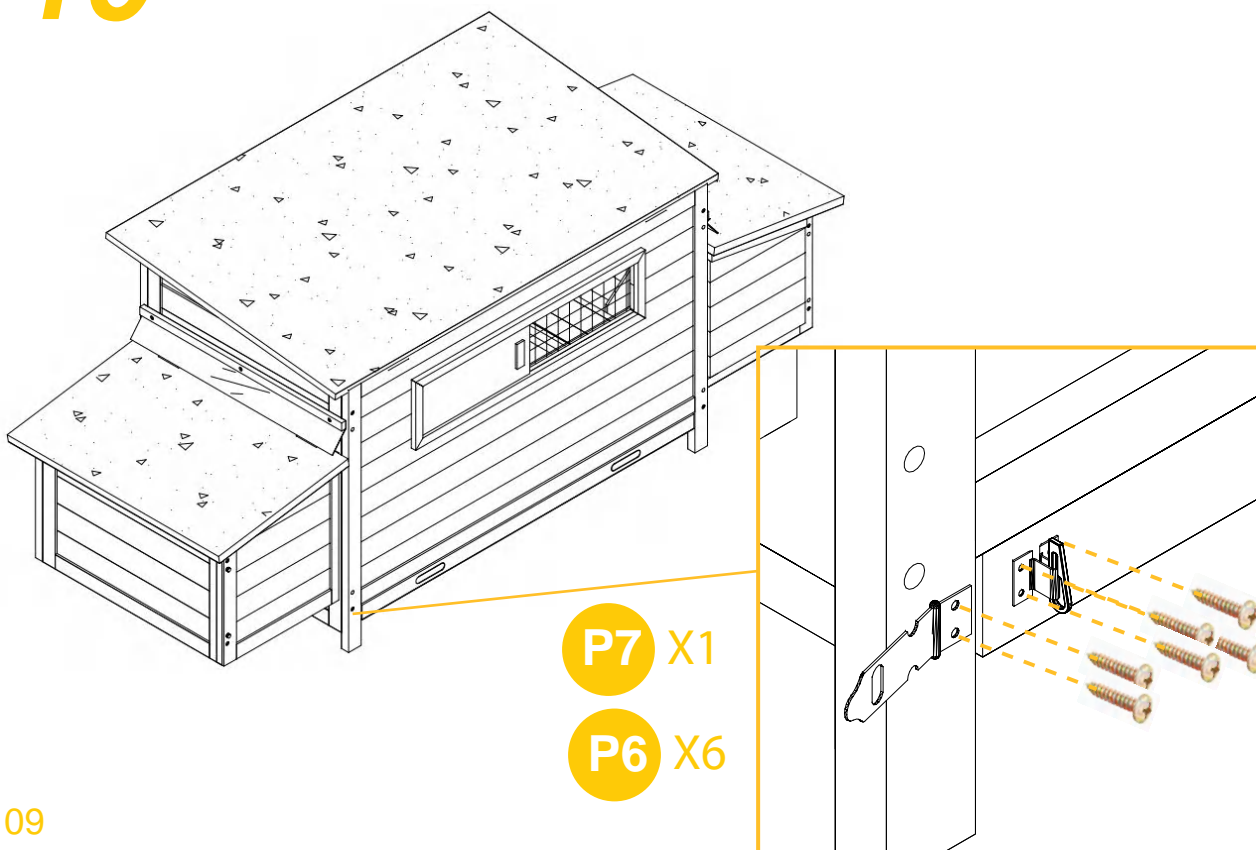

PRODUCT ASSEMBLY

11 Attach the roof hinge P8 to the coop by 4XP6 each side.

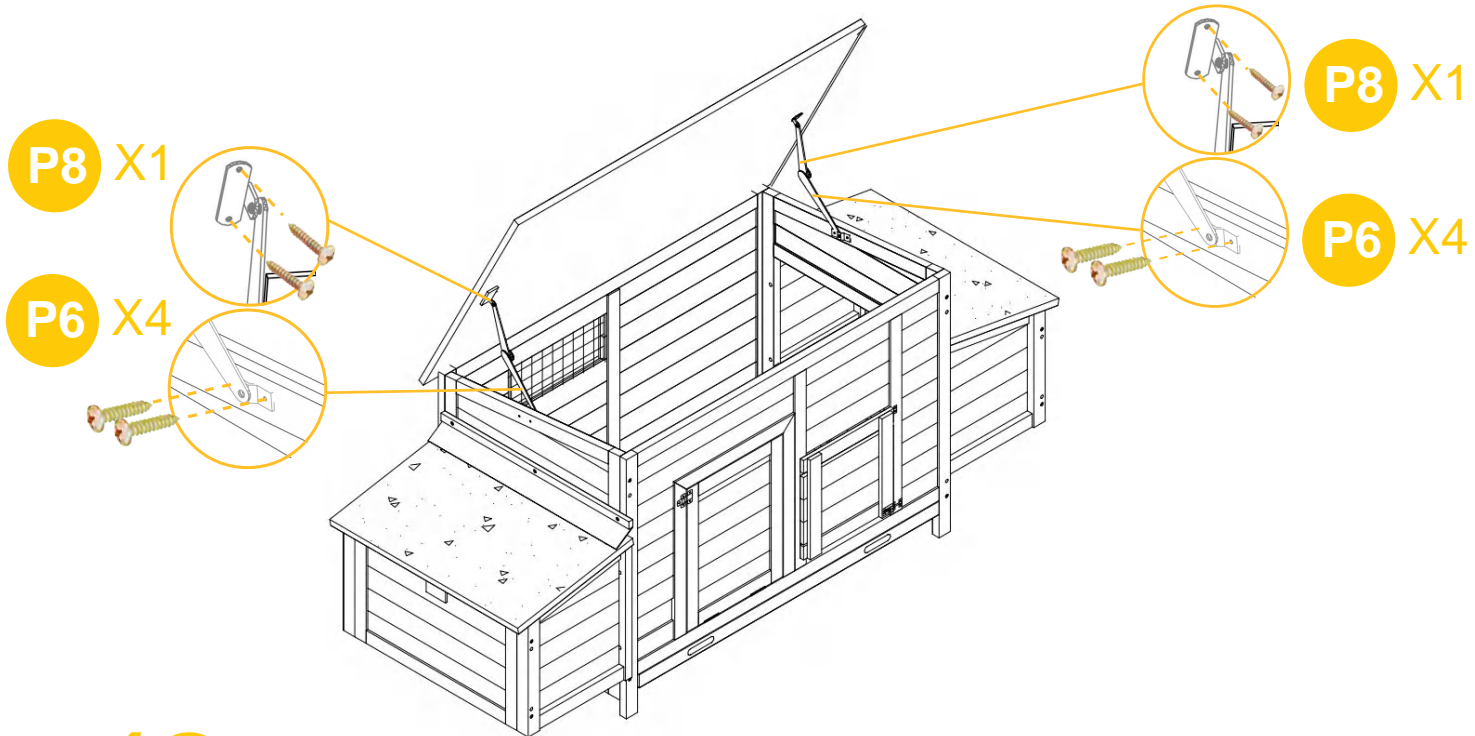

12 Pls ignore the following for only one coop owner !
Attach the run to the coop by 4XP3 screws.

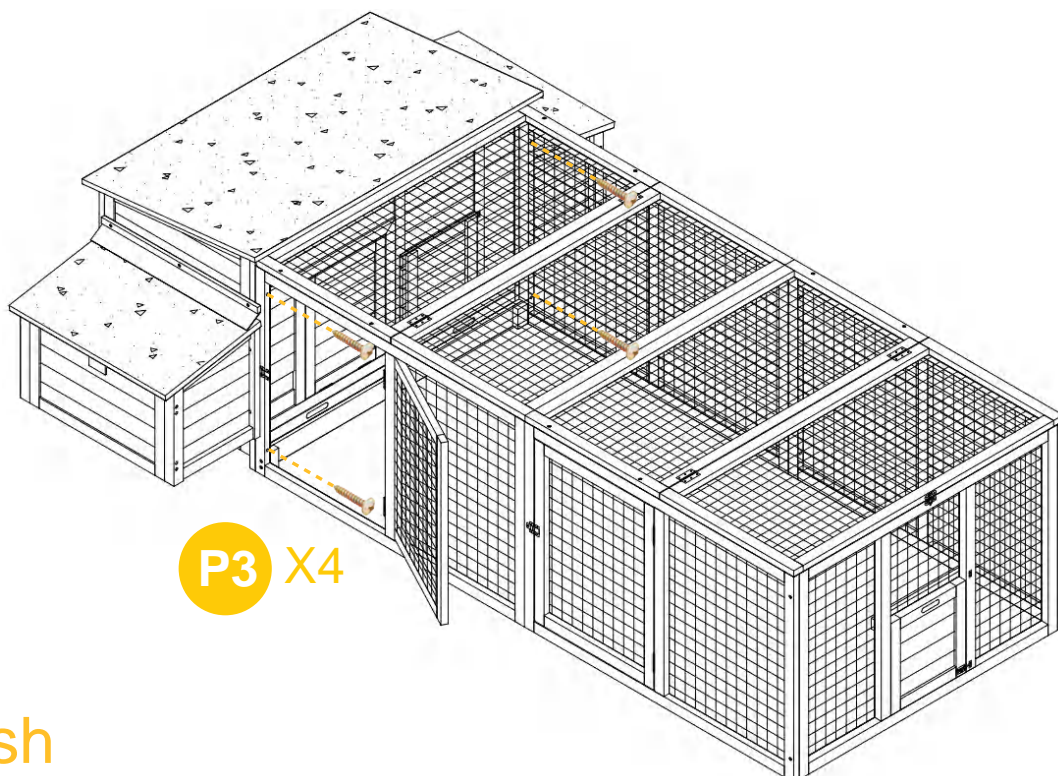

Finish



WARNING

Manufacturer and seller expressly disclaim any and all liability for personal injury, property damage or loss, whether direct, indirect, or incidental, resulting from the incorrect attachment, improper use, inadequate maintenance, or neglect of this